

ESP32-PICO-MINI-02

ESP32-PICO-MINI-02U

Datasheet

2.4 GHz Wi-Fi + Bluetooth® + Bluetooth LE module

Built around ESP32 series of SoCs, Xtensa® dual-core 32-bit LX6 microprocessor

Flash up to 8 MB, PSRAM up to 2 MB

27 GPIOs, rich set of peripherals

On-board PCB antenna or external antenna connector



ESP32-PICO-MINI-02



ESP32-PICO-MINI-02U



Version 1.0
Espressif Systems
Copyright © 2022

1 Module Overview

1.1 Features

CPU and On-Chip Memory

- ESP32-PICO-V3-02 embedded, Xtensa dual-core 32-bit LX6 microprocessor, up to 240 MHz
- 448 KB ROM for booting and core functions
- 520 KB SRAM for data and instructions
- 16 KB SRAM in RTC
- 8 MB SPI flash
- 2 MB PSRAM

Wi-Fi

- 802.11b/g/n
- Bit rate: 802.11n up to 150 Mbps
- A-MPDU and A-MSDU aggregation
- 0.4 μ s guard interval support
- Center frequency range of operating channel: 2412 ~ 2462 MHz

Bluetooth

- Bluetooth V4.2 BR/EDR and Bluetooth LE specification
- Class-1, class-2 and class-3 transmitter
- AFH
- CVSD and SBC

Peripherals

- SD card, UART, SPI, SDIO, I2C, LED PWM, Motor PWM, I2S, IR, pulse counter, GPIO, capacitive touch sensor, ADC, DAC, Two-Wire Automotive Interface (TWAI[®], compatible with ISO11898-1), Ethernet MAC

Integrated Components on Module

- 40 MHz crystal oscillator

Antenna Options

- ESP32-PICO-MINI-02: On-board PCB antenna
- ESP32-PICO-MINI-02U: external antenna via a connector

Operating Conditions

- Operating voltage/Power supply: 3.0 ~ 3.6 V
- Operating ambient temperature: -40 ~ 85 °C

Certification

- RF certification: CE/FCC/SRRC
- Green certification: REACH/RoHS

Test

- Reliability: HTOL/HTSL/uHAST/TCT/ESD

1.2 Description

ESP32-PICO-MINI-02 and ESP32-PICO-MINI-02U are two general-purpose Wi-Fi + Bluetooth + Bluetooth LE MCU modules. They are based on ESP32-PICO-V3-02, a System-in-Package (SiP) device, which integrates an 8 MB SPI flash, 2 MB SPI Pseudo static RAM (PSRAM) and 40 MHz crystal oscillator. The rich set of peripherals and a small size make the two modules an ideal choice for a wide variety of IoT applications, ranging from home automation, smart building, consumer electronics to industrial control, and they are suitable for intelligent speakers, speech recognition toys, intelligent gateway and Ethernet, etc.

ESP32-PICO-MINI-02 comes with a PCB antenna. ESP32-PICO-MINI-02U comes with a connector for an external antenna. The ordering information of the two modules is listed as follows:

Table 1: Ordering Information

Module	Ordering Code	Chip embedded	Module dimensions (mm)
ESP32-PICO-MINI-02	ESP32-PICO-MINI-02-N8R2	ESP32-PICO-V3-02	13.2 × 16.6 × 2.4
ESP32-PICO-MINI-02U	ESP32-PICO-MINI-02U-N8R2	ESP32-PICO-V3-02	13.2 × 11.2 × 2.4

At the core of ESP32-PICO-MINI-02 and ESP32-PICO-MINI-02U is the ESP32-PICO-V3-02 sip*. The chip embedded is designed to be scalable and adaptive. There are two CPU cores that can be individually controlled, and the CPU clock frequency is adjustable from 80 MHz to 240 MHz. The chip also has a low-power coprocessor that can be used instead of the CPU to save power while performing tasks that do not require much computing power, such as monitoring of peripherals. This ESP32 chip integrates a rich set of peripherals, ranging from SD card interface, capacitive touch sensors, ADC, DAC, Two-Wire Automotive Interface, to Ethernet, high-speed SPI, UART, I2S, I2C, etc.

Note:

* For details on the part numbers of the ESP32 family of chips, please refer to the document [ESP32 Series Datasheet](#).

Contents

1	Module Overview	2
1.1	Features	2
1.2	Description	2
2	Block Diagram	8
3	Pin Definitions	9
3.1	Pin Layout	9
3.2	Pin Description	10
3.3	Strapping Pins	11
4	Electrical Characteristics	13
4.1	Absolute Maximum Ratings	13
4.2	Recommended Operating Conditions	13
4.3	DC Characteristics (3.3 V, 25 °C)	13
4.4	Current Consumption Characteristics	14
4.5	Wi-Fi RF Characteristics	15
4.5.1	Wi-Fi RF Standards	15
4.5.2	Transmitter Characteristics	15
4.5.3	Receiver Characteristics	16
4.6	Bluetooth Radio	17
4.6.1	Receiver – Basic Data Rate	17
4.6.2	Transmitter – Basic Data Rate	18
4.6.3	Receiver – Enhanced Data Rate	18
4.6.4	Transmitter – Enhanced Data Rate	19
4.7	Bluetooth LE Radio	19
4.7.1	Receiver	19
4.7.2	Transmitter	20
5	Module Schematics	21
6	Peripheral Schematics	23
7	Physical Dimensions and PCB Land Pattern	24
7.1	Physical Dimensions	24
7.2	Recommended PCB Land Pattern	25
7.3	Dimensions of External Antenna Connector	26
8	Product Handling	28
8.1	Storage Conditions	28
8.2	Electrostatic Discharge (ESD)	28
8.3	Reflow Profile	28

9 U.S. FCC Statement	29
10 Related Documentation and Resources	32
Revision History	33

List of Tables

1	Ordering Information	3
2	Pin Definitions	10
3	Strapping Pins	12
4	Absolute Maximum Ratings	13
5	Recommended Operating Conditions	13
6	DC Characteristics (3.3 V, 25 °C)	13
7	Current Consumption Depending on RF Modes	14
8	Current Consumption Depending on Work Modes	15
9	Wi-Fi RF Standards	15
10	TX Power Characteristics	16
11	RX Sensitivity Characteristics	16
12	RX Maximum Input Level	17
13	Adjacent Channel Rejection	17
14	Receiver Characteristics – Basic Data Rate	17
15	Transmitter Characteristics – Basic Data Rate	18
16	Receiver Characteristics – Enhanced Data Rate	18
17	Transmitter Characteristics – Enhanced Data Rate	19
18	Receiver Characteristics – BLE	20
19	Transmitter Characteristics – BLE	20

List of Figures

1	ESP32-PICO-MINI-02 Block Diagram	8
2	ESP32-PICO-MINI-02U Block Diagram	8
3	ESP32-PICO-MINI-02 Pin Layout (Top View)	9
4	ESP32-PICO-MINI-02U Pin Layout (Top View)	10
5	ESP32-PICO-MINI-02 Schematics	21
6	ESP32-PICO-MINI-02U Schematics	22
7	Peripheral Schematics	23
8	ESP32-PICO-MINI-02 Physical Dimensions	24
9	ESP32-PICO-MINI-02U Physical Dimensions	24
10	ESP32-PICO-MINI-02 Recommended PCB Land Pattern	25
11	ESP32-PICO-MINI-02U Recommended PCB Land Pattern	26
12	Dimensions of External Antenna Connector	27
13	Reflow Profile	28

2 Block Diagram

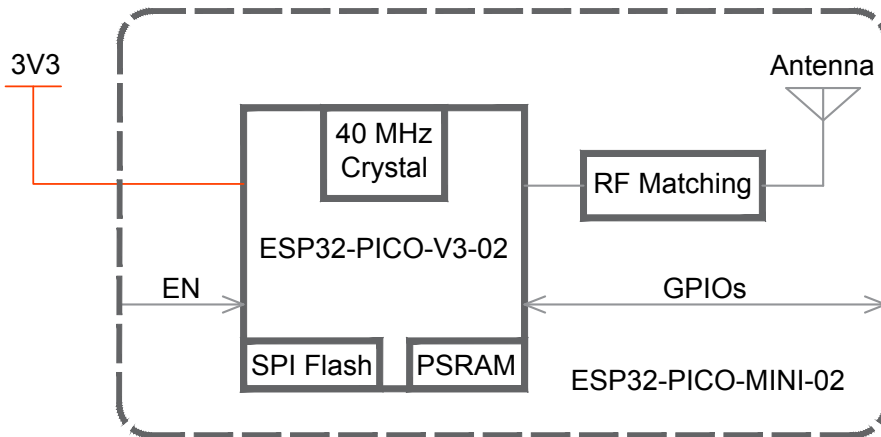

Figure 1: ESP32-PICO-MINI-02 Block Diagram

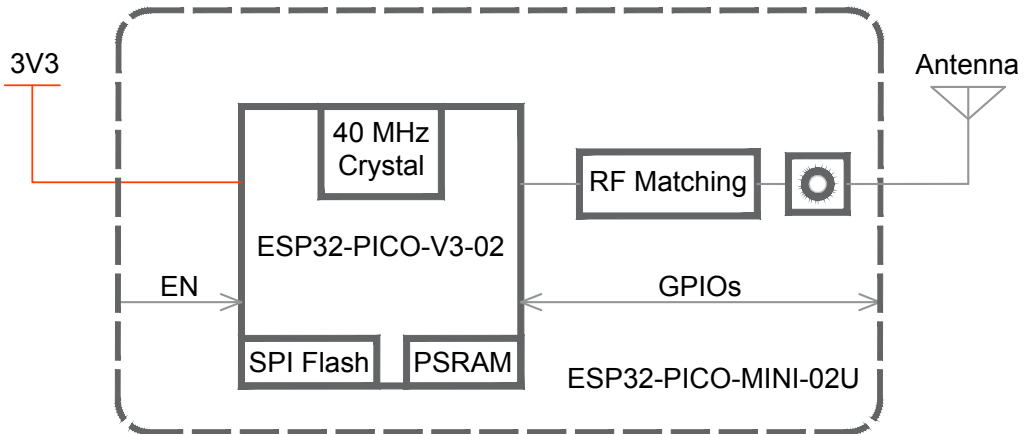

Figure 2: ESP32-PICO-MINI-02U Block Diagram

3 Pin Definitions

3.1 Pin Layout

The pin diagram below shows the approximate location of pins on the module. For the actual diagram drawn to scale, please refer to Figure 7.1 *Physical Dimensions*.

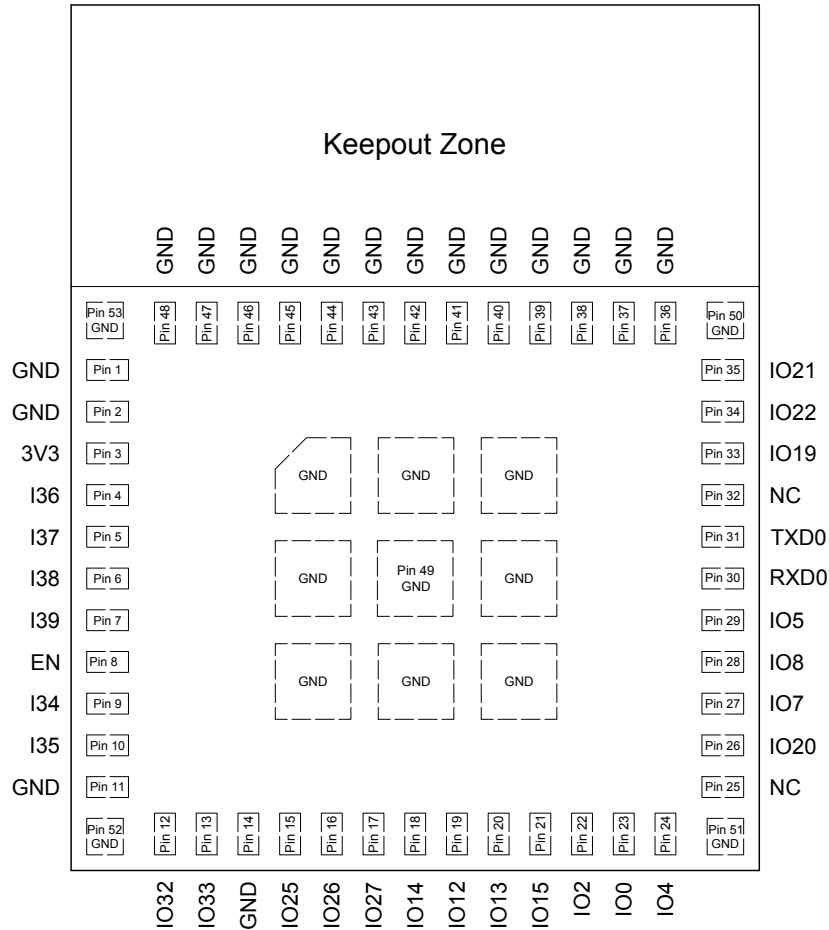

Figure 3: ESP32-PICO-MINI-02 Pin Layout (Top View)

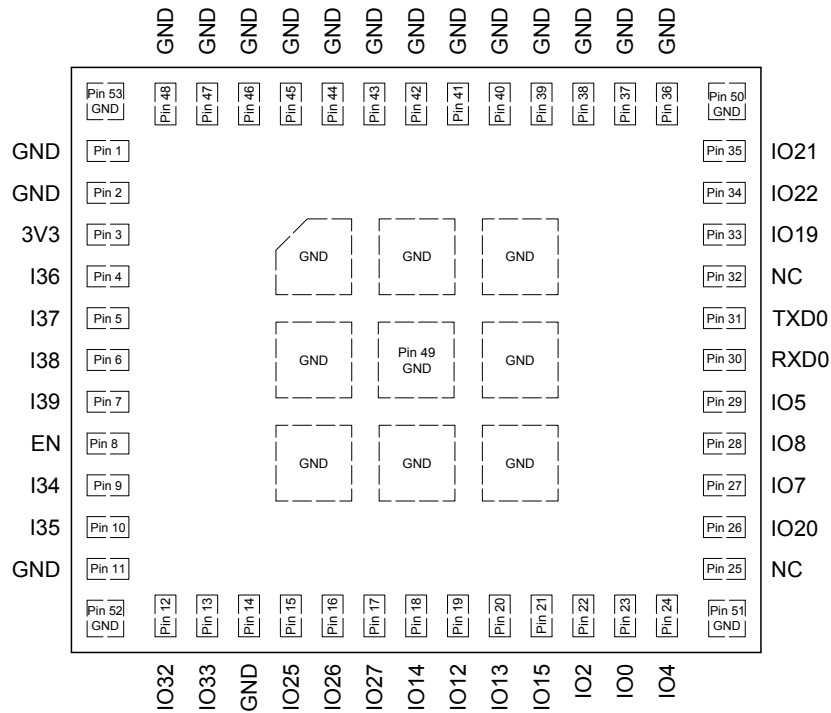

Figure 4: ESP32-PICO-MINI-02U Pin Layout (Top View)

3.2 Pin Description

ESP32-PICO-MINI-02 and ESP32-PICO-MINI-02U each has 53 pins. See pin definitions in Table 2.

For peripheral pin configurations, please refer to [ESP32 Series Datasheet](#).

Table 2: Pin Definitions

Name	No.	Type ¹	Function
GND	1, 2, 11, 14, 36-53	P	Ground
3V3	3	P	Power supply
I36	4	I	GPIO36, ADC1_CH0, RTC_GPIO0
I37	5	I	GPIO37, ADC1_CH1, RTC_GPIO1
I38	6	I	GPIO38, ADC1_CH2, RTC_GPIO2
I39	7	I	GPIO39, ADC1_CH3, RTC_GPIO3
EN	8	I	High: On; enables the chip Low: Off; the chip powers off Note: Do not leave EN pin floating.
I34	9	I	GPIO34, ADC1_CH6, RTC_GPIO4
I35	10	I	GPIO35, ADC1_CH7, RTC_GPIO5
IO32	12	I/O	GPIO32, XTAL_32K_P (32.768 kHz crystal oscillator input), ADC1_CH4, TOUCH9, RTC_GPIO9
IO33	13	I/O	GPIO33, XTAL_32K_N (32.768 kHz crystal oscillator output), ADC1_CH5, TOUCH8, RTC_GPIO8
IO25	15	I/O	GPIO25, DAC_1, ADC2_CH8, RTC_GPIO6, EMAC_RXD0
IO26	16	I/O	GPIO26, DAC_2, ADC2_CH9, RTC_GPIO7, EMAC_RXD1

Cont'd on next page

Table 2 – cont'd from previous page

Name	No.	Type ¹	Function
IO27	17	I/O	GPIO27, ADC2_CH7, TOUCH7, RTC_GPIO17, EMAC_RX_DV
IO14	18	I/O	GPIO14, ADC2_CH6, TOUCH6, RTC_GPIO16, MTMS, HSPICLK, HS2_CLK, SD_CLK, EMAC_TXD2
IO12	19	I/O	GPIO12, ADC2_CH5, TOUCH5, RTC_GPIO15, MTDI, HSPIQ, HS2_DATA2, SD_DATA2, EMAC_TXD3
IO13	20	I/O	GPIO13, ADC2_CH4, TOUCH4, RTC_GPIO14, MTCK, HSPID, HS2_DATA3, SD_DATA3, EMAC_RX_ER
IO15	21	I/O	GPIO15, ADC2_CH3, TOUCH3, RTC_GPIO13, MTDO, HSPICS0, HS2_CMD, SD_CMD, EMAC_RXD3
IO2	22	I/O	GPIO2, ADC2_CH2, TOUCH2, RTC_GPIO12, HSPiWP, HS2_DATA0, SD_DATA0
IO0	23	I/O	GPIO0, ADC2_CH1, TOUCH1, RTC_GPIO11, CLK_OUT1, EMAC_TX_CLK
IO4	24	I/O	GPIO4, ADC2_CH0, TOUCH0, RTC_GPIO10, HSPiHD, HS2_DATA1, SD_DATA1, EMAC_TX_ER
NC	25	-	-
IO20	26	I/O	GPIO20
IO7	27	I/O	GPIO7, HS1_DATA0, U2RTS, SD_DATA0
IO8	28	I/O	GPIO8, HS1_DATA1, U2CTS, SD_DATA1
IO5	29	I/O	GPIO5, VSPICS0, HS1_DATA6, EMAC_RX_CLK
RXD0	30	I/O	GPIO3, U0RXD, CLK_OUT2
TXD0	31	I/O	GPIO1, U0TXD, CLK_OUT3, EMAC_RXD2
NC	32	-	-
IO19	33	I/O	GPIO19, VSPIQ, U0CTS, EMAC_TXD0
IO22	34	I/O	GPIO22, VSPIWP, U0RTS, EMAC_TXD1
IO21	35	I/O	GPIO21, VSPIHD, EMAC_TX_EN

* P: power supply; I: input; O: output.

* Pins CMD/IO11 and CLK/IO6 are used for connecting the embedded flash, and pins SD2/IO9 and SD3/IO10 are used for connecting embedded PSRAM. These pins are not led out.

3.3 Strapping Pins

Note:

The content below is excerpted from Section Strapping Pins in [ESP32 Series Datasheet](#). For the strapping pin mapping between the chip and modules, please refer to Chapter 5 [Module Schematics](#).

ESP32-PICO-V3-02 has five strapping pins:

- MTDI
- GPIO0
- GPIO2
- MTDO

- GPIO5

Software can read the values of these five bits from register "GPIO_STRAPPING".

During the chip's system reset release (power-on-reset, RTC watchdog reset and brownout reset), the latches of the strapping pins sample the voltage level as strapping bits of "0" or "1", and hold these bits until the chip is powered down or shut down. The strapping bits configure the device's boot mode, the operating voltage of VDD_SDIO and other initial system settings.

Each strapping pin is connected to its internal pull-up/pull-down during the chip reset. Consequently, if a strapping pin is unconnected or the connected external circuit is high-impedance, the internal weak pull-up/pull-down will determine the default input level of the strapping pins.

To change the strapping bit values, users can apply the external pull-down/pull-up resistances, or use the host MCU's GPIOs to control the voltage level of these pins when powering on ESP32-PICO-V3-02.

After reset release, the strapping pins work as normal-function pins.

Refer to Table 3 for a detailed boot-mode configuration by strapping pins.

Table 3: Strapping Pins

Voltage of Internal LDO (VDD_SDIO)					
Pin	Default	3.3 V		1.8 V	
MTDI	Pull-down	0		1	
Bootling Mode					
Pin	Default	SPI Boot		Download Boot	
GPIO0	Pull-up	1		0	
GPIO2	Pull-down	Don't-care		0	
Enabling/Disabling Debugging Log Print over U0TXD During Bootling					
Pin	Default	U0TXD Active		U0TXD Silent	
MTDO	Pull-up	1		0	
Timing of SDIO Slave					
Pin	Default	FE Sampling FE Output	FE Sampling RE Output	RE Sampling FE Output	RE Sampling RE Output
MTDO	Pull-up	0	0	1	1
GPIO5	Pull-up	0	1	0	1

* FE: falling-edge, RE: rising-edge

* Firmware can configure register bits to change the settings of "Voltage of Internal LDO (VDD_SDIO)" and "Timing of SDIO Slave", after bootling.

* The module integrates a 3.3 V SPI flash, so the pin MTDI cannot be set to 1 when the module is powered up.

4 Electrical Characteristics

4.1 Absolute Maximum Ratings

Stresses above those listed in *Absolute Maximum Ratings* may cause permanent damage to the device. These are stress ratings only and functional operation of the device at these or any other conditions beyond those indicated under *Recommended Operating Conditions* is not implied. Exposure to absolute-maximum-rated conditions for extended periods may affect device reliability.

Table 4: Absolute Maximum Ratings

Symbol	Parameter	Min	Max	Unit
VDD33	Power supply voltage	-0.3	3.6	V
T _{STORE}	Storage temperature	-40	85	°C

* Please see Appendix IO MUX of [ESP32 Series Datasheet](#) for IO's power domain.

4.2 Recommended Operating Conditions

Table 5: Recommended Operating Conditions

Symbol	Parameter	Min	Typ	Max	Unit
VDD33	Power supply voltage	3.0	3.3	3.6	V
I _{VDD}	Current delivered by external power supply	0.5	—	—	A
T	Operating ambient temperature	-40	—	85	°C

4.3 DC Characteristics (3.3 V, 25 °C)

Table 6: DC Characteristics (3.3 V, 25 °C)

Symbol	Parameter	Min	Typ	Max	Unit
C _{IN}	Pin capacitance	—	2	—	pF
V _{IH}	High-level input voltage	0.75 × VDD ¹	—	VDD ¹ + 0.3	V
V _{IL}	Low-level input voltage	-0.3	—	0.25 × VDD ¹	V
I _{IH}	High-level input current	—	—	50	nA
I _{IL}	Low-level input current	—	—	50	nA
V _{OH}	High-level output voltage	0.8 × VDD ¹	—	—	V
V _{OL}	Low-level output voltage	—	—	0.1 × VDD ¹	V

Cont'd on next page

Table 6 – cont'd from previous page

Symbol	Parameter	Min	Typ	Max	Unit	
I_{OH}	High-level source current ($V_{DD}^1 = 3.3$ V, $V_{OH} \geq 2.64$ V, output drive strength set to the maximum)	VDD3P3_CPU power domain ^{1,2}	—	40	—	mA
		VDD3P3_RTC power domain ^{1,2}	—	40	—	mA
		VDD_SDIO power domain ^{1,3}	—	20	—	mA
I_{OL}	Low-level sink current ($V_{DD}^1 = 3.3$ V, $V_{OL} = 0.495$ V, output drive strength set to the maximum)	—	28	—	mA	
R_{PU}	Resistance of internal pull-up resistor	—	45	—	k Ω	
R_{PD}	Resistance of internal pull-down resistor	—	45	—	k Ω	
V_{IL_nRST}	Low-level input voltage of CHIP_PU to power off the chip	—	—	0.6	V	

¹ Please see Appendix IO MUX of [ESP32 Series Datasheet](#) for IO's power domain. VDD is the I/O voltage for a particular power domain of pins.

² For VDD3P3_CPU and VDD3P3_RTC power domain, per-pin current sourced in the same domain is gradually reduced from around 40 mA to around 29 mA, $V_{OH} \geq 2.64$ V, as the number of current-source pins increases.

³ Pins occupied by flash and/or PSRAM in the VDD_SDIO power domain were excluded from the test.

4.4 Current Consumption Characteristics

Owing to the use of advanced power-management technologies, the module can switch between different power modes. For details on different power modes, please refer to Section *RTC and Low-Power Management* in [ESP32 Series Datasheet](#).

Table 7: Current Consumption Depending on RF Modes

Work mode	Description	Peak (mA)	
Active (RF working)	TX	802.11b, 20 MHz, 1 Mbps, @19.5 dBm	368
		802.11g, 20 MHz, 54 Mbps, @14 dBm	258
		802.11n, 20 MHz, MCS7, @13 dBm	248
		802.11n, 40 MHz, MCS7, @13 dBm	250
	RX ²	802.11b/g/n, 20 MHz	111
		802.11n, 40 MHz	117

¹ The current consumption measurements are taken with a 3.3 V supply at 25 °C of ambient temperature at the RF port. All transmitters' measurements are based on a 100% duty cycle.

² The current consumption figures for in RX mode are for cases when the peripherals are disabled and the CPU idle.

Table 8: Current Consumption Depending on Work Modes

Work mode	Description	Current consumption (Typ)	
Modem-sleep ^{1, 2}	The CPU is powered on ³	240 MHz	30 ~ 68 mA
		160 MHz	27 ~ 44 mA
		Normal speed: 80 MHz	20 ~ 31 mA
Light-sleep	—	0.8 mA	
Deep-sleep	The ULP coprocessor is powered on ⁴		150 μ A
	ULP sensor-monitored pattern ⁵		100 μ A @1% duty
	RTC timer + RTC memory		10 μ A
	RTC timer only		5 μ A
Power off	CHIP_PU is set to low level, the chip is powered off	1 μ A	

¹ The current consumption figures in Modem-sleep mode are for cases where the CPU is powered on and the cache idle.

² When Wi-Fi is enabled, the chip switches between Active and Modem-sleep modes. Therefore, current consumption changes accordingly.

³ In Modem-sleep mode, the CPU frequency changes automatically. The frequency depends on the CPU load and the peripherals used.

⁴ During Deep-sleep, when the ULP coprocessor is powered on, peripherals such as GPIO and RTC I2C are able to operate.

⁵ The "ULP sensor-monitored pattern" refers to the mode where the ULP coprocessor or the sensor works periodically. When ADC works with a duty cycle of 1%, the typical current consumption is 100 μ A.

4.5 Wi-Fi RF Characteristics

4.5.1 Wi-Fi RF Standards

Table 9: Wi-Fi RF Standards

Name	Description	
Center frequency range of operating channel ¹	2412 ~ 2462 MHz	
Wi-Fi wireless standard	IEEE 802.11b/g/n	
Data rate	20 MHz	11b: 1, 2, 5.5 and 11 Mbps 11g: 6, 9, 12, 18, 24, 36, 48, 54 Mbps 11n: MCS0-7, 72.2 Mbps (Max)
	40 MHz	11n: MCS0-7, 150 Mbps (Max)
Antenna type	PCB antenna, external antenna ²	

¹ Device should operate in the center frequency range allocated by regional regulatory authorities. Target center frequency range is configurable by software.

² For the modules that use external antennas, the output impedance is 50 Ω . For other modules without external antennas, the output impedance is irrelevant.

4.5.2 Transmitter Characteristics

Target TX power is configurable based on device or certification requirements. The default characteristics are provided in Table 10.

Table 10: TX Power Characteristics

Rate	Typ (dBm)
11b, 1 Mbps	18
11b, 11 Mbps	18
11g, 6 Mbps	18
11g, 54 Mbps	14
11n, HT20, MCS0	18
11n, HT20, MCS7	13
11n, HT40, MCS0	18
11n, HT40, MCS7	13

4.5.3 Receiver Characteristics

Table 11: RX Sensitivity Characteristics

Rate	Typ (dBm)
1 Mbps	-97
2 Mbps	-94
5.5 Mbps	-92
11 Mbps	-88
6 Mbps	-93
9 Mbps	-91
12 Mbps	-89
18 Mbps	-87
24 Mbps	-84
36 Mbps	-80
48 Mbps	-77
54 Mbps	-75
11n, HT20, MCS0	-92
11n, HT20, MCS1	-88
11n, HT20, MCS2	-86
11n, HT20, MCS3	-83
11n, HT20, MCS4	-80
11n, HT20, MCS5	-76
11n, HT20, MCS6	-74
11n, HT20, MCS7	-72
11n, HT40, MCS0	-89
11n, HT40, MCS1	-85
11n, HT40, MCS2	-83
11n, HT40, MCS3	-80
11n, HT40, MCS4	-76
11n, HT40, MCS5	-72
11n, HT40, MCS6	-71

Cont'd on next page

Table 11 – cont'd from previous page

Rate	Typ (dBm)
11n, HT40, MCS7	-69

Table 12: RX Maximum Input Level

Rate	Typ (dBm)
11b, 1 Mbps	5
11b, 11 Mbps	5
11g, 6 Mbps	0
11g, 54 Mbps	-8
11n, HT20, MCS0	0
11n, HT20, MCS7	-8
11n, HT40, MCS0	0
11n, HT40, MCS7	-8

Table 13: Adjacent Channel Rejection

Rate	Typ (dB)
11b, 11 Mbps	35
11g, 6 Mbps	27
11g, 54 Mbps	13
11n, HT20, MCS0	27
11n, HT20, MCS7	12
11n, HT40, MCS0	16
11n, HT40, MCS7	7

4.6 Bluetooth Radio

4.6.1 Receiver – Basic Data Rate

Table 14: Receiver Characteristics – Basic Data Rate

Parameter	Conditions	Min	Typ	Max	Unit
Sensitivity @0.1% BER	—	-90	-89	-88	dBm
Maximum received signal @0.1% BER	—	0	—	—	dBm
Co-channel C/I	—	—	+7	—	dB
Adjacent channel selectivity C/I	F = F0 + 1 MHz	—	—	-6	dB
	F = F0 - 1 MHz	—	—	-6	dB
	F = F0 + 2 MHz	—	—	-25	dB
	F = F0 - 2 MHz	—	—	-33	dB
	F = F0 + 3 MHz	—	—	-25	dB
	F = F0 - 3 MHz	—	—	-45	dB

Cont'd on next page

Table 14 – cont'd from previous page

Parameter	Conditions	Min	Typ	Max	Unit
Out-of-band blocking performance	30 MHz ~ 2000 MHz	-10	—	—	dBm
	2000 MHz ~ 2400 MHz	-27	—	—	dBm
	2500 MHz ~ 3000 MHz	-27	—	—	dBm
	3000 MHz ~ 12.5 GHz	-10	—	—	dBm
Intermodulation	—	-36	—	—	dBm

4.6.2 Transmitter – Basic Data Rate

Table 15: Transmitter Characteristics – Basic Data Rate

Parameter	Conditions	Min	Typ	Max	Unit
RF transmit power*	-	-	0	-	dBm
Gain control step	-	-	3	-	dB
RF power control range	-	-12	-	+9	dBm
+20 dB bandwidth	-	-	0.9	-	MHz
Adjacent channel transmit power	F = F0 ± 2 MHz	-	-55	-	dBm
	F = F0 ± 3 MHz	-	-55	-	dBm
	F = F0 ± > 3 MHz	-	-59	-	dBm
Δf_{1avg}	-	-	-	155	kHz
Δf_{2max}	-	127	-	-	kHz
$\Delta f_{2avg}/\Delta f_{1avg}$	-	-	0.92	-	-
ICFT	-	-	-7	-	kHz
Drift rate	-	-	0.7	-	kHz/50 μ s
Drift (DH1)	-	-	6	-	kHz
Drift (DH5)	-	-	6	-	kHz

* There are a total of eight power levels from 0 to 7, and the transmit power ranges from -12 dBm to 9 dBm. When the power level rises by 1, the transmit power increases by 3 dB. Power level 4 is used by default and the corresponding transmit power is 0 dBm.

4.6.3 Receiver – Enhanced Data Rate

Table 16: Receiver Characteristics – Enhanced Data Rate

Parameter	Conditions	Min	Typ	Max	Unit
$\pi/4$ DQPSK					
Sensitivity @0.01% BER	—	-90	-89	-88	dBm
Maximum received signal @0.01% BER	—	—	0	—	dBm
Co-channel C/I	—	—	11	—	dB
Adjacent channel selectivity C/I	F = F0 + 1 MHz	—	-7	—	dB
	F = F0 - 1 MHz	—	-7	—	dB
	F = F0 + 2 MHz	—	-25	—	dB
	F = F0 - 2 MHz	—	-35	—	dB
	F = F0 + 3 MHz	—	-25	—	dB

Cont'd on next page

Table 16 – cont'd from previous page

Parameter	Conditions	Min	Typ	Max	Unit
	F = F0 – 3 MHz	—	-45	—	dB
8DPSK					
Sensitivity @0.01% BER	—	-84	-83	-82	dBm
Maximum received signal @0.01% BER	—	—	-5	—	dBm
C/I c-channel	—	—	18	—	dB
Adjacent channel selectivity C/I	F = F0 + 1 MHz	—	2	—	dB
	F = F0 – 1 MHz	—	2	—	dB
	F = F0 + 2 MHz	—	-25	—	dB
	F = F0 – 2 MHz	—	-25	—	dB
	F = F0 + 3 MHz	—	-25	—	dB
	F = F0 – 3 MHz	—	-38	—	dB

4.6.4 Transmitter – Enhanced Data Rate

Table 17: Transmitter Characteristics – Enhanced Data Rate

Parameter	Conditions	Min	Typ	Max	Unit
RF transmit power (see note under Table 15)	—	—	0	—	dBm
Gain control step	—	—	3	—	dB
RF power control range	—	-12	—	+9	dBm
$\pi/4$ DQPSK max w0	—	—	-0.72	—	kHz
$\pi/4$ DQPSK max wi	—	—	-6	—	kHz
$\pi/4$ DQPSK max wi + w0	—	—	-7.42	—	kHz
8DPSK max w0	—	—	0.7	—	kHz
8DPSK max wi	—	—	-9.6	—	kHz
8DPSK max wi + w0	—	—	-10	—	kHz
$\pi/4$ DQPSK modulation accuracy	RMS DEVM	—	4.28	—	%
	99% DEVM	—	100	—	%
	Peak DEVM	—	13.3	—	%
8 DPSK modulation accuracy	RMS DEVM	—	5.8	—	%
	99% DEVM	—	100	—	%
	Peak DEVM	—	14	—	%
In-band spurious emissions	F = F0 \pm 1 MHz	—	-46	—	dBm
	F = F0 \pm 2 MHz	—	-44	—	dBm
	F = F0 \pm 3 MHz	—	-49	—	dBm
	F = F0 +/- > 3 MHz	—	—	-53	dBm
EDR differential phase coding	—	—	100	—	%

4.7 Bluetooth LE Radio

4.7.1 Receiver

Table 18: Receiver Characteristics – BLE

Parameter	Conditions	Min	Typ	Max	Unit
Sensitivity @30.8% PER	—	-94	-93	-92	dBm
Maximum received signal @30.8% PER	—	0	—	—	dBm
Co-channel C/I	—	—	+10	—	dB
Adjacent channel selectivity C/I	F = F0 + 1 MHz	—	-5	—	dB
	F = F0 - 1 MHz	—	-5	—	dB
	F = F0 + 2 MHz	—	-25	—	dB
	F = F0 - 2 MHz	—	-35	—	dB
	F = F0 + 3 MHz	—	-25	—	dB
	F = F0 - 3 MHz	—	-45	—	dB
Out-of-band blocking performance	30 MHz ~ 2000 MHz	-10	—	—	dBm
	2000 MHz ~ 2400 MHz	-27	—	—	dBm
	2500 MHz ~ 3000 MHz	-27	—	—	dBm
	3000 MHz ~ 12.5 GHz	-10	—	—	dBm
Intermodulation	—	-36	—	—	dBm

4.7.2 Transmitter

Table 19: Transmitter Characteristics – BLE

Parameter	Conditions	Min	Typ	Max	Unit
RF transmit power (see note under Table 15)	—	—	0	—	dBm
Gain control step	—	—	3	—	dB
RF power control range	—	-12	—	+9	dBm
Adjacent channel transmit power	F = F0 ± 2 MHz	—	-52	—	dBm
	F = F0 ± 3 MHz	—	-58	—	dBm
	F = F0 ± > 3 MHz	—	-60	—	dBm
$\Delta f_{1\text{avg}}$	—	—	—	265	kHz
$\Delta f_{2\text{max}}$	—	247	—	—	kHz
$\Delta f_{2\text{avg}}/\Delta f_{1\text{avg}}$	—	—	+0.92	—	—
ICFT	—	—	-10	—	kHz
Drift rate	—	—	0.7	—	kHz/50 μ s
Drift	—	—	2	—	kHz

5 Module Schematics

This is the reference design of the module.

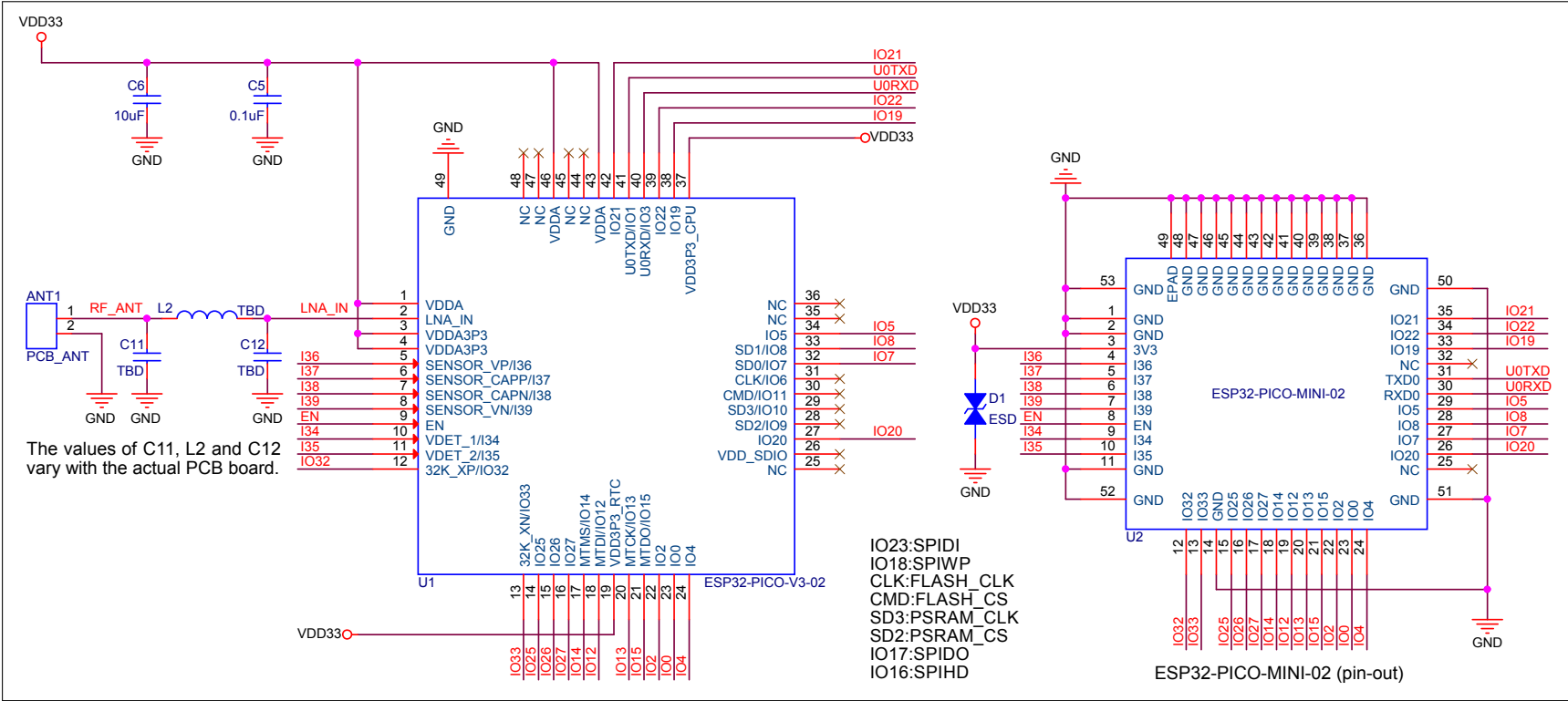

Figure 5: ESP32-PICO-MINI-02 Schematics

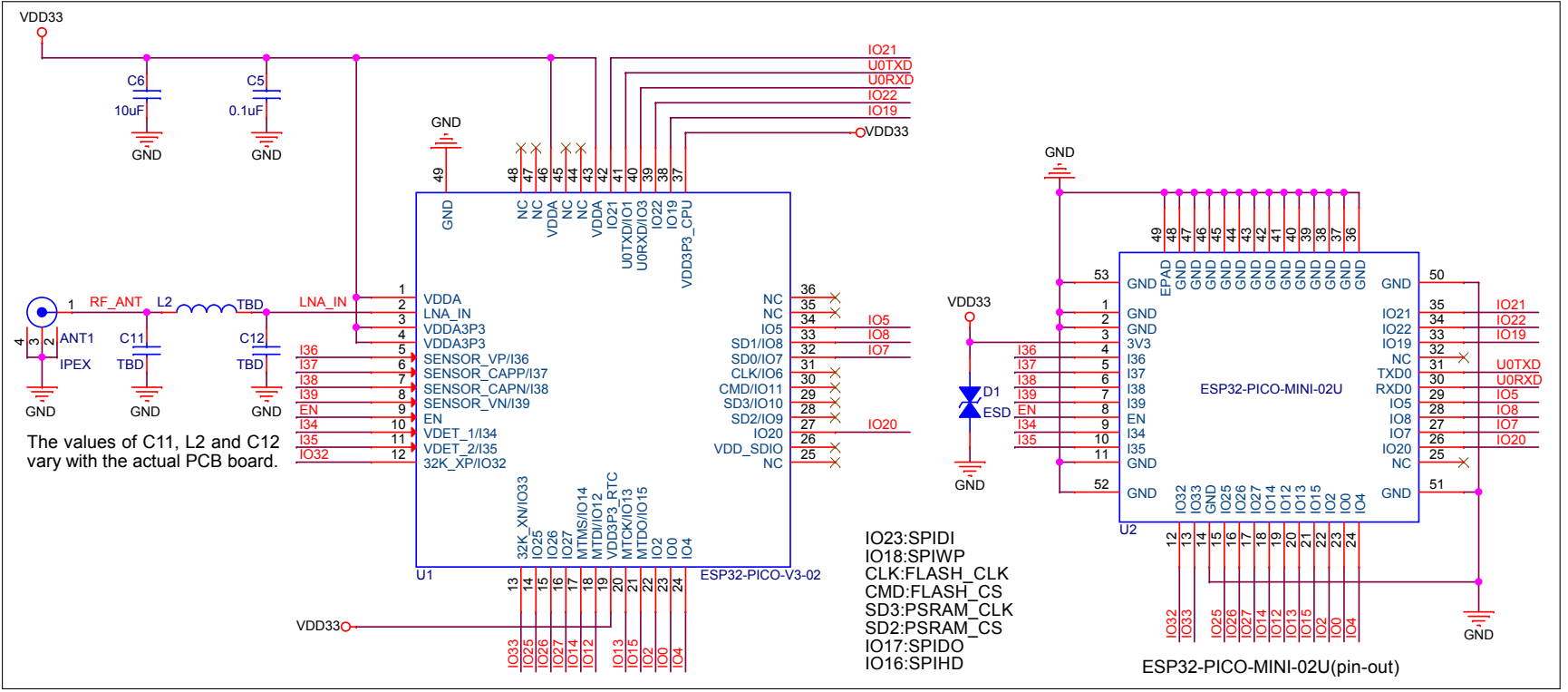

Figure 6: ESP32-PICO-MINI-02U Schematics

7 Physical Dimensions and PCB Land Pattern

7.1 Physical Dimensions

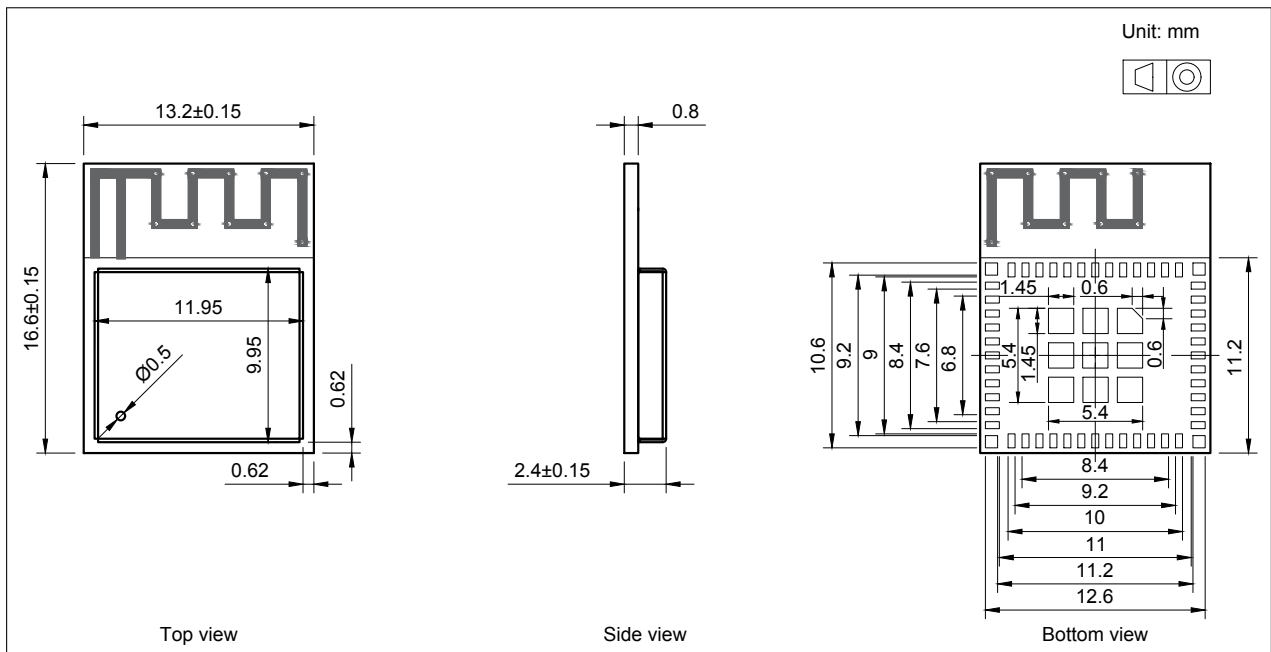

Figure 8: ESP32-PICO-MINI-02 Physical Dimensions

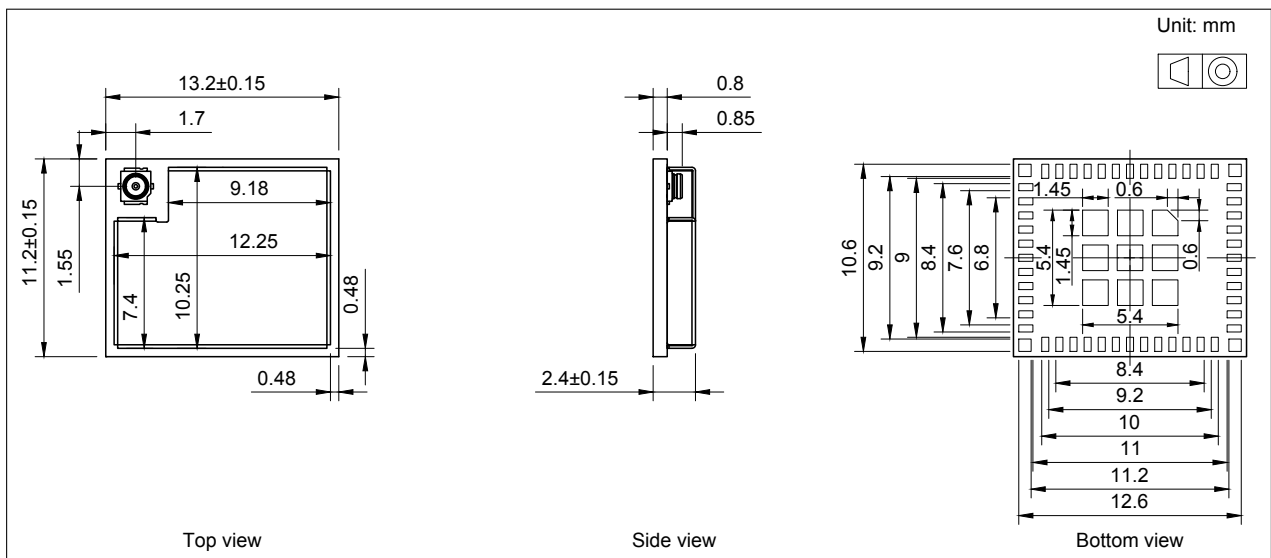

Figure 9: ESP32-PICO-MINI-02U Physical Dimensions

Note:

For information about tape, reel, and product marking, please refer to [Espressif Module Package Information](#).

7.2 Recommended PCB Land Pattern

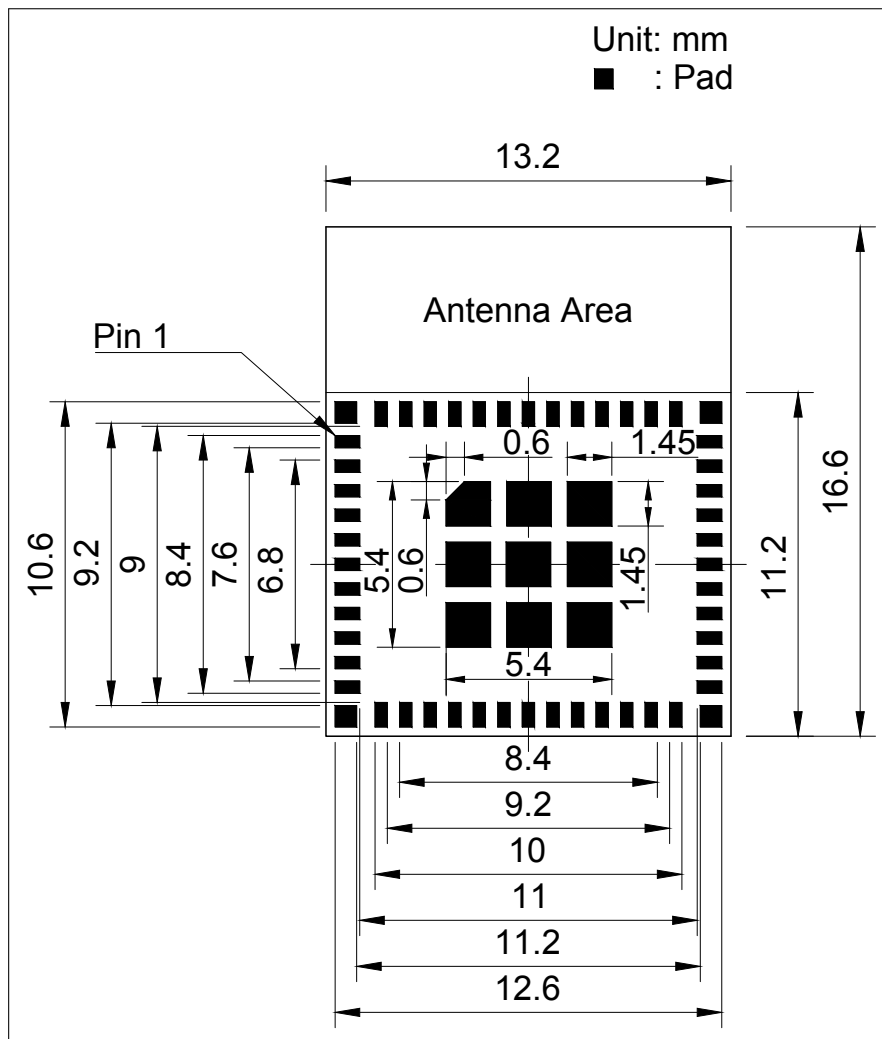

Figure 10: ESP32-PICO-MINI-02 Recommended PCB Land Pattern

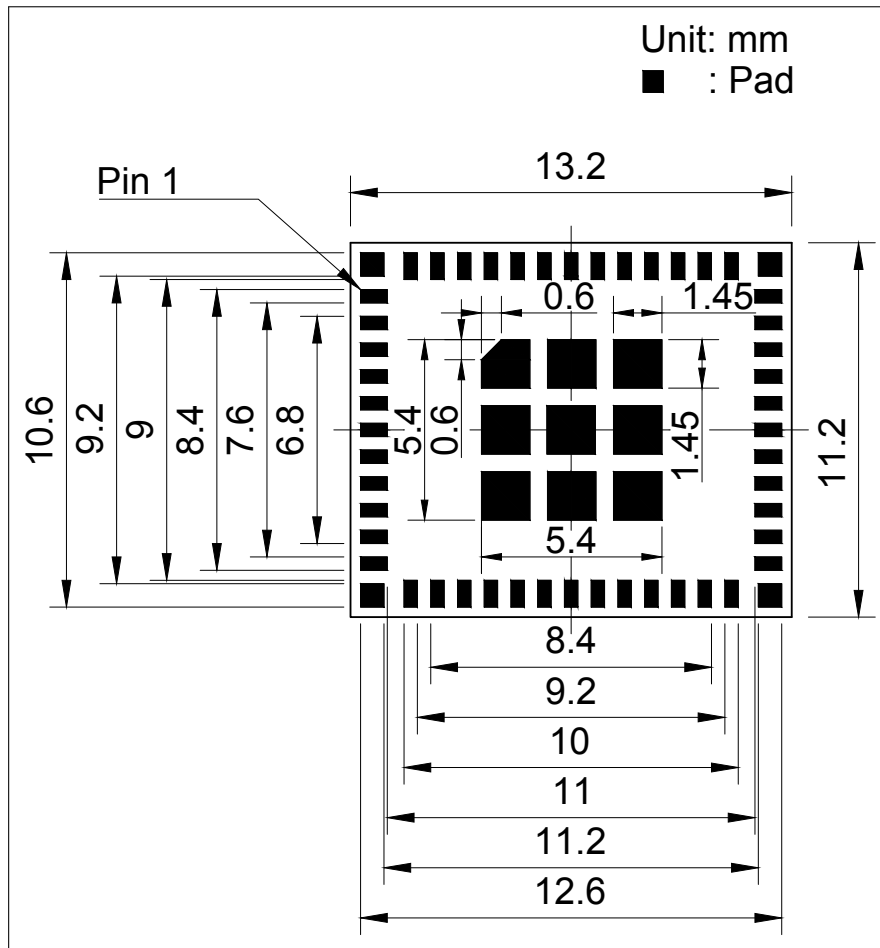

Figure 11: ESP32-PICO-MINI-02U Recommended PCB Land Pattern

7.3 Dimensions of External Antenna Connector

ESP32-PICO-MINI-02U uses the third generation external antenna connector as shown in Figure 12. This connector is compatible with the following connectors:

- W.FL Series connector from Hirose
- MHF III connector from I-PEX
- AMMC connector from Amphenol

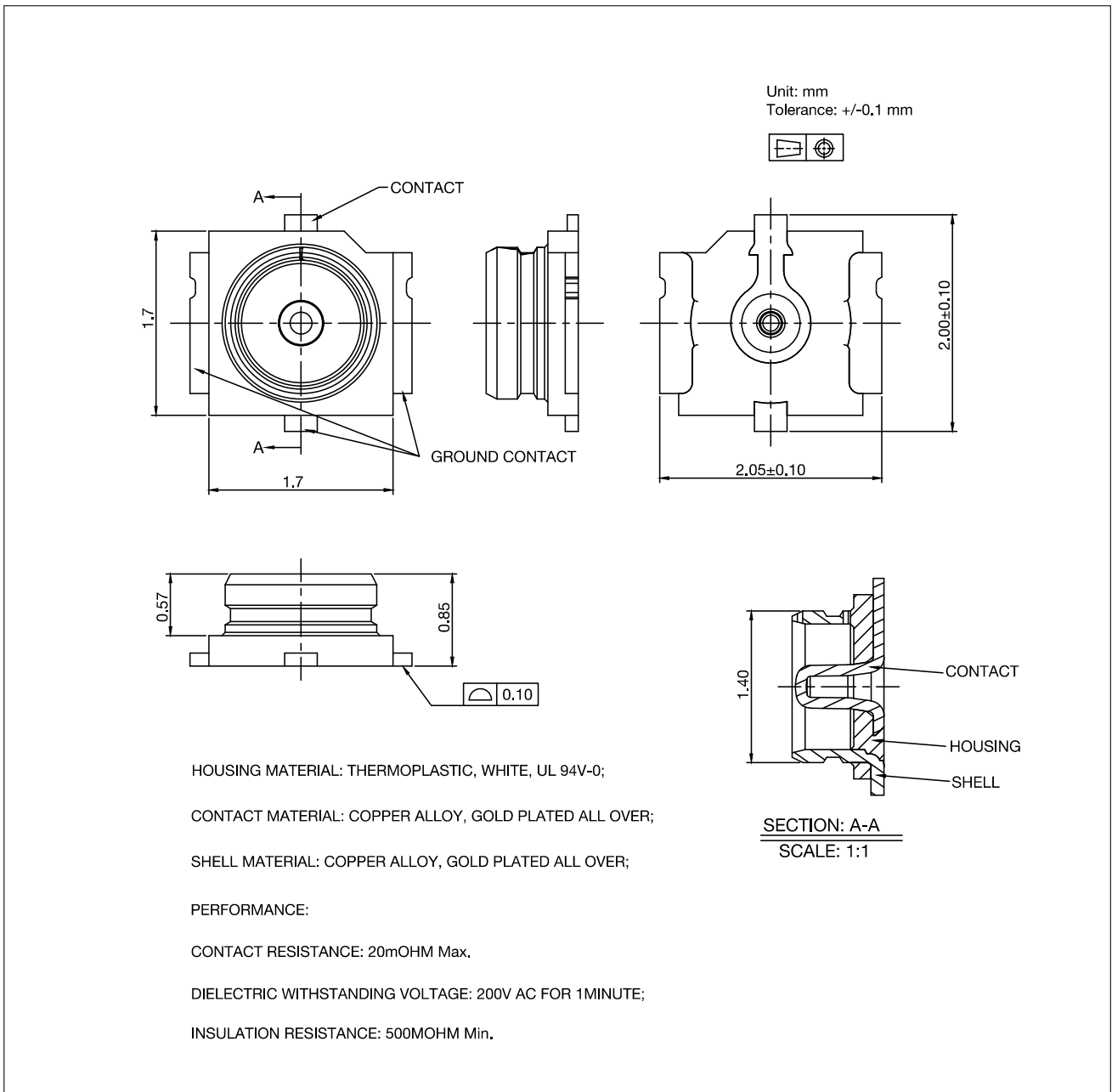

Figure 12: Dimensions of External Antenna Connector

8 Product Handling

8.1 Storage Conditions

The products sealed in moisture barrier bags (MBB) should be stored in a non-condensing atmospheric environment of $< 40\text{ }^{\circ}\text{C}$ and 90%RH. The module is rated at the moisture sensitivity level (MSL) of 3.

After unpacking, the module must be soldered within 168 hours with the factory conditions $25 \pm 5\text{ }^{\circ}\text{C}$ and 60 %RH. If the above conditions are not met, the module needs to be baked.

8.2 Electrostatic Discharge (ESD)

- Human body model (HBM): $\pm 2000\text{ V}$
- Charged-device model (CDM): $\pm 500\text{ V}$
- Air discharge: $\pm 6000\text{ V}$
- Contact discharge: $\pm 4000\text{ V}$

8.3 Reflow Profile

Solder the module in a single reflow.

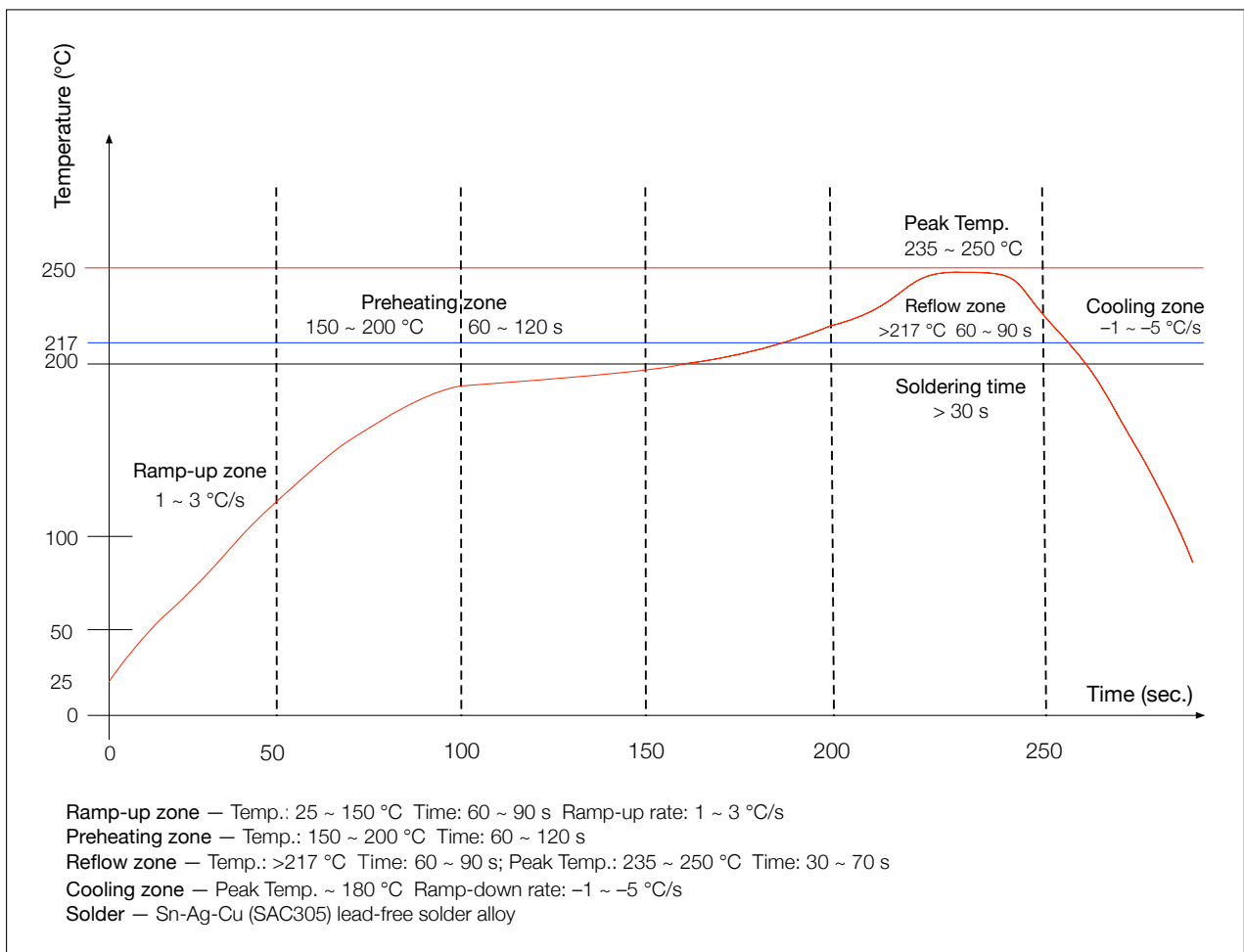

Figure 13: Reflow Profile

9 U.S. FCC Statement

Integration instructions for host product manufacturers according to KDB 996369 D03 OEM Manual v01:

1. List of applicable FCC rules

FCC Part 15 Subpart C 15.247 & 15.209

2. Specific operational use conditions

The module is a module with WiFi and BR,EDR,BLE function.

- Operation Frequency: WiFi 2412 ~2462 MHz;BT: 2402 ~ 2480 MHz
- Number of Channel:WiFi:12 ;BT: 40
- Modulation:WiFi:DSSS/OFDM ;BT:GFSK/ /4-DQPSK/8DPSK
- Type: PCB Antenna
- Gain: 3.96 dBi Max.

The module can be used for IoT applications with a maximum 3.96 dBi antenna. The host manufacturer installing this module into their product must ensure that the final composite product complies with the FCC requirements by a technical assessment or evaluation to the FCC rules, including the transmitter operation. The host manufacturer has to be aware not to provide information to the end user regarding how to install or remove this RF module in the user's manual of the end product which integrates this module. The end user manual shall include all required regulatory information/warning as show in this manual.

3. Limited module procedures

Not applicable. The module is a single module and complies with the requirement of FCC Part 15.212.

4. Trace antenna designs

Not applicable. The module has its own antenna, and does not need a host's printed board microstrip trace antenna, etc.

5. RF exposure considerations

The module must be installed in the host equipment such that at least 20cm is maintained between the antenna and users' body; and if RF exposure statement or module layout is changed, then the host product manufacturer required to take responsibility of the module through a change in FCC ID or new application. The FCC ID of the module cannot be used on the final product. In these circumstances, the host manufacturer will be responsible for re-evaluating the end product (including the transmitter) and obtaining a separate FCC authorization.

6. Antennas

Antenna Specification are as follows:

- Type: PCB Antenna
- Gain: 3.96 dBi
- Type: Ipex Antenna
- Gain: 2.33 dBi

This device is intended only for host manufacturers under the following conditions:

- The transmitter module may not be co-located with any other transmitter or antenna.

- The module shall be only used with the external antenna(s) that has been originally tested and certified with this module.
- The antenna must be either permanently attached or employ a 'unique' antenna coupler.

As long as the conditions above are met, further transmitter test will not be required. However, the host manufacturer is still responsible for testing their end-product for any additional compliance requirements required with this module installed (for example, digital device emissions, PC peripheral requirements, etc.).

7. Label and compliance information

Host product manufacturers need to provide a physical or e-label stating "Contains FCC ID: 2AC7Z-ESPPICOMINI" with their finished product.

8. Information on test modes and additional testing requirements

- Operation Frequency:WiFi 2412 ~2462 MHz;BT: 2402 ~ 2480 MHz
- Number of Channel:WiFi:12 ;BT: 40
- Modulation: WiFi:DSSS/OFDM ;BT:GFSK/ /4-DQPSK/8DPSK

Host manufacturer must perform test of radiated & conducted emission and spurious emission, etc., according to the actual test modes for a stand-alone modular transmitter in a host, as well as for multiple simultaneously transmitting modules or other transmitters in a host product. Only when all the test results of test modes comply with FCC requirements, then the end product can be sold legally.

9. Additional testing, Part 15 Subpart B compliant

The modular transmitter is only FCC authorized for FCC Part 15 Subpart C 15.247 & 15.209 and that the host product manufacturer is responsible for compliance to any other FCC rules that apply to the host not covered by the modular transmitter grant of certification. If the grantee markets their product as being Part 15 Subpart B compliant (when it also contains unintentional-radiator digital circuitry), then the grantee shall provide a notice stating that the final host product still requires Part 15 Subpart B compliance testing with the modular transmitter installed.

This equipment has been tested and found to comply with the limits for a Class B digital device, pursuant to Part 15 of the FCC Rules. These limits are designed to provide reasonable protection against harmful interference in a residential installation. This equipment generates, uses and can radiate radio frequency energy and, if not installed and used in accordance with the instructions, may cause harmful interference to radio communications. However, there is no guarantee that interference will not occur in a particular installation. If this equipment does cause harmful interference to radio or television reception, which can be determined by turning the equipment off and on, the user is encouraged to try to correct the interference by one of the following measures:

- Reorient or relocate the receiving antenna.
- Increase the separation between the equipment and receiver.
- Connect the equipment into an outlet on a circuit different from that to which the receiver is connected.
- Consult the dealer or an experienced radio/TV technician for help.

This device complies with Part 15 of the FCC Rules. Operation is subject to the following two conditions:

- This device may not cause harmful interference.
- This device must accept any interference received, including interference that may cause undesired operation.

Caution:

Any changes or modifications not expressly approved by the party responsible for compliance could void the user's authority to operate the equipment.

This equipment complies with FCC RF radiation exposure limits set forth for an uncontrolled environment. This device and its antenna must not be co-located or operating in conjunction with any other antenna or transmitter. The antennas used for this transmitter must be installed to provide a separation distance of at least 20 cm from all persons and must not be co-located or operating in conjunction with any other antenna or transmitter.

OEM Integration Instructions

This device is intended only for OEM integrators under the following conditions:

- The transmitter module may not be co-located with any other transmitter or antenna.
- The module shall be only used with the external antenna(s) that has been originally tested and certified with this module.

As long as the conditions above are met, further transmitter test will not be required. However, the OEM integrator is still responsible for testing their end-product for any additional compliance requirements required with this module installed (for example, digital device emissions, PC peripheral requirements, etc.).

Validity of Using the Module Certification

In the event that these conditions cannot be met (for example certain laptop configurations or co-location with another transmitter), then the FCC authorization for this module in combination with the host equipment is no longer considered valid and the FCC ID of the module cannot be used on the final product. In these circumstances, the OEM integrator will be responsible for re-evaluating the end product (including the transmitter) and obtaining a separate FCC authorization.

End Product Labeling

The final end product must be labeled in a visible area with the following: "Contains Transmitter Module FCC ID: 2AC7Z-ESPPICOMINI".

10 Related Documentation and Resources

Related Documentation

- [ESP32 Technical Reference Manual](#) – Detailed information on how to use the ESP32 memory and peripherals.
- [ESP32 Series Datasheet](#) – Specifications of the ESP32 hardware.
- [ESP32 Hardware Design Guidelines](#) – Guidelines on how to integrate the ESP32 into your hardware product.
- [ESP32 ECO and Workarounds for Bugs](#) – Correction of ESP32 design errors.
- *Certificates*
<http://espressif.com/en/support/documents/certificates>
- *ESP32 Product/Process Change Notifications (PCN)*
<http://espressif.com/en/support/documents/pcns>
- *ESP32 Advisories* – Information on security, bugs, compatibility, component reliability.
<http://espressif.com/en/support/documents/advisories>
- *Documentation Updates and Update Notification Subscription*
<http://espressif.com/en/support/download/documents>

Developer Zone

- [ESP-IDF Programming Guide for ESP32](#) – Extensive documentation for the ESP-IDF development framework.
- *ESP-IDF* and other development frameworks on GitHub.
<http://github.com/espressif>
- *ESP32 BBS Forum* – Engineer-to-Engineer (E2E) Community for Espressif products where you can post questions, share knowledge, explore ideas, and help solve problems with fellow engineers.
<http://esp32.com/>
- *The ESP Journal* – Best Practices, Articles, and Notes from Espressif folks.
<http://blog.espressif.com/>
- See the tabs *SDKs and Demos, Apps, Tools, AT Firmware*.
<http://espressif.com/en/support/download/sdks-demos>

Products

- *ESP32 Series SoCs* – Browse through all ESP32 SoCs.
<http://espressif.com/en/products/socs?id=ESP32>
- *ESP32 Series Modules* – Browse through all ESP32-based modules.
<http://espressif.com/en/products/modules?id=ESP32>
- *ESP32 Series DevKits* – Browse through all ESP32-based devkits.
<http://espressif.com/en/products/devkits?id=ESP32>
- *ESP Product Selector* – Find an Espressif hardware product suitable for your needs by comparing or applying filters.
<http://products.espressif.com/#/product-selector?language=en>

Contact Us

- See the tabs *Sales Questions, Technical Enquiries, Circuit Schematic & PCB Design Review, Get Samples* (Online stores), *Become Our Supplier, Comments & Suggestions*.
<http://espressif.com/en/contact-us/sales-questions>

Revision History

Date	Version	Release notes
2021-07-15	v1.0	Added ESP32-PICO-MINI-02U module. Updated the document formatting.
2021-03-16	v0.5	Preliminary release



www.espressif.com

Disclaimer and Copyright Notice

Information in this document, including URL references, is subject to change without notice.

ALL THIRD PARTY'S INFORMATION IN THIS DOCUMENT IS PROVIDED AS IS WITH NO WARRANTIES TO ITS AUTHENTICITY AND ACCURACY.

NO WARRANTY IS PROVIDED TO THIS DOCUMENT FOR ITS MERCHANTABILITY, NON-INFRINGEMENT, FITNESS FOR ANY PARTICULAR PURPOSE, NOR DOES ANY WARRANTY OTHERWISE ARISING OUT OF ANY PROPOSAL, SPECIFICATION OR SAMPLE.

All liability, including liability for infringement of any proprietary rights, relating to use of information in this document is disclaimed. No licenses express or implied, by estoppel or otherwise, to any intellectual property rights are granted herein.

The Wi-Fi Alliance Member logo is a trademark of the Wi-Fi Alliance. The Bluetooth logo is a registered trademark of Bluetooth SIG.

All trade names, trademarks and registered trademarks mentioned in this document are property of their respective owners, and are hereby acknowledged.

Copyright © 2022 Espressif Systems (Shanghai) Co., Ltd. All rights reserved.