

MEASUREMENT REPORT

FCC PART 24 & 27 LTE

FCC ID: 2AC6AC70

APPLICANT: Shenzhen Chainway Information Technology Co., Ltd.

Application Type: Certification

Product: Mobile Data Terminal

Model No.: C70

Brand Name: CHAINWAY

FCC Classification: PCS Licensed Transmitter Held to Ear (PCE)

FCC Rule Part(s): Part 2, Part 24 Subpart E, Part 27 Subpart L,
Part 27 Subpart M

Test Procedure(s): ANSI/TIA-603-E-2016, KDB 971168 D01v03
KDB 412172 D01v01r01

Test Date: October 31 ~ November 30, 2017

Reviewed By : 
(Kevin Guo)

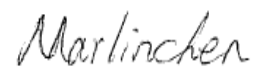
Approved By : 
(Marlin Chen)



The test results relate only to the samples tested.

This equipment has been shown to be capable of compliance with the applicable technical standards as indicated in the measurement report and was tested in accordance with the measurement procedures specified in §2.947. Test results reported herein relate only to the item(s) tested.

The test report shall not be reproduced except in full without the written approval of MRT Technology (Suzhou) Co., Ltd.

Revision History

Report No.	Version	Description	Issue Date	Note
1711RSU00107	Rev. 01	Initial report	12-30-2017	Valid

CONTENTS

Description	Page
§2.1033 General Information	5
1. INTRODUCTION	6
1.1. Scope	6
1.2. MRT Test Location	6
2. PRODUCT INFORMATION	7
2.1. Equipment Description.....	7
2.2. Product Specification Subjective to this Report.....	7
2.3. Description of Available Antennas	8
2.4. Device Capabilities	8
2.5. Test Configuration	9
2.6. EMI Suppression Device(s)/Modifications.....	9
2.7. Labeling Requirements.....	9
3. DESCRIPTION OF TEST	10
3.1. Evaluation Procedure	10
3.2. Occupied Bandwidth.....	10
3.3. Spurious and Harmonic Emissions at Antenna Terminal.....	10
3.4. Radiated Power and Radiated Spurious Emissions	11
4. TEST EQUIPMENT CALIBRATION DATE	12
5. SAMPLE CALCULATIONS	13
6. MEASUREMENT UNCERTAINTY.....	14
7. TEST RESULT	15
7.1. Summary	15
7.2. Occupied Bandwidth.....	17
7.2.1. Test Limit	17
7.2.2. Test Procedure used.....	17
7.2.3. Test Setting.....	17
7.2.4. Test Setup.....	17
7.2.5. Test Result.....	18
7.3. Band Edge Emissions at Antenna Terminal.....	42
7.3.1. Test Limit	42
7.3.2. Test Procedure Used	43
7.3.3. Test Setting.....	43
7.3.4. Test Setup.....	44

7.3.5.	Test Result.....	45
7.4.	Spurious and Harmonic Emissions at Antenna Terminal.....	67
7.4.1.	Test Limit	67
7.4.2.	Test Procedure Used	67
7.4.3.	Test Setting.....	67
7.4.4.	Test Setup.....	67
7.4.5.	Test Result.....	68
7.5.	Peak-Average Ratio.....	90
7.5.1.	Test Limit	90
7.5.2.	Test Procedure	90
7.5.3.	Test Setup.....	90
7.5.4.	Test Result.....	91
7.6.	Radiated Power (ERP/EIRP)	103
7.6.1.	Test Limit	103
7.6.2.	Test Procedure Used	103
7.6.3.	Test Setting.....	103
7.6.4.	Test Setup.....	104
7.6.5.	Test Result.....	105
7.7.	Radiated Spurious Emissions Measurements	119
7.7.1.	Test Limit	119
7.7.2.	Test Procedure Used	119
7.7.3.	Test Setting.....	119
7.7.4.	Test Setup.....	120
7.7.5.	Test Result.....	121
7.8.	Frequency Stability Under Temperature & Voltage Variations.....	126
7.8.1.	Test Limit	126
7.8.2.	Test Procedure	126
7.8.3.	Test Setup.....	126
7.8.4.	Test Result.....	127
8.	CONCLUSION.....	132

§2.1033 General Information

Applicant:	Shenzhen Chainway Information Technology Co., Ltd.
Applicant Address:	9/F, Building 2, Daqian Industrial Park, Longchang Rd., District 67, Bao'an, Shenzhen, China
Manufacturer:	Shenzhen Chainway Information Technology Co., Ltd.
Manufacturer Address:	9/F, Building 2, Daqian Industrial Park, Longchang Rd., District 67, Bao'an, Shenzhen, China
Test Site:	MRT Technology (Suzhou) Co., Ltd
Test Site Address:	D8 Building, No.2 Tian'edang Rd., Wuzhong Economic Development Zone, Suzhou, China
MRT Registration No.:	893164
MRT designation No.:	CN1166
Test Device Serial No.:	N/A <input type="checkbox"/> Production <input checked="" type="checkbox"/> Pre-Production <input type="checkbox"/> Engineering

Test Facility / Accreditations

Measurements were performed at MRT Laboratory located in Tian'edang Rd., Suzhou, China.

- MRT facility is a FCC registered (MRT Reg. No. 893164) test facility with the site description report on file and has met all the requirements specified in Section 2.948 of the FCC Rules.
- MRT facility is an IC registered (MRT Reg. No. 11384A-1) test laboratory with the site description on file at Industry Canada.
- MRT facility is a VCCI registered (R-20025, G-20034, C-20020, T-20020) test laboratory with the site description on file at VCCI Council.
- MRT Lab is accredited to ISO 17025 by the American Association for Laboratory Accreditation (A2LA) under the American Association for Laboratory Accreditation Program (A2LA Cert. No. 3628.01) in EMC, Telecommunications and Radio testing for FCC, Industry Canada, EU and TELEC Rules.



1. INTRODUCTION

1.1. Scope

Measurement and determination of electromagnetic emissions (EMC) of radio frequency devices including intentional and/or unintentional radiators for compliance with the technical rules and regulations of the Federal Communications Commission and the Industry Canada Certification and Engineering Bureau.

1.2. MRT Test Location

The map below shows the location of the MRT LABORATORY, its proximity to the Taihu Lake. These measurement tests were conducted at the MRT Technology (Suzhou) Co., Ltd. Facility located at D8 Building, No.2 Tian'edang Rd., Wuzhong Economic Development Zone, Suzhou, China. The detailed description of the measurement facility was found to be in compliance with the requirements of § 2.948 according to ANSI C63.4-2009 on September 30, 2013.



2. PRODUCT INFORMATION

2.1. Equipment Description

Product Name:	Mobile Data Terminal
Model No.:	C70
Brand Name:	CHAINWAY
Hardware Version:	C70SEA_mb_v12
Software Version:	C70A_MT6735_V1.2_AM_GIT55c9324_20171104
Wi-Fi Specification:	802.11a/b/g/n
Bluetooth Version	V4.0 single mode
GSM Operation Band (s):	GSM 850 / 900 / 1800 / 1900
WCDMA Operation Band (s):	Band II / IV / V
LTE Operation Band (s):	FDD Band 2 / 4 / 7 / 12 / 17
NFC:	13.56MHz
GPS:	1575.42MHz
Components	
Adapter	Model No.: GME 10D-050200FUu Input Power: 100 - 240V ~ 50/60Hz, Max. 0.28A Output Power: 5VDC 2.0A

2.2. Product Specification Subjective to this Report

Tx Frequency Range	LTE Band 2: 1850.7MHz ~ 1909.3MHz LTE Band 4: 1710.7MHz ~ 1754.3MHz LTE Band 7: 2502.5MHz ~ 2567.5MHz LTE Band 12: 699.7MHz ~ 715.3MHz LTE Band 17: 706.5MHz ~ 713.5MHz
Rx Frequency Range	LTE Band 2: 1930.7MHz ~ 1989.3MHz LTE Band 4: 2110.7MHz ~ 2154.3MHz LTE Band 7: 2622.5MHz ~ 2687.5MHz LTE Band 12: 729.0MHz ~ 745.9MHz LTE Band 17: 734.0MHz ~ 745.9MHz
Bandwidth	LTE Band 2: 1.4MHz / 3MHz / 5MHz / 10MHz / 15MHz / 20MHz LTE Band 4: 1.4MHz / 3MHz / 5MHz / 10MHz / 15MHz / 20MHz LTE Band 7: 5MHz / 10MHz / 15MHz / 20MHz LTE Band 12: 1.4MHz / 3MHz / 5MHz / 10MHz LTE Band 17: 5MHz / 10MHz
Type of Modulation	QPSK / 16-QAM

2.3. Description of Available Antennas

Antenna Type	Frequency Band	Max Peak Gain (dBi)
GPS Internal Antenna		
PIFA	1575.42MHz	0.92
2G Internal Antenna		
PIFA	GSM850	-1.00
	GSM1900	-0.40
3G Internal Antenna		
PIFA	WCDMA Band II	0.45
	WCDMA Band IV	-0.70
	WCDMA Band V	-1.15
4G Internal Antenna		
PIFA	FDD-LTE Band 2	0.50
	FDD-LTE Band 4	0.51
	FDD-LTE Band 7	-0.78
	FDD-LTE Band 12	-0.47
	FDD-LTE Band 17	-0.92
Wi-Fi Internal Antenna		
PIFA	2400 ~ 2483.5MHz	0.58
	5150 ~ 5250MHz	0.70
	5250 ~ 5350MHz	0.71
	5725 ~ 5850MHz	0.72
Bluetooth Internal Antenna		
PIFA	2400 ~ 2483.5MHz	0.58
NFC Internal Antenna		
PIFA	13.56MHz	1.20

2.4. Device Capabilities

This device contains the following capabilities:

GSM 850/900/1800/1900, WCDMA Band II/IV/V, LTE FDD Band 2/4/7/12/17, 2.4GHz WLAN (DTS), 5GHz WLAN (UNII), Bluetooth (v4.0 single mode), NFC

2.5. Test Configuration

The **Mobile Data Terminal** was tested per the guidance of ANSI/TIA-603-E-2016 and KDB 971168 D01v03. See section 3.0 of this report for a description of the radiated and antenna port conducted emissions tests.

2.6. EMI Suppression Device(s)/Modifications

No EMI suppression device(s) were added and no modifications were made during testing.

2.7. Labeling Requirements

Per 2.1074 & 15.19; Docket 95-19

The label shall be permanently affixed at a conspicuous location on the device; instruction manual or pamphlet supplied to the user and be readily visible to the purchaser at the time of purchase. However, when the device is so small wherein placement of the label with specified statement is not practical, only the FCC ID must be displayed on the device per Section 15.19(a)(5). Please see attachment for FCC ID label and label location.

3. DESCRIPTION OF TEST

3.1. Evaluation Procedure

The measurement procedures described in the “Land Mobile FM or PM - Communications Equipment - Measurements and Performance Standards” (ANSI/TIA-603-E-2016) and “Procedures for Compliance Measurement of the Fundamental Emission Power of Licensed Wideband (> 1 MHz) Digital Transmission Systems” (KDB 971168) were used in the measurement of the **Mobile Data Terminal**.

Deviation from measurement procedure.....None

3.2. Occupied Bandwidth

§2.1049

The occupied bandwidth, that is the frequency bandwidth such that, below its lower and above its upper frequency limits, the mean powers radiated are each equal to 0.5 percent of the total mean power radiated by a given emission shall be measured. The spectrum analyzers’ “occupied bandwidth” measurement function was used to record the occupied bandwidth in accordance with KDB 971168.

3.3. Spurious and Harmonic Emissions at Antenna Terminal

§2.1051 §24.238(a) §27.53(g) §27.53(h) §27.53(m)

The level of the carrier and the various conducted spurious and harmonic frequencies is measured by means of a calibrated spectrum analyzer. The spectrum is scanned from the lowest frequency generated in the equipment up to a frequency including its 10th harmonic. On any frequency outside a licensee’s frequency block, the power of any emission shall be attenuated below the transmitter power (P) by at least 43 + 10 log(P) dB. Compliance with these provisions is based on the use of measurement instrumentation employing a resolution bandwidth of 1MHz or greater for Part 24 and Part 27. However, in the 1 MHz bands immediately outside and adjacent to the frequency block a resolution bandwidth of at least one percent of the emission bandwidth of the fundamental emission of the transmitter may be employed. The emission bandwidth is defined as the width of the signal between two points, one below the carrier center frequency and one above the carrier center frequency, outside of which all emission are attenuated at least 26 dB below the transmitter power.

3.4. Radiated Power and Radiated Spurious Emissions

§2.1053 §24.232(c) §24.238(a) § 27.50(c.10) (d.4)(h.2) § 27.53(g) (h) (m)

The radiated test facilities consisted of an indoor 3 meter semi-anechoic chamber used for final measurement and exploratory measurements, when necessary. The measurement area is contained within the semi-anechoic chamber which is shielded from any ambient interference. For measurements above 1GHz absorbers are arranged on the floor between the turn table and the antenna mast in such a way so as to maximize the reduction of reflections. For measurements below 1GHz, the absorbers are removed. A MF Model 210SS turntable is used for radiated measurement. It is a continuously rotatable, remote-controlled, metallic turntable and 2 meters (6.56 ft.) in diameter. The turn table is flush with the raised floor of the chamber in order to maintain its function as a ground plane. A 80cm high PVC support structure is placed on top of the turntable.

The equipment under test was transmitting while connected to its integral antenna and is placed on a wooden turntable 80cm above the ground plane and 3 meters from the receive antenna. The receive antenna height is adjusted between 1 and 4 meter height, the turntable is rotated through 360 degrees, and the EUT is manipulated through all orthogonal planes representative of its typical use to achieve the highest reading on the receive spectrum analyzer. Radiated power levels are also investigated with the receive antenna horizontally and vertically polarized. The maximized power level is recorded using the spectrum analyzer “Channel Power” function with the integration band set to the emissions’ occupied bandwidth, a RMS detector, RBW = 100kHz, VBW = 300kHz, and a 1 second sweep time over a minimum of 10 sweeps, per the guidelines of KDB 971168.

Per the guidance of ANSI/TIA-603-E-2016, a half-wave dipole is then substituted in place of the EUT. For emissions above 1GHz, a horn antenna is substituted in place of the EUT. The substitute antenna is driven by a signal generator with the level of the signal generator being adjusted to obtain the same receive spectrum analyzer level previously recorded from the spurious emission from the EUT. The power of the emission is calculated using the following formula:

$$P_d \text{ [dBm]} = P_g \text{ [dBm]} - \text{cable loss} \text{ [dB]} + \text{antenna gain} \text{ [dBd/dBi]}$$

Where, P_d is the dipole equivalent power, P_g is the generator output into the substitution antenna, and the antenna gain is the gain of the substitute antenna used relative to either a half-wave dipole (dBd) or an isotropic source (dBi). The substitute level is equal to $P_g \text{ [dBm]} - \text{cable loss} \text{ [dB]}$.

The calculated P_d levels are then compared to the absolute spurious emission limit of -13dBm which is equivalent to the required minimum attenuation of $43 + 10 \cdot \log_{10}(\text{Power [Watts]})$.

4. TEST EQUIPMENT CALIBRATION DATE

Radiated Emissions - AC2

Instrument	Manufacturer	Type No.	Asset No.	Cali. Interval	Cali. Due Date
Spectrum Analyzer	Agilent	N9038A	MRTSUE06125	1 year	2018/08/18
EMI Test Receiver	R&S	ESR7	MRTSUE06001	1 year	2018/08/18
Radio Communication Tester	R&S	CMU 200	MRTSUE06009	1 year	2018/10/27
Wideband Radio Communication Tester	R&S	CMW 500	MRTSUE06243	1 year	2018/02/14
Preamplifier	Schwarzbeck	BBV 9721	MRTSUE06121	1 year	2018/04/15
Loop Antenna	Schwarzbeck	FMZB1519	MRTSUE06025	1 year	2018/11/21
Bilog Period Antenna	Schwarzbeck	VULB9162	MRTSUE06022	1 year	2018/10/21
Broad Band Horn Antenna	Schwarzbeck	BBHA 9120D	MRTSUE06171	1 year	2018/11/18
Broadband Horn Antenna	Schwarzbeck	BBHA9170	MRTSUE06024	1 year	2018/01/04
Digital Thermometer & Hygrometer	Minggao	ETH529	MRTSUE06170	1 year	2018/12/12
Anechoic Chamber	RIKEN	Chamber-AC2	MRTSUE06213	1 year	2018/05/10

Conducted Test Equipment - TR3

Instrument	Manufacturer	Type No.	Asset No.	Cali. Interval	Cali. Due Date
Spectrum Analyzer	Agilent	N9020A	MRTSUE06106	1 year	2018/04/25
Radio Communication Tester	R&S	CMU 200	MRTSUE06009	1 year	2018/10/27
Wideband Radio Communication Tester	R&S	CMW 500	MRTSUE06243	1 year	2018/02/14
DC Power Supply	GWINSTEK	DPS-3303C	MRTSUE06064	N/A	N/A
Temperature Humidity Chamber	BAOYT	BYH-150CL	MRTSUE06051	1 year	2018/12/06
Thermohygrometer	Testo	608-H1	MRTSUE06401	1 year	2018/08/14

Software	Version	Function
e3	V8.3.5	EMI Test Software

5. SAMPLE CALCULATIONS

QPSK Emission Designator

Emission Designator = 250KGXW

LTE BW = 250 kHz

G = Phase Modulation

X = Cases not otherwise covered

W = Combination (Audio/Data)

16-QAM Emission Designator

Emission Designator = 250KG7W

LTE BW = 250 kHz

G = Phase Modulation

7 = Quantized/Digital Info

W = Combination (Audio/Data)

Spurious Radiated Emission

Example: Mid. CHLTE Mode 2nd Harmonic (1564 MHz)

The receive spectrum analyzer reading at 3 meters with the EUT on the turntable was -81.0dBm.

The gain of the substituted antenna is 8.1dBi. The signal generator connected to the substituted antenna terminals is adjusted to produce a reading of -81.0dBm on the spectrum analyzer. The loss of the cable between the signal generator and the terminals of the substituted antenna is 2.0 dB at 1564MHz. So 6.1 dB is added to the signal generator reading of -30.9dBm yielding -24.80dBm. The fundamental EIRP was 25.50dBm so this harmonic was 25.50dBm - (-24.80).

6. MEASUREMENT UNCERTAINTY

Where relevant, the following test uncertainty levels have been estimated for tests performed on the EUT as specified in CISPR 16-4-2. This uncertainty represents an expanded uncertainty expressed at approximately the 95% confidence level using a coverage factor of $k = 2$.

AC Conducted Emission Measurement - SR2
Measuring Uncertainty for a Level of Confidence of 95% ($U=2U_c(y)$): 150kHz~30MHz: 3.46dB
Radiated Emission Measurement - AC2
Measuring Uncertainty for a Level of Confidence of 95% ($U=2U_c(y)$): 9kHz ~ 1GHz: 4.18dB 1GHz ~ 25GHz: 4.76dB

7. TEST RESULT

7.1. Summary

Company Name: Shenzhen Chainway Information Technology Co., Ltd.
FCC ID: 2AC6AC70
FCC Classification: PCS Licensed Transmitter Held to Ear (PCE)
Mode(s): LTE

FCC Part Section(s)	Test Description	Test Limit	Test Condition	Test Result	Reference
2.1049	Occupied bandwidth	N/A	Conducted	Pass	Section 7.2
2.1051 & 24.238(a) & 27.53(g) & 27.53(h)	Band Edge / Conducted Spurious Emissions (Band 2 & 4 & 12 & 17)	$> 43 + \log_{10} (P[\text{Watts}])$ at Band Edge and for all out-of-band emissions		Pass	Section 7.3
27.53(m)(4)	Band Edge / Conducted Spurious Emissions (Band 7)	$> 55 + \log_{10} (P[\text{Watts}])$ at Band Edge and for all out-of-band emissions		Pass	Section 7.4
24.232(d)	Peak-Average Ratio	$< 13 \text{ dB}$		Pass	Section 7.5
2.1046	Transmitter Conducted Output Power	N/A		Section 7.6	Pass
27.50(c)(10)	Effective Radiated Power (Band 12 & 17)	$< 3 \text{ Watts max. ERP}$			Pass
24.232(c), 27.50(h)(2)	Equivalent Isotropic Radiated Power (Band 2 & 7)	$< 2 \text{ Watts max. EIRP}$			Pass
27.50(d)(4)	Equivalent Isotropic Radiated Power (Band 4)	$< 1 \text{ Watts max. EIRP}$			Pass
2.1055 & 24.235 & 27.54	Frequency Stability	fundamental emissions stay within authorized frequency block (Part 24, 27)			Pass
2.1053, 24.238(a), 27.53(g), 27.53(h)	Undesirable Emissions (Band 2 & 4 & 12 & 17)	$> 43 + \log_{10} (P[\text{Watts}])$ for all out-of-band emissions		Radiated	Pass
2.1053, 27.53(m)(4)	Undesirable Emissions (Band 7)	$> 55 + \log_{10} (P[\text{Watts}])$ for all out-of-band emissions			

Notes:

1. All modes of operation and data rates were investigated. The test results shown in the following sections represent the worst case emissions.
2. The analyzer plots shown in Section 7.2, 7.3, 7.4, 7.5 were all taken with a correction table loaded into the analyzer. The correction table was used to account for the losses of the cables, directional couplers, and attenuators used as part of the system to maintain a link between the call box and the EUT at all frequencies of interest.
3. All antenna port conducted emissions testing was performed on a test bench with the antenna port of the EUT connected to the spectrum analyzer through calibrated cables, attenuators, and couplers.
4. The device is investigated from 30MHz to 10 times of fundamental signal for radiated spurious emission test under different RB size/offset and modulation in exploratory test. Subsequently, only the worst case data are reported.

7.2. Occupied Bandwidth

7.2.1. Test Limit

N/A

7.2.2. Test Procedure used

KDB 971168 D01v03 - Section 4.1 & ANSI/TIA-603-E-2016

7.2.3. Test Setting

1. The spectrum analyzer center frequency is set to the nominal EUT channel center frequency.
The span range for the spectrum analyzer shall be between two and five times the anticipated OBW. RBW = approximately 1% of the emission bandwidth.
2. The nominal resolution bandwidth (RBW) shall be in the range of 1 to 5 % of the anticipated OBW, and the VBW shall be at least 3 times the RBW.
3. Set the detection mode to peak, and the trace mode to max hold.
4. Use the 99 % power bandwidth function of the spectrum analyzer (if available) and report the measured bandwidth.

7.2.4. Test Setup

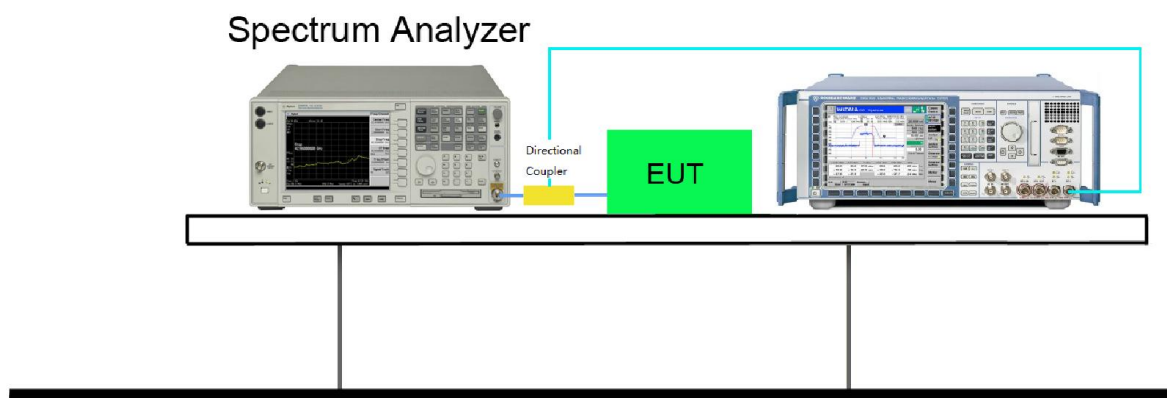

7.2.5. Test Result

Product	Mobile Data Terminal	Temperature	25°C
Test Engineer	Milo Li	Relative Humidity	52%
Test Site	TR3	Test Date	2017/11/30

LTE Band 2 99% Occupied Bandwidth (MHz)												
BW	1.4MHz		3MHz		5MHz		10MHz		15MHz		20MHz	
Mod.	QPSK	16-QAM	QPSK	16-QAM	QPSK	16-QAM	QPSK	16-QAM	QPSK	16-QAM	QPSK	16-QAM
Low CH	1.10	1.09	2.74	2.75	4.53	4.51	9.05	9.05	13.48	13.48	17.92	17.98
Mid. CH	1.10	1.10	2.74	2.73	4.52	4.53	9.03	9.04	13.45	13.49	17.94	17.96
High CH	1.09	1.10	2.73	2.72	4.51	4.53	9.05	9.05	13.49	13.49	18.01	17.96
LTE Band 4 99% Occupied Bandwidth (MHz)												
Low CH	1.10	1.09	2.73	2.74	4.54	4.51	9.06	9.07	13.51	13.49	17.97	18.00
Mid. CH	1.10	1.10	2.74	2.73	4.52	4.54	9.02	9.06	13.45	13.50	17.94	17.96
High CH	1.09	1.10	2.73	2.73	4.51	4.53	9.02	9.04	13.48	13.49	17.97	17.96
LTE Band 7 99% Occupied Bandwidth (MHz)												
Low CH	-	-	-	-	4.51	4.53	9.06	9.06	13.51	13.50	17.97	18.01
Mid. CH	-	-	-	-	4.53	4.52	9.02	9.04	13.45	13.50	17.98	17.98
High CH	-	-	-	-	4.52	4.54	9.06	9.04	13.49	13.50	17.98	17.95
LTE Band 12 99% Occupied Bandwidth (MHz)												
Low CH	1.10	1.10	2.74	2.75	4.55	4.53	9.08	9.07	-	-	-	-
Mid. CH	1.09	1.09	2.73	2.72	4.49	4.50	8.94	8.93	-	-	-	-
High CH	1.10	1.10	2.74	2.74	4.53	4.57	9.05	9.06	-	-	-	-
LTE Band 17 99% Occupied Bandwidth (MHz)												
Low CH	-	-	-	-	4.53	4.50	8.96	8.97	-	-	-	-
Mid. CH	-	-	-	-	4.51	4.53	9.00	9.02	-	-	-	-
High CH	-	-	-	-	4.53	4.55	9.05	9.05	-	-	-	-

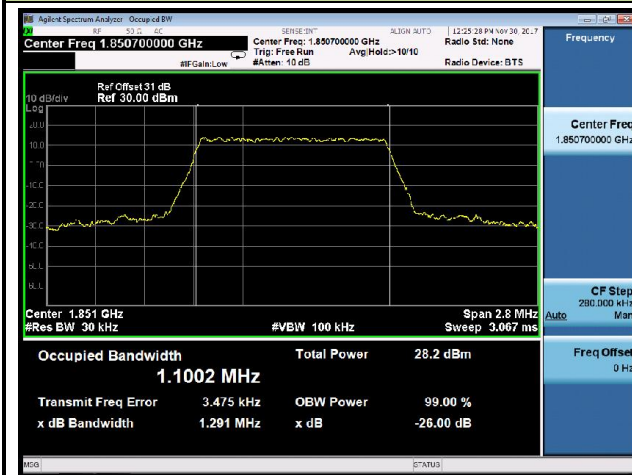
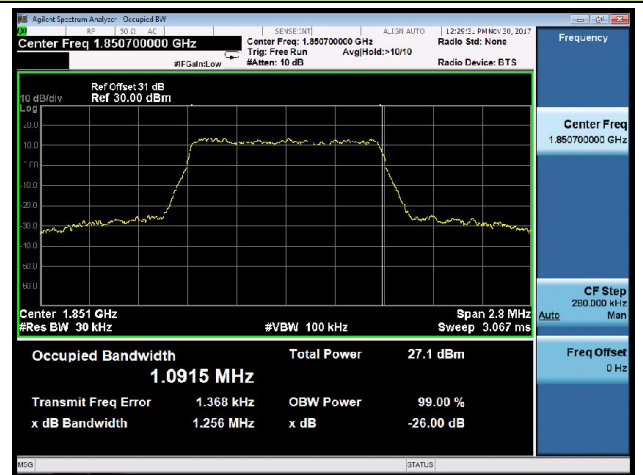
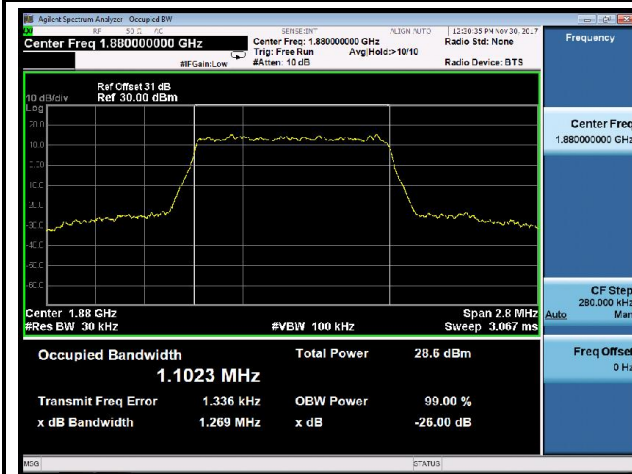
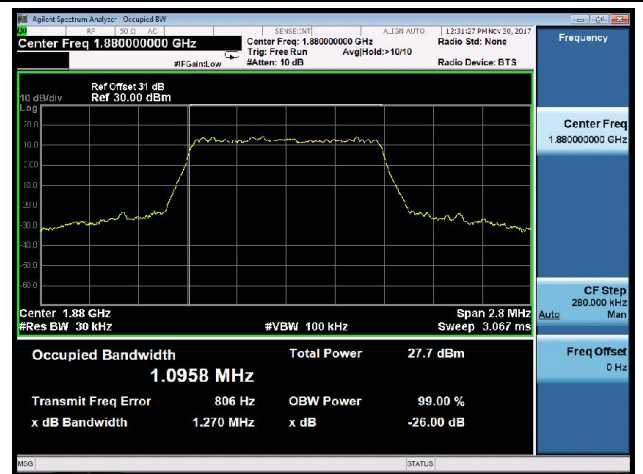
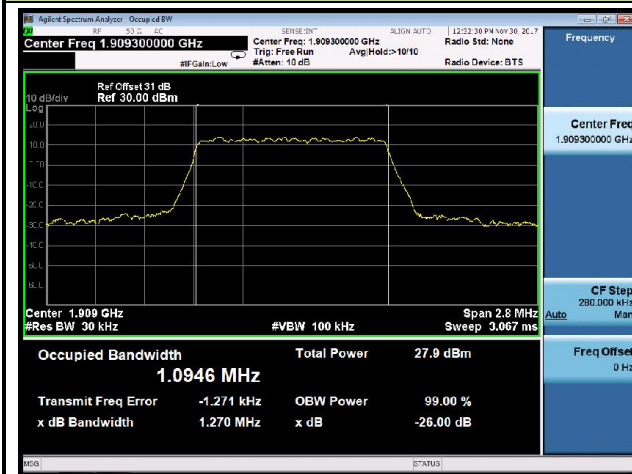
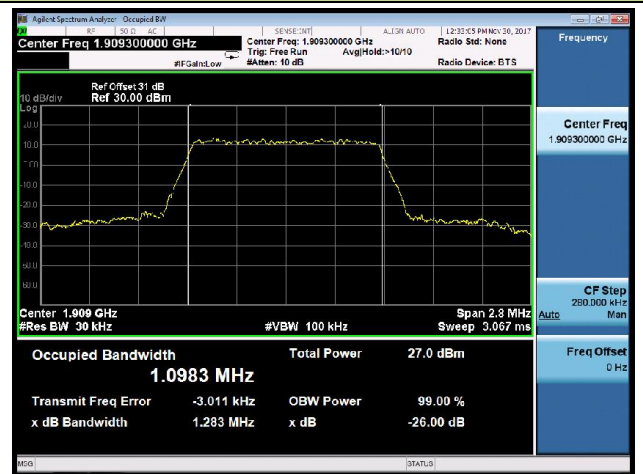

LTE Band 2 26dB Occupied Bandwidth (MHz)												
BW	1.4MHz		3MHz		5MHz		10MHz		15MHz		20MHz	
Mod.	QPSK	16-QAM	QPSK	16-QAM	QPSK	16-QAM	QPSK	16-QAM	QPSK	16-QAM	QPSK	16-QAM
Low CH	1.29	1.26	3.03	3.05	5.08	5.04	10.20	10.08	14.96	14.82	19.46	19.58
Mid. CH	1.27	1.27	3.03	3.03	5.09	5.08	10.09	10.06	14.89	14.87	19.54	19.55
High CH	1.27	1.28	3.04	3.05	5.06	5.06	10.18	10.14	14.97	14.82	19.85	19.65
LTE Band 4 26dB Occupied Bandwidth (MHz)												
Low CH	1.29	1.26	3.04	3.04	5.09	5.05	10.19	10.09	14.85	14.86	19.50	19.62
Mid. CH	1.27	1.28	3.03	3.04	5.08	5.07	10.04	10.14	14.81	14.86	19.52	19.65
High CH	1.27	1.28	3.04	3.04	5.07	5.09	10.10	10.11	14.97	14.85	19.86	19.59
LTE Band 7 26dB Occupied Bandwidth (MHz)												
Low CH	-	-	-	-	5.05	5.08	10.16	10.11	14.87	14.86	19.52	19.61
Mid. CH	-	-	-	-	5.07	5.04	10.04	10.11	14.77	14.88	19.56	19.73
High CH	-	-	-	-	5.09	5.07	10.16	10.08	14.82	14.90	19.68	19.52
LTE Band 12 26dB Occupied Bandwidth (MHz)												
Low CH	1.30	1.29	3.04	3.05	5.10	5.11	10.10	10.01	-	-	-	-
Mid. CH	1.28	1.26	3.02	3.03	5.02	5.03	9.97	9.98	-	-	-	-
High CH	1.26	1.28	3.05	3.05	5.08	5.13	10.02	10.01	-	-	-	-
LTE Band 17 26dB Occupied Bandwidth (MHz)												
Low CH	-	-	-	-	5.03	5.04	9.99	10.00	-	-	-	-
Mid. CH	-	-	-	-	5.03	4.99	10.09	9.97	-	-	-	-
High CH	-	-	-	-	5.06	5.08	10.05	10.00	-	-	-	-

LTE Band 2 99% & 26dB Occupied Bandwidth
Low CH / 1.4MHz / QPSK

Low CH / 1.4MHz / 16-QAM

Mid. CH / 1.4MHz / QPSK

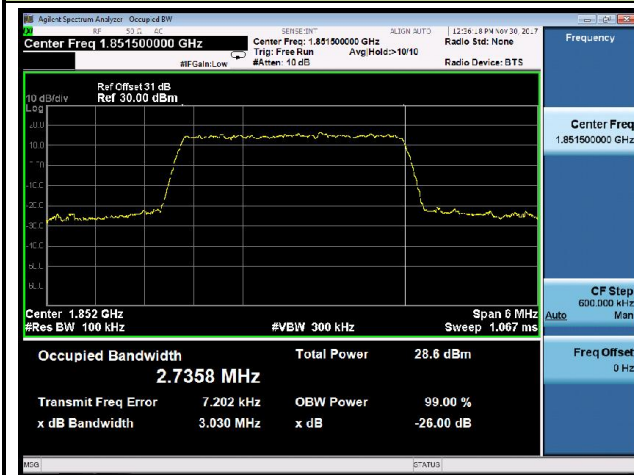
Mid. CH / 1.4MHz / 16-QAM

High CH / 1.4MHz / QPSK

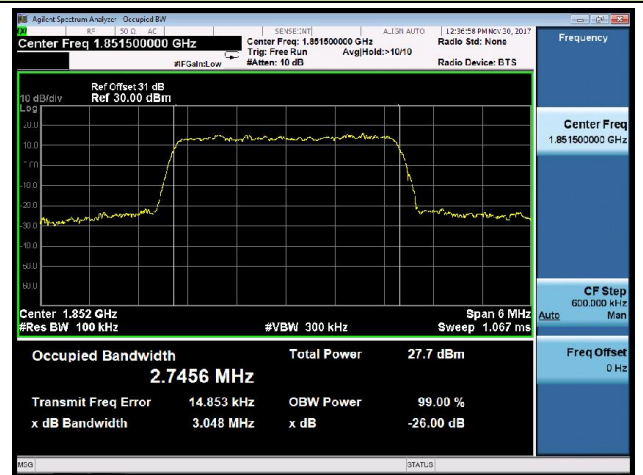
High CH / 1.4MHz / 16-QAM

LTE Band 2 99% & 26dB Occupied Bandwidth

Low CH / 3MHz / QPSK



Low CH / 3MHz / 16-QAM



Mid. CH / 3MHz / QPSK

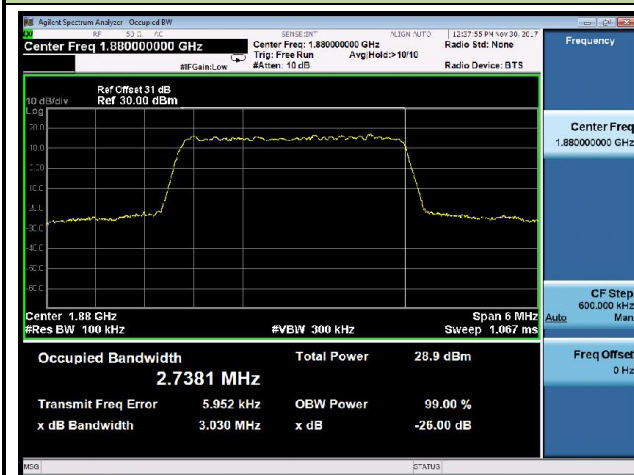

Mid. CH / 3MHz / 16-QAM

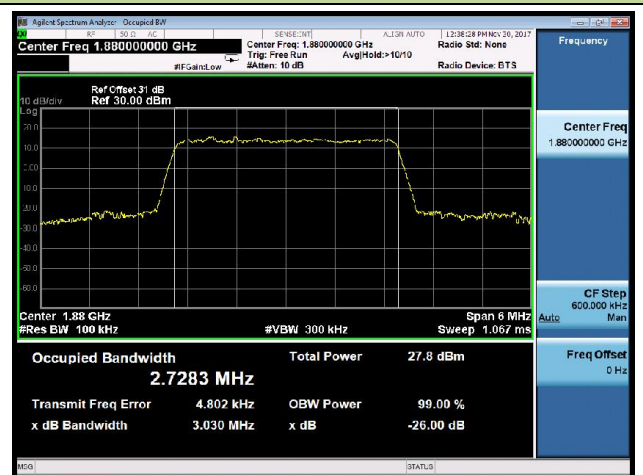

High CH / 3MHz / QPSK

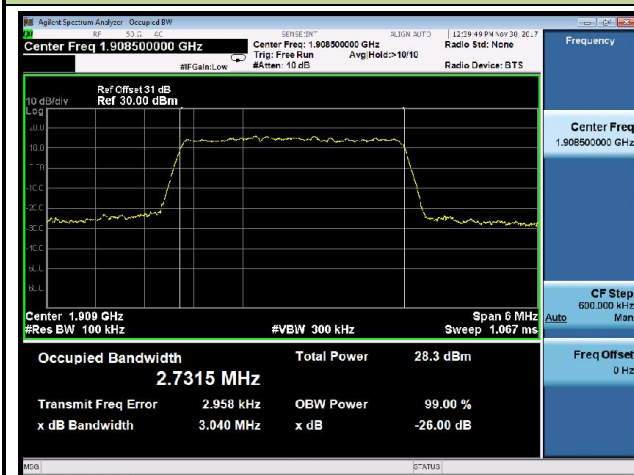

High CH / 3MHz / 16-QAM

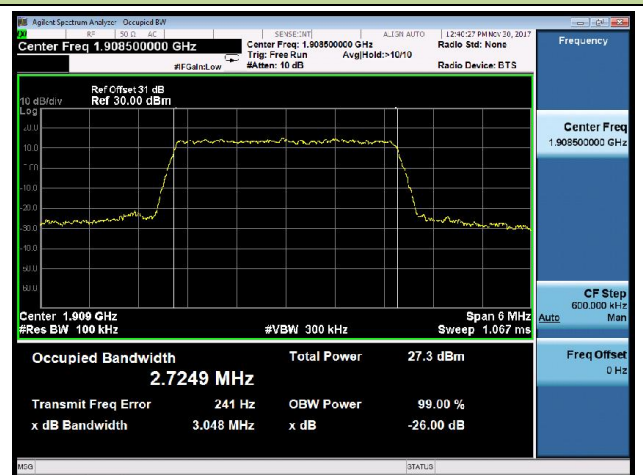

LTE Band 2 99% & 26dB Occupied Bandwidth

Low CH / 5MHz / QPSK

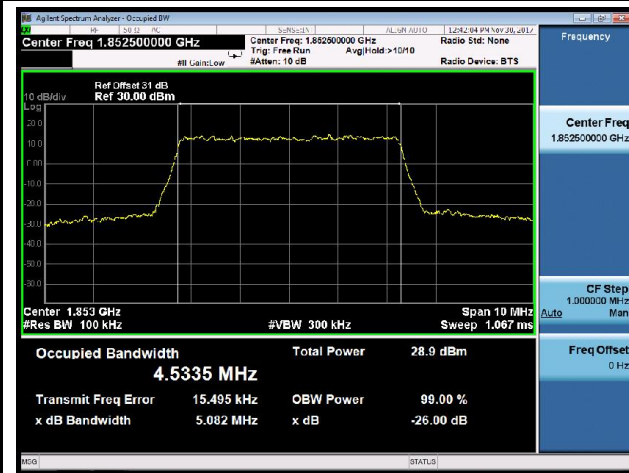

Low CH / 5MHz / 16-QAM

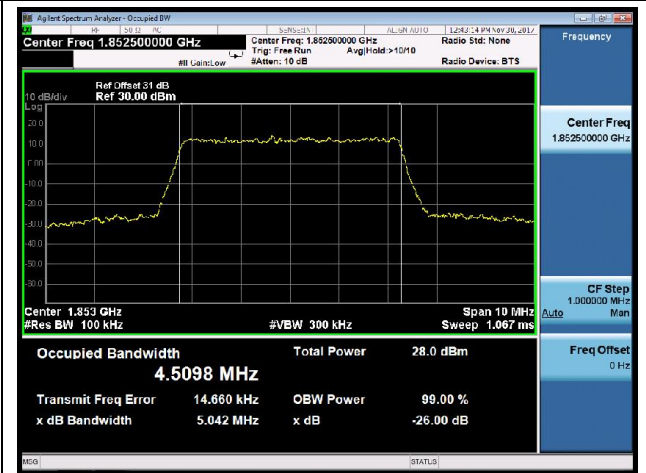

Mid. CH / 5MHz / QPSK

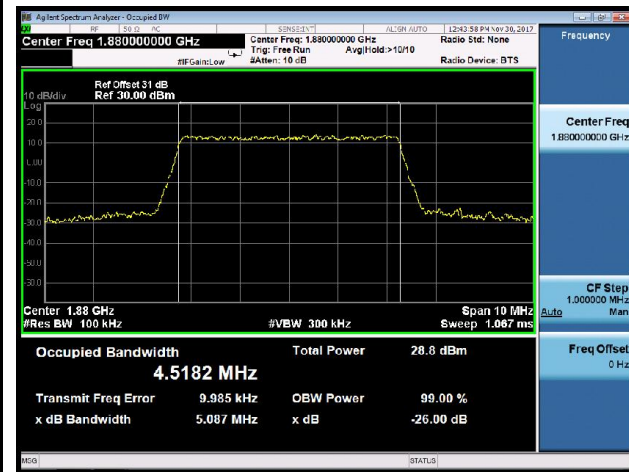

Mid. CH / 5MHz / 16-QAM

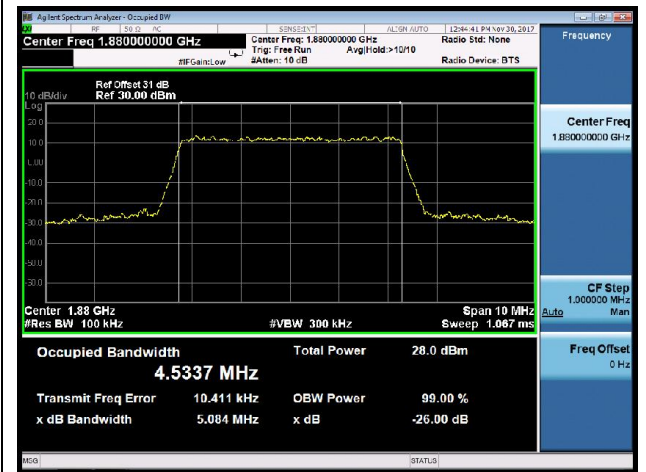

High CH / 5MHz / QPSK

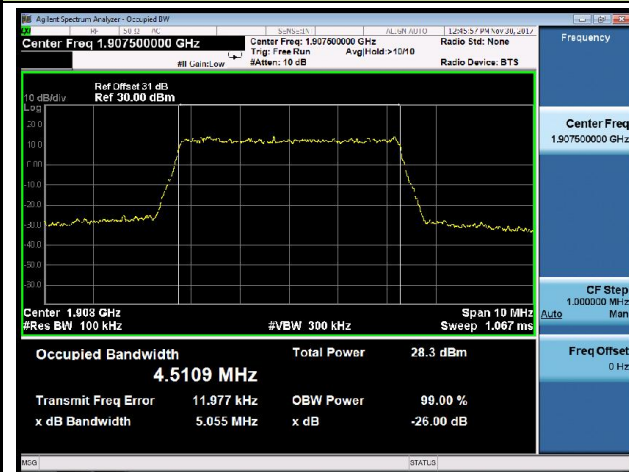

High CH / 5MHz / 16-QAM

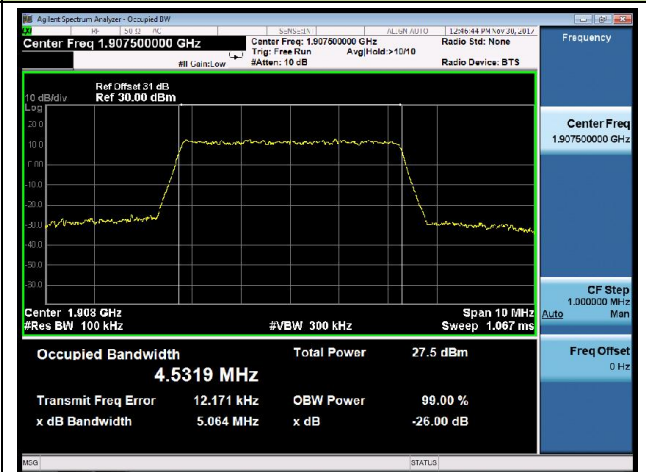

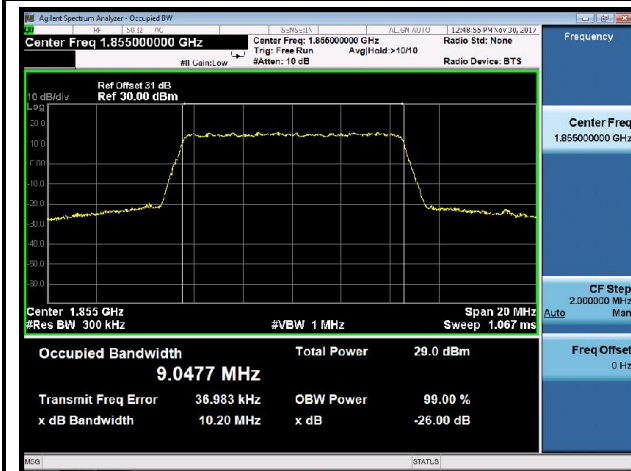
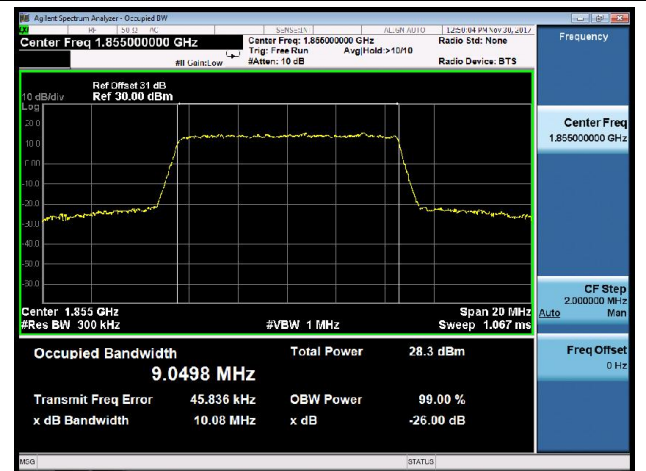
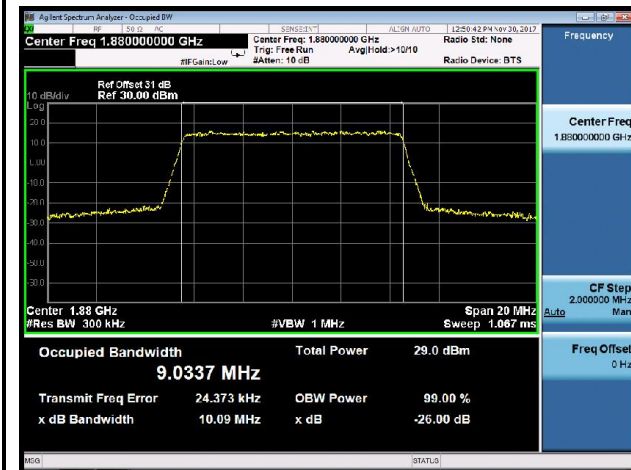
LTE Band 2 99% & 26dB Occupied Bandwidth
Low CH / 10MHz / QPSK

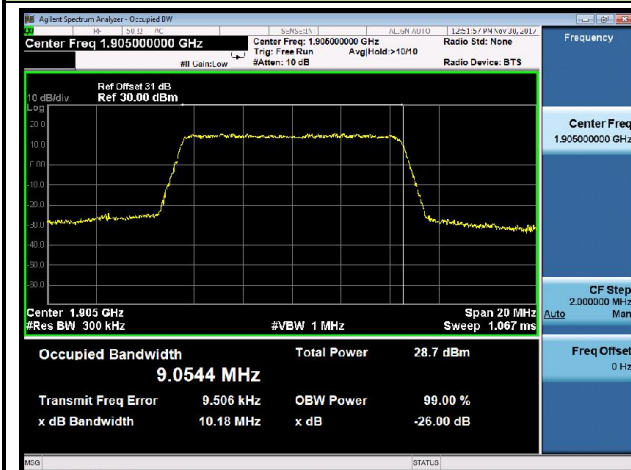
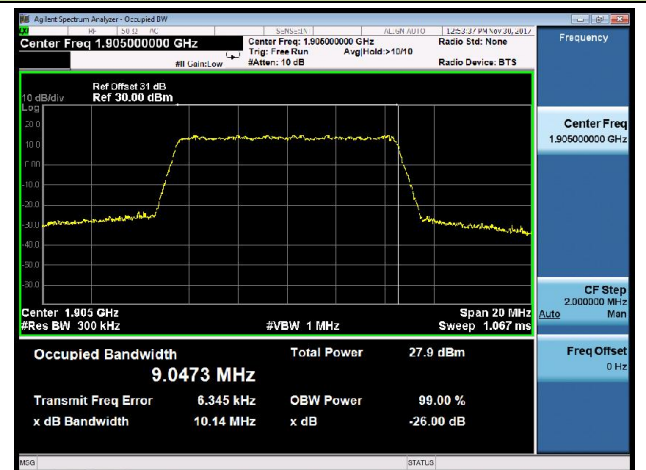
Low CH / 10MHz / 16-QAM

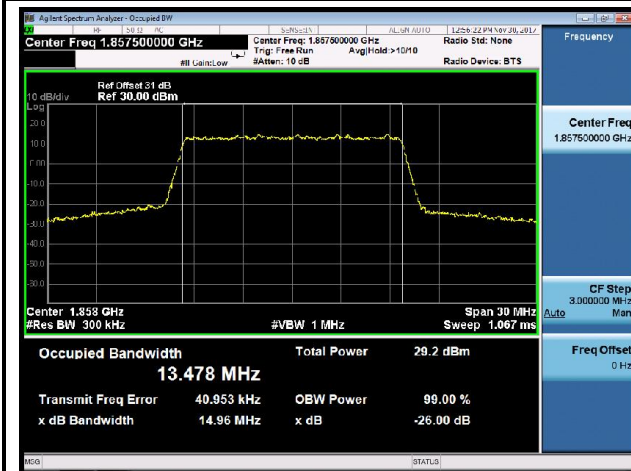
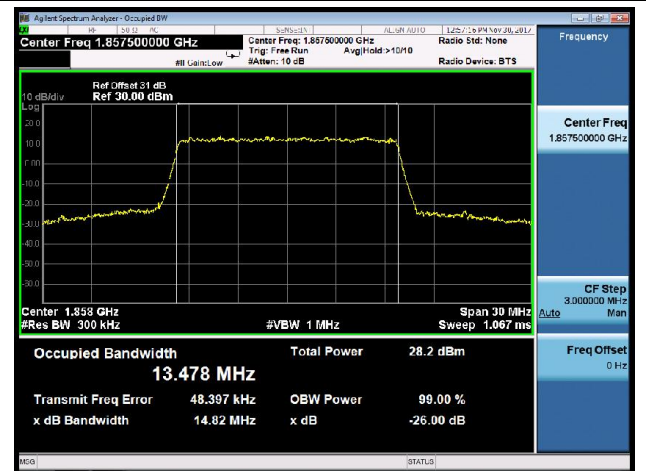
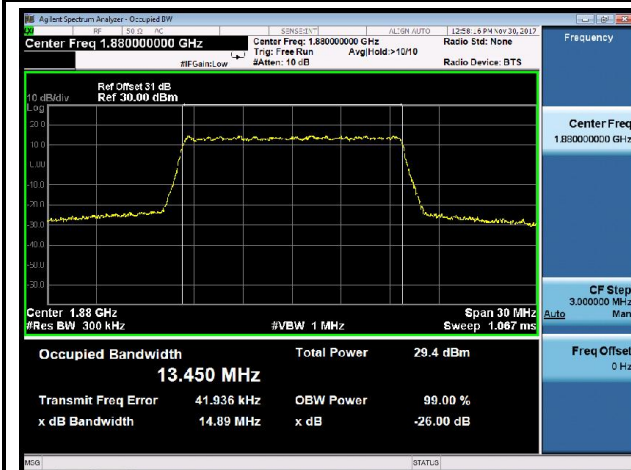
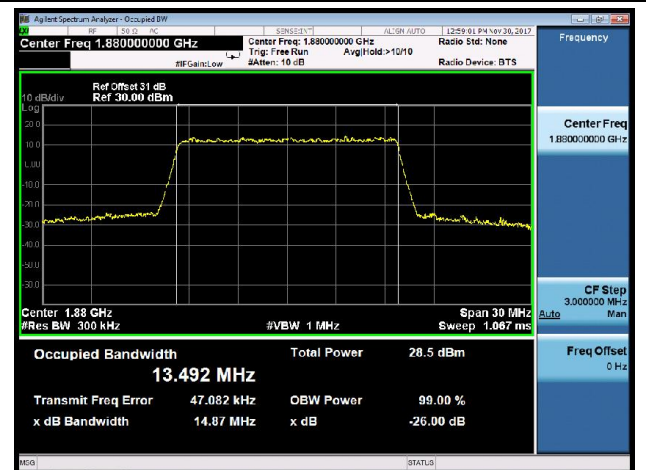
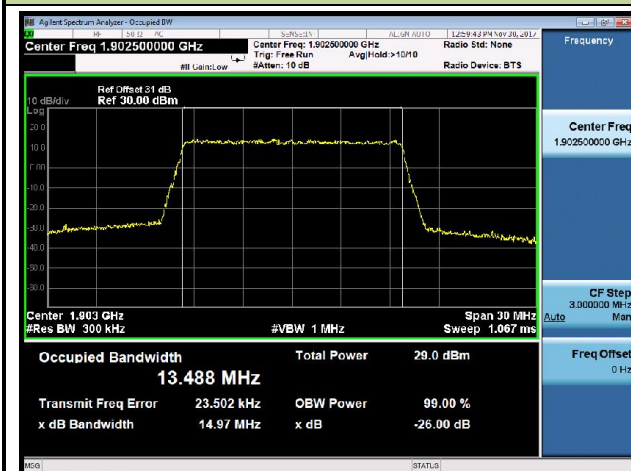
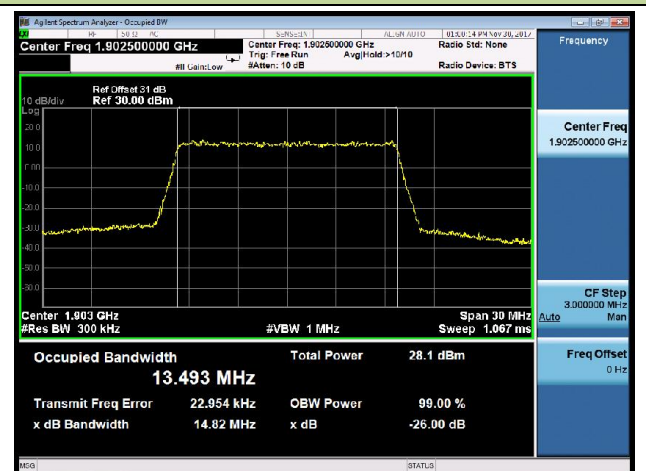
Mid. CH / 10MHz / QPSK

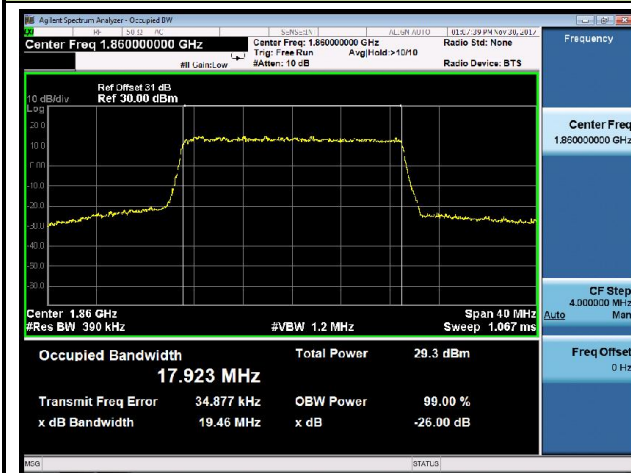
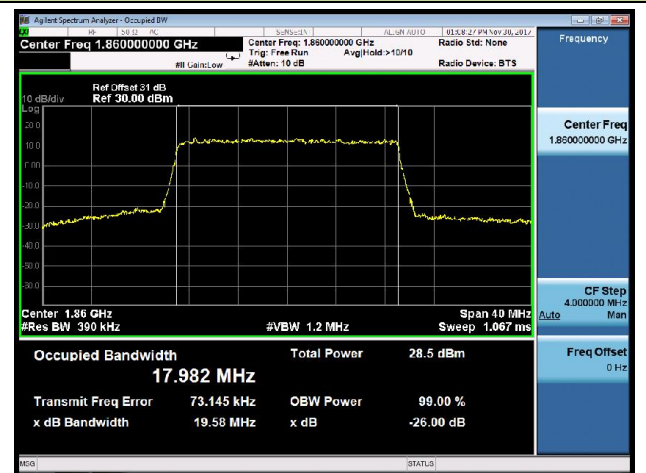
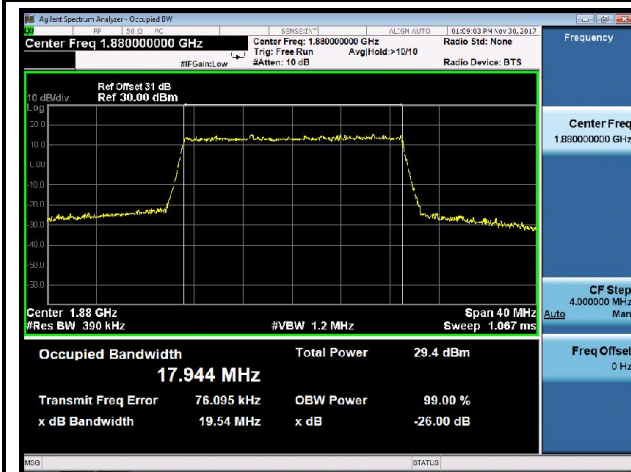
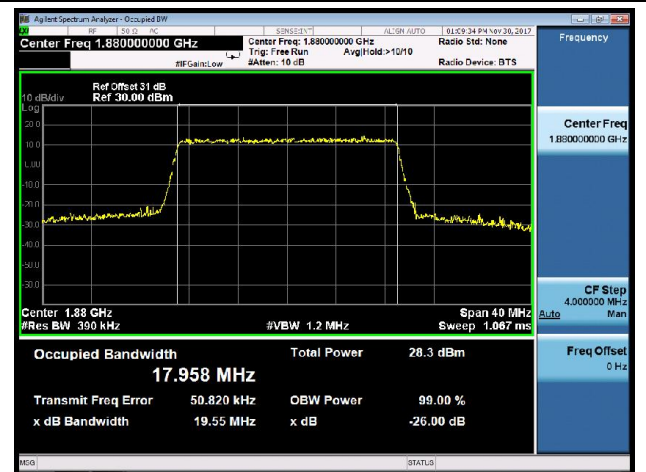
Mid. CH / 10MHz / 16-QAM

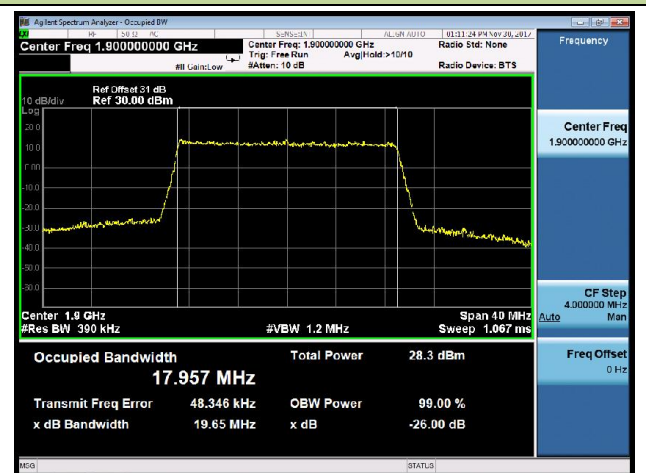
High CH / 10MHz / QPSK

High CH / 10MHz / 16-QAM

LTE Band 2 99% & 26dB Occupied Bandwidth
Low CH / 15MHz / QPSK

Low CH / 15MHz / 16-QAM

Mid. CH / 15MHz / QPSK

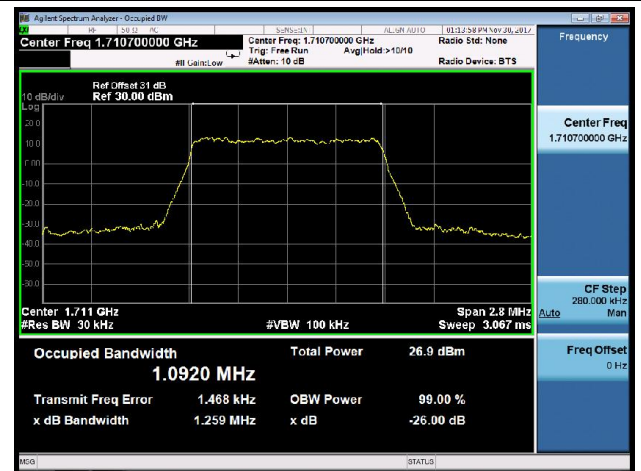
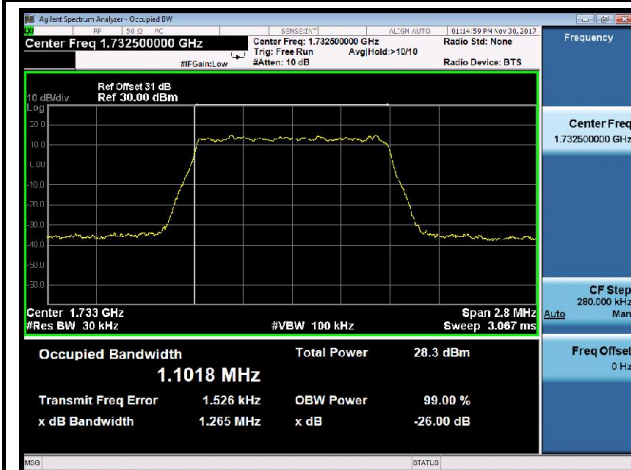
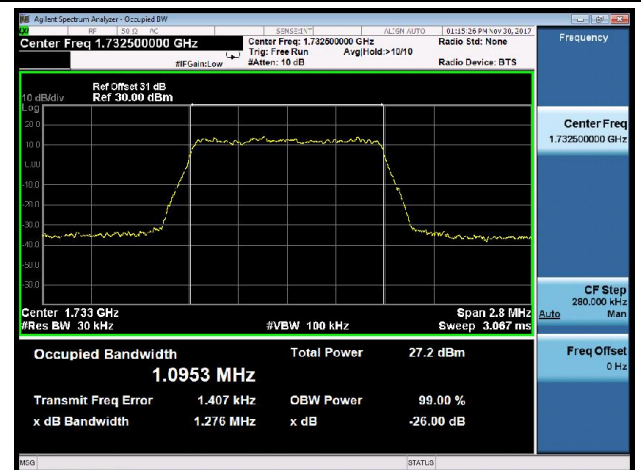
Mid. CH / 15MHz / 16-QAM

High CH / 15MHz / QPSK

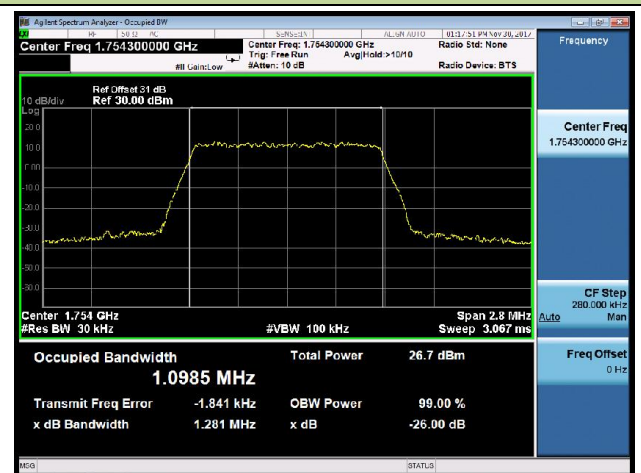
High CH / 15MHz / 16-QAM

LTE Band 2 99% & 26dB Occupied Bandwidth
Low CH / 20MHz / QPSK

Low CH / 20MHz / 16-QAM

Mid. CH / 20MHz / QPSK

Mid. CH / 20MHz / 16-QAM

High CH / 20MHz / QPSK

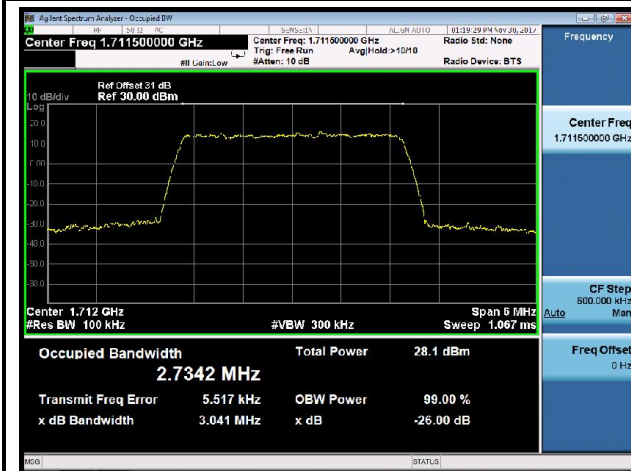
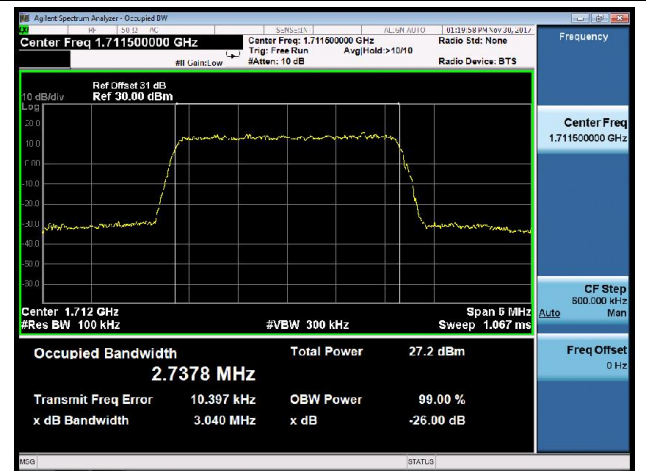
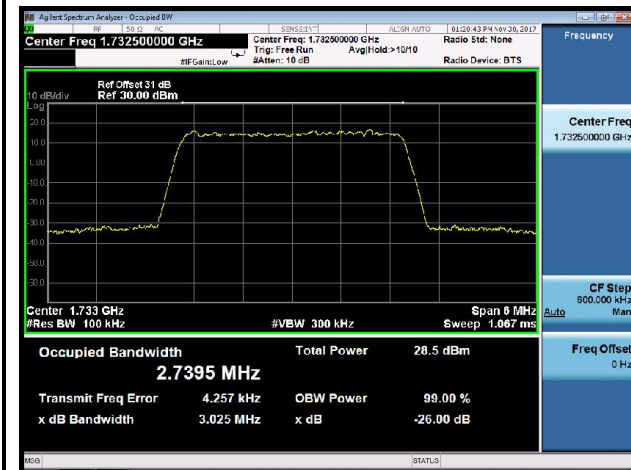
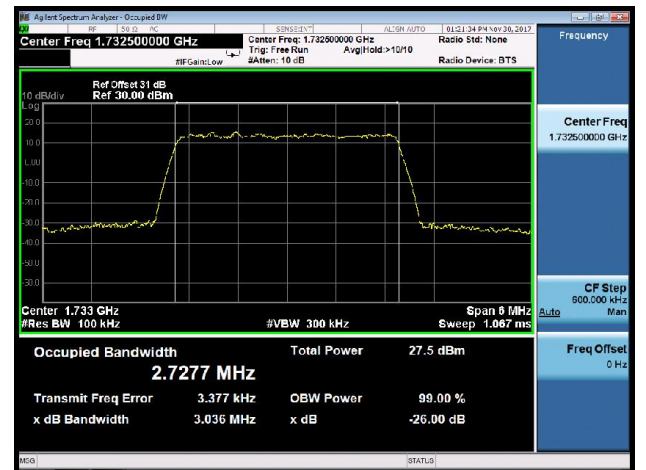
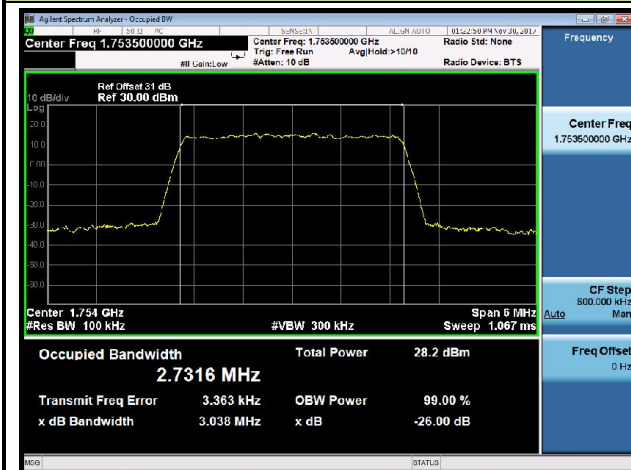
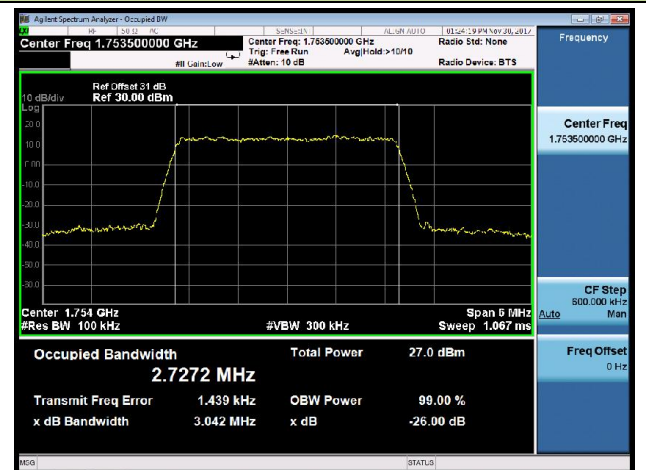
High CH / 20MHz / 16-QAM

LTE Band 4 99% & 26dB Occupied Bandwidth
Low CH / 1.4MHz / QPSK

Low CH / 1.4MHz / 16-QAM

Mid. CH / 1.4MHz / QPSK

Mid. CH / 1.4MHz / 16-QAM

High CH / 1.4MHz / QPSK

High CH / 1.4MHz / 16-QAM

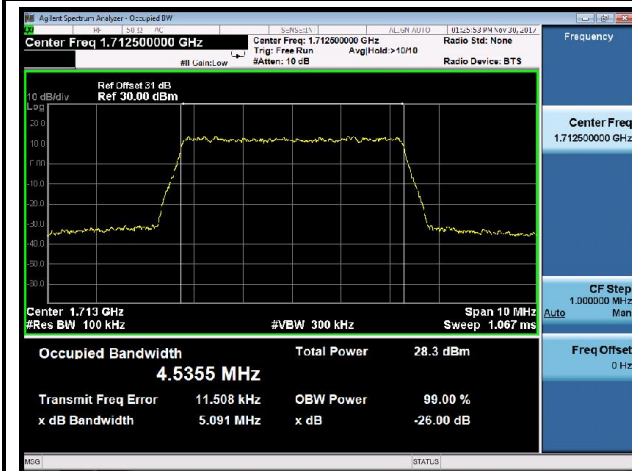
LTE Band 4 99% & 26dB Occupied Bandwidth
Low CH / 3MHz / QPSK

Low CH / 3MHz / 16-QAM

Mid. CH / 3MHz / QPSK

Mid. CH / 3MHz / 16-QAM

High CH / 3MHz / QPSK

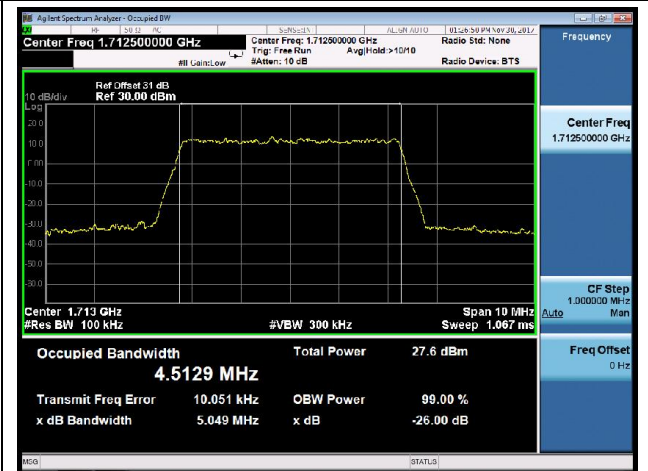
High CH / 3MHz / 16-QAM

LTE Band 4 99% & 26dB Occupied Bandwidth

Low CH / 5MHz / QPSK



Low CH / 5MHz / 16-QAM



Mid. CH / 5MHz / QPSK

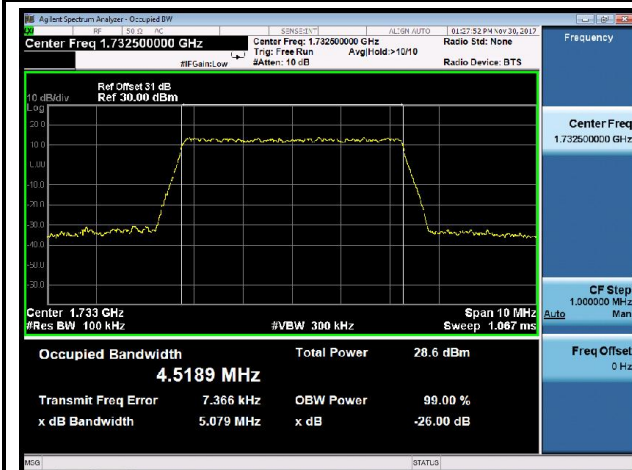

Mid. CH / 5MHz / 16-QAM

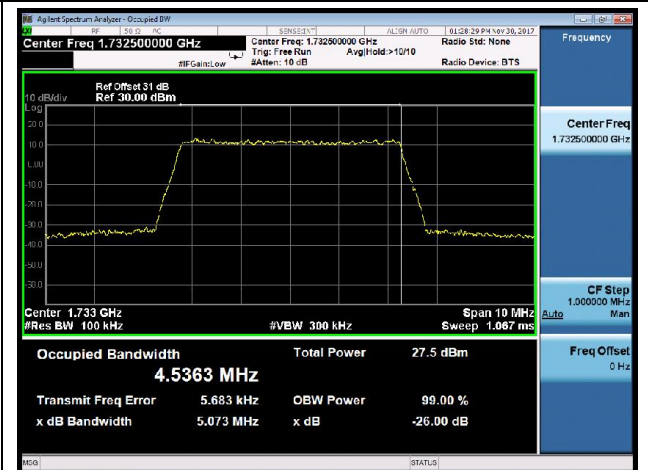

High CH / 5MHz / QPSK

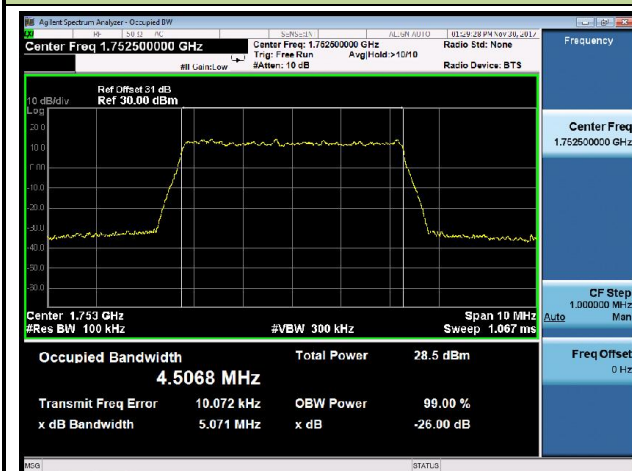

High CH / 5MHz / 16-QAM

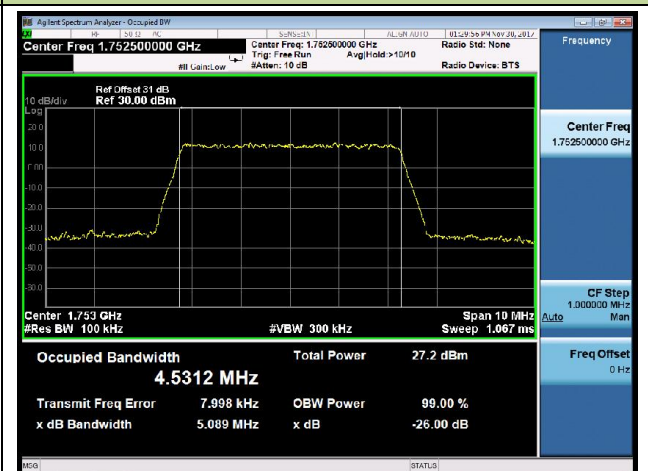

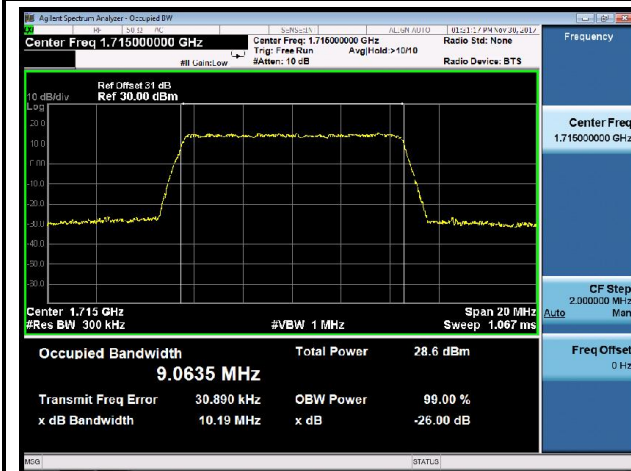
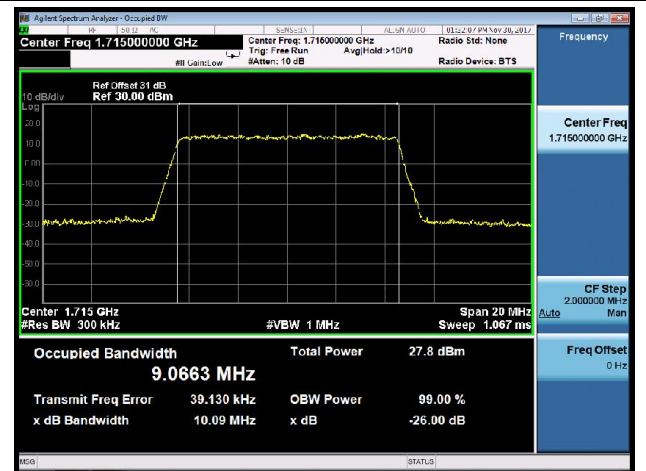
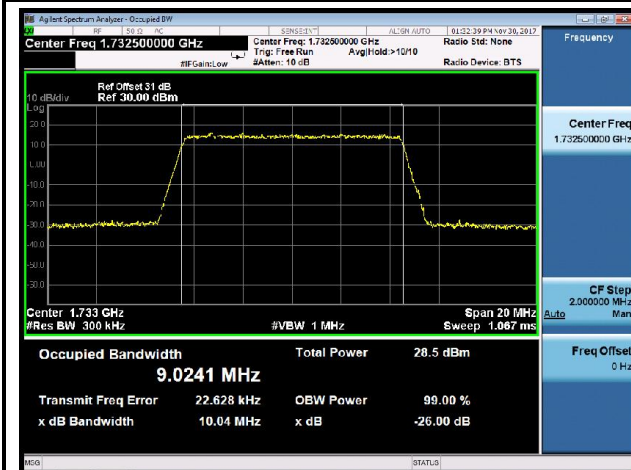
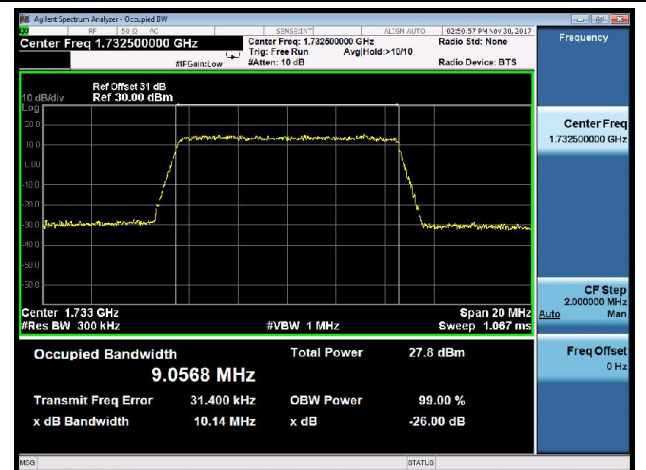
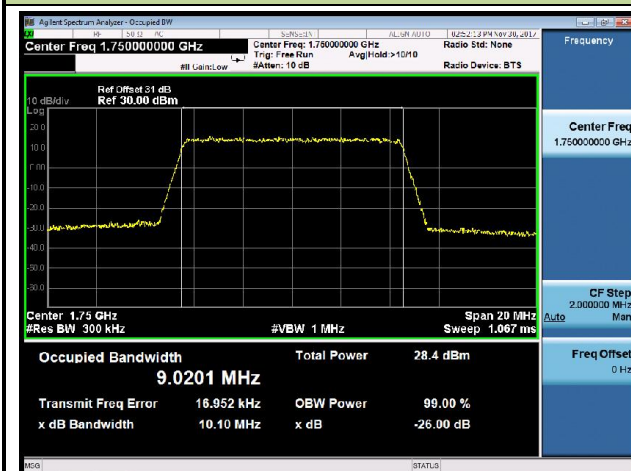
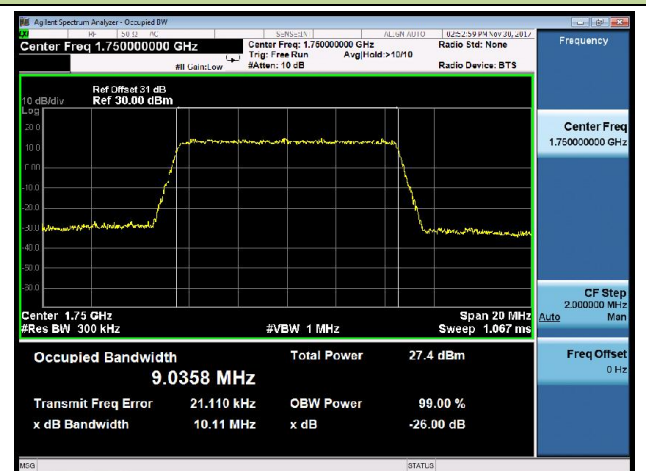
LTE Band 4 99% & 26dB Occupied Bandwidth
Low CH / 10MHz / QPSK

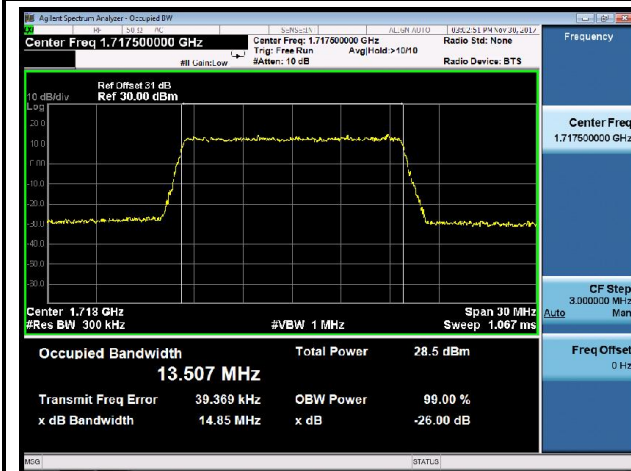
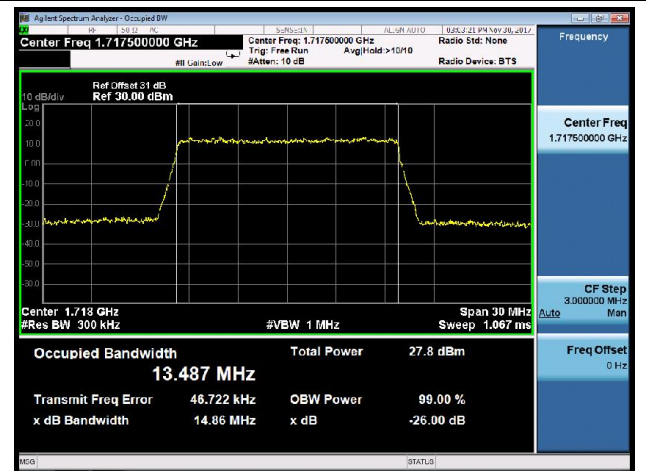
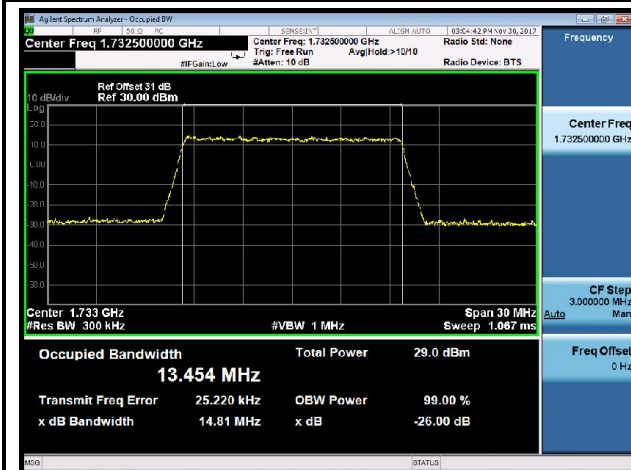
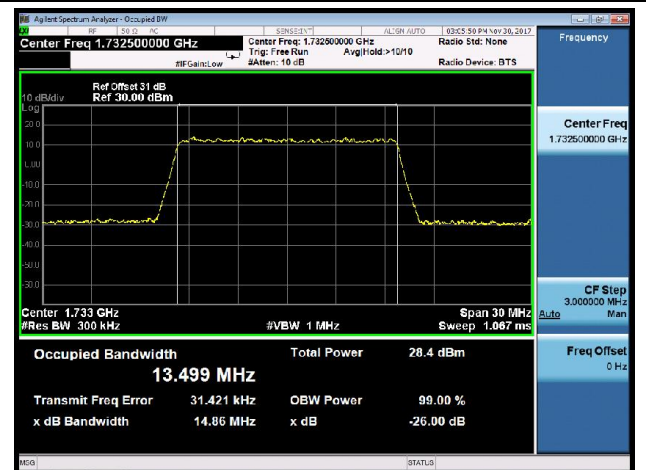
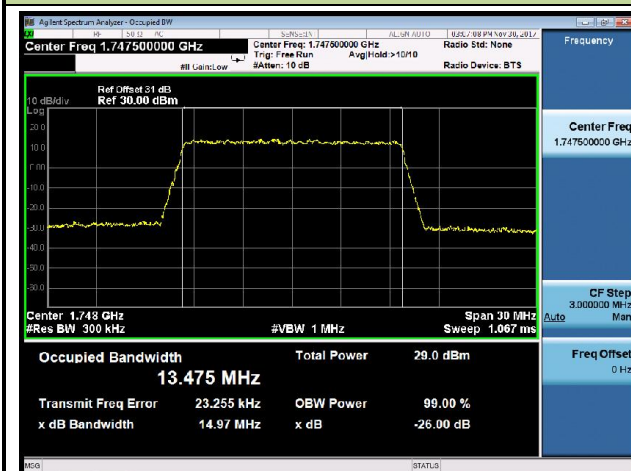
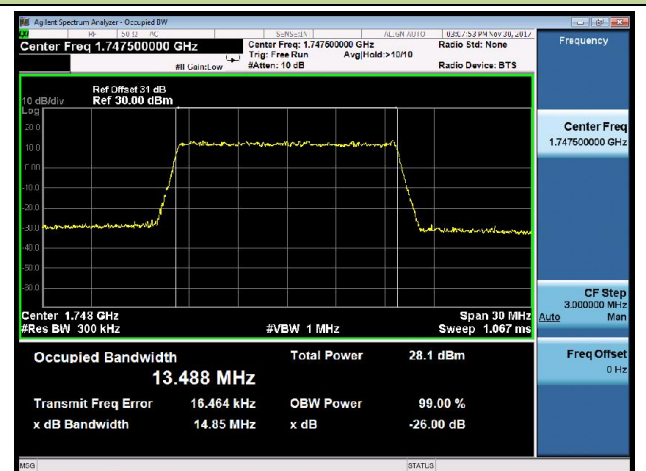
Low CH / 10MHz / 16-QAM

Mid. CH / 10MHz / QPSK

Mid. CH / 10MHz / 16-QAM

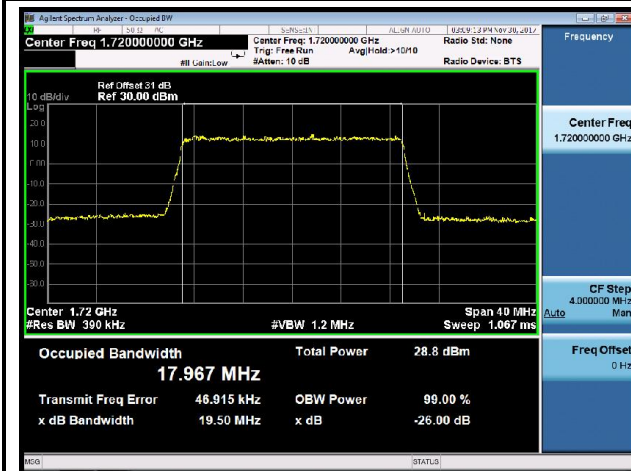
High CH / 10MHz / QPSK

High CH / 10MHz / 16-QAM

LTE Band 4 99% & 26dB Occupied Bandwidth
Low CH / 15MHz / QPSK

Low CH / 15MHz / 16-QAM

Mid. CH / 15MHz / QPSK

Mid. CH / 15MHz / 16-QAM

High CH / 15MHz / QPSK

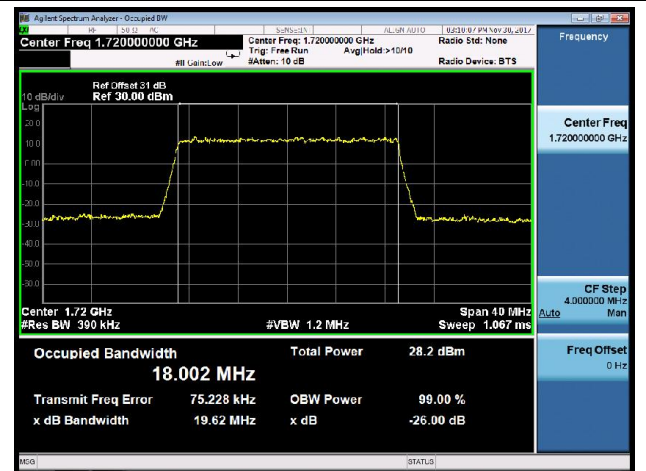
High CH / 15MHz / 16-QAM

LTE Band 4 99% & 26dB Occupied Bandwidth

Low CH / 20MHz / QPSK



Low CH / 20MHz / 16-QAM



Mid. CH / 20MHz / QPSK

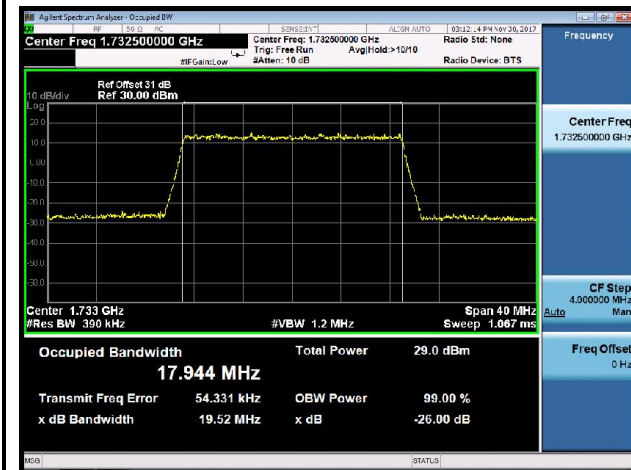

Mid. CH / 20MHz / 16-QAM

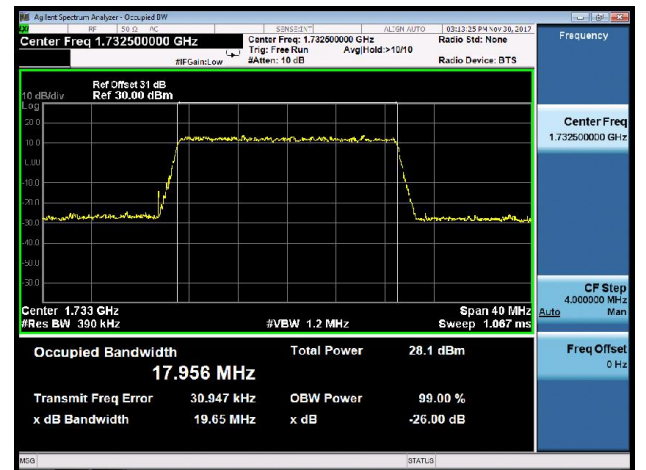

High CH / 20MHz / QPSK

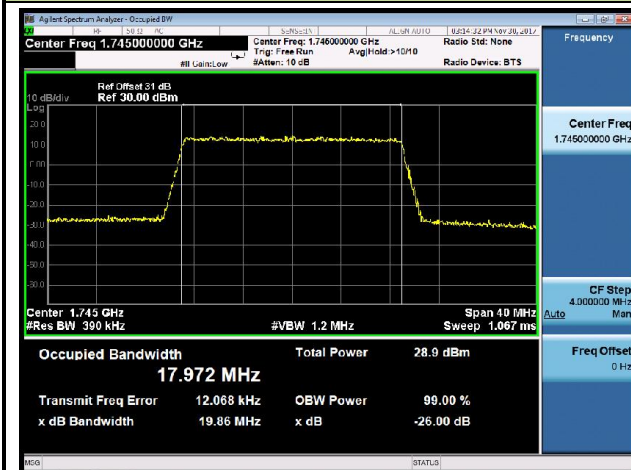

High CH / 20MHz / 16-QAM

