

Channel 11 (2462MHz)

100kHz PSD Reference Level

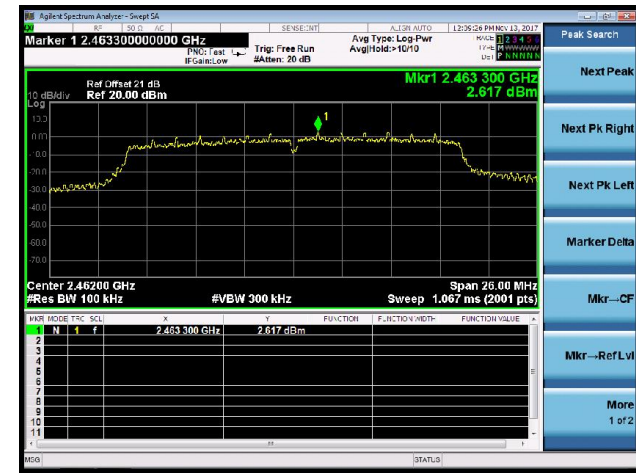

High Band Edge



Spurious Emission

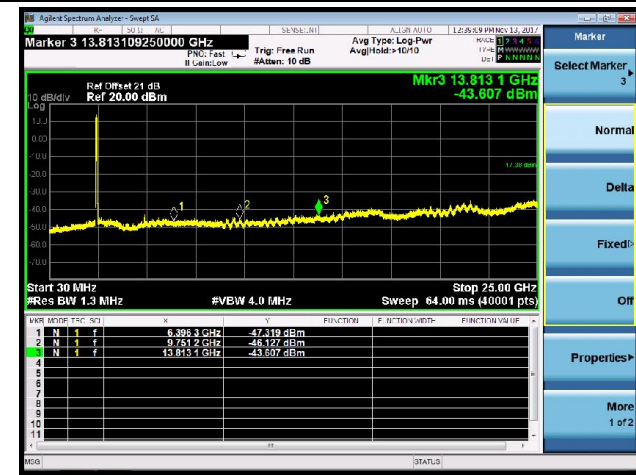

802.11n-HT40 Out-of-Band Emissions

Channel 01 (2422MHz)

100kHz PSD Reference Level



Low Band Edge

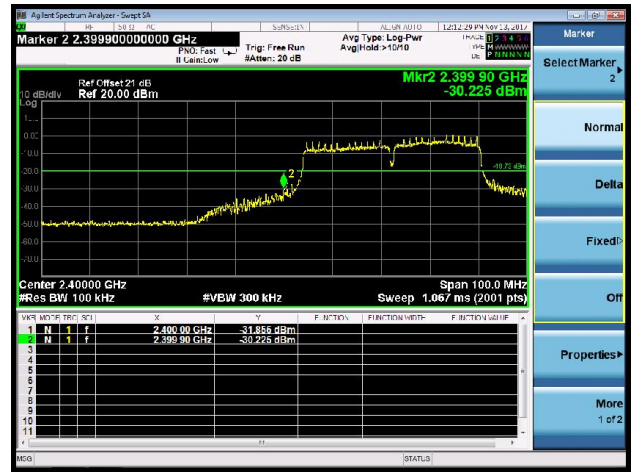

Spurious Emission

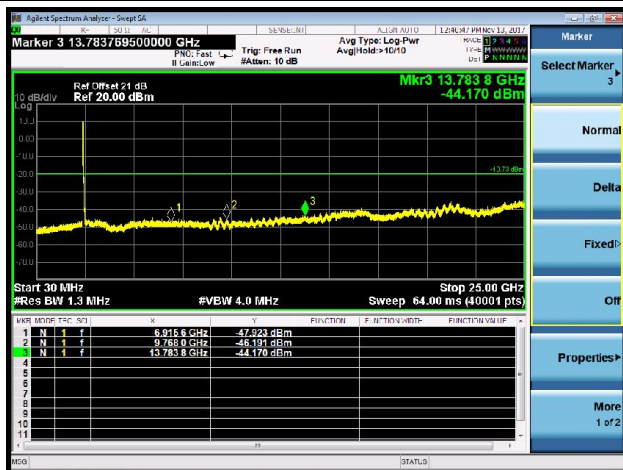

Channel 06 (2437MHz)

100kHz PSD Reference Level



Spurious Emission

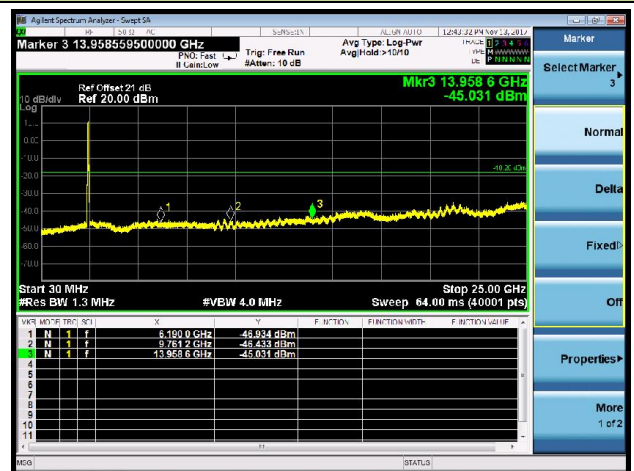

Channel 11 (2452MHz)

100kHz PSD Reference Level



High Band Edge



Spurious Emission

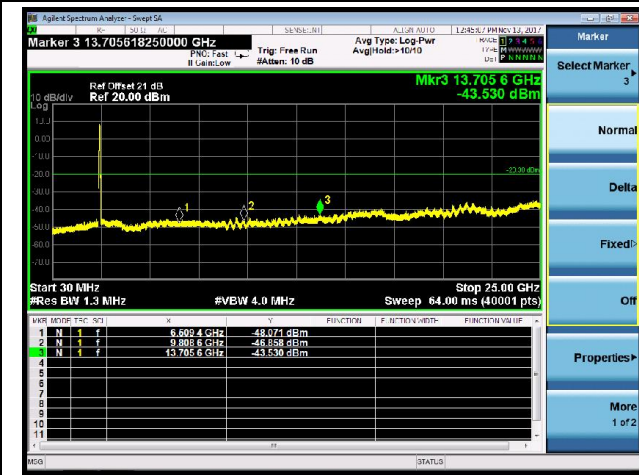

7.6. Radiated Spurious Emission Measurement

7.6.1. Test Limit

All out of band emissions appearing in a restricted band as specified in Section 15.205 of the Title 47 CFR must not exceed the limits shown in Table per Section 15.209.

FCC Part 15 Subpart C Paragraph 15.209		
Frequency [MHz]	Field Strength [uV/m]	Measured Distance [Meters]
0.009 - 0.490	2400/F (kHz)	300
0.490 - 1.705	24000/F (kHz)	30
1.705 - 30	30	30
30 - 88	100	3
88 - 216	150	3
216 - 960	200	3
Above 960	500	3

7.6.2. Test Procedure Used

KDB 558074 D01v04 – Section 12.2.3 (quasi-peak measurements)

KDB 558074 D01v04 – Section 12.2.4 (peak power measurements)

KDB 558074 D01v04 – Section 12.2.5 (average power measurements)

7.6.3. Test Setting

Peak Field Strength Measurements

1. Analyzer center frequency was set to the frequency of the radiated spurious emission of interest
2. RBW = as specified in Table 1
3. VBW = 3MHz
4. Detector = peak
5. Sweep time = auto couple
6. Trace mode = max hold
7. Trace was allowed to stabilize

Table 1 - RBW as a function of frequency

Frequency	RBW
9 ~ 150 kHz	200 ~ 300 Hz
0.15 ~ 30 MHz	9 ~ 10 kHz
30 ~ 1000 MHz	100 ~ 120 kHz
> 1000 MHz	1 MHz

Average Field Strength Measurements

1. Analyzer center frequency was set to the frequency of the radiated spurious emission of interest
2. RBW = 1MHz
3. VBW \geq 1/T
4. De As an alternative, the instrument may be set to linear detector mode. Ensure that video filtering is applied in linear voltage domain (rather than in a log or dB domain). Some instruments require linear display mode in order to accomplish this. Others have a setting for Average-VBW Type, which can be set to "Voltage" regardless of the display mode
5. Detector = Peak
6. Sweep time = auto
7. Trace mode = max hold
8. Allow max hold to run for at least 50 times (1/duty cycle) traces

7.6.4. Test Setup

9kHz ~ 30MHz Test Setup:

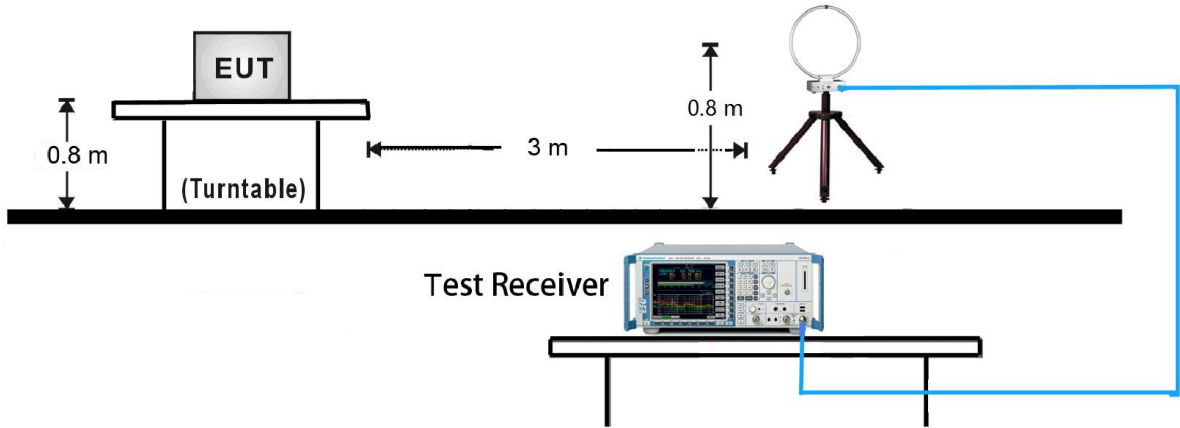

30MHz ~ 1GHz Test Setup:

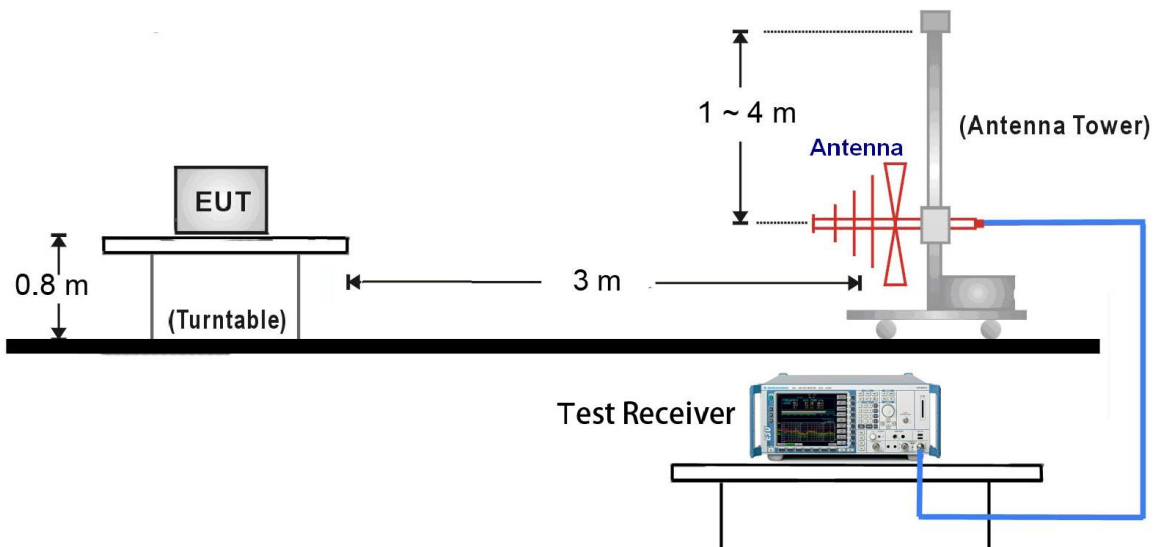

1GHz ~ 18GHz Test Setup:

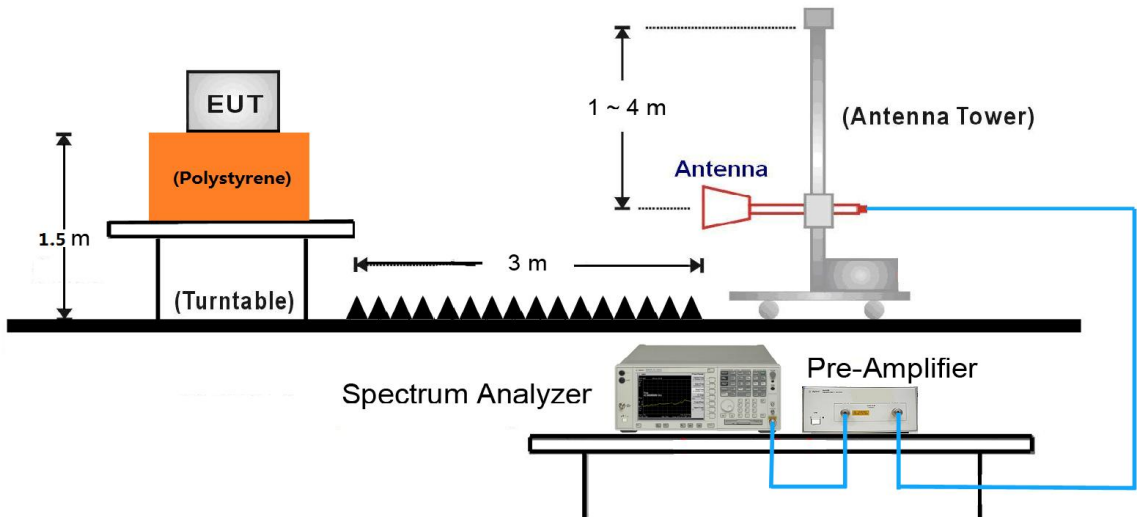

18GHz ~25GHz Test Setup:

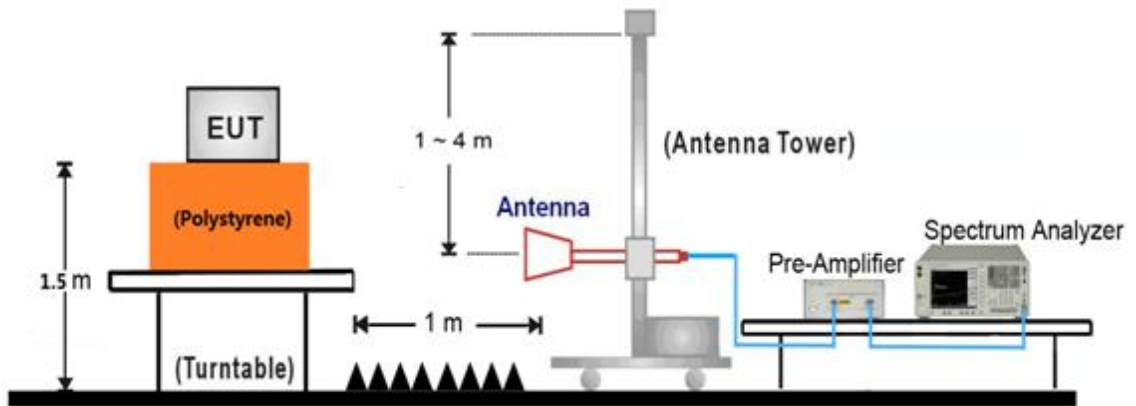

7.6.5. Test Result

Product	Mobile Data Terminal	Temperature	26°C
Test Engineer	Will Yan	Relative Humidity	56%
Test Site	AC1	Test Date	2017/11/17
Test Mode:	802.11b	Test Channel:	01
Remark:	1. Average measurement was not performed if peak level lower than average limit. 2. Other frequency was 20dB below limit line within 1-18GHz, there is not show in the report.		

Mark	Frequency (MHz)	Reading Level (dBμV)	Factor (dB)	Measure Level (dBμV/m)	Limit (dBμV/m)	Margin (dB)	Detector	Polarization
	4825.0	39.9	2.7	42.6	74.0	-31.4	Peak	Horizontal
	9321.5	34.3	10.4	44.7	74.0	-29.3	Peak	Horizontal
*	10528.5	33.9	12.5	46.4	80.2	-33.8	Peak	Horizontal
*	13529.0	34.6	13.8	48.4	80.2	-31.8	Peak	Horizontal
	4825.0	40.3	2.7	43.0	74.0	-31.0	Peak	Vertical
	8174.0	34.5	8.4	42.9	74.0	-31.1	Peak	Vertical
*	10477.5	34.6	12.2	46.8	80.2	-33.4	Peak	Vertical
*	13673.5	34.8	13.9	48.7	80.2	-31.5	Peak	Vertical

Note 1: "*" is not in restricted band, its limit is 30dBc of the fundamental emission level (100.2dBμV/m) or 15.209 which is higher.

Note 2: Measure Level (dBμV/m) = Reading Level (dBμV) + Factor (dB)

Factor (dB) = Cable Loss (dB) + Antenna Factor (dB/m) - Pre_Amplifier Gain (dB)

Product	Mobile Data Terminal	Temperature	26°C
Test Engineer	Will Yan	Relative Humidity	56%
Test Site	AC1	Test Date	2017/11/17
Test Mode:	802.11b	Test Channel:	06
Remark:	1. Average measurement was not performed if peak level lower than average limit. 2. Other frequency was 20dB below limit line within 1-18GHz, there is not show in the report.		

Mark	Frequency (MHz)	Reading Level (dBμV)	Factor (dB)	Measure Level (dBμV/m)	Limit (dBμV/m)	Margin (dB)	Detector	Polarization
	4842.0	35.7	2.7	38.4	74.0	-35.6	Peak	Horizontal
	8259.0	35.2	8.1	43.3	74.0	-30.7	Peak	Horizontal
*	10494.5	34.7	12.4	47.1	80.1	-33.0	Peak	Horizontal
*	13648.0	34.8	13.9	48.7	80.1	-31.4	Peak	Horizontal
	4799.5	35.0	2.7	37.7	74.0	-36.3	Peak	Vertical
	9304.5	33.9	10.4	44.3	74.0	-29.7	Peak	Vertical
*	10418.0	35.3	12.2	47.5	80.1	-32.6	Peak	Vertical
*	13639.5	35.2	13.9	49.1	80.1	-31.0	Peak	Vertical

Note 1: "*" is not in restricted band, its limit is 30dBc of the fundamental emission level (100.1dBμV/m) or 15.209 which is higher.

Note 2: Measure Level (dBμV/m) = Reading Level (dBμV) + Factor (dB)

Factor (dB) = Cable Loss (dB) + Antenna Factor (dB/m) - Pre_Amplifier Gain (dB)

Product	Mobile Data Terminal	Temperature	26°C
Test Engineer	Will Yan	Relative Humidity	56%
Test Site	AC1	Test Date	2017/11/17
Test Mode:	802.11b	Test Channel:	11
Remark:	1. Average measurement was not performed if peak level lower than average limit. 2. Other frequency was 20dB below limit line within 1-18GHz, there is not show in the report.		

Mark	Frequency (MHz)	Reading Level (dBμV)	Factor (dB)	Measure Level (dBμV/m)	Limit (dBμV/m)	Margin (dB)	Detector	Polarization
	4927.0	41.4	2.8	44.2	74.0	-29.8	Peak	Horizontal
	8140.0	35.5	8.5	44.0	74.0	-30.0	Peak	Horizontal
*	10503.0	35.0	12.4	47.4	80.6	-33.2	Peak	Horizontal
*	13648.0	35.0	13.9	48.9	80.6	-31.7	Peak	Horizontal
	4927.0	43.9	2.8	46.7	74.0	-27.3	Peak	Vertical
	8454.5	34.8	8.2	43.0	74.0	-31.0	Peak	Vertical
*	10418.0	34.6	12.2	46.8	80.6	-33.8	Peak	Vertical
*	13648.0	34.9	13.9	48.8	80.6	-31.8	Peak	Vertical

Note 1: "*" is not in restricted band, its limit is 30dBc of the fundamental emission level (100.6dBμV/m) or 15.209 which is higher.

Note 2: Measure Level (dBμV/m) = Reading Level (dBμV) + Factor (dB)

Factor (dB) = Cable Loss (dB) + Antenna Factor (dB/m) - Pre_Amplifier Gain (dB)

Product	Mobile Data Terminal	Temperature	26°C
Test Engineer	Will Yan	Relative Humidity	56%
Test Site	AC1	Test Date	2017/11/17
Test Mode:	802.11g	Test Channel:	01
Remark:	1. Average measurement was not performed if peak level lower than average limit. 2. Other frequency was 20dB below limit line within 1-18GHz, there is not show in the report.		

Mark	Frequency (MHz)	Reading Level (dBμV)	Factor (dB)	Measure Level (dBμV/m)	Limit (dBμV/m)	Margin (dB)	Detector	Polarization
	4782.5	35.5	2.7	38.2	74.0	-35.8	Peak	Horizontal
	9177.0	35.5	10.0	45.5	74.0	-28.5	Peak	Horizontal
*	10494.5	34.3	12.4	46.7	78.0	-31.3	Peak	Horizontal
*	13690.5	34.7	14.0	48.7	78.0	-29.3	Peak	Horizontal
	4825.0	37.1	2.7	39.8	74.0	-34.2	Peak	Vertical
	9415.0	33.8	10.6	44.4	74.0	-29.6	Peak	Vertical
*	10579.5	34.2	12.4	46.6	78.0	-31.4	Peak	Vertical
*	13563.0	34.0	13.9	47.9	78.0	-30.1	Peak	Vertical

Note 1: "*" is not in restricted band, its limit is 30dBc of the fundamental emission level (98.0dBμV/m) or 15.209 which is higher.

Note 2: Measure Level (dBμV/m) = Reading Level (dBμV) + Factor (dB)

Factor (dB) = Cable Loss (dB) + Antenna Factor (dB/m) - Pre_Amplifier Gain (dB)

Product	Mobile Data Terminal	Temperature	26°C
Test Engineer	Will Yan	Relative Humidity	56%
Test Site	AC1	Test Date	2017/11/17
Test Mode:	802.11g	Test Channel:	06
Remark:	1. Average measurement was not performed if peak level lower than average limit. 2. Other frequency was 20dB below limit line within 1-18GHz, there is not show in the report.		

Mark	Frequency (MHz)	Reading Level (dBμV)	Factor (dB)	Measure Level (dBμV/m)	Limit (dBμV/m)	Margin (dB)	Detector	Polarization
	4799.5	35.6	2.7	38.3	74.0	-35.7	Peak	Horizontal
	9347.0	34.7	10.5	45.2	74.0	-28.8	Peak	Horizontal
*	10520.0	34.1	12.4	46.5	80.5	-34.0	Peak	Horizontal
*	13648.0	33.9	13.9	47.8	80.5	-32.7	Peak	Horizontal
	4935.5	36.6	2.8	39.4	74.0	-34.6	Peak	Vertical
	9347.0	34.4	10.5	44.9	74.0	-29.1	Peak	Vertical
*	10511.5	34.0	12.4	46.4	80.5	-34.1	Peak	Vertical
*	13962.5	35.9	14.7	50.6	80.5	-29.9	Peak	Vertical

Note 1: "*" is not in restricted band, its limit is 30dBc of the fundamental emission level (100.5dBμV/m) or 15.209 which is higher.

Note 2: Measure Level (dBμV/m) = Reading Level (dBμV) + Factor (dB)

Factor (dB) = Cable Loss (dB) + Antenna Factor (dB/m) - Pre_Amplifier Gain (dB)

Product	Mobile Data Terminal	Temperature	26°C
Test Engineer	Will Yan	Relative Humidity	56%
Test Site	AC1	Test Date	2017/11/17
Test Mode:	802.11g	Test Channel:	11
Remark:	1. Average measurement was not performed if peak level lower than average limit. 2. Other frequency was 20dB below limit line within 1-18GHz, there is not show in the report.		

Mark	Frequency (MHz)	Reading Level (dBμV)	Factor (dB)	Measure Level (dBμV/m)	Limit (dBμV/m)	Margin (dB)	Detector	Polarization
	4918.5	35.0	2.8	37.8	74.0	-36.2	Peak	Horizontal
	8318.5	35.0	8.0	43.0	74.0	-31.0	Peak	Horizontal
*	10528.5	34.0	12.5	46.5	81.0	-34.5	Peak	Horizontal
*	13733.0	34.3	14.2	48.5	81.0	-32.5	Peak	Horizontal
	4927.0	36.8	2.8	39.6	74.0	-34.4	Peak	Vertical
	9338.5	33.8	10.4	44.2	74.0	-29.8	Peak	Vertical
*	10554.0	34.0	12.5	46.5	81.0	-34.5	Peak	Vertical
*	13665.0	34.4	13.9	48.3	81.0	-32.7	Peak	Vertical

Note 1: "*" is not in restricted band, its limit is 30dBc of the fundamental emission level (101.0dBμV/m) or 15.209 which is higher.

Note 2: Measure Level (dBμV/m) = Reading Level (dBμV) + Factor (dB)

Factor (dB) = Cable Loss (dB) + Antenna Factor (dB/m) - Pre_Amplifier Gain (dB)

Product	Mobile Data Terminal	Temperature	26°C
Test Engineer	Will Yan	Relative Humidity	56%
Test Site	AC1	Test Date	2017/11/17
Test Mode:	802.11n-HT20	Test Channel:	01
Remark:	1. Average measurement was not performed if peak level lower than average limit. 2. Other frequency was 20dB below limit line within 1-18GHz, there is not show in the report.		

Mark	Frequency (MHz)	Reading Level (dBμV)	Factor (dB)	Measure Level (dBμV/m)	Limit (dBμV/m)	Margin (dB)	Detector	Polarization
	4816.5	35.9	2.7	38.6	74.0	-35.4	Peak	Horizontal
	9364.0	33.8	10.5	44.3	74.0	-29.7	Peak	Horizontal
*	10486.0	34.5	12.3	46.8	78.3	-31.5	Peak	Horizontal
*	13665.0	35.0	13.9	48.9	78.3	-29.4	Peak	Horizontal
	4825.0	35.6	2.7	38.3	74.0	-35.7	Peak	Vertical
	9457.5	33.7	10.5	44.2	74.0	-29.8	Peak	Vertical
*	10469.0	34.2	12.1	46.3	78.3	-32.0	Peak	Vertical
*	13843.5	34.0	14.5	48.5	78.3	-29.8	Peak	Vertical

Note 1: "*" is not in restricted band, its limit is 30dBc of the fundamental emission level (98.3dBμV/m) or 15.209 which is higher.

Note 2: Measure Level (dBμV/m) = Reading Level (dBμV) + Factor (dB)

Factor (dB) = Cable Loss (dB) + Antenna Factor (dB/m) - Pre_Amplifier Gain (dB)

Product	Mobile Data Terminal	Temperature	26°C
Test Engineer	Will Yan	Relative Humidity	56%
Test Site	AC1	Test Date	2017/11/17
Test Mode:	802.11n-HT20	Test Channel:	06
Remark:	1. Average measurement was not performed if peak level lower than average limit. 2. Other frequency was 20dB below limit line within 1-18GHz, there is not show in the report.		

Mark	Frequency (MHz)	Reading Level (dBμV)	Factor (dB)	Measure Level (dBμV/m)	Limit (dBμV/m)	Margin (dB)	Detector	Polarization
	4833.5	35.0	2.7	37.7	74.0	-36.3	Peak	Horizontal
	9381.0	34.4	10.5	44.9	74.0	-29.1	Peak	Horizontal
*	10520.0	33.7	12.4	46.1	79.1	-33.0	Peak	Horizontal
*	13945.5	34.0	14.7	48.7	79.1	-30.4	Peak	Horizontal
	4833.5	35.9	2.7	38.6	74.0	-35.4	Peak	Vertical
	8327.0	34.5	8.0	42.5	74.0	-31.5	Peak	Vertical
*	10367.0	34.2	12.2	46.4	79.1	-32.7	Peak	Vertical
*	13605.5	34.5	13.9	48.4	79.1	-30.7	Peak	Vertical

Note 1: "*" is not in restricted band, its limit is 30dBc of the fundamental emission level (99.1dBμV/m) or 15.209 which is higher.

Note 2: Measure Level (dBμV/m) = Reading Level (dBμV) + Factor (dB)

Factor (dB) = Cable Loss (dB) + Antenna Factor (dB/m) - Pre_Amplifier Gain (dB)

Product	Mobile Data Terminal	Temperature	26°C
Test Engineer	Will Yan	Relative Humidity	56%
Test Site	AC1	Test Date	2017/11/17
Test Mode:	802.11n-HT20	Test Channel:	11
Remark:	1. Average measurement was not performed if peak level lower than average limit. 2. Other frequency was 20dB below limit line within 1-18GHz, there is not show in the report.		

Mark	Frequency (MHz)	Reading Level (dBμV)	Factor (dB)	Measure Level (dBμV/m)	Limit (dBμV/m)	Margin (dB)	Detector	Polarization
	4697.5	34.5	2.3	36.8	74.0	-37.2	Peak	Horizontal
	8480.0	34.4	8.3	42.7	74.0	-31.3	Peak	Horizontal
*	10452.0	34.2	12.0	46.2	80.0	-33.8	Peak	Horizontal
*	13529.0	33.3	13.8	47.1	80.0	-32.9	Peak	Horizontal
	4774.0	34.6	2.6	37.2	74.0	-36.8	Peak	Vertical
	8165.5	35.8	8.4	44.2	74.0	-29.8	Peak	Vertical
*	10503.0	33.7	12.4	46.1	80.0	-33.9	Peak	Vertical
*	13954.0	34.9	14.7	49.6	80.0	-30.4	Peak	Vertical

Note 1: "*" is not in restricted band, its limit is 30dBc of the fundamental emission level (100.0dBμV/m) or 15.209 which is higher.

Note 2: Measure Level (dBμV/m) = Reading Level (dBμV) + Factor (dB)

Factor (dB) = Cable Loss (dB) + Antenna Factor (dB/m) - Pre_Amplifier Gain (dB)

Product	Mobile Data Terminal	Temperature	26°C
Test Engineer	Will Yan	Relative Humidity	56%
Test Site	AC1	Test Date	2017/11/17
Test Mode:	802.11n-HT40	Test Channel:	03
Remark:	1. Average measurement was not performed if peak level lower than average limit. 2. Other frequency was 20dB below limit line within 1-18GHz, there is not show in the report.		

Mark	Frequency (MHz)	Reading Level (dBμV)	Factor (dB)	Measure Level (dBμV/m)	Limit (dBμV/m)	Margin (dB)	Detector	Polarization
	4842.0	34.4	2.7	37.1	74.0	-36.9	Peak	Horizontal
	8165.5	34.3	8.4	42.7	74.0	-31.3	Peak	Horizontal
*	10503.0	33.7	12.4	46.1	78.4	-32.3	Peak	Horizontal
*	13741.5	34.3	14.2	48.5	78.4	-29.9	Peak	Horizontal
	4799.5	35.4	2.7	38.1	74.0	-35.9	Peak	Vertical
	8293.0	34.4	8.0	42.4	74.0	-31.6	Peak	Vertical
*	10477.5	33.9	12.2	46.1	78.4	-32.3	Peak	Vertical
*	13622.5	34.6	13.9	48.5	78.4	-29.9	Peak	Vertical

Note 1: "*" is not in restricted band, its limit is 30dBc of the fundamental emission level (98.4dBμV/m) or 15.209 which is higher.

Note 2: Measure Level (dBμV/m) = Reading Level (dBμV) + Factor (dB)

Factor (dB) = Cable Loss (dB) + Antenna Factor (dB/m) - Pre_Amplifier Gain (dB)

Product	Mobile Data Terminal	Temperature	26°C
Test Engineer	Will Yan	Relative Humidity	56%
Test Site	AC1	Test Date	2017/11/17
Test Mode:	802.11n-HT40	Test Channel:	06
Remark:	1. Average measurement was not performed if peak level lower than average limit. 2. Other frequency was 20dB below limit line within 1-18GHz, there is not show in the report.		

Mark	Frequency (MHz)	Reading Level (dBμV)	Factor (dB)	Measure Level (dBμV/m)	Limit (dBμV/m)	Margin (dB)	Detector	Polarization
	4859.0	34.8	2.7	37.5	74.0	-36.5	Peak	Horizontal
	8199.5	34.4	8.3	42.7	74.0	-31.3	Peak	Horizontal
*	10537.0	33.9	12.5	46.4	76.5	-30.1	Peak	Horizontal
*	13877.5	34.0	14.6	48.6	76.5	-27.9	Peak	Horizontal
	4884.5	35.9	2.7	38.6	74.0	-35.4	Peak	Vertical
	8471.5	35.6	8.2	43.8	74.0	-30.2	Peak	Vertical
*	10520.0	35.3	12.4	47.7	76.5	-28.8	Peak	Vertical
*	13631.0	34.2	13.9	48.1	76.5	-28.4	Peak	Vertical

Note 1: "*" is not in restricted band, its limit is 30dBc of the fundamental emission level (96.5dBμV/m) or 15.209 which is higher.

Note 2: Measure Level (dBμV/m) = Reading Level (dBμV) + Factor (dB)

Factor (dB) = Cable Loss (dB) + Antenna Factor (dB/m) - Pre_Amplifier Gain (dB)

Product	Mobile Data Terminal	Temperature	26°C
Test Engineer	Will Yan	Relative Humidity	56%
Test Site	AC1	Test Date	2017/11/17
Test Mode:	802.11n-HT40	Test Channel:	09
Remark:	1. Average measurement was not performed if peak level lower than average limit. 2. Other frequency was 20dB below limit line within 1-18GHz, there is not show in the report.		

Mark	Frequency (MHz)	Reading Level (dBμV)	Factor (dB)	Measure Level (dBμV/m)	Limit (dBμV/m)	Margin (dB)	Detector	Polarization
	4689.0	33.8	2.3	36.1	74.0	-37.9	Peak	Horizontal
	8471.5	35.4	8.2	43.6	74.0	-30.4	Peak	Horizontal
*	10494.5	31.7	12.4	44.1	77.4	-33.3	Peak	Horizontal
*	13529.0	32.1	13.8	45.9	77.4	-31.5	Peak	Horizontal
	4544.5	36.9	1.8	38.7	74.0	-35.3	Peak	Vertical
	8480.0	35.9	8.3	44.2	74.0	-29.8	Peak	Vertical
*	10426.5	34.0	12.1	46.1	77.4	-31.3	Peak	Vertical
*	13571.5	34.0	13.9	47.9	77.4	-29.5	Peak	Vertical

Note 1: "*" is not in restricted band, its limit is 30dBc of the fundamental emission level (97.4dBμV/m) or 15.209 which is higher.

Note 2: Measure Level (dBμV/m) = Reading Level (dBμV) + Factor (dB)

Factor (dB) = Cable Loss (dB) + Antenna Factor (dB/m) - Pre_Amplifier Gain (dB)

The worst case of Radiated Emission below 1GHz:

Site: AC1	Time: 2017/11/19 - 16:59
Limit: FCC_Part15.209_RE(3m)	Engineer: Will Yan
Probe: VULB 9168 _20-2000MHz	Polarity: Horizontal
EUT: Mobile Data Terminal	Power: AC 120V/60Hz
Note: There is the worst case within frequency range 30MHz~1GHz.	

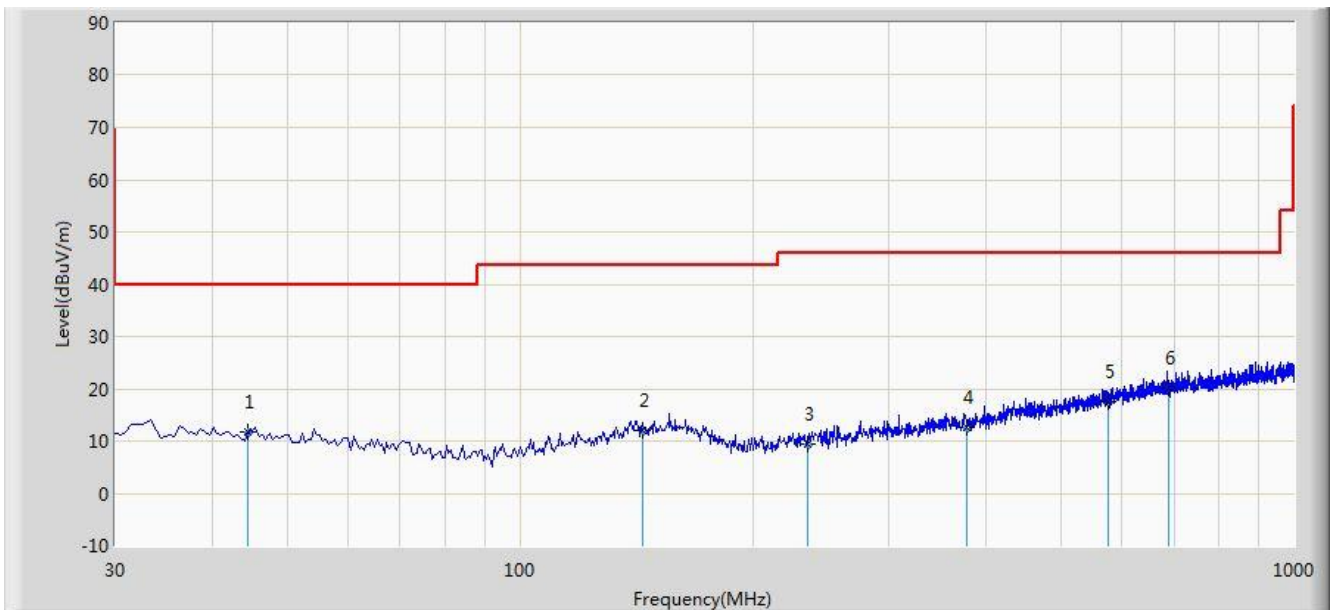

No	Flag	Mark	Frequency (MHz)	Measure Level (dBuV/m)	Reading Level (dBuV)	Margin (dB)	Limit (dBuV/m)	Factor (dB)	Type
1			44.550	11.809	-2.409	-28.191	40.000	14.218	QP
2			143.975	12.083	-2.680	-31.417	43.500	14.763	QP
3			235.155	9.447	-3.193	-36.553	46.000	12.641	QP
4			377.745	12.521	-3.542	-33.479	46.000	16.063	QP
5			576.110	17.634	-2.325	-28.366	46.000	19.959	QP
6		*	690.085	20.048	-1.844	-25.952	46.000	21.892	QP

Note 1: Measure Level (dB μ V/m) = Reading Level (dB μ V) + Factor (dB)

Factor (dB) = Cable Loss (dB) + Antenna Factor (dB/m)

Note 2: The test trace is same as the ambient noise and the amplitude of the emissions are attenuated more than 20dB below the permissible (the test frequency range: 9kHz ~ 30MHz, 18GHz ~ 25GHz), therefore no data appear in the report.

Site: AC1	Time: 2017/11/19 - 17:01
Limit: FCC_Part15.209_RE(3m)	Engineer: Will Yan
Probe: VULB 9168 _20-2000MHz	Polarity: Vertical
EUT: Mobile Data Terminal	Power: AC 120V/60Hz
Note: There is the worst case within frequency range 30MHz~1GHz.	

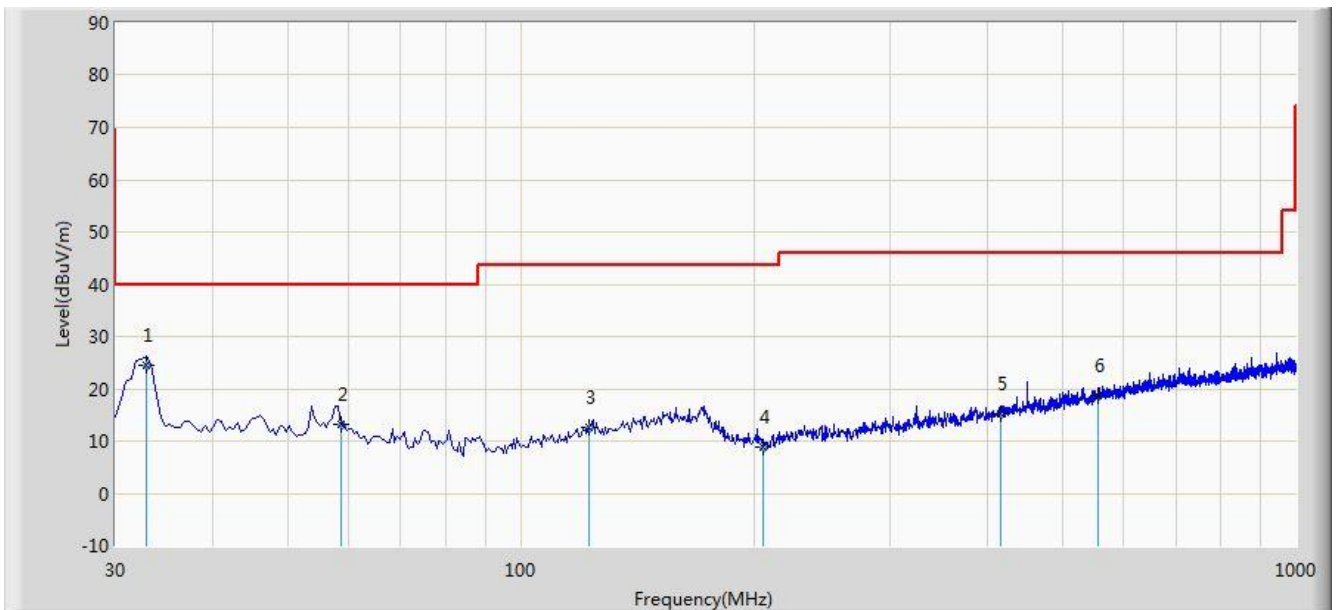

No	Flag	Mark	Frequency (MHz)	Measure Level (dBuV/m)	Reading Level (dBuV)	Margin (dB)	Limit (dBuV/m)	Factor (dB)	Type
1		*	32.910	24.383	10.656	-15.617	40.000	13.727	QP
2			58.615	13.290	-0.168	-26.710	40.000	13.458	QP
3			122.635	12.553	-0.755	-30.947	43.500	13.308	QP
4			205.085	8.943	-2.248	-34.557	43.500	11.190	QP
5			416.545	15.237	-1.695	-30.763	46.000	16.932	QP
6			555.255	18.739	-0.820	-27.261	46.000	19.559	QP

Note 1: Measure Level (dB μ V/m) = Reading Level (dB μ V) + Factor (dB)

Factor (dB) = Cable Loss (dB) + Antenna Factor (dB/m)

Note 2: The test trace is same as the ambient noise and the amplitude of the emissions are attenuated more than 20dB below the permissible (the test frequency range: 9kHz ~ 30MHz, 18GHz ~ 25GHz), therefore no data appear in the report.

7.7. Radiated Restricted Band Edge Measurement

7.7.1. Test Limit

For 15.205 requirement:

Radiated emissions which fall in the restricted bands, as defined in Section 15.205(a) of FCC part 15, must also comply with the radiated emission limits specified in Section 15.209(a).

Frequency (MHz)	Frequency (MHz)	Frequency (MHz)	Frequency (GHz)
0.090 - 0.110	16.42-16.423	399.9 - 410	4.5-5.15
¹ 0.495 - 0.505	16.69475-16.69525	608 - 614	5.35-5.46
2.1735-2.1905	16.80425-16.80475	960 - 1240	7.25-7.75
4.125-4.128	25.5 -25.67	1300 - 1427	8.25 - 8.5
4.17725-4.17775	37.5-38.25	1435-1626.5	9.0-9.2
4.20725-4.20775	73-74.6	1645.5-1646.5	9.3-9.5
6.215-6.218	74.8-75.2	1660 - 1710	10.6-12.7
6.26775-6.26825	108-121.94	1718.8-1722.2	13.25-13.4
6.31175-6.31225	123 - 138	2200 - 2300	14.47-14.5
8.291-8.294	149.9-150.05	2310-2390	15.35-16.2
8.362-8.366	156.52475-156.525	2483.5 - 2500	17.7-21.4
8.37625-8.38675	156.7-156.9	2690 - 2900	22.01-23.12
8.41425-8.41475	162.0125-167.17	3260 - 3267	23.6-24.0
12.29-12.293	167.72-173.2	3332 - 3339	31.2-31.8
12.51975-12.52025	240 - 285	3345.8 - 3358	36.43-36.5
12.57675-12.57725	322-335.4	3600 - 4400	(²)
13.36-13.41	--	--	--

All out of band emissions appearing in a restricted band as specified in Section 15.205 of the Title 47CFR must not exceed the limits shown in Table per Section 15.209.

FCC Part 15 Subpart C Paragraph 15.209		
Frequency [MHz]	Field Strength [uV/m]	Measured Distance [Meters]
0.009 – 0.490	2400/F (kHz)	300
0.490 – 1.705	24000/F (kHz)	30
1.705 - 30	30	30
30 - 88	100	3
88 - 216	150	3
216 - 960	200	3
Above 960	500	3

7.7.2. Test Procedure Used

KDB 558074 D01v04 - Section 12.2.4 (peak power measurements)

KDB 558074 D01v04 - Section 13.3.3 (average power measurements)

7.7.3. Test Setting

Peak Field Strength Measurements

1. Analyzer center frequency was set to the frequency of the radiated spurious emission of interest
2. RBW = 1MHz
3. VBW = 3MHz
4. Detector = peak
5. Sweep time = auto couple
6. Trace mode = max hold
7. Trace was allowed to stabilize

Average Field Strength Measurements

1. Analyzer center frequency was set to the frequency of the radiated spurious emission of interest
2. RBW = 1MHz
3. VBW $\geq 1/T$
4. De As an alternative, the instrument may be set to linear detector mode. Ensure that video filtering is applied in linear voltage domain (rather than in a log or dB domain). Some instruments require linear display mode in order to accomplish this. Others have a setting for Average-VBW Type, which can be set to "Voltage" regardless of the display mode
5. Detector = Peak
6. Sweep time = auto
7. Trace mode = max hold
8. Allow max hold to run for at least 50 times (1/duty cycle) traces

7.7.4. Test Setup

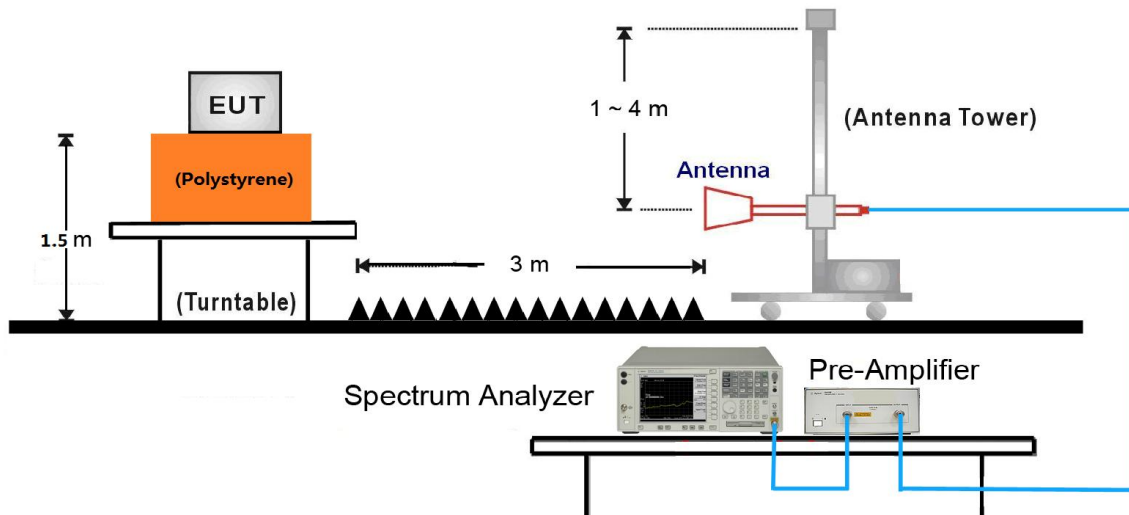

7.7.5. Test Result

Site: AC1	Time: 2017/11/17 - 19:51
Limit: FCC_Part15.209_RE(3m)	Engineer: Will Yan
Probe: BBHA9120D_1-18GHz	Polarity: Horizontal
EUT: Mobile Data Terminal	Power: AC 120V/60Hz
Test Mode: Transmit by 802.11b at channel 2412MHz	

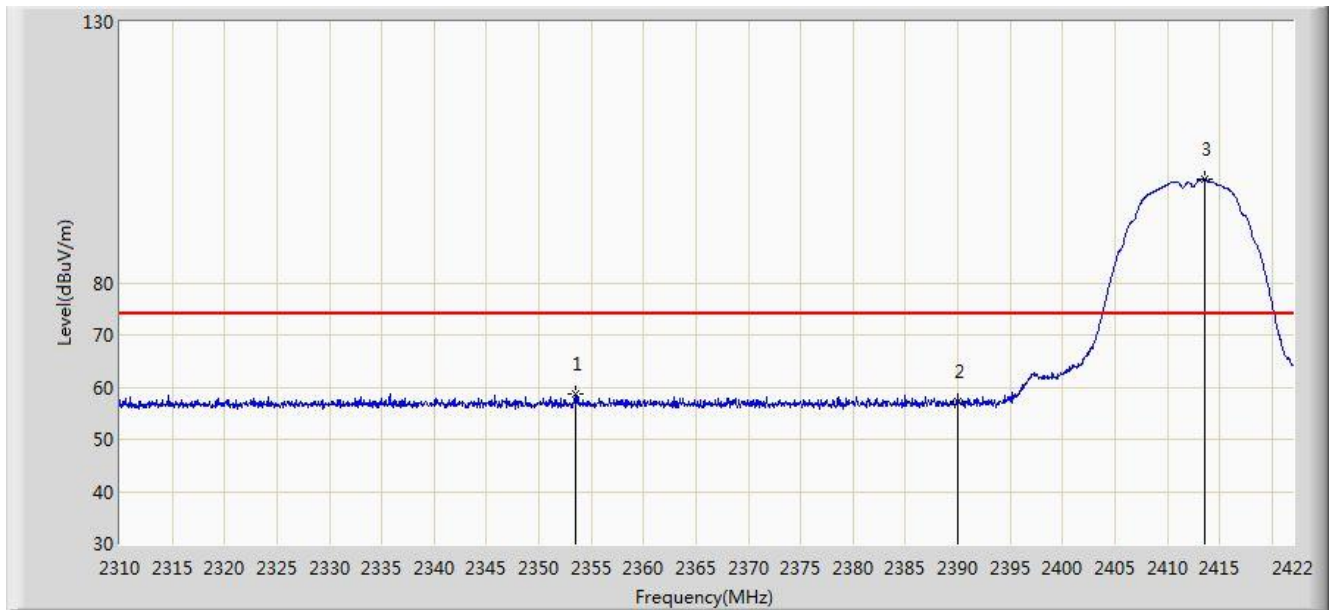

No	Flag	Mark	Frequency (MHz)	Measure Level (dBuV/m)	Reading Level (dBuV)	Over Limit (dB)	Limit (dBuV/m)	Factor (dB)	Type
1			2353.456	58.807	27.528	-15.193	74.000	31.280	PK
2			2390.000	57.376	26.173	-16.624	74.000	31.203	PK
3		*	2413.600	99.766	68.599	N/A	N/A	31.167	PK

Note: Measure Level (dB μ V/m) = Reading Level (dB μ V) + Factor (dB)

Factor (dB) = Cable Loss (dB) + Antenna Factor (dB/m).

Site: AC1	Time: 2017/11/17 - 20:27
Limit: FCC_Part15.209_RE(3m)	Engineer: Will Yan
Probe: BBHA9120D_1-18GHz	Polarity: Horizontal
EUT: Mobile Data Terminal	Power: AC 120V/60Hz
Test Mode: Transmit by 802.11b at channel 2412MHz	

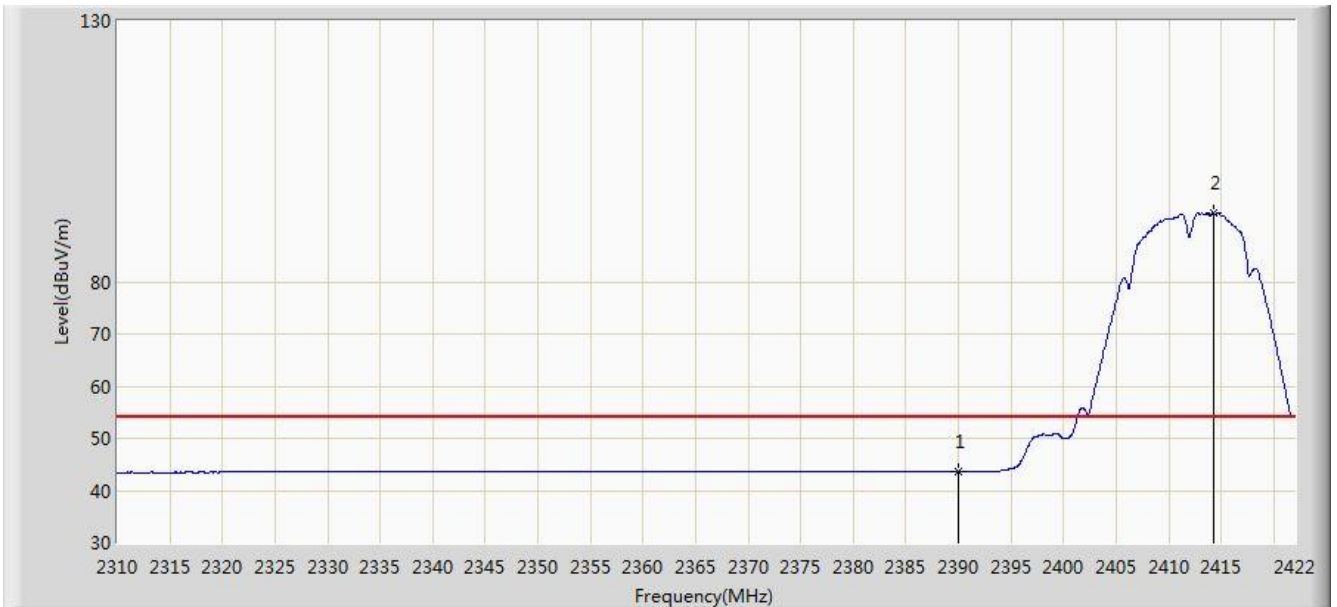

No	Flag	Mark	Frequency (MHz)	Measure Level (dBuV/m)	Reading Level (dBuV)	Over Limit (dB)	Limit (dBuV/m)	Factor (dB)	Type
1			2390.000	43.667	12.464	-10.333	54.000	31.203	AV
2		*	2414.272	93.051	61.885	N/A	N/A	31.166	AV

Note: Measure Level (dB μ V/m) = Reading Level (dB μ V) + Factor (dB)

Factor (dB) = Cable Loss (dB) + Antenna Factor (dB/m).

Site: AC1	Time: 2017/11/17 - 20:29
Limit: FCC_Part15.209_RE(3m)	Engineer: Will Yan
Probe: BBHA9120D_1-18GHz	Polarity: Vertical
EUT: Mobile Data Terminal	Power: AC 120V/60Hz
Test Mode: Transmit by 802.11b at channel 2412MHz	

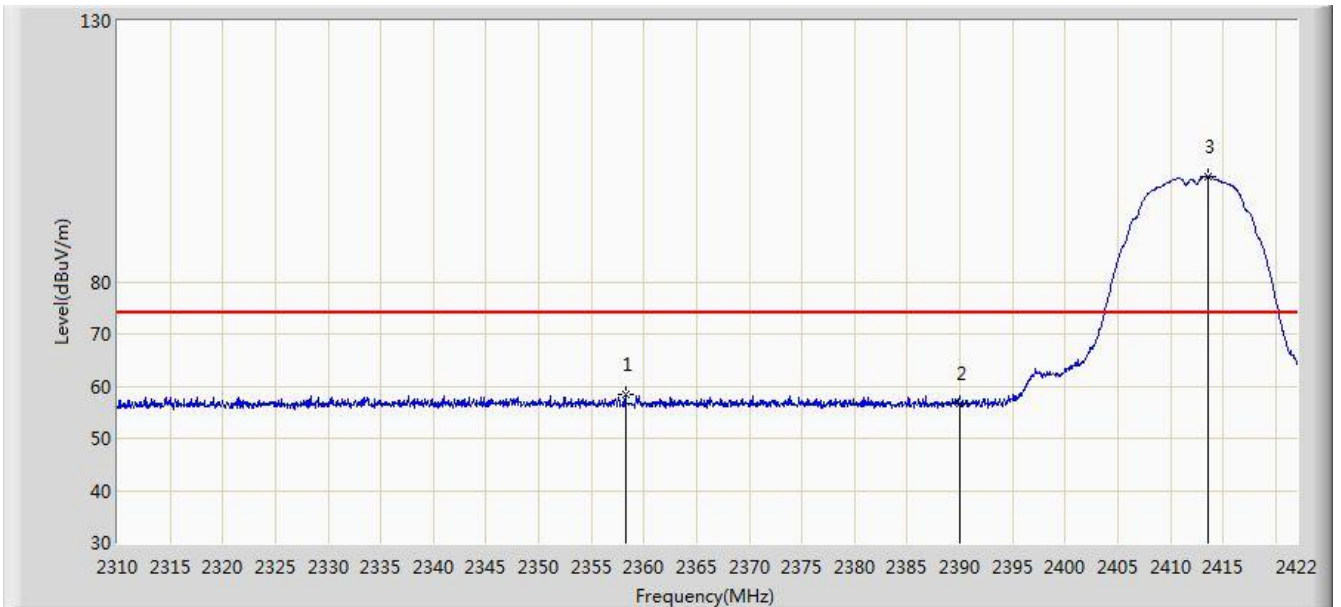

No	Flag	Mark	Frequency (MHz)	Measure Level (dBuV/m)	Reading Level (dBuV)	Over Limit (dB)	Limit (dBuV/m)	Factor (dB)	Type
1			2358.216	58.358	27.095	-15.642	74.000	31.262	PK
2			2390.000	56.617	25.414	-17.383	74.000	31.203	PK
3		*	2413.600	100.168	69.001	N/A	N/A	31.167	PK

Note: Measure Level (dB μ V/m) = Reading Level (dB μ V) + Factor (dB)

Factor (dB) = Cable Loss (dB) + Antenna Factor (dB/m).

Site: AC1	Time: 2017/11/17 - 20:31
Limit: FCC_Part15.209_RE(3m)	Engineer: Will Yan
Probe: BBHA9120D_1-18GHz	Polarity: Vertical
EUT: Mobile Data Terminal	Power: AC 120V/60Hz
Test Mode: Transmit by 802.11b at channel 2412MHz	

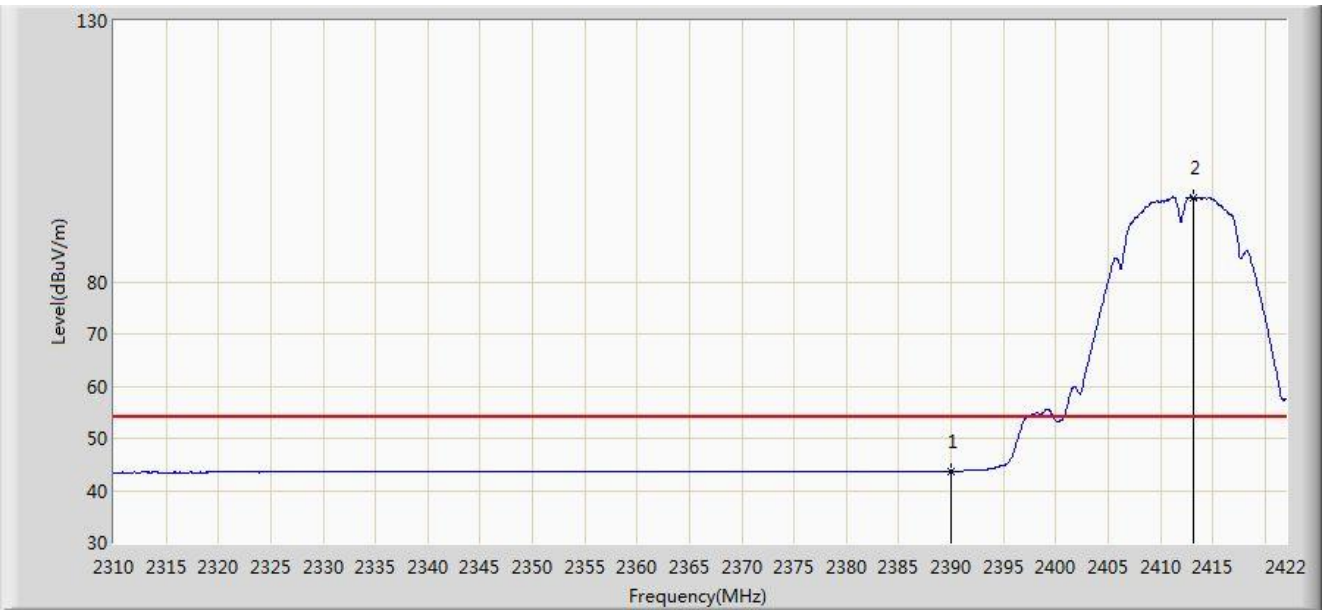

No	Flag	Mark	Frequency (MHz)	Measure Level (dBuV/m)	Reading Level (dBuV)	Over Limit (dB)	Limit (dBuV/m)	Factor (dB)	Type
1			2390.000	43.767	12.564	-10.233	54.000	31.203	AV
2		*	2413.208	96.195	65.028	N/A	N/A	31.167	AV

Note: Measure Level (dBμV/m) = Reading Level (dBμV) + Factor (dB)

Factor (dB) = Cable Loss (dB) + Antenna Factor (dB/m).

Site: AC1	Time: 2017/11/17 - 20:31
Limit: FCC_Part15.209_RE(3m)	Engineer: Will Yan
Probe: BBHA9120D_1-18GHz	Polarity: Horizontal
EUT: Mobile Data Terminal	Power: AC 120V/60Hz
Test Mode: Transmit by 802.11b at channel 2462MHz	

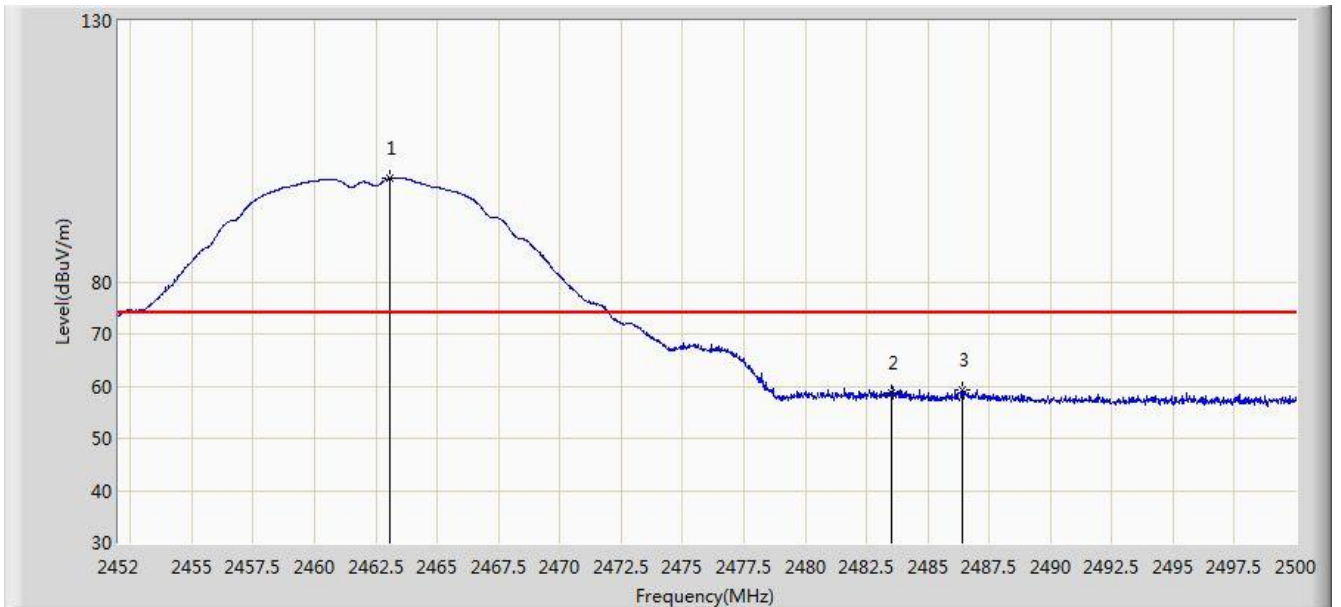

No	Flag	Mark	Frequency (MHz)	Measure Level (dBuV/m)	Reading Level (dBuV)	Over Limit (dB)	Limit (dBuV/m)	Factor (dB)	Type
1		*	2463.088	99.802	68.665	N/A	N/A	31.137	PK
2			2483.500	58.684	27.491	-15.316	74.000	31.194	PK
3			2486.392	59.235	28.034	-14.765	74.000	31.201	PK

Note: Measure Level (dB μ V/m) = Reading Level (dB μ V) + Factor (dB)

Factor (dB) = Cable Loss (dB) + Antenna Factor (dB/m).

Site: AC1	Time: 2017/11/17 - 20:35
Limit: FCC_Part15.209_RE(3m)	Engineer: Will Yan
Probe: BBHA9120D_1-18GHz	Polarity: Horizontal
EUT: Mobile Data Terminal	Power: AC 120V/60Hz
Test Mode: Transmit by 802.11b at channel 2462MHz	

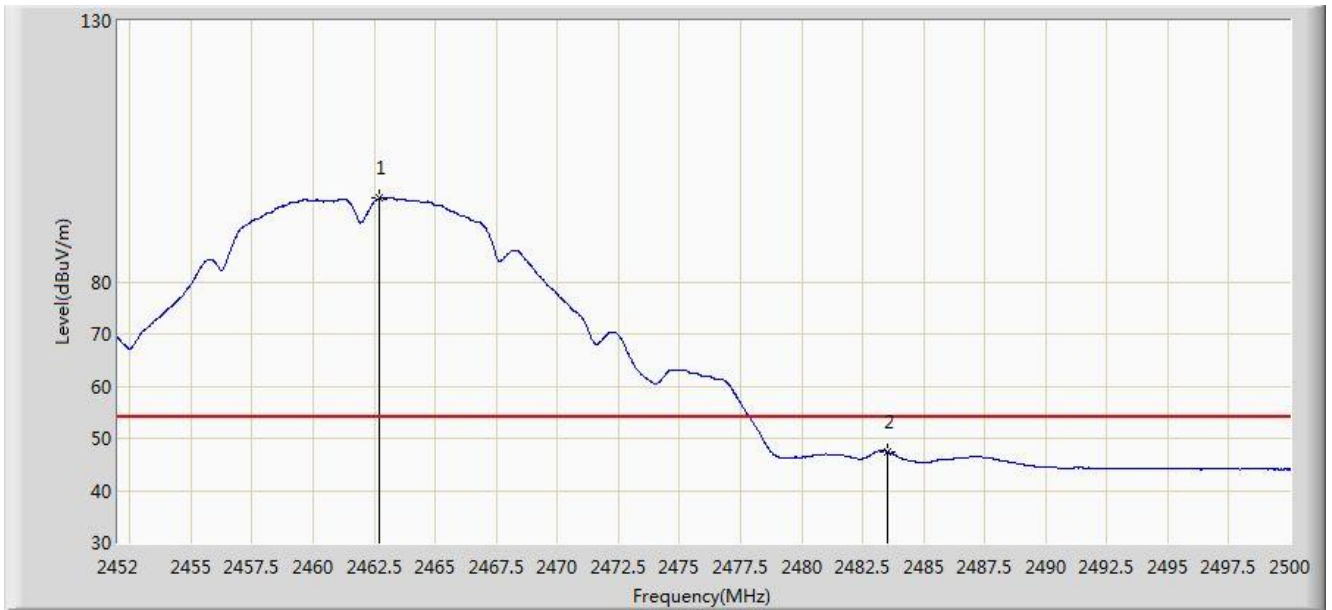

No	Flag	Mark	Frequency (MHz)	Measure Level (dBuV/m)	Reading Level (dBuV)	Over Limit (dB)	Limit (dBuV/m)	Factor (dB)	Type
1		*	2462.728	96.012	64.875	N/A	N/A	31.137	AV
2			2483.500	47.491	16.298	-6.509	54.000	31.194	AV

Note: Measure Level (dB μ V/m) = Reading Level (dB μ V) + Factor (dB)

Factor (dB) = Cable Loss (dB) + Antenna Factor (dB/m).

Site: AC1	Time: 2017/11/17 - 20:36
Limit: FCC_Part15.209_RE(3m)	Engineer: Will Yan
Probe: BBHA9120D_1-18GHz	Polarity: Vertical
EUT: Mobile Data Terminal	Power: AC 120V/60Hz
Test Mode: Transmit by 802.11b at channel 2462MHz	

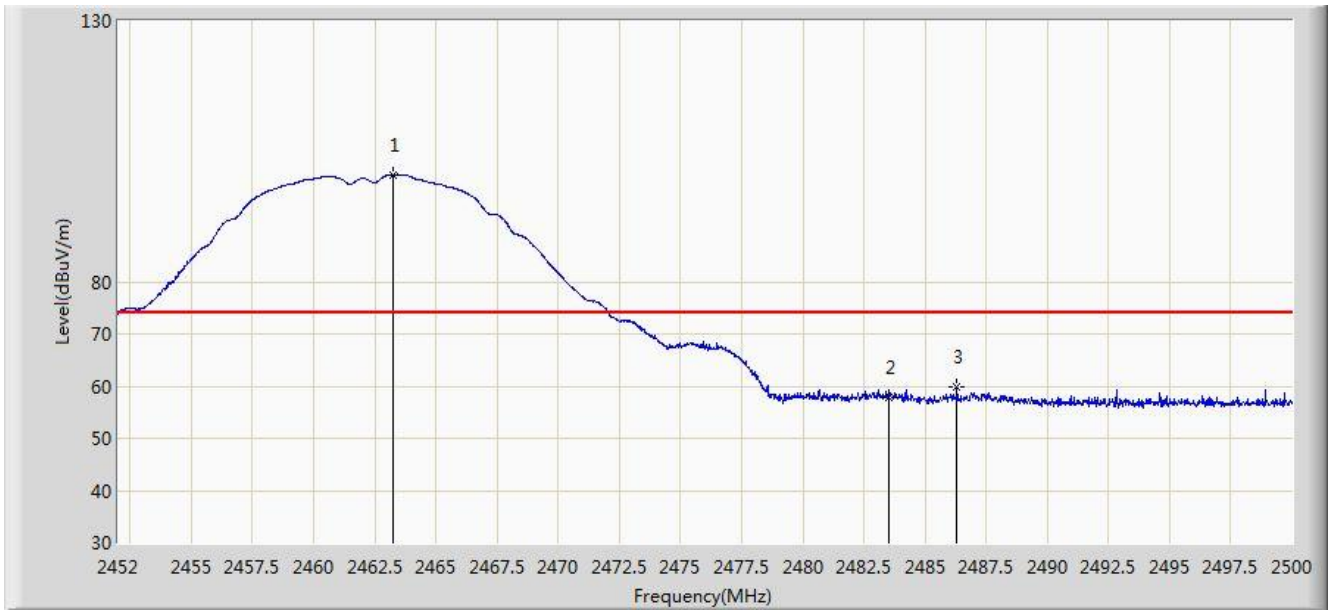

No	Flag	Mark	Frequency (MHz)	Measure Level (dBuV/m)	Reading Level (dBuV)	Over Limit (dB)	Limit (dBuV/m)	Factor (dB)	Type
1		*	2462.256	100.560	69.422	N/A	N/A	31.138	PK
2			2483.500	57.922	26.729	-16.078	74.000	31.194	PK
3			2486.296	59.767	28.566	-14.233	74.000	31.201	PK

Note: Measure Level (dB μ V/m) = Reading Level (dB μ V) + Factor (dB)

Factor (dB) = Cable Loss (dB) + Antenna Factor (dB/m).

Site: AC1	Time: 2017/11/17 - 20:37
Limit: FCC_Part15.209_RE(3m)	Engineer: Will Yan
Probe: BBHA9120D_1-18GHz	Polarity: Vertical
EUT: Mobile Data Terminal	Power: AC 120V/60Hz
Test Mode: Transmit by 802.11b at channel 2462MHz	



No	Flag	Mark	Frequency (MHz)	Measure Level (dBuV/m)	Reading Level (dBuV)	Over Limit (dB)	Limit (dBuV/m)	Factor (dB)	Type
1		*	2462.944	96.674	65.537	N/A	N/A	31.137	AV
2			2483.500	47.716	16.523	-6.284	54.000	31.194	AV

Note: Measure Level (dBuV/m) = Reading Level (dBuV) + Factor (dB)

Factor (dB) = Cable Loss (dB) + Antenna Factor (dB/m).

Site: AC1	Time: 2017/11/17 - 20:38
Limit: FCC_Part15.209_RE(3m)	Engineer: Will Yan
Probe: BBHA9120D_1-18GHz	Polarity: Horizontal
EUT: Mobile Data Terminal	Power: AC 120V/60Hz
Test Mode: Transmit by 802.11g at channel 2412MHz	

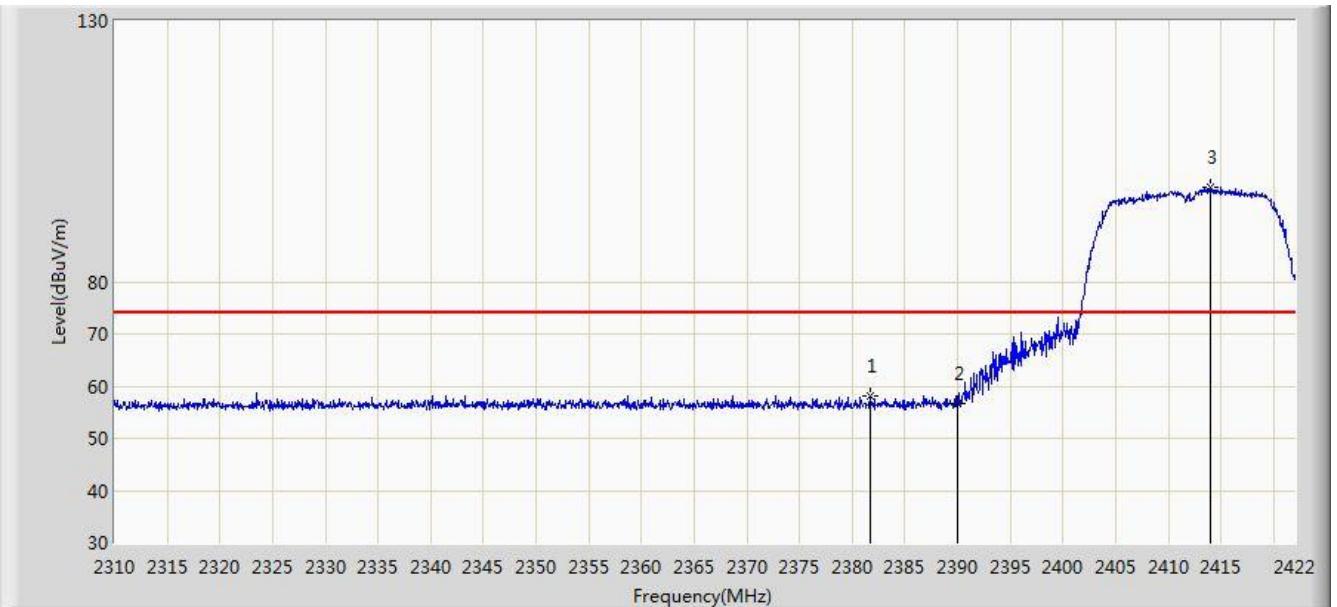

No	Flag	Mark	Frequency (MHz)	Measure Level (dBuV/m)	Reading Level (dBuV)	Over Limit (dB)	Limit (dBuV/m)	Factor (dB)	Type
1			2381.680	58.130	26.912	-15.870	74.000	31.218	PK
2			2390.000	56.700	25.497	-17.300	74.000	31.203	PK
3		*	2413.936	97.992	66.826	N/A	N/A	31.166	PK

Note: Measure Level (dB μ V/m) = Reading Level (dB μ V) + Factor (dB)

Factor (dB) = Cable Loss (dB) + Antenna Factor (dB/m).

Site: AC1	Time: 2017/11/17 - 20:40
Limit: FCC_Part15.209_RE(3m)	Engineer: Will Yan
Probe: BBHA9120D_1-18GHz	Polarity: Horizontal
EUT: Mobile Data Terminal	Power: AC 120V/60Hz
Test Mode: Transmit by 802.11g at channel 2412MHz	

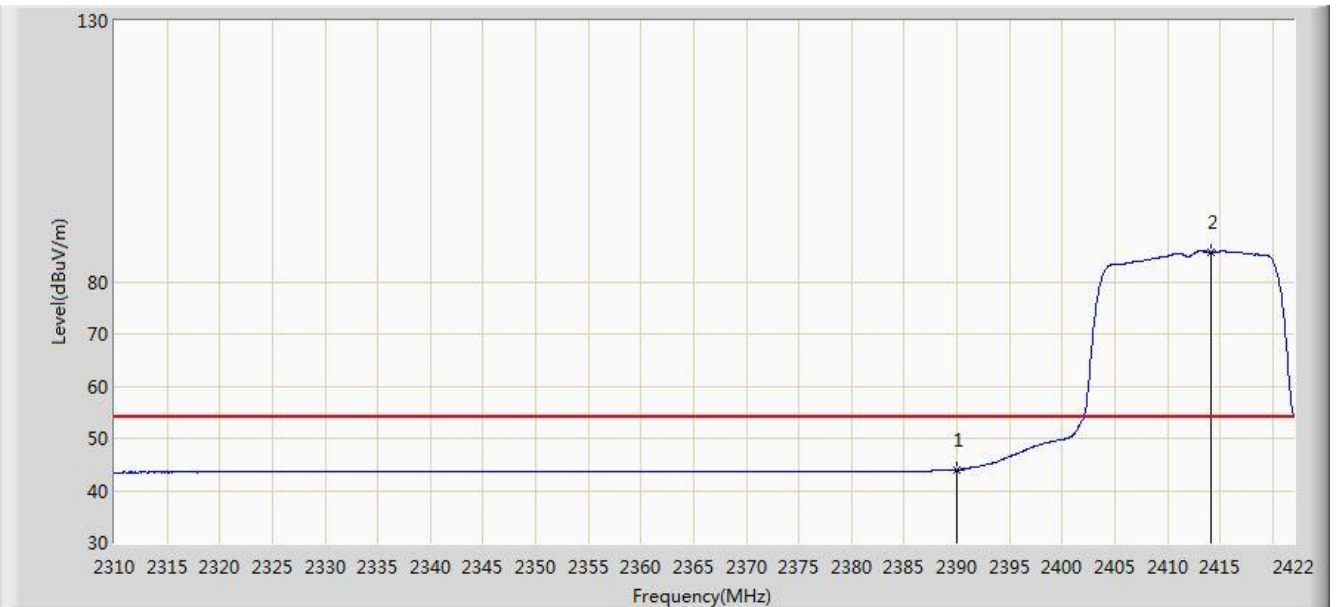

No	Flag	Mark	Frequency (MHz)	Measure Level (dBuV/m)	Reading Level (dBuV)	Over Limit (dB)	Limit (dBuV/m)	Factor (dB)	Type
1			2390.000	43.995	12.792	-10.005	54.000	31.203	AV
2		*	2414.160	85.760	54.594	N/A	N/A	31.166	AV

Note: Measure Level (dBuV/m) = Reading Level (dBuV) + Factor (dB)

Factor (dB) = Cable Loss (dB) + Antenna Factor (dB/m).

Site: AC1	Time: 2017/11/17 - 20:41
Limit: FCC_Part15.209_RE(3m)	Engineer: Will Yan
Probe: BBHA9120D_1-18GHz	Polarity: Vertical
EUT: Mobile Data Terminal	Power: AC 120V/60Hz
Test Mode: Transmit by 802.11g at channel 2412MHz	

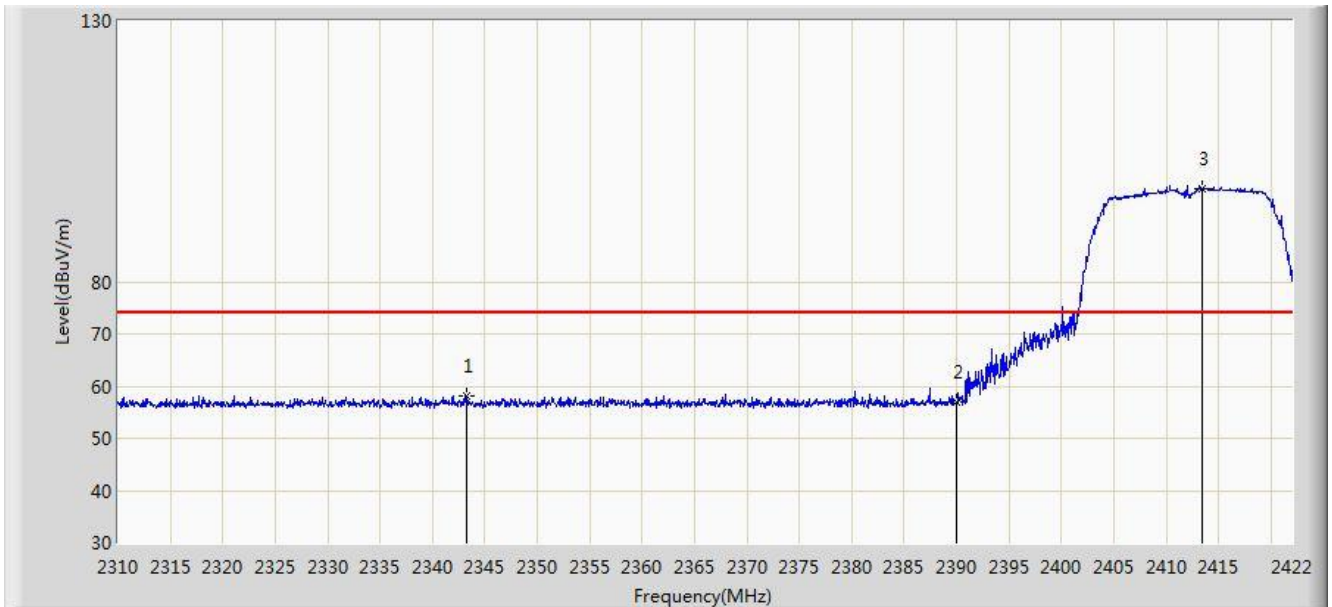

No	Flag	Mark	Frequency (MHz)	Measure Level (dBuV/m)	Reading Level (dBuV)	Over Limit (dB)	Limit (dBuV/m)	Factor (dB)	Type
1			2343.208	58.214	26.896	-15.786	74.000	31.318	PK
2			2390.000	56.858	25.655	-17.142	74.000	31.203	PK
3		*	2413.488	97.881	66.714	N/A	N/A	31.167	PK

Note: Measure Level (dB μ V/m) = Reading Level (dB μ V) + Factor (dB)

Factor (dB) = Cable Loss (dB) + Antenna Factor (dB/m).

Site: AC1	Time: 2017/11/17 - 20:43
Limit: FCC_Part15.209_RE(3m)	Engineer: Will Yan
Probe: BBHA9120D_1-18GHz	Polarity: Vertical
EUT: Mobile Data Terminal	Power: AC 120V/60Hz
Test Mode: Transmit by 802.11g at channel 2412MHz	

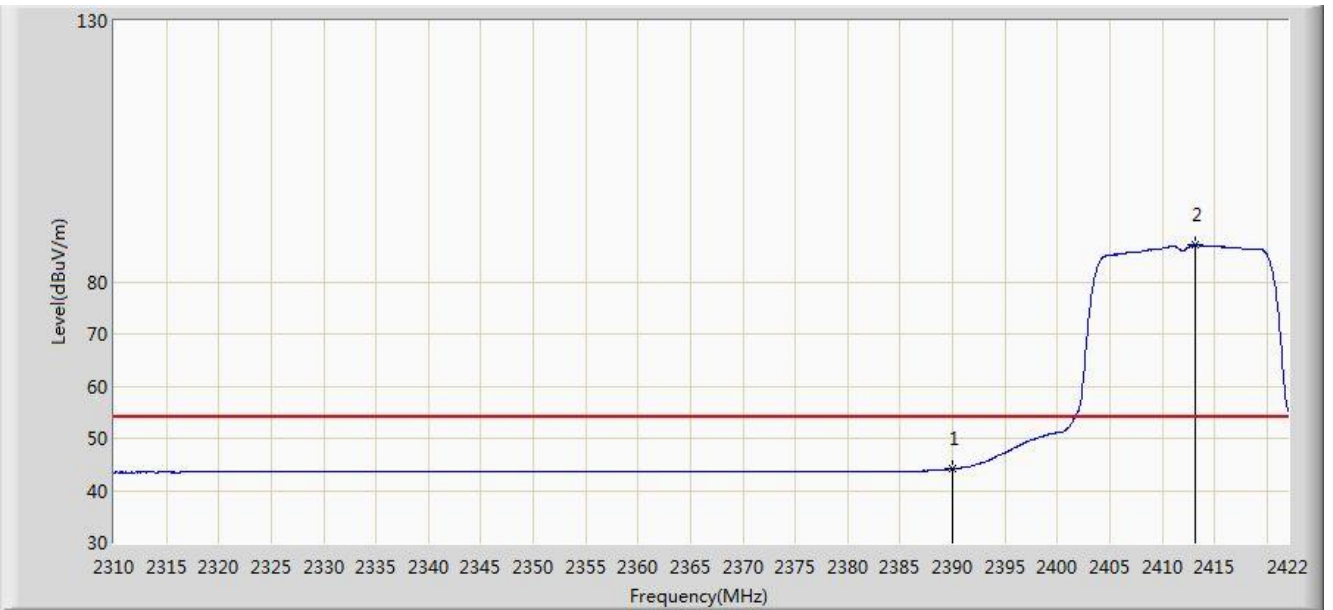

No	Flag	Mark	Frequency (MHz)	Measure Level (dBuV/m)	Reading Level (dBuV)	Over Limit (dB)	Limit (dBuV/m)	Factor (dB)	Type
1			2390.000	44.119	12.916	-9.881	54.000	31.203	AV
2		*	2413.208	87.009	55.842	N/A	N/A	31.167	AV

Note: Measure Level (dBuV/m) = Reading Level (dBuV) + Factor (dB)

Factor (dB) = Cable Loss (dB) + Antenna Factor (dB/m).

Site: AC1	Time: 2017/11/17 - 20:43
Limit: FCC_Part15.209_RE(3m)	Engineer: Will Yan
Probe: BBHA9120D_1-18GHz	Polarity: Horizontal
EUT: Mobile Data Terminal	Power: AC 120V/60Hz
Test Mode: Transmit by 802.11g at channel 2462MHz	

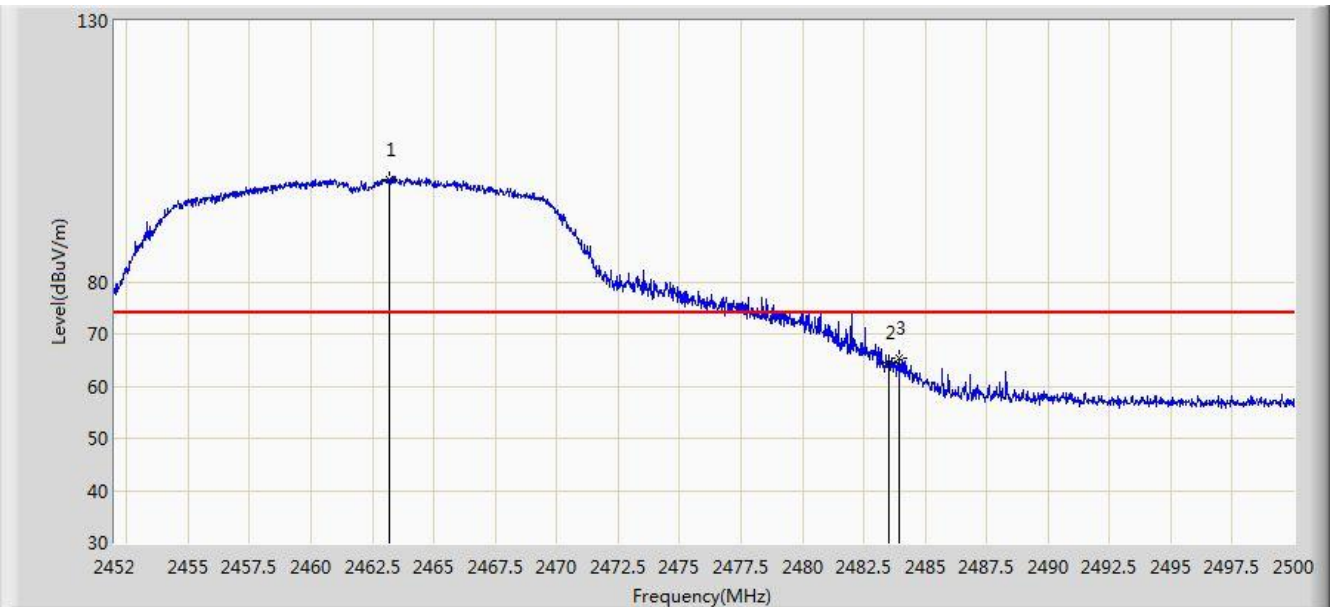

No	Flag	Mark	Frequency (MHz)	Measure Level (dBuV/m)	Reading Level (dBuV)	Over Limit (dB)	Limit (dBuV/m)	Factor (dB)	Type
1		*	2463.184	99.576	68.438	N/A	N/A	31.137	PK
2			2483.500	64.410	33.217	-9.590	74.000	31.194	PK
3			2483.920	65.394	34.200	-8.606	74.000	31.194	PK

Note: Measure Level (dB μ V/m) = Reading Level (dB μ V) + Factor (dB)

Factor (dB) = Cable Loss (dB) + Antenna Factor (dB/m).

Site: AC1	Time: 2017/11/17 - 20:46
Limit: FCC_Part15.209_RE(3m)	Engineer: Will Yan
Probe: BBHA9120D_1-18GHz	Polarity: Horizontal
EUT: Mobile Data Terminal	Power: AC 120V/60Hz
Test Mode: Transmit by 802.11g at channel 2462MHz	

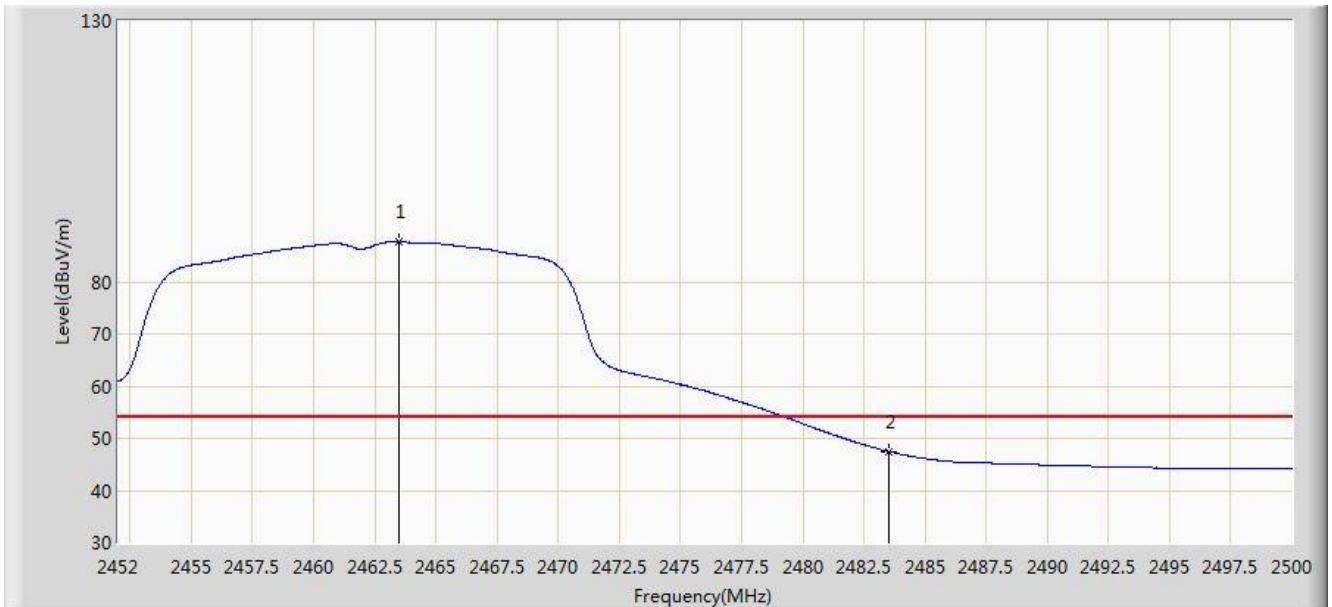

No	Flag	Mark	Frequency (MHz)	Measure Level (dBuV/m)	Reading Level (dBuV)	Over Limit (dB)	Limit (dBuV/m)	Factor (dB)	Type
1		*	2463.472	87.645	56.507	N/A	N/A	31.138	AV
2			2483.500	47.483	16.290	-6.517	54.000	31.194	AV

Note: Measure Level (dBuV/m) = Reading Level (dBuV) + Factor (dB)

Factor (dB) = Cable Loss (dB) + Antenna Factor (dB/m).

Site: AC1	Time: 2017/11/17 - 20:46
Limit: FCC_Part15.209_RE(3m)	Engineer: Will Yan
Probe: BBHA9120D_1-18GHz	Polarity: Vertical
EUT: Mobile Data Terminal	Power: AC 120V/60Hz
Test Mode: Transmit by 802.11g at channel 2462MHz	

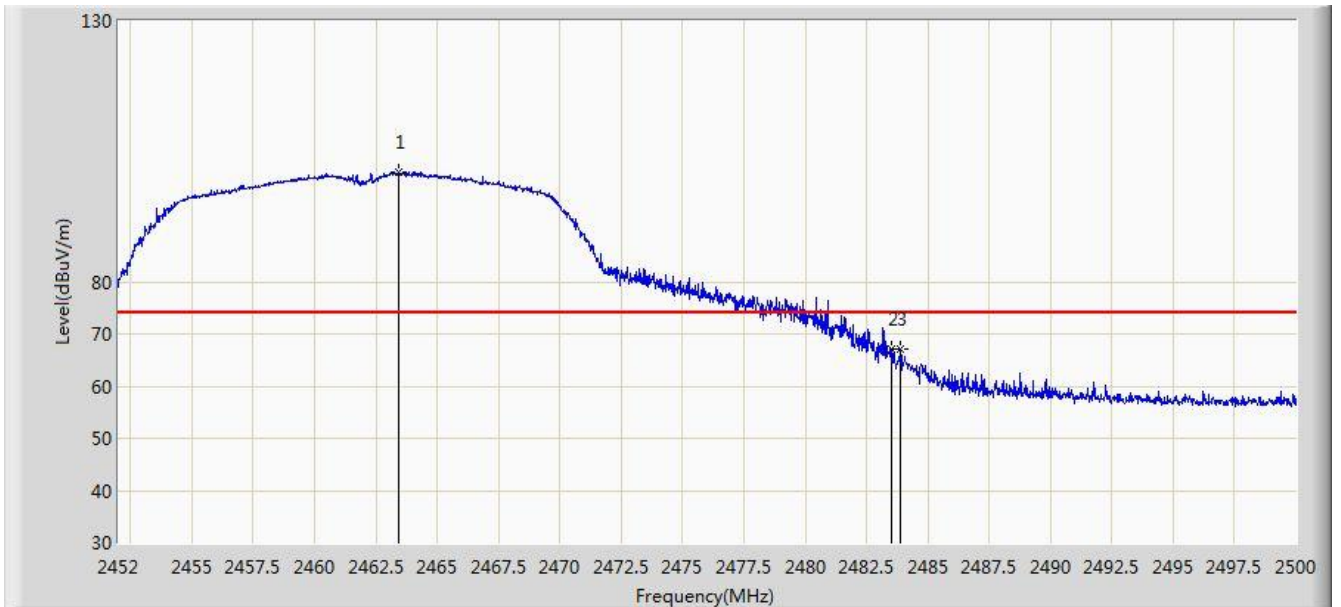

No	Flag	Mark	Frequency (MHz)	Measure Level (dBuV/m)	Reading Level (dBuV)	Over Limit (dB)	Limit (dBuV/m)	Factor (dB)	Type
1		*	2463.400	101.007	69.869	N/A	N/A	31.138	PK
2			2483.500	67.166	35.973	-6.834	74.000	31.194	PK
3			2483.896	67.185	35.991	-6.815	74.000	31.194	PK

Note: Measure Level (dB μ V/m) = Reading Level (dB μ V) + Factor (dB)

Factor (dB) = Cable Loss (dB) + Antenna Factor (dB/m).

Site: AC1	Time: 2017/11/17 - 20:48
Limit: FCC_Part15.209_RE(3m)	Engineer: Will Yan
Probe: BBHA9120D_1-18GHz	Polarity: Vertical
EUT: Mobile Data Terminal	Power: AC 120V/60Hz
Test Mode: Transmit by 802.11g at channel 2462MHz	

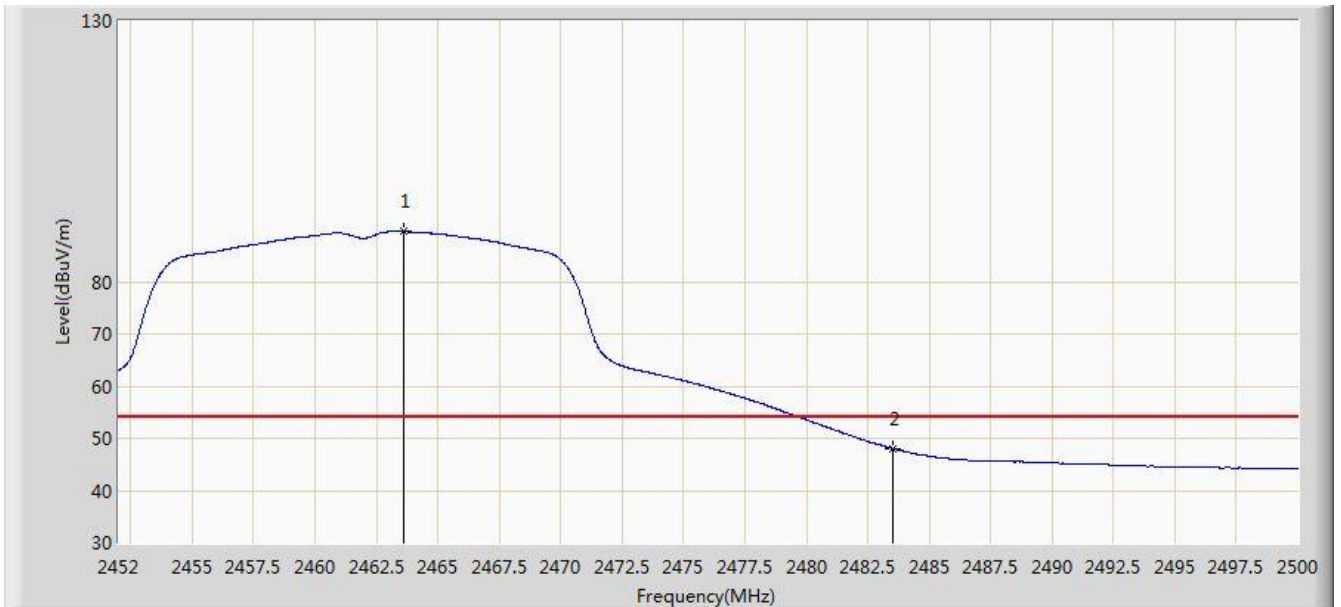

No	Flag	Mark	Frequency (MHz)	Measure Level (dBuV/m)	Reading Level (dBuV)	Over Limit (dB)	Limit (dBuV/m)	Factor (dB)	Type
1		*	2463.616	89.608	58.470	N/A	N/A	31.139	AV
2			2483.500	48.052	16.859	-5.948	54.000	31.194	AV

Note: Measure Level (dBuV/m) = Reading Level (dBuV) + Factor (dB)

Factor (dB) = Cable Loss (dB) + Antenna Factor (dB/m).

Site: AC1	Time: 2017/11/17 - 20:48
Limit: FCC_Part15.209_RE(3m)	Engineer: Will Yan
Probe: BBHA9120D_1-18GHz	Polarity: Horizontal
EUT: Mobile Data Terminal	Power: AC 120V/60Hz
Test Mode: Transmit by 802.11n-HT20 at channel 2412MHz	

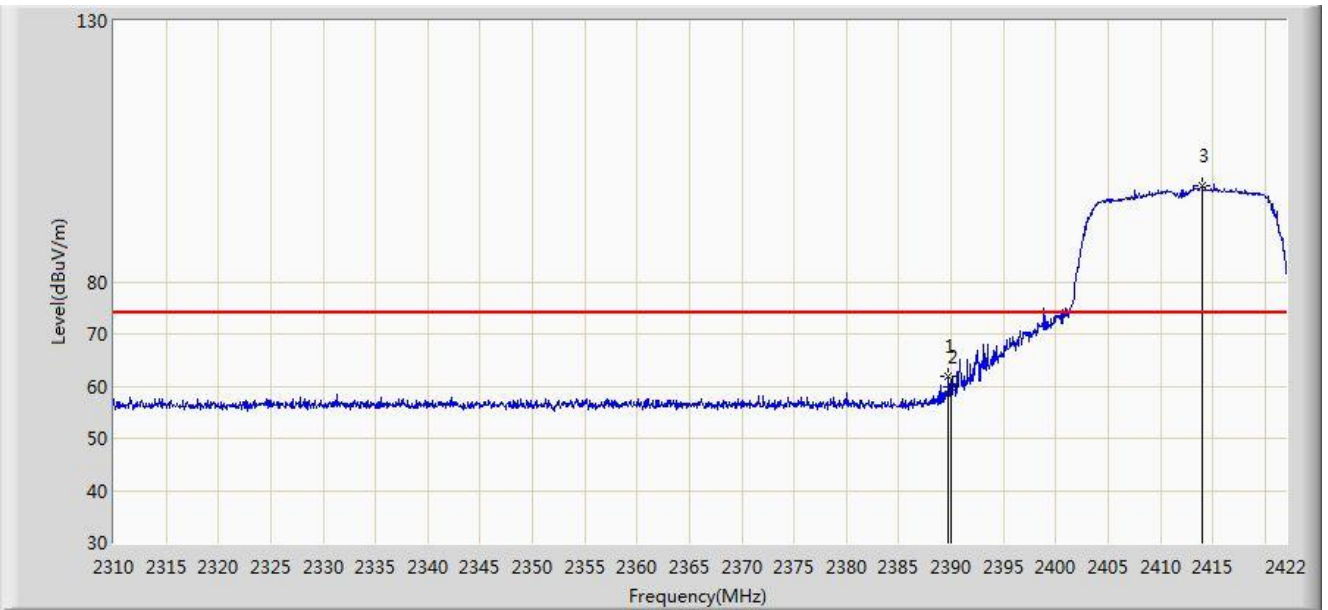

No	Flag	Mark	Frequency (MHz)	Measure Level (dBuV/m)	Reading Level (dBuV)	Over Limit (dB)	Limit (dBuV/m)	Factor (dB)	Type
1			2389.744	61.976	30.773	-12.024	74.000	31.203	PK
2			2390.000	59.935	28.732	-14.065	74.000	31.203	PK
3		*	2413.936	98.323	67.157	N/A	N/A	31.166	PK

Note: Measure Level (dB μ V/m) = Reading Level (dB μ V) + Factor (dB)

Factor (dB) = Cable Loss (dB) + Antenna Factor (dB/m).

Site: AC1	Time: 2017/11/17 - 20:51
Limit: FCC_Part15.209_RE(3m)	Engineer: Will Yan
Probe: BBHA9120D_1-18GHz	Polarity: Horizontal
EUT: Mobile Data Terminal	Power: AC 120V/60Hz
Test Mode: Transmit by 802.11n-HT20 at channel 2412MHz	

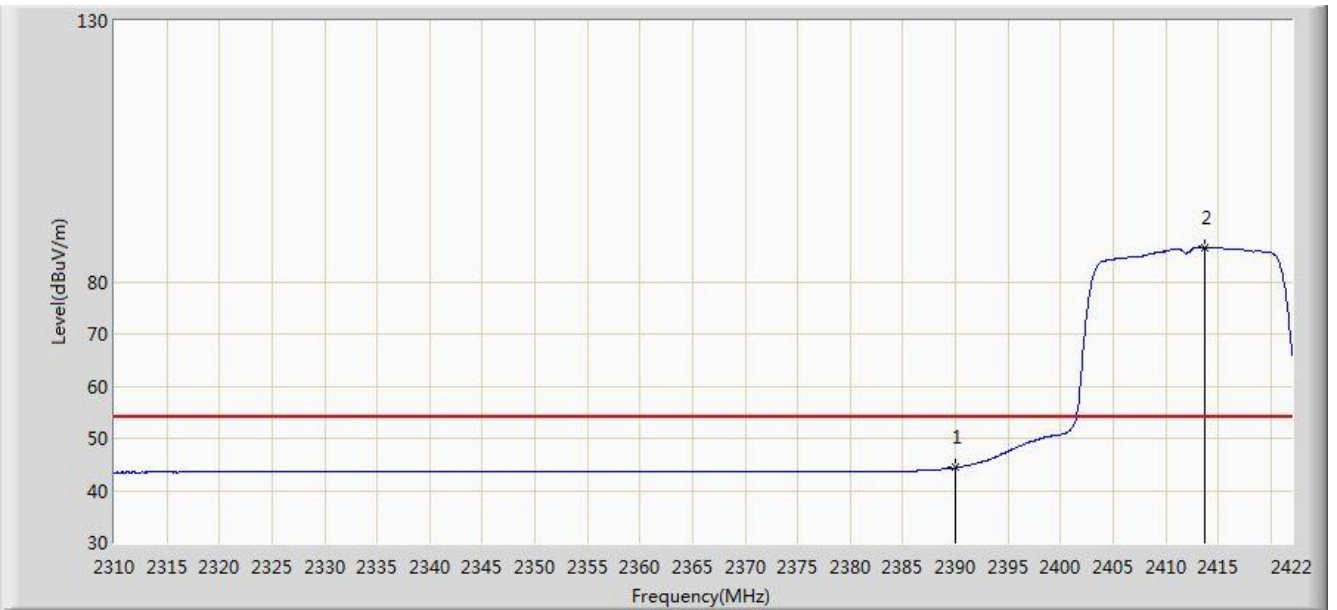

No	Flag	Mark	Frequency (MHz)	Measure Level (dBuV/m)	Reading Level (dBuV)	Over Limit (dB)	Limit (dBuV/m)	Factor (dB)	Type
1			2390.000	44.362	13.159	-9.638	54.000	31.203	AV
2		*	2413.768	86.578	55.411	N/A	N/A	31.167	AV

Note: Measure Level (dBuV/m) = Reading Level (dBuV) + Factor (dB)

Factor (dB) = Cable Loss (dB) + Antenna Factor (dB/m).

Site: AC1	Time: 2017/11/17 - 20:52
Limit: FCC_Part15.209_RE(3m)	Engineer: Will Yan
Probe: BBHA9120D_1-18GHz	Polarity: Vertical
EUT: Mobile Data Terminal	Power: AC 120V/60Hz
Test Mode: Transmit by 802.11n-HT20 at channel 2412MHz	

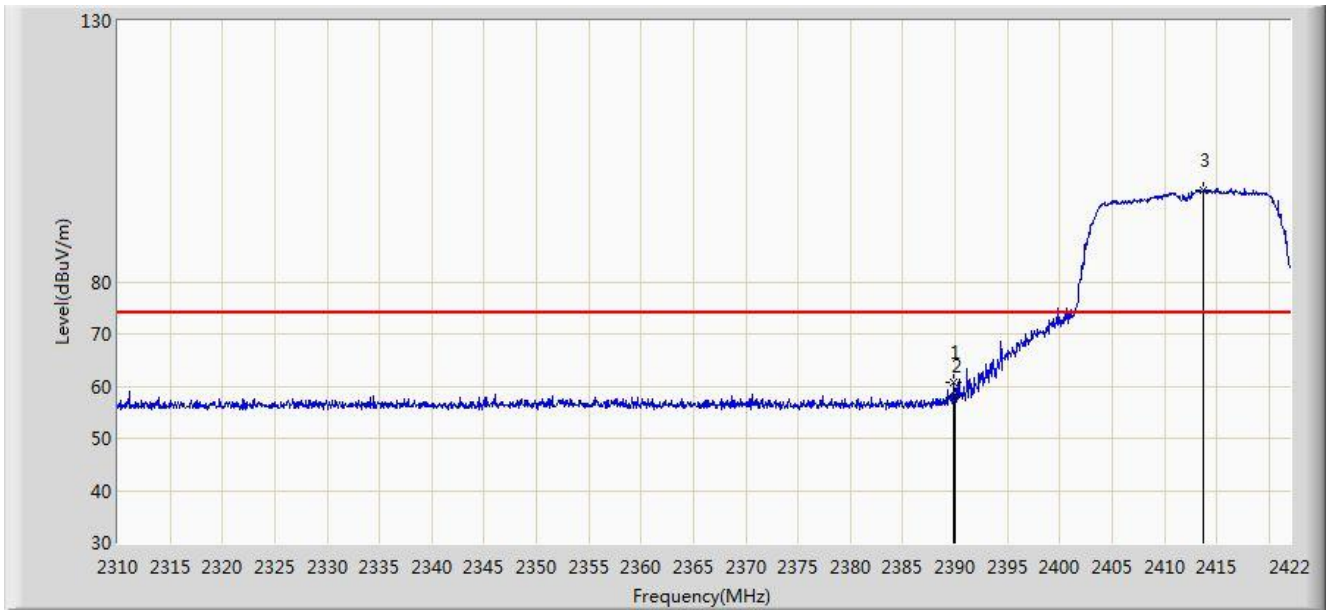

No	Flag	Mark	Frequency (MHz)	Measure Level (dBuV/m)	Reading Level (dBuV)	Over Limit (dB)	Limit (dBuV/m)	Factor (dB)	Type
1			2389.800	60.617	29.414	-13.383	74.000	31.203	PK
2			2390.000	58.073	26.870	-15.927	74.000	31.203	PK
3		*	2413.656	97.552	66.385	N/A	N/A	31.167	PK

Note: Measure Level (dB μ V/m) = Reading Level (dB μ V) + Factor (dB)

Factor (dB) = Cable Loss (dB) + Antenna Factor (dB/m).

Site: AC1	Time: 2017/11/17 - 20:53
Limit: FCC_Part15.209_RE(3m)	Engineer: Will Yan
Probe: BBHA9120D_1-18GHz	Polarity: Vertical
EUT: Mobile Data Terminal	Power: AC 120V/60Hz
Test Mode: Transmit by 802.11n-HT20 at channel 2412MHz	

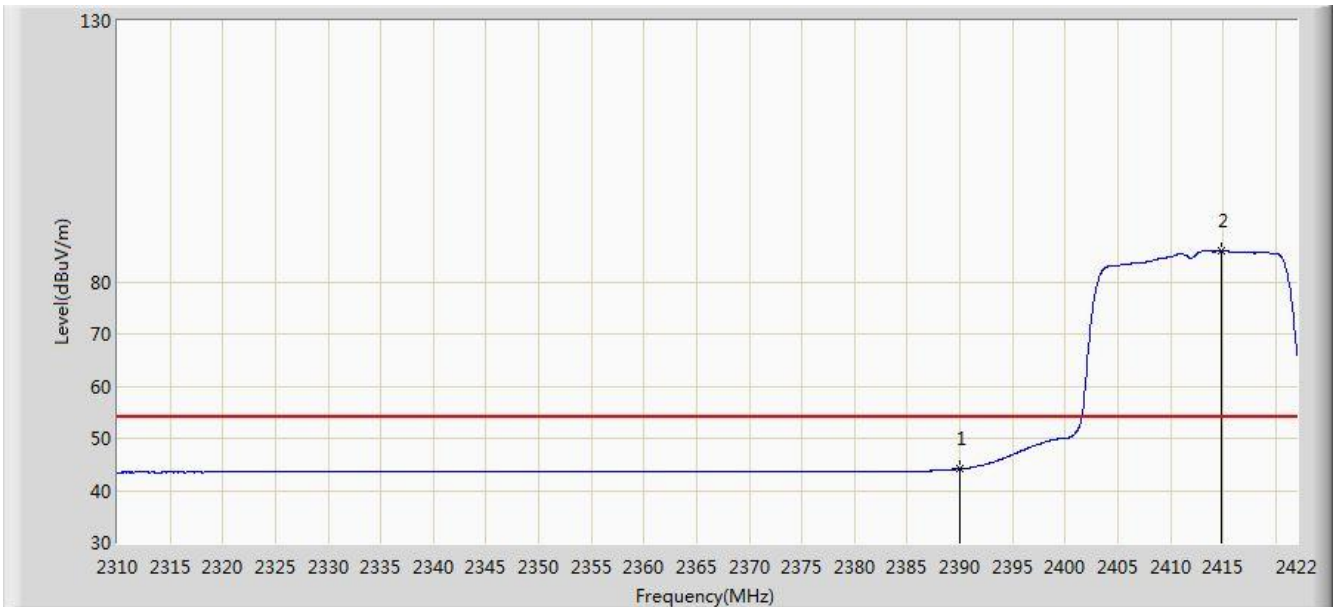

No	Flag	Mark	Frequency (MHz)	Measure Level (dBuV/m)	Reading Level (dBuV)	Over Limit (dB)	Limit (dBuV/m)	Factor (dB)	Type
1			2390.000	44.168	12.965	-9.832	54.000	31.203	AV
2		*	2414.776	85.893	54.728	N/A	N/A	31.164	AV

Note: Measure Level (dB μ V/m) = Reading Level (dB μ V) + Factor (dB)

Factor (dB) = Cable Loss (dB) + Antenna Factor (dB/m).

Site: AC1	Time: 2017/11/17 - 20:54
Limit: FCC_Part15.209_RE(3m)	Engineer: Will Yan
Probe: BBHA9120D_1-18GHz	Polarity: Horizontal
EUT: Mobile Data Terminal	Power: AC 120V/60Hz
Test Mode: Transmit by 802.11n-HT20 at channel 2462MHz	

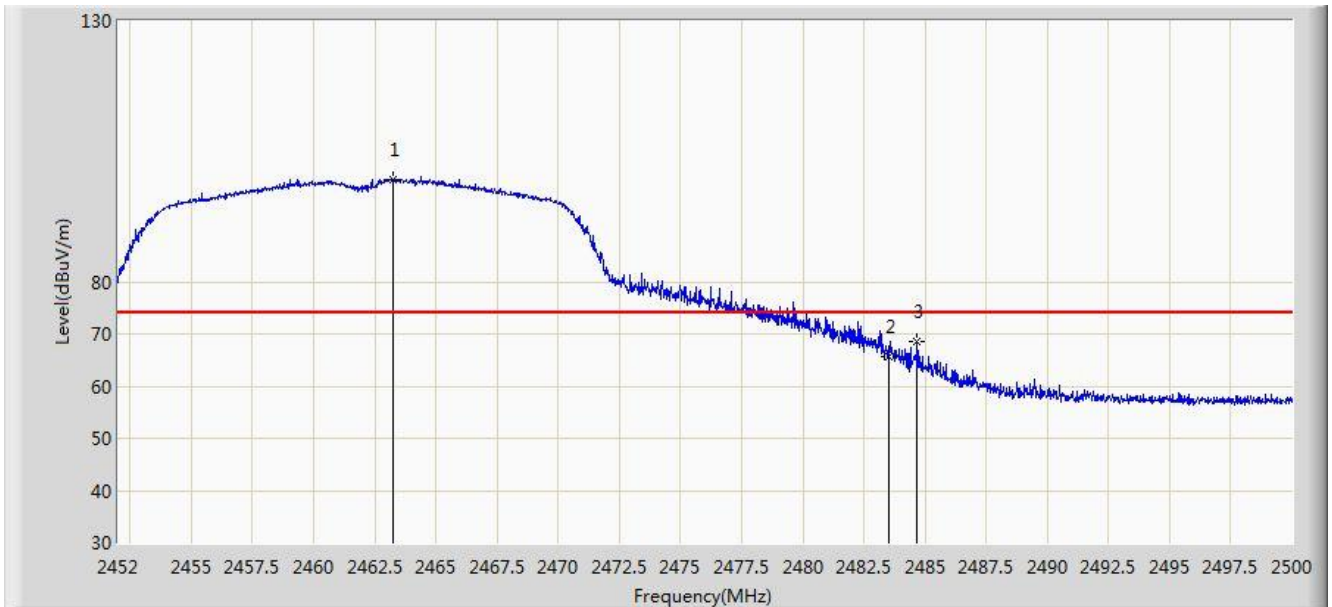

No	Flag	Mark	Frequency (MHz)	Measure Level (dBuV/m)	Reading Level (dBuV)	Over Limit (dB)	Limit (dBuV/m)	Factor (dB)	Type
1		*	2463.256	99.590	68.452	N/A	N/A	31.138	PK
2			2483.500	65.551	34.358	-8.449	74.000	31.194	PK
3			2484.664	68.473	37.277	-5.527	74.000	31.197	PK

Note: Measure Level (dB μ V/m) = Reading Level (dB μ V) + Factor (dB)

Factor (dB) = Cable Loss (dB) + Antenna Factor (dB/m).

Site: AC1	Time: 2017/11/17 - 20:59
Limit: FCC_Part15.209_RE(3m)	Engineer: Will Yan
Probe: BBHA9120D_1-18GHz	Polarity: Horizontal
EUT: Mobile Data Terminal	Power: AC 120V/60Hz
Test Mode: Transmit by 802.11n-HT20 at channel 2462MHz	

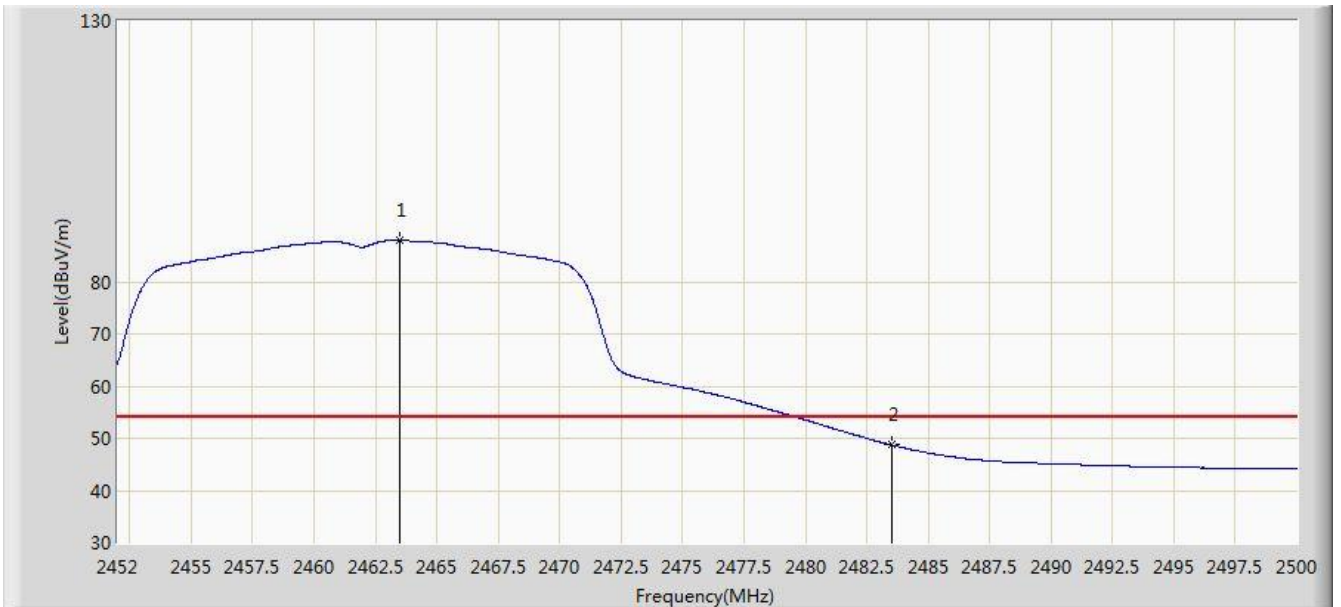

No	Flag	Mark	Frequency (MHz)	Measure Level (dBuV/m)	Reading Level (dBuV)	Over Limit (dB)	Limit (dBuV/m)	Factor (dB)	Type
1		*	2463.472	88.026	56.888	N/A	N/A	31.138	AV
2			2483.500	48.743	17.550	-5.257	54.000	31.194	AV

Note: Measure Level (dB μ V/m) = Reading Level (dB μ V) + Factor (dB)

Factor (dB) = Cable Loss (dB) + Antenna Factor (dB/m).

Site: AC1	Time: 2017/11/17 - 21:00
Limit: FCC_Part15.209_RE(3m)	Engineer: Will Yan
Probe: BBHA9120D_1-18GHz	Polarity: Vertical
EUT: Mobile Data Terminal	Power: AC 120V/60Hz
Test Mode: Transmit by 802.11n-HT20 at channel 2462MHz	

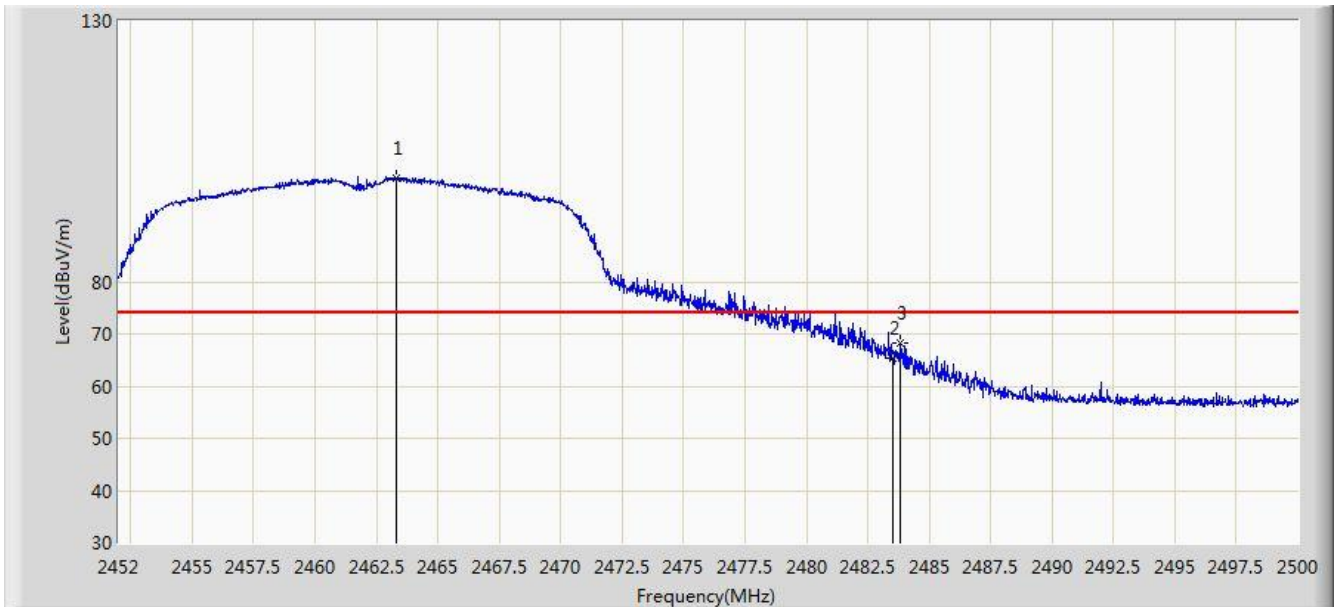

No	Flag	Mark	Frequency (MHz)	Measure Level (dBuV/m)	Reading Level (dBuV)	Over Limit (dB)	Limit (dBuV/m)	Factor (dB)	Type
1		*	2463.328	99.989	68.851	N/A	N/A	31.138	PK
2			2483.500	65.419	34.226	-8.581	74.000	31.194	PK
3			2483.824	68.276	37.082	-5.724	74.000	31.194	PK

Note: Measure Level (dB μ V/m) = Reading Level (dB μ V) + Factor (dB)

Factor (dB) = Cable Loss (dB) + Antenna Factor (dB/m).

Site: AC1	Time: 2017/11/17 - 21:01
Limit: FCC_Part15.209_RE(3m)	Engineer: Will Yan
Probe: BBHA9120D_1-18GHz	Polarity: Vertical
EUT: Mobile Data Terminal	Power: AC 120V/60Hz
Test Mode: Transmit by 802.11n-HT20 at channel 2462MHz	

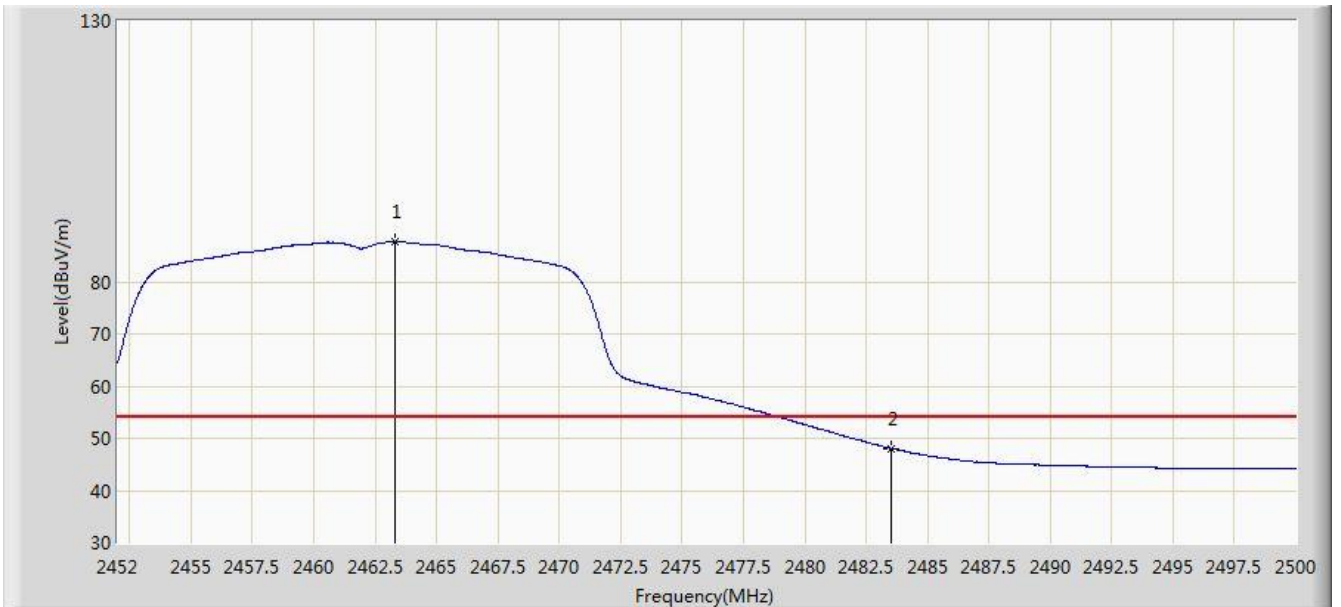

No	Flag	Mark	Frequency (MHz)	Measure Level (dBuV/m)	Reading Level (dBuV)	Over Limit (dB)	Limit (dBuV/m)	Factor (dB)	Type
1		*	2463.328	87.707	56.569	N/A	N/A	31.138	AV
2			2483.500	48.074	16.881	-5.926	54.000	31.194	AV

Note: Measure Level (dBuV/m) = Reading Level (dBuV) + Factor (dB)

Factor (dB) = Cable Loss (dB) + Antenna Factor (dB/m).

Site: AC1	Time: 2017/11/17 - 21:02
Limit: FCC_Part15.209_RE(3m)	Engineer: Will Yan
Probe: BBHA9120D_1-18GHz	Polarity: Horizontal
EUT: Mobile Data Terminal	Power: AC 120V/60Hz
Test Mode: Transmit by 802.11n-HT40 at channel 2422MHz	

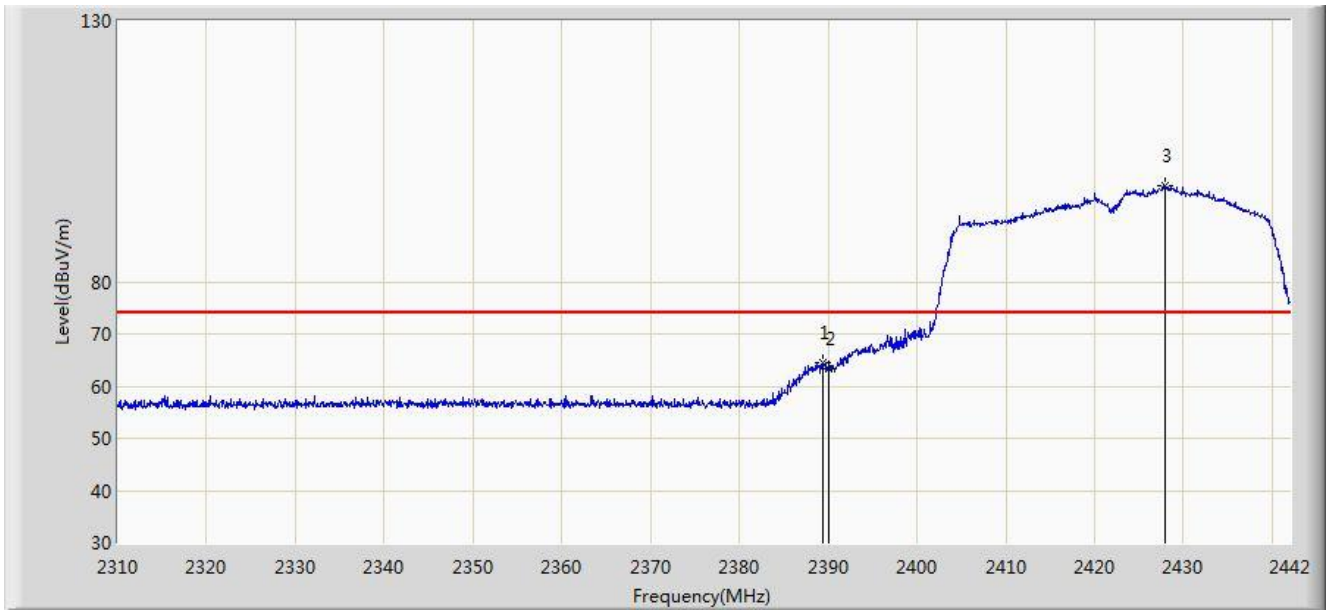

No	Flag	Mark	Frequency (MHz)	Measure Level (dBuV/m)	Reading Level (dBuV)	Over Limit (dB)	Limit (dBuV/m)	Factor (dB)	Type
1			2389.398	64.375	33.171	-9.625	74.000	31.203	PK
2			2390.000	63.271	32.068	-10.729	74.000	31.203	PK
3		*	2428.008	98.377	67.235	N/A	N/A	31.142	PK

Note: Measure Level (dB μ V/m) = Reading Level (dB μ V) + Factor (dB)

Factor (dB) = Cable Loss (dB) + Antenna Factor (dB/m).

Site: AC1	Time: 2017/11/17 - 21:05
Limit: FCC_Part15.209_RE(3m)	Engineer: Will Yan
Probe: BBHA9120D_1-18GHz	Polarity: Horizontal
EUT: Mobile Data Terminal	Power: AC 120V/60Hz
Test Mode: Transmit by 802.11n-HT40 at channel 2422MHz	

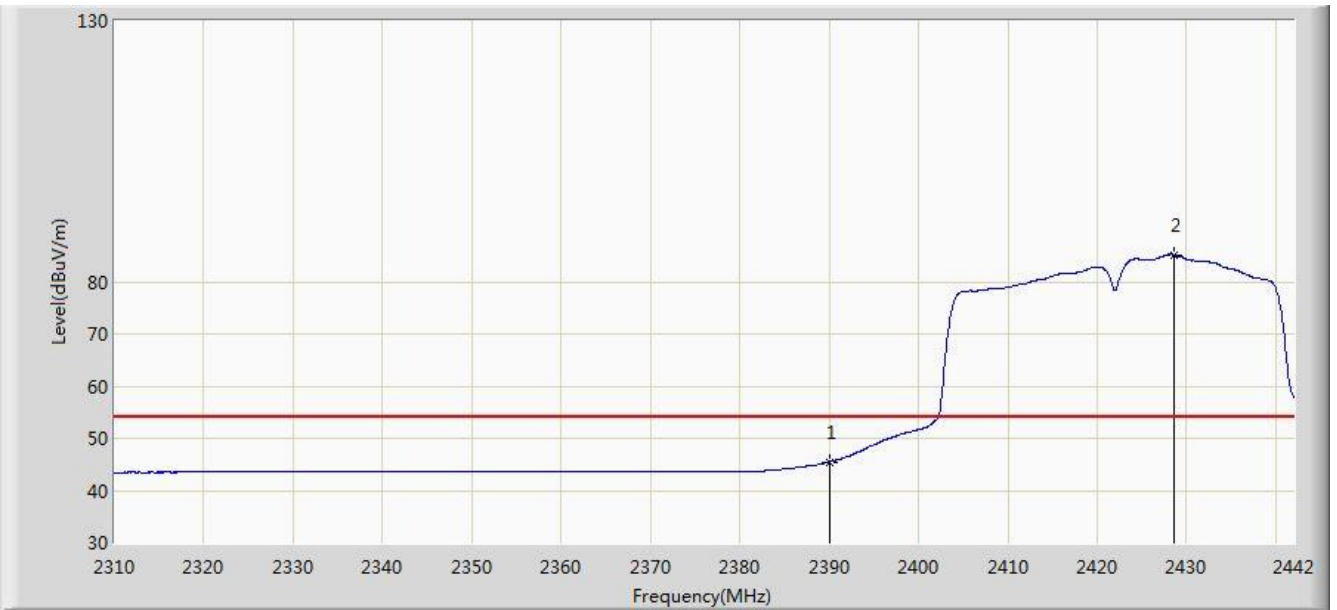

No	Flag	Mark	Frequency (MHz)	Measure Level (dBuV/m)	Reading Level (dBuV)	Over Limit (dB)	Limit (dBuV/m)	Factor (dB)	Type
1			2390.000	45.497	14.294	-8.503	54.000	31.203	AV
2		*	2428.602	85.170	54.029	N/A	N/A	31.141	AV

Note: Measure Level (dBuV/m) = Reading Level (dBuV) + Factor (dB)

Factor (dB) = Cable Loss (dB) + Antenna Factor (dB/m).

Site: AC1	Time: 2017/11/17 - 21:06
Limit: FCC_Part15.209_RE(3m)	Engineer: Will Yan
Probe: BBHA9120D_1-18GHz	Polarity: Vertical
EUT: Mobile Data Terminal	Power: AC 120V/60Hz
Test Mode: Transmit by 802.11n-HT40 at channel 2422MHz	

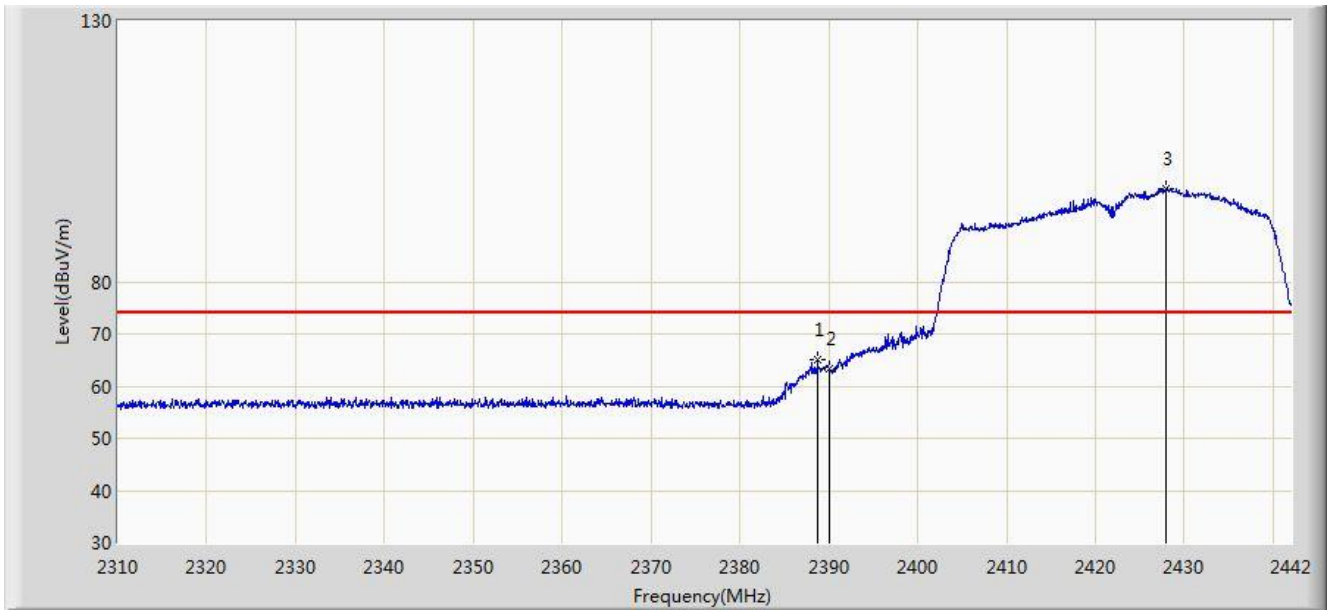

No	Flag	Mark	Frequency (MHz)	Measure Level (dBuV/m)	Reading Level (dBuV)	Over Limit (dB)	Limit (dBuV/m)	Factor (dB)	Type
1			2388.738	64.976	33.771	-9.024	74.000	31.205	PK
2			2390.000	63.338	32.135	-10.662	74.000	31.203	PK
3		*	2427.942	97.912	66.770	N/A	N/A	31.142	PK

Note: Measure Level (dB μ V/m) = Reading Level (dB μ V) + Factor (dB)

Factor (dB) = Cable Loss (dB) + Antenna Factor (dB/m).

Site: AC1	Time: 2017/11/17 - 21:08
Limit: FCC_Part15.209_RE(3m)	Engineer: Will Yan
Probe: BBHA9120D_1-18GHz	Polarity: Vertical
EUT: Mobile Data Terminal	Power: AC 120V/60Hz
Test Mode: Transmit by 802.11n-HT40 at channel 2422MHz	

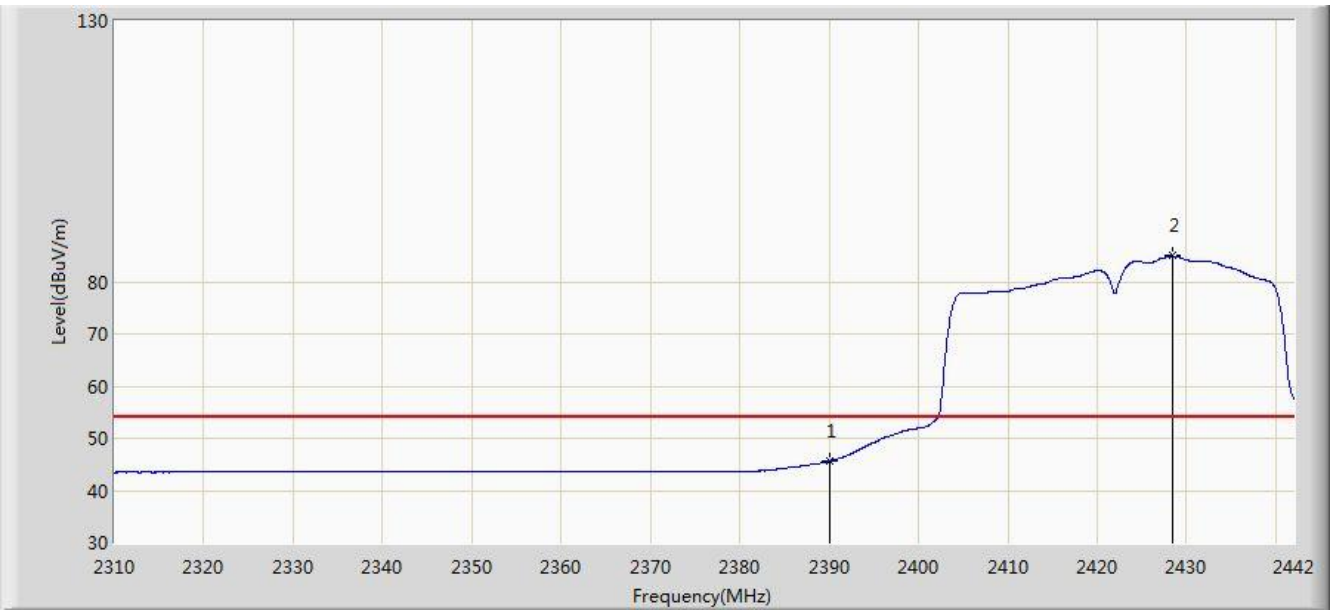

No	Flag	Mark	Frequency (MHz)	Measure Level (dBuV/m)	Reading Level (dBuV)	Over Limit (dB)	Limit (dBuV/m)	Factor (dB)	Type
1			2390.000	45.664	14.461	-8.336	54.000	31.203	AV
2		*	2428.404	84.936	53.795	N/A	N/A	31.141	AV

Note: Measure Level (dBuV/m) = Reading Level (dBuV) + Factor (dB)

Factor (dB) = Cable Loss (dB) + Antenna Factor (dB/m).

Site: AC1	Time: 2017/11/17 - 21:09
Limit: FCC_Part15.209_RE(3m)	Engineer: Will Yan
Probe: BBHA9120D_1-18GHz	Polarity: Horizontal
EUT: Mobile Data Terminal	Power: AC 120V/60Hz
Test Mode: Transmit by 802.11n-HT40 at channel 2452MHz	

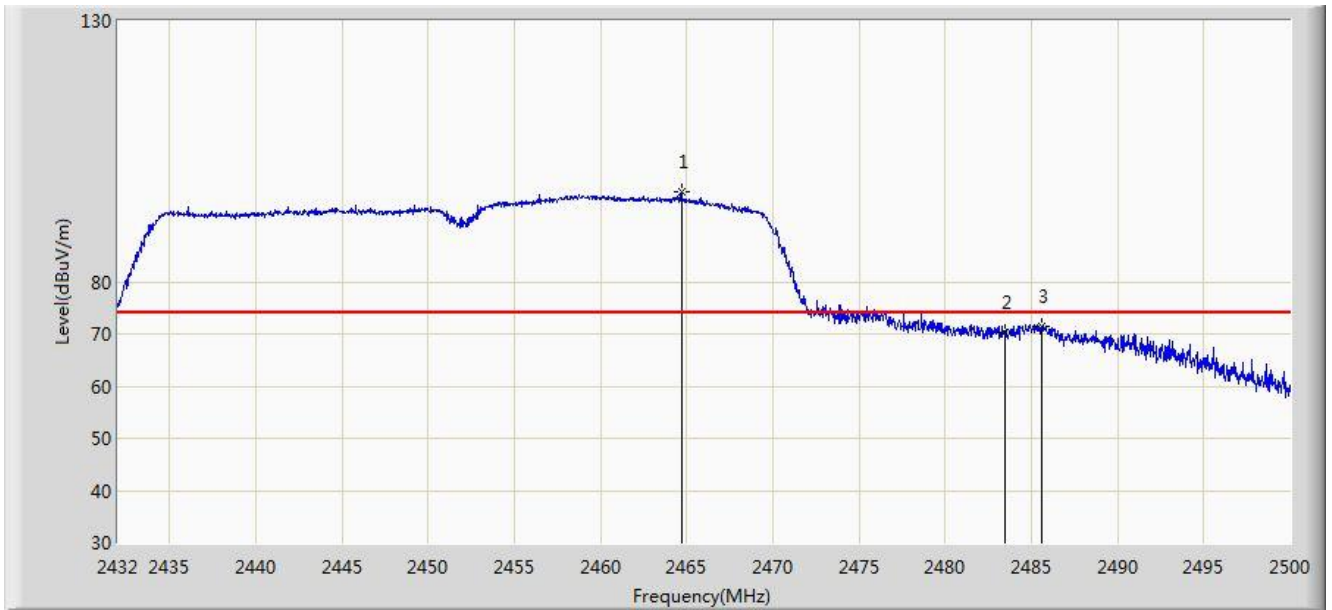

No	Flag	Mark	Frequency (MHz)	Measure Level (dBuV/m)	Reading Level (dBuV)	Over Limit (dB)	Limit (dBuV/m)	Factor (dB)	Type
1		*	2464.708	97.324	66.183	N/A	N/A	31.142	PK
2			2483.500	70.379	39.186	-3.621	74.000	31.194	PK
3			2485.618	71.522	40.323	-2.478	74.000	31.198	PK

Note: Measure Level (dB μ V/m) = Reading Level (dB μ V) + Factor (dB)

Factor (dB) = Cable Loss (dB) + Antenna Factor (dB/m).

Site: AC1	Time: 2017/11/17 - 21:13
Limit: FCC_Part15.209_RE(3m)	Engineer: Will Yan
Probe: BBHA9120D_1-18GHz	Polarity: Horizontal
EUT: Mobile Data Terminal	Power: AC 120V/60Hz
Test Mode: Transmit by 802.11n-HT40 at channel 2452MHz	

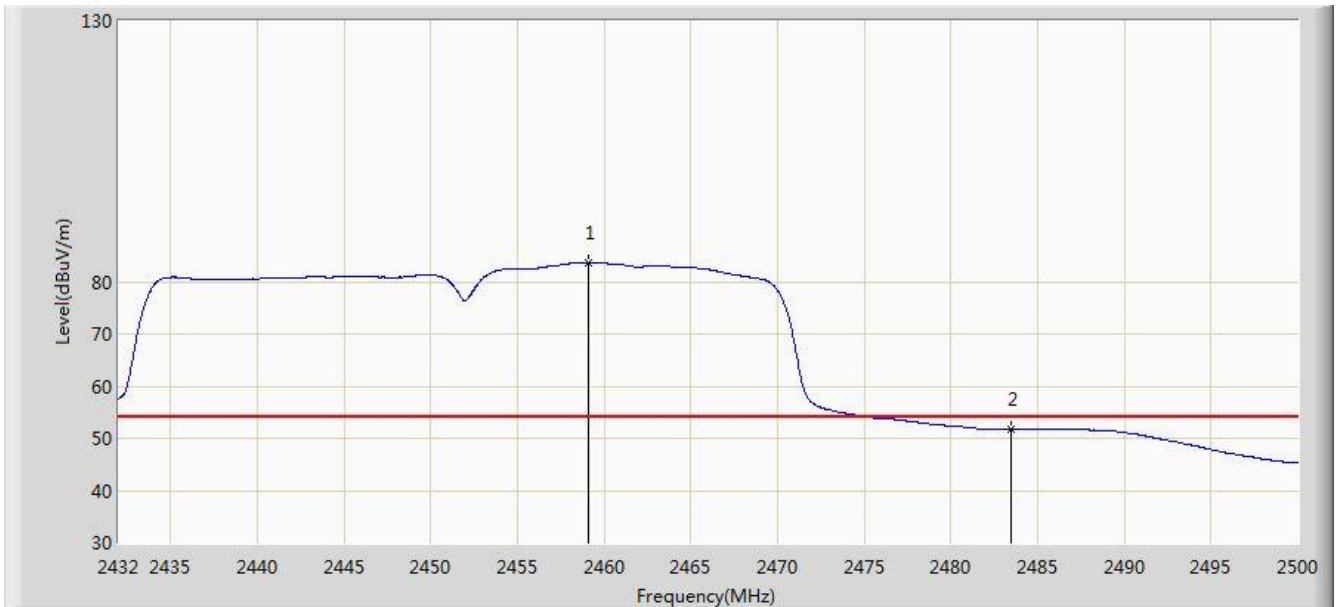

No	Flag	Mark	Frequency (MHz)	Measure Level (dBuV/m)	Reading Level (dBuV)	Over Limit (dB)	Limit (dBuV/m)	Factor (dB)	Type
1		*	2459.132	83.598	52.468	N/A	N/A	31.130	AV
2			2483.500	51.799	20.606	-2.201	54.000	31.194	AV

Note: Measure Level (dBuV/m) = Reading Level (dBuV) + Factor (dB)

Factor (dB) = Cable Loss (dB) + Antenna Factor (dB/m).

Site: AC1	Time: 2017/11/17 - 21:14
Limit: FCC_Part15.209_RE(3m)	Engineer: Will Yan
Probe: BBHA9120D_1-18GHz	Polarity: Vertical
EUT: Mobile Data Terminal	Power: AC 120V/60Hz
Test Mode: Transmit by 802.11n-HT40 at channel 2452MHz	

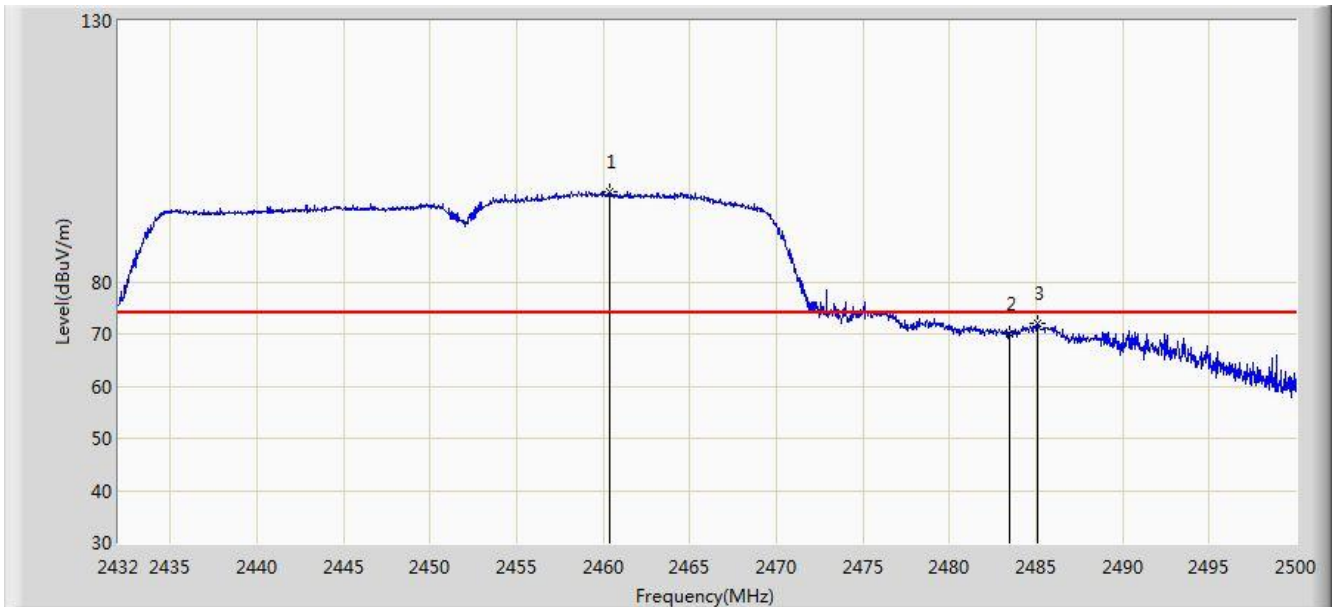

No	Flag	Mark	Frequency (MHz)	Measure Level (dBuV/m)	Reading Level (dBuV)	Over Limit (dB)	Limit (dBuV/m)	Factor (dB)	Type
1		*	2460.356	97.378	66.246	N/A	N/A	31.133	PK
2			2483.500	69.906	38.713	-4.094	74.000	31.194	PK
3			2485.108	71.926	40.728	-2.074	74.000	31.198	PK

Note: Measure Level (dB μ V/m) = Reading Level (dB μ V) + Factor (dB)

Factor (dB) = Cable Loss (dB) + Antenna Factor (dB/m).

Site: AC1	Time: 2017/11/17 - 21:15
Limit: FCC_Part15.209_RE(3m)	Engineer: Will Yan
Probe: BBHA9120D_1-18GHz	Polarity: Vertical
EUT: Mobile Data Terminal	Power: AC 120V/60Hz
Test Mode: Transmit by 802.11n-HT40 at channel 2452MHz	

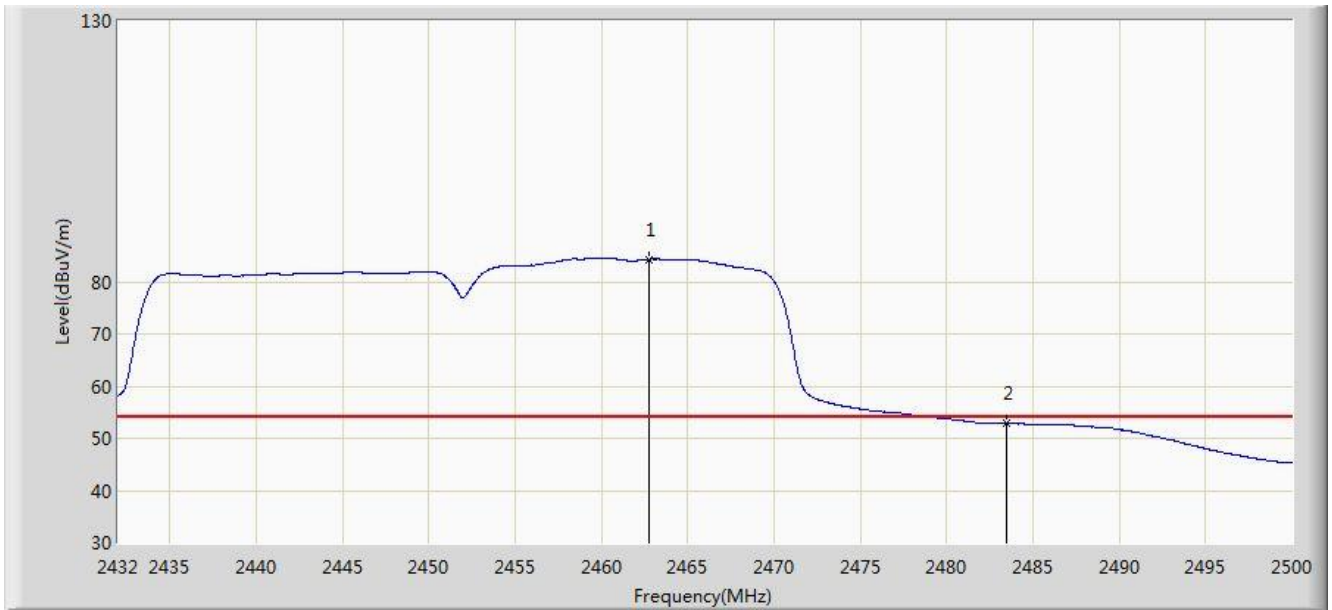

No	Flag	Mark	Frequency (MHz)	Measure Level (dBuV/m)	Reading Level (dBuV)	Over Limit (dB)	Limit (dBuV/m)	Factor (dB)	Type
1		*	2462.736	84.302	53.165	N/A	N/A	31.137	AV
2			2483.500	52.870	21.677	-1.130	54.000	31.194	AV

Note: Measure Level (dB μ V/m) = Reading Level (dB μ V) + Factor (dB)

Factor (dB) = Cable Loss (dB) + Antenna Factor (dB/m).

7.8. AC Conducted Emissions Measurement

7.8.1. Test Limit

FCC Part 15 Subpart C Paragraph 15.207 Limits		
Frequency (MHz)	QP (dBuV)	AV (dBuV)
0.15 - 0.50	66 - 56	56 - 46
0.50 - 5.0	56	46
5.0 - 30	60	50

Note 1: The lower limit shall apply at the transition frequencies.

Note 2: The limit decreases linearly with the logarithm of the frequency in the range 0.15MHz to 0.5MHz.

7.8.2. Test Setup

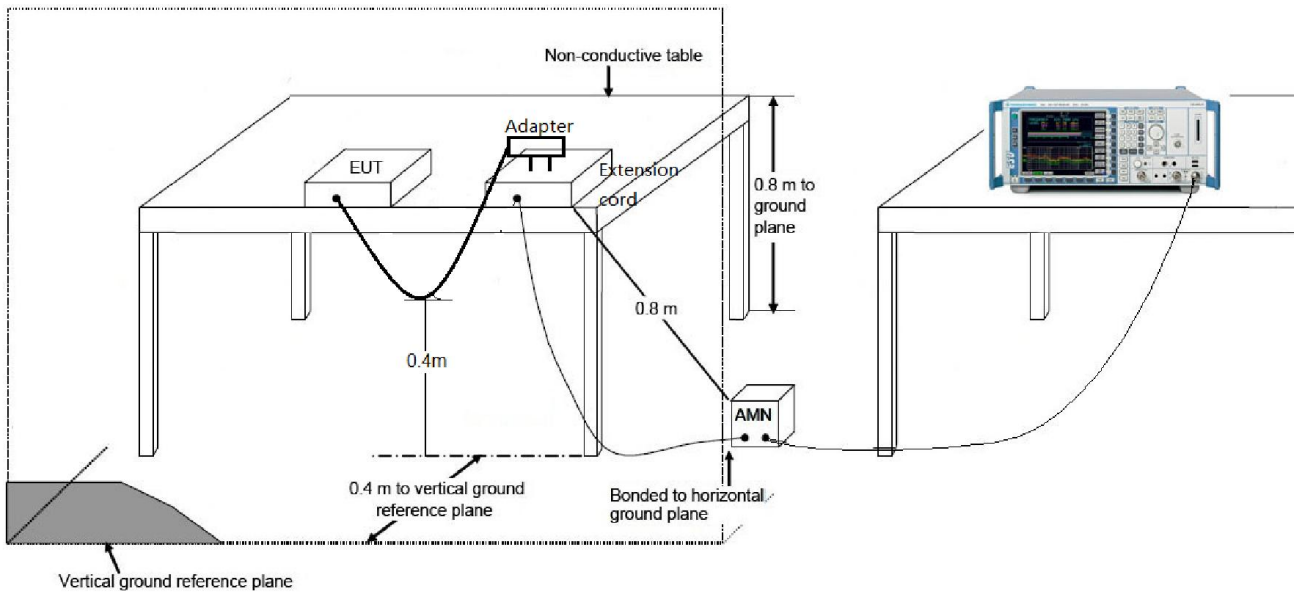

7.8.3. Test Result

Site: SR2	Time: 2017/11/12 - 11:24
Limit: FCC_Part15.207_CE_AC Power	Engineer: Polly Zong
Probe: ENV216_101683_Filter On	Polarity: Line
EUT: Mobile Data Terminal	Power: AC 120V/60Hz
Worst Case Mode: Transmit by 802.11g at Channel 2437MHz	

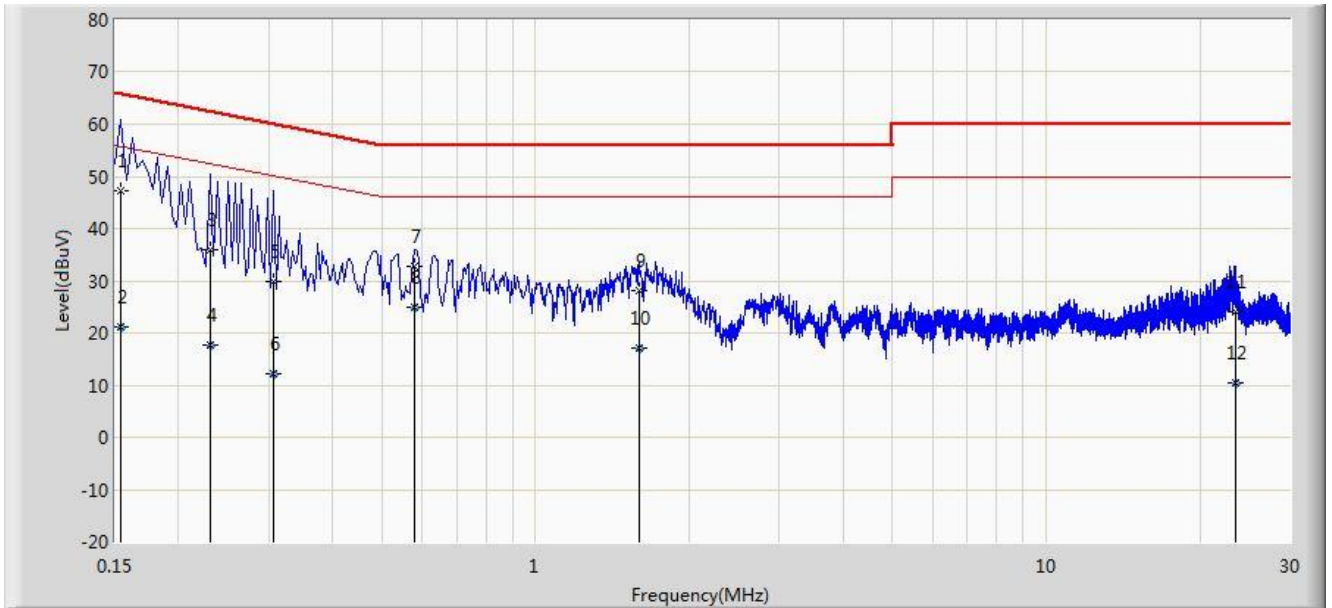

No	Flag	Mark	Frequency (MHz)	Measure Level (dBuV)	Reading Level (dBuV)	Over Limit (dB)	Limit (dBuV)	Factor (dB)	Type
1		*	0.154	47.293	36.553	-18.489	65.781	10.740	QP
2			0.154	21.047	10.308	-34.734	55.781	10.740	AV
3			0.230	36.018	26.070	-26.432	62.450	9.947	QP
4			0.230	17.551	7.604	-34.898	52.450	9.947	AV
5			0.306	29.763	19.754	-30.315	60.078	10.009	QP
6			0.306	12.049	2.040	-38.030	50.078	10.009	AV
7			0.578	32.715	22.589	-23.285	56.000	10.126	QP
8			0.578	24.807	14.681	-21.193	46.000	10.126	AV
9			1.594	28.172	18.286	-27.828	56.000	9.886	QP
10			1.594	16.965	7.079	-29.035	46.000	9.886	AV
11			23.426	24.075	13.894	-35.925	60.000	10.181	QP
12			23.426	10.546	0.365	-39.454	50.000	10.181	AV

Note: Measure Level (dBuV) = Reading Level (dBuV) + Factor (dB)

Factor (dB) = Cable Loss (dB) + LISN Factor (dB)

Site: SR2	Time: 2017/11/12 - 11:28
Limit: FCC_Part15.207_CE_AC Power	Engineer: Polly Zong
Probe: ENV216_101683_Filter On	Polarity: Neutral
EUT: Mobile Data Terminal	Power: AC 120V/60Hz
Worst Case Mode: Transmit by 802.11g at Channel 2437MHz	

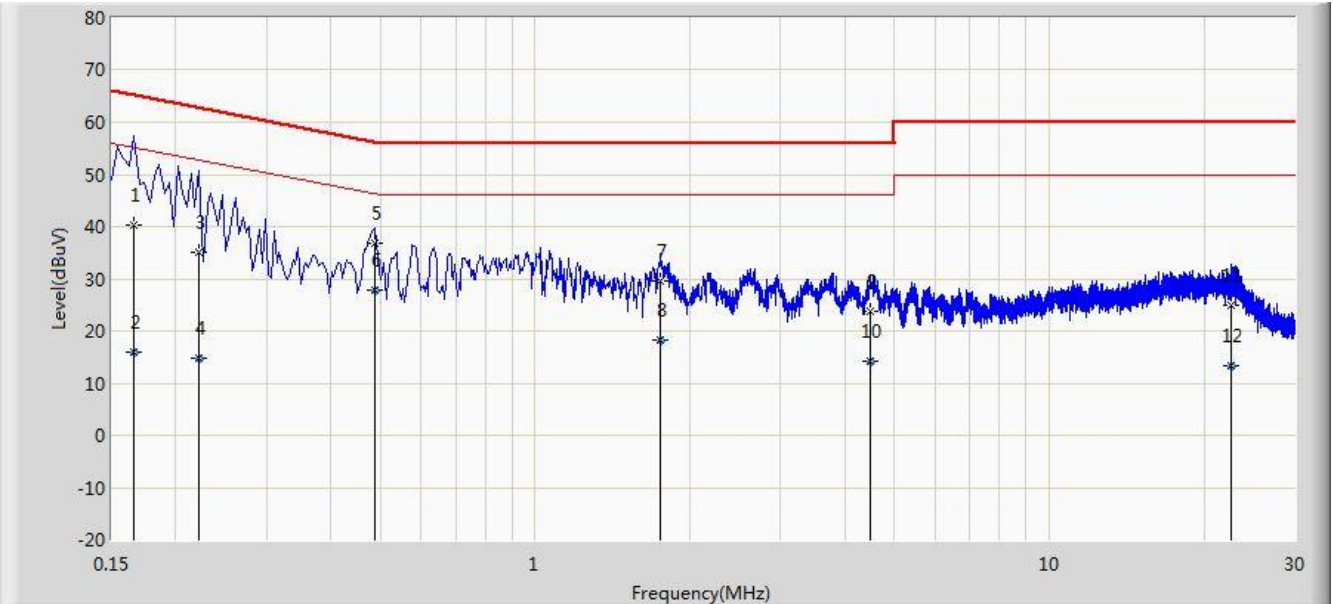

No	Flag	Mark	Frequency (MHz)	Measure Level (dBuV)	Reading Level (dBuV)	Over Limit (dB)	Limit (dBuV)	Factor (dB)	Type
1			0.166	40.355	30.284	-24.803	65.158	10.071	QP
2			0.166	16.048	5.977	-39.110	55.158	10.071	AV
3			0.222	35.021	25.042	-27.722	62.744	9.980	QP
4			0.222	14.883	4.903	-37.861	52.744	9.980	AV
5			0.486	36.803	26.627	-19.432	56.236	10.176	QP
6		*	0.486	27.952	17.776	-18.284	46.236	10.176	AV
7			1.750	29.518	19.636	-26.482	56.000	9.882	QP
8			1.750	18.250	8.368	-27.750	46.000	9.882	AV
9			4.486	23.720	13.721	-32.280	56.000	9.999	QP
10			4.486	14.136	4.138	-31.864	46.000	9.999	AV
11			22.562	24.944	14.709	-35.056	60.000	10.235	QP
12			22.562	13.421	3.186	-36.579	50.000	10.235	AV

Note: Measure Level (dBμV) = Reading Level (dBμV) + Factor (dB)

Factor (dB) = Cable Loss (dB) + LISN Factor (dB)

8. CONCLUSION

The data collected relate only the item(s) tested and show that the **Mobile Data Terminal** is in compliance with Part 15C of the FCC Rules.

————— The End —————