



**Shenzhen Global Test Service Co.,Ltd.**

No.7-101 and 8A-104, Building 7 and 8, DCC Cultural and Creative Garden, No.98, Pingxin North Road, Shangmugu Community, Pinghu Street, Longgang District, Shenzhen, Guangdong

**FCC TEST REPORT**

**FCC Part 22/Part 24**

**Report Reference No.....: GTS20220307015-1-5**

**FCC ID..... : 2AC68-CRUISE2A**

Compiled by  
( position+printed name+signature)..: File administrators Peter Xiao

Supervised by  
( position+printed name+signature)..: Test Engineer Jenny Zeng

Approved by  
( position+printed name+signature)..: Manager Simon Hu

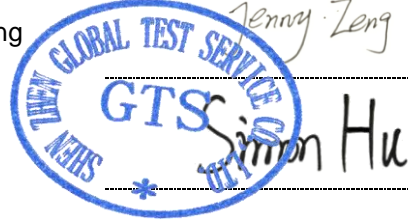

Date of issue.....: Mar. 30, 2022

**Representative Laboratory Name .: Shenzhen Global Test Service Co.,Ltd.**  
Address .....: No.7-101 and 8A-104, Building 7 and 8, DCC Cultural and Creative Garden, No.98, Pingxin North Road, Shangmugu Community, Pinghu Street, Longgang District, Shenzhen, Guangdong

**Applicant's name .....: SEUIC Technologies Co., Ltd.**  
Address .....: NO.15 Xinghuo Road, Nanjing New & High Technology Industry Development Zone, Nanjing, China, 210061

**Test specification .....:**  
Standard .....: **FCC CFR Title 47 Part 2, Part 22H, Part 24E**  
**TIA-603-E March 2016**  
TRF Originator.....: Shenzhen Global Test Service Co.,Ltd..

**Shenzhen Global Test Service Co.,Ltd. All rights reserved.**  
This publication may be reproduced in whole or in part for non-commercial purposes as long as the Shenzhen Global Test Service Co.,Ltd. is acknowledged as copyright owner and source of the material. Shenzhen Global Test Service Co.,Ltd. takes no responsibility for and will not assume liability for damages resulting from the reader's interpretation of the reproduced material due to its placement and context.

**Test item description .....: Portable Data Collection Terminal**  
Trade Mark .....: N/A  
Manufacturer .....: SEUIC Technologies Co., Ltd.  
Model/Type reference.....: CRUISE2A  
Listed Models .....: CRUISE2  
Modulation Type .....: GMSK for GSM/GPRS; GMSK/8PSK for EGPRS  
Hardware Version .....: MC561\_MB\_V1.02  
Software Version .....: D730\_V0.1.7  
Rating .....: DC 3.85V by battery  
Recharged by DC 9.0V  
Result.....: **PASS**

**TEST REPORT**

<b>Test Report No. :</b>	<b>GTS20220307015-1-5</b>	Mar. 30, 2022
		Date of issue

Equipment under Test : Portable Data Collection Terminal

Model /Type : CRUISE2A

Listed model : CRUISE2

**Applicant** : **SEUIC Technologies Co., Ltd.**

Address : NO.15 Xinghuo Road, Nanjing New & High Technology Industry Development Zone, Nanjing, China, 210061

**Manufacturer** : **SEUIC Technologies Co., Ltd.**

Address : NO.15 Xinghuo Road, Nanjing New & High Technology Industry Development Zone, Nanjing, China, 210061

<b>Test result</b>	<b>Pass *</b>
--------------------	---------------

\* In the configuration tested, the EUT complied with the standards specified page 4.

The test report merely corresponds to the test sample.  
It is not permitted to copy extracts of these test result without the written permission of the test laboratory.

## Contents

<b>1 SUMMARY .....</b>	<b>4</b>
1.1 TEST STANDARDS .....	4
<b>2 GENERAL INFORMATION.....</b>	<b>5</b>
2.1 General Remarks .....	5
2.2 Product Description .....	5
2.3 Equipment Under Test .....	7
2.4 Short description of the Equipment under Test (EUT) .....	7
2.5 Environmental conditions .....	7
2.6 Description of Test Modes .....	7
2.7 Block Diagram of Test Setup .....	7
2.8 Special Accessories .....	7
2.9 Related Submittal(s) / Grant (s) .....	7
2.10 Modifications .....	7
<b>3 TEST ENVIRONMENT .....</b>	<b>8</b>
3.1 Address of the test laboratory .....	8
3.2 Test Facility .....	8
3.3 Environmental conditions .....	8
3.4 Statement of the measurement uncertainty .....	8
3.5 Test Description .....	9
3.6 Equipments Used during the Test.....	10
<b>4 TEST CONDITIONS AND RESULTS .....</b>	<b>11</b>
4.1 Output Power .....	11
4.2 Peak-to-Average Ratio (PAR) .....	14
4.3 Occupied Bandwidth and Emission Bandwidth.....	17
4.4 Band Edge compliance .....	20
4.5 Spurious Emission.....	23
4.6 Frequency Stability under Temperature & Voltage Variations .....	35
<b>5 TEST SETUP PHOTOS OF THE EUT.....</b>	<b>37</b>
<b>6 EXTERNAL AND INTERNAL PHOTOS OF THE EUT .....</b>	<b>38</b>

# **1 SUMMARY**

## **1.1 TEST STANDARDS**

The tests were performed according to following standards:

[FCC Part 22](#) : PUBLIC MOBILE SERVICES

[FCC Part 24](#) : PERSONAL COMMUNICATIONS SERVICES

[TIA-603-E March 2016](#): Land Mobile FM or PM Communications Equipment Measurement and Performance Standards.

[FCC Part 2](#): FREQUENCY ALLOCATIONS AND RADIO TREATY MATTERS; GENERAL RULES AND REGULATIONS

[FCC KDB971168 D01](#) Power Meas License Digital Systems v03r01

[ANSI C63.26:2015](#):American National Standard for Compliance Testing of Transmitters Used in Licensed Radio Services

## 2 GENERAL INFORMATION

### 2.1 General Remarks

Date of receipt of test sample	:	Mar. 09, 2022
Testing commenced on	:	Mar. 09, 2022
Testing concluded on	:	Mar. 30, 2022

### 2.2 Product Description

Product Name	Portable Data Collection Terminal
Trade Mark	N/A
Model/Type reference	CRUISE2A
List Models	CRUISE2
Model Declaration	PCB board, structure and internal of these model(s) are the same, Only the model name different , So no additional models were tested.
Power supply:	DC 3.85V by battery Recharged by DC 9.0V
Sample ID	GTS20220307015-1-1# & GTS20220307015-1-2#
<b>Bluetooth</b>	
Operation frequency	2402-2480MHz
Channel Number	79 channels for Bluetooth (DSS) 40 channels for Bluetooth (DTS)
Channel Spacing	1MHz for Bluetooth (DSS) 2MHz for Bluetooth (DTS)
Modulation Type	GFSK, $\pi/4$ -DQPSK, 8DPSK for Bluetooth (DSS) GFSK for Bluetooth (DTS)
<b>WIFI(2.4G Band)</b>	
Frequency Range	2412MHz ~ 2462MHz
Channel Spacing	5MHz
Channel Number	11 Channel for 20MHz bandwidth(2412~2462MHz) 7 Channel for 40MHz bandwidth(2422~2452MHz)
Modulation Type	802.11b: DSSS(CCK,DQPSK,DBPSK); 802.11g/n: OFDM(64QAM, 16QAM, QPSK, BPSK)
<b>WIFI(5.2G Band)</b>	
Frequency Range	5180MHz ~ 5240MHz, 5260MHz ~ 5320MHz, 5500MHz ~ 5700MHz
Channel Number	4 Channels for 20MHz bandwidth(5180-5240MHz) 4 Channels for 20MHz bandwidth(5260-5320MHz) 11 Channels for 20MHz bandwidth(5500-5700MHz) 2 channels for 40MHz bandwidth(5190~5230MHz) 2 channels for 40MHz bandwidth(5270~5310MHz) 5 Channels for 40MHz bandwidth(5510-5670MHz) 1 channels for 80MHz bandwidth(5210MHz) 1 channels for 80MHz bandwidth(5290MHz) 2 Channels for 80MHz bandwidth(5530-5610MHz)
Modulation Type	802.11a/n/ac: OFDM(256QAM,64QAM, 16QAM, QPSK, BPSK)
<b>WIFI (5.8G Band)</b>	
Frequency Range	5745MHz ~ 5825MHz
Channel Number	5 channels for 20MHz bandwidth(5745-5825MHz) 2 channels for 40MHz bandwidth(5755~5795MHz) 1 channels for 80MHz bandwidth(5775MHz)
Modulation Type	802.11a/n/ac: OFDM(256QAM,64QAM, 16QAM, QPSK, BPSK)
Antenna Description	Internal Antenna, -1dBi(Max.) for 2.4G Band and 5G Band
<b>2G</b>	
Support Band	GSM850/GSM1900/GPRS850/GPRS1900/EDGE850/EDGE1900

Release Version	R99
GPRS Class	Class 12
EGPRS Class	Class 12
GSM/EDGE/GPRS Power Class	GSM850:Power Class 4/ PCS1900:Power Class 1
GPRS/EDGE Multislot Class	GPRS/EDGE: Multi-slot Class 12
Type Of Modulation	GMSK for GSM/GPRS; GMSK/8PSK for EGPRS
Antenna Description	Internal Antenna; 2.52dBi (max.) For GSM 850, DCS 1900
<b>3G</b>	
UMTS Operation Frequency Band	UMTS FDD Band 2(1850 MHz -1910MHz) UMTS FDD Band 4(1710 MHz -1755MHz) UMTS FDD Band 5(824 MHz -849MHz)
WCDMA Release Version	R8
HSDPA Release Version	Release 8
HSUPA Release Version	Release 8
Modulation Type	QPSK/16QAM
Antenna Description	Internal Antenna; 2.52dBi (max.) For WCDMA Band 2, 4, 5;
<b>LTE</b>	
LTE Operation Frequency Band	E-UTRA Band 2(1850 MHz -1910MHz) E-UTRA Band 4(1710 MHz -1755MHz) E-UTRA Band 5(824 MHz -849MHz) E-UTRA Band 7(2500 MHz -2570MHz) E-UTRA Band 12(699 MHz -716MHz) E-UTRA Band 13(777 MHz -787MHz) E-UTRA Band 17(704 MHz -716MHz) E-UTRA Band 25(1850 MHz -1915MHz) E-UTRA Band 26(814 MHz -824MHz) E-UTRA Band 26(824 MHz -849MHz) E-UTRA Band 38(2570 MHz -2620MHz) E-UTRA Band 41(2555 MHz -2655MHz) E-UTRA Band 66(1710 MHz -1780MHz)
LTE Release Version	R10
Type Of Modulation	QPSK/16QAM/64QAM
Antenna Description	Internal Antenna; 2.52dBi (max.) For LTE Band 2, 4, 5, 7, 12, 13, 17, 25, 26, 38, 41, 66;
<b>RFID(13.56MHz) (Optional)</b>	
Frequency Range	13.56MHz
Channel Number	1
Modulation Type	ASK
Antenna Description	Internal Antenna, 0dBi (Max.)
GPS(RX)	Support

### 2.3 Equipment Under Test

#### Power supply system utilised

Power supply voltage	:	<input type="radio"/> 230V / 50 Hz	<input type="radio"/> 120V / 60Hz
		<input type="radio"/> 12 V DC	<input type="radio"/> 24 V DC
		<input checked="" type="radio"/> Other (specified in blank below)	

DC 3.85V

### 2.4 Short description of the Equipment under Test (EUT)

This is a Portable Data Collection Terminal .For more details, refer to the user’s manual of the EUT.

### 2.5 Environmental conditions

During the measurement the environmental conditions were within the listed ranges:

Normal Temperature:	25°C
Relative Humidity:	55 %
Air Pressure:	101 kPa

### 2.6 Description of Test Modes

The EUT has been tested under typical operating condition. The CMW500 used to control the EUT staying in continuous transmitting and receiving mode for testing. Regards to the frequency band operation: the lowest, middle and highest frequency of channel were selected to perform the test, then shown on this report.

Note:

1. For the ERP/EIRP and radiated emission test, every axis (X, Y, Z) was verified, and show the worst resulton this report.
2. Test method and refer to 3GPP TS151010.

### 2.7 Block Diagram of Test Setup

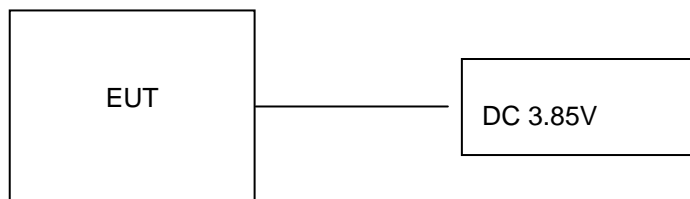

### 2.8 Special Accessories

Manufacturer	Description	Model	Serial Number	Certificate
Shenzhen Tianyin Electronics Co., Ltd.	Adapter	TPA-10R120150UU01	--	SDOC

### 2.9 Related Submittal(s) / Grant (s)

This submittal(s) (test report) is filing to comply with of the FCC Part 22,Part 24 Rules.

### 2.10 Modifications

No modifications were implemented to meet testing criteria.

### 3 TEST ENVIRONMENT

#### 3.1 Address of the test laboratory

##### Shenzhen Global Test Service Co.,Ltd.

No.7-101 and 8A-104, Building 7 and 8, DCC Cultural and Creative Garden, No.98, Pingxin North Road, Shangmugu Community, Pinghu Street, Longgang District, Shenzhen, Guangdong,China.

The sites are constructed in conformance with the requirements of ANSI C63.4 (2014) and CISPR Publication 22.

#### 3.2 Test Facility

The test facility is recognized, certified, or accredited by the following organizations:

CNAS (No. CNAS L8169)

Shenzhen Global Test Service Co., Ltd. has been assessed and proved to be in compliance with CNAS-CL01 Accreditation Criteria for Testing and Calibration Laboratories (identical to ISO/IEC 17025: 2019 General Requirements) for the Competence of Testing and Calibration Laboratories.

A2LA (Certificate No. 4758.01)

Shenzhen Global Test Service Co., Ltd. has been assessed by the American Association for Laboratory Accreditation (A2LA). Certificate No. 4758.01.

Industry Canada Registration Number. is 24189.

FCC Designation Number is CN1234.

FCC Registered Test Site Number is165725.

#### 3.3 Environmental conditions

During the measurement the environmental conditions were within the listed ranges:

Temperature:	15-35 ° C
Humidity:	30-60 %
Atmospheric pressure:	950-1050mbar

#### 3.4 Statement of the measurement uncertainty

The data and results referenced in this document are true and accurate. The reader is cautioned that there may be errors within the calibration limits of the equipment and facilities. The measurement uncertainty was calculated for all measurements listed in this test report acc. to CISPR 16 - 4 „Specification for radio disturbance and immunity measuring apparatus and methods – Part 4: Uncertainty in EMC Measurements“ and is documented in the Shenzhen Global Test Service Co.,Ltd quality system acc. to DIN EN ISO/IEC 17025. Furthermore, component and process variability of devices similar to that tested may result in additional deviation. The manufacturer has the sole responsibility of continued compliance of the device.

Hereafter the best measurement capability for Shenzhen GTS laboratory is reported:

Test	Range	Measurement Uncertainty	Notes
Radiated Emission	30~1000MHz	4.10 dB	(1)
Radiated Emission	1~18GHz	4.32 dB	(1)
Radiated Emission	18-40GHz	5.54 dB	(1)
Conducted Disturbance	0.15~30MHz	3.12 dB	(1)

This uncertainty represents an expanded uncertainty expressed at approximately the 95% confidence level using a coverage factor of k=2.



### 3.5 Test Description

Test Item	Section in CFR 47	Test Sample	Result
RF Output Power	Part 2.1046 Part 22.913(a) Part 24.232(c)	GTS20220307015-1-1#	Pass
Peak-to-Average Ratio	Part 2.1046 Part 24.232	GTS20220307015-1-1#	Pass
99% & -26 dB Occupied Bandwidth	Part 2.1049	GTS20220307015-1-1#	Pass
Spurious Emissions at Antenna Terminal	Part 2.1051 Part 22.917 Part 24.238	GTS20220307015-1-1#	Pass
Field Strength of Spurious Radiation	Part 2.1053 Part 22.917(b) Part 24.238	GTS20220307015-1-1#	Pass
Out of band emission, Band Edge	Part 2.1051 Part 22.917(b) Part 24.238	GTS20220307015-1-1#	Pass
Frequency stability	Part 2.1055 Part 22.355 Part 24.235	GTS20220307015-1-1#	Pass

Remark:

1. The measurement uncertainty is not included in the test result.
2. NA = Not Applicable; NP = Not Performed
3. Note 1 – Test results inside test report;
4. Note 2 – Test results in other test report (SAR Report).
5. We tested all test mode and recorded worst case in report

### 3.6 Equipments Used during the Test

Test Equipment	Manufacturer	Model No.	Serial No.	Calibration Date	Calibration Due Date
LISN	CYBERTEK	EM5040A	E1850400105	2021/07/17	2022/07/16
LISN	R&S	ESH2-Z5	893606/008	2021/07/17	2022/07/16
EMI Test Receiver	R&S	ESPI3	101841-cd	2021/07/17	2022/07/16
EMI Test Receiver	R&S	ESCI7	101102	2021/09/19	2022/09/18
Spectrum Analyzer	Agilent	N9020A	MY48010425	2021/09/19	2022/09/18
Spectrum Analyzer	R&S	FSV40	100019	2021/07/17	2022/07/16
Vector Signal generator	Agilent	N5181A	MY49060502	2021/07/17	2022/07/16
Signal generator	Agilent	N5182A	3610AO1069	2021/09/19	2022/09/18
Climate Chamber	ESPEC	EL-10KA	A20120523	2021/09/19	2022/09/18
Controller	EM Electronics	Controller EM 1000	N/A	N/A	N/A
Horn Antenna	Schwarzbeck	BBHA 9120D	01622	2021/11/07	2022/11/06
Active Loop Antenna	Beijing Da Ze Technology Co.,Ltd.	ZN30900C	15006	2021/10/10	2022/11/09
Bilog Antenna	Schwarzbeck	VULB9163	000976	2021/07/23	2022/07/22
Broadband Horn Antenna	SCHWARZBECK	BBHA 9170	791	2021/11/07	2022/11/06
Amplifier	Schwarzbeck	BBV 9743	#202	2021/08/08	2022/08/07
Amplifier	Schwarzbeck	BBV9179	9719-025	2021/07/17	2022/07/16
Amplifier	EMCI	EMC051845B	980355	2021/07/17	2022/07/16
Temperature/Humidity Meter	Gangxing	CTH-608	02	2021/07/17	2022/07/16
High-Pass Filter	K&L	9SH10-2700/X12750-O/O	KL142031	2021/07/17	2022/07/16
High-Pass Filter	K&L	41H10-1375/U12750-O/O	KL142032	2021/07/17	2022/07/16
RF Cable(below 1GHz)	HUBER+SUHNER	RG214	RE01	2021/07/17	2022/07/16
RF Cable(above 1GHz)	HUBER+SUHNER	RG214	RE02	2021/07/17	2022/07/16
Data acquisition card	Agilent	U2531A	TW53323507	2021/07/17	2022/07/16
Power Sensor	Agilent	U2021XA	MY5365004	2021/07/17	2022/07/16
Test Control Unit	Tonscend	JS0806-1	178060067	2021/07/17	2022/07/16
Automated filter bank	Tonscend	JS0806-F	19F8060177	2021/07/17	2022/07/16
EMI Test Software	Tonscend	JS1120-1	Ver 2.6.8.0518	/	/
Radio Communication Tester	Rohde&Schwarz	CMW500	115406	2021/07/17	2022/07/16
EMI Test Software	Tonscend	JS1120-3	Ver 2.5.77.0418	/	/
EMI Test Software	Tonscend	JS32-CE	Ver 2.5	/	/
EMI Test Software	Tonscend	JS32-RE	Ver 2.5.1.8	/	/

Note: The Cal.Interval was one year.

## 4 TEST CONDITIONS AND RESULTS

### 4.1 Output Power

#### LIMIT

This is the test for the maximum radiated power from the EUT.

Per rule Part 24.232(c) specifies, "Mobile/portable stations are limited to 2 watts e.i.r.p. Peak power" and 24.232(e) specifies that "Peak transmit power must be measured over any interval of continuous transmission using instrumentation calibrated in terms of an rms-equivalent voltage."

Per rule Part 22.913(a) specifies " The ERP of mobile transmitters and auxiliary test transmitters must not exceed 7 Watts."

#### TEST CONFIGURATION

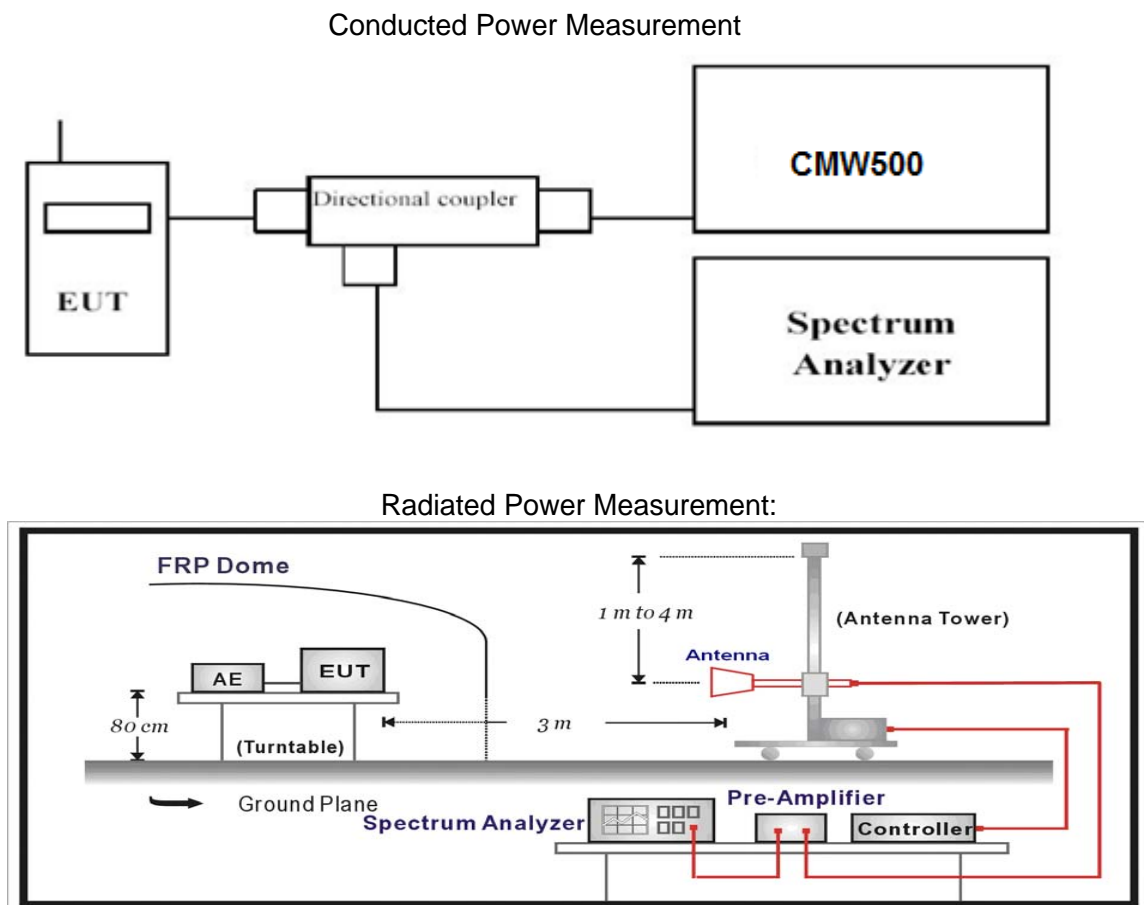

#### TEST PROCEDURE

The EUT was setup according to EIA/TIA 603D

##### **Conducted Power Measurement:**

- Place the EUT on a bench and set it in transmitting mode.
- Connect a low loss RF cable from the antenna port to a spectrum analyzer and CMW500 by a Directional Couple.
- EUT Communicate with CMW500, then select a channel for testing.
- Add a correction factor to the display of spectrum, and then test.

##### **Radiated Power Measurement:**

- The EUT shall be placed at the specified height on a support, and in the position closest to normal use as declared by provider.
- The test antenna shall be oriented initially for vertical polarization and shall be chosen to correspond to the frequency of the transmitter
- The output of the test antenna shall be connected to the measuring receiver.

- d. The transmitter shall be switched on and the measuring receiver shall be tuned to the frequency of the
- e. transmitter under test.
- f. The test antenna shall be raised and lowered through the specified range of height until a maximum signal level is detected by the measuring receiver.
- g. The transmitter shall then be rotated through 360° in the horizontal plane, until the maximum signal level is detected by the measuring receiver.
- h. The test antenna shall be raised and lowered again through the specified range of height until a maximum signal level is detected by the measuring receiver.
- i. The maximum signal level detected by the measuring receiver shall be noted.
- j. The transmitter shall be replaced by a substitution antenna.
- k. The substitution antenna shall be orientated for vertical polarization and the length of the substitution antenna shall be adjusted to correspond to the frequency of the transmitter.
- l. The substitution antenna shall be connected to a calibrated signal generator.
- m. If necessary, the input attenuator setting of the measuring receiver shall be adjusted in order to increase the sensitivity of the measuring receiver.
- n. The test antenna shall be raised and lowered through the specified range of height to ensure that the maximum signal is received.
- o. The input signal to the substitution antenna shall be adjusted to the level that produces a level detected by the measuring receiver, that is equal to the level noted while the transmitter radiated power was measured, corrected for the change of input attenuator setting of the measuring receiver.
- p. The measurement shall be repeated with the test antenna and the substitution antenna orientated for horizontal polarization.
- q. The measure of the effective radiated power is the larger of the two levels recorded at the input to the substitution antenna, corrected for gain of the substitution antenna if necessary.
- r. Test site anechoic chamber refer to ANSI C63.26.

**TEST RESULTS**

Temperature	24.5°C	Humidity	53.7%
Test Engineer	Jenny Zeng	Configurations	GSM

**Conducted Measurement:**

GSM 850		Burst Average Conducted power (dBm)		
		Channel/Frequency(MHz)		
		128/824.2	190/836.6	251/848.8
GSM		32.58	32.24	32.27
GSM(GMSK)	1TX slot	30.65	30.53	30.59
	2TX slot	30.93	30.15	30.99
	3TX slot	29.48	29.74	29.55
	4TX slot	27.45	27.29	27.61
EDGE (8PSK)	1TX slot	25.47	25.37	25.26
	2TX slot	25.44	25.75	25.78
	3TX slot	24.19	24.72	24.12
	4TX slot	22.66	22.94	22.71

GSM 1900		Burst Average Conducted power (dBm)		
		Channel/Frequency(MHz)		
		512/1850.2	661/1880	810/1909.8
GSM		30.54	30.33	30.29
GSM(GMSK)	1TX slot	30.29	30.23	30.18
	2TX slot	29.14	29.40	29.50
	3TX slot	27.91	27.92	27.37
	4TX slot	25.31	25.84	25.55
EDGE (8PSK)	1TX slot	24.97	24.72	24.57
	2TX slot	24.91	24.22	24.71
	3TX slot	23.13	23.27	23.89
	4TX slot	22.96	22.35	22.96

**Radiated Measurement:**

Remark:

1. We were tested all RB Configuration refer 3GPP TS151010 for each Channel Bandwidth of GSM850M,GSM1900M; recorded worst case for each Channel Bandwidth of GSM850M,GSM1900M.
2. ERP = EIRP – 2.15dBi as EIRP by subtracting the gain of the dipole.
3. The unit of Antenna Gain is dBd for frequency below 1GHz, and the unit of Antenna Gain is dBi for frequency above 1GHz.
4. Absolute Level = Substituted Level - Cable loss + Antenna Gain
5. Margin = Limit-Absolute Level

Temperature	24.5°C	Humidity	53.7%
Test Engineer	Jenny Zeng	Configurations	GSM

Frequency (MHz)	Polar (H/V)	Receiver Reading (dBμV)	Substituted Method			Absolute Level (dBm)	Limit (dBm)	Margin (dB)
			Substituted Level (dBm)	Antenna Gain (dBd/dBi)	Cable Loss (dB)			
GSM850 Low Channel								
824.20	H	86.65	22.79	1.65	0.58	23.86	38.45	14.59
824.20	V	85.99	22.03	1.65	0.58	23.10	38.45	16.80
GSM850 Middle Channel								
836.60	H	85.97	22.89	1.59	0.65	23.83	38.45	14.62
836.60	V	86.13	22.16	1.59	0.65	23.10	38.45	16.80
GSM850 High Channel								
848.80	H	86.85	22.97	1.53	0.71	23.79	38.45	14.66
848.80	V	85.75	22.84	1.53	0.71	23.66	38.45	16.80
EDGE 850 Low Channel								
824.200	H	86.90	22.52	1.65	0.58	23.59	38.45	14.86
824.200	V	85.55	22.16	1.65	0.58	23.23	38.45	16.80
EDGE 850 Middle Channel								
836.60	H	86.41	22.38	1.59	0.65	23.32	38.45	15.13
836.60	V	86.01	22.19	1.59	0.65	23.13	38.45	16.80
EDGE 850 High Channel								
848.80	H	85.13	22.05	1.53	0.71	22.87	38.45	15.58
848.80	V	86.05	22.62	1.53	0.71	23.44	38.45	16.80
GSM1900 Low Channel								
1850.20	H	85.47	22.37	1.59	2.11	21.85	33.00	11.15
1850.20	V	86.03	22.84	1.59	2.11	22.32	33.00	16.80
GSM1900 Middle Channel								
1880.00	H	86.56	22.54	1.56	2.14	21.96	33.00	11.04
1880.00	V	84.79	22.61	1.56	2.14	22.03	33.00	16.80
GSM1900 High Channel								
1909.80	H	85.29	22.22	1.52	2.18	21.56	33.00	11.44
1909.80	V	86.13	22.28	1.56	2.18	21.66	33.00	16.80
EDGE 1900 Low Channel								
1850.20	H	83.91	22.59	1.59	2.11	22.07	33.00	10.93
1850.20	V	85.82	22.86	1.59	2.11	22.34	33.00	16.80
EDGE 1900 Middle Channel								
1880.00	H	86.12	22.81	1.56	2.14	22.23	33.00	10.77
1880.00	V	85.80	22.03	1.56	2.14	21.45	33.00	16.80
EDGE 1900 High Channel								
1909.80	H	85.60	22.92	1.52	2.18	22.26	33.00	10.74
1909.80	V	86.53	22.62	1.52	2.18	21.96	33.00	16.80

## 4.2 Peak-to-Average Ratio (PAR)

### LIMIT

The Peak-to-Average Ratio (PAR) of the transmission may not exceed 13 dB.

### TEST CONFIGURATION

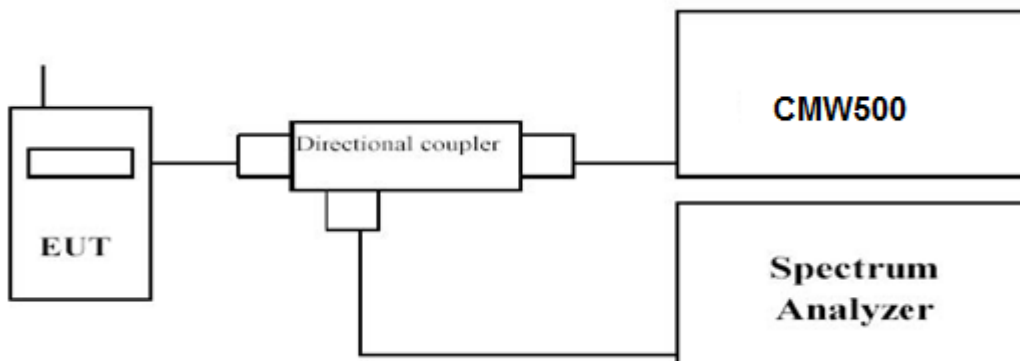

### TEST PROCEDURE

1. Refer to instrument's analyzer instruction manual for details on how to use the power statistics/CCDF function;
2. Set resolution/measurement bandwidth  $\geq$  signal's occupied bandwidth;
3. Set the number of counts to a value that stabilizes the measured CCDF curve;
4. Set the measurement interval as follows:
  - 1). for continuous transmissions, set to 1 ms,
  - 2). for burst transmissions, employ an external trigger that is synchronized with the EUT burst tN/Ag sequence, or use the internal burst trigger with a trigger level that allows the burst to stabilize and set the measurement interval to a time that is less than or equal to the burst duration.
5. Record the maximum PAPR level associated with a probability of 0.1%.

### TEST RESULTS

Temperature	24.5°C	Humidity	53.7%
Test Engineer	Jenny Zeng	Configurations	GSM

Remark:

We were tested all RB Configuration refer 3GPP TS151010 for each Channel Bandwidth of GSM850M,GSM1900M; recorded worst case for each Channel Bandwidth of GSM850, GSM1900M.

### **GSM:**

Test Mode	Channel	Frequency (MHz)	PAPR Value (dB)	Limits (dB)	Verdict
GSM/TM1/GSM850	128	824.2	4.75	13.0	PASS
	190	836.6	4.78	13.0	
	251	848.8	4.81	13.0	
GSM/TM2/EDGE850	128	824.2	6.00	13.0	PASS
	190	836.6	5.07	13.0	
	251	848.8	5.45	13.0	
GSM/TM1/GSM1900	512	1850.2	8.38	13.0	PASS
	661	1880.0	4.99	13.0	
	810	1909.8	4.99	13.0	
GSM/TM2/EDGE1900	512	1850.2	5.83	13.0	PASS
	661	1880.0	4.96	13.0	
	810	1909.8	5.83	13.0	

Peak-to-Average Ratio (PAR)

GSM/TM1/GSM850

GSM/TM2/EDGE850

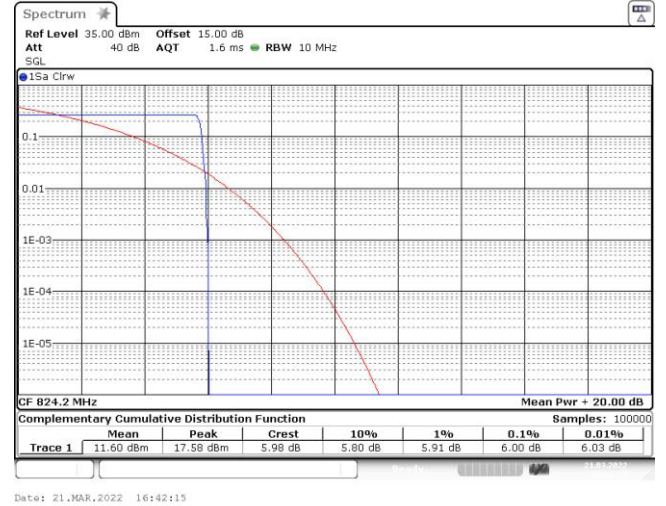
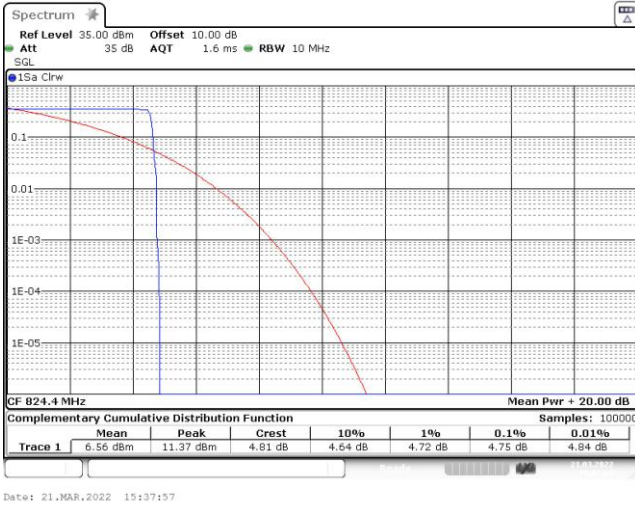

Channel 128/ 824.2 MHz

Channel 128/ 824.2 MHz

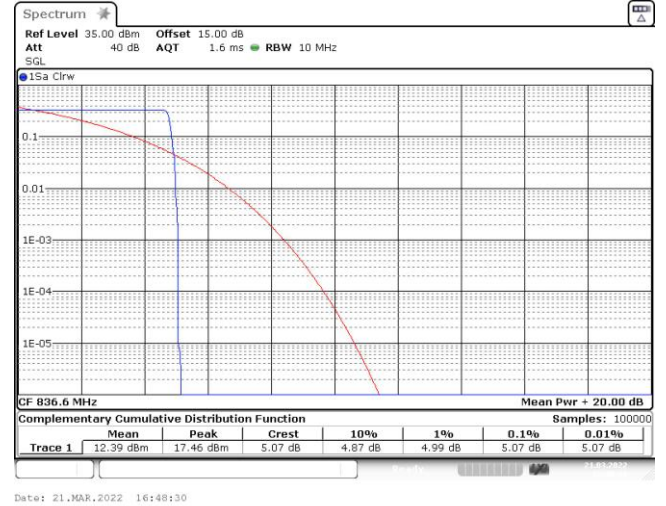
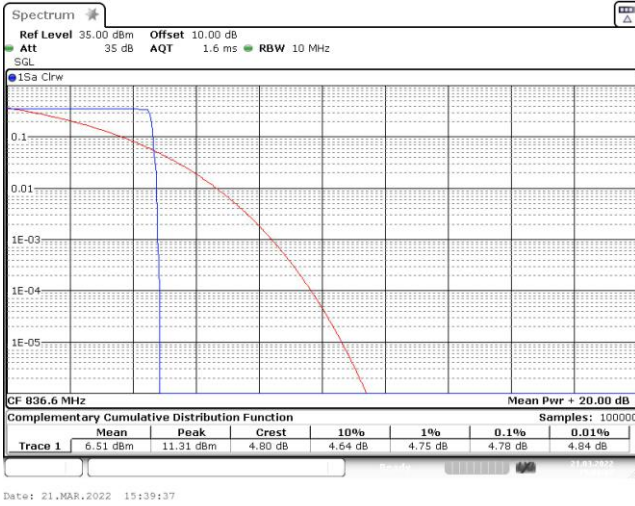

Channel 190/ 836.6 MHz

Channel 190/ 836.6 MHz

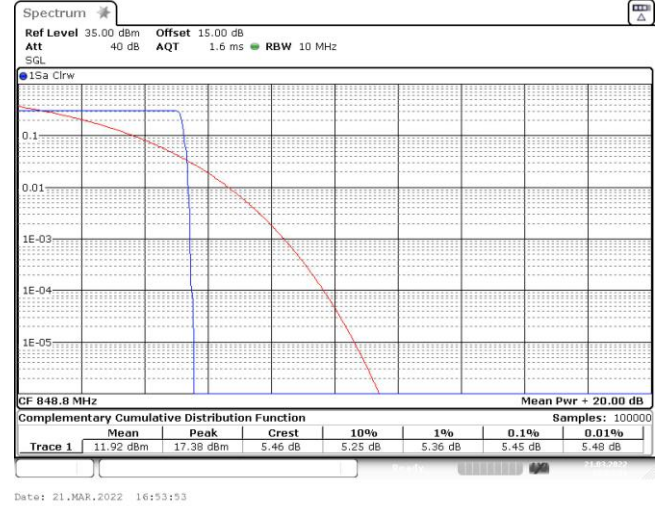
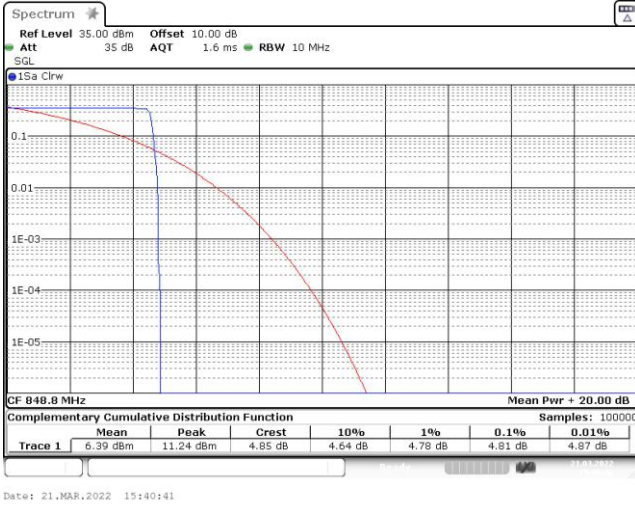

Channel 251/ 848.8 MHz

Channel 251/ 848.8 MHz

Peak-to-Average Ratio (PAR)

GSM/TM1/GSM1900

GSM/TM2/EDGE1900

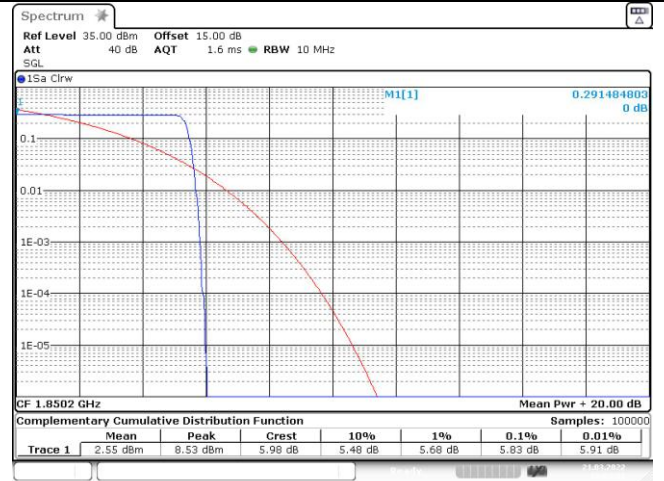
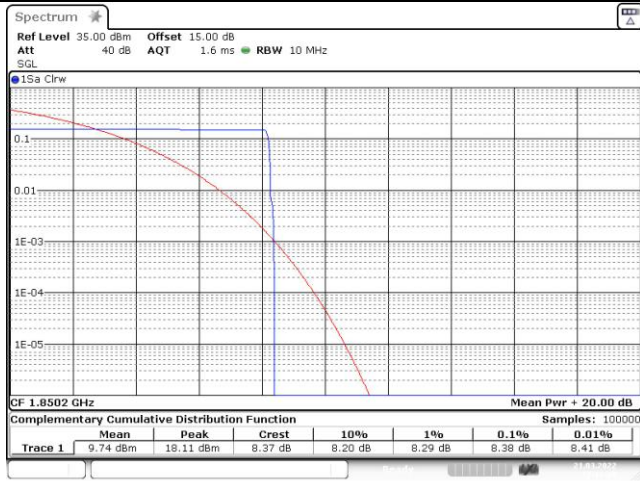

Date: 21.MAR.2022 17:11:28

Date: 21.MAR.2022 17:33:52

Channel 512/ 1850.2 MHz

Channel 512/ 1850.2 MHz

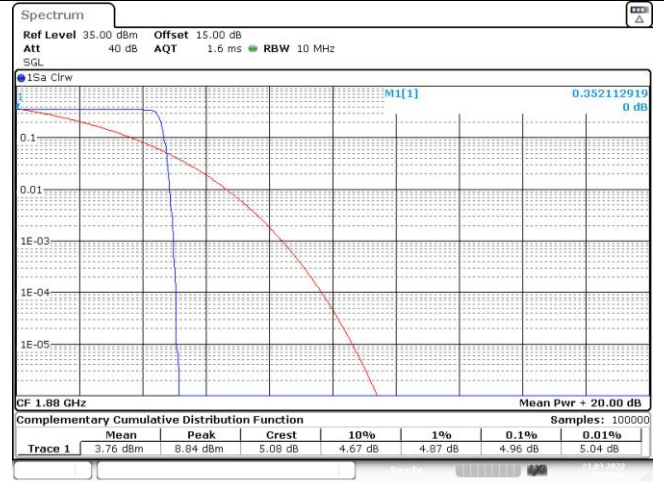
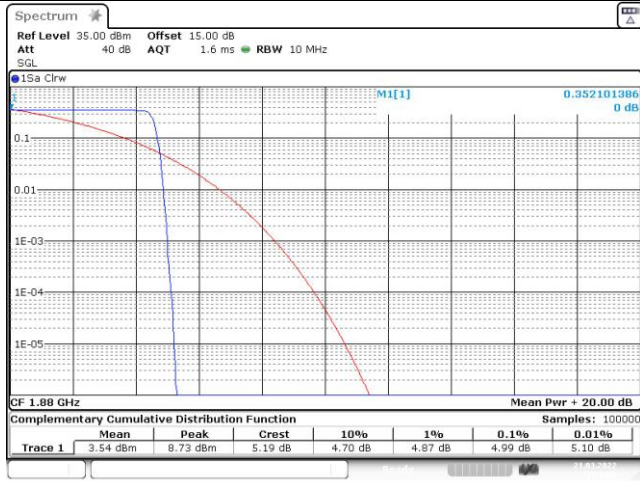

Date: 21.MAR.2022 17:23:16

Date: 21.MAR.2022 17:33:00

Channel 661/ 1880 MHz

Channel 661/ 1880 MHz

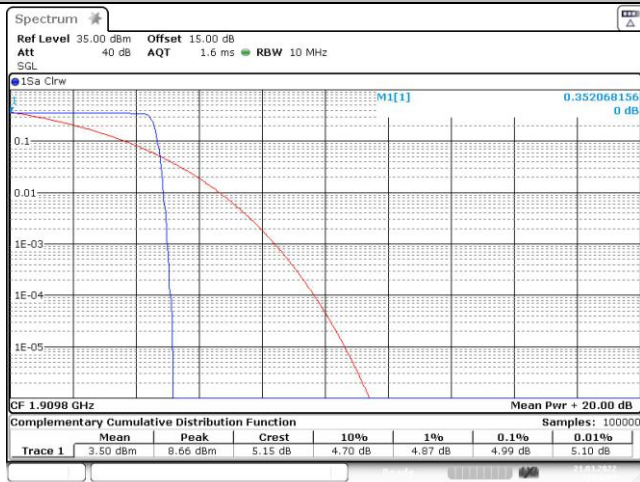

Date: 21.MAR.2022 17:23:08

Date: 21.MAR.2022 17:34:31

Channel 810/ 1909.8 MHz

Channel 810/ 1909.8 MHz

NOTE:We measured all modes and only recorded the worst case.



### 4.3 Occupied Bandwidth and Emission Bandwidth

**LIMIT**

N/A

**TEST CONFIGURATION**

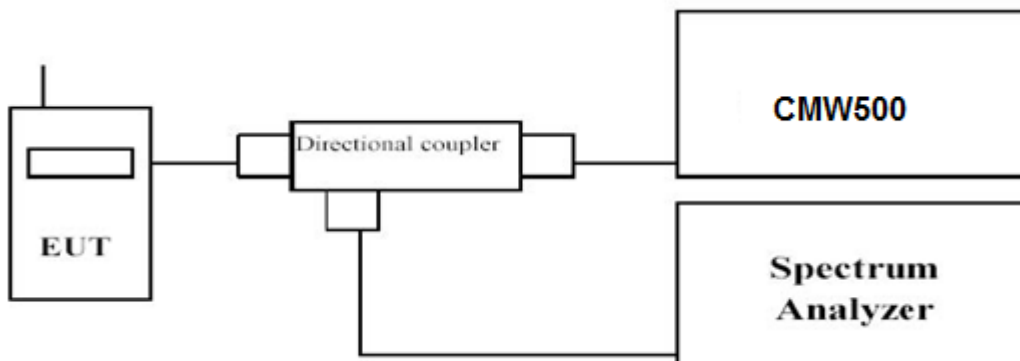

**TEST PROCEDURE**

The transmitter output was connected to a calibrated coaxial cable and coupler, the other end of which was connected to a spectrum analyzer. The occupied bandwidth was measured with the spectrum analyzer at low, middle and high channel in each band. The -26dBc Emission bandwidth was also measured and recorded. Set RBW was set to about 1% of emission BW, VBW≥3 times RBW. -26dBc display line was placed on the screen (or 99% bandwidth), the occupied bandwidth is the delta frequency between the two points where the display line intersects the signal trace.

**TEST RESULTS**

Temperature	24.5°C	Humidity	53.7%
Test Engineer	Jenny Zeng	Configurations	GSM

Remark:

We were tested all RB Configuration refer 3GPP TS151010 for each Channel Bandwidth of GSM850M,GSM1900M; recorded worst case for each Channel Bandwidth of GSM850, GSM1900M.

Test Mode	Channel	Frequency (MHz)	Occupied Bandwidth (99% BW) (KHz)	Emission Bandwidth (-26 dBc BW) (KHz)	Verdict
GSM/TM1 /GSM850	128	824.2	244.47	313.5	PASS
	190	836.6	242.29	309.3	PASS
	251	848.8	241.88	318.7	PASS
GSM/TM2 /EDGE850	128	824.2	243.94	315.0	PASS
	190	836.6	243.45	314.5	PASS
	251	848.8	243.44	318.3	PASS
GSM/TM1 /GSM1900	512	1850.2	240.07	311.0	PASS
	661	1880.0	241.81	311.8	PASS
	810	1909.8	240.57	316.1	PASS
GSM/TM2 /EDGE1900	512	1850.2	242.46	315.2	PASS
	661	1880.0	240.26	316.8	PASS
	810	1909.8	244.32	319.8	PASS

Remark:

1. Test results including cable loss;
2. Please refer to following plots;

Occupied Bandwidth&Emission Bandwidth

GSM/TM1/GSM850

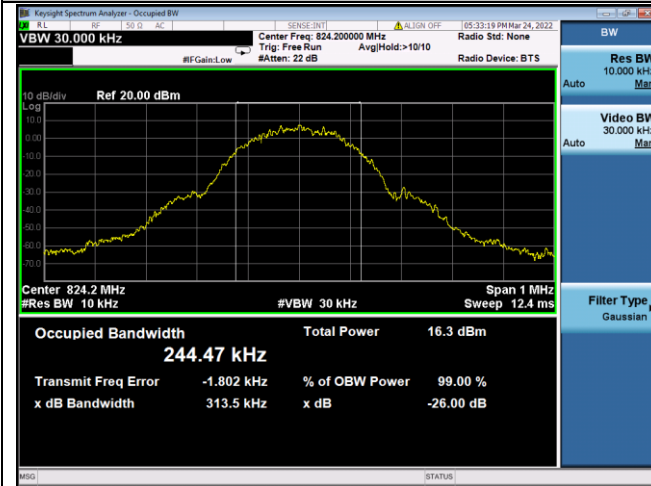

GSM/TM2/EDGE850

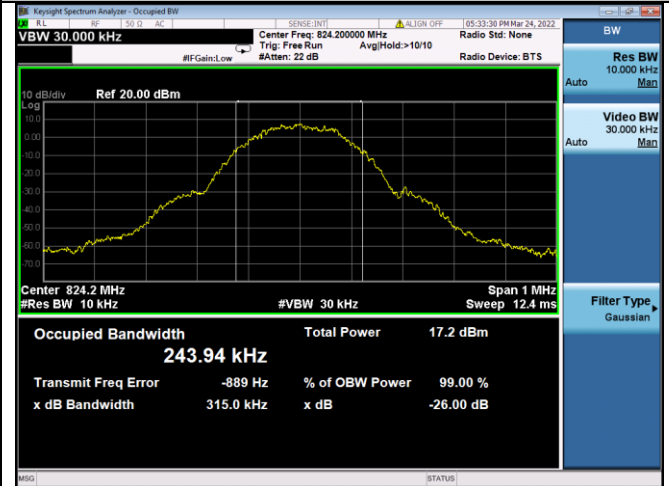

Channel 128 / 824.2 MHz

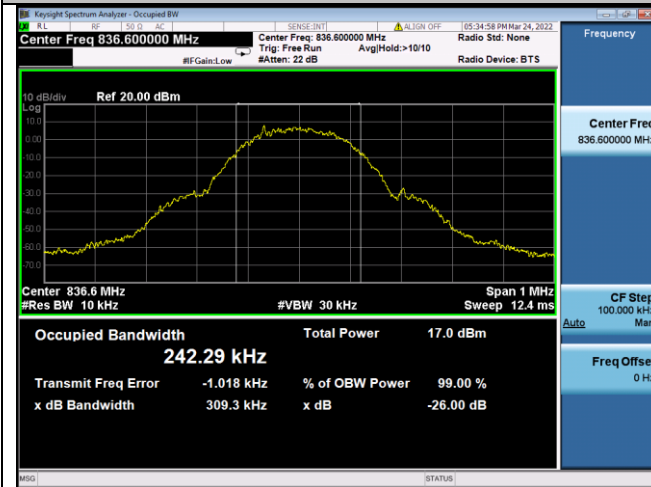

Channel 128 / 824.2 MHz

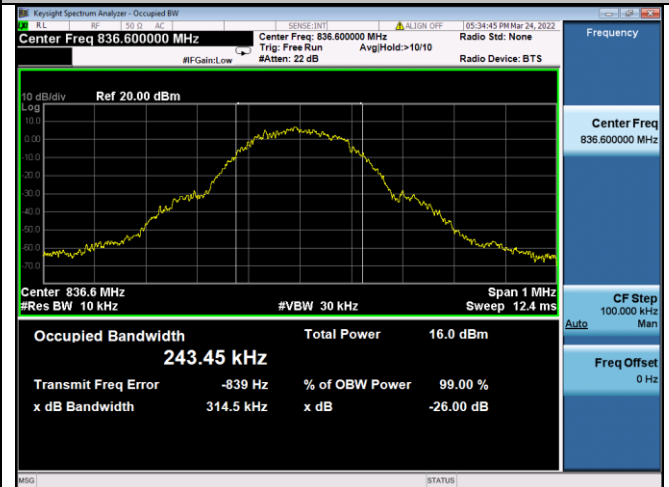

Channel 190 / 836.6 MHz

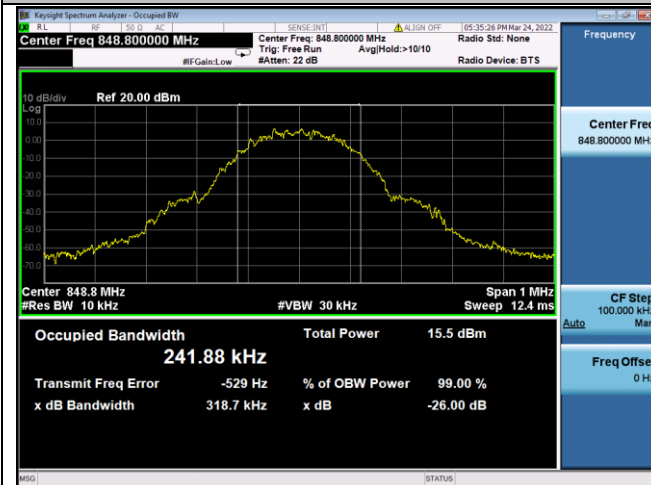

Channel 190 / 836.6 MHz

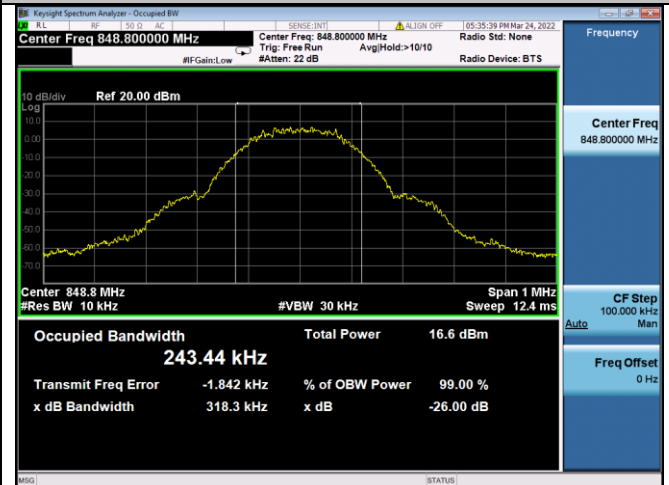

Channel 251 / 848.8 MHz

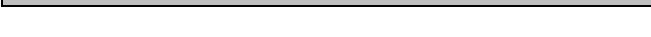

Channel 251 / 848.8 MHz

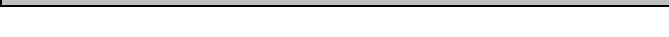

Occupied Bandwidth&Emission Bandwidth

GSM/TM1/GSM1900

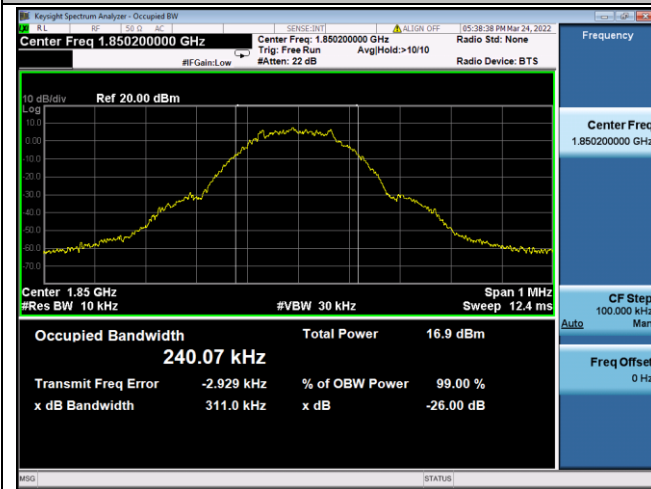

GSM/TM2/ EDGE1900

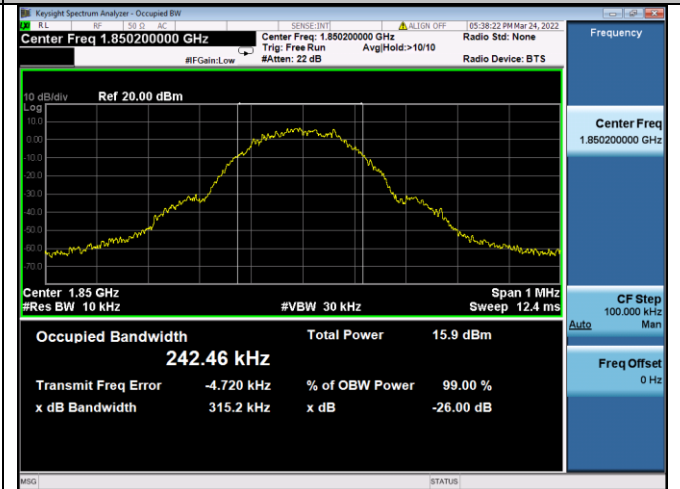

Channel 512 / 1850.2 MHz

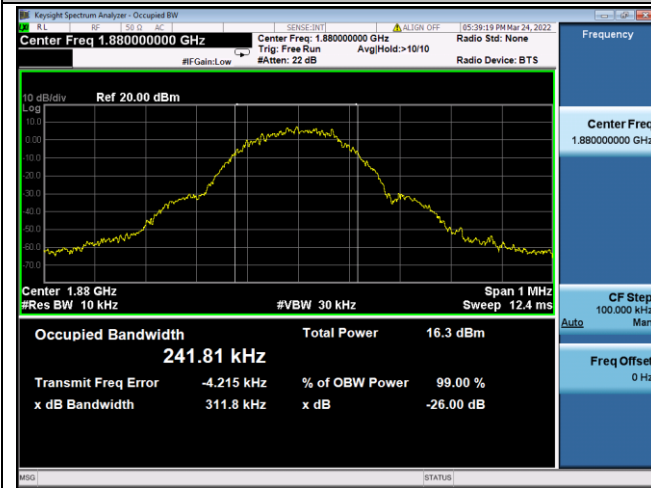

Channel 512 / 1850.2 MHz

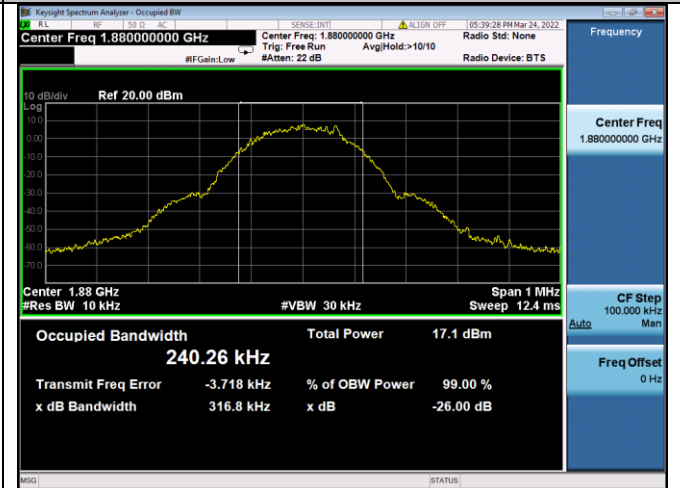

Channel 661 / 1880.0MHz

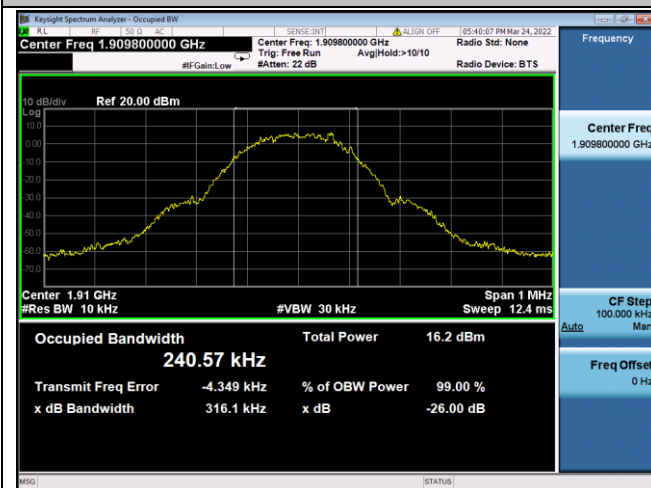

Channel 661 / 1880.0MHz

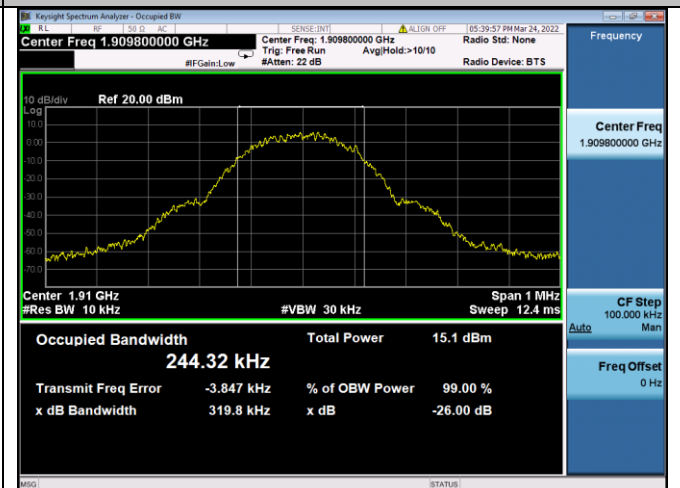

Channel 810 / 1909.8 MHz



Channel 810 / 1909.8 MHz



NOTE:We measured all modes and only recorded the worst case.

### 4.4 Band Edge compliance

#### LIMIT

FCC § 2.1053, §22.917, § 24.238.

#### TEST CONFIGURATION

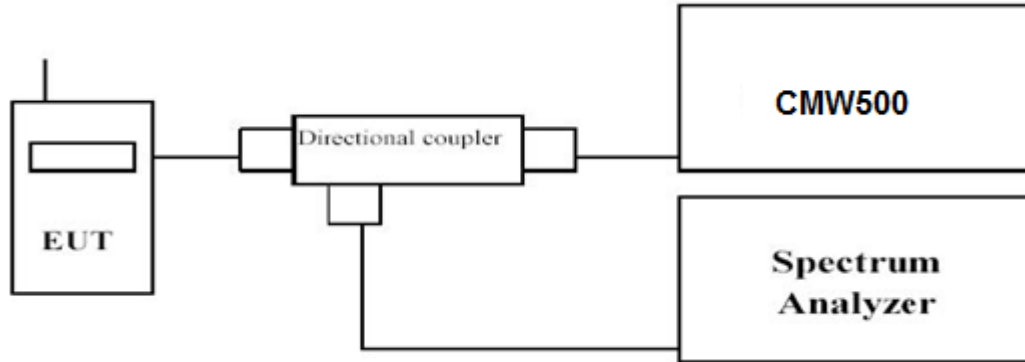

#### TEST PROCEDURE

1. The transmitter output port was connected to base station.
2. The RF output of EUT was connected to the power meter by RF cable and attenuator, the path loss was compensated to the results for each measurement.
3. Set EUT at maximum power through base station.
4. Select lowest and highest channels for each band and different modulation.
5. Measure Band edge using RMS (Average) detector by spectrum

#### TEST RESULTS

Temperature	24.5°C	Humidity	53.7%
Test Engineer	Jenny Zeng	Configurations	GSM

Remark:

We were tested all RB Configuration refer 3GPP TS151010 for each Channel Bandwidth of GSM850M,GSM1900M; recorded worst case for each Channel Bandwidth of GSM850, GSM1900M.

Test Mode	Channel	Frequency (MHz)	Band Edg Compliance (dBm)	Limits (dBm)	Verdict
GSM/TM1/GSM850	128	824.2	<-13dBm	-13dBm	PASS
	251	848.8	<-13dBm	-13dBm	
GSM/TM2/EDGE850	128	824.2	<-13dBm	-13dBm	PASS
	251	848.8	<-13dBm	-13dBm	
GSM/TM1/GSM1900	512	1850.2	<-13dBm	-13dBm	PASS
	810	1909.8	<-13dBm	-13dBm	
GSM/TM2/EDGE1900	512	1850.2	<-13dBm	-13dBm	PASS
	810	1909.8	<-13dBm	-13dBm	

Remark:

1. Test results including cable loss;
2. Please refer to following plots;

Band-edge Compliance

GSM/TM1/GSM850



Date: 21.MAR.2022 16:02:13

GSM/TM2/EDGE850



Date: 21.MAR.2022 16:38:11

Channel 128 / 824.2 MHz

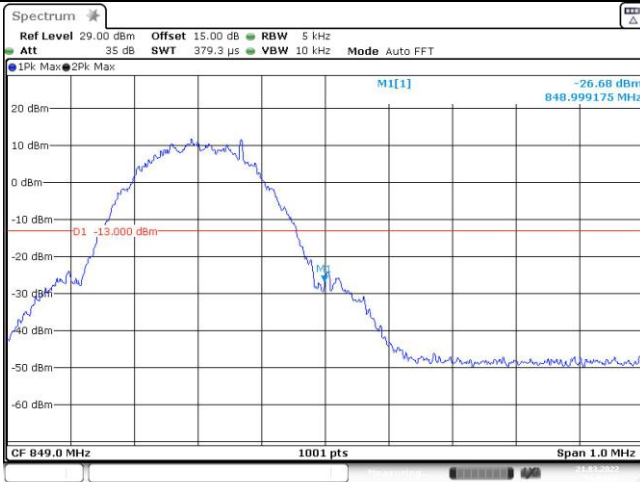

Date: 21.MAR.2022 16:03:58

Channel 128 / 824.2 MHz



Date: 21.MAR.2022 16:37:09

Channel 251 / 848.8 MHz

Channel 251 / 848.8 MHz

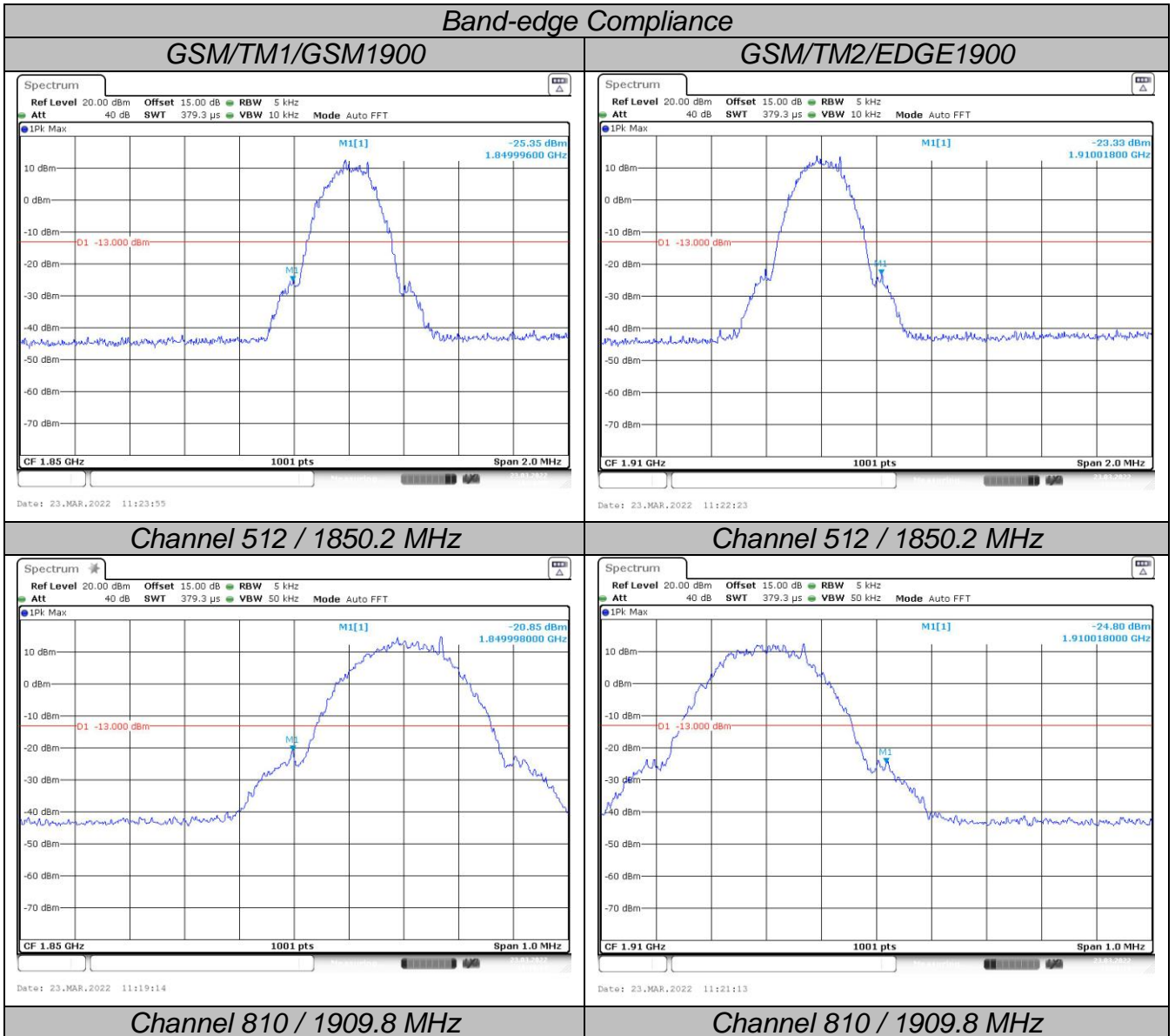

NOTE:We measured all modes and only recorded the worst case.

## 4.5 Spurious Emission

### LIMIT

FCC § 2.1053, §22.917, § 24.238.

### TEST CONFIGURATION

Conducted Spurious Measurement:

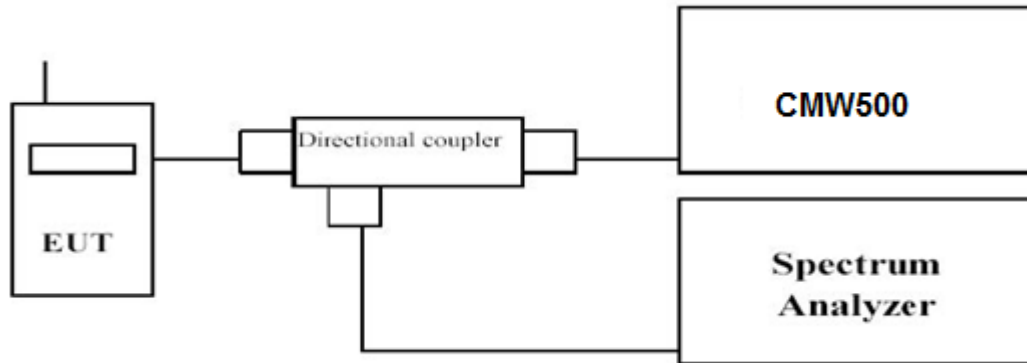

Radiated Spurious Measurement:

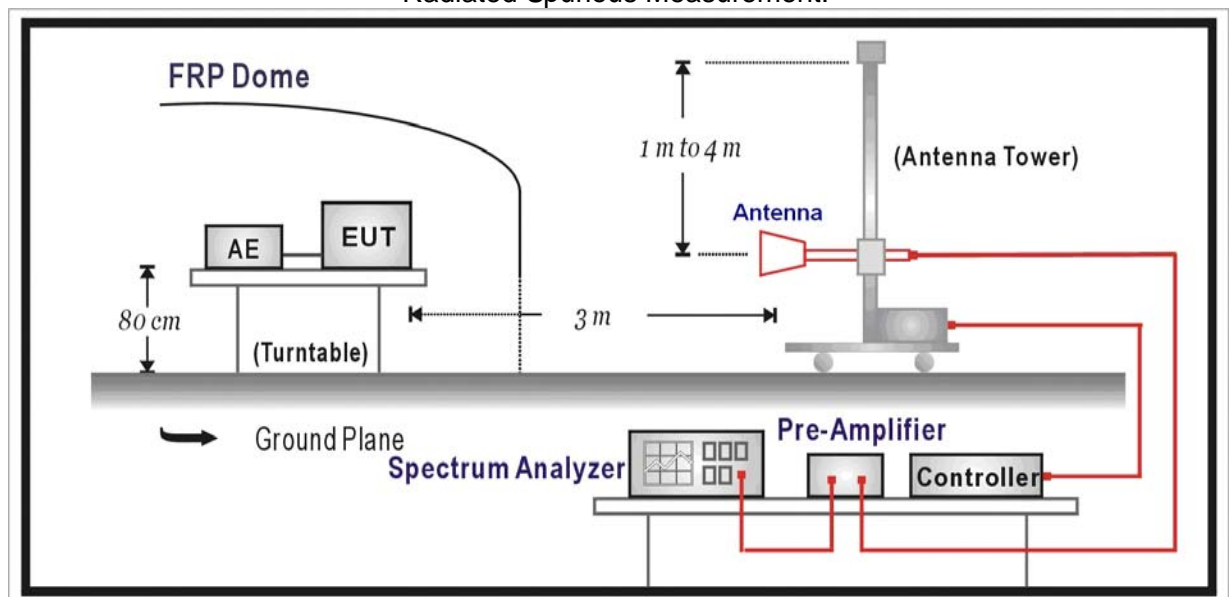

### TEST PROCEDURE

The EUT was setup according to EIA/TIA 603-E

#### **Conducted Spurious Measurement:**

- Place the EUT on a bench and set it in transmitting mode.
- Connect a low loss RF cable from the antenna port to a spectrum analyzer and CMW500 by a Directional Coupler.
- EUT Communicate with CMW500, then select a channel for testing.
- Add a correction factor to the display of spectrum, and then test.
- The resolution bandwidth of the spectrum analyzer was set sufficient scans were taken to show the out of band Emission if any up to 10<sup>th</sup> harmonic.
- Please refer to following tables for test antenna conducted emissions.

**Radiated Spurious Measurement:**

- a. The EUT shall be placed at the specified height on a support, and in the position closest to normal use as declared by provider.
- b. The test antenna shall be oriented initially for vertical polarization and shall be chosen to correspond to the frequency of the transmitter
- c. The output of the test antenna shall be connected to the measuring receiver.
- d. The transmitter shall be switched on and the measuring receiver shall be tuned to the frequency of the transmitter under test.
- e. The test antenna shall be raised and lowered through the specified range of height until a maximum signal level is detected by the measuring receiver.
- f. The transmitter shall then be rotated through 360° in the horizontal plane, until the maximum signal level is detected by the measuring receiver.
- g. The test antenna shall be raised and lowered again through the specified range of height until a maximum signal level is detected by the measuring receiver.
- h. The maximum signal level detected by the measuring receiver shall be noted.
- i. The transmitter shall be replaced by a substitution antenna.
- j. The substitution antenna shall be orientated for vertical polarization and the length of the substitution antenna shall be adjusted to correspond to the frequency of the transmitter.
- k. The substitution antenna shall be connected to a calibrated signal generator.
- l. If necessary, the input attenuator setting of the measuring receiver shall be adjusted in order to increase the sensitivity of the measuring receiver.
- m. The test antenna shall be raised and lowered through the specified range of height to ensure that the maximum signal is received.
- n. The input signal to the substitution antenna shall be adjusted to the level that produces a level detected by the measuring receiver, that is equal to the level noted while the transmitter radiated power was measured, corrected for the change of input attenuator setting of the measuring receiver.
- o. The measurement shall be repeated with the test antenna and the substitution antenna orientated for horizontal polarization.
- p. The measure of the effective radiated power is the larger of the two levels recorded at the input to the substitution antenna, corrected for gain of the substitution antenna if necessary.
- q. The resolution bandwidth of the spectrum analyzer was set at 100 kHz for Part 22 and 1MHz for Part 24. The frequency range was checked up to 10th harmonic.
- r. Test site anechoic chamber refer to ANSI C63.4:2014.

**TEST RESULTS**

Temperature	24.5°C	Humidity	53.7%
Test Engineer	Jenny Zeng	Configurations	GSM

**Conducted Measurement:**

Remark:

We were tested all RB Configuration refer 3GPP TS151010 for each Channel Bandwidth of GSM850M,GSM1900M; recorded worst case for each Channel Bandwidth of GSM850, GSM1900M.

Test Mode	Channel	Frequency (MHz)	Spurious RF Conducted Emission (dBm)	Limits (dBm)	Verdict
GSM/TM1/GSM850	128	824.2	<-13dBm	-13dBm	PASS
	190	836.6	<-13dBm	-13dBm	
	251	848.8	<-13dBm	-13dBm	
GSM/TM2/EDGE850	128	824.2	<-13dBm	-13dBm	PASS
	190	836.6	<-13dBm	-13dBm	
	251	848.8	<-13dBm	-13dBm	
GSM/TM1/GSM1900	512	1850.2	<-13dBm	-13dBm	PASS
	661	1880.0	<-13dBm	-13dBm	
	810	1909.8	<-13dBm	-13dBm	
GSM/TM2/EDGE1900	512	1850.2	<-13dBm	-13dBm	PASS
	661	1880.0	<-13dBm	-13dBm	
	810	1909.8	<-13dBm	-13dBm	

Remark:

- 1. Test results including cable loss;
- 2. Please refer to following plots;
- 3. We measured all modes and only recorded the worst case.



Spurious Emission on Antenna Port

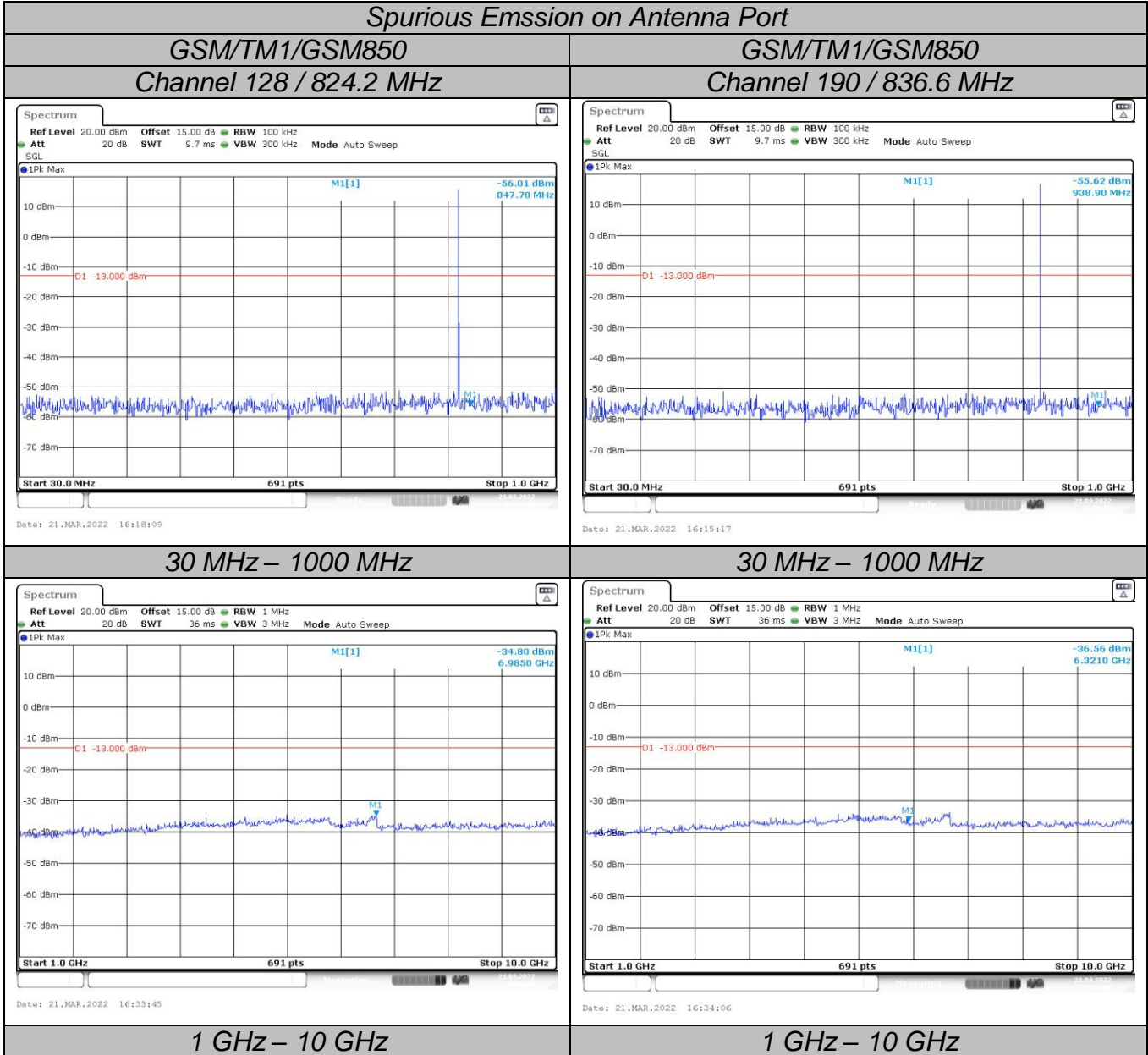

Spurious Emission on Antenna Port

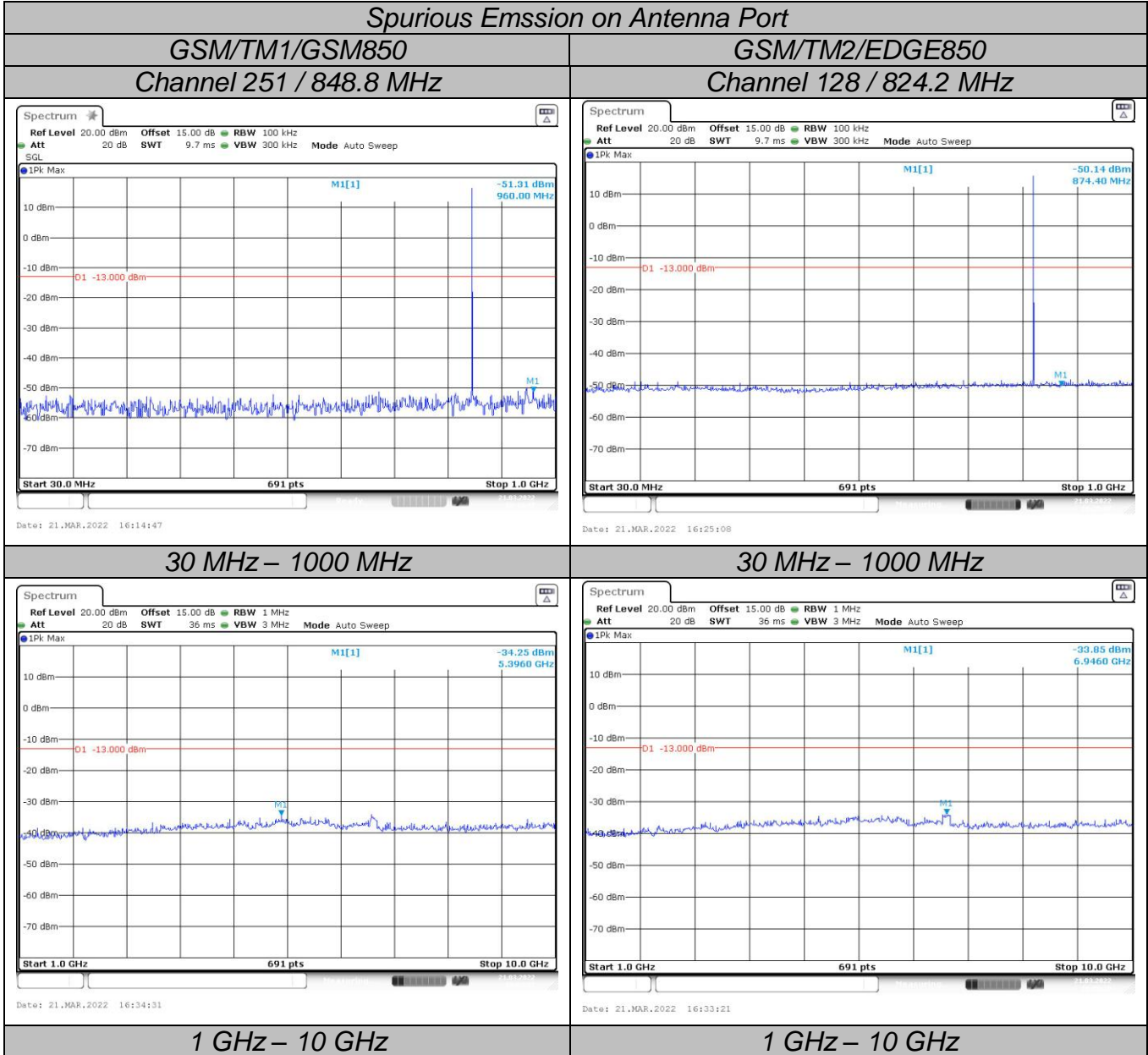

Spurious Emission on Antenna Port

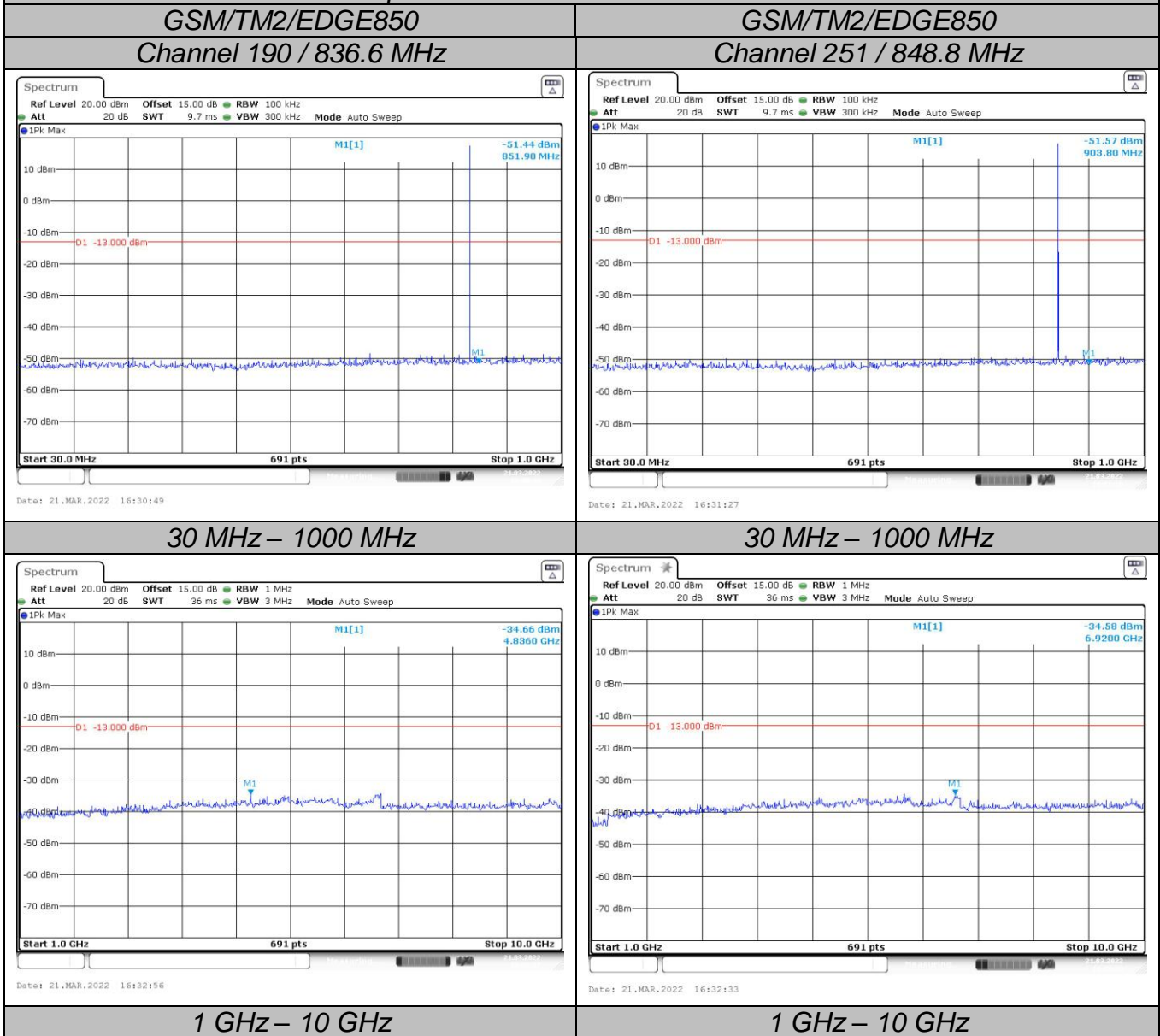

Spurious Emission on Antenna Port

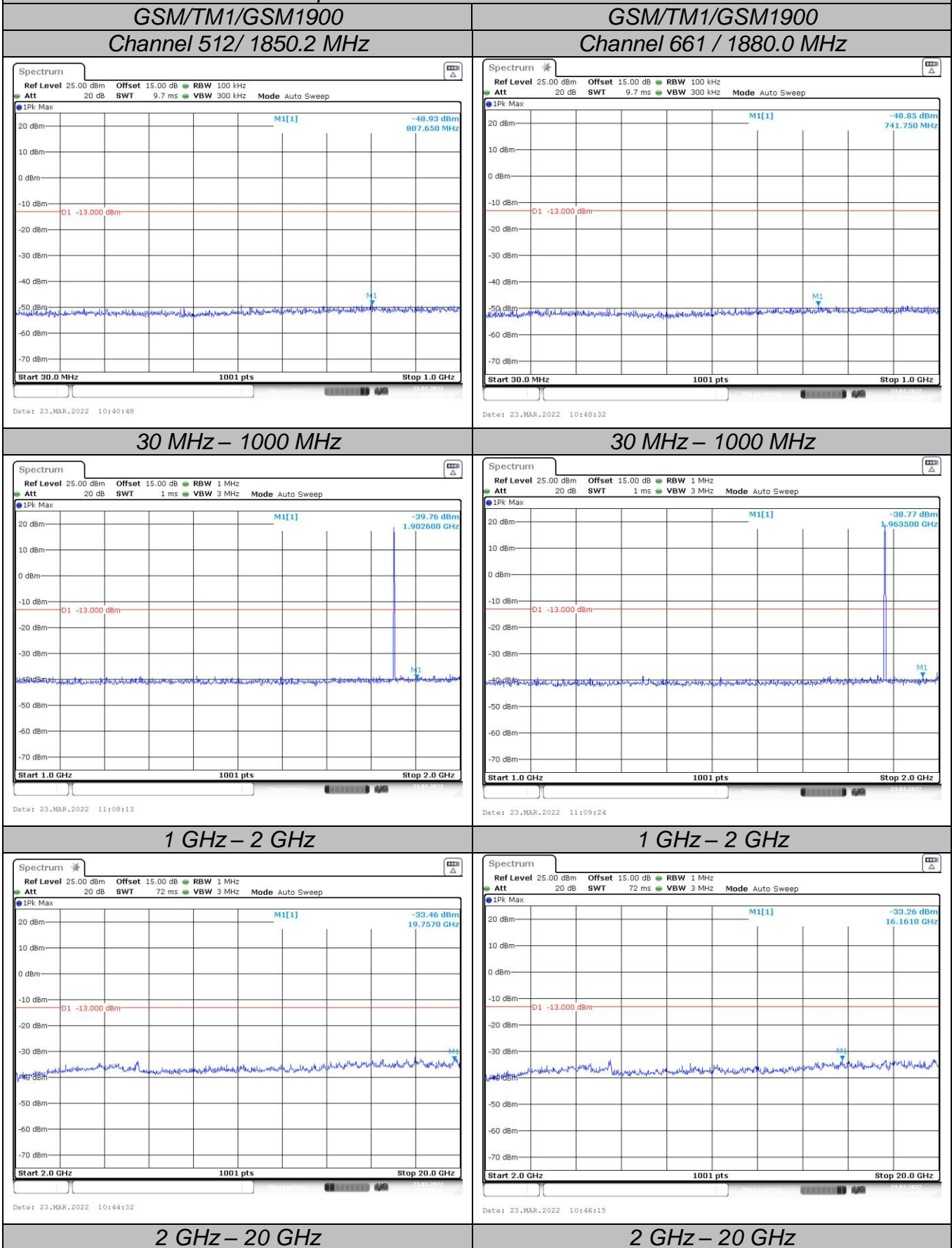

Spurious Emission on Antenna Port

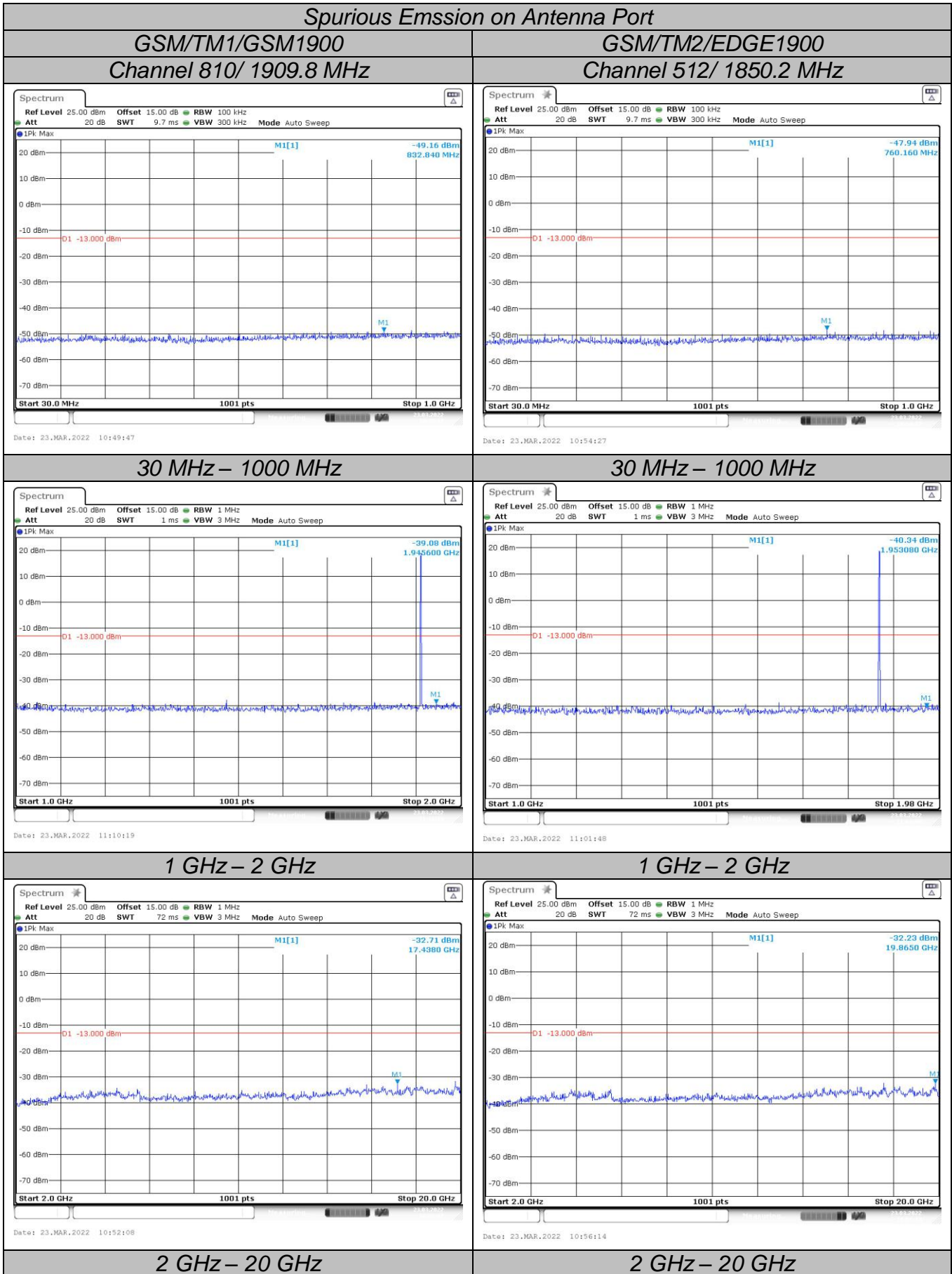

Spurious Emission on Antenna Port

GSM/TM1/GSM1900

GSM/TM2/EDGE1900

Channel 661 / 1880.0 MHz

Channel 810/ 1909.8 MHz

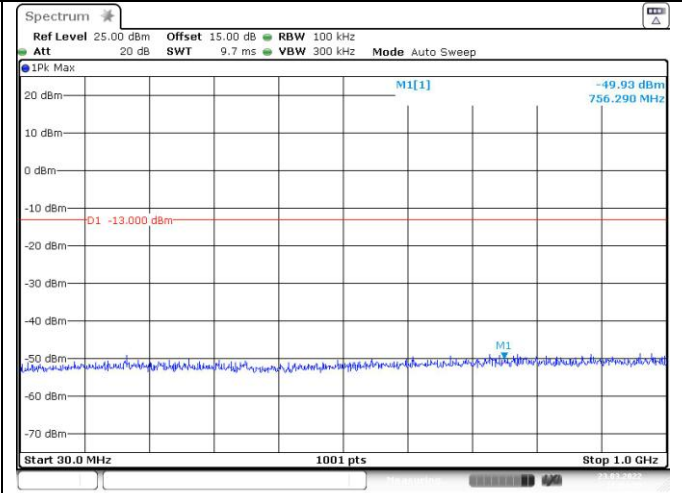
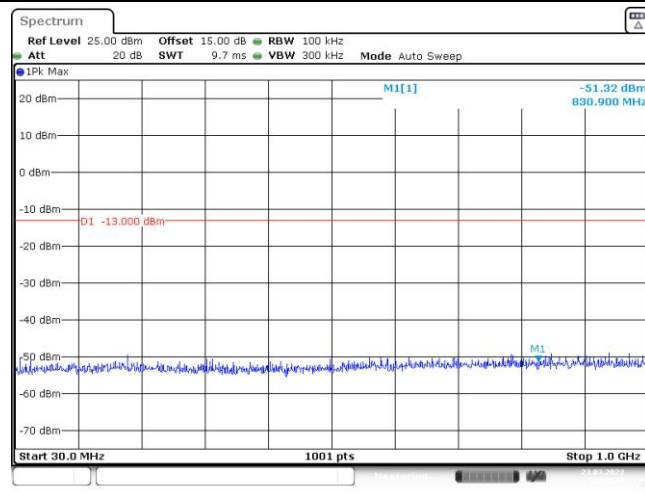

Date: 23.MAR.2022 10:58:46

Date: 23.MAR.2022 11:04:05

30 MHz – 1000 MHz

30 MHz – 1000 MHz

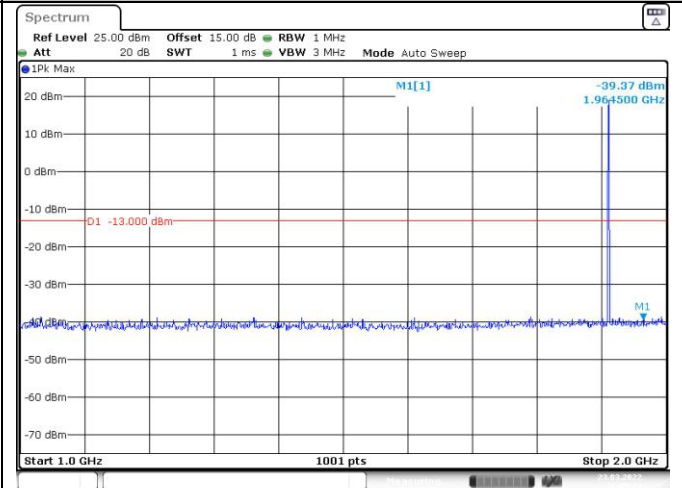
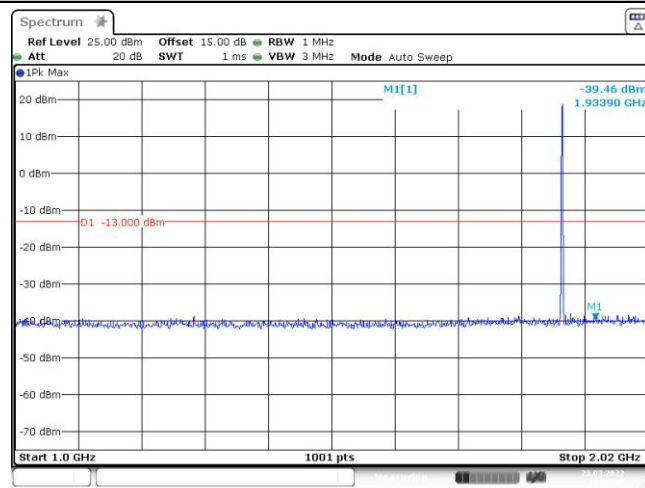

Date: 23.MAR.2022 10:59:56

Date: 23.MAR.2022 11:05:10

1 GHz – 2 GHz

1 GHz – 2 GHz

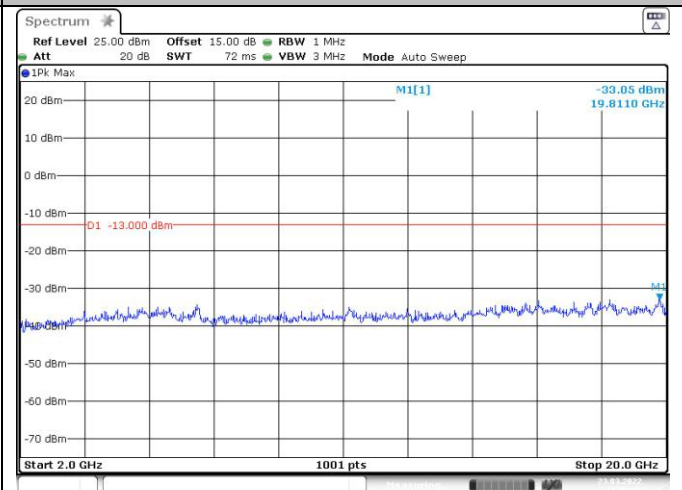
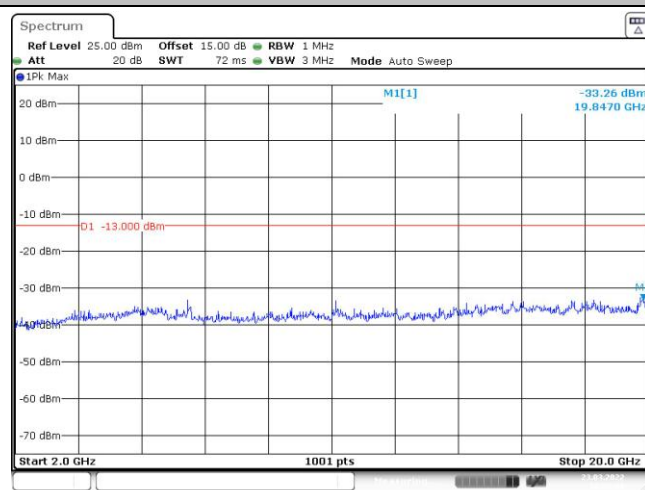

Date: 23.MAR.2022 10:57:06

Date: 23.MAR.2022 11:02:40

2 GHz – 20 GHz

2 GHz – 20 GHz

**Radiated Measurement:**

Remark:

We were tested all RB Configuration refer 3GPP TS151010 for each Channel Bandwidth of GSM850M,GSM1900M; recorded worst case for each Channel Bandwidth of GSM850M,GSM1900M.

Temperature	24.5℃	Humidity	53.7%
Test Engineer	Jenny Zeng	Configurations	GSM

**For Less than 1 GHz:***GSM/TM1/GSM850\_ Low Channel*

Frequency (MHz)	P <sub>Mea</sub> (dBm)	P <sub>cl</sub> (dB)	Diatance	G <sub>a</sub> Antenna Gain(dB)	Peak EIRP (dBm)	Limit (dBm)	Margin (dB)	Polarization
152.32	-45.78	3.87	3.00	8.75	-40.90	-13.00	-27.90	H
236.64	-45.98	4.09	3.00	6.84	-43.23	-13.00	-30.23	H
555.41	-41.75	4.01	3.00	8.40	-37.36	-13.00	-24.36	V
898.91	-43.54	4.12	3.00	6.91	-40.75	-13.00	-27.75	V

*GSM/TM1/GSM850\_ Middle Channel*

Frequency (MHz)	P <sub>Mea</sub> (dBm)	P <sub>cl</sub> (dB)	Diatance	G <sub>a</sub> Antenna Gain(dB)	Peak EIRP (dBm)	Limit (dBm)	Margin (dB)	Polarization
149.69	-45.93	3.94	3.00	8.64	-41.23	-13.00	-28.23	H
242.77	-46.60	4.24	3.00	6.88	-43.97	-13.00	-30.97	H
552.30	-42.75	3.67	3.00	8.61	-37.81	-13.00	-24.81	V
897.93	-44.57	4.39	3.00	6.81	-42.15	-13.00	-29.15	V

*GSM/TM1/GSM850\_ High Channel*

Frequency (MHz)	P <sub>Mea</sub> (dBm)	P <sub>cl</sub> (dB)	Diatance	G <sub>a</sub> Antenna Gain(dB)	Peak EIRP (dBm)	Limit (dBm)	Margin (dB)	Polarization
153.06	-47.72	4.05	3.00	8.60	-43.18	-13.00	-30.18	H
236.06	-45.72	4.33	3.00	6.90	-43.14	-13.00	-30.14	H
555.02	-44.32	3.88	3.00	8.36	-39.83	-13.00	-26.83	V
897.23	-45.02	4.28	3.00	6.95	-42.35	-13.00	-29.35	V

*GSM/TM2/ EDGE850\_ Low Channel*

Frequency (MHz)	P <sub>Mea</sub> (dBm)	P <sub>cl</sub> (dB)	Diatance	G <sub>a</sub> Antenna Gain(dB)	Peak EIRP (dBm)	Limit (dBm)	Margin (dB)	Polarization
157.17	-45.91	4.06	3.00	8.68	-41.28	-13.00	-28.28	H
234.65	-46.05	4.19	3.00	7.10	-43.13	-13.00	-30.13	H
556.59	-41.93	3.92	3.00	8.37	-37.48	-13.00	-24.48	V
898.08	-43.72	4.12	3.00	7.11	-40.74	-13.00	-27.74	V

*GSM/TM2/ EDGE850\_ Middle Channel*

Frequency (MHz)	P <sub>Mea</sub> (dBm)	P <sub>cl</sub> (dB)	Diatance	G <sub>a</sub> Antenna Gain(dB)	Peak EIRP (dBm)	Limit (dBm)	Margin (dB)	Polarization
153.80	-46.04	3.73	3.00	8.69	-41.08	-13.00	-28.08	H
242.08	-46.70	4.33	3.00	7.08	-43.95	-13.00	-30.95	H
552.40	-42.63	4.05	3.00	8.65	-38.04	-13.00	-25.04	V
904.59	-44.50	4.47	3.00	6.84	-42.14	-13.00	-29.14	V

*GSM/TM2/ EDGE850\_ High Channel*

Frequency (MHz)	P <sub>Mea</sub> (dBm)	P <sub>cl</sub> (dB)	Diatance	G <sub>a</sub> Antenna Gain(dB)	Peak EIRP (dBm)	Limit (dBm)	Margin (dB)	Polarization
154.07	-47.37	3.75	3.00	8.37	-42.75	-13.00	-29.75	H
235.81	-45.73	4.10	3.00	7.11	-42.72	-13.00	-29.72	H
561.24	-44.32	3.86	3.00	8.42	-39.76	-13.00	-26.76	V
900.74	-45.16	4.16	3.00	6.79	-42.53	-13.00	-29.53	V

*GSM/TM1/GSM1900\_ Low Channel*

Frequency (MHz)	P <sub>Mea</sub> (dBm)	P <sub>cl</sub> (dB)	Diatance	G <sub>a</sub> Antenna Gain(dB)	Peak EIRP (dBm)	Limit (dBm)	Margin (dB)	Polarization
151.88	-45.93	3.82	3.00	8.57	-41.19	-13.00	-28.19	H
236.98	-46.11	4.38	3.00	6.79	-43.70	-13.00	-30.70	H
554.93	-42.05	3.97	3.00	8.49	-37.53	-13.00	-24.53	V
897.90	-43.48	4.46	3.00	6.93	-41.00	-13.00	-28.00	V

*GSM/TM1/GSM1900\_ Middle Channel*

Frequency (MHz)	P <sub>Mea</sub> (dBm)	P <sub>cl</sub> (dB)	Diatance	G <sub>a</sub> Antenna Gain(dB)	Peak EIRP (dBm)	Limit (dBm)	Margin (dB)	Polarization
156.16	-45.98	3.70	3.00	8.65	-41.03	-13.00	-28.03	H
235.28	-46.66	4.33	3.00	6.95	-44.03	-13.00	-31.03	H
552.11	-42.58	3.79	3.00	8.60	-37.77	-13.00	-24.77	V
905.94	-44.59	4.47	3.00	6.84	-42.22	-13.00	-29.22	V

*GSM/TM1/GSM1900\_ High Channel*

Frequency (MHz)	P <sub>Mea</sub> (dBm)	P <sub>cl</sub> (dB)	Diatance	G <sub>a</sub> Antenna Gain(dB)	Peak EIRP (dBm)	Limit (dBm)	Margin (dB)	Polarization
152.14	-47.74	4.01	3.00	8.48	-43.27	-13.00	-30.27	H
240.54	-45.75	4.43	3.00	7.03	-43.16	-13.00	-30.16	H
556.43	-44.58	3.74	3.00	8.63	-39.68	-13.00	-26.68	V
902.63	-45.10	4.41	3.00	6.92	-42.59	-13.00	-29.59	V

*GSM/TM2/ EDGE1900\_ Low Channel*

Frequency (MHz)	P <sub>Mea</sub> (dBm)	P <sub>cl</sub> (dB)	Diatance	G <sub>a</sub> Antenna Gain(dB)	Peak EIRP (dBm)	Limit (dBm)	Margin (dB)	Polarization
149.68	-45.69	3.90	3.00	8.55	-41.05	-13.00	-28.05	H
234.65	-46.01	4.26	3.00	7.05	-43.22	-13.00	-30.22	H
561.01	-41.89	3.96	3.00	8.37	-37.48	-13.00	-24.48	V
906.05	-43.43	4.26	3.00	6.94	-40.75	-13.00	-27.75	V

*GSM/TM2/ EDGE1900\_ Middle Channel*

Frequency (MHz)	P <sub>Mea</sub> (dBm)	P <sub>cl</sub> (dB)	Diatance	G <sub>a</sub> Antenna Gain(dB)	Peak EIRP (dBm)	Limit (dBm)	Margin (dB)	Polarization
157.11	-46.13	3.85	3.00	8.63	-41.35	-13.00	-28.35	H
240.60	-46.47	4.32	3.00	6.86	-43.93	-13.00	-30.93	H
554.02	-42.62	3.75	3.00	8.41	-37.97	-13.00	-24.97	V
897.83	-44.73	4.16	3.00	7.13	-41.77	-13.00	-28.77	V

*GSM/TM2/ EDGE1900\_ High Channel*

Frequency (MHz)	P <sub>Mea</sub> (dBm)	P <sub>cl</sub> (dB)	Diatance	G <sub>a</sub> Antenna Gain(dB)	Peak EIRP (dBm)	Limit (dBm)	Margin (dB)	Polarization
157.81	-47.55	3.75	3.00	8.38	-42.93	-13.00	-29.93	H
235.62	-45.99	4.35	3.00	7.02	-43.32	-13.00	-30.32	H
560.32	-44.35	3.93	3.00	8.72	-39.56	-13.00	-26.56	V
901.08	-45.17	4.22	3.00	6.82	-42.58	-13.00	-29.58	V



**For More than 1 GHz:***GSM/TM1/GSM850\_ Low Channel*

Frequency (MHz)	P <sub>Mea</sub> (dBm)	P <sub>cl</sub> (dB)	Diatance	G <sub>a</sub> Antenna Gain(dB)	Peak EIRP (dBm)	Limit (dBm)	Margin (dB)	Polarization
1648.40	-45.69	3.86	3.00	8.56	-40.99	-13.00	-27.99	H
2472.60	-45.74	4.29	3.00	6.98	-43.05	-13.00	-30.05	H
1648.40	-41.69	3.86	3.00	8.56	-36.99	-13.00	-23.99	V
2472.60	-43.38	4.29	3.00	6.98	-40.69	-13.00	-27.69	V

*GSM/TM1/GSM850\_ Middle Channel*

Frequency (MHz)	P <sub>Mea</sub> (dBm)	P <sub>cl</sub> (dB)	Diatance	G <sub>a</sub> Antenna Gain(dB)	Peak EIRP (dBm)	Limit (dBm)	Margin (dB)	Polarization
1673.20	-45.88	3.90	3.00	8.58	-41.20	-13.00	-28.20	H
2509.80	-46.60	4.32	3.00	6.80	-44.12	-13.00	-31.12	H
1673.20	-42.83	3.90	3.00	8.58	-38.15	-13.00	-25.15	V
2509.80	-44.73	4.32	3.00	6.80	-42.25	-13.00	-29.25	V

*GSM/TM1/GSM850\_ High Channel*

Frequency (MHz)	P <sub>Mea</sub> (dBm)	P <sub>cl</sub> (dB)	Diatance	G <sub>a</sub> Antenna Gain(dB)	Peak EIRP (dBm)	Limit (dBm)	Margin (dB)	Polarization
1697.60	-47.42	3.91	3.00	9.06	-42.27	-13.00	-29.27	H
2546.40	-45.77	4.32	3.00	6.65	-43.44	-13.00	-30.44	H
1697.60	-44.28	3.91	3.00	9.06	-39.13	-13.00	-26.13	V
2546.40	-45.31	4.32	3.00	6.65	-42.98	-13.00	-29.98	V

*GSM/TM2/ EDGE850\_ Low Channel*

Frequency (MHz)	P <sub>Mea</sub> (dBm)	P <sub>cl</sub> (dB)	Diatance	G <sub>a</sub> Antenna Gain(dB)	Peak EIRP (dBm)	Limit (dBm)	Margin (dB)	Polarization
1648.40	-45.87	3.86	3.00	8.56	-41.17	-13.00	-28.17	H
2472.60	-45.99	4.29	3.00	6.98	-43.30	-13.00	-30.30	H
1648.40	-41.81	3.86	3.00	8.56	-37.11	-13.00	-24.11	V
2472.60	-43.34	4.29	3.00	6.98	-40.65	-13.00	-27.65	V

*GSM/TM2/ EDGE850\_ Middle Channel*

Frequency (MHz)	P <sub>Mea</sub> (dBm)	P <sub>cl</sub> (dB)	Diatance	G <sub>a</sub> Antenna Gain(dB)	Peak EIRP (dBm)	Limit (dBm)	Margin (dB)	Polarization
1673.20	-45.81	3.90	3.00	8.58	-41.13	-13.00	-28.13	H
2509.80	-46.79	4.32	3.00	6.80	-44.31	-13.00	-31.31	H
1673.20	-42.57	3.90	3.00	8.58	-37.89	-13.00	-24.89	V
2509.80	-44.75	4.32	3.00	6.80	-42.27	-13.00	-29.27	V

*GSM/TM2/ EDGE850\_ High Channel*

Frequency (MHz)	P <sub>Mea</sub> (dBm)	P <sub>cl</sub> (dB)	Diatance	G <sub>a</sub> Antenna Gain(dB)	Peak EIRP (dBm)	Limit (dBm)	Margin (dB)	Polarization
1697.60	-47.74	3.91	3.00	9.06	-42.59	-13.00	-29.59	H
2546.40	-45.75	4.32	3.00	6.65	-43.42	-13.00	-30.42	H
1697.60	-44.34	3.91	3.00	9.06	-39.19	-13.00	-26.19	V
2546.40	-45.10	4.32	3.00	6.65	-42.77	-13.00	-29.77	V

*GSM/TM1/GSM1900\_ Low Channel*

Frequency (MHz)	P <sub>Mea</sub> (dBm)	P <sub>cl</sub> (dB)	Diatance	G <sub>a</sub> Antenna Gain(dB)	Peak EIRP (dBm)	Limit (dBm)	Margin (dB)	Polarization
3700.40	-42.71	5.26	3.00	9.88	-38.09	-13.00	-25.09	H
5550.60	-48.25	6.11	3.00	11.36	-43.00	-13.00	-30.00	H
3700.40	-44.89	5.26	3.00	9.88	-40.27	-13.00	-27.27	V
5550.60	-50.09	6.11	3.00	11.36	-44.84	-13.00	-31.84	V

*GSM/TM1/GSM1900\_ Middle Channel*

Frequency (MHz)	P <sub>Mea</sub> (dBm)	P <sub>cl</sub> (dB)	Diatance	G <sub>a</sub> Antenna Gain(dB)	Peak EIRP (dBm)	Limit (dBm)	Margin (dB)	Polarization
3760.00	-44.21	5.32	3.00	10.03	-39.50	-13.00	-26.50	H
5640.00	-49.72	6.19	3.00	11.41	-44.50	-13.00	-31.50	H
3760.00	-45.02	5.32	3.00	10.03	-40.31	-13.00	-27.31	V
5640.00	-50.84	6.19	3.00	11.41	-45.62	-13.00	-32.62	V

*GSM/TM1/GSM1900\_ High Channel*

Frequency (MHz)	P <sub>Mea</sub> (dBm)	P <sub>cl</sub> (dB)	Diatance	G <sub>a</sub> Antenna Gain(dB)	Peak EIRP (dBm)	Limit (dBm)	Margin (dB)	Polarization
3819.60	-45.35	5.36	3.00	9.62	-41.09	-13.00	-28.09	H
5729.40	-50.87	6.24	3.00	11.46	-45.65	-13.00	-32.65	H
3819.60	-46.42	5.36	3.00	9.62	-42.16	-13.00	-29.16	V
5729.40	-51.34	6.24	3.00	11.46	-46.12	-13.00	-33.12	V

*GSM/TM2/ EDGE1900\_ Low Channel*

Frequency (MHz)	P <sub>Mea</sub> (dBm)	P <sub>cl</sub> (dB)	Diatance	G <sub>a</sub> Antenna Gain(dB)	Peak EIRP (dBm)	Limit (dBm)	Margin (dB)	Polarization
3700.40	-42.66	5.26	3.00	9.88	-38.04	-13.00	-25.04	H
5550.60	-48.40	6.11	3.00	11.36	-43.15	-13.00	-30.15	H
3700.40	-44.79	5.26	3.00	9.88	-40.17	-13.00	-27.17	V
5550.60	-49.93	6.11	3.00	11.36	-44.68	-13.00	-31.68	V

*GSM/TM2/ EDGE1900\_ Middle Channel*

Frequency (MHz)	P <sub>Mea</sub> (dBm)	P <sub>cl</sub> (dB)	Diatance	G <sub>a</sub> Antenna Gain(dB)	Peak EIRP (dBm)	Limit (dBm)	Margin (dB)	Polarization
3760.00	-44.26	5.32	3.00	10.03	-39.55	-13.00	-26.55	H
5640.00	-50.07	6.19	3.00	11.41	-44.85	-13.00	-31.85	H
3760.00	-45.24	5.32	3.00	10.03	-40.53	-13.00	-27.53	V
5640.00	-50.85	6.19	3.00	11.41	-45.63	-13.00	-32.63	V

*GSM/TM2/ EDGE1900\_ High Channel*

Frequency (MHz)	P <sub>Mea</sub> (dBm)	P <sub>cl</sub> (dB)	Diatance	G <sub>a</sub> Antenna Gain(dB)	Peak EIRP (dBm)	Limit (dBm)	Margin (dB)	Polarization
3819.60	-45.46	5.36	3.00	9.62	-41.20	-13.00	-28.20	H
5729.40	-50.92	6.24	3.00	11.46	-45.70	-13.00	-32.70	H
3819.60	-46.37	5.36	3.00	9.62	-42.11	-13.00	-29.11	V
5729.40	-51.34	6.24	3.00	11.46	-46.12	-13.00	-33.12	V

## Notes:

1. All channel bandwidth were tested, the report recorded the worst data.
2.  $EIRP = P_{Mea}(dBm) - P_{cl}(dB) + P_{Ag}(dB) + G_a(dBi)$
3.  $ERP = EIRP - 2.15dBi$  as EIRP by subtracting the gain of the dipole.
4.  $Margin = EIRP - Limit$
5. We measured all modes and only recorded the worst case.

## 4.6 Frequency Stability under Temperature & Voltage Variations

### LIMIT

FCC § 2.1055 (a), § 2.1055 (d), §22.355, §24.235 .

### TEST CONFIGURATION

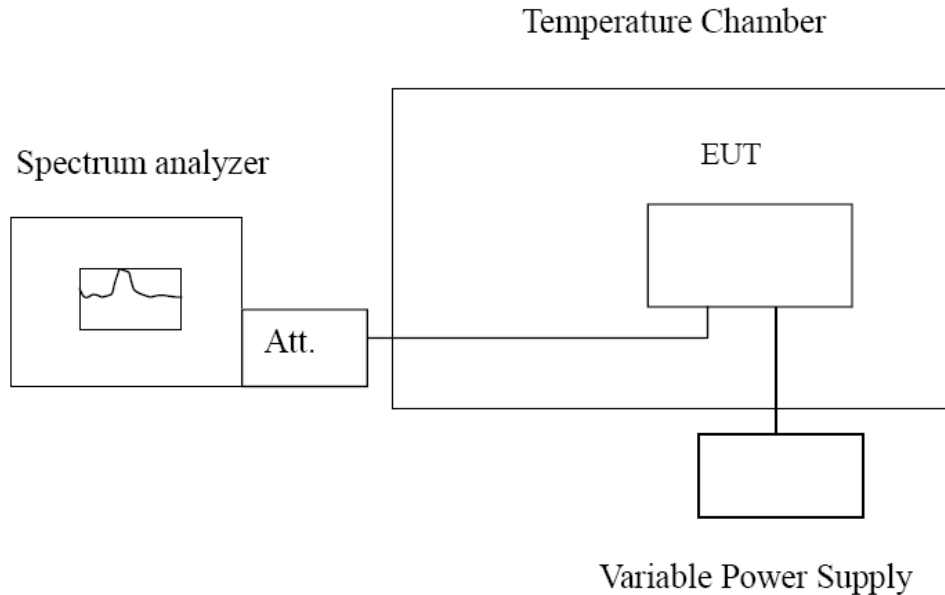

### TEST PROCEDURE

The EUT was setup according to EIA/TIA 603D

#### **Frequency Stability Under Temperature Variations:**

In order to measure the carrier frequency under the condition of AFC lock, it is necessary to make measurements with the EUT in a "call mode". This is accomplished with the use of R&S CMW500 DIGITAL RADIO COMMUNICATION TESTER.

1. Measure the carrier frequency at room temperature.
2. Subject the EUT to overnight soak at -30°C.
3. With the EUT, powered via nominal voltage, connected to the CMW500 and in a simulated call on middle channel for LTE band 5, measure the carrier frequency. These measurements should be made within 2 minutes of Powering up the EUT, to prevent significant self-warming.
4. Repeat the above measurements at 10°C increments from -30°C to +50°C. Allow at least 1.5 hours at each temperature, unpowered, before making measurements.
5. Re-measure carrier frequency at room temperature with nominal voltage. Vary supply voltage from minimum voltage to maximum voltage, in 0.1Volt increments re-measuring carrier frequency at each voltage. Pause at nominal voltage for 1.5 hours unpowered, to allow any self-heating to stabilize, before continuing.
6. Subject the EUT to overnight soak at +50°C.
7. With the EUT, powered via nominal voltage, connected to the CMW500 and in a simulated call on the centre channel, measure the carrier frequency. These measurements should be made within 2 minutes of Powering up the EUT, to prevent significant self-warming.
8. Repeat the above measurements at 10 °C increments from +50°C to -30°C. Allow at least 1.5 hours at each temperature, unpowered, before making measurements
9. At all temperature levels hold the temperature to +/- 0.5°C during the measurement procedure.

#### **Frequency Stability Under Voltage Variations:**

Set chamber temperature to 20°C. Use a variable AC power supply / DC power source to power the EUT and set the voltage to rated voltage. Set the spectrum analyzer RBW low enough to obtain the desired frequency resolution and recorded the frequency.

Reduce the input voltage to specify extreme voltage variation ( $\pm 15\%$ ) and endpoint, record the maximum frequency change.

**TEST RESULTS**

Remark:

We were tested all RB Configuration refer 3GPP TS151010 for each Channel Bandwidth of GSM850M,GSM1900M; recorded worst case for each Channel Bandwidth of GSM850M,GSM1900M.

Temperature	24.5°C	Humidity	53.7%
Test Engineer	Jenny Zeng	Configurations	GSM

GSM/TM1/GSM850					
DC Power	Temperature (°C)	Frequency error(Hz)	Frequency error(ppm)	Limit (ppm)	Verdict
DC 4.24V	25	-27	-0.033	±2.50	PASS
DC 3.47V	25	-6	-0.007	±2.50	PASS
DC 3.85V	25	49	0.059	±2.50	PASS
DC 3.85V	-30	1	0.001	±2.50	PASS
DC 3.85V	-20	-39	-0.047	±2.50	PASS
DC 3.85V	-10	15	0.018	±2.50	PASS
DC 3.85V	0	-42	-0.051	±2.50	PASS
DC 3.85V	10	-19	-0.023	±2.50	PASS
DC 3.85V	20	-37	-0.045	±2.50	PASS
DC 3.85V	30	-24	-0.029	±2.50	PASS
DC 3.85V	40	-36	-0.044	±2.50	PASS
DC 3.85V	50	-1	-0.001	±2.50	PASS

GSM/TM1/GSM1900					
DC Power	Temperature (°C)	Frequency error(Hz)	Frequency error(ppm)	Limit (ppm)	Verdict
DC 4.24V	25	-14	-0.007	±2.50	PASS
DC 3.47V	25	-10	-0.005	±2.50	PASS
DC 3.85V	25	6	0.003	±2.50	PASS
DC 3.85V	-30	17	0.009	±2.50	PASS
DC 3.85V	-20	-9	-0.005	±2.50	PASS
DC 3.85V	-10	-31	-0.016	±2.50	PASS
DC 3.85V	0	27	0.014	±2.50	PASS
DC 3.85V	10	10	0.005	±2.50	PASS
DC 3.85V	20	47	0.025	±2.50	PASS
DC 3.85V	30	-45	-0.024	±2.50	PASS
DC 3.85V	40	37	0.020	±2.50	PASS
DC 3.85V	50	-36	-0.019	±2.50	PASS

NOTE:We measured all modes and only recorded the worst case.

## 5 TEST SETUP PHOTOS OF THE EUT

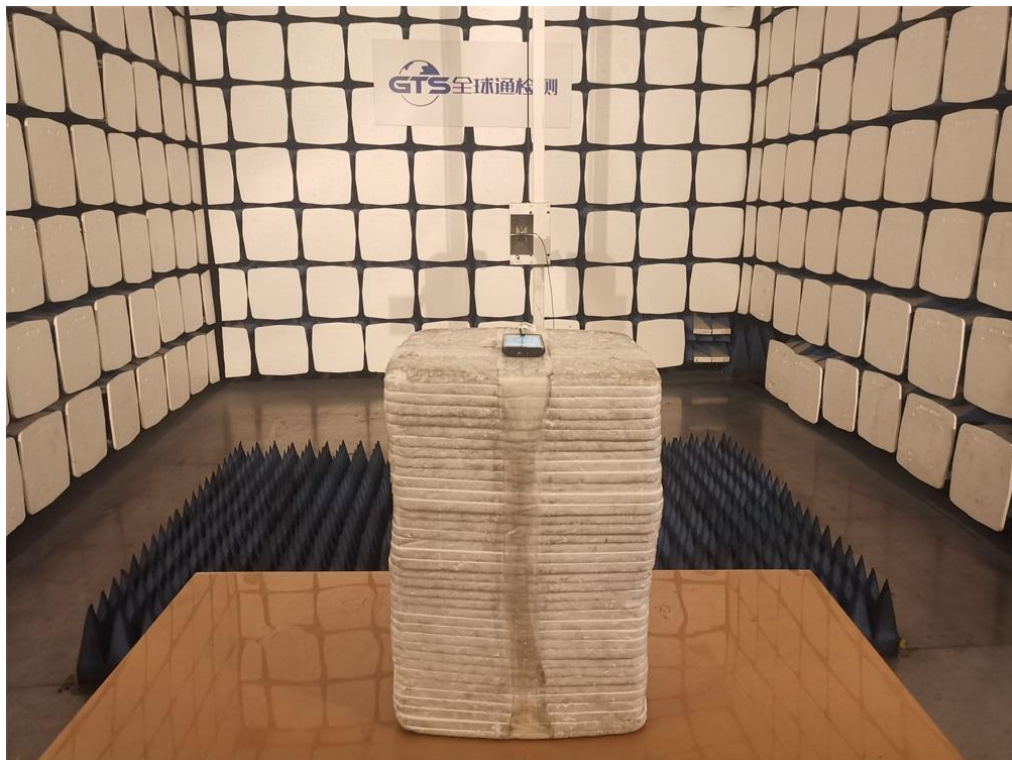
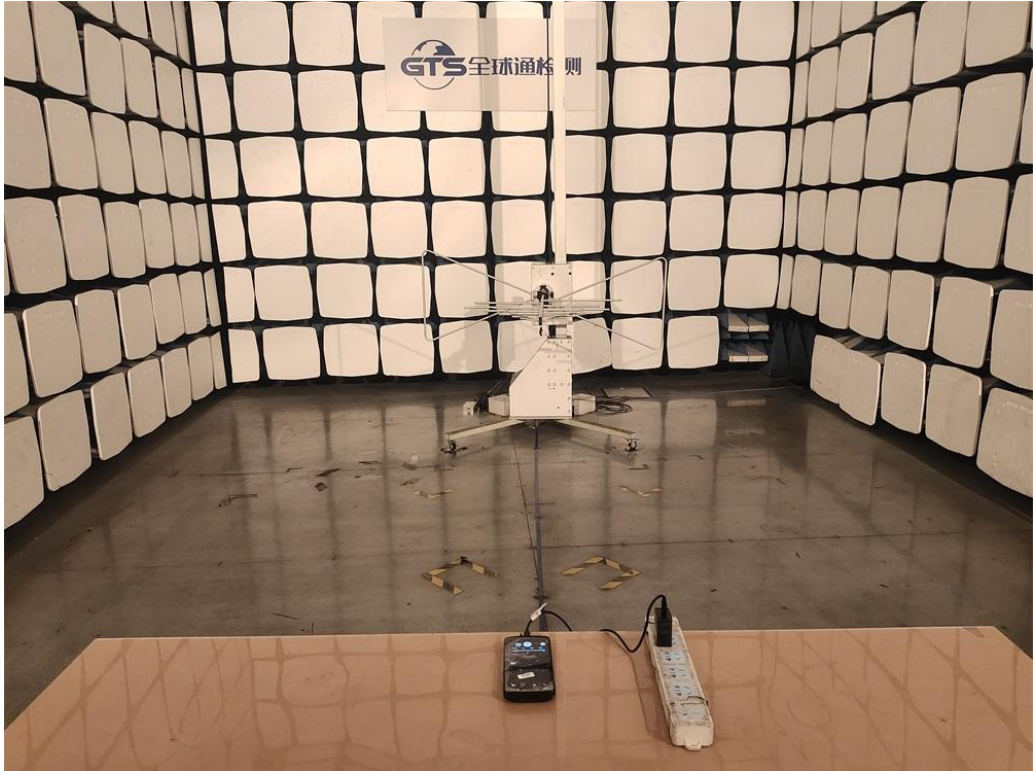

## **6 EXTERNAL AND INTERNAL PHOTOS OF THE EUT**

Reference to the Test Report: GTS20220307015-1-1.

.....**End of Report**.....