

# FCC Radio Test Report

## FCC ID: 2AC4M-MC-01

This report concerns (check one):  Original Grant  Class II Change

**Project No.** : 1409003  
**Equipment** : MobiTV Connect  
**Model Name** : MC-01; MC-XX (X=0-9, A-Z, Blank, or "-")  
**Applicant** : MobiTV, Inc.  
**Address** : 6425 Christie Avenue., 5th floor, Emeryville, CA  
94608, USA

**Date of Receipt** : Sep. 03, 2014  
**Date of Test** : Sep. 03, 2014 ~ Nov. 03, 2014  
**Issued Date** : Nov. 04, 2014  
**Tested by** : BTL Inc.

**Testing Engineer** : Rush Kao  
(Rush Kao)

**Technical Manager** : Jeff Yang  
(Jeff Yang)

**Authorized Signatory** : Andy Chiu  
(Andy Chiu)

# B T L I N C .

B1, No.37, Lane 365, Yang Guang St.,  
Nei-Hu District, Taipei City 114, Taiwan.  
TEL:+886-0-2657-3299 FAX: +886-2- 2657-3331

### **Declaration**

**BTL** represents to the client that testing is done in accordance with standard procedures as applicable and that test instruments used has been calibrated with the standards traceable to National Measurement Laboratory (**NML**) of **R.O.C**, or National Institute of Standards and Technology (**NIST**) of **U.S.A**.

**BTL's** reports apply only to the specific samples tested under conditions. It is manufacture's responsibility to ensure that additional production units of this model are manufactured with the identical electrical and mechanical components. **BTL** shall have no liability for any declarations, inferences or generalizations drawn by the client or others from **BTL** issued reports.

**BTL's** reports must not be used by the client to claim product endorsement by the authorities or any agency of the Government.

This report is the confidential property of the client. As a mutual protection to the clients, the public and **BTL-self**, extracts from the test report shall not be reproduced except in full with **BTL's** authorized written approval.

**BTL's** laboratory quality assurance procedures are in compliance with the **ISO Guide 17025** requirements, and accredited by the conformity assessment authorities listed in this test report.

### **Limitation**

For the use of the authority's logo is limited unless the Test Standard(s)/Scope(s)/Item(s) mentioned in this test report is (are) included in the conformity assessment authorities acceptance respective.

<b>Table of Contents</b>	<b>Page</b>
<b>1 . CERTIFICATION</b>	<b>6</b>
<b>2 . SUMMARY OF TEST RESULTS</b>	<b>7</b>
2.1 TEST FACILITY	8
2.2 MEASUREMENT UNCERTAINTY	8
<b>3 . GENERAL INFORMATION</b>	<b>9</b>
3.1 GENERAL DESCRIPTION OF EUT	9
3.4 BLOCK DIAGRAM SHOWING THE CONFIGURATION OF SYSTEM TESTED	11
3.5 DESCRIPTION OF SUPPORT UNITS	11
<b>4 . EMC EMISSION TEST</b>	<b>12</b>
4.1 CONDUCTED EMISSION MEASUREMENT	12
4.1.1 POWER LINE CONDUCTED EMISSION LIMITS	12
4.1.2 TEST PROCEDURE	12
4.1.3 DEVIATION FROM TEST STANDARD	12
4.1.4 TEST SETUP	13
4.1.5 EUT OPERATING CONDITIONS	13
4.1.6 EUT TEST CONDITIONS	13
4.1.7 TEST RESULTS	13
4.2 RADIATED EMISSION MEASUREMENT	14
4.2.1 RADIATED EMISSION LIMITS	14
4.2.2 TEST PROCEDURE	15
4.2.3 DEVIATION FROM TEST STANDARD	15
4.2.4 TEST SETUP	16
4.2.5 EUT OPERATING CONDITIONS	17
4.2.6 EUT TEST CONDITIONS	17
4.2.7 TEST RESULTS (9KHZ TO 30MHZ)	17
4.2.8 TEST RESULTS (BETWEEN 30MHZ TO 1000 MHZ)	18
4.2.9 TEST RESULTS (ABOVE 1000 MHZ)	18
<b>5 . BANDWIDTH TEST</b>	<b>19</b>
5.1 APPLIED PROCEDURES / LIMIT	19
5.1.1 TEST PROCEDURE	19
5.1.2 DEVIATION FROM STANDARD	19
5.1.3 TEST SETUP	19
5.1.4 EUT OPERATION CONDITIONS	19
5.1.5 EUT TEST CONDITIONS	19
5.1.6 TEST RESULTS	19
<b>6 . MAXIMUM OUTPUT POWER TEST</b>	<b>20</b>
6.1 APPLIED PROCEDURES / LIMIT	20

<b>Table of Contents</b>	<b>Page</b>
6.1.1 TEST PROCEDURE	20
6.1.2 DEVIATION FROM STANDARD	20
6.1.3 TEST SETUP	20
6.1.4 EUT OPERATION CONDITIONS	20
6.1.5 EUT TEST CONDITIONS	20
6.1.6 TEST RESULTS	20
<b>7 . ANTENNA CONDUCTED SPURIOUS EMISSION</b>	<b>21</b>
7.1 APPLIED PROCEDURES / LIMIT	21
7.1.1 TEST PROCEDURE	21
7.1.2 DEVIATION FROM STANDARD	21
7.1.3 TEST SETUP	21
7.1.4 EUT OPERATION CONDITIONS	21
7.1.5 EUT OPERATION CONDITIONS	21
7.1.6 TEST RESULTS	21
<b>8 . POWER SPECTRAL DENSITY TEST</b>	<b>22</b>
8.1 APPLIED PROCEDURES / LIMIT	22
8.1.1 TEST PROCEDURE	22
8.1.2 DEVIATION FROM STANDARD	22
8.1.3 TEST SETUP	22
8.1.4 EUT OPERATION CONDITIONS	22
8.1.5 EUT TEST CONDITIONS	22
8.1.6 TEST RESULTS	22
<b>9 . MEASUREMENT INSTRUMENTS LIST</b>	<b>23</b>
<b>10 . EUT TEST PHOTO</b>	<b>25</b>
<b>ATTACHMENT A - CONDUCTED EMISSION</b>	<b>29</b>
<b>ATTACHMENT B - RADIATED EMISSION (9KHZ-30MHZ)</b>	<b>32</b>
<b>ATTACHMENT C - RADIATED EMISSION BETWEEN 30MHZ AND 1000MHZ)</b>	<b>34</b>
<b>ATTACHMENT D - RADIATED EMISSION (ABOVE 1000MHZ)</b>	<b>37</b>
<b>ATTACHMENT E - BANDWIDTH</b>	<b>50</b>
<b>ATTACHMENT F - MAXIMUM OUTPUT POWER TEST</b>	<b>53</b>
<b>ATTACHMENT G - ANTENNA CONDUCTED SPURIOUS EMISSION</b>	<b>54</b>
<b>ATTACHMENT H - POWER SPECTRAL DENSITY TEST</b>	<b>58</b>

## REPORT ISSUED HISTORY

Issued No.	Description	Issued Date
BTL-FCCP-3-1409003	Original Issue.	Nov. 04, 2014

## 1. CERTIFICATION

Equipment : MobiTV Connect  
Brand Name : MobiTV  
Model Name : MC-01; MC-XX (X=0-9, A-Z, Blank, or "-")  
Applicant : MobiTV, Inc.  
Manufacturer: JABIL CIRCUIT  
Address : 10560 Dr. Martin Luther King Jr. St. N.St. Petersburg, FL 33716 USA  
Factory : JABIL CIRCUIT INDIA PVT LTD  
Address : B-26 MIDC RD, EHTP UNIT, RANJANGAON MIDC IND AREA, TALUKA SHIRUR, DIST PUNE MH, INDIA  
Date of Test : Sep. 03, 2014 ~ Nov. 03, 2014  
Test Sample : ENGINEERING SAMPLE  
Standard(s) : FCC Part15, Subpart C :2013 (15.247) / ANSI C63.4-2009 /  
FCC KDB Publication No. 558074 D01 DTS Meas Guidance v03r02

The above equipment has been tested and found compliance with the requirement of the relative standards by BTL Inc.

The test data, data evaluation, and equipment configuration contained in our test report (Ref No. BTL-FCCP-3-1409003) were obtained utilizing the test procedures, test instruments, test sites that has been accredited by the Authority of TAF according to the ISO-17025 quality assessment standard and technical standard(s).

## 2. SUMMARY OF TEST RESULTS

Test procedures according to the technical standard(s):

<b>Applied Standard(s): FCC Part15 (15.247) , Subpart C</b>				
Standard(s)	Section	Test Item	Judgment	Remark
	15.207	Conducted Emission	PASS	
	15.247(d)	Antenna conducted Spurious Emission	PASS	
	15.247(a)(2)	6dB Bandwidth	PASS	
	15.247(b)(3)	Peak Output Power	PASS	
	15.247(e)	Power Spectral Density	PASS	
	15.203	Antenna Requirement	PASS	
	15.209/15.205	Transmitter Radiated Emissions	PASS	

**NOTE:**

(1) "N/A" denotes test is not applicable to this device.

(2) The test follows FCC KDB Publication No. 558074 D01 DTS Meas Guidance v03r02 (Measurement Guidelines of DTS)

## 2.1 TEST FACILITY

### Conducted emission Test:

**C02:** (VCCI RN: C-3477; FCC RN: 614388; FCC DN: TW1054)  
1F., No. 61, Ln. 77, Sing-ai Rd., Neihu Dist., Taipei City 114, Taiwan (R.O.C.)

### Radiated emission Test (Below 1 GHz):

**CB08:** (FCC RN: 614388; FCC DN: TW1054; IC Assigned Code: 4428C-1)  
1F., No. 61, Ln. 77, Sing-ai Rd., Neihu Dist., Taipei City 114, Taiwan (R.O.C.)

### Radiated emission Test (Above 1 GHz):

**CB08:** (VCCI RN: G-91; FCC RN: 614388; FCC DN: TW1054; IC Assigned Code: 4428C-1)  
1F., No. 61, Ln. 77, Sing-ai Rd., Neihu Dist., Taipei City 114, Taiwan (R.O.C.)

## 2.2 MEASUREMENT UNCERTAINTY

**The measurement uncertainty is not specified by FCC rules for reference only.**

The reported uncertainty of measurement  $y \pm U$ , where expanded uncertainty  $U$  is based on a standard uncertainty multiplied by a coverage factor of  $k=2$ , providing a level of confidence of approximately **95%**.

The measurement instrumentation uncertainty considerations contained in CISPR 16-4-2.

### A. Conducted emission test:

Test Site	Measurement Frequency Range	U, (dB)	NOTE
C02	150 kHz ~ 30 MHz	1.94	

### B. Radiated emission test:

Test Site	Item	Measurement Frequency Range	Uncertainty	NOTE	
CB08	Radiated emission at 3m	Horizontal Polarization	30 - 200MHz	3.35 dB	
			200 - 1000MHz	3.11 dB	
			1 - 18GHz	3.97 dB	
			18 - 40GHz	4.01 dB	
		Vertical Polarization	30 - 200MHz	3.22 dB	
			200 - 1000MHz	3.24 dB	
			1 - 18GHz	4.05 dB	
			18 - 40GHz	4.04 dB	

Our calculated Measurement Instrumentation Uncertainty is shown in the tables above. These are our  $U_{lab}$  values in CISPR 16-4-2 terminology.

Since Table 1 of CISPR 16-4-2 has values of measurement instrumentation uncertainty, called  $U_{CISPR}$ , as follows:

Conducted Disturbance (mains port) – 150 kHz – 30 MHz : 3.6 dB

Radiated Disturbance (electric field strength on an open area test site or alternative test site) – 30 MHz – 1000 MHz : 5.2 dB

It can be seen that our  $U_{lab}$  values are smaller than  $U_{CISPR}$ .



### 3. GENERAL INFORMATION

#### 3.1 GENERAL DESCRIPTION OF EUT

Equipment	MobiTV Connect	
Brand Name	MobiTV	
Model Name	MC-01; MC-XX (X=0-9, A-Z, Blank, or "-")	
Model Difference	Only for Different Brands or Markets	
Product Description	Operation Frequency	2402~2480 MHz
	Modulation Technology	GFSK(1Mbps)
	Bit Rate of Transmitter	
	Output Power (Max.)	2.68 dBm (0.0019W)(1Mbps)
Power Source	DC Voltage supplied from AC/DC adapter. #1 Brand/Model: AMIGO/AMS57-0501200FU #2 Brand/Model: JQH/NSA8UU-050150 #3 Brand/Model: Liteon/PA-1060-07	
Power Rating	I/P:100-240V 50/60Hz O/P:0.2A 5V 1.2A	

Note:

1. For a more detailed features description, please refer to the manufacturer's specifications or the User's Manual.

2.

Channel List			
Channel	Frequency (MHz)	Channel	Frequency (MHz)
00	2402	20	2442
01	2404	21	2444
02	2406	22	2446
03	2408	23	2448
04	2410	24	2450
05	2412	25	2452
06	2414	26	2454
07	2416	27	2456
08	2418	28	2458
09	2420	29	2460
10	2422	30	2462
11	2424	31	2464
12	2426	32	2466
13	2428	33	2468
14	2430	34	2470
15	2432	35	2472
16	2434	36	2474
17	2436	37	2476
18	2438	38	2478
19	2440	39	2480

3. Table for Filed Antenna  
The equipment has two groups antenna.

Group 1

Ant	Brand	Model Name	Antenna Type	Connector	Gain (dBi)	Note
1	Ethertronics	5001787	PIFA	N/A	4.5	-

Group 2

Ant	Brand	Model Name	Antenna Type	Connector	Gain (dBi)	Note
1	Tongda	N/A	PIFA	N/A	2.3	-

The group1 is the worst and recorded in this report

### 3.4 BLOCK DIAGRAM SHOWING THE CONFIGURATION OF SYSTEM TESTED

Radiated TX Mode:

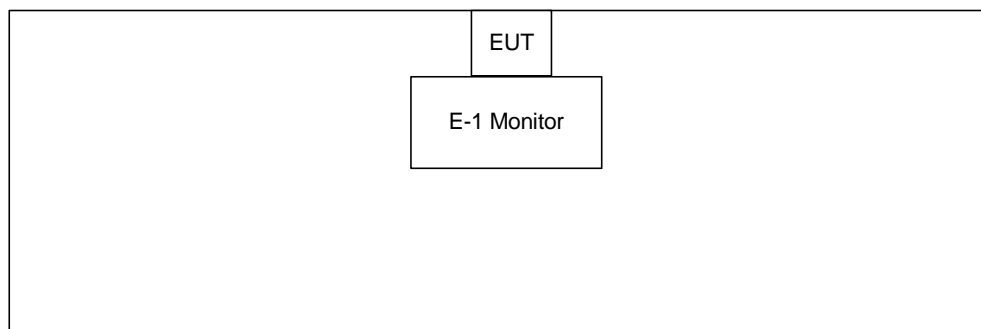

### 3.5 DESCRIPTION OF SUPPORT UNITS

The EUT has been tested as an independent unit together with other necessary accessories or support units. The following support units or accessories were used to form a representative test configuration during the tests.

Item	Equipment	Mfr/Brand	Model/Type No.	FCC ID/IC	Series No.	Note
E-1	24" LCD Monitor	DELL	2408WFPb	DOC	071863-11	

Item	Shielded Type	Ferrite Core	Length	Note
-	-	-	-	-

Note:

- (1) For detachable type I/O cable should be specified the length in m in 『Length』 column.

## 4. EMC EMISSION TEST

### 4.1 CONDUCTED EMISSION MEASUREMENT

#### 4.1.1 POWER LINE CONDUCTED EMISSION Limits (Frequency Range 150KHz-30MHz)

Frequency of Emission (MHz)	Conducted Limit (dB $\mu$ V)	
	Quasi-peak	Average
0.15 -0.5	66 to 56*	56 to 46*
0.50 -5.0	56	46
5.0 -30.0	60	50

Note:

(1) The limit of " \* " decreases with the logarithm of the frequency

The following table is the setting of the receiver

Receiver Parameters	Setting
Attenuation	10 dB
Start Frequency	0.15 MHz
Stop Frequency	30 MHz
IF Bandwidth	9 kHz

#### 4.1.2 TEST PROCEDURE

- a. The EUT was placed 0.8 meters from the horizontal ground plane with EUT being connected to the power mains through a line impedance stabilization network (LISN). All other support equipments powered from additional LISN(s). The LISN provide 50 Ohm/ 50uH of coupling impedance for the measuring instrument.
- b. Interconnecting cables that hang closer than 40 cm to the ground plane shall be folded back and forth in the center forming a bundle 30 to 40 cm long.
- c. I/O cables that are not connected to a peripheral shall be bundled in the center. The end of the cable may be terminated, if required, using the correct terminating impedance. The overall length shall not exceed 1 m.
- d. LISN at least 80 cm from nearest part of EUT chassis.
- e. For the actual test configuration, please refer to the related Item –EUT Test Photos.

#### 4.1.3 DEVIATION FROM TEST STANDARD

No deviation

#### 4.1.4 TEST SETUP

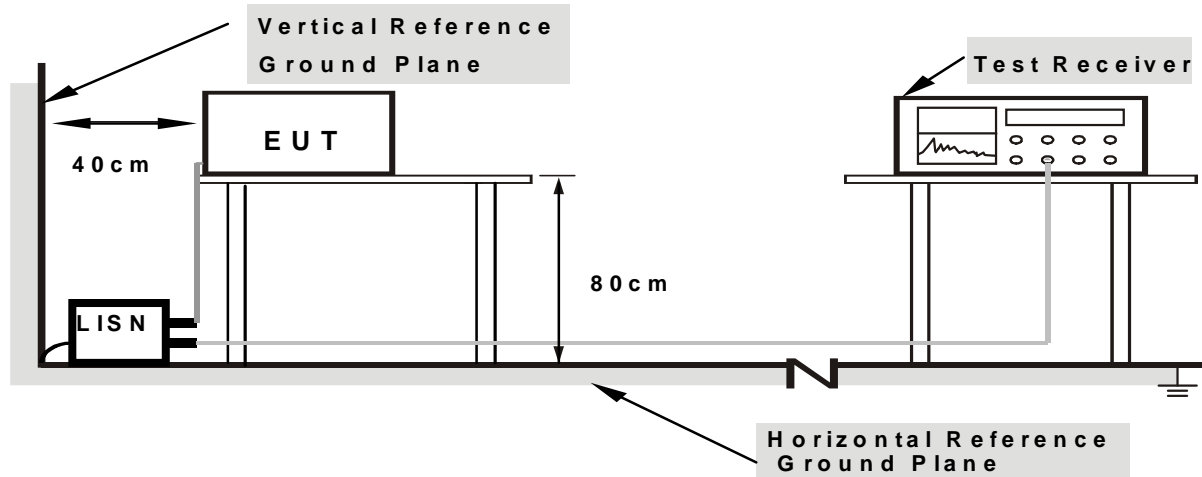

- Note:**
1. Support units were connected to second LISN.
  2. Both of LISNs (AMN) are 80 cm from EUT and at least 80 from other units and other metal planes

#### 4.1.5 EUT OPERATING CONDITIONS

The EUT was configured for testing in a typical fashion (as a customer would normally use it). The EUT has been programmed to continuously transmit during test. This operating condition was tested and used to collect the included data.

#### 4.1.6 EUT TEST CONDITIONS

Temperature: 24°C  
 Relative Humidity: 59%  
 Test Voltage: AC 120V/60Hz

#### 4.1.7 TEST RESULTS

**Please refer to the Attachment A.**

Remark:

- (1) All readings are QP Mode value unless otherwise stated AVG in column of Note. If the QP Mode Measured value compliance with the QP Limits and lower than AVG Limits, the EUT shall be deemed to meet both QP & AVG Limits and then only QP Mode was measured, but AVG Mode didn't perform. In this case, a " \* " marked in AVG Mode column of Interference Voltage Measured.
- (2) Measuring frequency range from 150KHz to 30MHz.
- (3) " N/A" denotes test is not applicable to this device.

## 4.2 RADIATED EMISSION MEASUREMENT

### 4.2.1 RADIATED EMISSION LIMITS (Frequency Range 9KHz-1000MHz)

20dBc in any 100 kHz bandwidth outside the operating frequency band. In case the emission fall within the restricted band specified on 15.205(a), then the 15.209(a) limit in the table below has to be followed.

Frequencies (MHz)	Field Strength (microvolts/meter)	Measurement Distance (meters)
0.009~0.490	2400/F(KHz)	300
0.490~1.705	24000/F(KHz)	30
1.705~30.0	30	30
30~88	100	3
88~216	150	3
216~960	200	3
960~1000	500	3

Section 15.33 Frequency range of radiated measurements.

Unless otherwise noted in the specific rule section under which the equipment operates for an intentional radiator the spectrum shall be investigated from the lowest radio frequency signal generated in the device, without going below 9 kHz, up to at least the frequency shown in this paragraph:

- (1) If the intentional radiator operates below 10 GHz: to the tenth harmonic of the highest fundamental frequency or to 40 GHz, whichever is lower.
- (2) If the intentional radiator operates at or above 10 GHz and below 30 GHz: to the fifth harmonic of the highest fundamental frequency or to 100 GHz, whichever is lower.
- (3) If the intentional radiator operates at or above 30 GHz: to the fifth harmonic of the highest fundamental frequency or to 200 GHz, whichever is lower, unless specified otherwise elsewhere in the rules
- (4) If the intentional radiator contains a digital device, regardless of whether this digital device controls the functions of the intentional radiator or the digital device is used for additional control or function purposes other than to enable the operation of the intentional radiator, the frequency range shall be investigated up to the range specified in paragraphs (a)(1)-(a)(3) of this section or the range applicable to the digital device, as shown in paragraph (b)(1) of this Section, whichever is the higher frequency range of investigation.

Spectrum Parameter	Setting
Attenuation	Auto
Start Frequency	1000 MHz
Stop Frequency	10th carrier harmonic
RBW / VBW (Emission in restricted band)	1MHz / 1MHz for Peak, 1 MHz / 10Hz for Average

Receiver Parameter	Setting
Attenuation	Auto
Start ~ Stop Frequency	9kHz~90kHz for PK/AVG detector
Start ~ Stop Frequency	90kHz~110kHz for QP detector
Start ~ Stop Frequency	110kHz~490kHz for PK/AVG detector
Start ~ Stop Frequency	490kHz~30MHz for QP detector
Start ~ Stop Frequency	30MHz~1000MHz for QP detector

#### 4.2.2 TEST PROCEDURE

- a. The EUT was placed on the top of a rotating table 0.8 meters above the ground at a 3 meter semi-anechoic chamber. The table was rotated 360 degrees to determine the position of the highest radiation.(below 1GHz)
- b. The EUT was placed on the top of a rotating table 0.8 meters above the ground at a 3 meter fully-anechoic chamber. The table was rotated 360 degrees to determine the position of the highest radiation.(above 1GHz)
- c. The height of the equipment or of the substitution antenna shall be 0.8 m; the height of the test antenna shall vary between 1 m to 4 m. Both horizontal and vertical polarizations of the antenna are set to make the measurement.
- d. The initial step in collecting conducted emission data is a spectrum analyzer peak detector mode pre-scanning the measurement frequency range. Significant peaks are then marked and then Quasi Peak detector mode re-measured.
- e. If the Peak Mode measured value compliance with and lower than Quasi Peak Mode Limit, the EUT shall be deemed to meet QP Limits and then no additional QP Mode measurement performed.
- f. For the actual test configuration, please refer to the related Item –EUT Test Photos.

#### 4.2.3 DEVIATION FROM TEST STANDARD

No deviation

#### 4.2.4 TEST SETUP

(A) Radiated Emission Test Set-Up Frequency Below 1 GHz

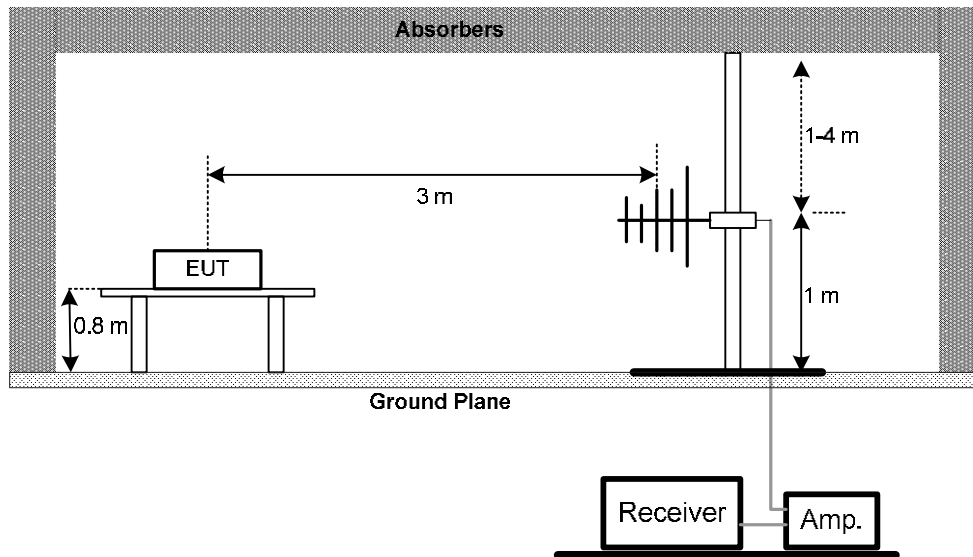

(B) Radiated Emission Test Set-Up Frequency Above 1 GHz

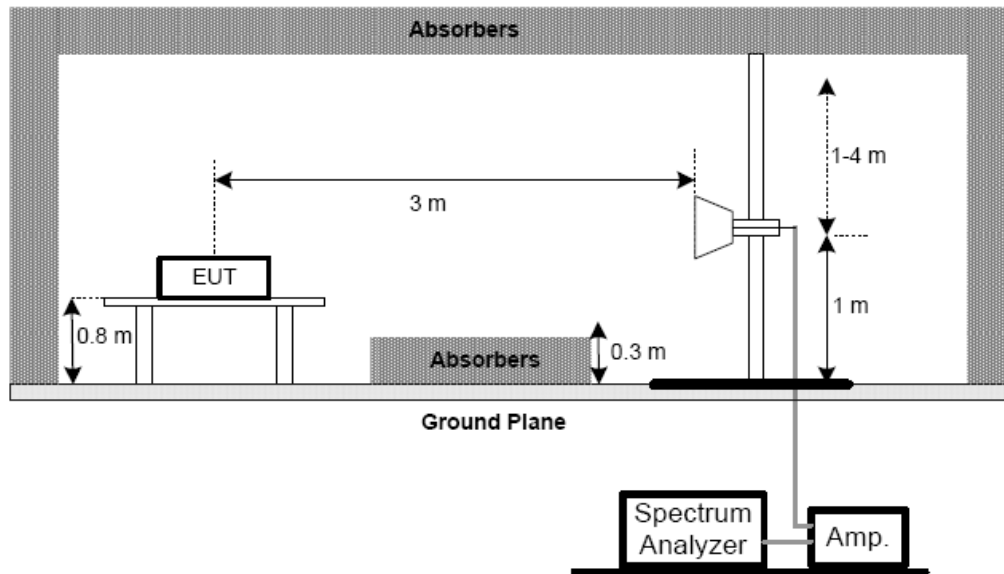



(C) For radiated emissions below 30MHz

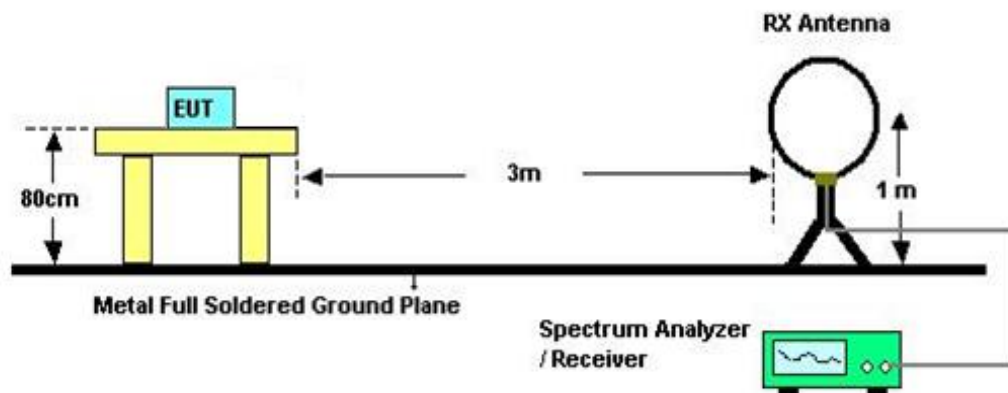

#### 4.2.5 EUT OPERATING CONDITIONS

The EUT tested system was configured as the statements of 4.1.5 Unless otherwise a special operating condition is specified in the follows during the testing.

#### 4.2.6 EUT TEST CONDITIONS

Temperature: 20°C

Relative Humidity: 65%

**Test Voltage:** AC 120V/60Hz

#### 4.2.7 TEST RESULTS (9KHZ TO 30MHZ)

**Please refer to the Attachment B**

Remark:

- (1) The amplitude of spurious emissions which are attenuated by more than 20 dB below the permissible value has no need to be reported.
- (2) Distance extrapolation factor =  $40 \log(\text{specific distance} / \text{test distance})$  (dB).
- (3) Limit line = specific limits (dBuV) + distance extrapolation factor.

#### **4.2.8 TEST RESULTS (BETWEEN 30MHZ TO 1000 MHZ)**

**Please refer to the Attachment C.**

Remark:

- (1) Reading in which marked as QP or Peak means measurements by using are Quasi-Peak Mode or Peak Mode with Detector BW=120KHz ; SPA setting in RBW=120KHz, VBW =120KHz, Swp. Time = 0.3 sec./MHz.
- (2) All readings are Peak unless otherwise stated QP in column of 『Note 』 . Peak denotes that the Peak reading compliance with the QP Limits and then QP Mode measurement didn't perform.
- (3) Measuring frequency range from 30MHz to 1000MHz.
- (4) If the peak scan value lower limit more than 20dB, then this signal data does not show in table.

#### **4.2.9 TEST RESULTS (ABOVE 1000 MHZ)**

**Please refer to the Attachment D.**

Remark:

- (1) All readings are Peak unless otherwise stated QP in column of 『Note 』 . Peak denotes that the Peak reading compliance with the QP Limits and then QP Mode measurement didn't perform.
- (2) Radiated emissions measured in frequency range above 1000MHz were made with an instrument using Peak detector mode and AV detector mode of the emission
- (3) A preamp and high pass filter were used for this test in order to provide sufficient measurement sensitivity.
- (4) EUT Orthogonal Axis:  
"X" - denotes Laid on Table ; "Y" - denotes Vertical Stand ; "Z" - denotes Side Stand
- (5) During the measurements above 1 GHz it is taken care of that the EUT is always within the 3 dB cone of radiation BW of the used antenna
- (6) No limit: This is fundamental signal, the judgment is not applicable.  
For fundamental signal judgment was referred to Peak output test.

## 5. BANDWIDTH TEST

### 5.1 Applied procedures / limit

FCC Part15 (15.247) , Subpart C				
Section	Test Item	Limit	Frequency Range (MHz)	Result
15.247(a)(2)	Bandwidth	$\geq 500\text{KHz}$ (6dB bandwidth)	2400-2483.5	PASS

#### 5.1.1 TEST PROCEDURE

- a. The EUT was directly connected to the spectrum analyzer and antenna output port as show in the block diagram below,
- b. Spectrum Setting : RBW= 100KHz, VBW=300KHz, Sweep time = 2.5 ms.

#### 5.1.2 DEVIATION FROM STANDARD

No deviation.

#### 5.1.3 TEST SETUP



#### 5.1.4 EUT OPERATION CONDITIONS

The EUT tested system was configured as the statements of 4.1.5 Unless otherwise a special operating condition is specified in the follows during the testing.

#### 5.1.5 EUT TEST CONDITIONS

Temperature: 25°C  
 Relative Humidity: 55%  
 Test Voltage: AC 120V/60Hz

#### 5.1.6 TEST RESULTS

Please refer to the Attachment E.

## 6. MAXIMUM OUTPUT POWER TEST

### 6.1 Applied procedures / limit

FCC Part15 (15.247) , Subpart C				
Section	Test Item	Limit	Frequency Range (MHz)	Result
15.247(b)(3)	Maximum Output Power	1 watt or 30dBm	2400-2483.5	PASS

#### 6.1.1 TEST PROCEDURE

- a. The EUT was directly connected to the power meter and antenna output port as show in the block diagram below,
- b. The maximum peak conducted output power was performed in accordance with method 9.1.2 of FCC KDB 558074 D01 DTS Meas Guidance v03r02.

#### 6.1.2 DEVIATION FROM STANDARD

No deviation.

#### 6.1.3 TEST SETUP



#### 6.1.4 EUT OPERATION CONDITIONS

The EUT tested system was configured as the statements of 4.1.5 Unless otherwise a special operating condition is specified in the follows during the testing. Transmit output power was measured while the host equipment supply voltage was varied from 85 % to 115 % of the nominal rated supply voltage. No change in transmit output power was observed.

#### 6.1.5 EUT TEST CONDITIONS

Temperature: 25°C  
 Relative Humidity: 55%  
 Test Voltage: AC 120V/60Hz

#### 6.1.6 TEST RESULTS

Please refer to the Attachment F.

## **7. ANTENNA CONDUCTED SPURIOUS EMISSION**

### **7.1 Applied procedures / limit**

In any 100 kHz bandwidth outside the frequency band in which the spread spectrum or digitally modulated intentional radiator is operating, the radio frequency power that is produced by the intentional radiator shall be at least 20 dB below that in the 100 kHz bandwidth within the band that contains the highest level of the desired power, based on either an RF conducted measurement, provided the transmitter demonstrates compliance with the peak conducted power limits.

#### **7.1.1 TEST PROCEDURE**

- a. The EUT was directly connected to the spectrum analyzer and antenna output port as show in the block diagram below,
- b. Spectrum Setting : RBW= 100KHz, VBW=300KHz, Sweep time = 10 ms.

#### **7.1.2 DEVIATION FROM STANDARD**

No deviation.

#### **7.1.3 TEST SETUP**

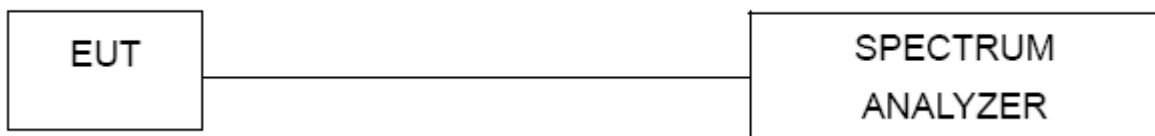

#### **7.1.4 EUT OPERATION CONDITIONS**

The EUT tested system was configured as the statements of 4.1.5 Unless otherwise a special operating condition is specified in the follows during the testing.

#### **7.1.5 EUT OPERATION CONDITIONS**

Temperature: 25°C  
Relative Humidity: 55%  
Test Voltage: AC 120V/60Hz

#### **7.1.6 TEST RESULTS**

**Please refer to the Attachment G.**

## 8. POWER SPECTRAL DENSITY TEST

### 8.1 Applied procedures / limit

FCC Part15 (15.247) , Subpart C				
Section	Test Item	Limit	Frequency Range (MHz)	Result
15.247(e)	Power Spectral Density	8 dBm (in any 3KHz)	2400-2483.5	PASS

#### 8.1.1 TEST PROCEDURE

- a. The EUT was directly connected to the spectrum analyzer and antenna output port as show in the block diagram below,
- b. Spectrum Setting: RBW=3KHz, VBW=10 KHz, Sweep time = auto.

#### 8.1.2 DEVIATION FROM STANDARD

No deviation.

#### 8.1.3 TEST SETUP

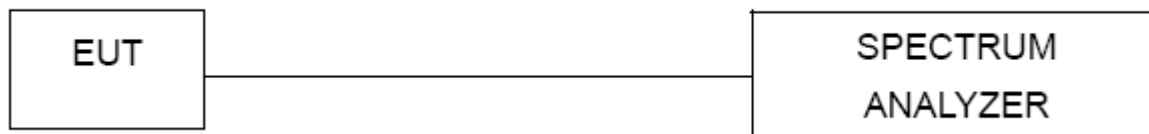

#### 8.1.4 EUT OPERATION CONDITIONS

The EUT tested system was configured as the statements of 4.1.5 Unless otherwise a special operating condition is specified in the follows during the testing.

#### 8.1.5 EUT TEST CONDITIONS

Temperature: 25°C  
 Relative Humidity: 55%  
 Test Voltage: AC 120V/60Hz

#### 8.1.6 TEST RESULTS

Please refer to the Attachment H.

## 9. MEASUREMENT INSTRUMENTS LIST

Conducted Emission Measurement					
Item	Kind of Equipment	Manufacturer	Type No.	Serial No.	Calibrated until
1	LISN	R&s	ENV216	100087	Nov. 23, 2014
2	Test Cable	TIMES	CFD300-NL	C01	Jun. 15, 2015
3	EMI Test Receiver	R&S	ESCI	100082	Apr. 13, 2015
4	Measurement Software	EZ	EZ EMC (Version NB-02A)	N/A	N/A

Radiated Emission Measurement					
Item	Kind of Equipment	Manufacturer	Type No.	Serial No.	Calibrated until
1	Spectrum Analyzer	R&S	FSP-40	100129	Oct. 13, 2015
2	Horn Antenna	Schwarzbeck	BBHA 9120	D-325	Jun. 14, 2015
3	Microwave Pre_amplifier	Agilent	8449B	3008A01714	Apr. 15, 2015
4	Microflex Cable	Harbour industries	27478LL142	1m	May. 12, 2015
5	Microflex Cable	EMC	S104-SMA	8m	May. 14, 2015
6	Microflex Cable	Harbour industries	27478LL142	3m	May. 12, 2015
7	Test Cable	LMR	LMR-400	12m	May. 13, 2015
8	Test Cable	LMR	LMR-400	3m	May. 13, 2015
9	Pre-Amplifier	Anritsu	MH648A	M92649	Jun. 17, 2015
10	Log-Bicon Antenna	Schwarzbeck	VULB9168-35 2	9168-352	July. 10, 2015

**Bandwidth**

Item	Kind of Equipment	Manufacturer	Type No.	Serial No.	Calibrated until
1	Spectrum Analyzer	R&S	FSP-40	100129	Oct. 13, 2015

**Peak Output Power**

Item	Kind of Equipment	Manufacturer	Type No.	Serial No.	Calibrated until
1	Spectrum Analyzer	R&S	FSP-40	100129	Oct. 13, 2015

**Antenna Conducted Spurious Emission**

Item	Kind of Equipment	Manufacturer	Type No.	Serial No.	Calibrated until
1	Spectrum Analyzer	R&S	FSP-40	100129	Oct. 13, 2015

Remark: "N/A" denotes no model name, serial no. or calibration specified.  
 All calibration period of equipment list is one year.



**10. EUT TEST PHOTO****Conducted Measurement Photos**

## Radiated Measurement Photos

9KHz-30MHz

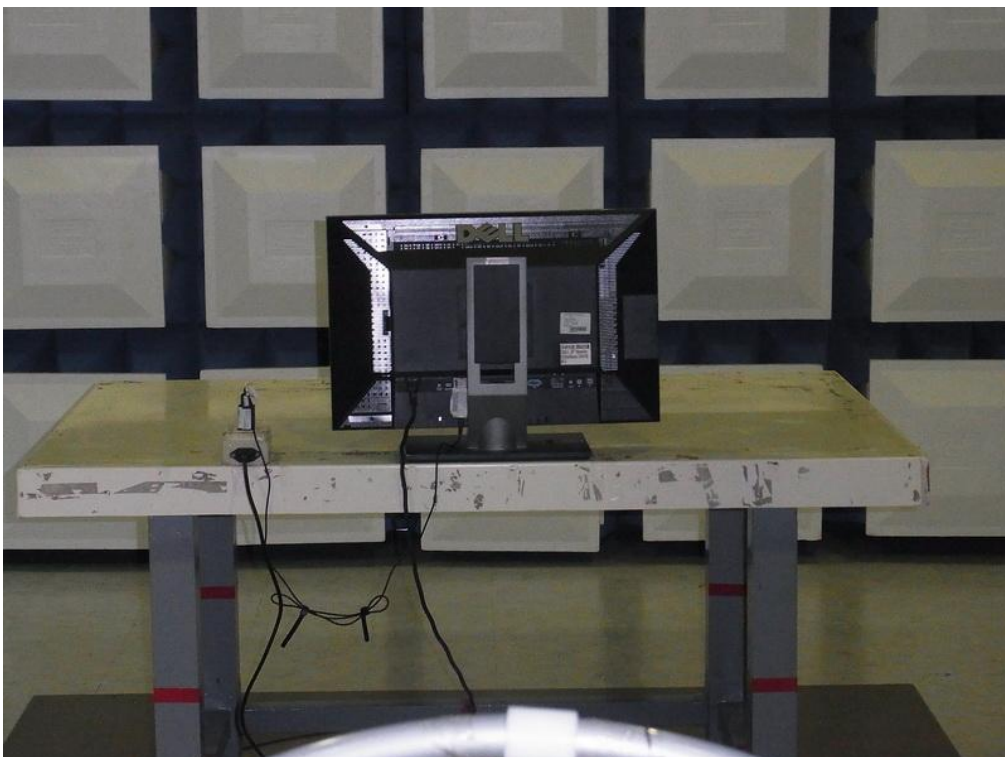

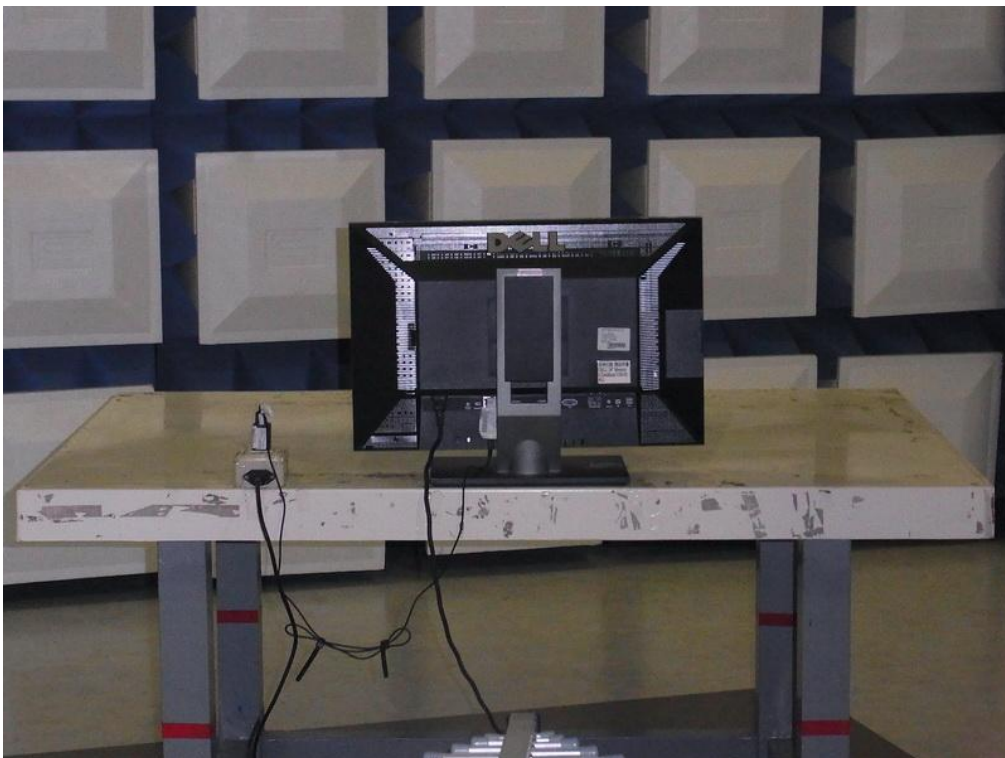
**Radiated Measurement Photos****30MHz-1GHz**

## Radiated Measurement Photos

Above 1GHz

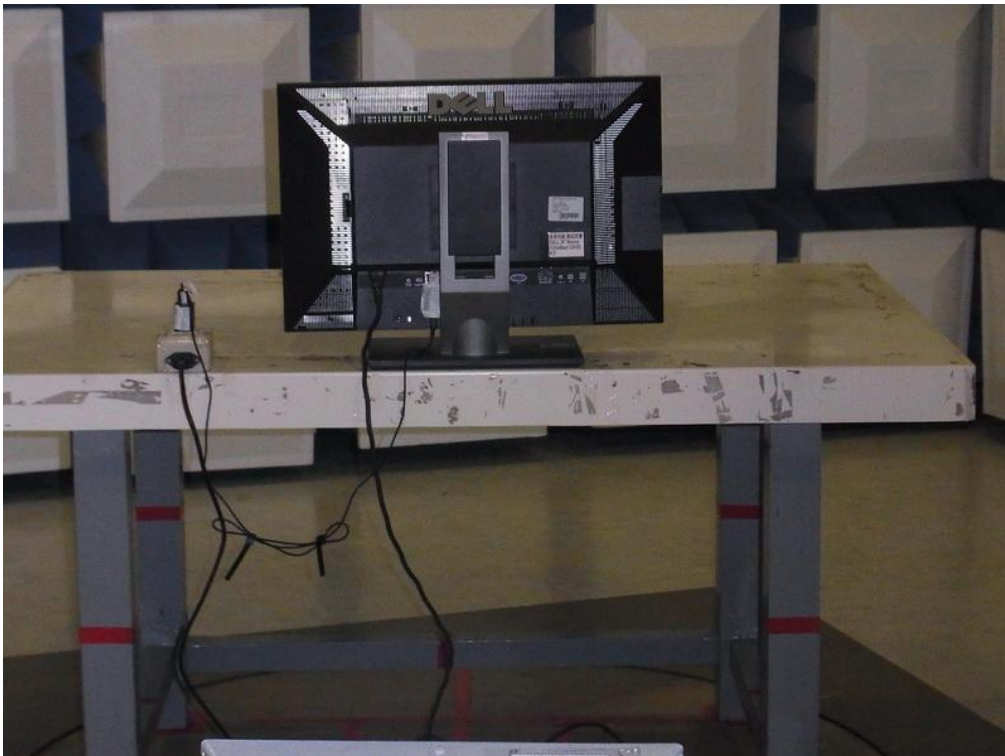

## ATTACHMENT A - CONDUCTED EMISSION

Test Mode: TX Mode

### Line



No.	Mk.	Freq. MHz	Reading Level dBuV	Correct Factor dB	Measure- ment dBuV	Limit dBuV	Over dB	Detector	Comment
1		0.2011	39.03	9.65	48.68	63.56	-14.88	peak	
2	*	0.3345	34.68	9.80	44.48	59.34	-14.86	peak	
3		1.4536	25.49	9.73	35.22	56.00	-20.78	peak	
4		2.0299	25.24	9.77	35.01	56.00	-20.99	peak	
5		4.0187	25.06	9.88	34.94	56.00	-21.06	peak	
6		17.6000	27.02	10.35	37.37	60.00	-22.63	peak	

Test Mode: TX Mode

### Neutral



No.	Mk.	Freq. MHz	Reading Level dBuV	Correct Factor dB	Measure- ment dBuV	Limit dBuV	Over dB	Detector	Comment
1		0.1508	39.19	9.64	48.83	65.95	-17.12	peak	
2		0.1975	36.24	9.64	45.88	63.71	-17.83	peak	
3	*	0.3310	33.29	9.65	42.94	59.42	-16.48	peak	
4		1.4449	27.60	9.72	37.32	56.00	-18.68	peak	
5		4.3428	26.63	9.89	36.52	56.00	-19.48	peak	
6		20.9496	25.09	10.42	35.51	60.00	-24.49	peak	

**ATTACHMENT B - RADIATED EMISSION (9KHZ-30MHZ)**



Test Mode:	TX Mode
------------	---------

Freq. (MHz)	Ant. 0°/90°	Reading(RA) (dBuV)	Corr.Factor(CF) (dB)	Measured(FS) (dBuV/m)	Limits(QP) (dBuV/m)	Margin (dB)	Note
0.2431	0°	55.32	11.20	66.52	119.89	-53.37	PK
0.2431	0°	38.41	11.20	49.61	99.89	-50.28	AVG
0.3778	0°	55.48	10.80	66.28	116.06	-49.78	PK
0.3778	0°	40.39	10.80	51.19	96.06	-44.87	AVG
0.5312	0°	31.24	10.82	42.06	73.10	-31.03	QP
0.5828	0°	33.52	10.87	44.39	72.29	-27.91	QP
0.7620	0°	32.51	11.01	43.52	69.97	-26.45	QP
1.1262	0°	32.75	11.23	43.98	66.57	-22.59	QP

Freq. (MHz)	Ant. 0°/90°	Reading(RA) (dBuV)	Corr.Factor(CF) (dB)	Measured(FS) (dBuV/m)	Limits(QP) (dBuV/m)	Margin (dB)	Note
0.2430	90°	54.95	11.20	66.15	119.89	-53.74	PK
0.2430	90°	37.32	11.20	48.52	99.89	-51.37	AVG
0.3773	90°	57.35	10.80	68.15	116.07	-47.92	PK
0.3773	90°	40.62	10.80	51.42	96.07	-44.65	AVG
0.5305	90°	33.14	10.82	43.96	73.11	-29.15	QP
0.5831	90°	33.84	10.87	44.71	72.29	-27.58	QP
0.7590	90°	31.18	11.01	42.19	70.00	-27.81	QP
1.1249	90°	31.60	11.23	42.83	66.58	-23.75	QP

**ATTACHMENT C - RADIATED EMISSION BETWEEN 30MHZ AND  
1000MHZ)**

Test Mode: TX 2440MHz -CH19 -1Mbps

Vertical



No. Mk.	Freq. MHz	Reading Level dBuV	Correct Factor dB	Measure- ment dBuV/m	Limit dBuV/m	Over dB	Detector	Comment
1	46.9750	47.37	-13.68	33.69	40.00	-6.31	peak	
2 *	114.8750	56.64	-16.78	39.86	43.50	-3.64	peak	
3	153.6750	50.76	-14.00	36.76	43.50	-6.74	peak	
4	311.3000	47.66	-13.18	34.48	46.00	-11.52	peak	
5	595.0250	43.01	-7.51	35.50	46.00	-10.50	peak	
6	742.9500	45.36	-5.07	40.29	46.00	-5.71	peak	

Test Mode: TX 2440MHz -CH19 -1Mbps

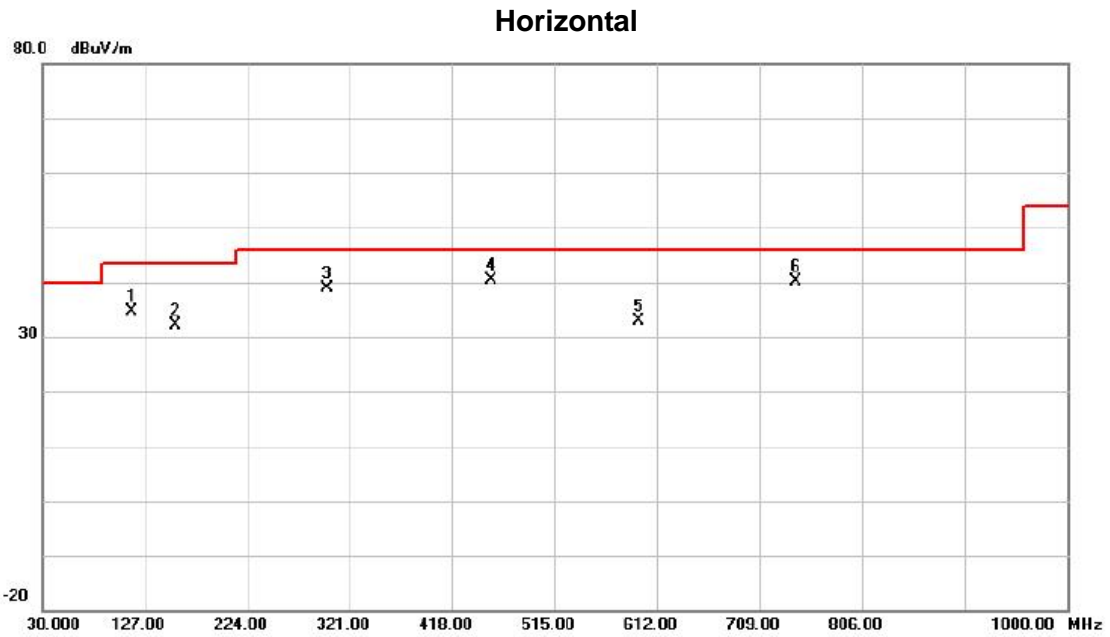

No.	Mk.	Freq. MHz	Reading Level dBuV	Correct Factor dB	Measure- ment dBuV/m	Limit dBuV/m	Over dB	Detector	Comment
1		114.8750	51.39	-16.78	34.61	43.50	-8.89	peak	
2		156.1000	46.07	-13.97	32.10	43.50	-11.40	peak	
3		299.1750	52.46	-13.51	38.95	46.00	-7.05	peak	
4	*	454.3750	50.12	-9.63	40.49	46.00	-5.51	peak	
5		595.0250	40.47	-7.51	32.96	46.00	-13.04	peak	
6		742.9500	45.12	-5.07	40.05	46.00	-5.95	peak	

**ATTACHMENT D - RADIATED EMISSION (ABOVE 1000MHZ)**

Orthogonal Axis :	X
Test Mode :	TX 2402MHz _CH00_1Mbps

### Vertical

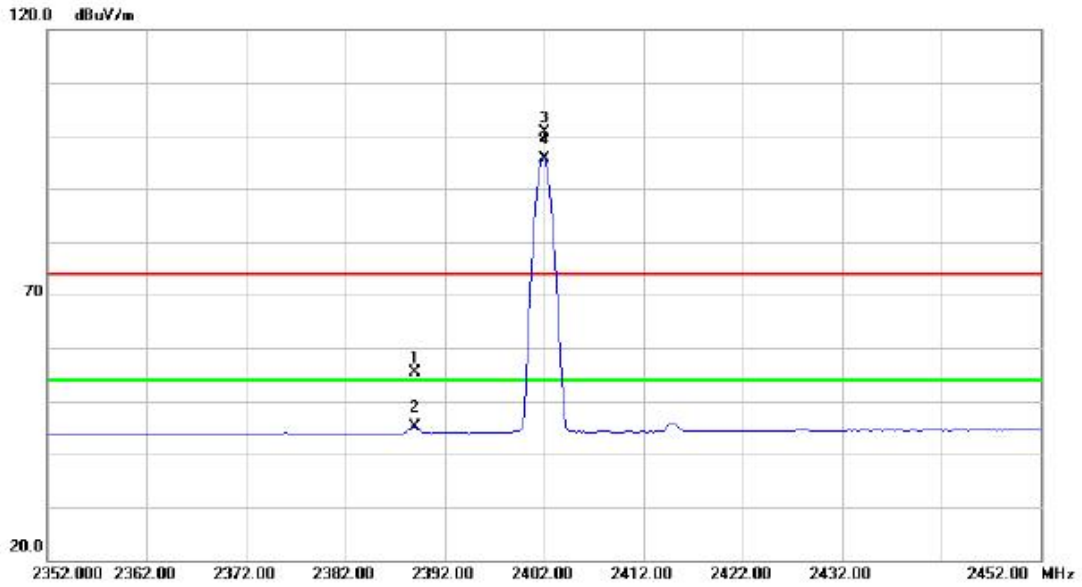

No.	Mk.	Freq. MHz	Reading Level dBuV	Correct Factor dB	Measure- ment dBuV/m	Limit dBuV/m	Over dB	Detector	Comment
1		2389.000	24.30	31.01	55.31	74.00	-18.69	peak	
2		2389.000	14.11	31.01	45.12	54.00	-8.88	AVG	
3	X	2402.000	69.60	31.08	100.68	74.00	26.68	peak	No Limit
4	*	2402.000	64.67	31.08	95.75	54.00	41.75	AVG	No Limit

Orthogonal Axis :	X
Test Mode :	TX 2402MHz _CH00_1Mbps

### Vertical

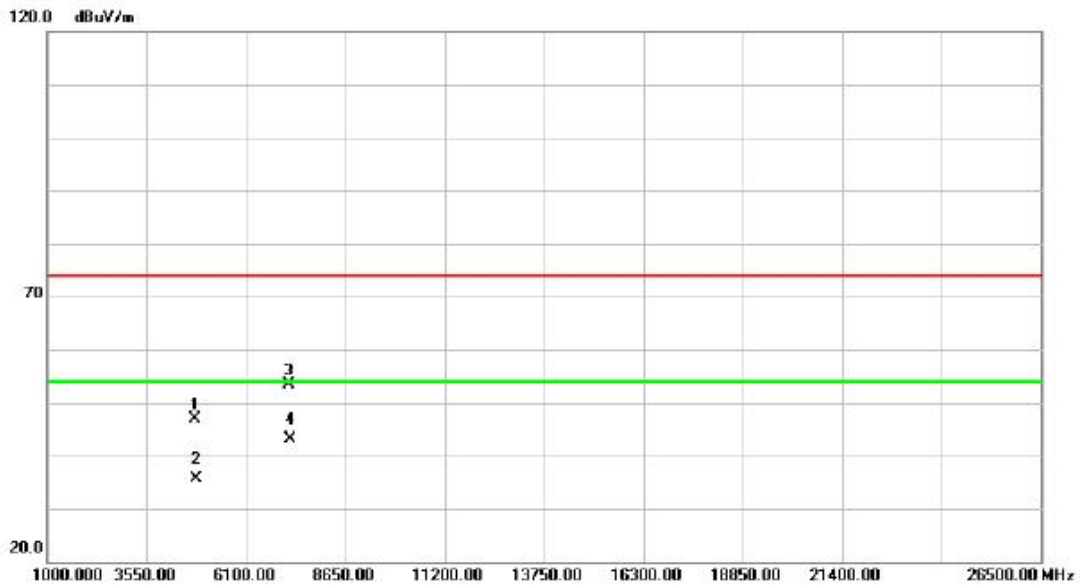

No. Mk.	Freq. MHz	Reading Level dBuV	Correct Factor dB	Measure- ment dBuV/m	Limit dBuV/m	Over dB	Detector	Comment
1	4803.660	42.01	4.94	46.95	74.00	-27.05	peak	
2	4803.660	30.64	4.94	35.58	54.00	-18.42	AVG	
3	7205.745	40.86	12.40	53.26	74.00	-20.74	peak	
4 *	7205.745	30.73	12.40	43.13	54.00	-10.87	AVG	

Orthogonal Axis :	X
Test Mode :	TX 2402MHz _CH00_1Mbps

### Horizontal

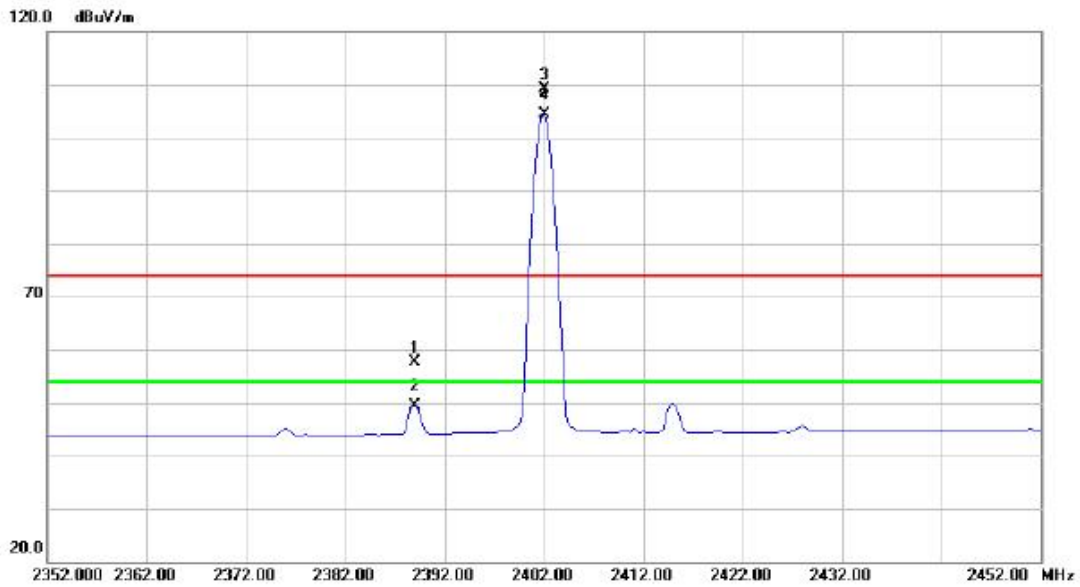

No.	Mk.	Freq. MHz	Reading Level dBuV	Correct Factor dB	Measure- ment dBuV/m	Limit dBuV/m	Over dB	Detector	Comment
1		2389.000	26.74	31.01	57.75	74.00	-16.25	peak	
2		2389.000	18.45	31.01	49.46	54.00	-4.54	AVG	
3	X	2402.000	78.10	31.08	109.18	74.00	35.18	peak	No Limit
4	*	2402.000	73.24	31.08	104.32	54.00	50.32	AVG	No Limit



Orthogonal Axis :	X
Test Mode :	TX 2402MHz _CH00_1Mbps

### Horizontal

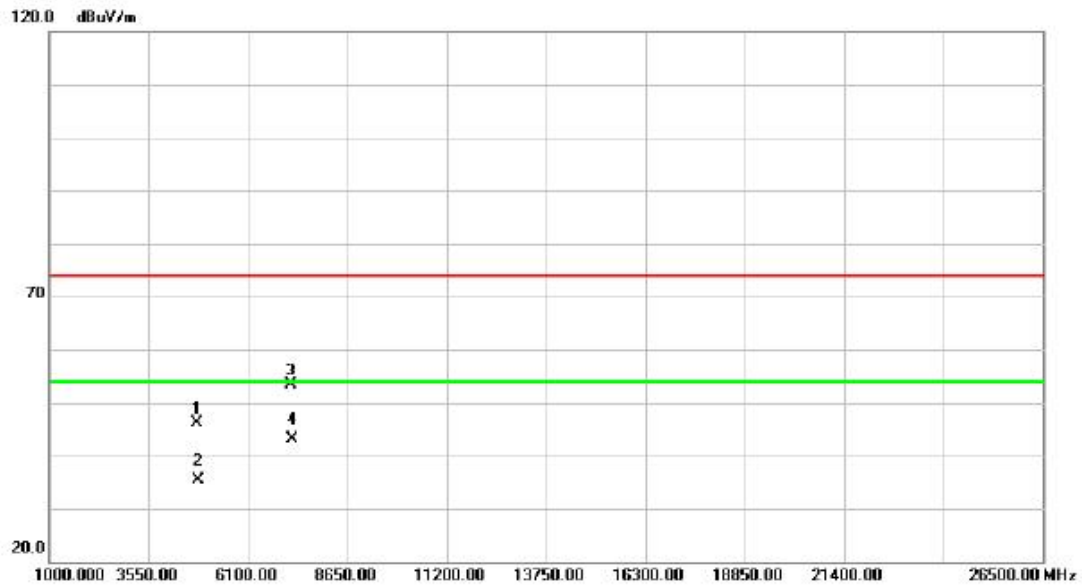

No. Mk.	Freq. MHz	Reading Level dBuV	Correct Factor dB	Measure- ment dBuV/m	Limit dBuV/m	Over dB	Detector	Comment
1	4803.690	41.16	4.94	46.10	74.00	-27.90	peak	
2	4803.690	30.32	4.94	35.26	54.00	-18.74	AVG	
3	7206.075	41.07	12.40	53.47	74.00	-20.53	peak	
4 *	7206.075	30.70	12.40	43.10	54.00	-10.90	AVG	

Orthogonal Axis :	X
Test Mode :	TX 2440MHz_CH19_1Mbps

### Vertical

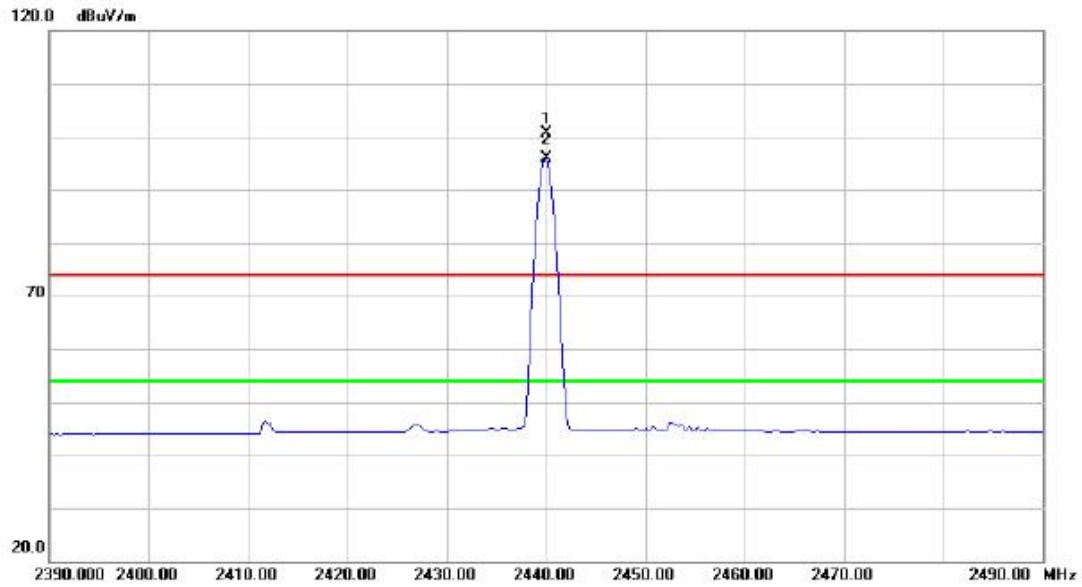

No.	Mk.	Freq.	Reading Level	Correct Factor	Measurement	Limit	Over	Detector	Comment
		MHz	dBuV	dB	dBuV/m	dBuV/m	dB		
1	X	2440.000	69.45	31.26	100.71	74.00	26.71	peak	No Limit
2	*	2440.000	64.53	31.26	95.79	54.00	41.79	AVG	No Limit

Orthogonal Axis :	X
Test Mode :	TX 2440MHz _CH19_1Mbps

### Vertical

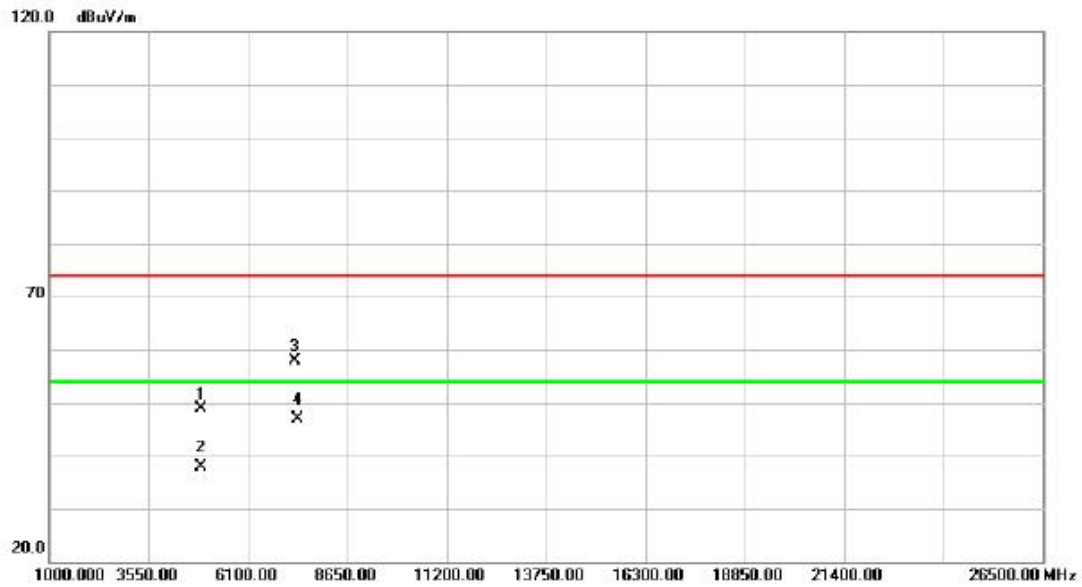

No. Mk.	Freq. MHz	Reading Level dBuV	Correct Factor dB	Measure- ment dBuV/m	Limit dBuV/m	Over dB	Detector	Comment
1	4879.645	42.11	6.77	48.88	74.00	-25.12	peak	
2	4879.645	31.03	6.77	37.80	54.00	-16.20	AVG	
3	7319.920	42.17	15.62	57.79	74.00	-16.21	peak	
4 *	7319.920	31.32	15.62	46.94	54.00	-7.06	AVG	

Orthogonal Axis :	X
Test Mode :	TX 2440MHz _CH19_1Mbps

### Horizontal

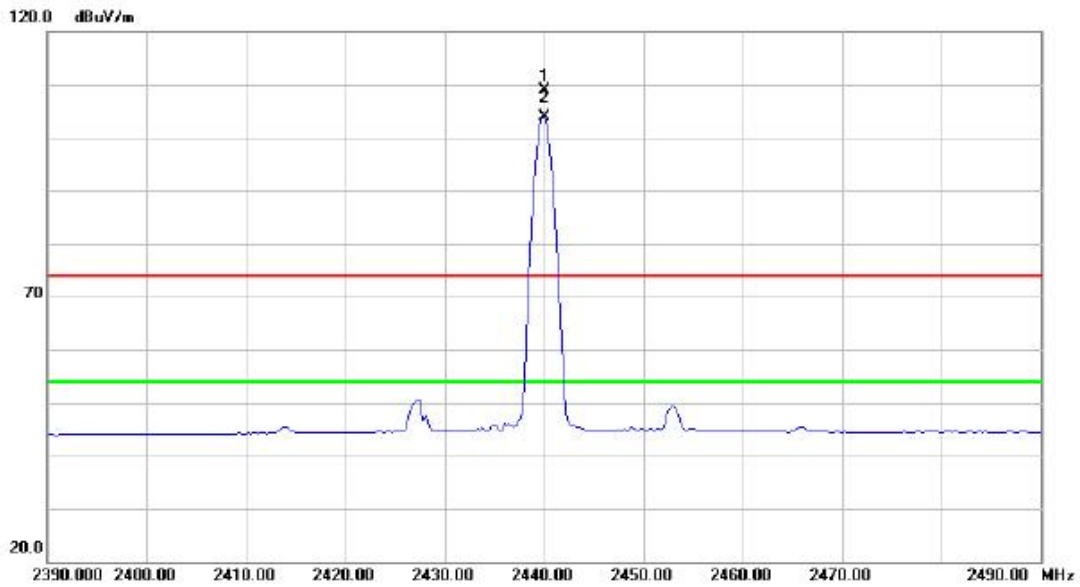

No.	Mk.	Freq.	Reading Level	Correct Factor	Measurement	Limit	Over	Detector	Comment
		MHz	dBuV	dB	dBuV/m	dBuV/m	dB		
1	X	2440.000	77.68	31.26	108.94	74.00	34.94	peak	No Limit
2	*	2440.000	72.67	31.26	103.93	54.00	49.93	AVG	No Limit

Orthogonal Axis :	X
Test Mode :	TX 2440MHz _CH19_1Mbps

### Horizontal

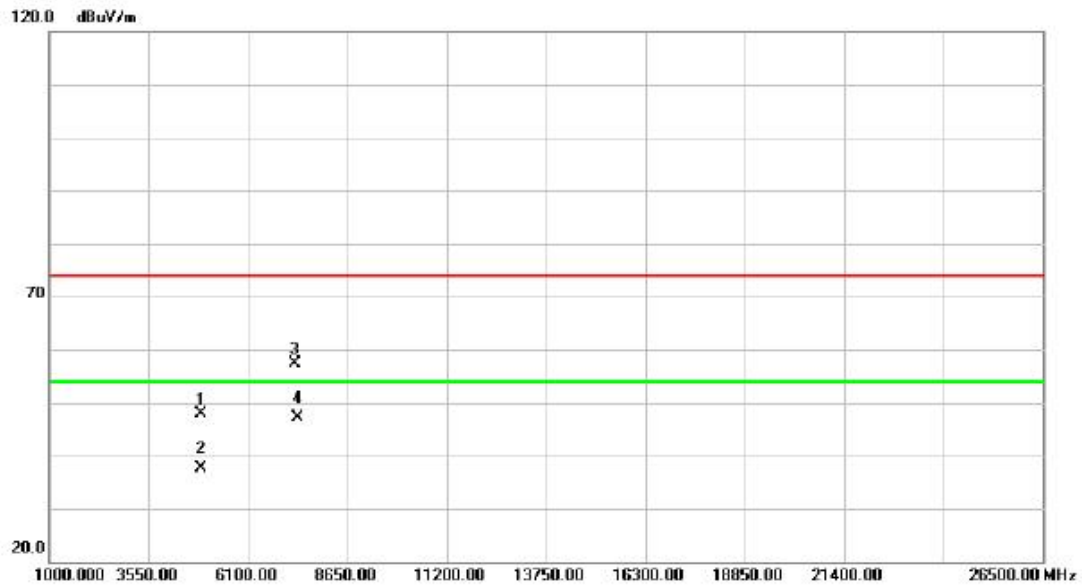

No. Mk.	Freq. MHz	Reading Level dBuV	Correct Factor dB	Measure- ment dBuV/m	Limit dBuV/m	Over dB	Detector	Comment
1	4879.975	41.01	6.77	47.78	74.00	-26.22	peak	
2	4879.975	30.85	6.77	37.62	54.00	-16.38	AVG	
3	7320.110	41.76	15.62	57.38	74.00	-16.62	peak	
4 *	7320.110	31.63	15.62	47.25	54.00	-6.75	AVG	

Orthogonal Axis :	X
Test Mode :	TX 2480MHz_CH39_1Mbps

### Vertical

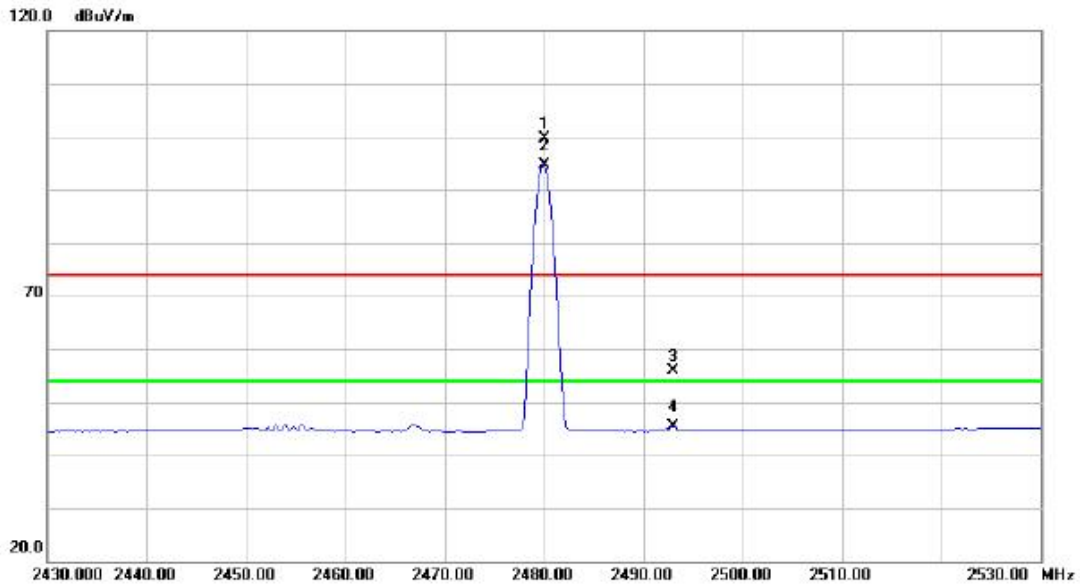

No.	Mk.	Freq. MHz	Reading Level dBuV	Correct Factor dB	Measure- ment dBuV/m	Limit dBuV/m	Over dB	Detector	Comment
1	X	2480.000	68.20	31.44	99.64	74.00	25.64	peak	No Limit
2	*	2480.000	63.28	31.44	94.72	54.00	40.72	AVG	No Limit
3		2493.000	24.40	31.51	55.91	74.00	-18.09	peak	
4		2493.000	13.89	31.51	45.40	54.00	-8.60	AVG	

Orthogonal Axis :	X
Test Mode :	TX 2480MHz _CH39_1Mbps

### Vertical

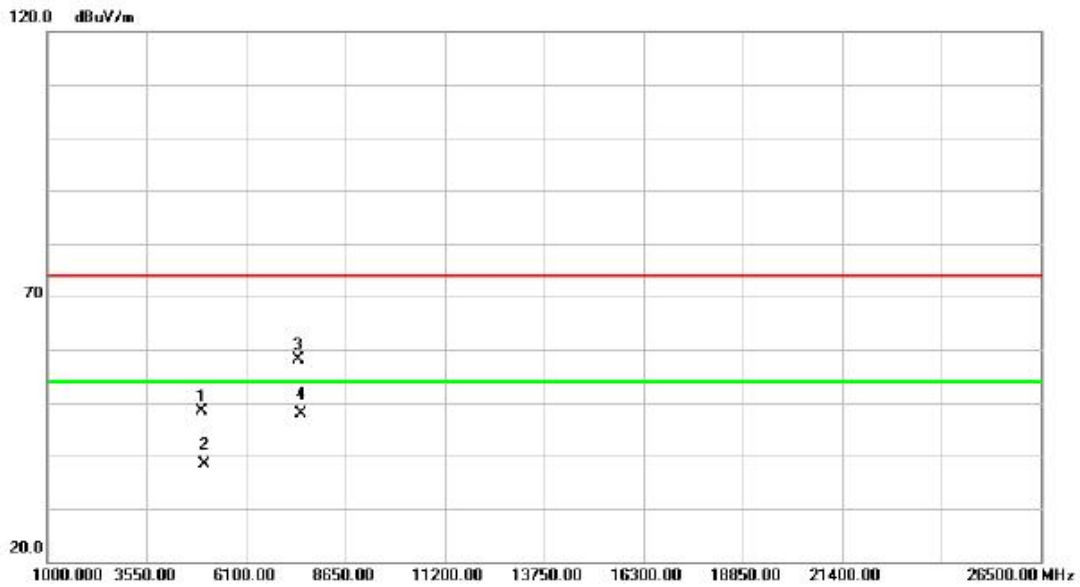

No. Mk.	Freq. MHz	Reading Level dBuV	Correct Factor dB	Measure- ment dBuV/m	Limit dBuV/m	Over dB	Detector	Comment
1	4959.725	41.66	6.76	48.42	74.00	-25.58	peak	
2	4959.725	31.54	6.76	38.30	54.00	-15.70	AVG	
3	7439.660	41.74	16.28	58.02	74.00	-15.98	peak	
4 *	7439.660	31.56	16.28	47.84	54.00	-6.16	AVG	

Orthogonal Axis :	X
Test Mode :	TX 2480MHz _CH39_1Mbps

### Horizontal

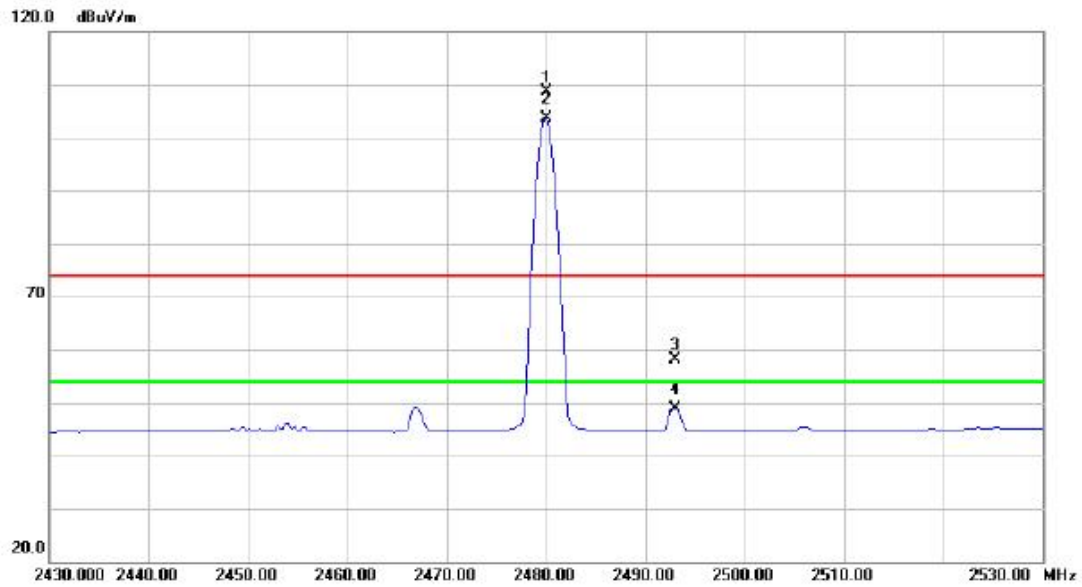

No.	Mk.	Freq. MHz	Reading Level dBuV	Correct Factor dB	Measure- ment dBuV/m	Limit dBuV/m	Over dB	Detector	Comment
1	X	2480.000	77.20	31.44	108.64	74.00	34.64	peak	No Limit
2	*	2480.000	72.14	31.44	103.58	54.00	49.58	AVG	No Limit
3		2493.000	26.55	31.51	58.06	74.00	-15.94	peak	
4		2493.000	17.40	31.51	48.91	54.00	-5.09	AVG	



Orthogonal Axis :	X
Test Mode :	TX 2480MHz _CH39_1Mbps

### Horizontal

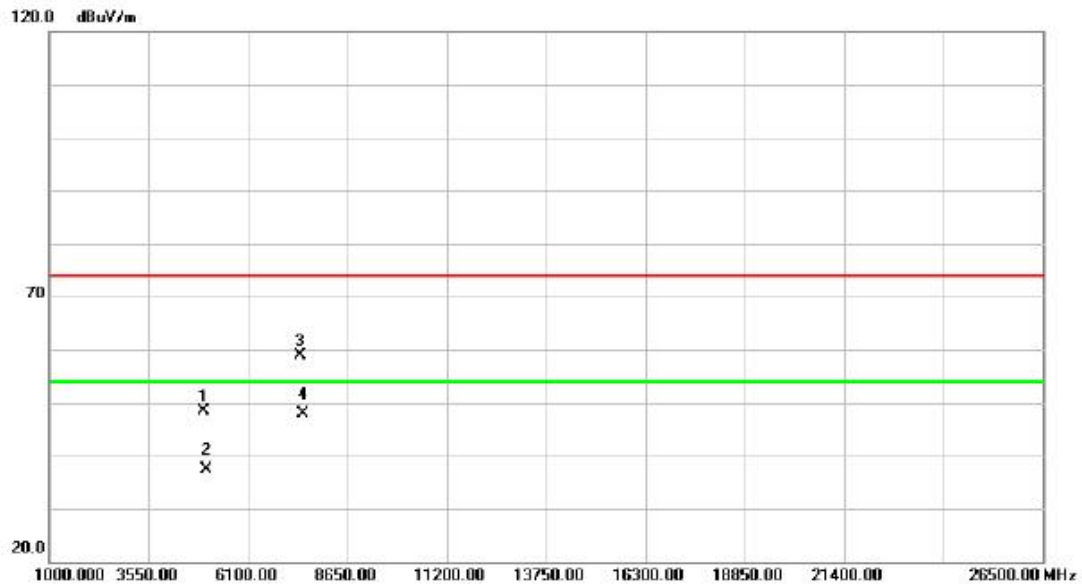

No. Mk.	Freq. MHz	Reading Level dBuV	Correct Factor dB	Measure- ment dBuV/m	Limit dBuV/m	Over dB	Detector	Comment
1	4960.190	41.74	6.76	48.50	74.00	-25.50	peak	
2	4960.190	30.54	6.76	37.30	54.00	-16.70	AVG	
3	7439.870	42.62	16.28	58.90	74.00	-15.10	peak	
4 *	7439.870	31.58	16.28	47.86	54.00	-6.14	AVG	

## ATTACHMENT E - BANDWIDTH

Frequency (MHz)	6dB Bandwidth (MHz)	99% Occupied BW (MHz)	Min. Limit (kHz)	Test Result
2402	0.711	1.061	500	Complies
2440	0.733	1.058	500	Complies
2480	0.733	1.061	500	Complies

### TX CH00

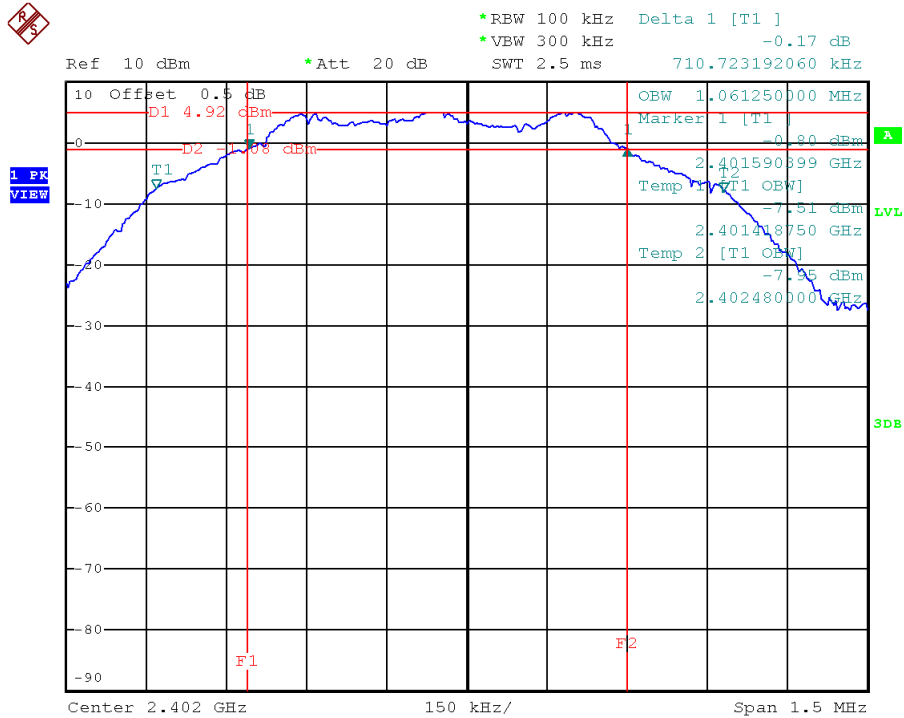

Date: 29.OCT.2014 14:44:51

### TX CH19

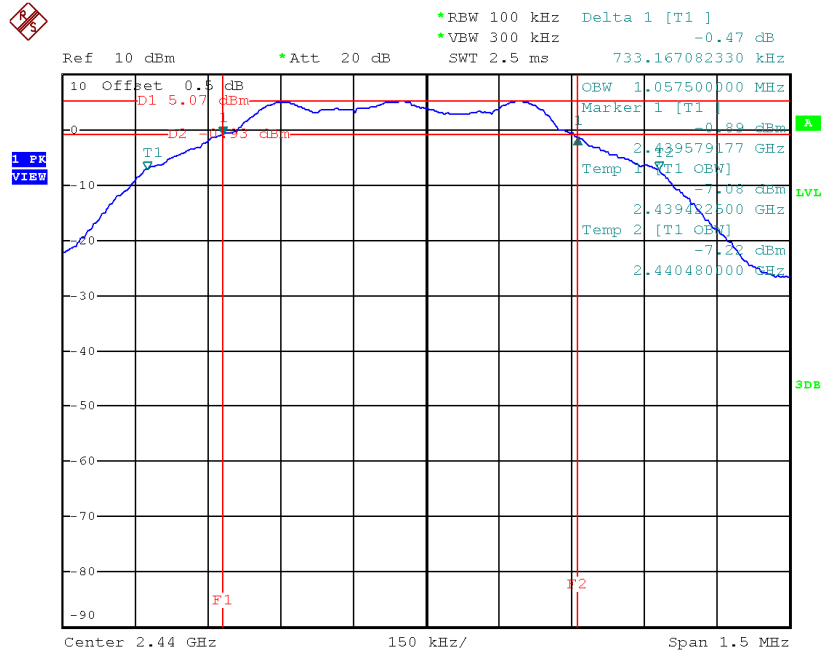

Date: 29.OCT.2014 14:51:06

### TX CH39

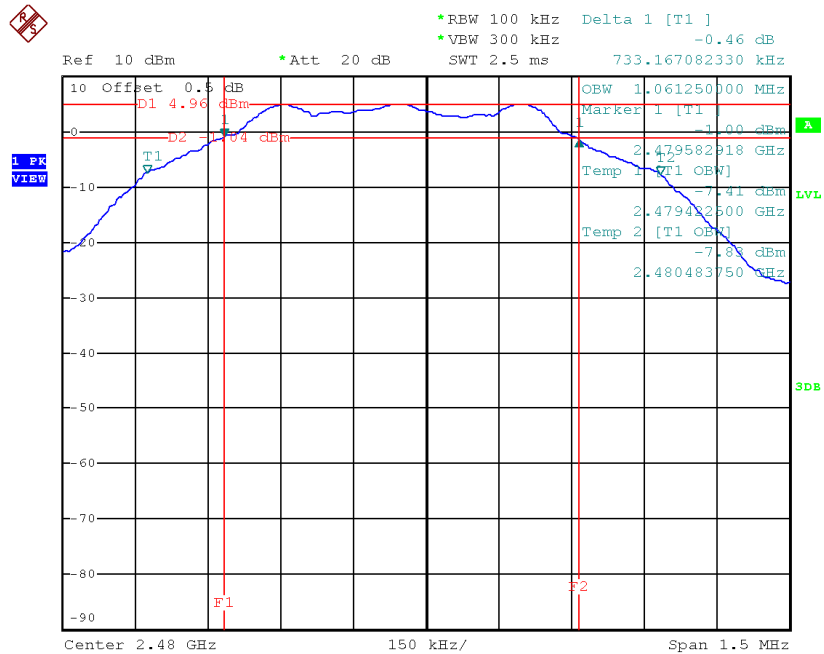

Date: 29.OCT.2014 14:54:34

## ATTACHMENT F - MAXIMUM OUTPUT POWER TEST

Frequency (MHz)	Conducted Power (dBm)	Conducted Power (Watt)	Max. Limit (dBm)	Max. Limit (Watt)	Test Result
2402	2.56	0.0018	30.00	1.00	Complies
2440	2.68	0.0019	30.00	1.00	Complies
2480	2.51	0.0018	30.00	1.00	Complies

**ATTACHMENT G - ANTENNA CONDUCTED SPURIOUS  
EMISSION**

Test Mode : CH00, CH19 , CH39 - 1Mbps

### CH00 (Lower) - 1Mbps

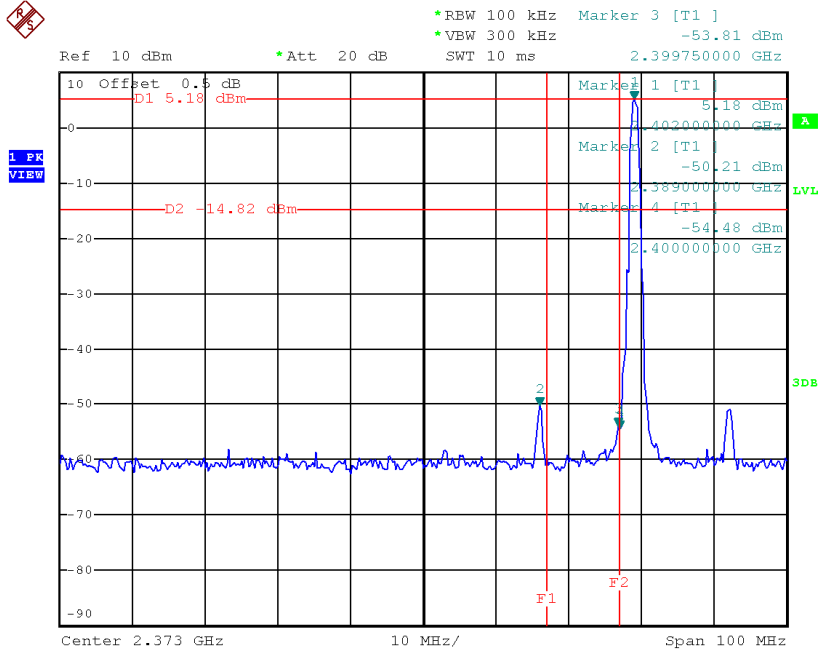

Date: 29.OCT.2014 14:47:46

### CH39 (upper) - 1Mbps

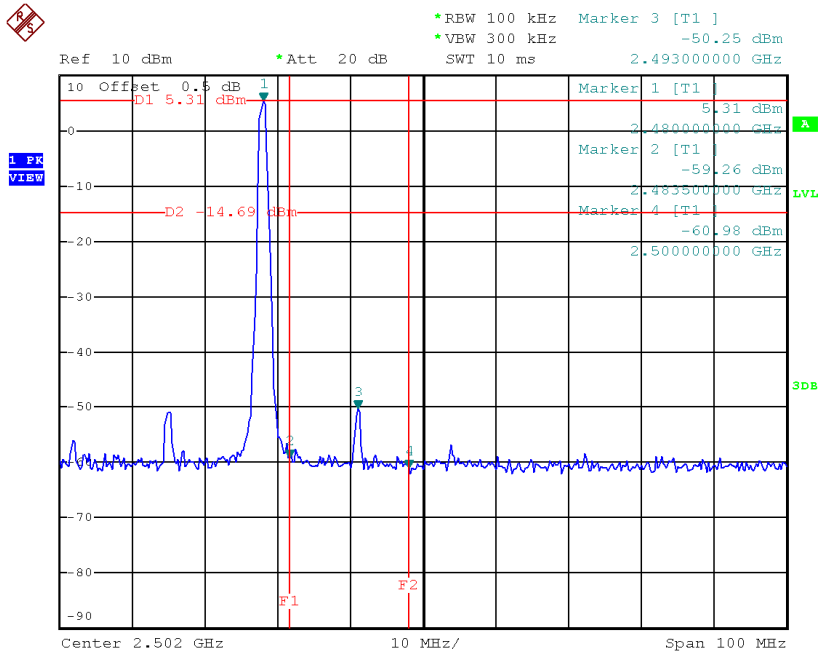

Date: 29.OCT.2014 14:54:56

### CH00 (10 Harmonic of the frequency)

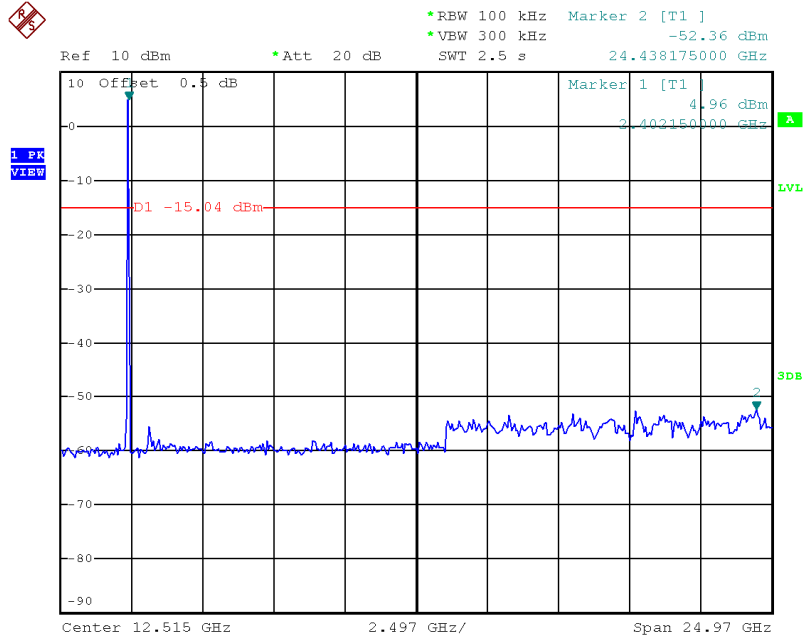

Date: 29.OCT.2014 14:44:31

### CH19 (10 Harmonic of the frequency)

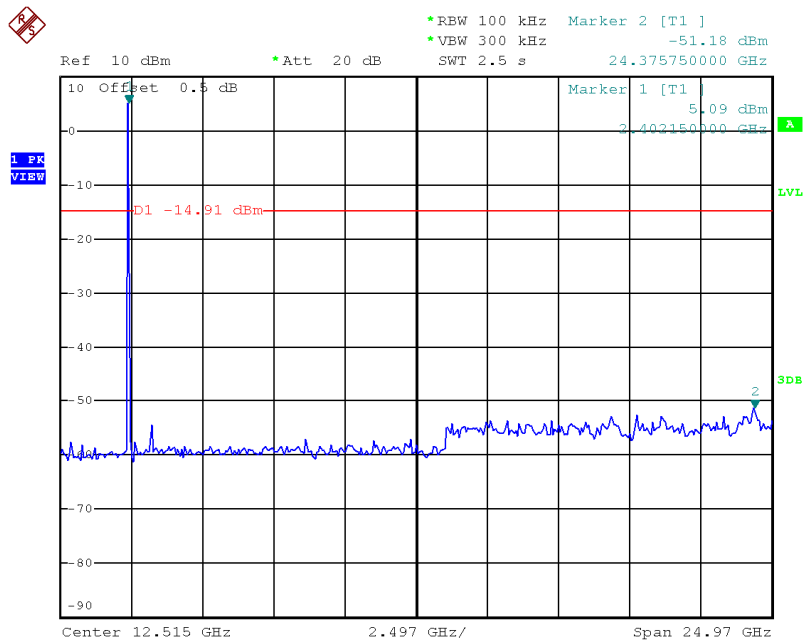

Date: 29.OCT.2014 14:50:46



### CH39 (10 Harmonic of the frequency)

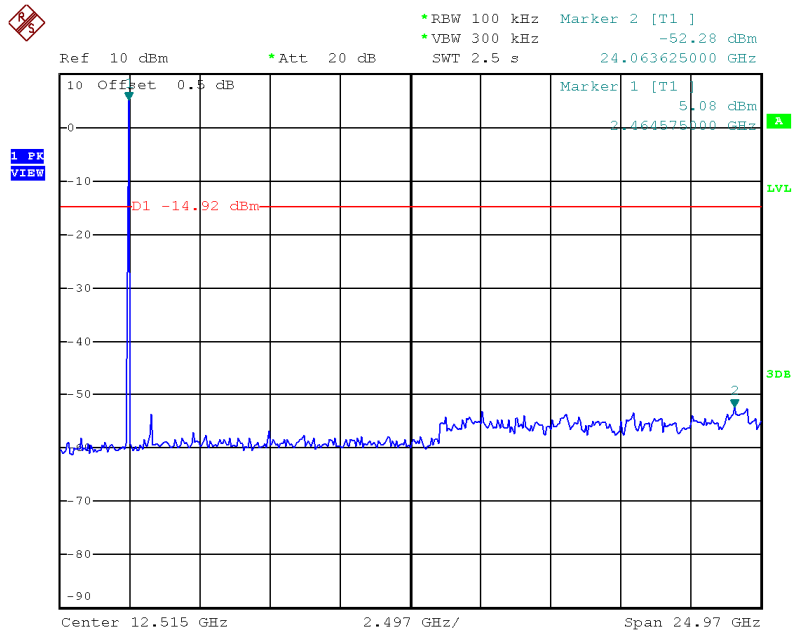

Date: 29.OCT.2014 14:54:17

## **ATTACHMENT H - POWER SPECTRAL DENSITY TEST**

Frequency (MHz)	Power Density (dBm)	Max. Limit (dBm)	Result
2402	-10.60	8	Complies
2440	-9.06	8	Complies
2480	-9.18	8	Complies

### TX CH00

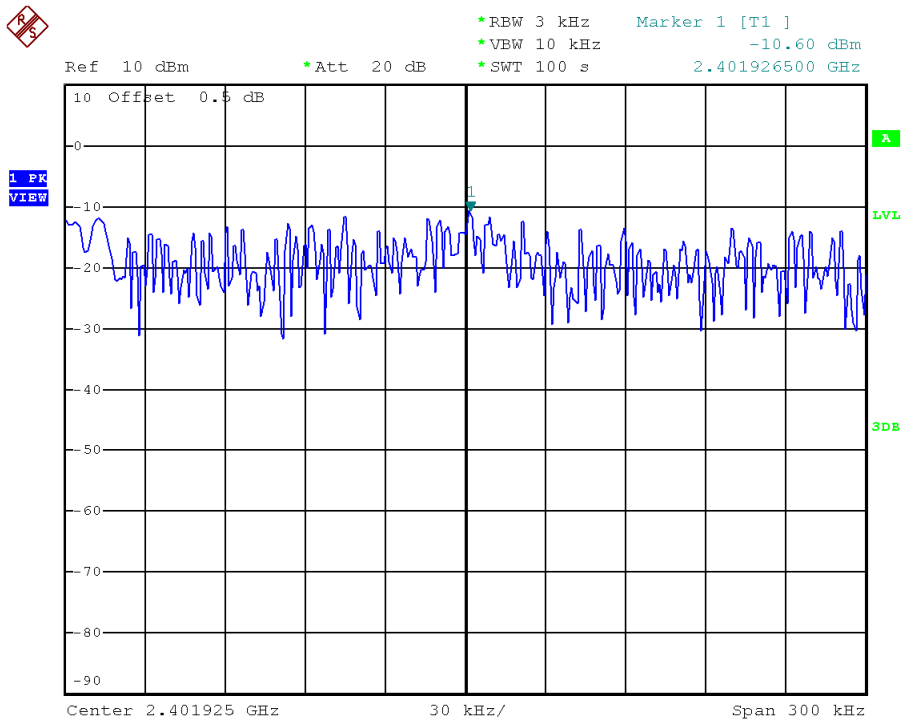

Date: 29.OCT.2014 14:48:20

### TX CH19

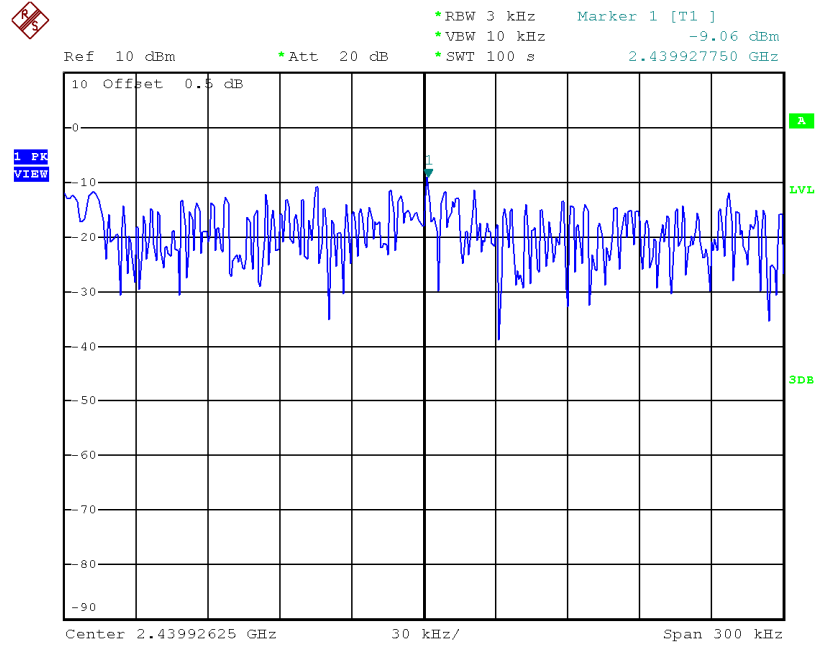

Date: 29.OCT.2014 14:51:46

### TX CH39

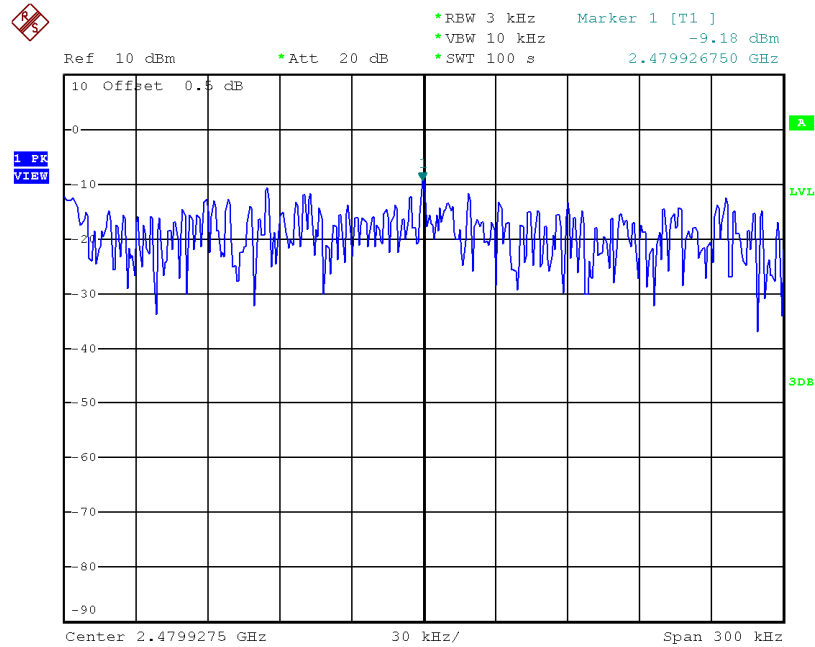

Date: 29.OCT.2014 14:55:25