

RF TEST REPORT



Report No.: FCC_RF_SL15080701-SHT-001_DTS
Supersede Report No.: None

Applicant	:	ShotTracker Inc.
Product Name	:	Net Sensor
Model No.	:	S5N1
Test Standard	:	47 CFR 15.247 RSS-247 Issue 1.0 , May 2015
Test Method	:	ANSI C63.4: 2014 RSS-Gen Issue 4, Nov 2014 558074 D01 DTS Meas Guidance v03r02
FCC ID	:	2AC4B-S5N1
IC ID	:	12327A-S5N1
Dates of test	:	August 19, 2015
Issue Date	:	August 28, 2015
Test Result	:	<input checked="" type="checkbox"/> Pass <input type="checkbox"/> Fail
Equipment complied with the specification [X] Equipment did not comply with the specification []		

This Test Report is Issued Under the Authority of:	
Teody Manansala Test Engineer	Chen Ge Engineer Reviewer

Issued By:
SIEMIC Laboratories
775 Montague Expressway, Milpitas, 95035 CA



775 Montague Expressway, Milpitas, CA 95035, USA • Phone: (+1) 408 526 1188 • Facsimile (+1) 408 526 1088

Visit us at: www.siemic.com; Follow us at:

Laboratory Introduction

SIEMIC, headquartered in the heart of Silicon Valley, with superior facilities in US and Asia, is one of the leading independent testing and certification facilities providing customers with one-stop shop services for Compliance Testing and Global Certifications.



In addition to testing and certification, SIEMIC provides initial design reviews and compliance management throughout a project. Our extensive experience with China, Asia Pacific, North America, European, and International compliance requirements, assures the fastest, most cost effective way to attain regulatory compliance for the global markets.

Accreditations for Conformity Assessment

Country/Region	Accreditation Body	Scope
USA	FCC, A2LA	EMC, RF/Wireless, Telecom
Canada	IC, A2LA, NIST	EMC, RF/Wireless, Telecom
Taiwan	BSMI, NCC, NIST	EMC, RF, Telecom, Safety
Hong Kong	OFTA, NIST	RF/Wireless, Telecom
Australia	NATA, NIST	EMC, RF, Telecom, Safety
Korea	KCC/RRR, NIST	EMI, EMS, RF, Telecom, Safety
Japan	VCCI, JATE, TELEC, RFT	EMI, RF/Wireless, Telecom
Mexico	NOM, COFETEL, Caniety	Safety, EMC, RF/Wireless, Telecom
Europe	A2LA, NIST	EMC, RF, Telecom, Safety
Israel	MOC, NIST	EMC, RF, Telecom, Safety

Accreditations for Product Certifications

Country	Accreditation Body	Scope
USA	FCC TCB, NIST	EMC, RF, Telecom
Canada	IC FCB, NIST	EMC, RF, Telecom
Singapore	iDA, NIST	EMC, RF, Telecom
EU	NB	EMC & R&TTE Directive
Japan	MIC (RCB 208)	RF, Telecom
Hong Kong	OFTA (US002)	RF, Telecom

CONTENTS

1 REPORT REVISION HISTORY4

2 EXECUTIVE SUMMARY5

3 CUSTOMER INFORMATION5

4 TEST SITE INFORMATION5

5 MODIFICATION5

6 EUT INFORMATION6

6.1 EUT Description6

Radio Description6

Spec for BT Radio6

6.2 EUT test modes/configuration Description.....6

6.3 EUT Photos - External7

6.4 EUT Photos – Internal.....8

6.5 EUT Test Setup Photos9

7 SUPPORTING EQUIPMENT/SOFTWARE AND CABLING DESCRIPTION.....10

7.1 Supporting Equipment10

7.2 Cabling Description10

7.3 Test Software Description10

8 TEST SUMMARY11

9 MEASUREMENT UNCERTAINTY12

10 MEASUREMENTS, EXAMINATION AND DERIVED RESULTS13

10.1 Conducted Emissions13

10.2 Peak Output Power (Bluetooth LE)16

10.3 Band Edge (Bluetooth LE)18

10.4 99% Occupied Bandwidth (Bluetooth LE)20

10.5 6dB Bandwidth (Bluetooth LE).....23

10.6 Peak Spectral Density (WLAN & Bluetooth LE)26

10.7 Transmitter Radiated Spurious Emissions Below 1GHz29

10.8 Transmitter Radiated Spurious Emissions > 1GHz & Restricted band & non-restricted band emission31

ANNEX A. TEST INSTRUMENT34

ANNEX B. SIEMIC ACCREDITATION35

1 Report Revision History

Report No.	Report Version	Description	Issue Date
FCC_RF_SL15080701-SHT-001_DTS	None	Original	08/28/2015

2 Executive Summary

The purpose of this test program was to demonstrate compliance of following product

Company: ShotTracker Inc.
Product: Net Sensor
Model: S5N1

against the current Stipulated Standards. The specified model product stated above has demonstrated compliance with the Stipulated Standard listed on 1st page.

3 Customer information

Applicant Name	:	ShotTracker Inc.
Applicant Address	:	9105 Flint, Overland Park, KS 66214
Manufacturer Name	:	ShotTracker Inc.
Manufacturer Address	:	9105 Flint, Overland Park, KS 66214

4 Test site information

Lab performing tests	SIEMIC Laboratories
Lab Address	775 Montague Expressway, Milpitas, CA 95035
FCC Test Site No.	881796
IC Test Site No.	4842D-2
VCCI Test Site No.	A0133

5 Modification

Index	Item	Description	Note
-	-	-	-

6 EUT Information

6.1 EUT Description

Product Name	Net Sensor
Model No.	S5N1
Trade Name	ShotTracker
Serial No.	N/A
Input Power	100-240VAC,0.2A, 50/60Hz
Power Adapter Manu/Model	ARTESYN
Output Power	5 VDC, 1A(Max) 5W(Max)
Battery Manu/ Model	Howell
Battery Power Ratings	3.7V 350mAh
Hardware version Net Sensor	V3
Software version Net Sensor	V1.1
Date of EUT received	08/19/2015
Equipment Class/ Category	DTS
Operating Frequencies	2402-2480MHz
DC Power Cable Type	USB type A to USB mini type A

Radio Description

Spec for BT Radio

Radio Type	Bluetooth (Ver4.0)
Operating Frequency	2402MHz-2480MHz
Modulation	DSSS (LE)
Channel Spacing	2MHz (LE)
Antenna Type	PCB Antenna
Antenna Gain	1dBi (for 2.4GHz)
Antenna Connector Type	On Board

Channel List

Type	Channel No.	Frequency (MHz)	Available (Y/N)
Bluetooth LE	0	2402	Y
	Y
	19	2440	Y
	Y
	39	2480	Y

6.2 EUT test modes/configuration Description

Mode	Note
Bluetooth LE	LE (GFSK)

6.3 EUT Photos - External



EUT – Front View



EUT – Rear View



EUT – Left Side View



EUT – Right Side View



EUT – Top View

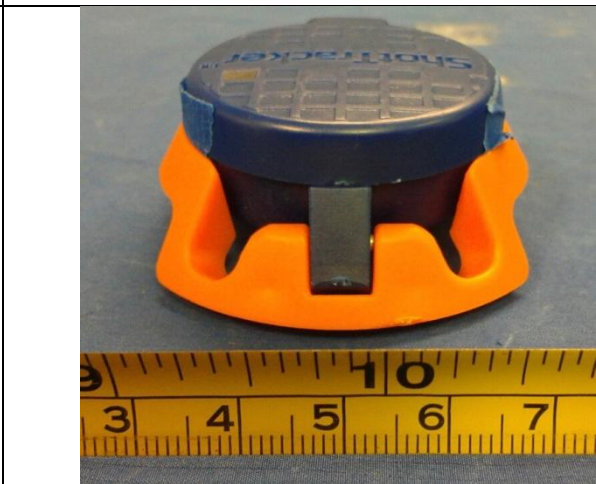

EUT – Bottom View

6.4 EUT Photos – Internal

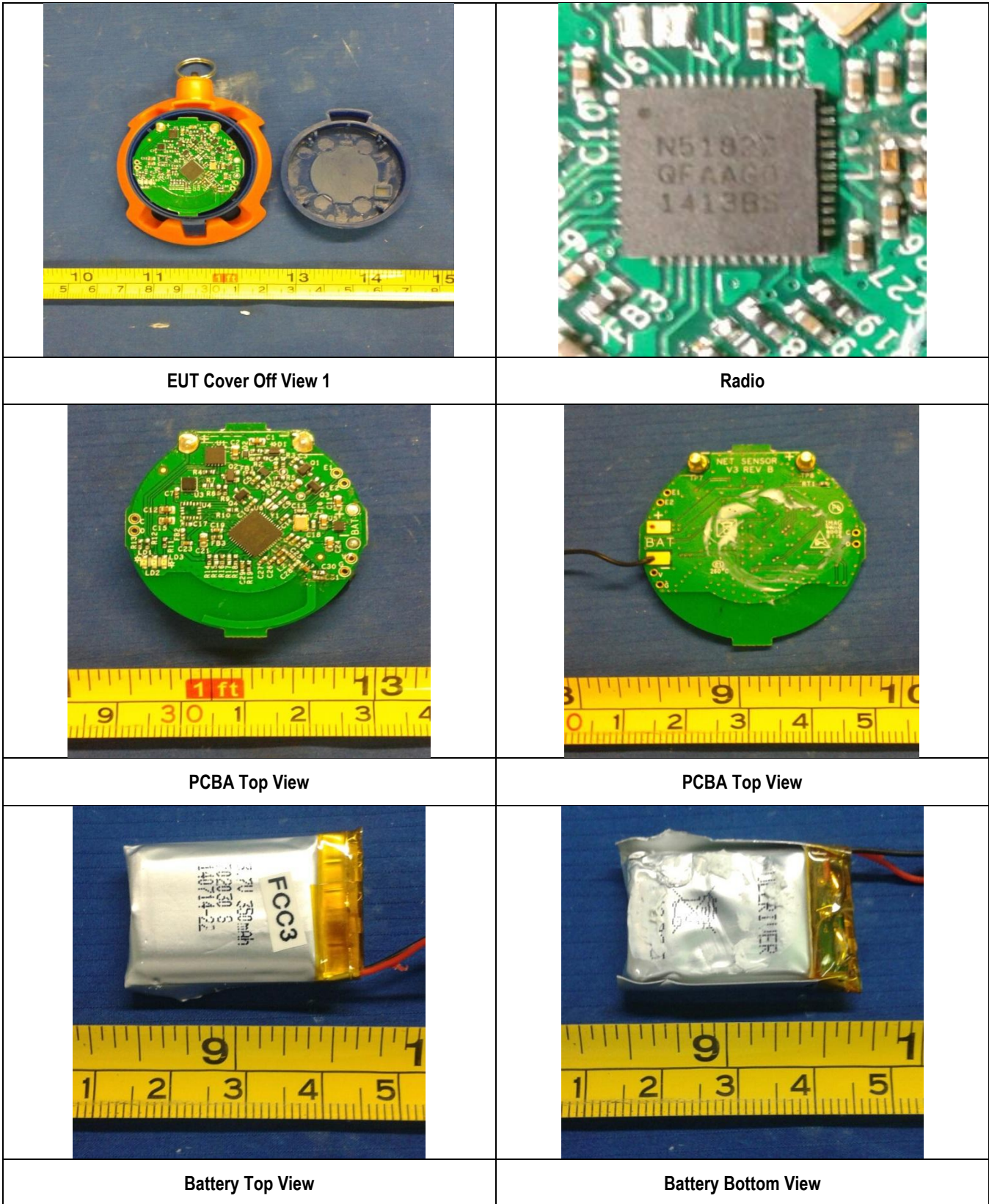

6.5 EUT Test Setup Photos



AC Line Conducted Emissions – Front View



AC Line Conducted Emissions – Rear View

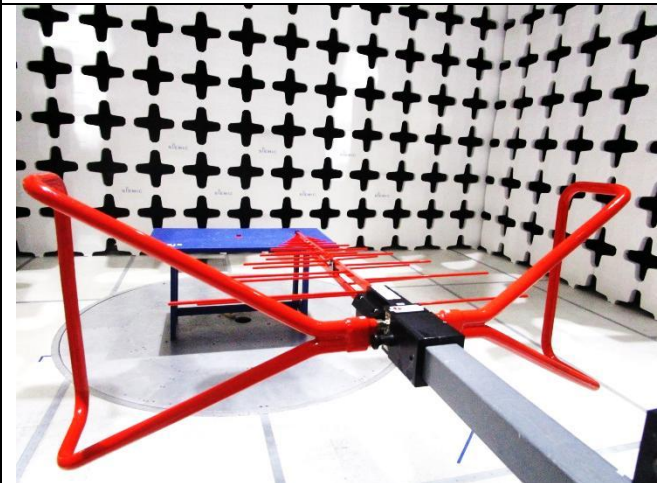

Radiated Emissions (<1GHz) – Front View

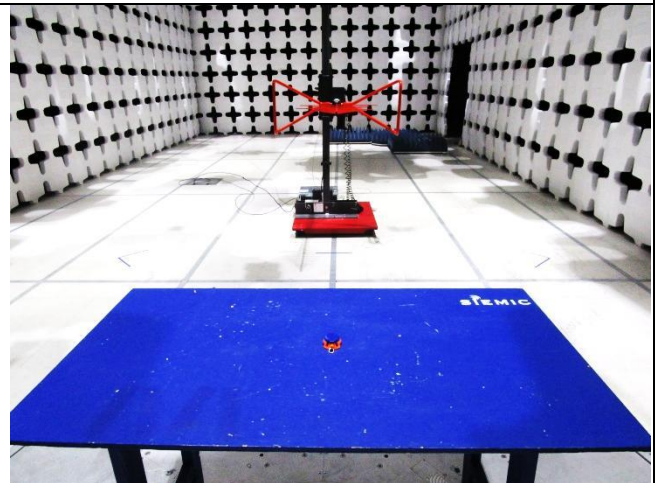

Radiated Emissions (<1GHz) – Rear View



Radiated Emissions (>1GHz) – Front View

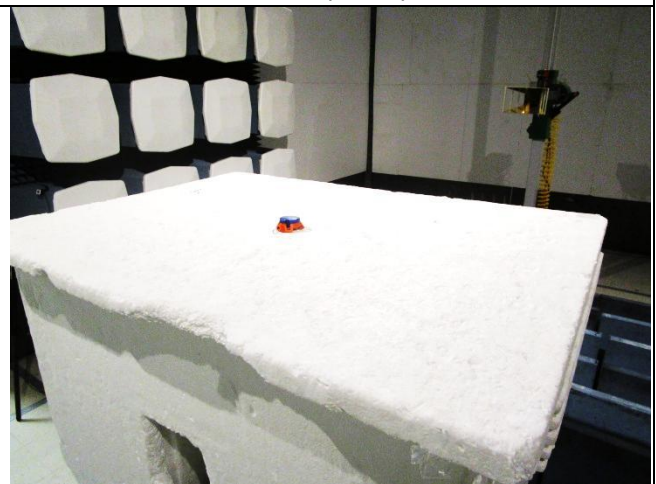

Radiated Emissions (>1GHz) – Rear View

7 Supporting Equipment/Software and cabling Description

7.1 Supporting Equipment

Item	Supporting Equipment Description	Model	Serial Number	Manufacturer	Note
-	-	-	-	-	-

7.2 Cabling Description

Name	Connection Start		Connection Stop		Length / shielding Info		Note
	From	I/O Port	To	I/O Port	Length (m)	Shielding	
-	-	-	-	-	-	-	
-							

7.3 Test Software Description

Test Item	Software	Description
-	-	-

8 Test Summary

Test Item	Test standard		Test Method/Procedure		Pass / Fail
Restricted Band of Operation	FCC	15.205	FCC	ANSI C63.10: 2013 558074 D01 DTS Meas Guidance v03r02	<input checked="" type="checkbox"/> Pass <input type="checkbox"/> N/A
AC Conducted Emissions Voltage	FCC	15.207(a)	FCC	ANSI C63.10: 2013	<input checked="" type="checkbox"/> Pass <input type="checkbox"/> N/A

DTS band Requirement

Test Item	Test standard		Test Method/Procedure		Pass / Fail
Channel Separation	FCC	15.247 (a)(1)	FCC	-	<input type="checkbox"/> Pass <input checked="" type="checkbox"/> N/A
	IC	RSS247(5.1)(3)	IC	-	
99% Occupied Bandwidth	IC	RSS247(5.2)(1)	IC	RSS Gen (6.6)	<input checked="" type="checkbox"/> Pass <input type="checkbox"/> N/A
6db Bandwidth	FCC	15.247(a)(2)	FCC	558074 D01 DTS Meas Guidance v03r02	<input checked="" type="checkbox"/> Pass <input type="checkbox"/> N/A
	IC	RSS247 (5.2)(1)	IC	-	
Number of Hopping Channels	FCC	15.247(a)(1)	FCC	-	<input type="checkbox"/> Pass <input checked="" type="checkbox"/> N/A
	IC	RSS247(5.1)(4)	IC	-	
Band Edge and Radiated Spurious Emissions	FCC	15.247(d)	FCC	ANSI C63.10: 2013 558074 D01 DTS Meas Guidance v03r02	<input checked="" type="checkbox"/> Pass <input type="checkbox"/> N/A
	IC	RSS247(5.5)	IC	-	
Time of Occupancy	FCC	15.247(a)(1)	FCC	-	<input type="checkbox"/> Pass <input checked="" type="checkbox"/> N/A
	IC	RSS247 (5.1)(3)	IC	-	
Output Power	FCC	15.247(b)	FCC	558074 D01 DTS Meas Guidance v03r02	<input checked="" type="checkbox"/> Pass <input type="checkbox"/> N/A
	IC	RS247(5.4)(2)	IC	-	
Receiver Spurious Emissions	IC	RSS Gen (7.1)	IC	RSS Gen (7.1)	<input type="checkbox"/> Pass <input checked="" type="checkbox"/> N/A
Antenna Gain > 6 dBi	FCC	15.247(e)	FCC	-	<input type="checkbox"/> Pass <input checked="" type="checkbox"/> N/A
	IC	RSS247(5.4)(6)(i)	IC	-	
Power Spectral Density	FCC	15.247(e)	FCC	558074 D01 DTS Meas Guidance v03r02	<input checked="" type="checkbox"/> Pass <input type="checkbox"/> N/A
	IC	RSS247(5.2)(2)	IC	-	
Hybrid System Requirement	FCC	15.247(f)	FCC	-	<input type="checkbox"/> Pass <input checked="" type="checkbox"/> N/A
	IC	RSS247(5.3)(2)	IC	-	
Hopping Capability	FCC	15.247(g)	FCC	-	<input type="checkbox"/> Pass <input checked="" type="checkbox"/> N/A
	IC	RSS247(5.1)	IC	-	
Hopping Coordination Requirement	FCC	15.247(h)	FCC	-	<input type="checkbox"/> Pass <input checked="" type="checkbox"/> N/A
	IC	RSS247	IC	-	
RF Exposure requirement	FCC	15.247(i)	FCC	-	<input type="checkbox"/> Pass <input checked="" type="checkbox"/> N/A
	IC	RSS Gen(3.2)	IC	-	

Remark	<ol style="list-style-type: none"> All measurement uncertainties do not take into consideration for all presented test results. The applicant shall ensure frequency stability by showing that an emission is maintained within the band of operation under all normal operating conditions as specified in the user's manual.
--------	--

9 Measurement Uncertainty

Emissions			
Test Item	Frequency Range	Description	Uncertainty
Band Edge and Radiated Spurious Emissions	30MHz – 1GHz	Confidence level of approximately 95% (in the case where distributions are normal), with a coverage factor of 2 (for EUTs < 0.5m X 0.5m X 0.5m)	+5.6dB/-4.5dB
Band Edge and Radiated Spurious Emissions	1GHz – 40GHz	Confidence level of approximately 95% (in the case where distributions are normal), with a coverage factor of 2 (for EUTs < 0.5m X 0.5m X 0.5m)	+4.3dB/-4.1dB

10 Measurements, Examination and Derived Results

10.1 Conducted Emissions

Conducted Emission Limit

Frequency ranges (MHz)	Limit (dBuV)	
	QP	Average
0.15 ~ 0.5	66 – 56	56 – 46
0.5 ~ 5	56	46
5 ~ 30	60	50

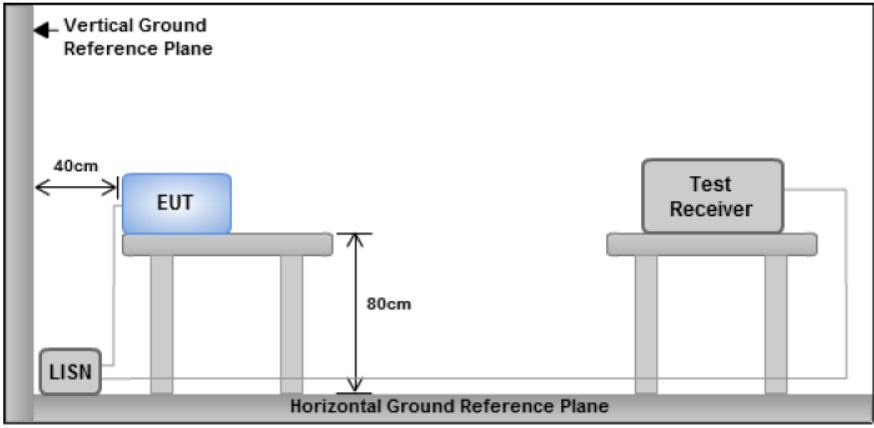
Spec	Item	Requirement	Applicable
47CFR§15.207	a)	For Low-power radio-frequency devices that is designed to be connected to the public utility (AC) power line, the radio frequency voltage that is conducted back onto the AC power line on any frequency or frequencies, within the band 150 kHz to 30 MHz, shall not exceed the limits in the following table, as measured using a 50 μH/50 ohms line impedance stabilization network (LISN). The lower limit applies at the boundary between the frequency ranges.	☒
Test Setup	 <p style="text-align: center;">Note: 1. Support units were connected to second LISN. 2. Both of LISNs (AMN) are 80 cm from EUT and at least 80 cm from other units and other metal planes</p>		
Procedure	<ul style="list-style-type: none"> - The EUT and supporting equipment were set up in accordance with the requirements of the standard on top of a 1.5m x 1m x 0.8m high, non-metallic table, as shown in Annex B. - The power supply for the EUT was fed through a 50Ω/50μH EUT LISN, connected to filtered mains. - The RF OUT of the EUT LISN was connected to the EMI test receiver via a low-loss coaxial cable. - All other supporting equipment was powered separately from another main supply. 		
Remark	EUT tested with AC 110V 60Hz		
Result	☒ Pass ☐ Fail		

Test Data ☒ Yes ☐ N/A

Test Plot ☒ Yes (See below) ☐ N/A

Conducted Emission Test Results (Live)

Test specification:	Conducted Emissions			Result:	<input checked="" type="checkbox"/> Pass <input type="checkbox"/> Fail
Environmental Conditions:	Temp(°C):	22			
	Humidity (%):	40			
	Atmospheric(mbar):	1022			
Mains Power:	110Vac, 60Hz				
Tested by:	Teody Manansala				
Test Date:	08/19/2015				
Remarks	Line				

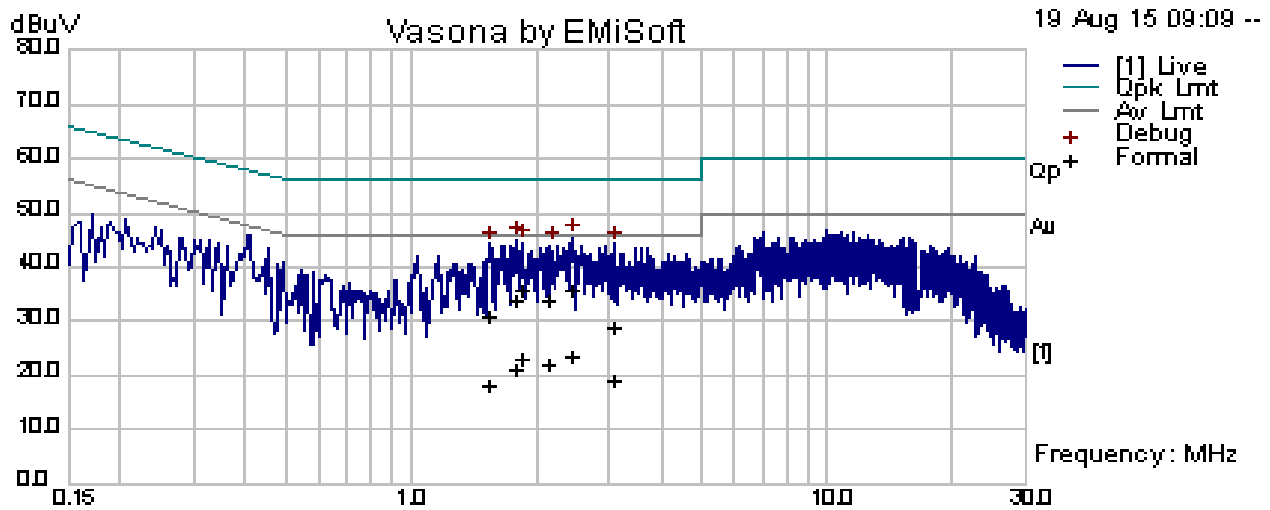

Frequency (MHz)	Raw (dBuV)	Cable Loss (dB)	Factors (dB)	Level (dBuV)	Measurement Type	Line	Limit (dBuV)	Margin (dB)	Pass /Fail
2.45	25.33	10.03	0.55	35.91	Quasi Peak	Line	56.00	-20.09	Pass
1.78	23.21	10.02	0.55	33.79	Quasi Peak	Line	56.00	-22.21	Pass
1.84	25.41	10.02	0.55	35.99	Quasi Peak	Line	56.00	-20.01	Pass
1.54	20.44	10.02	0.56	31.03	Quasi Peak	Line	56.00	-24.97	Pass
3.08	18.41	10.03	0.55	28.99	Quasi Peak	Line	56.00	-27.01	Pass
2.15	23.19	10.02	0.55	33.77	Quasi Peak	Line	56.00	-22.23	Pass
2.45	12.92	10.03	0.55	23.50	Average	Line	46.00	-22.50	Pass
1.78	10.74	10.02	0.55	21.32	Average	Line	46.00	-24.68	Pass
1.84	12.67	10.02	0.55	23.25	Average	Line	46.00	-22.75	Pass
1.54	7.44	10.02	0.56	18.02	Average	Line	46.00	-27.98	Pass
3.08	8.37	10.03	0.55	18.95	Average	Line	46.00	-27.05	Pass
2.15	11.62	10.02	0.55	22.19	Average	Line	46.00	-23.81	Pass

Note: The results above show only the worst case.

Conducted Emission Test Results (Neutral)

Test specification:	Conducted Emissions			Result:	<input checked="" type="checkbox"/> Pass <input type="checkbox"/> Fail
Environmental Conditions:	Temp(°C):	22			
	Humidity (%):	40			
	Atmospheric(mbar):	1022			
Mains Power:	110Vac, 60Hz				
Tested by:	Teody Manansala				
Test Date:	08/19/2015				
Remarks	Neutral				

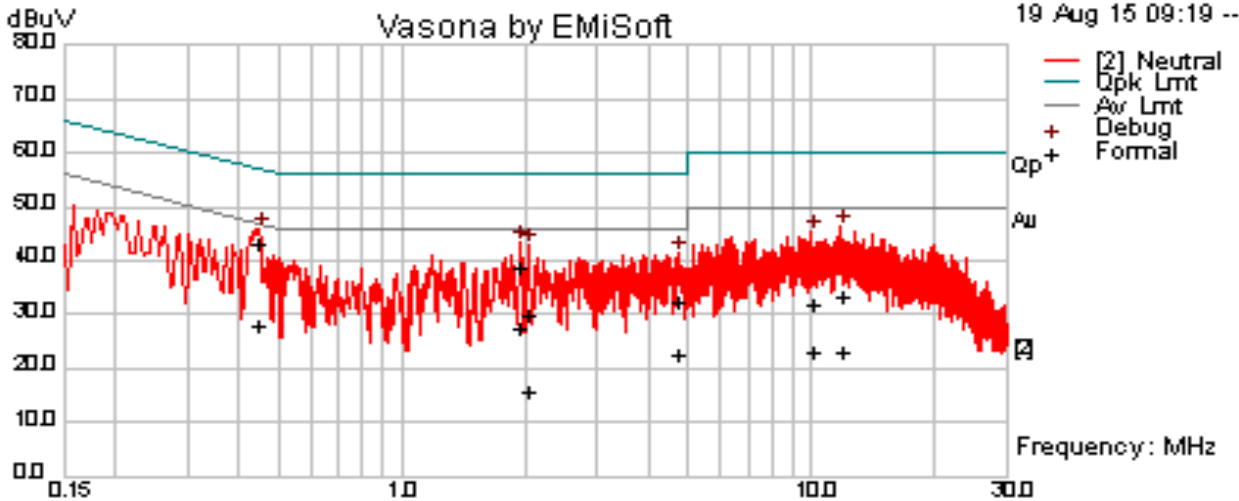

Neutral Line Plot @ 120Vac, 60Hz

Frequency (MHz)	Raw (dBuV)	Cable Loss (dB)	Factors (dB)	Level (dBuV)	Measurement Type	Line	Limit (dBuV)	Margin (dB)	Pass /Fail
0.45	32.28	10.01	0.71	43.00	Quasi Peak	Neutral	56.91	-13.91	Pass
1.94	28.26	10.02	0.55	38.83	Quasi Peak	Neutral	56.00	-17.17	Pass
2.02	19.37	10.02	0.55	29.94	Quasi Peak	Neutral	56.00	-26.06	Pass
11.84	22.56	10.05	0.57	33.18	Quasi Peak	Neutral	60.00	-26.82	Pass
10.01	21.30	10.05	0.55	31.89	Quasi Peak	Neutral	60.00	-28.11	Pass
4.72	21.80	10.04	0.55	32.39	Quasi Peak	Neutral	56.00	-23.61	Pass
0.45	17.11	10.01	0.71	27.83	Average	Neutral	46.91	-19.08	Pass
1.94	16.96	10.02	0.55	27.53	Average	Neutral	46.00	-18.47	Pass
2.02	5.12	10.02	0.55	15.69	Average	Neutral	46.00	-30.31	Pass
11.84	12.59	10.05	0.57	23.21	Average	Neutral	50.00	-26.79	Pass
10.01	12.42	10.05	0.55	23.02	Average	Neutral	50.00	-26.98	Pass
4.72	11.76	10.04	0.55	22.35	Average	Neutral	46.00	-23.65	Pass

Note: The results above show only the worst case.

10.2 Peak Output Power (Bluetooth LE)

Requirement(s):

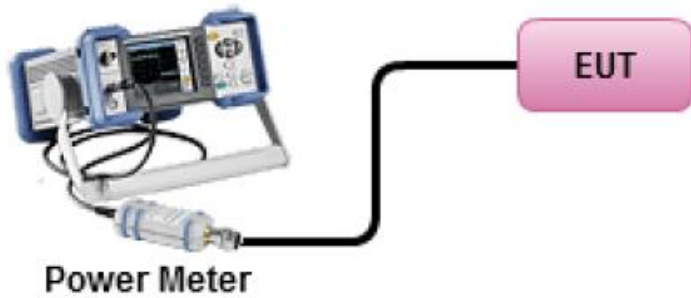
Spec	Item	Requirement	Applicable
§ 15.247	a)	FHSS in 2400-2483.5MHz with ≥ 75 channels: ≤ 1 Watt	<input type="checkbox"/>
	b)	FHSS in 5725-5850MHz: ≤ 1 Watt	<input type="checkbox"/>
	c)	For all other FHSS in the 2400-2483.5MHz band: ≤ 0.125 Watt.	<input type="checkbox"/>
	d)	FHSS in 902-928MHz with ≥ 50 channels: ≤ 1 Watt	<input type="checkbox"/>
	e)	FHSS in 902-928MHz with ≥ 25 & < 50 channels: ≤ 0.25 Watt	<input type="checkbox"/>
	f)	DSSS in 902-928MHz, 2400-2483.5MHz, 5725-5850MHz: ≤ 1 Watt	<input checked="" type="checkbox"/>
Test Setup	 <p>The diagram illustrates a test setup. On the left, a blue and white Power Meter is shown with various cables connected to it. A black cable runs from the Power Meter to a pink rounded rectangle on the right labeled 'EUT' (Equipment Under Test). The text 'Power Meter' is written below the meter.</p>		
Test Procedure	<p><u>Measurement using a Power Meter (PM)</u></p> <p>Measurements may be performed using a wideband gated RF power meter provided that the gate parameters are adjusted such that the power is measured only when the EUT is transmitting at its maximum power control level. Since the measurement is made only during the ON time of the transmitter, no duty cycle correction factor is required.</p> <ul style="list-style-type: none"> - Connect EUT's RF output power to power meter - Set EUT to be continuous transmission mode - Measurement the average output power using power meter and record the result - Repeat above steps for different test channel and other modulation type. 		
Test Date	08/19/2015	Environmental condition	Temperature 23°C Relative Humidity 44% Atmospheric Pressure 1021mbar
Remark			
Result	<input checked="" type="checkbox"/> Pass <input type="checkbox"/> Fail		

Test Data Yes N/A

Test Plot Yes (See below) N/A

Output Power measurement result (Bluetooth)

Type	Test mode	Freq (MHz)	CH	Conducted Power (dBm)	Limit (dBm)	Result
Output power	Bluetooth LE	2402	Low	2.919	30	Pass
Output power	Bluetooth LE	2440	Mid	2.450	30	Pass
Output power	Bluetooth LE	2480	High	1.867	30	Pass

10.3 Band Edge (Bluetooth LE)

Requirement(s):

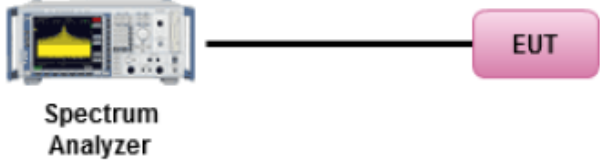
Spec	Item	Requirement	Applicable
§ 15.247	d)	For non-restricted band, In any 100 kHz bandwidth outside the frequency band in which the spread spectrum or digitally modulated intentional radiator is operating, the radio frequency power that is produced by the intentional radiator shall be at least 20 dB or 30dB below that in the 100 kHz bandwidth within the band that contains the highest level of the desired power, determined by the measurement method on output power to be used. Attenuation below the general limits specified in § 15.209 (a) is not required <input type="checkbox"/> 20 dB down <input checked="" type="checkbox"/> 30 dB down	☒
Test Setup			
Test Procedure	558074 D01 DTS Meas Guidance v03r02 <u>Band Edge measurement procedure</u> <ol style="list-style-type: none"> Set the EUT to maximum power setting and enable the EUT transmit continuously. Band edge emissions must be at least 30 dB down from the highest emission level within the authorized band as a measured. The attenuation shall be be 30 dB instead of 20 dB when RMS conducted output power procedure is used. Change modulation and channel bandwidth then repeat step 1 to 2. Measured and record the results in the test report. 		
Test Date	08/19/2015	Environmental condition	Temperature 22°C Relative Humidity 46% Atmospheric Pressure 1020mbar
Remark	-		
Result	<input checked="" type="checkbox"/> Pass <input type="checkbox"/> Fail		

Equipment Setting

TEST	RBW	VBW	SPAN	Detector	SWEEP	Trace	NOTES
Band Edge	100KHz	≥3 x RBW	8 MHz / 10 MHz	Peak	Auto	Peak MAX	-

Test Data Yes N/A

Test Plot Yes (See below) N/A

Band Edge Test Plots (Bluetooth LE)



Band Edge-LE Low



Band Edge-LE High

10.4 99% Occupied Bandwidth (Bluetooth LE)

Requirement(s):

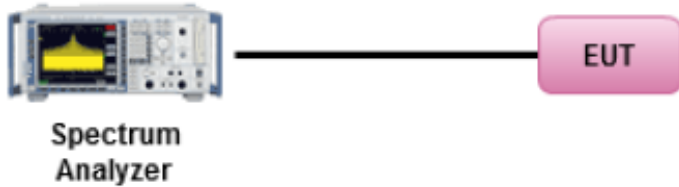
Spec	Requirement	Applicable
RSS247(5.2)(1)	The transmitter shall be operated at its maximum carrier power measured under normal test conditions. The span of the analyzer shall be set to capture all products of the modulation process, including the emission skirts. The resolution bandwidth shall be set to as close to 1% of the selected span as is possible without being below 1%. The video bandwidth shall be set to 3 times the resolution bandwidth. Video averaging is not permitted. Where practical, a sampling detector shall be used given that a peak or peak hold may produce a wider bandwidth than actual. The trace data points are recovered and directly summed in linear terms. The recovered amplitude data points, beginning at the lowest frequency, are placed in a running sum until 0.5% of the total is reached and that frequency recorded. The process is repeated for the highest frequency data points. This frequency is recorded. The span between the two recorded frequencies is the occupied bandwidth	<input checked="" type="checkbox"/>
Test Setup		
Procedure	1. EUT was set for low , mid, high channel with modulated mode and highest RF output power. 2. The spectrum analyzer was connected to the antenna terminal.	
Test Date	08/19/2015	Environmental condition Temperature 23oC Relative Humidity 47% Atmospheric Pressure 1019mbar
Remark	-	
Result	<input checked="" type="checkbox"/> Pass <input type="checkbox"/> Fail	

Test Data Yes (See below) N/A

Test Plot Yes (See below) N/A

99%dB Bandwidth measurement result for Bluetooth LE

Type	Test mode	Freq (MHz)	CH	Result (MHz)	Limit (MHz)	Result
99% BW	BT-LE	2402	Low	1.9590	N/A	N/A
99% BW	BT-LE	2440	Mid	1.8592	N/A	N/A
99% BW	BT-LE	2480	High	1.4394	N/A	N/A

99%dB Bandwidth Test Plot (Bluetooth LE)

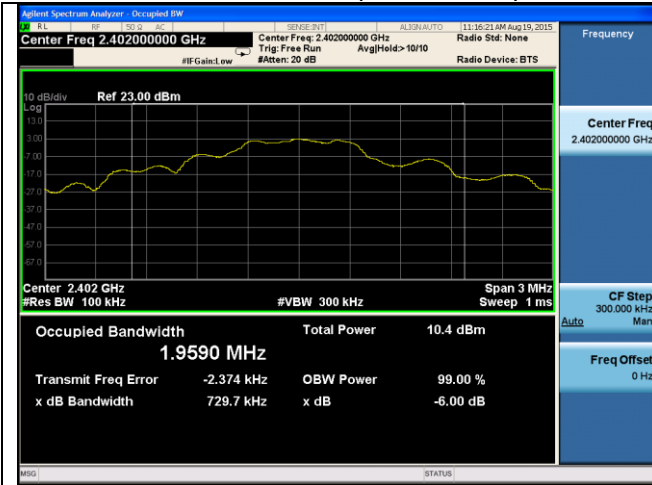

99% BW –Bluetooth LE 2402MHz

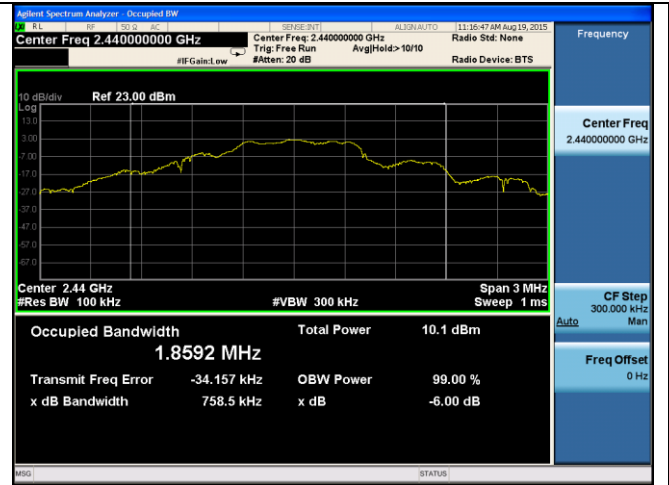

99% BW –Bluetooth LE 2440MHz

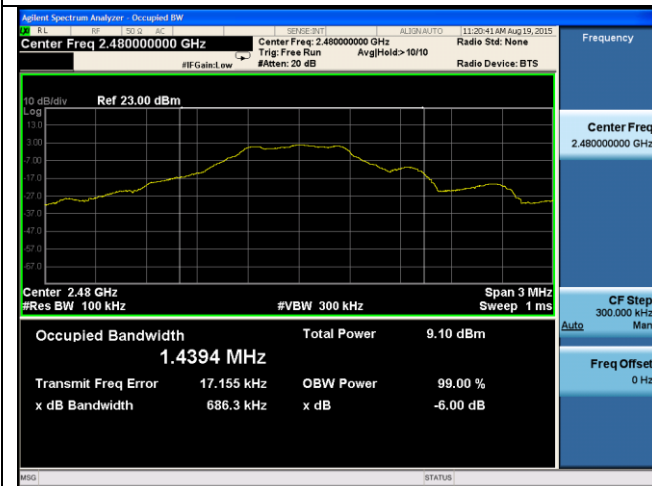

99% BW –Bluetooth LE 2480MHz

10.5 6dB Bandwidth (Bluetooth LE)

Requirement(s):

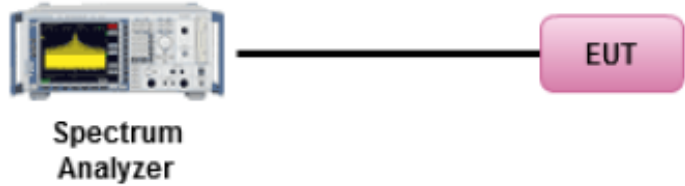
Spec	Item	Requirement	Applicable
§ 15.247 RSS247(5.2)(1)	a)(2)	6dB BW≥500KHz;	<input checked="" type="checkbox"/>
Test Setup	 <p style="text-align: center;">Spectrum Analyzer EUT</p>		
Test Procedure	<p>558074 D01 DTS Meas Guidance v03r02, 8.1 DTS bandwidth</p> <p><u>6dB Emission bandwidth measurement procedure</u></p> <ul style="list-style-type: none"> - Set RBW = 100 kHz. - Set the video bandwidth (VBW) ≥ 3 x RBW. - Detector = Peak. - Trace mode = max hold. - Sweep = auto couple. - Allow the trace to stabilize. - Measure the maximum width of the emission that is constrained by the frequencies associated with the two outermost amplitude points (upper and lower frequencies) that are attenuated by 6 dB relative to the maximum level measured in the fundamental emission. 		
Test Date	08/19/2015	Environmental condition	Temperature 23°C Relative Humidity 42% Atmospheric Pressure 1021mbar
Remark	N/A		
Result	<input checked="" type="checkbox"/> Pass <input type="checkbox"/> Fail		

Equipment Setting

TEST	RBW	VBW	SPAN	Detector	SWEEP	Trace	NOTES
6 dB DTS Bandwidth	100KHz	3 x RBW	>EBW	PK	Auto	Max hold	-

Test Data Yes N/A

Test Plot Yes N/A

6dB Bandwidth measurement result for Bluetooth LE

Type	Test mode	Freq (MHz)	CH	Result (MHz)	Limit (MHz)	Result
6dB BW	Bluetooth LE	2402	Low	0.730	≥0.5	Pass
6dB BW	Bluetooth LE	2440	Mid	0.759	≥0.5	Pass
6dB BW	Bluetooth LE	2480	High	0.686	≥0.5	Pass

6dB Bandwidth Test Plots(Bluetooth LE)

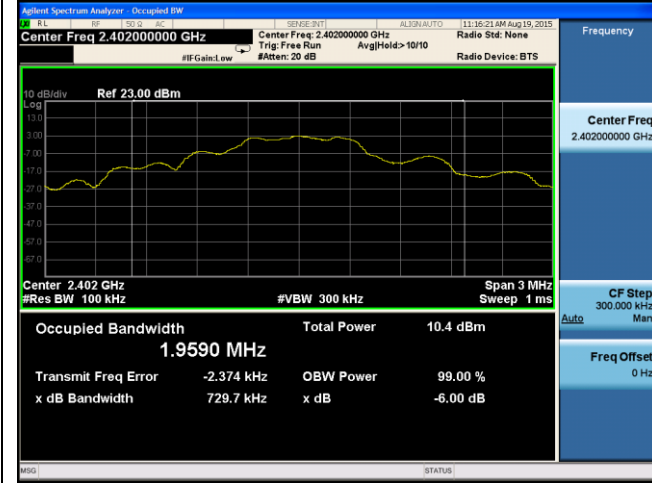

6dB BW –Bluetooth LE 2402MHz

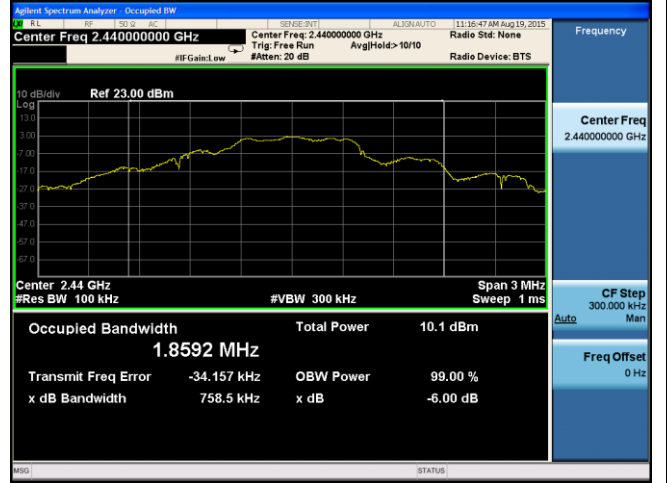

6dB BW –Bluetooth LE 2440MHz

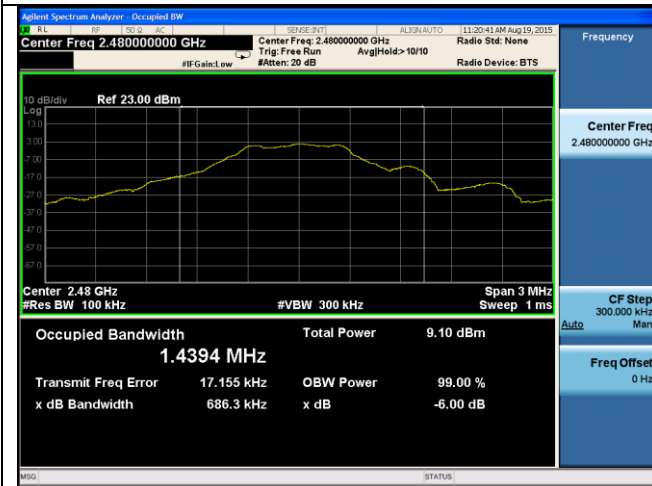

6dB BW –Bluetooth LE 2480MHz

10.6 Peak Spectral Density (WLAN & Bluetooth LE)

Requirement(s):

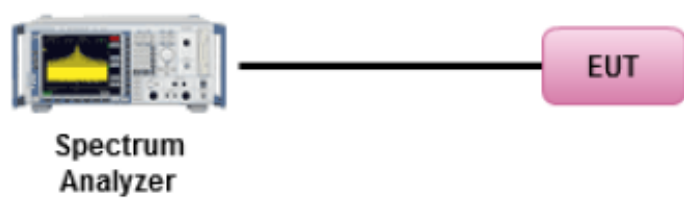
Spec	Item	Requirement	Applicable
§ 15.247(e)	e)	DSSS: $\leq 8\text{dBm}/3\text{KHz}$	<input checked="" type="checkbox"/>
	f)	DSSS in hybrid sys with FH turned off: $\leq 8\text{dBm}/3\text{KHz}$	<input type="checkbox"/>
Test Setup	 <p style="text-align: center;">Spectrum Analyzer EUT</p>		
Test Procedure	<p>558074 D01 DTS Meas Guidance v03r02, 10.3 Method AVGPSD-1</p> <p><u>Peak spectral density measurement procedure</u></p> <ul style="list-style-type: none"> - Set analyzer center frequency to DTS channel center frequency. - Set the span to 1.5 times the DTS bandwidth. - Set the RBW to: $3\text{ kHz} \leq \text{RBW} \leq 100\text{ kHz}$. - Set the VBW $\geq 3 \times \text{RBW}$. - Detector = Peak - Sweep time = auto couple. - Trace mode = Max Hold - Allow trace to fully stabilize. - Use the peak marker function to determine the maximum amplitude level within the RBW. - If measured value exceeds limit, reduce RBW (no less than 3 kHz) and repeat. 		
Test Date	08/19/2015	Environmental condition	Temperature 22°C Relative Humidity 46% Atmospheric Pressure 1020mbar
Remark	-		
Result	<input checked="" type="checkbox"/> Pass <input type="checkbox"/> Fail		

Equipment Setting

TEST	RBW	VBW	SPAN	Detector	SWEEP	Trace	NOTES
PSD	3KHz	$\geq 3x$ RBW	1.5x DTS BW	Peak	Auto	Max Hold	-

Test Data Yes N/A

Test Plot Yes (See below) N/A

PSD measurement result (Bluetooth LE)

Type	Test mode	Freq (MHz)	CH	Conducted PSD (dBm/3KHz)	Limit (dBm/3KHz)	Result
PSD	Bluetooth LE	2402	Low	-10.961	≤8	Pass
PSD	Bluetooth LE	2440	Mid	-11.613	≤8	Pass
PSD	Bluetooth LE	2480	High	-12.732	≤8	Pass

Test Plots (Bluetooth LE)

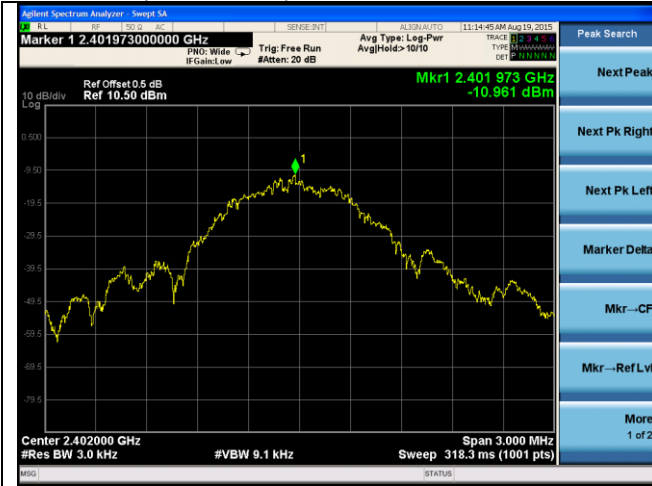

PSD -Bluetooth LE Low



PSD -Bluetooth LE Mid



PSD -Bluetooth LE High

10.7 Transmitter Radiated Spurious Emissions Below 1GHz

Requirement(s):

Spec	Item	Requirement	Applicable										
47CFR§15.247(d), RSS247(5.5)	a)	<p>Except higher limit as specified elsewhere in other section, the emissions from the low-power radio-frequency devices shall not exceed the field strength levels specified in the following table and the level of any unwanted emissions shall not exceed the level of the fundamental emission. The tighter limit applies at the band edges</p> <table border="1"> <thead> <tr> <th>Frequency range (MHz)</th> <th>Field Strength (uV/m)</th> </tr> </thead> <tbody> <tr> <td>30 – 88</td> <td>100</td> </tr> <tr> <td>88 – 216</td> <td>150</td> </tr> <tr> <td>216 960</td> <td>200</td> </tr> <tr> <td>Above 960</td> <td>500</td> </tr> </tbody> </table>	Frequency range (MHz)	Field Strength (uV/m)	30 – 88	100	88 – 216	150	216 960	200	Above 960	500	☒
Frequency range (MHz)	Field Strength (uV/m)												
30 – 88	100												
88 – 216	150												
216 960	200												
Above 960	500												
Test Setup													
Procedure	<ol style="list-style-type: none"> The EUT was switched on and allowed to warm up to its normal operating condition. The test was carried out at the selected frequency points obtained from the EUT characterisation. Maximization of the emissions, was carried out by rotating the EUT, changing the antenna polarization, and adjusting the antenna height in the following manner: <ol style="list-style-type: none"> Vertical or horizontal polarisation (whichever gave the higher emission level over a full rotation of the EUT) was chosen. The EUT was then rotated to the direction that gave the maximum emission. Finally, the antenna height was adjusted to the height that gave the maximum emission. A Quasi-peak measurement was then made for that frequency point. Steps 2 and 3 were repeated for the next frequency point, until all selected frequency points were measured. 												
Remark	The EUT was scanned up to 1GHz. Both horizontal and vertical polarities were investigated. The results show only the worst case.												
Result	☒ Pass ☐ Fail												

Test Data ☒ Yes (See below) ☐ N/A

Test Plot ☒ Yes (See below) ☐ N/A

Radiated Emission Test Results (Below 1GHz)

Test specification:	Radiated Spurious Emissions (30MHz – 1000MHz)		
Environmental Conditions:	Temp(°C):	20	Result: <input checked="" type="checkbox"/> Pass <input type="checkbox"/> Fail
	Humidity (%):	36	
	Atmospheric(mbar):	1021	
Mains Power:	120VAC, 60Hz		
Tested by:	Teody Manansala		
Test Date:	08/19/2015		
Remarks:	Bluetooth LE 2440MHz		

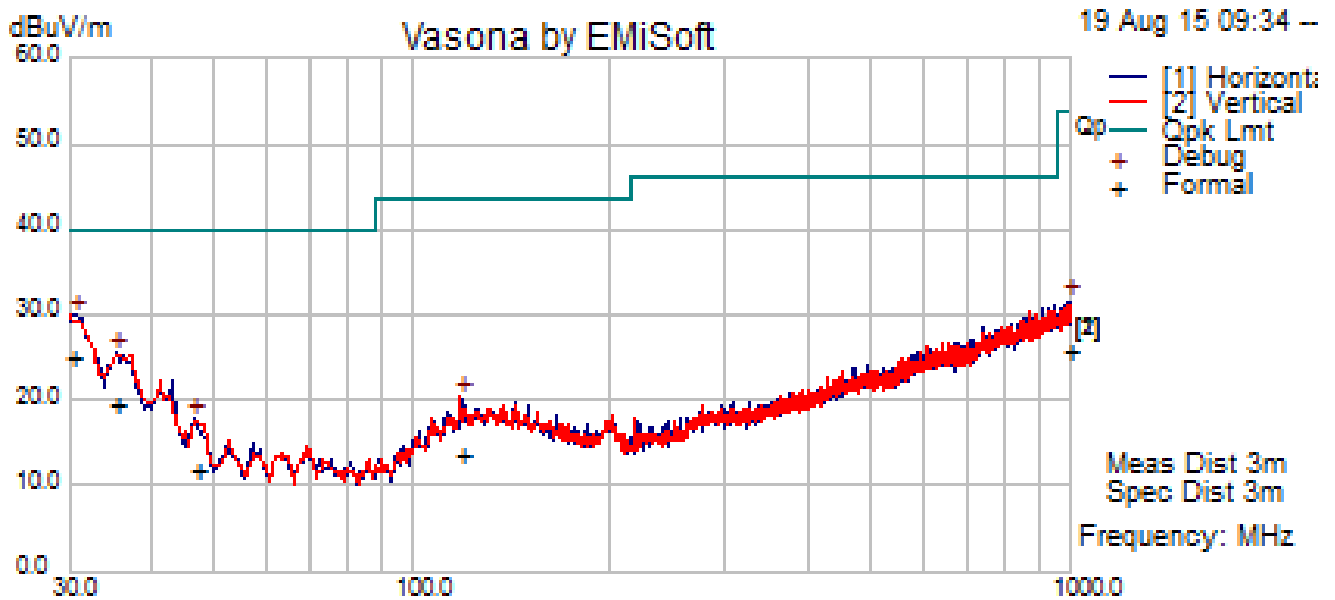

Quasi Max Measurement

Frequency (MHz)	Raw (dBuV)	Cable Loss (dB)	AF (dB)	Level (dBuV/m)	Measurement Type	Pol (V/H)	Hgt (cm)	Azt (Deg)	Limit (dBuV/m)	Margin (dB)	Pass /Fail
30.40	39.76	1.11	-15.75	25.11	Quasi Max	H	276.00	274.00	40.00	-14.89	Pass
35.37	38.11	1.19	-19.76	19.54	Quasi Max	H	128.00	61.00	40.00	-20.46	Pass
46.87	38.10	1.38	-27.67	11.81	Quasi Max	V	234.00	65.00	40.00	-28.19	Pass
997.20	34.82	6.34	-15.54	25.61	Quasi Max	H	336.00	175.00	53.98	-28.37	Pass
118.57	36.76	2.10	-25.21	13.66	Quasi Max	V	100.00	324.00	43.52	-29.86	Pass

10.8 Transmitter Radiated Spurious Emissions > 1GHz & Restricted band & non-restricted band emission

Requirement(s):

Spec	Item	Requirement	Applicable
47CFR§15.247(d), RSS247(5.5)	a)	For non-restricted band, In any 100 kHz bandwidth outside the frequency band in which the spread spectrum or digitally modulated intentional radiator is operating, the radio frequency power that is produced by the intentional radiator shall be at least 20 dB or 30dB below that in the 100 kHz bandwidth within the band that contains the highest level of the desired power, determined by the measurement method on output power to be used. Attenuation below the general limits specified in § 15.209(a) is not required <input type="checkbox"/> 20 dB down <input checked="" type="checkbox"/> 30 dB down	<input checked="" type="checkbox"/>
	b)	or restricted band, emission must also comply with the radiated emission limits specified in 15.209	<input checked="" type="checkbox"/>
Test Setup			
Procedure	<ol style="list-style-type: none"> The EUT was switched on and allowed to warm up to its normal operating condition. The test was carried out at the selected frequency points obtained from the EUT characterisation. Maximization of the emissions, was carried out by rotating the EUT, changing the antenna polarization, and adjusting the antenna height in the following manner: <ol style="list-style-type: none"> Vertical or horizontal polarisation (whichever gave the higher emission level over a full rotation of the EUT) was chosen. The EUT was then rotated to the direction that gave the maximum emission. Finally, the antenna height was adjusted to the height that gave the maximum emission. An average measurement was then made for that frequency point. Steps 2 and 3 were repeated for the next frequency point, until all selected frequency points were measured. 		
Remark	The EUT was scanned up to 25GHz. Both horizontal and vertical polarities were investigated. The results show only the worst case.		
Result	<input checked="" type="checkbox"/> Pass <input type="checkbox"/> Fail		

Equipment Setting

TEST	RBW	VBW	SPAN	Detector	SWEEP	Trace	NOTES
Radiated Spurious Emission	1MHz	3MHz	1GHz - 25 GHz	Peak	Auto	Max hold	PK Measurement
Radiated Spurious Emission	1MHz	10Hz	1GHz - 25 GHz	Peak	Auto	Max hold	Ave Measurement

Test Data Yes (See below) N/A

Test Plot Yes (See below) N/A

Test specification:	Radiated Spurious Emissions (above 1GHz)			
Environmental Conditions:	Temp(°C):	20	Result:	<input checked="" type="checkbox"/> Pass <input type="checkbox"/> Fail
	Humidity (%):	36		
	Atmospheric(mbar):	1021		
Mains Power:	120VA, 60Hz			
Tested by:	Teody Manansala			
Test Date:	08/19/2015			
Remarks:	Bluetooth LE			

Bluetooth LE – 2402MHz

Frequency (MHz)	Raw (dBuV)	Cable Loss (dB)	AF (dB)	Level (dBuV/m)	Measurement Type	Pol (V/H)	Hgt (cm)	Azt (Deg)	Limit (dBuV/m)	Margin (dB)	Pass /Fail
7216.86	42.73	8.42	7.90	59.05	Peak Max	V	297.00	221.00	74.00	-14.95	Pass
4084.85	40.53	5.90	11.85	58.29	Peak Max	H	200.00	81.00	74.00	-15.71	Pass
1001.66	45.56	2.44	9.68	57.68	Peak Max	V	288.00	291.00	74.00	-16.32	Pass
2091.21	44.23	3.68	11.19	59.10	Peak Max	H	294.00	205.00	74.00	-14.90	Pass
7216.86	29.25	8.42	7.90	45.56	Average Max	V	297.00	221.00	54.00	-8.44	Pass
4084.85	27.31	5.90	11.85	45.07	Average Max	H	200.00	81.00	54.00	-8.93	Pass
1001.66	32.77	2.44	9.68	44.89	Average Max	V	288.00	291.00	54.00	-9.11	Pass
2091.21	30.58	3.68	11.19	45.45	Average Max	H	294.00	205.00	54.00	-8.55	Pass

Bluetooth LE – 2440MHz

Frequency (MHz)	Raw (dBuV)	Cable Loss (dB)	AF (dB)	Level (dBuV/m)	Measurement Type	Pol (V/H)	Hgt (cm)	Azt (Deg)	Limit (dBuV/m)	Margin (dB)	Pass /Fail
7317.65	42.03	8.50	7.91	58.44	Peak Max	V	127.00	210.00	74.00	-15.56	Pass
1034.22	44.75	2.46	9.62	56.83	Peak Max	H	157.00	328.00	74.00	-17.17	Pass
2074.28	43.69	3.62	11.24	58.55	Peak Max	H	151.00	219.00	74.00	-15.45	Pass
3947.11	39.51	5.80	12.04	57.35	Peak Max	V	118.00	164.00	74.00	-16.65	Pass
7317.65	28.92	8.50	7.91	45.33	Average Max	V	127.00	210.00	54.00	-8.67	Pass
1034.22	32.01	2.46	9.62	44.10	Average Max	H	157.00	328.00	54.00	-9.90	Pass
2074.28	30.40	3.62	11.24	45.26	Average Max	H	151.00	219.00	54.00	-8.74	Pass
3947.11	26.80	5.80	12.04	44.64	Average Max	V	118.00	164.00	54.00	-9.36	Pass

Bluetooth LE – 2480MHz

Frequency (MHz)	Raw (dBuV)	Cable Loss (dB)	AF (dB)	Level (dBuV/m)	Measurement Type	Pol (V/H)	Hgt (cm)	Azt (Deg)	Limit (dBuV/m)	Margin (dB)	Pass /Fail
1734.10	39.63	3.02	9.38	52.03	Peak Max	V	146.00	250.00	74.00	-21.97	Pass
1000.22	44.61	2.44	9.68	56.72	Peak Max	H	158.00	306.00	74.00	-17.28	Pass
4033.96	39.97	5.86	12.08	57.91	Peak Max	V	143.00	129.00	74.00	-16.09	Pass
1953.83	43.59	3.28	11.11	57.98	Peak Max	H	206.00	192.00	74.00	-16.02	Pass
1734.10	27.05	3.02	9.38	39.45	Average Max	V	146.00	250.00	54.00	-14.55	Pass
1000.22	32.37	2.44	9.68	44.49	Average Max	H	158.00	306.00	54.00	-9.51	Pass
4033.96	26.96	5.86	12.08	44.90	Average Max	V	143.00	129.00	54.00	-9.10	Pass
1953.83	29.77	3.28	11.11	44.16	Average Max	H	206.00	192.00	54.00	-9.84	Pass

Restricted Band Test plot (Bluetooth BDR/EDR)

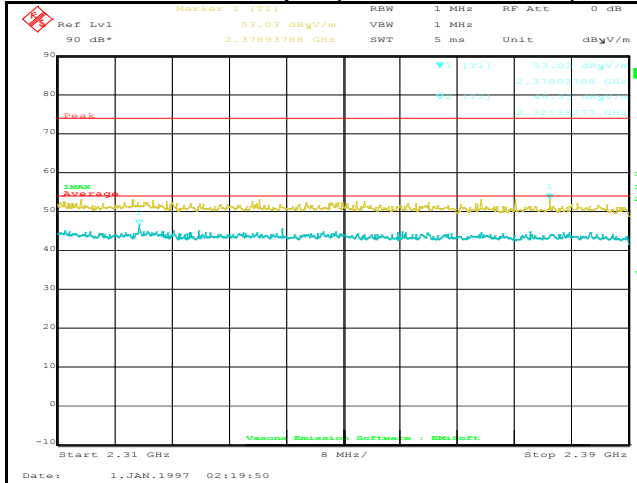

Restricted Band Low BDR

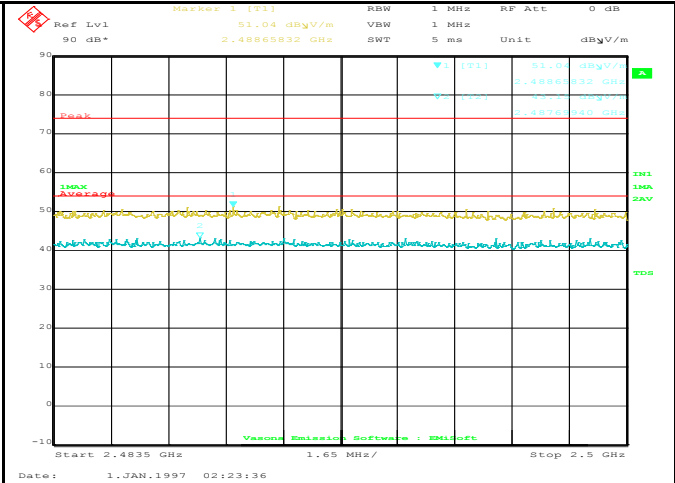























Restricted Band High BDR

Annex A. TEST INSTRUMENT

Instrument	Model	Serial #	Cal Date	Cal Cycle	Cal Due	In use
Conducted Emissions						
EMI Test Receiver (9 kHz – 30 MHz)	ESHS10	830223/009	06/24/2015	1 Year	06/24/2016	<input checked="" type="checkbox"/>
Signal Analyzer	FSIQ7	825555/013	05/28/2015	1 Year	05/28/2016	<input checked="" type="checkbox"/>
V-LISN (150 kHz – 30 MHz)	NNLK 8129	8129-190	08/24/2015	1 Year	08/24/2016	<input checked="" type="checkbox"/>
LISN (9 kHz – 30 MHz)	MN2050B	1018	07/31/2015	1 Year	07/31/2016	<input checked="" type="checkbox"/>
Radiated Emissions						
R & S Receiver	ESL6	100178	05/27/2015	1 Year	05/27/2016	<input checked="" type="checkbox"/>
R & S Receiver	ESIB 40	100179	05/24/2015	1 Year	05/24/2016	<input checked="" type="checkbox"/>
Bi-Log antenna (30MHz~2GHz)	JB1	A030702	08/12/2014	1 Year	08/20/2016	<input checked="" type="checkbox"/>
Horn Antenna (1-26.5GHz)	3115	10SL0059	08/11/2015	1 Year	08/11/2016	<input checked="" type="checkbox"/>
Horn Antenna (18-40 GHz)	AH-840	101013	08/11/2014	1 Year	02/19/2016	<input type="checkbox"/>
Pre-Amplifier (100KHz-7GHz)	LPA-6-30	11140711	02/19/2015	1 Year	02/19/2016	<input checked="" type="checkbox"/>
Microwave Preamplifier (18-40 GHz)	PA-840	181251	02/19/2015	1 Year	02/19/2016	<input checked="" type="checkbox"/>
R & S Receiver	ESL6	100178	05/27/2015	1 Year	05/27/2016	<input checked="" type="checkbox"/>
R & S Receiver	ESIB 40	100179	05/24/2015	1 Year	05/24/2016	<input checked="" type="checkbox"/>
RF Conducted Measurement						
Spectrum Analyzer	N9020A	MY50210206	01/26/2015	1 Year	01/26/2016	<input checked="" type="checkbox"/>
Power Meter	7002-006	10SL0189	4/30/2015	1 Year	4/30/2016	<input type="checkbox"/>

Annex B. SIEMIC Accreditation

Accreditations	Document	Scope / Remark
ISO 17025 (A2LA)		Please see the documents for the detailed scope
ISO Guide 65 (A2LA)		Please see the documents for the detailed scope
TCB Designation		A1, A2, A3, A4, B1, B2, B3, B4, C
FCC DoC Accreditation		FCC Declaration of Conformity Accreditation
FCC Site Registration		3 meter site
FCC Site Registration		10 meter site
IC Site Registration		3 meter site
IC Site Registration		10 meter site
EU NB		Radio & Telecommunications Terminal Equipment: EN45001 – EN ISO/IEC 17025
		Electromagnetic Compatibility: EN45001 – EN ISO/IEC 17025
Singapore iDA CB(Certification Body)		Phase I, Phase II
Vietnam MIC CAB Accreditation		Please see the document for the detailed scope
Hong Kong OFCA		(Phase II) OFCA Foreign Certification Body for Radio and Telecom
		(Phase I) Conformity Assessment Body for Radio and Telecom
Industry Canada CAB		Radio: Scope A – All Radio Standard Specification in Category I
		Telecom: CS-03 Part I, II, V, VI, VII, VIII

Japan Recognized Certification Body Designation		<p>Radio: A1. Terminal equipment for purpose of calling</p> <p>Telecom: B1. Specified radio equipment specified in Article 38-2, Paragraph 1, Item 1 of the Radio Law</p>
Korea CAB Accreditation		<p>EMI: KCC Notice 2008-39, RRL Notice 2008-3: CA Procedures for EMI KN22: Test Method for EMI</p> <p>EMS: KCC Notice 2008-38, RRL Notice 2008-4: CA Procedures for EMS KN24, KN61000-4-2, -4-3, -4-4, -4-5, -4-6, -4-8, -4-11: Test Method for EMS</p> <p>Radio: RRL Notice 2008-26, RRL Notice 2008-2, RRL Notice 2008-10, RRL Notice 2007-49, RRL Notice 2007-20, RRL Notice 2007-21, RRL Notice 2007-80, RRL Notice 2004-68</p> <p>Telecom: President Notice 20664, RRL Notice 2007-30, RRL Notice 2008-7 with attachments 1, 3, 5, 6; President Notice 20664, RRL Notice 2008-7 with attachment 4</p>
Taiwan NCC CAB Recognition		LP0002, PSTN01, ADSL01, ID0002, IS6100, CNS14336, PLMN07, PLMN01, PLMN08
Taiwan BSMI CAB Recognition		CNS 13438
Japan VCCI		<p>R-3083: Radiation 3 meter site</p> <p>C-3421: Main Ports Conducted Interference Measurement</p> <p>T-1597: Telecommunication Ports Conducted Interference Measurement</p>
Australia CAB Recognition		<p>EMC: AS/NZS CISPR 11, AS/NZS CISPR 14.1, AS/NZS CISPR22, AS/NZS 61000.6.3, AS/NZS 61000.6.4</p> <p>Radio communications: AS/NZS 4281, AS/NZS 4268, AS/NZS 4280.1, AS/NZS 4280.2, AS/NZS 4295, AS/NZS 4582, AS/NZS 4583, AS/NZS 4769.1, AS/NZS 4769.2, AS/NZS 4770, AS/NZS 4771</p> <p>Telecommunications: AS/ACIF S002:05, AS/ACIF S003:06, AS/ACIF S004:06 AS/ACIF S006:01, AS/ACIF S016:01, AS/ACIF S031:01, AS/ACIF S038:01, AS/ACIF S040:01, AS/ACIF S041:05, AS/ACIF S043.2:06, AS/ACIF S60950.1</p>
Australia NATA Recognition		AS/ACIF S002, AS/ACIF S003, AS/ACIF S004, AS/ACIF S006, AS/ACIF S016, AS/ACIF S031, AS/ACIF S038, AS/ACIF S040, AS/ACIF S041, AS/ACIF S043.2