



FCC RADIO TEST REPORT

FCC ID: 2AC48-VC-16

Product : Remote control

Trade Mark : VISICO

Model Name : VC-16

Serial Model : N/A

Report No. : SRS171109806

Prepared for

YUYAO VISTAR ELECTRONIC SCIENCE & TECHNOLOGY CO.,LTD.
NO.206 BEIXING ROAD OF WEST CITY INDUSTRIAL DEVELOPMENT
ZONE, YUYAO CITY, ZHEJIANG, CHINA

Prepared by

NTEK Testing Technology Co., Ltd.
1/F, Building E, Fenda Science Park, Sanwei Community, Xixiang Street
Bao'an District, Shenzhen 518126 P.R. China
Tel.: +86-755-6115 6588 Fax.: +86-755-6115 6599
Website: <http://www.ntek.org.cn>

TEST RESULT CERTIFICATION

Applicant's name : YUYAO VISTAR ELECTRONIC SCIENCE & TECHNOLOGY CO.,LTD.
Address : NO.206 BEIXING ROAD OF WEST CITY INDUSTRIAL DEVELOPMENT ZONE, YUYAO CITY, ZHEJIANG, CHINA
Manufacturer's Name : YUYAO VISTAR ELECTRONIC SCIENCE & TECHNOLOGY CO.,LTD.
Address : NO.206 BEIXING ROAD OF WEST CITY INDUSTRIAL DEVELOPMENT ZONE, YUYAO CITY, ZHEJIANG, CHINA

Product description

Product name : Remote control
Model and/or type reference : VC-16
Serial Model : N/A
Rating(s) : DC 2*1.5Vfrom AA battery

Standards : FCC Part15.249

Test procedure ANSI C63.10-2013

This device described above has been tested by NTEK, and the test results show that the equipment under test (EUT) is in compliance with the FCC requirements. And it is applicable only to the tested sample identified in the report.

This report shall not be reproduced except in full, without the written approval of NTEK, this document may be altered or revised by NTEK, personnel only, and shall be noted in the revision of the document.

Date of Test :
Date (s) of performance of tests : 21 Oct. 2017 ~ 08 Nov. 2017
Date of Issue : 08 Nov. 2017
Test Result : **Pass**

Testing Engineer : Eileen Liu.
 (Eileen Liu)

Technical Manager : Jason chen
 (Jason Chen)

Authorized Signatory : Sam. chen
 (Sam Chen)

Table of Contents	Page
1 . SUMMARY OF TEST RESULTS	4
1.1 TEST FACILITY	5
1.2 MEASUREMENT UNCERTAINTY	5
2 . GENERAL INFORMATION	6
2.1 GENERAL DESCRIPTION OF EUT	6
2.2 DESCRIPTION OF TEST MODES	7
2.3 BLOCK DIGRAM SHOWING THE CONFIGURATION OF SYSTEM TESTED	8
2.4 DESCRIPTION OF SUPPORT UNITS(CONDUCTED MODE)	9
3 . ANTENNA REQUIREMENT	11
3.1 STANDARD REQUIREMENT	11
3.2 EUT ANTENNA	11
3.3 CONDUCTED EMISSION MEASUREMENT	12
3.3.1 POWER LINE CONDUCTED EMISSION LIMITS	12
3.3.2 TEST PROCEDURE	13
3.3.3 DEVIATION FROM TEST STANDARD	13
3.3.4 TEST SETUP	13
3.3.5 TEST RESULTS	13
3.4 RADIATED EMISSION MEASUREMENT	14
3.4.1 RADIATED EMISSION LIMITS	14
3.4.2 TEST PROCEDURE	15
3.4.3 DEVIATION FROM TEST STANDARD	15
3.4.4 TEST SETUP	16
3.4.5 TEST RESULTS (BLOW 30MHZ)	18
3.4.6 TEST RESULTS (BETWEEN 30 – 1000 MHZ)	19
3.4.7 TEST RESULTS (ABOVE 1000 MHZ)	21
3.4.8 TEST RESULTS (RESTRICTED BANDS REQUIREMENTS)	24
4 . BANDWIDTH TEST	25
4.1 TEST PROCEDURE	25
4.2 DEVIATION FROM STANDARD	25
4.3 TEST SETUP	25
4.4 TEST RESULTS	26
5 . EUT TEST PHOTO	28
APPENDIX-PHOTOGRAPHS OF EUT CONSTRUCTIONAL DETAILS	

1. SUMMARY OF TEST RESULTS

Test procedures according to the technical standards:

FCC Part15, Subpart C (15.249)			
Standard Section	Test Item	Judgment	Remark
15.207	Conducted Emission	N/A	
15.203	Antenna Requirement	Pass	
15.249	Radiated Spurious Emission	Pass	
15.205	Band Edge Emission	Pass	
15.249	Occupied Bandwidth	Pass	

1.1 TEST FACILITY

NTEK Testing Technology Co., Ltd

Add. : 1/F, Building E, Fenda Science Park, Sanwei Community, Xixiang Street, Bao'an District, Shenzhen 518126 P.R. China.

FCC FRN Registration No.: 463705; IC Registration No.:9270A-1

CNAS Registration No.:L5516

1.2 MEASUREMENT UNCERTAINTY

The reported uncertainty of measurement $y \pm U$, where expanded uncertainty U is based on a standard uncertainty multiplied by a coverage factor of $k=2$, providing a level of confidence of approximately 95 %.

No.	Item	Uncertainty
1	Conducted Emission Test	$\pm 1.38\text{dB}$
2	RF power,conducted	$\pm 0.16\text{dB}$
3	Spurious emissions,conducted	$\pm 0.21\text{dB}$
4	All emissions,radiated(<1G)	$\pm 4.68\text{dB}$
5	All emissions,radiated(>1G)	$\pm 4.89\text{dB}$
6	Temperature	$\pm 0.5^\circ\text{C}$
7	Humidity	$\pm 2\%$

2. GENERAL INFORMATION

2.1 GENERAL DESCRIPTION OF EUT

Equipment	Remote control
Trade Mark	VISICO
Model Name	VC-16
Serial Model	N/A
Model Difference	N/A
Operating Frequency	2401MHz~2480MHz
Modulation Type:	GFSK
Antenna Type	PCB Antenna
Antenna Gain	0dBi
Channel List	Please refer to the Note 2.
Adapter	N/A
Battery	DC 2*1.5Vfrom AA battery
SW Version	N/A
HW Version	N/A

Note:

1. For a more detailed features description, please refer to the manufacturer's specifications or the User's Manual.

2.

Channel	Frequency (MHz)	Channel	Frequency (MHz)
01	2401	09	2452
02	2408	10	2456
03	2416	11	2460
04	2424	12	2464
05	2432	13	2468
06	2440	14	2472
07	2444	15	2476
08	2448	16	2480

2.2 DESCRIPTION OF TEST MODES

To investigate the maximum EMI emission characteristics generates from EUT, the test system was pre-scanning tested base on the consideration of following EUT operation mode or test configuration mode which possible have effect on EMI emission level. Each of these EUT operation mode(s) or test configuration mode(s) mentioned above was evaluated respectively.

Pretest Mode	Description
Mode 1	CH 01
Mode 2	CH 08
Mode 3	CH 16
Mode 4	Link mode

For Radiated Emission	
Final Test Mode	Description
Mode 1	CH 01
Mode 2	CH 08
Mode 3	CH 16

2.3 BLOCK DIGRAM SHOWING THE CONFIGURATION OF SYSTEM TESTED

Radiated Spurious Emission Test

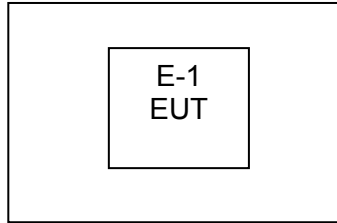

2.4 DESCRIPTION OF SUPPORT UNITS(CONDUCTED MODE)

The EUT has been tested as an independent unit together with other necessary accessories or support units. The following support units or accessories were used to form a representative test configuration during the tests.

Item	Equipment	Mfr/Brand	Model/Type No.	Series No.	Note
E-1	Remote control	VISICO	VC-16	N/A	EUT

Item	Shielded Type	Ferrite Core	Length	Note

Note:

- (1) The support equipment was authorized by Declaration of Confirmation.
- (2) For detachable type I/O cable should be specified the length in cm in 『Length』 column.

2.4.1 EQUIPMENTS LIST FOR ALL TEST ITEMS

Radiation Test equipment

Item	Kind of Equipment	Manufacturer	Type No.	Serial No.	Last calibration	Calibrated until	Calibration period
1	Spectrum Analyzer	Agilent	E4407B	160400005	Jul. 07. 2017	Jul. 06. 2018	1 year
2	Test Receiver	R&S	ESPI	101318	Jul. 07. 2017	Jul. 06. 2018	1 year
3	Bilog Antenna	TESEQ	CBL6111D	31216	Jul. 07. 2017	Jul. 06. 2018	1 year
4	50Ω Coaxial Switch	Anritsu	MP59B	6200264416	Jul. 07. 2017	Jul. 06. 2018	1 year
5	Spectrum Analyzer	ADVANTEST	R3132	150900201	Jul. 07. 2017	Jul. 06. 2018	1 year
6	Horn Antenna	EM	EM-AH-10180	2011071402	Jul. 07. 2017	Jul. 06. 2018	1 year
7	Horn Ant	Schwarzbeck	BBHA 9170	9170-181	Jul. 07. 2017	Jul. 06. 2018	1 year
8	Amplifier	EM	EM-30180	060538	Jul. 07. 2017	Jul. 06. 2018	1 year
9	Loop Antenna	ARA	PLA-1030/B	1029	Jul. 07. 2017	Jul. 06. 2018	1 year
10	Power Meter	R&S	NRVS	100696	Jul. 07. 2017	Jul. 06. 2018	1 year

Conduction Test equipment

Item	Kind of Equipment	Manufacturer	Type No.	Serial No.	Last calibration	Calibrated until	Calibration period
1	Test Receiver	R&S	ESCI	101160	Jul. 07. 2017	Jul. 06. 2018	1 year
2	LISN	R&S	ENV216	101313	Jul. 07. 2017	Jul. 06. 2018	1 year
3	LISN	EMCO	3816/2	00042990	Jul. 07. 2017	Jul. 06. 2018	1 year
4	50Ω Coaxial Switch	Anritsu	MP59B	6200264417	Jul. 07. 2017	Jul. 06. 2018	1 year
5	Passive Voltage Probe	R&S	ESH2-Z3	100196	Jul. 07. 2017	Jul. 06. 2018	1 year
6	Absorbing clamp	R&S	MOS-21	100423	Jul. 07. 2017	Jul. 06. 2018	1 year

3. ANTENNA REQUIREMENT

3.1 STANDARD REQUIREMENT

15.203 requirement: For intentional device, according to 15.203: an intentional radiator shall be designed to ensure that no antenna other than that furnished by the responsible party shall be used with the device.

3.2 EUT ANTENNA

The EUT antenna is PCB antenna, details to see internal photo, it comply with the standard requirement.

3.3 CONDUCTED EMISSION MEASUREMENT

3.3.1 POWER LINE CONDUCTED EMISSION Limits (Frequency Range 150KHz-30MHz)

FREQUENCY (MHz)	Class A (dBuV)		Class B (dBuV)		Standard
	Quasi-peak	Average	Quasi-peak	Average	
0.15 -0.5			66 - 56 *	56 - 46 *	CISPR
0.50 -5.0			56.00	46.00	CISPR
5.0 -30.0			60.00	50.00	CISPR

Note:

- (1) The tighter limit applies at the band edges.
- (2) The limit of " * " marked band means the limitation decreases linearly with the logarithm of the frequency in the range.

The following table is the setting of the receiver

Receiver Parameters	Setting
Attenuation	10 dB
Start Frequency	0.15 MHz
Stop Frequency	30 MHz
IF Bandwidth	9 kHz

3.3.2 TEST PROCEDURE

- a. The EUT was placed 0.4 meters from the horizontal ground plane with EUT being connected to the power mains through a line impedance stabilization network (LISN). All other support equipments powered from additional LISN(s). The LISN provide 50 Ohm/ 50uH of coupling impedance for the measuring instrument.
- b. Interconnecting cables that hang closer than 40 cm to the ground plane shall be folded back and forth in the center forming a bundle 30 to 40 cm long.
- c. I/O cables that are not connected to a peripheral shall be bundled in the center. The end of the cable may be terminated, if required, using the correct terminating impedance. The overall length shall not exceed 1 m.
- d. LISN at least 80 cm from nearest part of EUT chassis.
- e. For the actual test configuration, please refer to the related Item –EUT Test Photos.

3.3.3 DEVIATION FROM TEST STANDARD

No deviation

3.3.4 TEST SETUP

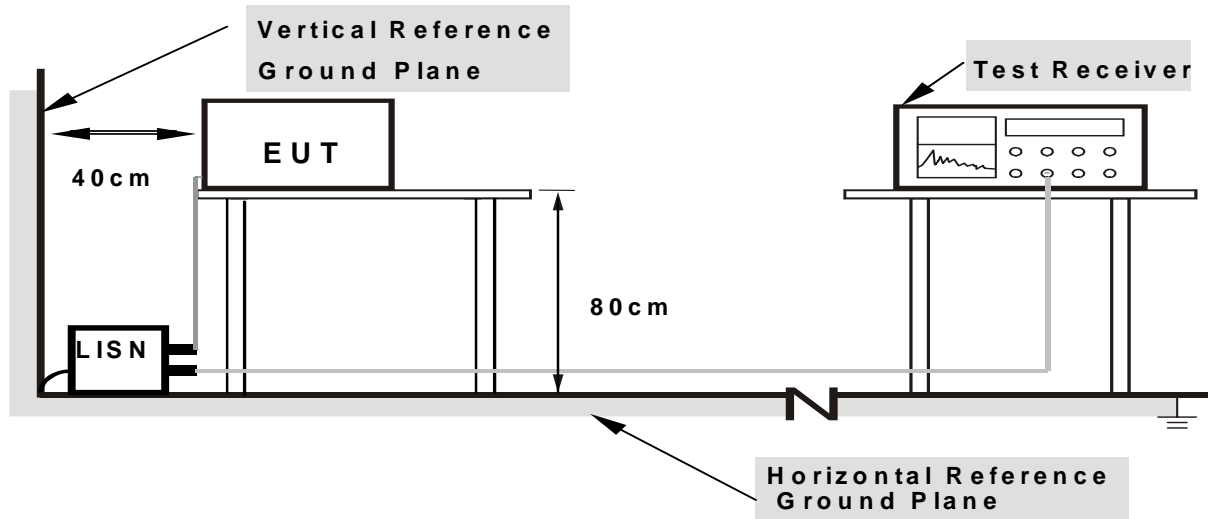

- Note:**
- 1. Support units were connected to second LISN.
 - 2. Both of LISNs (AMN) are 80 cm from EUT and at least 80 from other units and other metal planes

3.3.5 TEST RESULTS

Not applicable for equipment operated with battery power supply.

3.4 RADIATED EMISSION MEASUREMENT

3.4.1 Radiated Emission Limits (FCC 15.209)

Frequencies (MHz)	Field Strength (micorvolts/meter)	Measurement Distance (meters)
0.009~0.490	2400/F(KHz)	300
0.490~1.705	24000/F(KHz)	30
1.705~30.0	30	30
Frequency (MHz)	Limit (dBuV)	
30~88	40	3
88~216	43.5	3
216~960	46	3
960 -10000	54.00	3
*902 - 928	94.00	3

Note:

- (1) The tighter limit applies at the band edges.
- (2) Emission level (dBuV/m)=20log Emission level (uV/m).
- (3) *Note: This is the limit for the fundamental frequency.

LIMITS OF RADIATED EMISSION MEASUREMENT (FCC 15.249)

Frequency of Emission (MHz)	Field Strength of fundamental ((millivolts /meter)	Field Strength of Harmonics (microvolts/meter)
902-928	50	500

Notes:

- (1) Emissions radiated outside of the specified frequency bands, except for harmonics, shall be attenuated by at least 50 dB below the level of the fundamental or to the general radiated emission limits in Section 15.209, whichever is the lesser attenuation.

Spectrum Parameter	Setting
Attenuation	Auto
Start Frequency	1000 MHz
Stop Frequency	10th carrier harmonic
RB / VB (emission in restricted band)	1MHz / 1MHz for Peak

Receiver Parameter	Setting
Attenuation	Auto
Start ~ Stop Frequency	9kHz~150kHz / RB 200Hz for QP
Start ~ Stop Frequency	150kHz~30MHz / RB 9kHz for QP
Start ~ Stop Frequency	30MHz~1000MHz / RB 120kHz for QP

3.4.2 TEST PROCEDURE

- a. The measuring distance of at 3 m shall be used for measurements at frequency up to 1GHz. For frequencies above 1GHz, any suitable measuring distance may be used.
- b. The EUT was placed on the top of a rotating table 0.8 m for below 1GHz and 1.5m for above 1GHz the ground at a 3 meter open area test site. The table was rotated 360 degrees to determine the position of the highest radiation.
- c. The height of the equipment or of the substitution antenna shall be 0.8 m for below 1GHz and 1.5m for above 1GHz; the height of the test antenna shall vary between 1 m to 4 m. Both horizontal and vertical polarizations of the antenna are set to make the measurement.
- d. The initial step in collecting conducted emission data is a spectrum analyzer peak detector mode pre-scanning the measurement frequency range. Significant peaks are then marked and then Quasi Peak detector mode re-measured.
- e. If the Peak Mode measured value compliance with and lower than Quasi Peak Mode Limit, the EUT shall be deemed to meet QP Limits and then no additional QP Mode measurement performed.
- f. For the actual test configuration, please refer to the related Item –EUT Test Photos.

Note:

Both horizontal and vertical antenna polarities were tested and performed pretest to three orthogonal axis. The worst case emissions were reported

During the radiated emission test, the Spectrum Analyzer was set with the following configurations:

Frequency Band (MHz)	Function	Resolution bandwidth	Video Bandwidth
30 to 1000	Peak	100 kHz	100 kHz
Above 1000	Peak	1 MHz	1 MHz
	Average	1 MHz	10 Hz

3.4.3 DEVIATION FROM TEST STANDARD

No deviation

3.4.4 TEST SETUP

(A) Radiated Emission Test-Up Frequency Below 30MHz

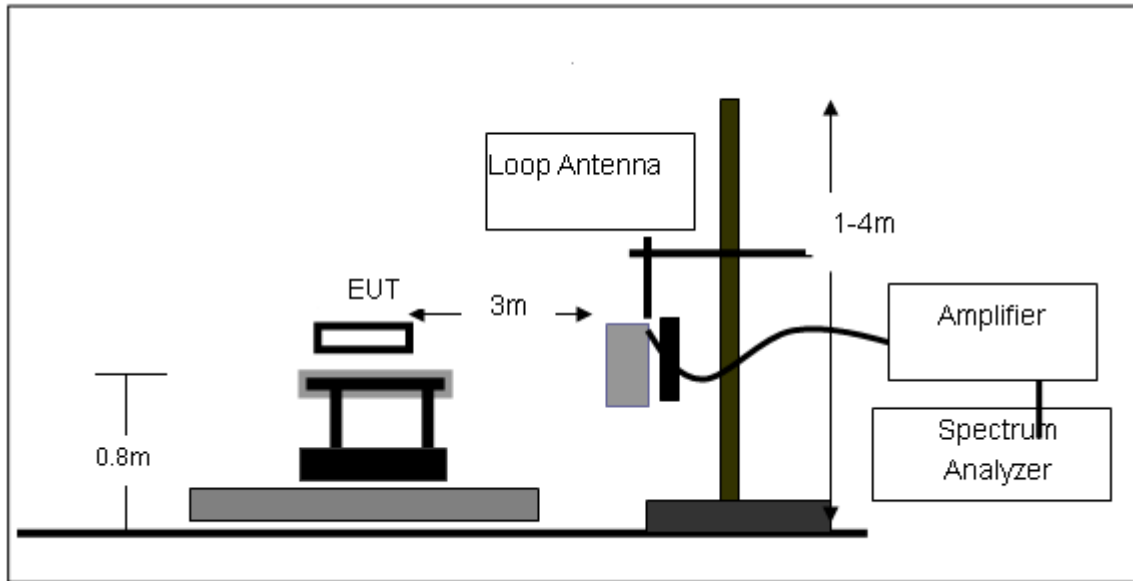

(B) Radiated Emission Test-Up Frequency 30MHz~1GHz

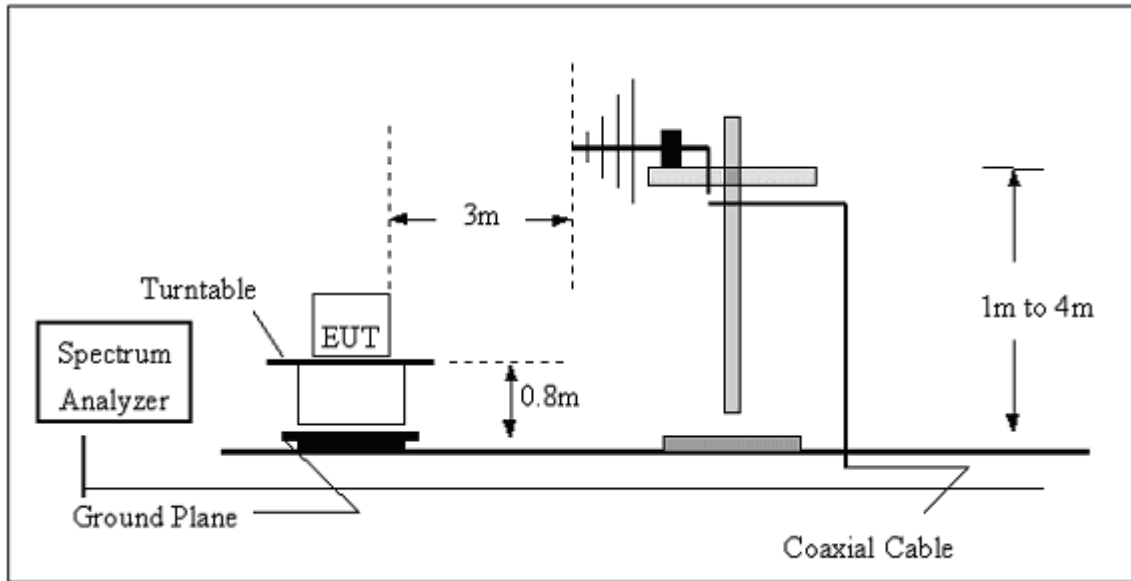

(C) Radiated Emission Test-Up Frequency Above 1GHz

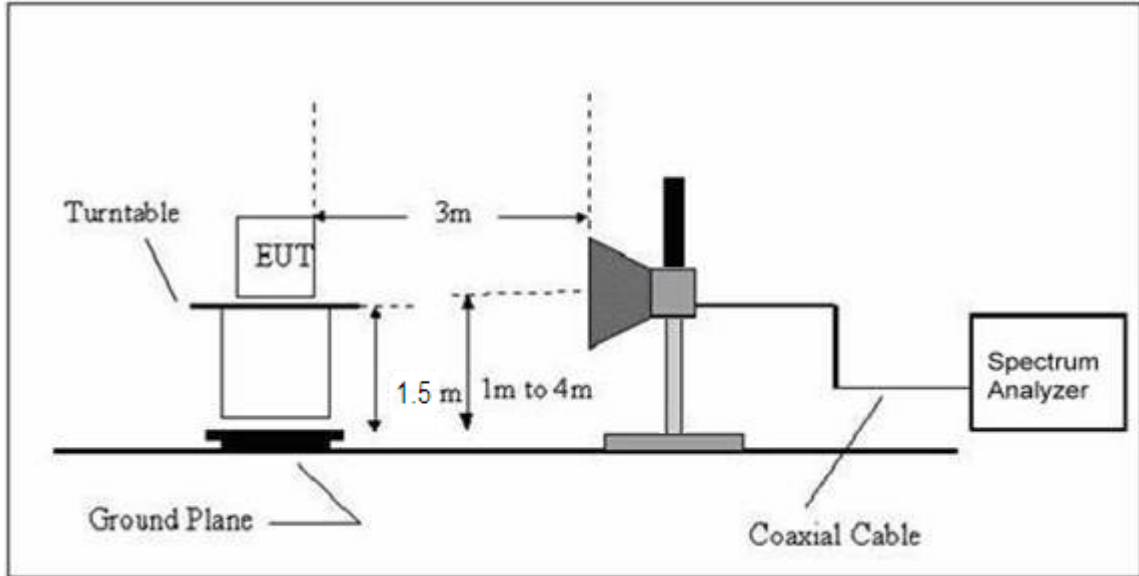

3.4.5 TEST RESULTS (BLOW 30MHz)

EUT :	Remote control	Model Name. :	VC-16
Temperature :	20 °C	Relative Humidity :	48%
Pressure :	1010 hPa	Test Voltage :	DC 3V
Test Mode :	TX	Polarization :	--

Freq.	Reading	Limit	Margin	State
(MHz)	(dBuV/m)	(dBuV/m)	(dB)	P/F
--	--	--	--	PASS
--	--	--	--	PASS

NOTE:

The amplitude of spurious emissions which are attenuated by more than 20dB below the permissible value has no need to be reported.

Distance extrapolation factor = $40 \log(\text{specific distance}/\text{test distance})$ (dB);

Limit line = specific limits(dBuv) + distance extrapolation factor.

3.4.6 TEST RESULTS (BETWEEN 30 – 1000 MHZ)

EUT :	Remote control	Model Name :	VC-16
Temperature :	20 °C	Relative Humidity :	48%
Pressure :	1010 hPa	Test Voltage :	DC 3V
Test Mode :	TX-2401	Polarization :	Vertical
Note :	This mode is worst case mode, and this report only reflected the worst mode.		

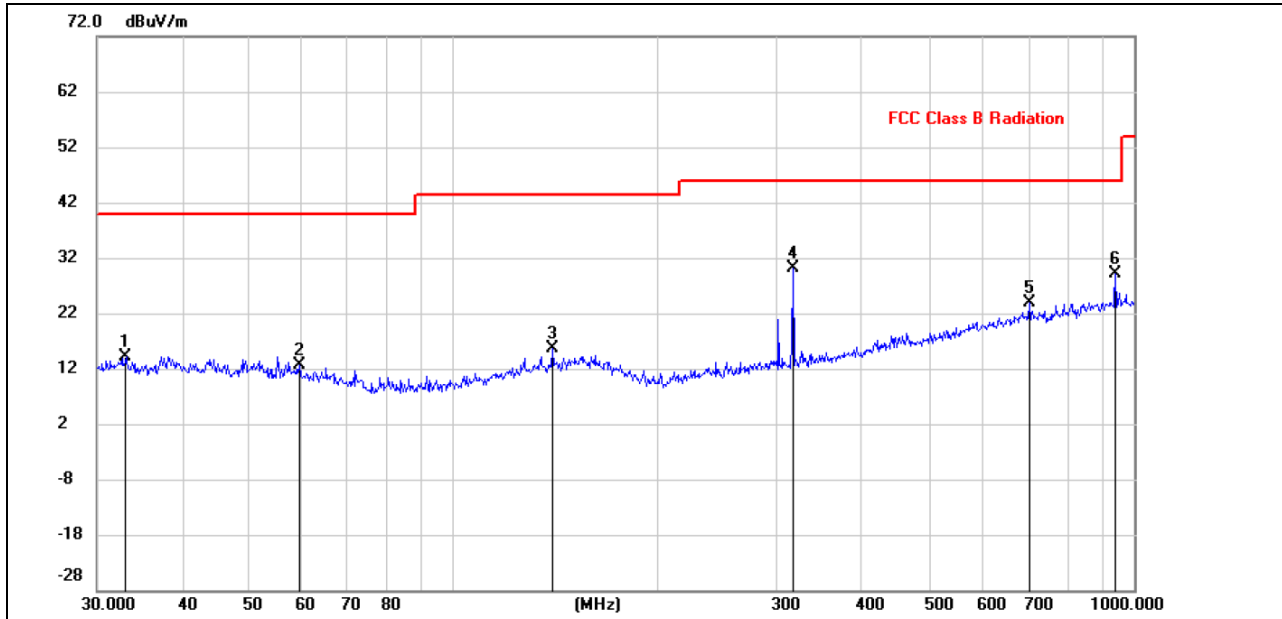

No.	Mk.	Freq.	Reading Level	Correct Factor	Measurement	Limit	Margin	Antenna Height	Table Degree
		MHz	dBuV	dB	dBuV/m	dBuV/m	dB	cm	degree
1		33.0949	0.80	13.44	14.24	40.00	-25.76	peak	
2		59.4405	-0.51	13.03	12.52	40.00	-27.48	peak	
3		139.8508	1.80	13.82	15.62	43.50	-27.88	peak	
4	*	316.5889	16.44	13.79	30.23	46.00	-15.77	peak	
5		701.7610	3.48	20.40	23.88	46.00	-22.12	peak	
6		938.8326	5.97	23.12	29.09	46.00	-16.91	peak	

Note:1. *:Maximum data; x:Over limit; !:over margin.
 2.Measurement=Reading Level+Correct Factor; Correct Factor=Antenna Factor+Cable Loss.

EUT :	Remote control	Model Name :	VC-16
Temperature :	20 °C	Relative Humidity :	48%
Pressure :	1010 hPa	Test Voltage :	DC 3V
Test Mode :	TX-2401	Polarization :	Horizontal

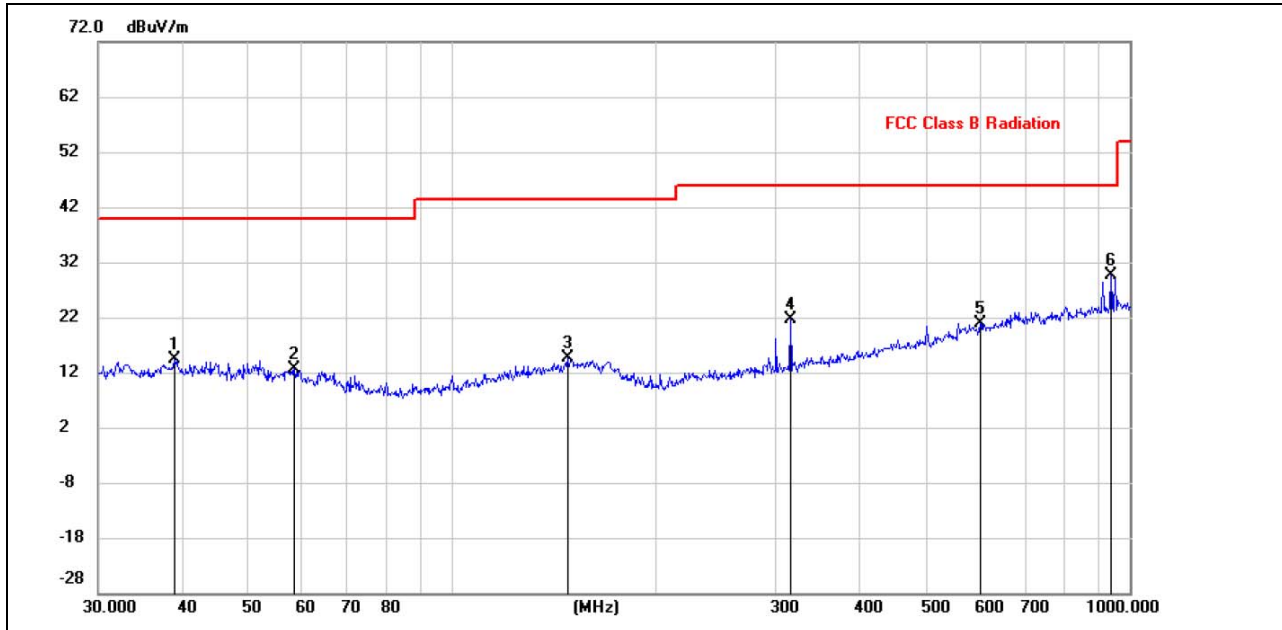

No. Mk.	Freq. MHz	Reading Level dBuV	Correct Factor dB	Measurement dBuV/m	Limit dBuV/m	Margin dB	Detector	Antenna Height cm	Table Degree	Comment
1	39.0244	0.27	14.20	14.47	40.00	-25.53	peak			
2	58.4074	-0.39	13.11	12.72	40.00	-27.28	peak			
3	147.9214	0.21	14.40	14.61	43.50	-28.89	peak			
4	316.5889	7.82	13.79	21.61	46.00	-24.39	peak			
5	601.4265	1.54	19.41	20.95	46.00	-25.05	peak			
6 *	938.8326	6.55	23.12	29.67	46.00	-16.33	peak			

Note: 1. *:Maximum data; x:Over limit; !:over margin.
 2.Measurement=Reading Level+Correct Factor; Correct Factor=Antenna Factor+Cable Loss.

3.4.7 TEST RESULTS (ABOVE 1000 MHZ)

EUT :	Remote control	Model Name :	VC-16
Temperature :	20 °C	Relative Humidity :	48%
Pressure :	1010 hPa	Test Voltage :	DC 3V
Test Mode :	TX-2401MHz		

No.	Freq MHz	Polarity	Reading (dBuV/m)	Correct Factor	Result (dBuV/m)	Limit (dBuV/m)	Margin	Remark
1	2401	H	95.69	-3.38	92.31	113.97	-21.66	Peak
2	2401	H	83.52	-3.38	80.14	93.97	-13.83	Avg
3	4802	H	43.21	3.23	46.44	74	-27.56	Peak
4	4802	H	--	3.23	--	54	--	Avg
5	7203	H	41.63	10.57	52.2	74	-21.80	Peak
6	7203	H	--	10.57	--	54	--	Avg

1	2401	V	102.96	-3.38	99.58	113.97	-14.39	Peak
2	2401	V	90.10	-3.38	86.72	93.97	-7.25	Avg
3	4802	V	46.97	3.23	50.2	74	-23.80	Peak
4	4802	V	--	3.23	--	54	--	Avg
5	7203	V	42.59	10.57	53.16	74	-20.84	Peak
6	7203	V	--	10.57	--	54	--	Avg

Note:

1. Means other frequency and mode comply with standard requirements and at least have 20dB margin.
2. Correct Factor=Cable Loss+ Antenna Factor-Amplifier Gain.
Result=Reading + Correct Factor.
Margin= Result-Limit.
3. Spectrum Set for PK measure: RBW=1MHz, VBW=1MHz, Sweep time=Auto, Detector: PK.
4. Spectrum Set for AV measure: RBW=1MHz, VBW=3MHz, Sweep time=Auto, Detector: Avg.
5. If the limits for the measurement with the average detector are met when using a receiver with a peak detector, the test unit shall be deemed to meet both limits and the measurement with the average detector need not be carried out.

Note: EUT Pre-scan X/Y/Z orientation, only worst case is presented in the report(X orientation).

EUT :	Remote control	Model Name :	VC-16
Temperature :	20 °C	Relative Humidity :	48%
Pressure :	1010 hPa	Test Voltage :	DC 3V
Test Mode :	TX-2448MHz		

No.	Freq MHz	Polarity	Reading (dBuV/m)	Correct Factor	Result (dBuV/m)	Limit (dBuV/m)	Margin	Remark
1	2448	H	97.45	-3.38	94.07	113.97	-19.90	Peak
2	2448	H	85.62	-3.38	82.24	93.97	-11.73	Avg
3	4896	H	44.17	3.23	47.40	74	-26.60	Peak
4	4896	H	--	3.23	--	54	--	Avg
5	7344	H	42.96	10.57	53.53	74	-20.47	Peak
6	7344	H	--	10.57	--	54	--	Avg

1	2448	V	103.48	-3.38	100.10	113.97	-13.87	Peak
2	2448	V	91.33	-3.38	87.95	93.97	-6.02	Avg
3	4896	V	47.21	3.23	50.44	74	-23.56	Peak
4	4896	V	--	3.23	--	54	--	Avg
5	7344	V	44.06	10.57	54.63	74	-19.37	Peak
6	7344	V	--	10.57	--	54	--	Avg

Note:

1. Means other frequency and mode comply with standard requirements and at least have 20dB margin.
2. Correct Factor=Cable Loss+ Antenna Factor-Amplifier Gain.
Result=Reading + Correct Factor.
Margin= Result-Limit.
3. Spectrum Set for PK measure: RBW=1MHz, VBW=1MHz, Sweep time=Auto, Detector: PK.
4. Spectrum Set for AV measure: RBW=1MHz, VBW=3MHz, Sweep time=Auto, Detector: Avg.
5. If the limits for the measurement with the average detector are met when using a receiver with a peak detector, the test unit shall be deemed to meet both limits and the measurement with the average detector need not be carried out.

Note: EUT Pre-scan X/Y/Z orientation, only worst case is presented in the report(X orientation).

EUT :	Remote control	Model Name :	VC-16
Temperature :	20 °C	Relative Humidity :	48%
Pressure :	1010 hPa	Test Voltage :	DC 3V
Test Mode :	TX-2480MHz	Polarization :	Horizontal

No.	Freq MHz	Polarity	Reading (dBuV/m)	Correct Factor	Result (dBuV/m)	Limit (dBuV/m)	Margin	Remark
1	2480	H	97.84	-3.38	94.46	113.97	-19.51	Peak
2	2480	H	86.01	-3.38	82.63	93.97	-11.34	Avg
3	4960	H	46.32	3.23	49.55	74	-24.45	Peak
4	4960	H	--	3.23	--	54	--	Avg
5	7440	H	45.21	10.57	55.78	74	-18.22	Peak
6	7440	H	--	10.57	--	54	--	Avg

1	2480	V	104.51	-3.38	101.13	113.97	-12.84	Peak
2	2480	V	90.47	-3.38	87.09	93.97	-6.88	Avg
3	4960	V	48.97	3.23	52.20	74	-21.80	Peak
4	4960	V	--	3.23	--	54	--	Avg
5	7440	V	45.64	10.57	56.21	74	-17.79	Peak
6	7440	V	--	10.57	--	54	--	Avg

Note:

1. Means other frequency and mode comply with standard requirements and at least have 20dB margin.
2. Correct Factor=Cable Loss+ Antenna Factor-Amplifier Gain.
Result=Reading + Correct Factor.
Margin= Result-Limit.
3. Spectrum Set for PK measure: RBW=1MHz, VBW=1MHz, Sweep time=Auto, Detector: PK.
4. Spectrum Set for AV measure: RBW=1MHz, VBW=3MHz, Sweep time=Auto, Detector: Avg.
5. If the limits for the measurement with the average detector are met when using a receiver with a peak detector, the test unit shall be deemed to meet both limits and the measurement with the average detector need not be carried out.

Note: EUT Pre-scan X/Y/Z orientation, only worst case is presented in the report(X orientation).

3.4.8 TEST RESULTS (RESTRICTED BANDS REQUIREMENTS)

EUT :	Remote control	Model Name :	VC-16
Temperature :	20 °C	Relative Humidity :	48%
Pressure :	1010 hPa	Test Voltage :	DC 3V
Test Mode :	TX-2401MHz		

No.	Freq MHz	Polarity	Reading (dBuV/m)	Correct Factor	Result (dBuV/m)	Limit (dBuV/m)	Margin	Remark
1	2390	H	41.23	-3.43	37.80	74	-36.20	Peak
2	2390	H	--	-3.43	--	54	--	Avg
3	2400	H	41.69	-3.41	38.28	74	-35.72	Peak
4	2400	H	--	-3.41	--	54	--	Avg

1	2390	V	40.89	-3.43	37.46	74	-36.54	Peak
2	2390	V	--	-3.43	--	54	--	Avg
3	2400	V	40.71	-3.41	37.30	74	-36.70	Peak
4	2400	V	--	-3.41	--	54	--	Avg

Test Mode : TX-2480MHz

Test Results : **PASS**

1	2483.5	H	46.63	-3.38	43.25	74	-30.75	Peak
2	2483.5	H	--	-3.38	--	54	--	Avg

1	2483.5	V	46.54	-3.38	43.16	74	-30.84	Peak
2	2483.5	V	--	-3.38	--	54	--	Avg

Note:

- Means other frequency and mode comply with standard requirements and at least have 20dB margin.
- Correct Factor=Cable Loss+ Antenna Factor-Amplifier Gain.
Result=Reading + Correct Factor, Margin= Result-Limit.
- Spectrum Set for PK measure: RBW=1MHz, VBW=1MHz, Sweep time=Auto, Detector: PK.
- Spectrum Set for AV measure: RBW=1MHz, VBW=3MHz, Sweep time=Auto, Detector: Avg.
- If the limits for the measurement with the average detector are met when using a receiver with a peak detector, the test unit shall be deemed to meet both limits and the measurement with the average detector need not be carried out.

4. BANDWIDTH TEST

4.1 TEST PROCEDURE

- a. The EUT was directly connected to the spectrum analyzer and antenna output port as show in the block diagram below,
- b. Spectrum Setting : RBW= 100KHz, VBW \geq RBW, Sweep time = Auto.

4.2 DEVIATION FROM STANDARD

No deviation.

4.3 TEST SETUP



4.4 TEST RESULTS

EUT :	Remote control	Model Name :	VC-16
Temperature :	26 °C	Relative Humidity :	53%
Pressure :	1020 hPa	Test Power :	DC 3V
Test Mode :	TX		

Test Channel	Frequency (MHz)	20 dBc Bandwidth (kHz)
CH01	2401	567.4
CH08	2448	561.6
CH16	2480	560.5

2401 MHz

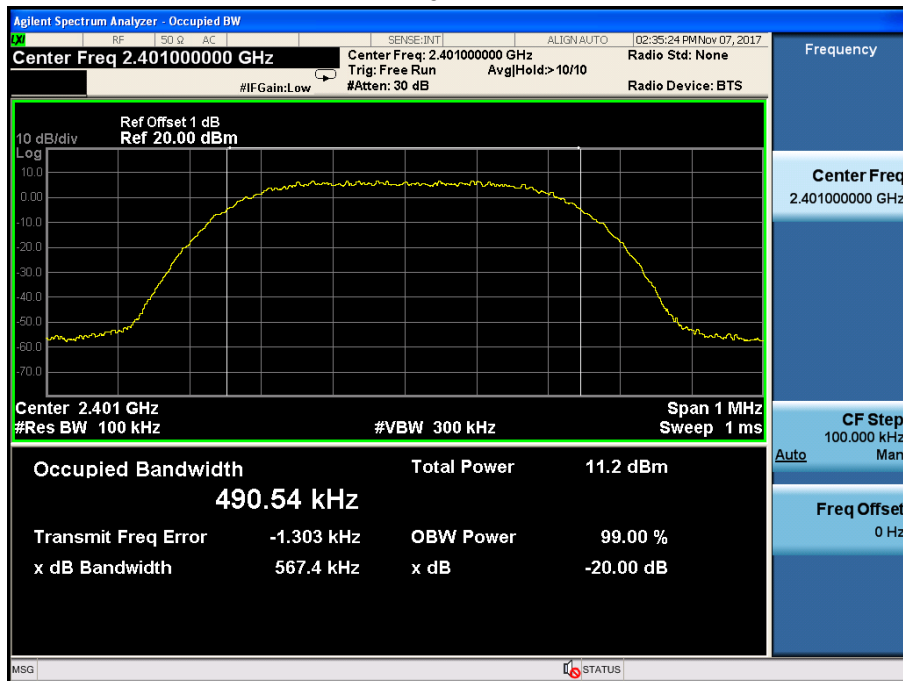

2448 MHz

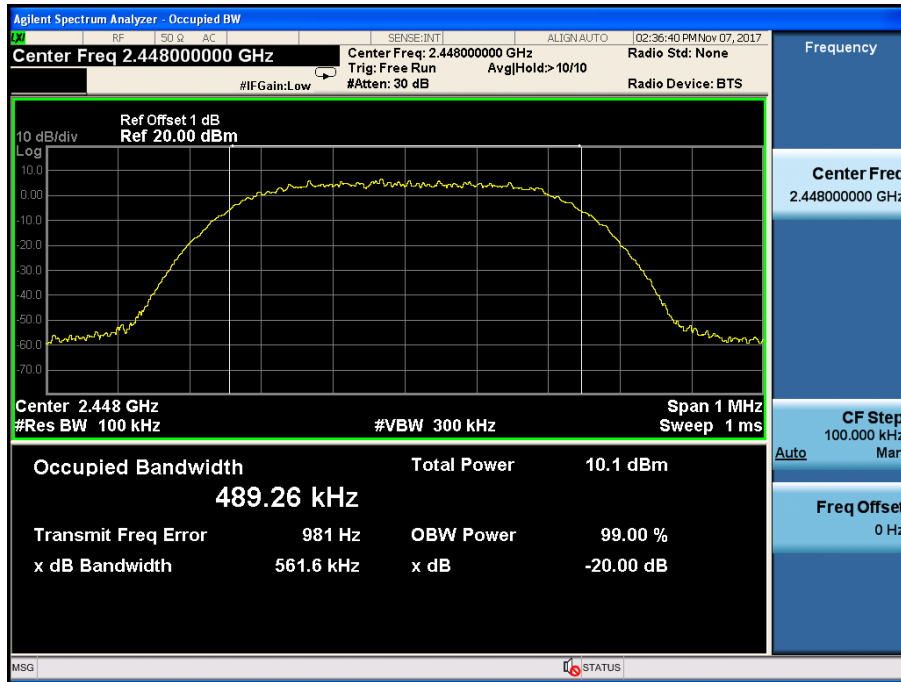

2480 MHz

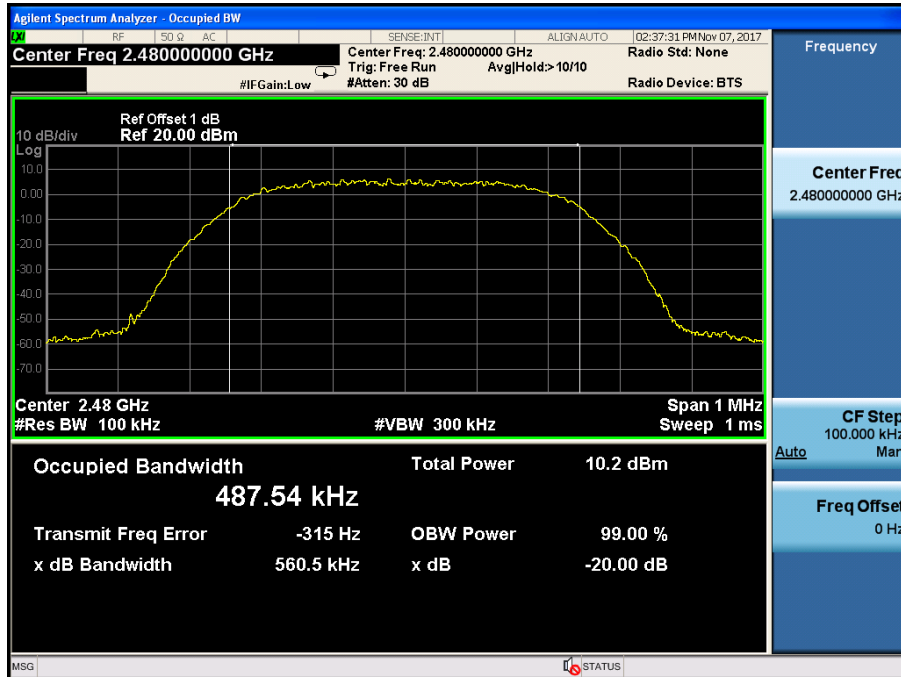

5. EUT TEST PHOTO

Radiated Measurement Photos

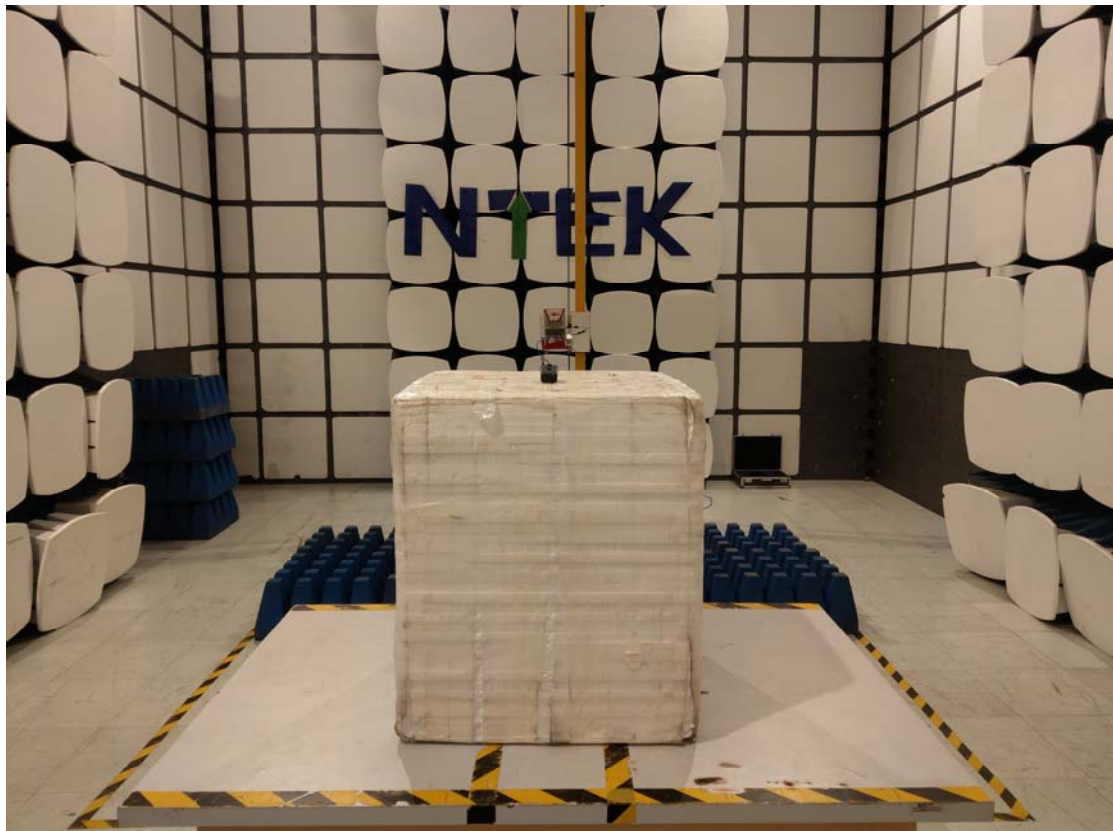
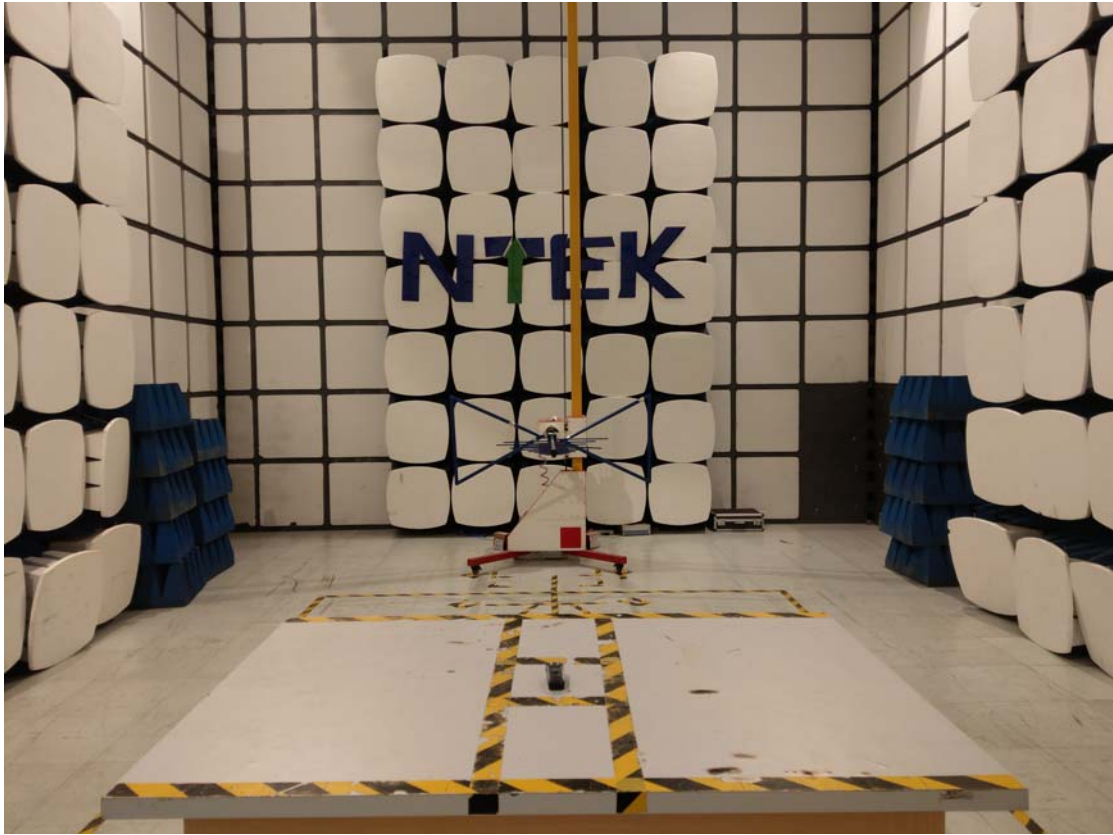

END OF REPORT