



**MODEL NO : WTM1D15 Transmitter of WPC QI EPP
ENGINEERING SPECIFICATION SHEET**

ACER

Purpose: This specification document represents the design criteria of the product identified herein, for the approval of the designated recipient (customer). Prior to production and delivery of this product by CWT, the customer shall endorse its approval of this specification document, upon review of the detailed information provided herein. The customer's endorsement (approval) verifies that the product description is determined to be fully compliant to the customer's design requirements. If one or more samples are included with this specification, the customer's endorsement (approval) further verifies that the product has been tested by the customer, for which the product satisfactorily meets all aesthetic, mechanical, electrical, and operating requirements for its intended usage with the customer's suitable indoor equipment or applications.

To Approve: An authorized employee or agent of the customer shall endorse approval of this specification. Please sign & date this cover-page, and initial each subsequent page in the lower left corner to signify all sections have been read and found to be acceptable. A completed, original copy (signed, dated, initialed) of this specification must be returned to CWT to record the approved customer design. The customer shall keep one or more copies for its records. Upon receipt, CWT shall manufacture the product to the approved customer design. If design revisions are otherwise required, a revised specification and/or modified samples shall be provided by CWT for the endorsement (approval) by the customer.

Approved

Customer Signed

Issued	Checked	Planned
Leo Chen		Dylan Ou

Channel Well Technology Co., Ltd.

ISSUE DATE: 2021-02-25	Revision No.: 0. 2	
Specification No: WTM1D15	Page: 1 of 16	



TABLE OF CONTENTS

1 SCOPE 4
1.1 GENERAL DESCRIPTION 4

2 ELECTRICAL SPECIFICATION 5
2.1 DESIGN STANDARDS 5
2.2 INPUT REQUIREMENT 5
2.3 OUTPUT REQUIREMENT 5
2.4 NO LOAD CONSUMPTION 5
2.5 EFFICIENCY 5
2.6 OVER TEMPERATURE PROTECTION 6
2.7 OVER VOLTAGE PROTECTION 6
2.8 FOD AND OTHER PROTECTION 6
2.9 FREQUENCY 6
2.10 INTERFACE SURFACE 6
 2.10.1 Distance 7
 2.10.2 Without metal 7
2.11 LED INDICATE 7

3 ENVIRONMENTAL SPECIFICATION 7
3.1 COOLING 7
3.2 TEMPERATURE 7
3.3 HUMIDITY 7
3.4 CALCULATED MEAN TIME BETWEEN FAILURES (MTBF) 8
3.5 WEIGHT 8

4 REGULATORY COMPLIANCE 8
4.1 EMC SPECIFICATION 8
 4.1.1 FCC requirements 8
 4.1.2 CISPR requirements 8
4.2 AGENCIES CERTIFICATIONS 8
 4.2.1 Product safety compliance 8

5 MECHANICAL 9

6 COIL(SPEC) 10

7 CABLE 10
7.1 CABLE(BOARD TO CONNECTOR) 10
7.2 CABLE(CONNECTOR TO CONNECTOR) 11

ISSUE DATE: 2021-02-25	Revision No.: 0. 2	
Specification No: WTM1D15	Page: 3 of 16	

1 SCOPE

This document describes the basic electrical characteristics of WTM1D15 wireless power transmitter module. WTM1D15 is designed based on the technology of electromagnetic induction.

It is a widely used module for many different applications. This is a new concept of charging devices without any wires and cords.

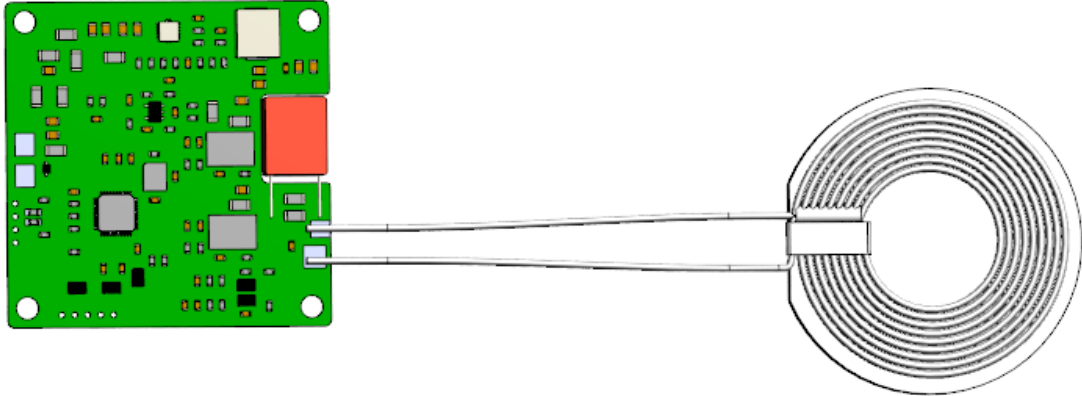

1.1 GENERAL DESCRIPTION

WTM1D15 is a Wireless Power Consortium (WPC) Qi 1.2.4 compatible wireless power transmitter module. This transmitter module is Qi certified and can function with devices compatible to Qi standard. This excellent and highly integrated transmitter module is using magnetic induction process technology with stable performance and high reliability. This specification defines the performance characteristics (include electrical function, EMC, safety, and product test requirements and so on) of a internal signal coil wireless charger (transmitter), which provide configurable charging mode to support WPC Qi 1.2.4 standard.

ISSUE DATE: 2021-02-25	Revision No.: 0.2	
Specification No: WTM1D15	Page: 4 of 16	



**MODEL NO : WTM1D15 Transmitter of WPC Qi EPP
ENGINEERING SPECIFICATION SHEET**

2 ELECTRICAL SPECIFICATION

2.1 DESIGN STANDARDS

WTM1D15 with follow WPC Qi Wireless Power Transfer System Power Class 0 Specification Power Transmitter MP-A11.

2.2 INPUT REQUIREMENT

The power supply must operate on a DC input voltage 12V with $\pm 5\%$ tolerance, Input current should lower than 2A.

Outpout power(W)	Intput voltage(Vdc)	Intput current(A)
10	12	2

Table 1 - Input Voltage Range

2.3 OUTPUT REQUIREMENT

The wireless charger can support WPC Qi V1.2.4, downward support EPP 10W, BPP 5W, Apple 7.5W, Samsung Fast Charge. The following specifications are defined with RX- WRM1A15 12V/0.833A 10W Output.

2.4 NO LOAD CONSUMPTION

Vin	Load	Power consumption
12	No Receiver	< 0.5W

Table 2 - No load consumption

2.5 EFFICIENCY

The efficiency shall be $\geq 75\%$ at 12V maximum loading, efficiency measurements are performed at coil center with 2mm vertical distance between TX coil and RX IDT P9221 COIL.

Load	Efficiency	Receiver
10W	75%	IDT P9221(WRM1A15 11.4~12.6Vout Range)

Table 3 – Efficiency

ISSUE DATE: 2021-02-25	Revision No.: 0. 2	
Specification No: WTM1D15	Page: 5 of 16	



2.6 OVER TEMPERATURE PROTECTION

Built-in temperature protection control, the surface temperature of the center point of the wireless charging zone > 65 degrees Celsius (about 60-70 degrees Celsius for continuous charging) will be over-temperature protected, and when the temperature drops, it will be auto-recover.

2.7 OVER VOLTAGE PROTECTION

Input voltage protection, please refer to the table below, when entering the protection, please remove the power supply and re-supply the correct voltage to restore.

Input Range	Minimum	Nominal	Maximum	Unit
Nominal	11.4	12	12.6	Vdc
Protection	< 11.0		> 13.5	Vdc

2.8 FOD AND OTHER PROTECTION

When an abnormality occurs, please remove the foreign object, remove the device, and re-align the charging area to automatically reply to the charging.

2.9 FREQUENCY

The Operating Frequency is 120~130 kHz

Parameter	Minimum	Target	Maximum	Unit	Comment
f_{op}	120	125	130	kHz	Type MP-A11 Power Transmitter

2.10 INTERFACE SURFACE

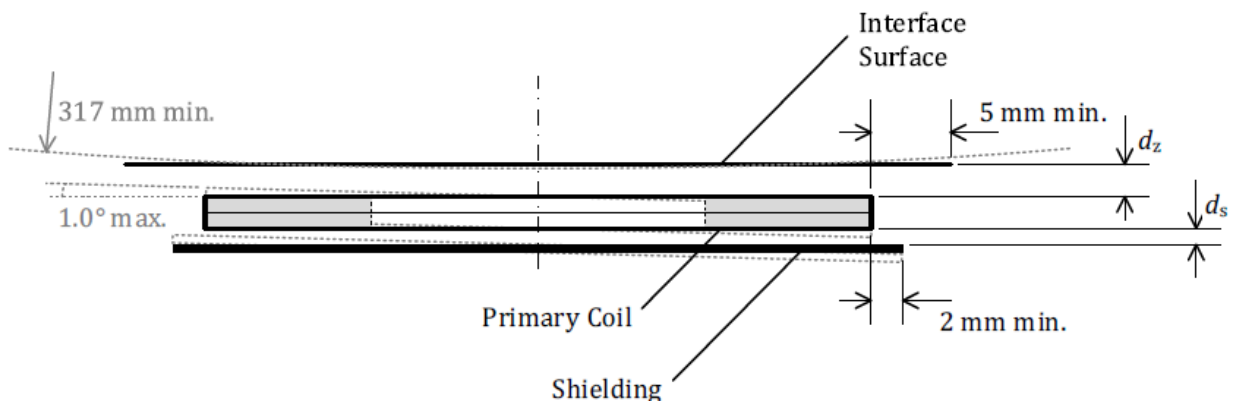

ISSUE DATE: 2021-02-25

Revision No.: 0. 2

Specification No: WTM1D15

Page: 6 of 16



2.10.1 DISTANCE

Distance from the Primary Coil to the Interface Surface of the Base Station is $dz = 2.5 \pm 0.5$ mm across the top face of the Primary Coil.

2.10.2 WITHOUT METAL

The Interface Surface of the Base Station extends at least 5.0 mm beyond the outer dimensions of the Primary Coil.

2.11 LED INDICATE

LED*/Color	Standby	Transfer	Charge Complete	Fault Condition
LED2-Blue	OFF	Blink 1Hz	ON	OFF
LED1-Red	OFF	OFF	OFF	Blink 4Hz

Table 4 - LED indicate

3 ENVIRONMENTAL SPECIFICATION

3.1 COOLING

Natural Air Cooling

3.2 TEMPERATURE

Operation within specification: 0 to 50 degrees C.

Storage: -20 to 85°C

Short Duration Storage Temperature Limits (ie. Shipping) -40 to +85°C

3.3 HUMIDITY

Operation: 10% to 85% relative humidity, non-condensation.

Storage: 10% to 85% relative humidity, including condensation.

ISSUE DATE: 2021-02-25	Revision No.: 0. 2	
Specification No: WTM1D15	Page: 7 of 16	



**MODEL NO : WTM1D15 Transmitter of WPC QI EPP
ENGINEERING SPECIFICATION SHEET**

3.4 CALCULATED MEAN TIME BETWEEN FAILURES (MTBF)

WTM1D15 shall have a calculated MTBF of greater than 400,000 hours, calculated utilizing Telcordia SR-332 issue 2 with the following assumptions:

Output load: Rated full load

Ambient temperature: 25 degrees C

3.5 WEIGHT

<60g

4 REGULATORY COMPLIANCE

4.1 EMC SPECIFICATION

4.1.1 FCC REQUIREMENTS

WTM1D15 shall comply with the radiated and conducted emission requirements for FCC Part 15 Class B.

4.1.2 CISPR REQUIREMENTS

WTM1D15 shall comply with the radiated and conducted emission requirements for CISPR 22 Class B.

4.2 AGENCIES CERTIFICATIONS

The WTM1D15 is designed to meet Comply to WPC QI V1.2.4 EPP compliance testing, and will also be tested by the relevant verification unit

4.2.1 PRODUCT SAFETY COMPLIANCE

Certification	Certification
FCC(option)	CE(option)
NCC(option)	BSMI(option)
	WPC QI EPP(option)

Table 5 - safety compliance

ISSUE DATE: 2021-02-25	Revision No.: 0. 2	
Specification No: WTM1D15	Page: 8 of 16	



5 MECHANICAL

Refer to drawing

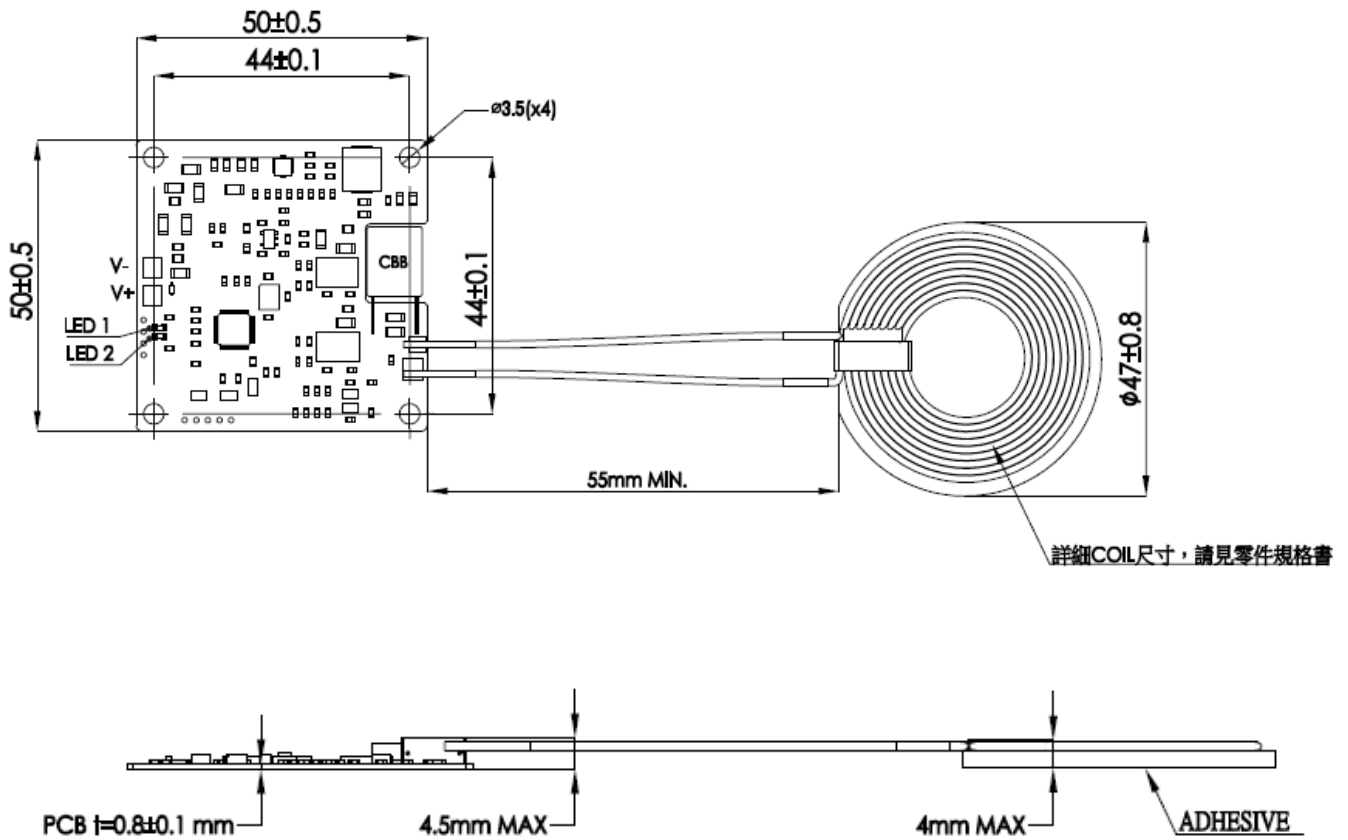

ISSUE DATE: 2021-02-25

Revision No.: 0.2

Specification No: **WTM1D15**

Page: 9 of 16

6 COIL(SPEC)

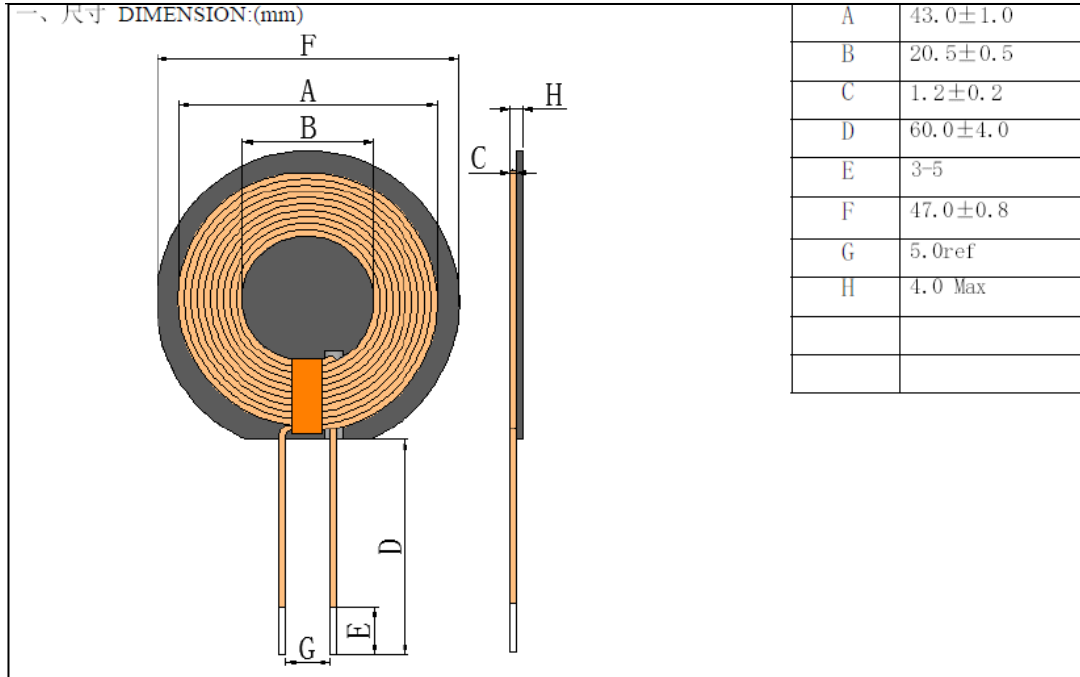

7 CABLE

7.1 CABLE(BOARD TO CONNECTOR)

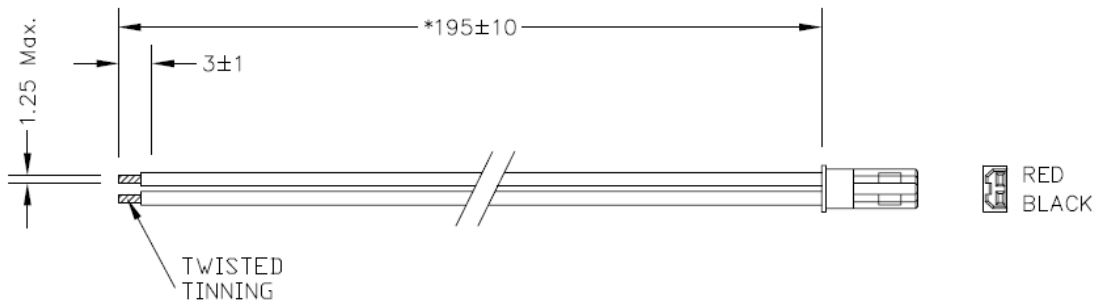

備註:

- 1.CONN.: JST SYP-02T-1 或同級品 (UL94V-2)(紅色).
- 2.WIRE: UL1007, 20AWG, 80°C 300V.

ISSUE DATE: 2021-02-25	Revision No.: 0. 2	
Specification No: WTM1D15	Page: 10 of 16	



**MODEL NO : WTM1D15 Transmitter of WPC QI EPP
ENGINEERING SPECIFICATION SHEET**

7.2 CABLE(CONNECTOR TO CONNECTOR)

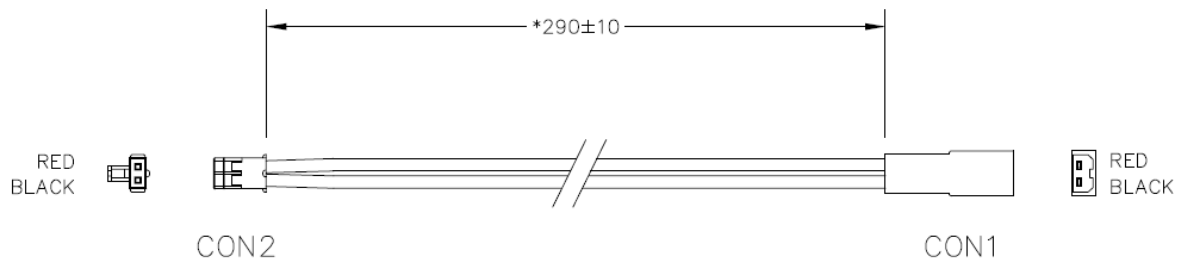

備註:

- 1.CON1: JST SYR-02T 或同級品 (UL94V-2)(紅色).
- 2.CON2: JWT A2008H00-2P 或同級品 (UL94V-2)(白色).
- 3.WIRE: UL1007, 20AWG, 80°C 300V.

ISSUE DATE: 2021-02-25

Revision No.: **0.2**

Specification No: **WTM1D15**

Page: 11 of 16



FCC

Federal Communications Commission (FCC) Statement

15.19

This device complies with Part 15 of the FCC Rules.

Operation is subject to the following two conditions:

- 1) this device may not cause harmful interference and
- 2) this device must accept any interference received, including interference that may cause undesired operation of the device.

15.21

You are cautioned that changes or modifications not expressly approved by the part responsible for compliance could void the user's authority to operate the equipment.

15.105(b)

This equipment has been tested and found to comply with the limits for a Class B digital device, pursuant to part 15 of the FCC rules. These limits are designed to provide reasonable protection against harmful interference in a residential installation. This equipment generates, uses and can radiate radio frequency energy and, if not installed and used in accordance with the instructions, may cause harmful interference to radio communications. However, there is no guarantee that interference will not occur in a particular installation. If this equipment does cause harmful interference to radio or television reception, which can be determined by turning the equipment off and on, the user is encouraged to try to correct the interference by one or more of the following measures:

- Reorient or relocate the receiving antenna.
- Increase the separation between the equipment and receiver.
- Connect the equipment into an outlet on a circuit different from that to which the receiver is connected.
- Consult the dealer or an experienced radio/TV technician for help

Additional testing, Part 15 Subpart B disclaimer

The modular transmitter is only FCC authorized for the specific rule parts (i.e., FCC transmitter rules) listed on the grant, and that the host product manufacturer is responsible for compliance to any other FCC rules that apply to the host not covered by the modular transmitter grant of certification.

Applicable rule part

The final host product still requires Part 15 Subpart B compliance testing with the modular transmitter installed.

This module has been tested and found to comply with the following requirements for Modular Approval.

- Part 15.209 – Radiated emission limits; general requirements.
- Part 15.215 – Additional provisions to the general radiated emission limitations.

ISSUE DATE: 2021-02-25	Revision No.: 0. 2	
Specification No: WTM1D15	Page: 12 of 16	



Test Modes

This device uses various test mode programs for test set up which operate separate from production firmware. Host integrators should contact the grantee for assistance with test modes needed for module/host compliance test requirements.

Limited Module

This modular is a limited single modular as without its own RF shielding. This module must be evaluated when being installed in hosts that to ensure compliance of rule Part 15 B and C; host manufacturer have to consult with module manufacturer for the module limiting conditions when integrate the module in the host. Module manufacturer should reviews detailed test data or host designs prior to giving the host manufacturer approval.

Antenna

A permanently attached coil antenna is approved for use with this module.

FCC/IC RF Radiation Exposure Statement:

1. This Transmitter must not be co-located or operating in conjunction with any other antenna or transmitter.
2. This equipment complies with RF radiation exposure limits set forth for an uncontrolled environment. This equipment should be installed and operated with a minimum distance of 15 cm between the radiator and your body.
1. Cet émetteur ne doit pas être situé au même endroit ou fonctionner en conjonction avec une autre antenne ou un autre émetteur.
2. Cet équipement est conforme aux limites d'exposition aux rayonnements IC définies pour un environnement non contrôlé. Cet équipement doit être installé et utilisé à une distance minimale de 15 cm entre le radiateur et votre corps.

LABEL OF THE END PRODUCT:

The final end product must be labeled in a visible area with the following” Contains TX FCC ID: 2AC3UWTM1D15”.

IC ID Number: 26897-WTM1D15

ISSUE DATE: 2021-02-25	Revision No.: 0. 2	
Specification No: WTM1D15	Page: 13 of 16	



**MODEL NO : WTM1D15 Transmitter of WPC QI EPP
ENGINEERING SPECIFICATION SHEET**

This device complies with Industry Canada license-exempt RSS standard(s). Operation is subject to the following two conditions:

- (1) this device may not cause interference, and
- (2) this device must accept any interference, including interference that may cause undesired operation of the device.

Cet appareil est conforme aux normes RSS exempts de licence d'Industrie Canada. Son fonctionnement est soumis aux deux conditions suivantes:

- (1) cet appareil ne doit pas causer d'interférences et
- (2) cet appareil doit accepter toute interférence, y compris les interférences pouvant provoquer un fonctionnement indésirable de l'appareil.

ISSUE DATE: 2021-02-25	Revision No.: 0.2	
Specification No: WTM1D15	Page: 14 of 16	



**MODEL NO : WTM1D15 Transmitter of WPC QI EPP
ENGINEERING SPECIFICATION SHEET**

NCC

取得審驗證明之低功率射頻器材，非經核准，公司、商號或使用者均不得擅自變更頻率、加大功率或變更原設計之特性及功能。

低功率射頻器材之使用不得影響飛航安全及干擾合法通信；經發現有干擾現象時，應立即停用，並改善至無干擾時方得繼續使用。

前述合法通信，指依電信管理法規定作業之無線電通信。低功率射頻器材須忍受合法通信或工業、科學及醫療用電波輻射性電機設備之干擾。

此模組若安裝於其他平台內時，該平台標籤需標明：

此平台內建無線模組

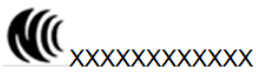

ISSUE DATE: 2021-02-25	Revision No.: 0.2	
Specification No: WTM1D15	Page: 15 of 16	



EU-TEC

1. RF Technical Specification

Item	Specification
Modulation Type	FSK
Frequency of Operation	120kHz-130kHz
RF Output Power	4.0 dB μ A/m at 10m (For Europe)
Antenna Type	Loop Coil antenna



CE Conformity Notice:

Hereby declares that this Wireless Power Transmitter Module in compliance with the essential requirements and other relevant provision of Directive 2014/53/EU

ISSUE DATE: 2021-02-25	Revision No.: 0.2	
Specification No: WTM1D15	Page: 16 of 16	