

**COMPLIANCE WORLDWIDE INC.
TEST REPORT 151-21**

**In Accordance with the Requirements of
Federal Communications Commission CFR Title 47
Part 15.249, Subpart C**

**Innovation, Science and Economic Development Canada
RSS 210, Issue 10**

**Low Power License-Exempt Radio Communication Devices
Intentional Radiators**

**Issued to
Building 36 Technologies
150 A Street – Suite 104
Needham, MA 02494
781-474-0500**

**for the
ADC-T40 Thermostat
Z-Wave Radio**

**FCC ID: 2AC3T-B36T40RA
IC: 12323A-B36T40RA**

Report Issued on March 31, 2021

Prepared by

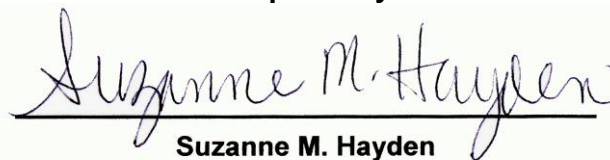

Suzanne M. Hayden

Reviewed By



Larry K. Stillings

This test report shall not be reproduced, except in full, without written permission from Compliance Worldwide, Inc.

Table of Contents

1. Scope.....	3
2. Product Details.....	3
2.1. Manufacturer	3
2.2. Model Number	3
2.3. Serial Number.....	3
2.4. Description of EUT	3
2.5. Power Source	3
2.6. Hardware Revision	3
2.7. Software Revision.....	3
2.8. Modulation Type	3
2.9. Operating Frequency	3
2.10. EMC Modifications.....	3
3. Product Configuration.....	3
3.1. EUT Hardware.....	3
3.2. Support Equipment.....	3
3.3. Cables	3
3.4. Operational Characteristics & Software	4
3.5. Block Diagram	4
4. Measurements Parameters	4
4.1. Measurement Equipment Used to Perform Test	4
4.2. Software Used to Perform Test.....	5
4.3. Measurement & Equipment Setup	5
4.4. Measurement Procedure	5
4.5. Choice of Operating Frequencies	5
4.6. EUT Positions for Emissions Measurements	5
5. Measurement Summary	6
6. Measurement Data.....	6
6.1. Antenna Requirement.....	6
6.2. Radiated Field Strength of Fundamental.....	7
6.3. Radiated Field Strength of Harmonics	9
6.4. Band Edge Measurements	10
6.5. Spurious Radiated Emissions	12
6.6. Occupied Bandwidth.....	13
6.7. 99% Emission Bandwidth	15
6.8. Conducted Emissions	17
6.9. Public Exposure to Radio Frequency Energy Levels.....	22
7. Test Setup Photographs.....	24
8. Test Site Description	31
Appendix A.....	32
Appendix B.....	37

1. Scope

This test report certifies that the Building 36 Technologies ADC-T40 Thermostat, Model ADC-T40, as tested, meets the FCC Part 15, Subpart C and Industry Canada RSS 210, Issue 10 requirements. The scope of this test report is limited to the test sample provided by the client, only in as much as that sample represents other production units. If any significant changes are made to the unit, the changes shall be evaluated and a retest may be required.

2. Product Details

- 2.1. Manufacturer:** Building 36 Technologies
- 2.2. Model Number:** ADC-T40
- 2.3 Serial Number:** SA0010210A01000005
- 2.4 Description of EUT:** Wireless Thermostat
- 2.5 Power Source:** 24 VAC, from HVAC Equipment
For test purposes, a 24 VAC wall power supply was substituted.
- 2.6 Hardware Revision:** Rev 3
- 2.7 Software Revision:** N/A
- 2.8. Modulation Type:** Gaussian frequency shift keying
- 2.9. Operating Frequencies:** 908.4 MHz and 916 MHz
- 2.10. EMC Modifications:** None

3. Product Configuration

3.1. EUT Hardware

Manufacturer	Model	Serial Number	Input Volts	Freq (Hz) Or DC	Description/Function
Building 36 Technologies	ADC-T40	SA0010210A01000005	24	60	Wireless Thermostat

3.2. Support Equipment

Device	Manufacturer	Model	Serial No.	Comment
24 VAC Transformer	MG Electronics	MGT2420	1805C	AC Power for EUT
Laptop	Lenovo	P50	PC0MHJ8Y	For setting up EUT

3.3. Cables

Cable Type	Length	Shield	From	To
Power Cable	3M	No	EUT	120 VAC / 24 VAC Transformer

3. Product Configuration (continued)

3.4. Operational Characteristics & Software

Apply 24 VAC to the device under test.

A proprietary software, provided by Silicon Labs for EMC testing, called MicroRFLink is used to configure the frequency, modulation type and bandwidth of the DUT. The device will be configured using this software to modulate test frequencies at 908.4 MHz and 916 MHz.

3.5. Block Diagram

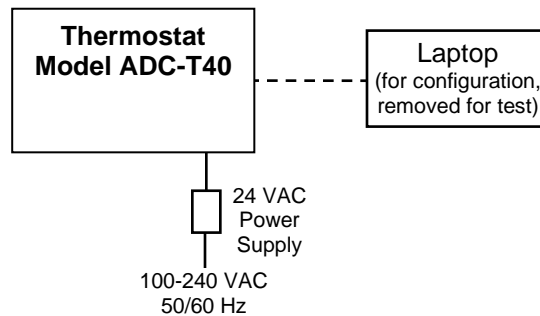

4. Measurements Parameters

4.1. Measurement Equipment Used to Perform Test

Device	Manufacturer	Model No.	Serial No.	Cal Due	Interval
EMI Test Receiver, 9kHz - 7GHz ¹	Rohde & Schwarz	ESR7	101156	10/16/2022	2 Years
EMI Test Receiver, 10 Hz - 7GHz ¹	Rohde & Schwarz	ESR7	101770	7/17/2022	2 Years
Spectrum Analyzer, 2 Hz to 26.5 GHz ²	Rohde & Schwarz	FSW26	102057	9/13/2021	3 Years
Spectrum Analyzer, 9 kHz to 40 GHz ³	Rohde & Schwarz	FSV40	100899	8/12/2022	2 Years
Spectrum Analyzer 10 Hz – 40 GHz ¹	Rohde & Schwarz	FSVR40	100909	9/18/2022	2 Years
Loop Antenna 9 kHz - 30 MHz	EMCO	6512	9309-1139	1/28/2022	3 Years
Biconilog Antenna, 30 MHz - 2 GHz	Sunol Sciences	JB1	A050913	6/5/2021	2 Years
Dbl Ridged Guide Antenna 1- 18 GHz	ETS-Lindgren	3117	00143292	3/21/2022	2 Years
Horn Antenna, 18 GHz to 40 GHz	Com-Power	AH-840	101032	9/8/2021	3 Years
Preamplifier, 1 GHz to 26.5 GHz	Hewlett Packard	8449B	3008A01323	9/11/2021	3 Years
1.8 GHz - 9.3 GHz Passband Filter	Mini-Circuits	VHP-16	0341	3/23/2022	2 Years
Band Reject Filter (Notch), 2.4 GHz	Micro-Tronics	BRM50702	150	3/23/2022	2 Years
Digital Barometer	Control Company	4195	ID236	4/3/2021	3 Years
Temperature Chamber	Associated Environmental	SD-308	10782	CNR	

¹ ESR7 Firmware revision: V3.48 SP3, Date installed: 09/30/2020

² FSW26 Firmware revision: V4.71 SP1, Date installed: 11/16/2020

³ FSV40 Firmware revision: V2.30 SP4, Date installed: 05/04/2016

⁴ FSVR40 Firmware revision: V2.23 SP1, Date installed: 08/19/2016

Previous V3.48 SP2, installed 07/23/2020.

Previous V4.61, installed 08/11/2020.

Previous V2.30 SP1, installed 10/22/2014.

Previous V2.23, installed 10/22/2014.

4. Measurements Parameters (continued)

4.2. Software Used to Perform Test

Manufacturer	Software Description	Title or Model #	Rev.	Report Sections
Compliance Worldwide	Test Report Generation Software	Test Report Generator	1.0	Used to process conducted emissions data

4.3. Measurement & Equipment Setup

Test Dates:	3/19/2021 – 4/1/2021
Test Engineers:	Sean Defelice
Normal Site Temperature (15 - 35°C):	21.2
Relative Humidity (20 -75%RH):	35
Frequency Range:	30 kHz to 9.4 GHz
Measurement Distance:	3 Meters
	200 Hz – 9 to 150 kHz
EMI Receiver IF Bandwidth:	9 kHz – 150 kHz to 30 MHz
	120 kHz - 30 MHz to 1 GHz
	1 MHz - Above 1 GHz
EMI Receiver Average Bandwidth:	$\geq 3 * \text{IF (BW) or RBW}$
Detector Function:	Peak, Quasi-Peak & Average

4.4. Measurement Procedures

Test measurements were made in accordance FCC Part 15.249, ISED RSS-210 B.10: Operation within the bands 902 - 928 MHz, 2400 - 2483.5 MHz, 5725 - 5875 MHz, and 24.0 - 24.25 GHz.

The test methods used to generate the data in this test report are in accordance with ANSI C63.10: 2013, American National Standard for Testing Unlicensed Wireless Devices.

ISED RSS-210, Issue 10; RSS-GEN, Issue 5

4.5. Choice of Operating Frequencies

The device under test utilizes two operating frequencies: 908.4 MHz and 916 MHz. Both frequencies were tested.

4.6. EUT Positions for Emissions Measurements

The device under test is designed to be mounted in a single orientation on a wall. Therefore, testing in three orthogonal positions in accordance with ANSI C63.10-2013, Section 5.10.1 was not required.

5. Measurement Summary

Test Requirement	FCC Requirement	ISED Requirement	Test Section	Result	Comment
Antenna Requirement	15.203	RSS-GEN 6.7	6.1	Compliant	
Radiated Field Strength of Fundamental	15.249 (a),(c)	RSS-210 B.10	6.2	Compliant	
Radiated Field Strength of Harmonics	15.249 (a),(c)	RSS-210 B.10	6.3	Compliant	
Fixed, Point-to-Point Operation	15.249 (b)	N/A	---	Not Required	
Band Edge Measurements	15.249 (d) 15.209	N/A	6.4	Compliant	
Spurious Radiated Emissions	15.249 (d), 15.209	RSS-210 B.10	6.5	Compliant	
Occupied Bandwidth (-20 dB)	ANSI C63.4 § 13.1.7	N/A	6.6	Compliant	
99% Power Bandwidth	N/A	RSS-GEN 6.6	6.7	Compliant	
AC Power Line Conducted Emissions	15.207	RSS-GEN 8.8	6.8	Compliant	
RF Safety	2.1093 1.1307 (b)(1))	RSS-102 Issue 5	6.9	Compliant	

6. Measurement Data

6.1. Antenna Requirement (Section 15.203, RSS-GEN, Issue 5)

Requirement: An intentional radiator shall be designed to ensure that no antenna other than that furnished by the responsible party shall be used with the device. The use of a permanently attached antenna or of an antenna that uses a unique coupling to the intentional radiator shall be considered sufficient to comply with the provisions of this Section.

Result: The unit under test utilizes an internal, non-user accessible antenna.

6. Measurement Data (continued)

6.2. Radiated Field Strength of Fundamental (15.249, Section (a), (c), ISED RSS-210 B.10)

Requirement: The 3 meter field strength of the fundamental emissions from intentional radiators operating within the 2400 – 2483.5 MHz frequency band shall comply with the following requirement: 50 millivolts/meter (94 dB μ V/m) Quasi-Peak mode measurement and 500 millivolts/meter (114 dB μ V/m) peak mode measurement.

Frequency (MHz)	Amplitude ¹ (dB μ V/m) at 3 Meters		Limit (dB μ V/m) at 3 Meters		Margin (dB μ V/m) at 3 Meters		Ant Polarity	Ant Height	Turntable Azimuth	Result
	Peak	Quasi-Pk	Peak	Quasi-Pk	Peak	Quasi-Pk	H/V	cm	Deg	
908.4	91.13	91.07	114.00	94.00	-22.87	-2.93	H	100	190	Compliant
916.0	91.58	91.47	114.00	94.00	-22.42	-2.53	H	100	190	Compliant

¹ All correction factors are included in measurement values.

6.2.1. Radiated Field Strength of Fundamental, 908.4 MHz (Worst case)

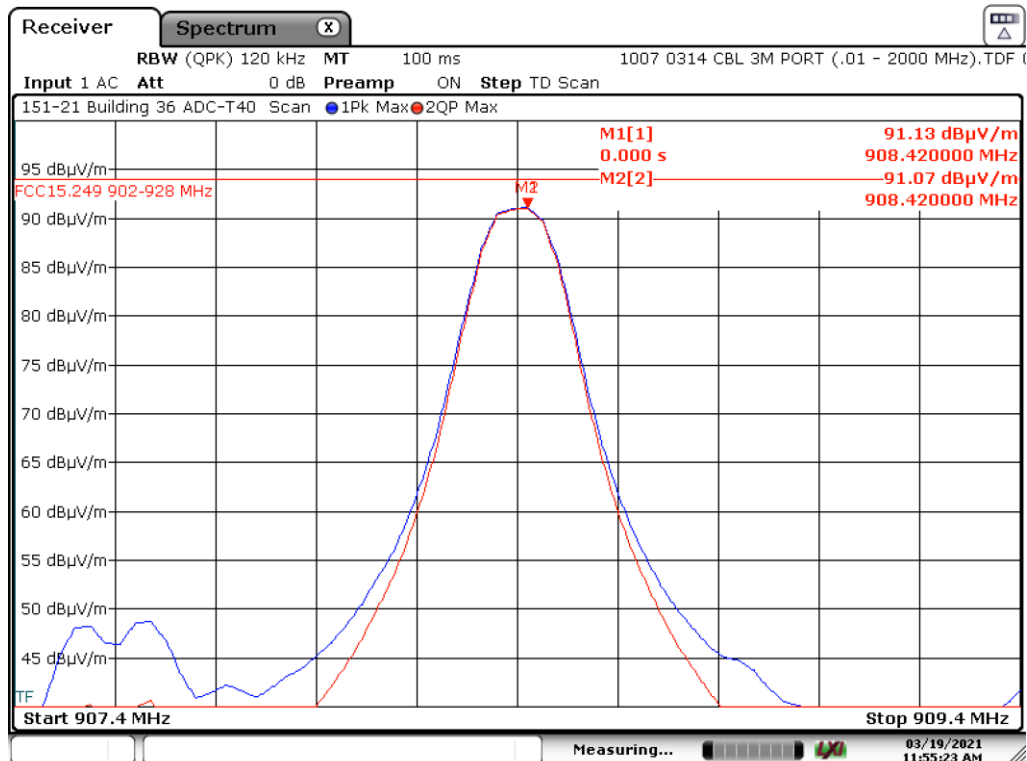

Date: 19.MAR.2021 11:55:23

6. Measurement Data (continued)

6.2. Radiated Field Strength of Fundamental (15.249, Section (a), (c), ISED RSS-210 B.10)

6.2.2. Radiated Field Strength of Fundamental, 916 MHz (Worst case)

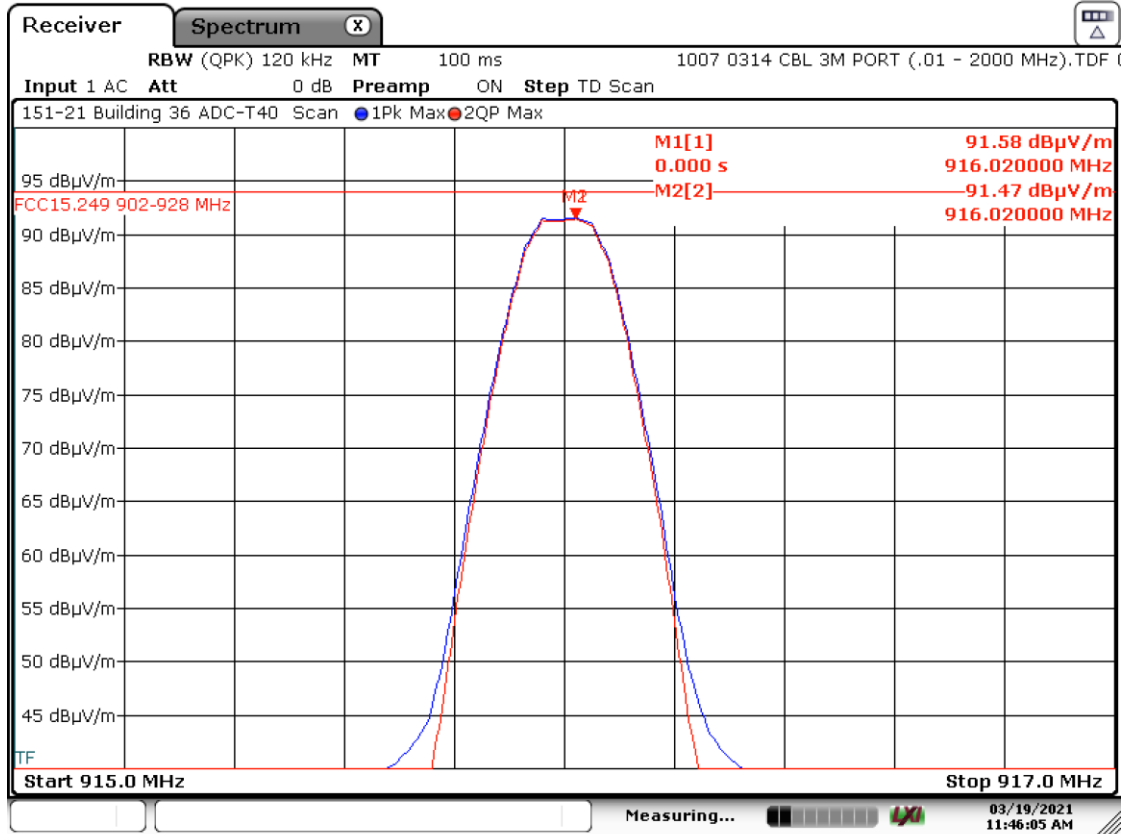

Date: 19.MAR.2021 11:46:05

6. Measurement Data (continued)

6.3. Radiated Field Strength of Harmonics (15.249, Section (a), ISED RSS-210 A.1.4 (d))

Requirement: The 3 meter field strength of the harmonic emissions from intentional radiators operated within the 2400 to 2483.5 MHz frequency bands shall comply with the following: 500 microvolts/meter (54 dB μ V/m), average mode measurement. Peak field strength may not be greater than 20 dB above the average limit (74 dB μ V/m).

Test Results : Compliant

Notes: All correction factors are included in the field strength values. The tabled values represent the worst case antenna polarity and orthogonal position of the DUT.

6.3.1. Fundamental Frequency = 908.4 MHz

Freq. (MHz)	Field Strength (dB μ V/m)		Limit (dB μ V/m)		Margin (dB μ V/m)		Antenna Polarity (H/V)	Result
	Peak	Average	Peak	Average	Peak	Average		
1816.80	42.80	30.75	74.00	54.00	-31.20	-23.25	H	Compliant
2725.20	45.93	33.45	74.00	54.00	-28.07	-20.55	V	Compliant
3633.60	49.02	35.92	74.00	54.00	-24.98	-18.08	V	Compliant
4542.00	49.46	37.06	74.00	54.00	-24.54	-16.94	V	Compliant
5450.40	48.85	37.38	74.00	54.00	-25.15	-16.62	V	Compliant
6358.80	51.09	38.88	74.00	54.00	-22.91	-15.12	V	Compliant
7267.20	53.15	40.55	74.00	54.00	-20.85	-13.45	V	Compliant
8175.60	54.97	42.75	74.00	54.00	-19.03	-11.25	V	Compliant
9084.00	53.71	40.26	74.00	54.00	-20.29	-13.74	V	Compliant

6.3.2. Fundamental Frequency = 916 MHz

Freq. (MHz)	Field Strength (dB μ V/m)		Limit (dB μ V/m)		Margin (dB μ V/m)		Antenna Polarity (H/V)	Result
	Peak	Average	Peak	Average	Peak	Average		
1832.00	54.97	42.75	74.00	54.00	-19.03	-11.25	H	Compliant
2748.00	53.71	40.26	74.00	54.00	-20.29	-13.74	H	Compliant
3664.00	48.41	36.40	74.00	54.00	-25.59	-17.60	H	Compliant
4580.00	50.08	37.59	74.00	54.00	-23.92	-16.41	H	Compliant
5496.00	50.17	37.97	74.00	54.00	-23.83	-16.03	H	Compliant
6412.00	51.77	39.42	74.00	54.00	-22.23	-14.58	H	Compliant
7328.00	53.60	41.33	74.00	54.00	-20.40	-12.67	H	Compliant
8244.00	56.03	43.47	74.00	54.00	-17.97	-10.53	H	Compliant
9160.00	46.83	34.24	74.00	54.00	-27.17	-19.76	H	Compliant

6. Measurement Data (continued)

6.4. Band Edge Measurements (15.249, Section (d), ISED RSS-210 A.1.4 (d))

Requirement: Emissions radiated outside of the specified frequency band of 902 to 928 MHz, except for harmonics, shall be attenuated by at least 50 dB below the level of the fundamental or to the general radiated emission limits in Section 15.209, whichever is the lesser attenuation.

Test Note: The upper and lower band edge peak mode measurements meet the FCC Part 15, Section 15.209 quasi-peak requirement of 46 dBµV/m.

6.4.1. Band Edge

6.4.1.1. Modulated Carrier

Freq. (MHz)	Amplitude (dBµV/m)		Band Edge (dBµV/m)				Limit (dBµV/m)	Margin (dBµV/m)	Result
	Peak	Quasi Peak	Band Edge	Freq MHz	Peak	Quasi Peak	15.209 QP	15.209 QP	
908.4	91.13	91.07	Lower	902		22	46.00	-24	Compliant
			Upper	928		22	46.00	-24	Compliant
916.0	91.58	91.47	Lower	902		22	46.00	-24	Compliant
			Upper	928		22	46.00	-24	Compliant

6. Measurement Data (continued)

6.4. Band Edge Measurements (15.249, Section (d), ISED RSS-210 A.1.4 (d))

6.4.3. 908.4 MHz

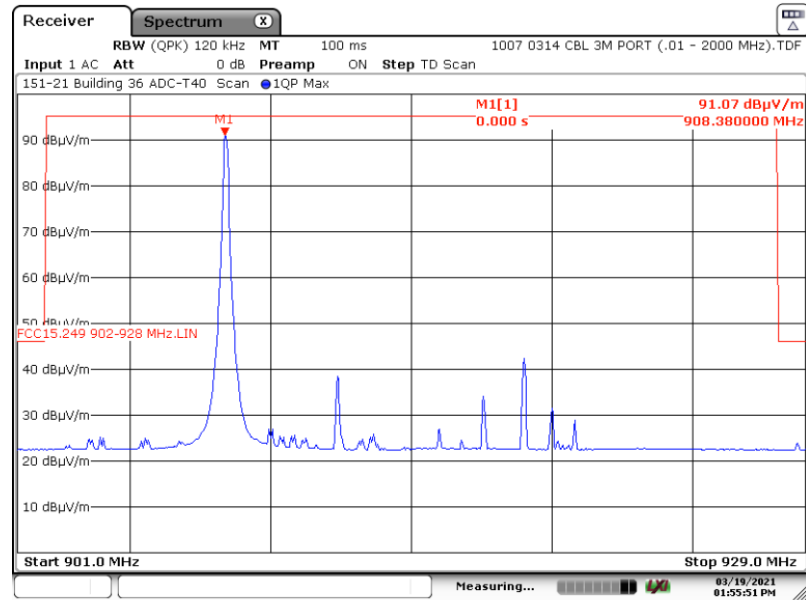

Date: 19.MAR.2021 13:55:51

6.4.4. 916 MHz

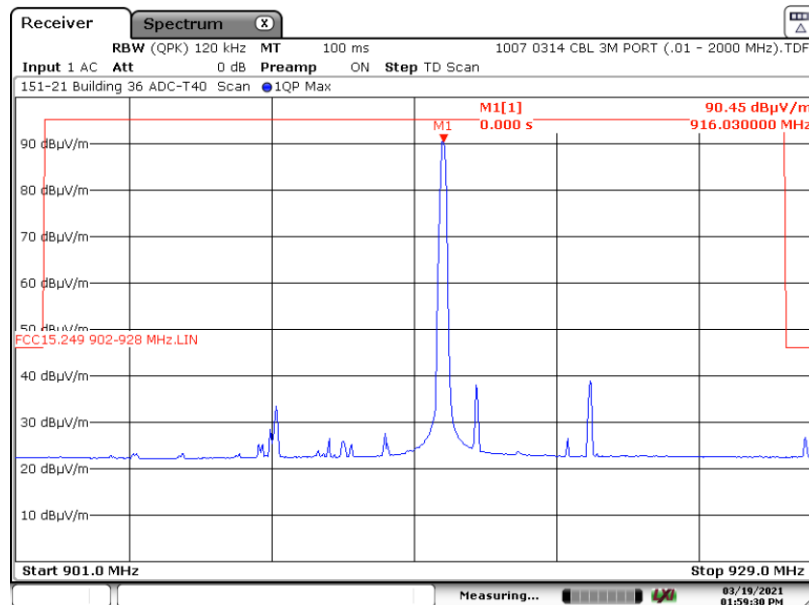

Date: 19.MAR.2021 13:59:31

6. Measurement Data (continued)

6.5. Spurious Radiated Emissions, 32 kHz to EUT 10th Harmonic (15.249, Section (d)), ISED RSS-GEN, Issue 5

Requirement: Emissions radiated outside of the specified frequency bands, except for harmonics, shall be attenuated by at least 50 dB below the level of the fundamental or to the general radiated emission limits in Section 15.209, whichever is the lesser attenuation.

Test Notes: Spurious emissions screen captures are located in appendices A and B.

The lowest frequency generated by the device under test is 32.768 kHz.

6.5.1. Regulatory Limit: FCC Part 209, Quasi-Peak & Average

Frequency Range (MHz)	Distance (Meters)	Limit (dB μ V/m)
0.009 to 0.490	3	128.5 to 93.8
0.490 to 1.705	3	73.8 to 63
1.705 to 30	3	69.5
30 to 88	3	40.0
88 to 216	3	43.5
216 to 960	3	46.0
Above 960	3	54.0

Sample Calculation: Final Result (dB μ V/m) = Measurement Value (dB μ V) + Antenna Factor (dB/m) + Cable Loss (dB) – Pre-amplifier Gain (dB) Internal or External.

Note: All correction factors are loaded into the measurement instrument prior to testing to determine the final result.

6. Measurement Data (continued)

6.6 Occupied Bandwidth (ANSI C63.10, Section 6.9.1 & ISED RSS-GEN, Issue 4)

Requirement: The occupied bandwidth measurements on an intentional radiator shall be made in accordance with the requirements outlined in ANSI C63.10-2013, Section 6.9.1. If no bandwidth requirement is specified by the procuring or regulatory agency, the bandwidth will be measured at -20 dB with respect to the reference level.

Test Notes: The span range for the SA display shall be between two times and five times the OBW. The nominal IF filter bandwidth (3 dB RBW) should be approximately 1% to 5% of the OBW, unless otherwise specified, depending on the applicable requirement. The dynamic range of the SA at the selected RBW shall be more than 10 dB below the target “dB down” (attenuation) requirement, i.e., if the requirement calls for measuring the -20 dB OBW, the SA noise floor at the selected RBW shall be at least 30 dB below the largest measured value on the display.

Frequency (MHz)	-20 dB Bandwidth (kHz)
908.4	92.91
916.0	121.88

6.6.1. Occupied (-20 dB) Bandwidth, Fundamental Frequency = 908.4 MHz

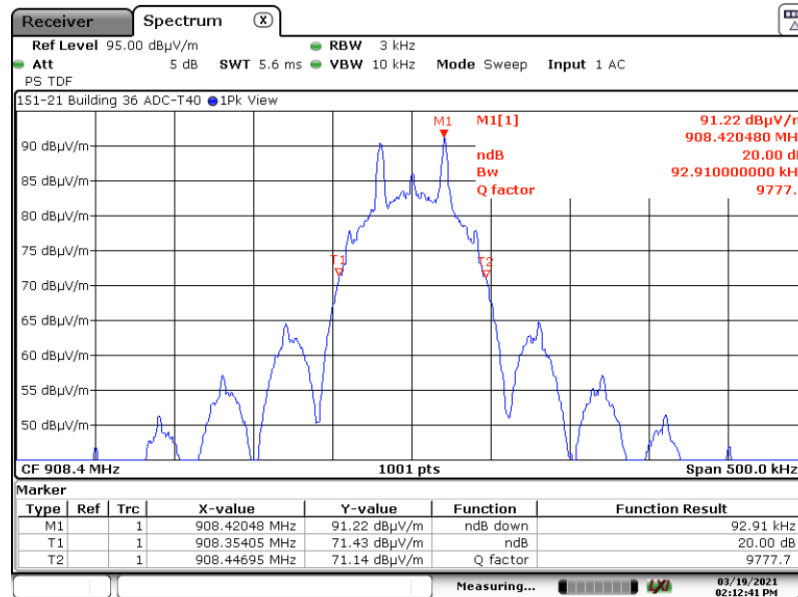

Date: 19.MAR.2021 14:12:42

6. Measurement Data (continued)

6.6 Occupied Bandwidth (ANSI C63.10, Section 6.9.1 & ISED RSS-GEN, Issue 4)

6.6.2. Occupied (-20 dB) Bandwidth, Fundamental Frequency = 916.0 MHz

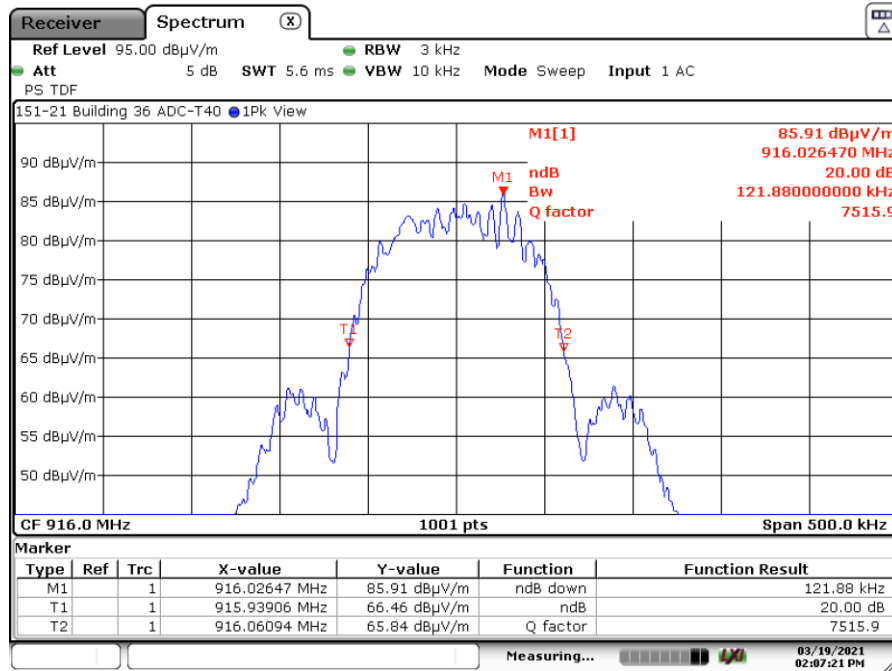

Date: 19.MAR.2021 14:07:21

6. Measurement Data (continued)

6.7 99% Emission Bandwidth (ISED RSS-GEN)

Requirement: When an occupied bandwidth value is not specified in the applicable RSS, the transmitted signal bandwidth to be reported is to be its 99% emission bandwidth, as calculated or measured.

Test Notes: The transmitter shall be operated at its maximum carrier power measured under normal test conditions. The span of the analyzer shall be set to capture all products of the modulation process, including the emission skirts. The resolution bandwidth shall be set to as close to 1% of the selected span as is possible without being below 1%. The video bandwidth shall be set to 3 times the resolution bandwidth. Video averaging is not permitted. Where practical, a sampling detector shall be used given that a peak or peak hold may produce a wider bandwidth than actual.

Frequency (MHz)	99% Power Bandwidth (kHz)
908.4	92.907
916.0	113.886

6.7.1. 99% Power Bandwidth, Fundamental Frequency = 908.4 MHz

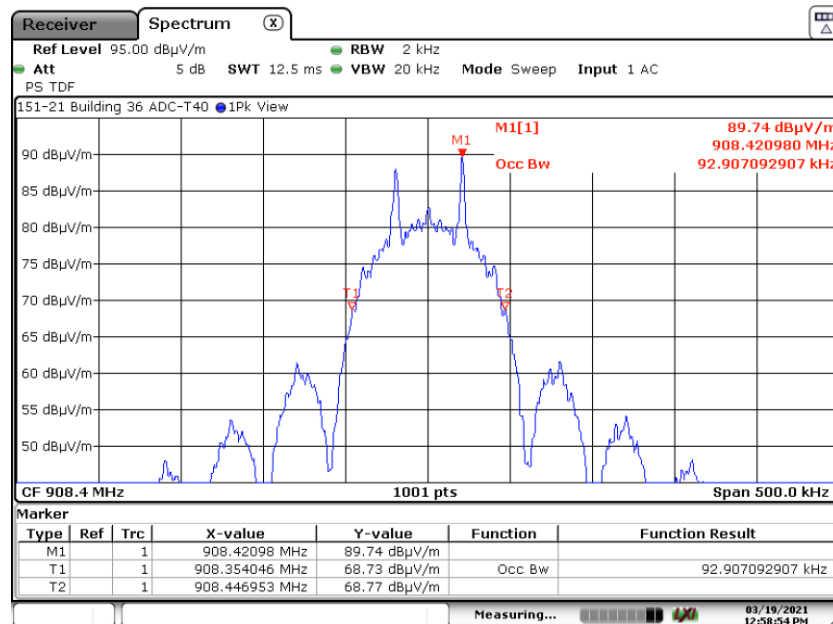

Date: 19.MAR.2021 12:58:54

6. Measurement Data (continued)

6.7 99% Emission Bandwidth (ISED RSS-GEN)

6.7.2. 99% Power Bandwidth, Fundamental Frequency = 916.0 MHz

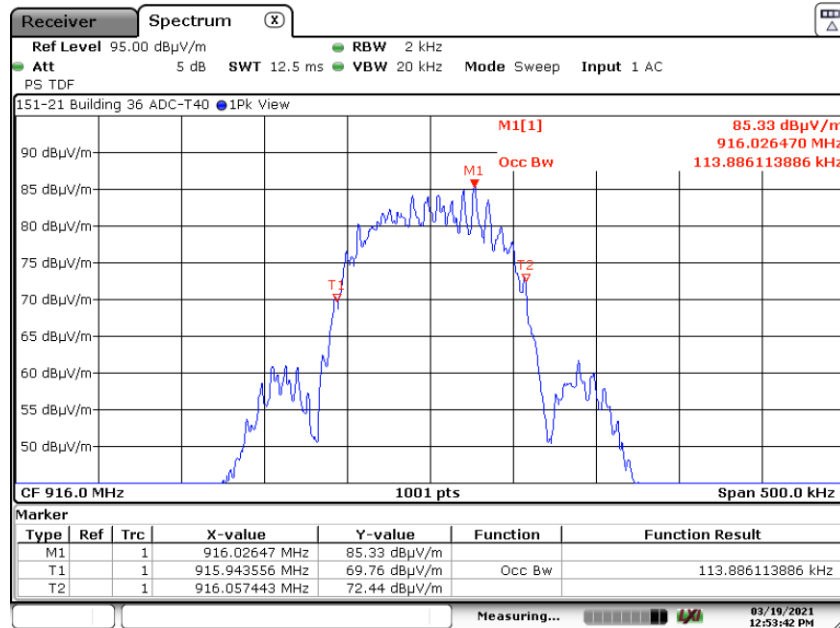

Date: 19.MAR.2021 12:53:42

6. Measurement Data (continued)

6.8. Conducted Emissions

Requirement: 15.207 With certain exceptions, an intentional radiator that is designed to be connected to the public utility (AC) power line, the radio frequency voltage that is conducted back onto the AC power line on any frequency or frequencies, within the band 150 kHz to 30 MHz, shall not exceed the limits in the following table, as measured using a 50 μ H/50 Ω line impedance stabilization network (LISN).

Frequency Range (MHz)	Limits (dB μ V)	
	Quasi-Peak	Average
0.15 to 0.50	66 to 56*	56 to 46*
0.50 to 5.0	56	46
5.0 to 30.0	60	50

* Decreases with the logarithm of the frequency.

Procedure: This test was performed in accordance with the procedure detailed in ANSI C63.10-2013, Section 6.2: Standard test method for ac power-line conducted emissions from unlicensed wireless devices.

Test Notes: The device was tested using the support equipment laptop.

Results: The device under test meets the FCC Part 15.207 test requirements.

Measurement & Equipment Setup

Test Date: 4/1/2021
 Test Engineer: Sean Defelice
 Site Temperature ($^{\circ}$ C): 22.5
 Relative Humidity (%RH): 43
 Frequency Range: 0.15 MHz to 30 MHz
 EMI Receiver IF Bandwidth: 9 kHz
 EMI Receiver Avg Bandwidth: $\geq 3 * \text{IF BW (RBW)}$
 Detector Functions: Peak, Quasi-Peak & Average

Sample Calculation: Final Result (dB μ V) = Measurement Value (dB μ V) + LISN Insertion Loss (dB) + Cable Loss (dB).

Note: All correction factors are loaded into the measurement instrument prior to testing to determine the final result.

**6. Measurement Data (continued)
Conducted Emissions Test Results**

6.8.1. 120 Volts, 60 Hz Phase

Test No.: 159-21, 120 Volts, 60 Hz Phase

FCC, Class B

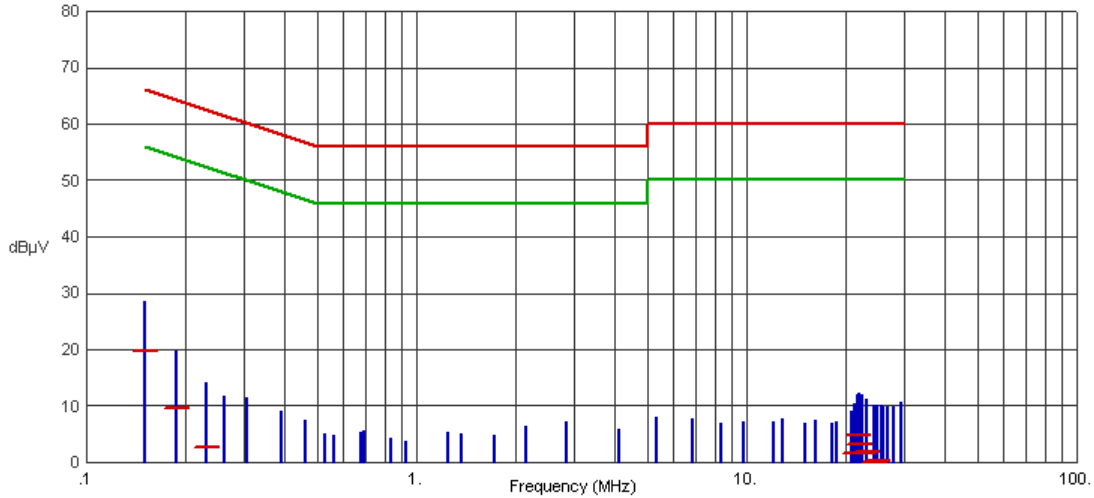

Frequency (MHz)	Pk Amp (dBµV)	QP Amp (dBµV)	QP Limit (dBµV)	QP Margin (dB)	Avg Amp (dBµV)	Avg Limit (dBµV)	Avg Margin (dB)	Comments
.1500	28.56	19.84	66.00	-46.16	-3.23	56.00	-59.23	
.1883	19.68	9.61	64.11	-54.50	-7.86	54.11	-61.97	
.2310	14.09	2.69	62.41	-59.72	-9.45	52.41	-61.86	
.2625	11.85	-1.07	61.35	-62.42	-10.20	51.35	-61.55	
.3075	11.35	-3.40	60.04	-63.44	-10.89	50.04	-60.93	
.3908	9.07	-4.59	58.05	-62.64	-11.37	48.05	-59.42	
.4628	7.54	-5.99	56.64	-62.63	-11.87	46.64	-58.51	
.5303	5.09	-6.54	56.00	-62.54	-12.02	46.00	-58.02	
.5618	4.77	-6.52	56.00	-62.52	-12.13	46.00	-58.13	
.6765	5.20	-6.68	56.00	-62.68	-12.14	46.00	-58.14	
.6968	5.50	-6.57	56.00	-62.57	-12.22	46.00	-58.22	
.8408	4.36	-6.60	56.00	-62.60	-12.01	46.00	-58.01	
.9263	3.69	-6.58	56.00	-62.58	-12.10	46.00	-58.10	
1.2480	5.28	-6.57	56.00	-62.57	-12.03	46.00	-58.03	
1.3628	5.00	-6.39	56.00	-62.39	-11.91	46.00	-57.91	
1.7250	4.87	-5.57	56.00	-61.57	-10.84	46.00	-56.84	
2.1458	6.50	-6.29	56.00	-62.29	-11.58	46.00	-57.58	
2.8365	7.20	-3.44	56.00	-59.44	-8.85	46.00	-54.85	
4.0920	5.95	-4.68	56.00	-60.68	-10.19	46.00	-56.19	
5.3475	7.94	-4.15	60.00	-64.15	-9.63	50.00	-59.63	
6.8685	7.70	-3.80	60.00	-63.80	-9.37	50.00	-59.37	
8.3873	6.95	-3.95	60.00	-63.95	-9.22	50.00	-59.22	
9.7845	7.29	-3.77	60.00	-63.77	-9.19	50.00	-59.19	
12.0593	7.32	-3.61	60.00	-63.61	-8.96	50.00	-58.96	
12.8220	7.75	-3.77	60.00	-63.77	-9.21	50.00	-59.21	
15.0765	6.83	-4.30	60.00	-64.30	-9.55	50.00	-59.55	
16.2285	7.59	-3.60	60.00	-63.60	-9.40	50.00	-59.40	
18.0758	7.00	-4.07	60.00	-64.07	-9.71	50.00	-59.71	
18.7665	7.26	-4.30	60.00	-64.30	-9.46	50.00	-59.46	
20.8208	9.07	-3.05	60.00	-63.05	-8.34	50.00	-58.34	
21.1740	10.35	1.52	60.00	-58.48	-3.68	50.00	-53.68	
21.6645	11.97	4.79	60.00	-55.21	-.09	50.00	-50.09	

6. Measurement Data (continued)
Conducted Emissions Test Results (continued)
6.8.1. 120 Volts, 60 Hz Phase (continued)

Frequency (MHz)	Pk Amp (dBµV)	QP Amp (dBµV)	QP Limit (dBµV)	QP Margin (dB)	Avg Amp (dBµV)	Avg Limit (dBµV)	Avg Margin (dB)	Comments
21.9075	12.32	3.20	60.00	-56.80	-93	50.00	-50.93	
22.4565	11.91	1.50	60.00	-58.50	-2.85	50.00	-52.85	
23.1293	11.07	1.84	60.00	-58.16	-3.25	50.00	-53.25	
24.3488	10.05	.10	60.00	-59.90	-4.85	50.00	-54.85	
24.9000	10.14	.32	60.00	-59.68	-5.64	50.00	-55.64	
25.5975	10.10	-1.39	60.00	-61.39	-6.68	50.00	-56.68	
25.8608	9.94	-1.86	60.00	-61.86	-7.23	50.00	-57.23	
26.6100	9.97	-.15	60.00	-60.15	-5.54	50.00	-55.54	
28.0140	9.88	-.85	60.00	-60.85	-6.43	50.00	-56.43	
29.4270	10.60	-.47	60.00	-60.47	-5.80	50.00	-55.80	

**6. Measurement Data (continued)
Conducted Emissions Test Results (continued)**

6.8.2. 120 Volts, 60 Hz Neutral

Test No.: 159-21, 120 Volts, 60 Hz Neutral

FCC, Class B

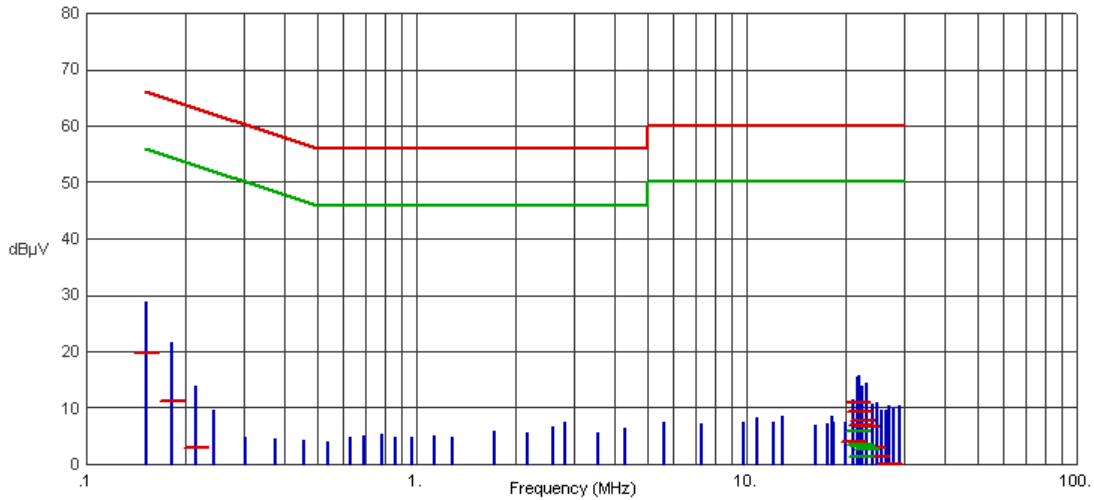

Frequency (MHz)	Pk Amp (dBµV)	QP Amp (dBµV)	QP Limit (dBµV)	QP Margin (dB)	Avg Amp (dBµV)	Avg Limit (dBµV)	Avg Margin (dB)	Comments
.1523	28.79	19.75	65.87	-46.12	-3.40	55.87	-59.27	
.1815	21.63	11.08	64.42	-53.34	-7.49	54.42	-61.91	
.2153	13.99	3.00	63.00	-60.00	-9.17	53.00	-62.17	
.2445	9.70	-2.70	61.94	-64.64	-10.18	51.94	-62.12	
.3030	4.70	-5.38	60.16	-65.54	-11.00	50.16	-61.16	
.3750	4.47	-5.98	58.39	-64.37	-11.42	48.39	-59.81	
.4538	4.15	-6.35	56.81	-63.16	-11.81	46.81	-58.62	
.5393	4.03	-6.68	56.00	-62.68	-11.83	46.00	-57.83	
.6315	4.82	-6.64	56.00	-62.64	-12.03	46.00	-58.03	
.6923	5.10	-6.67	56.00	-62.67	-11.92	46.00	-57.92	
.7868	5.43	-6.46	56.00	-62.46	-11.90	46.00	-57.90	
.8610	4.70	-5.48	56.00	-61.48	-10.70	46.00	-56.70	
.9668	4.85	-6.34	56.00	-62.34	-11.57	46.00	-57.57	
1.1378	5.02	-6.07	56.00	-62.07	-11.63	46.00	-57.63	
1.2885	4.71	-6.12	56.00	-62.12	-11.44	46.00	-57.44	
1.7250	5.94	-4.54	56.00	-60.54	-9.88	46.00	-55.88	
2.1593	5.62	-5.55	56.00	-61.55	-10.94	46.00	-56.94	
2.5868	6.73	-3.03	56.00	-59.03	-8.62	46.00	-54.62	
2.8185	7.36	-2.40	56.00	-58.40	-7.80	46.00	-53.80	
3.5385	5.64	-4.93	56.00	-60.93	-10.42	46.00	-56.42	
4.2990	6.53	-4.69	56.00	-60.69	-9.96	46.00	-55.96	
5.6018	7.54	-2.63	60.00	-62.63	-8.09	50.00	-58.09	
7.3185	7.21	-3.75	60.00	-63.75	-9.02	50.00	-59.02	
9.7418	7.34	-3.64	60.00	-63.64	-8.98	50.00	-58.98	
10.7903	8.36	-2.42	60.00	-62.42	-8.35	50.00	-58.35	
12.0840	7.37	-2.65	60.00	-62.65	-8.27	50.00	-58.27	
12.7995	8.51	-1.06	60.00	-61.06	-6.97	50.00	-56.97	
16.1498	6.96	-3.90	60.00	-63.90	-9.40	50.00	-59.40	
17.6865	7.28	-3.80	60.00	-63.80	-9.34	50.00	-59.34	
18.2400	8.42	-2.76	60.00	-62.76	-8.12	50.00	-58.12	
18.3615	7.39	-3.13	60.00	-63.13	-8.58	50.00	-58.58	

**6. Measurement Data (continued)
Conducted Emissions Test Results (continued)**

6.8.2. 120 Volts, 60 Hz Neutral (continued)

Frequency (MHz)	Pk Amp (dB μ V)	QP Amp (dB μ V)	QP Limit (dB μ V)	QP Margin (dB)	Avg Amp (dB μ V)	Avg Limit (dB μ V)	Avg Margin (dB)	Comments
20.0490	7.46	-3.00	60.00	-63.00	-8.62	50.00	-58.62	
21.1133	11.38	4.01	60.00	-55.99	-3.05	50.00	-53.05	
21.6645	15.42	10.94	60.00	-49.06	5.96	50.00	-44.04	
21.9075	15.75	9.21	60.00	-50.79	3.57	50.00	-46.43	
22.2135	13.84	7.04	60.00	-52.96	1.42	50.00	-48.58	
22.4565	13.75	7.74	60.00	-52.26	3.07	50.00	-46.93	
23.1293	14.48	6.74	60.00	-53.26	2.57	50.00	-47.43	
24.0450	10.76	3.05	60.00	-56.95	-3.17	50.00	-53.17	
24.9608	10.94	1.46	60.00	-58.54	-3.74	50.00	-53.74	
25.6043	9.56	-1.43	60.00	-61.43	-6.88	50.00	-56.88	
26.5448	9.67	-0.74	60.00	-60.74	-6.46	50.00	-56.46	
27.1568	10.33	.01	60.00	-59.99	-5.86	50.00	-55.86	
27.9960	9.94	-0.78	60.00	-60.78	-6.51	50.00	-56.51	
29.0580	10.51	-0.22	60.00	-60.22	-5.93	50.00	-55.93	

6. Measurement Data (continued)

6.9. Public Exposure to Radio Frequency Energy Levels (1.1307 (b) (1)) RSS-GEN, ISSUE 5, Section 3.4, RSS 102)

6.9.1. 1.1307 (b) (1) Public Exposure

Requirement: Systems operating under the provisions of this section shall be operated in a manner that ensures that the public is not exposed to radio frequency energy levels in excess of the Commission's guidelines.

Frequency (MHz)	MPE Distance (cm)	DUT Output Power (dBm)	DUT Antenna Gain (dBi)	Power Density		Limit (mW/cm ²)	Result
				(mW/cm ²)	(W/m ²)		
				(1)	(2)		
908.396	20	-4.13	0	0.000076865	0.00076865	0.6055973	Compliant
916.000	20	-3.73	0	0.000084281	0.00084281	0.6106667	Compliant

$$PD = \frac{OP + AG}{(4 \times \pi \times d^2)}$$

- PD = Power Density (mW/cm²)
- OP = DUT Output Power (dBm)
- AG = DUT Antenna Gain (dBi)
- d = MPE Distance (cm)

1. Reference CFR 2.1091: For purposes of this section, a mobile device is defined as a transmitting device designed to be used in other than fixed locations and to generally be used in such a way that a separation distance of at least 20 centimeters is normally maintained between the transmitter's radiating structure(s) and the body of the user or nearby persons.
2. Table 6.2 of this test report. Converted from field strength measurements.
3. Factored into field strength measurement.
4. Power density is calculated from field strength measurement and antenna gain.
5. Reference CFR 1.1310, Table 1: Limits for Maximum Permissible Exposure (MPE), Section (B): Limits for General Population/Uncontrolled Exposure. Limit = f/1500, where f is in MHz.

Results: Passed - The device under test meets the exclusion requirement detailed for a device with a separation distance of 20 cm.

6. Measurement Data (continued)

6.9. Public Exposure to Radio Frequency Energy Levels (15.247(i) (1.1307 (b)(1)) RSS-GEN, ISSUE 5, section 3.4, RSS 102)

6.9.2. RSS-102 Issue 5 Requirements

Requirement: Requirement: RF exposure evaluation is required if the separation distance between the user and/or bystander and the device's radiating element is greater than 20 cm, except when the device operates as follows:

at or above 300 MHz and below 6 GHz and the source-based, time-averaged maximum e.i.r.p. of the device is equal to or less than $1.31 \times 10^{-2} \times f^{0.6834}$ W (adjusted for tune-up tolerance), where f is in MHz.

Results: Compliant

Frequency	Separation Distance	Maximum Power ¹		RSS-102 Exemption Limit ²	Result
		(mW)	(Watts)	(Watts)	
908.40	≥ 20	0.39	0.00039	1.38	Compliant
916.00	≥ 20	0.42	0.00042	1.38	Compliant

¹ Reference Section 6.2 of this report.

² Reference RSS-102, § 2.5.2 Exemption Limits for Routine Evaluation – RF Exposure Evaluation for distances greater than 20 cm.

The following formula was used to determine the exemption limit (W):

$$1.31 \times 10^{-2} \times f^{0.6834} \quad (f = \text{frequency (MHz)})$$

7. Test Setup Photographs

7.1 Radiated Spurious Emissions 30 kHz to 30 MHz, Front View



7. Test Setup Photographs

7.2 Radiated Spurious Emissions < 30 MHz, Rear View



7. Test Setup Photographs

7.3 Radiated Field Strength and Spurious Emissions, 30 MHz to 1 GHz, Rear View



7. Test Setup Photographs

7.4. Radiated Harmonics and Spurious Emissions >1 GHz, Front View



7. Test Setup Photographs

7.5. Radiated Harmonics and Spurious Emissions >1 GHz, Rear View



7. Test Setup Photographs

7.6. Conducted Emissions, Front View



7. Test Setup Photographs

7.7. Conducted Emissions, Rear View



8. Test Site Description

Compliance Worldwide is located at 357 Main Street in Sandown, New Hampshire. The test sites at Compliance Worldwide are used for conducted and radiated emissions testing in accordance with the Federal Communications Commission (FCC) and Innovation Science and Economic Development Canada (ISED) standards. Through our American Association for Laboratory Accreditation (A2LA) ISO Guide 17025 Accreditation our test sites are designated with the FCC (designation number **US1091**), Industry Canada (file number **IC 3023A-1**) and VCCI (Member number 3168) under registration number A-0274.

Compliance Worldwide is also designated as a Phase 1 CAB under APEC-MRA (US0132) for Australia/New Zealand AS/NZS CISPR 22, Chinese-Taipei (Taiwan) BSMI CNS 13438 and Korea (RRA) KN 11, KN 13, KN 14-1, KN 22, KN 32, KN 61000-6-3, KN 61000-6-4.

The radiated emissions test site is a 3 and 10 meter enclosed open area test site (OATS). Personnel, support equipment and test equipment are located in the basement beneath the OATS ground plane.

The conducted emissions site is part of a 16' x 20' x 12' ferrite tile chamber and uses one of the walls for the vertical ground plane required by EN 55022. A second conducted emissions site is also located in the basement of the OATS site with a 2.3 x 2.5 meter ground plane and a 2.4 x 2.4 meter vertical wall.

The radiated emissions test site for measurements above 1GHz is a 3 Meter open area test site (OATS) with a 3.6 by 3.6 meter anechoic absorber floor patch to achieve a quasi-free space measurement environment per ANSI C63.4/C63.10 and CISPR 16-1-4 standards.

The sites are designed to test products or systems 1.5 meters W x 1.5 meters L x 2.0 meters H, floor standing or table top.

Appendix A

Spurious Radiated Emissions, 30 kHz to EUT 10th Harmonic (15.249, Section (d)), ISED RSS-GEN, Issue 5 (continued)

A.1. Spurious Radiated Emissions (30 kHz to 150 kHz), Fundamental = 908.4 MHz

A.1.1. Measurement Results – Parallel Antenna

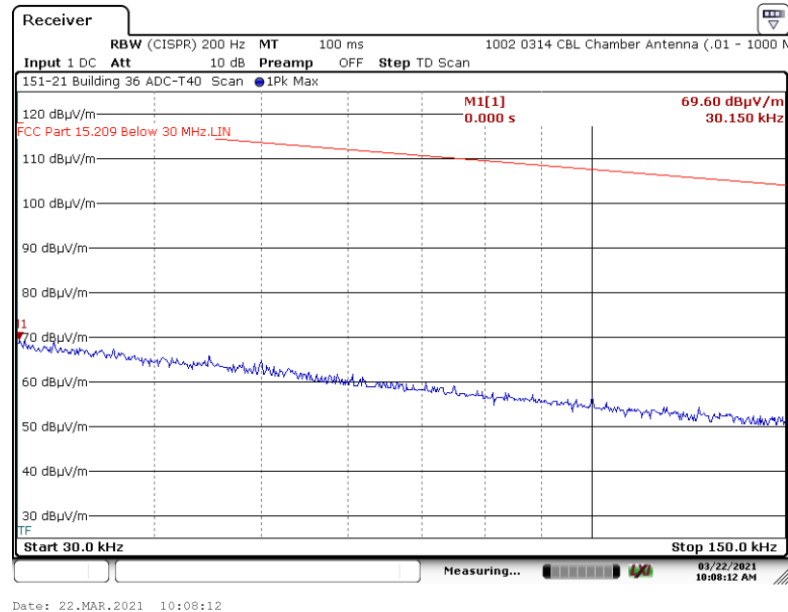

A.1.2. Measurement Results – Perpendicular Antenna

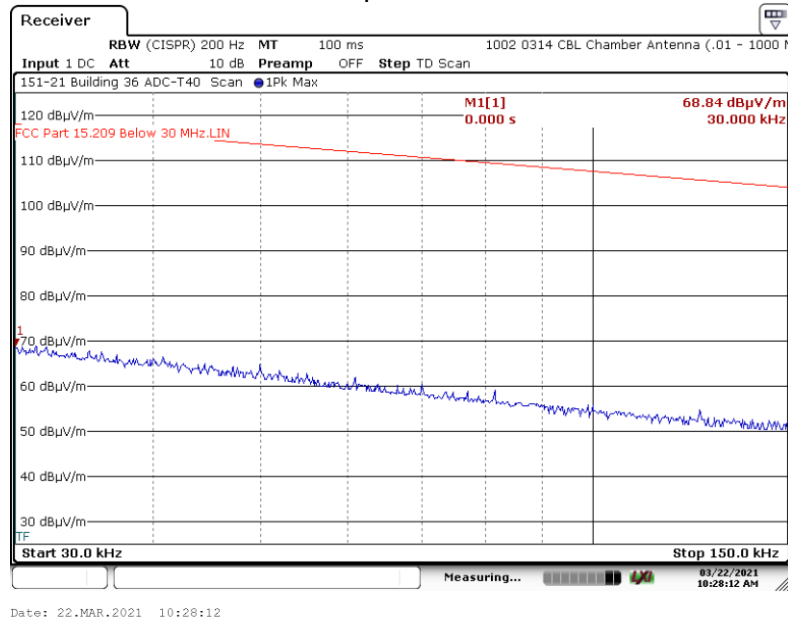

Appendix A (continued)

Spurious Radiated Emissions, 30 kHz to EUT 10th Harmonic (15.249, Section (d)),
ISED RSS-GEN, Issue 5 (continued)

A.1. Spurious Radiated Emissions (30 kHz to 150 kHz), Fundamental Freq. = 908.4 MHz

A.1.3. Measurement Results – Ground Parallel Antenna

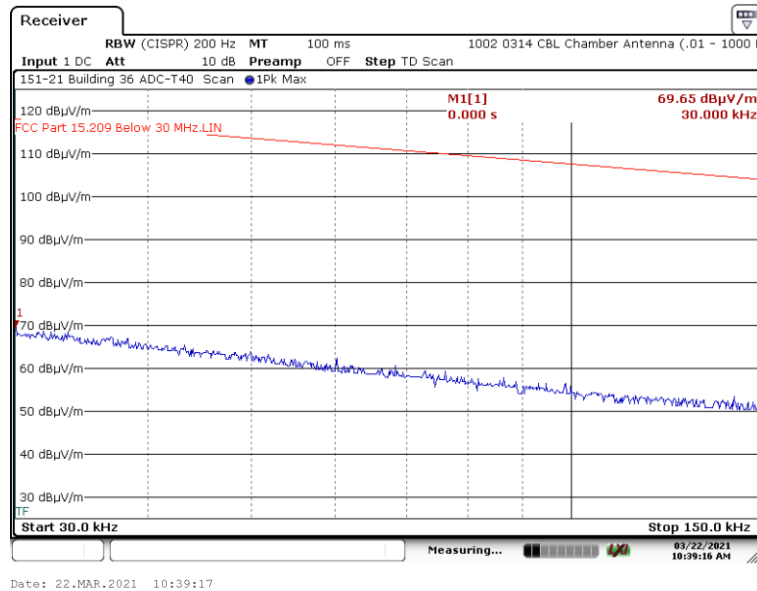

A.2. Spurious Radiated Emissions (150 kHz to 30 MHz), Fundamental = 908.4 MHz

A.2.1. Measurement Results – Parallel Antenna

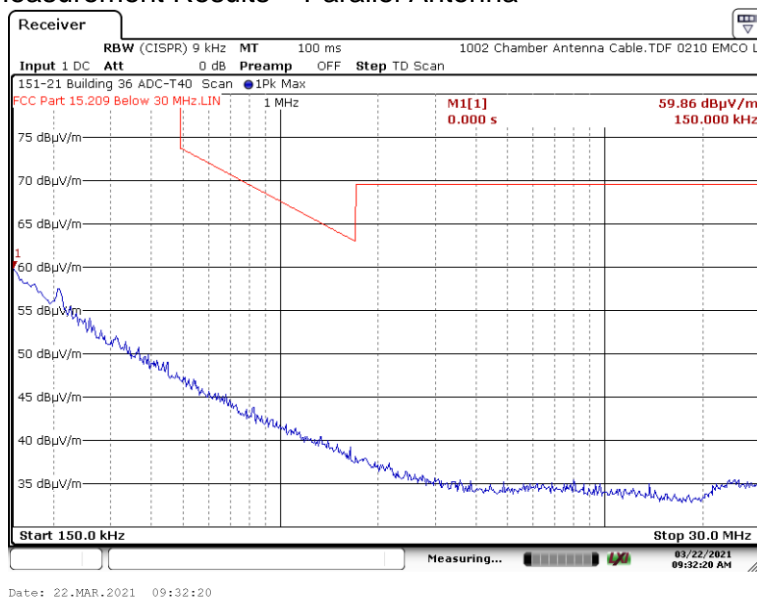

Appendix A (continued)

Spurious Radiated Emissions, 30 kHz to EUT 10th Harmonic (15.249, Section (d)),
ISED RSS-GEN, Issue 5 (continued)

A.2. Spurious Radiated Emissions (150 kHz to 30 MHz), Fundamental = 908.4 MHz

A.2.2. Measurement Results – Perpendicular Antenna

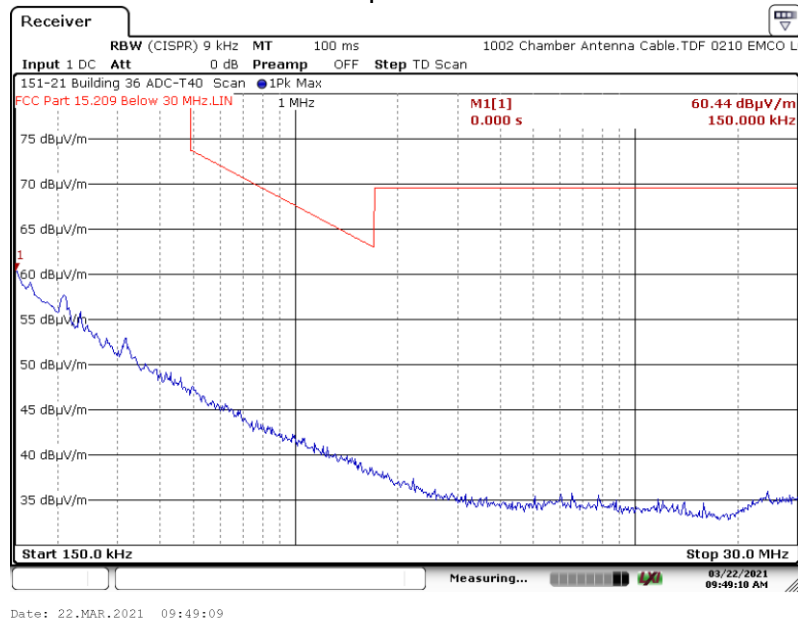

A.2.3. Measurement Results – Ground Parallel Antenna

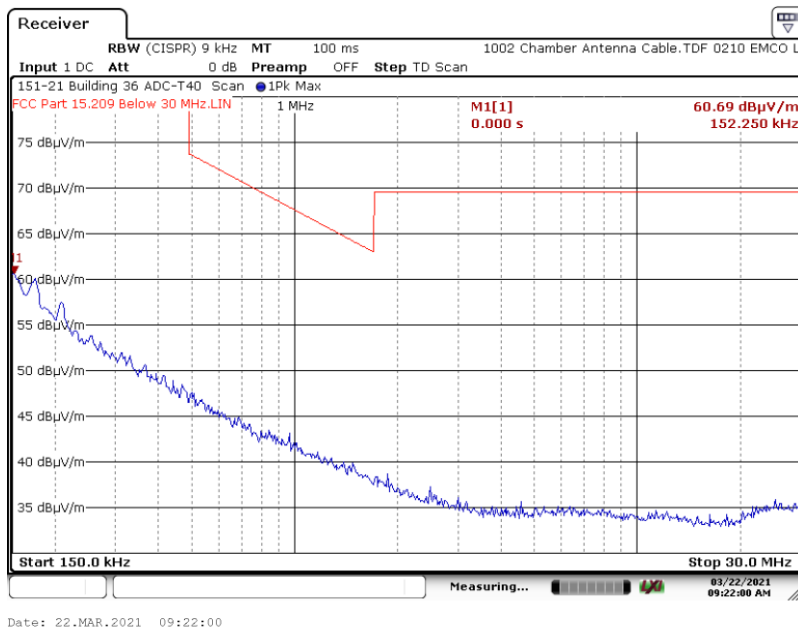

Appendix A (continued)

Spurious Radiated Emissions, 30 kHz to EUT 10th Harmonic (15.249, Section (d)),
ISED RSS-GEN, Issue 5 (continued)

A.3. Spurious Radiated Emissions (30 MHz to 1 GHz), Fundamental = 908.4 MHz

A.3.1. Measurement Results – Horizontal Antenna

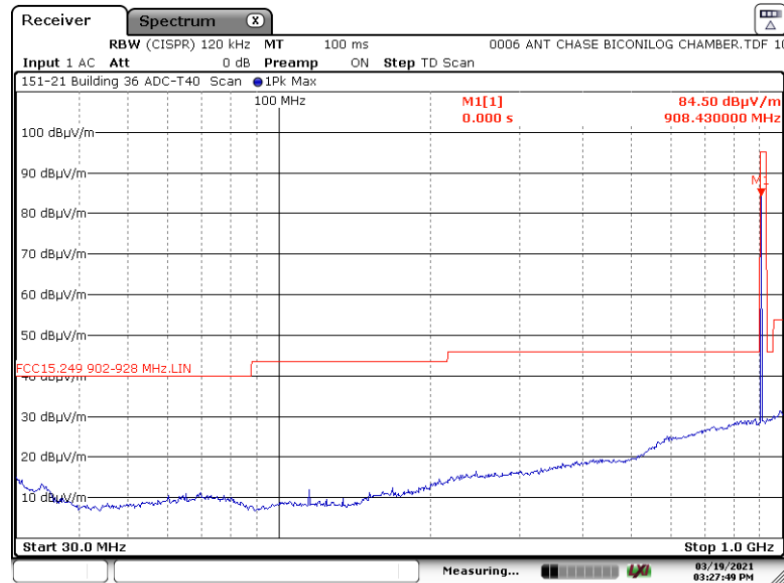

Date: 19 MAR 2021 15:27:48

A.3.2. Measurement Results – Vertical Antenna

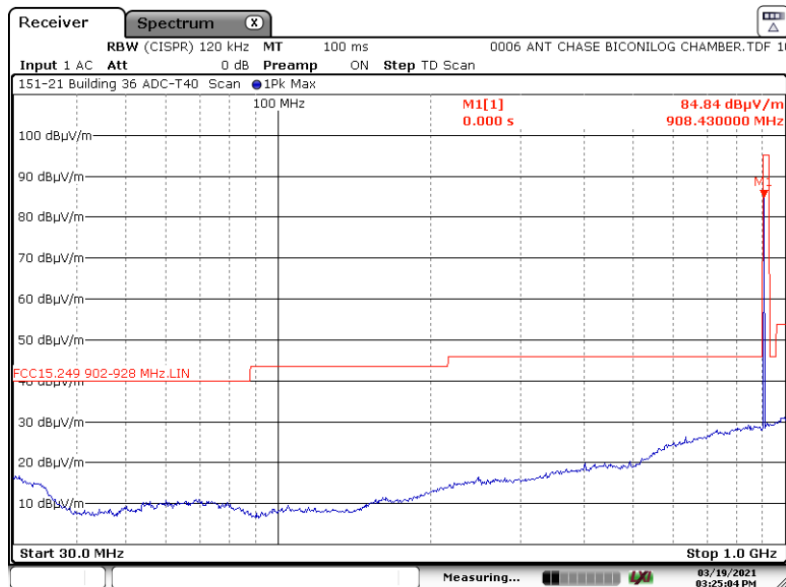

Date: 19 MAR 2021 15:25:05

Appendix A (continued)

Spurious Radiated Emissions, 30 kHz to EUT 10th Harmonic (15.249, Section (d)),
ISED RSS-GEN, Issue 5 (continued)

A.4. Spurious Radiated Emissions (1 GHz to 9.4 GHz), Fundamental = 908.4 MHz

A.4.1. Measurement Results – Horizontal Antenna

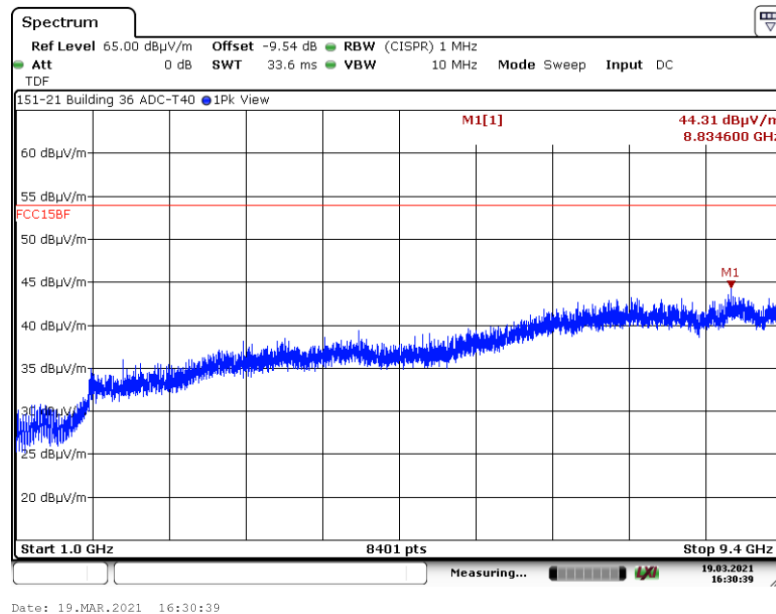

A.4.2. Measurement Results – Vertical Antenna

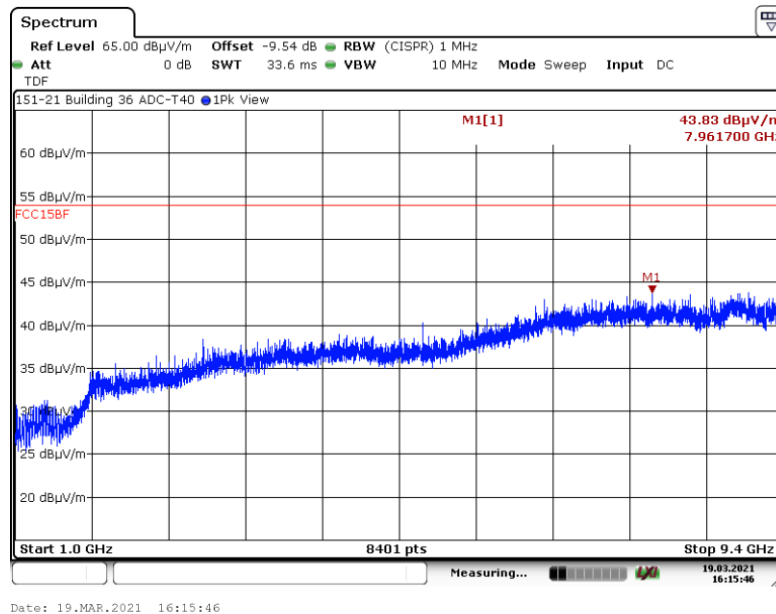

Appendix B

Spurious Radiated Emissions, 30 kHz to EUT 10th Harmonic (15.249, Section (d)), ISED RSS-GEN, Issue 5 (continued)

B.1. Spurious Radiated Emissions (30 kHz to 150 kHz), Fundamental = 916.0 MHz

B.1.1. Measurement Results – Parallel Antenna

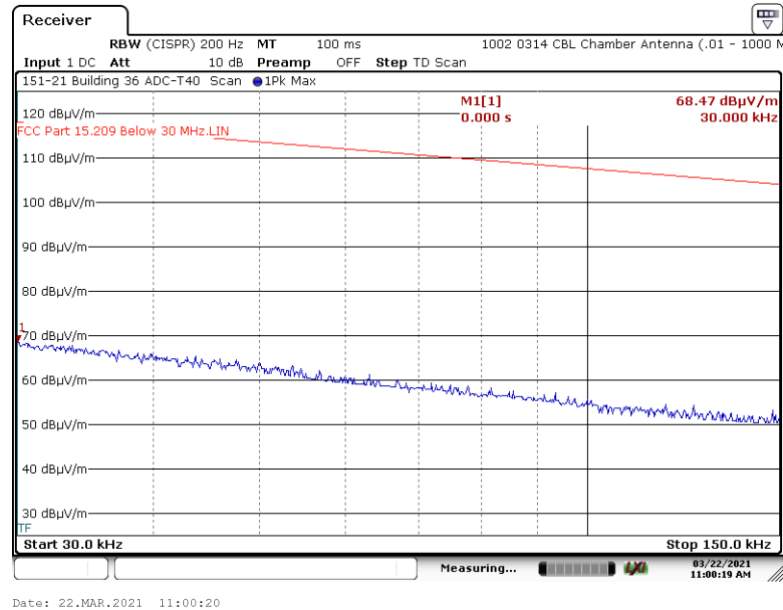

B.1.2. Measurement Results – Perpendicular Antenna

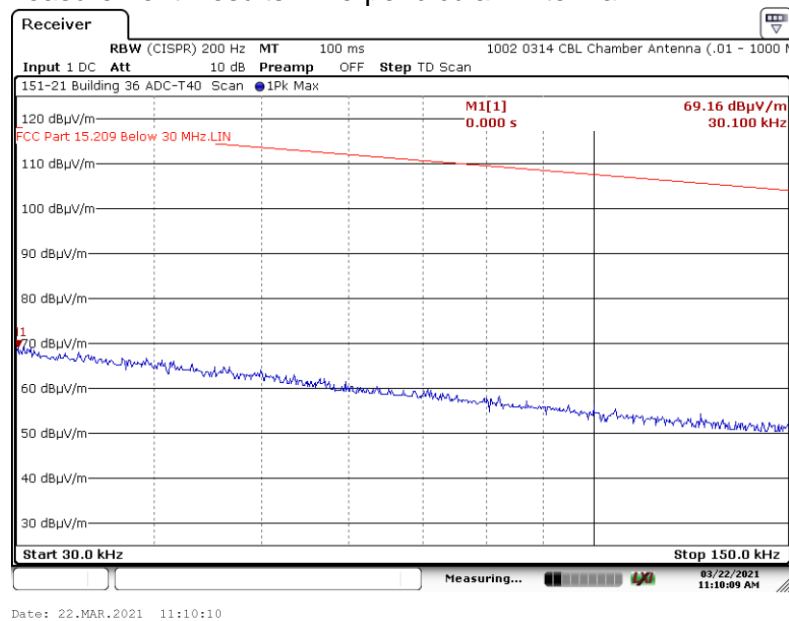

Appendix B (continued)

Spurious Radiated Emissions, 30 kHz to EUT 10th Harmonic (15.249, Section (d)),
ISED RSS-GEN, Issue 5 (continued)

B.1. Spurious Radiated Emissions (30 kHz to 150 kHz), Fundamental Freq. = 916.0 MHz

B.1.3. Measurement Results – Ground Parallel Antenna

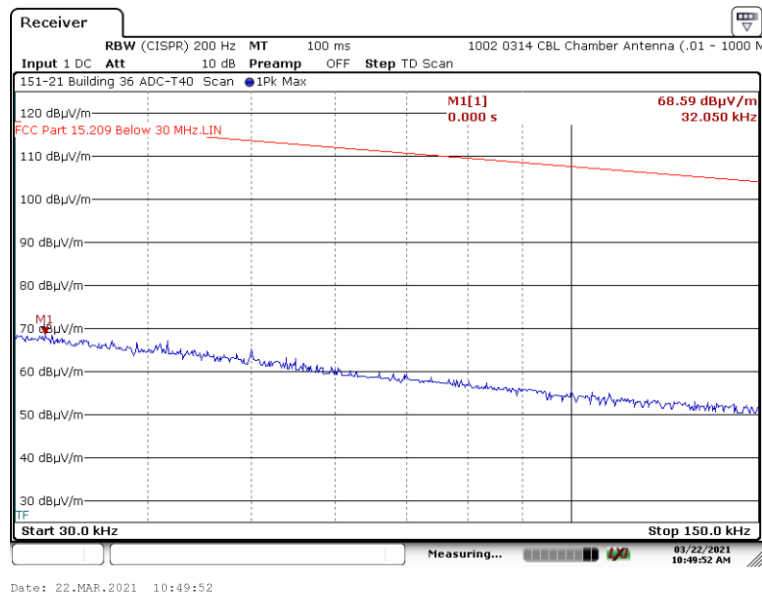

B.2. Spurious Radiated Emissions (150 kHz to 30 MHz), Fundamental = 916.0 MHz

B.2.1. Measurement Results – Parallel Antenna

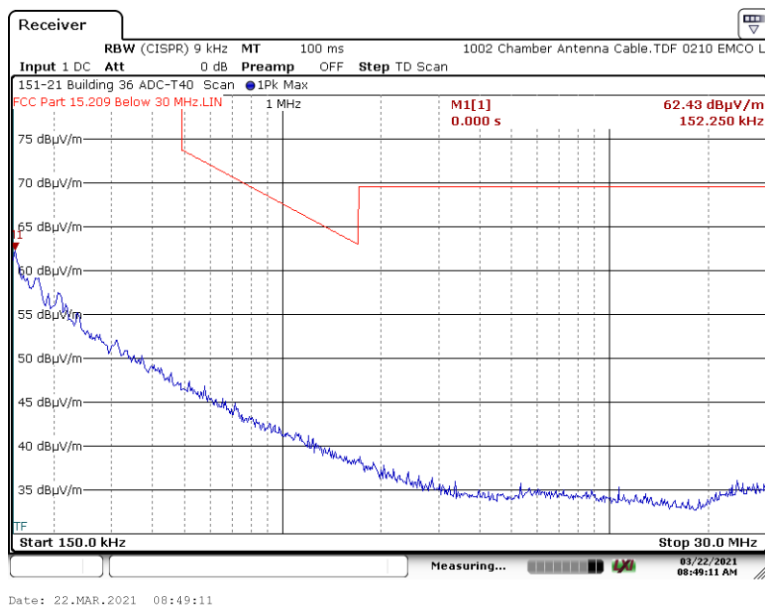

Appendix B (continued)

Spurious Radiated Emissions, 30 kHz to EUT 10th Harmonic (15.249, Section (d)),
ISED RSS-GEN, Issue 5 (continued)

B.2. Spurious Radiated Emissions (150 kHz to 30 MHz), Fundamental = 916.0 MHz

B.2.2. Measurement Results – Perpendicular Antenna

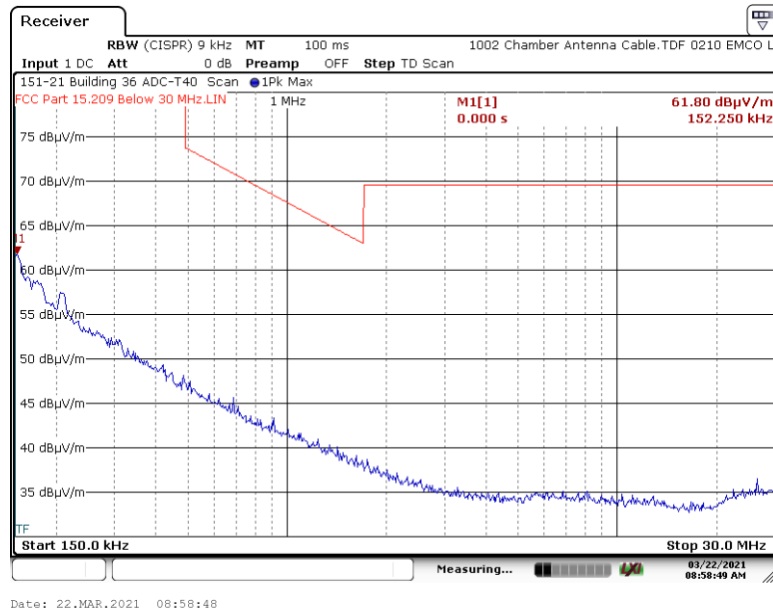

B.2.3. Measurement Results – Ground Parallel Antenna

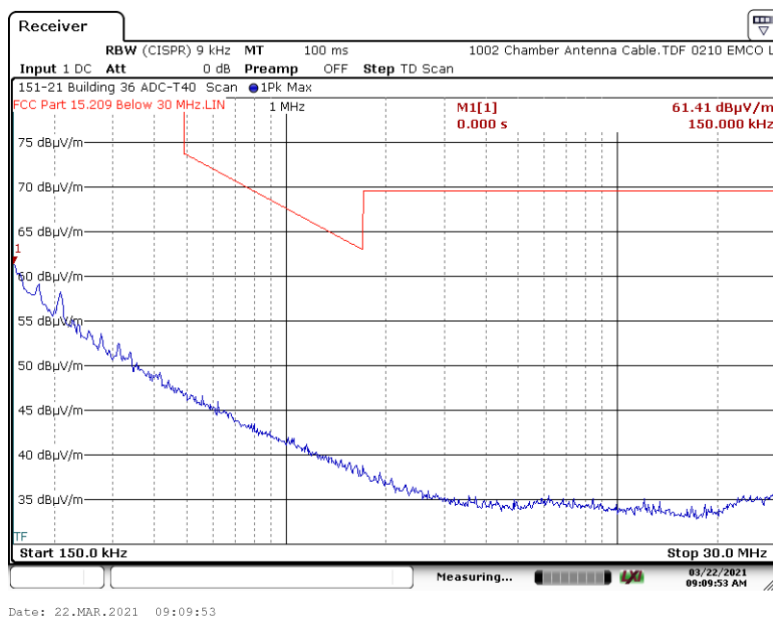

Appendix B (continued)

Spurious Radiated Emissions, 30 kHz to EUT 10th Harmonic (15.249, Section (d)),
ISED RSS-GEN, Issue 5 (continued)

B.3. Spurious Radiated Emissions (30 MHz to 1 GHz), Fundamental = 916.0 MHz

B.3.1. Measurement Results – Horizontal Antenna

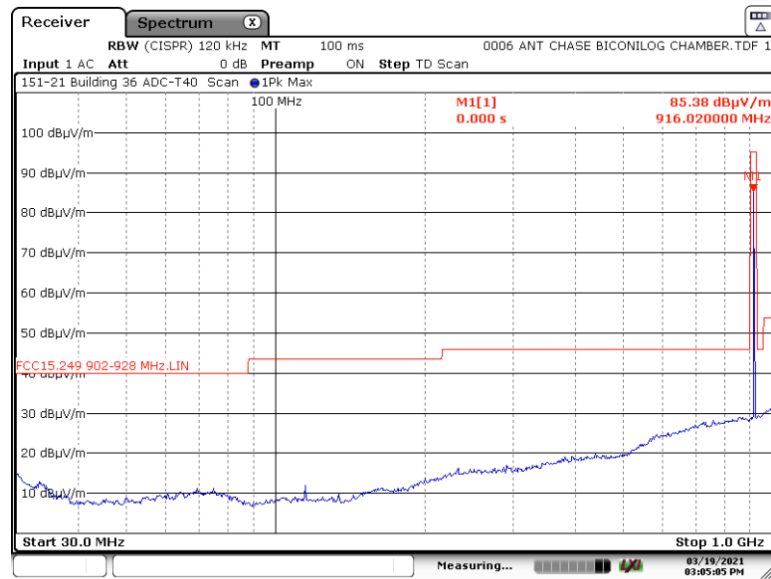

Date: 19 MAR 2021 15:05:05

B.3.2. Measurement Results – Vertical Antenna

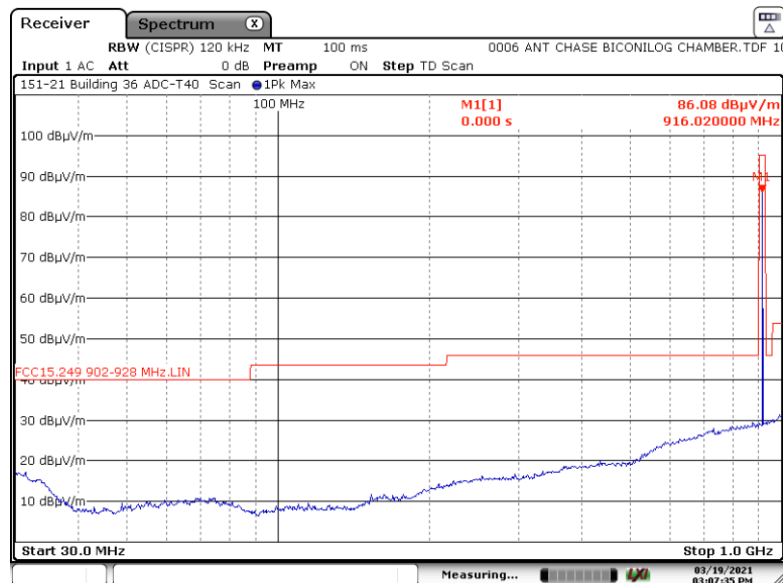

Date: 19 MAR 2021 15:07:35

Appendix B (continued)

**Spurious Radiated Emissions, 30 kHz to EUT 10th Harmonic (15.249, Section (d)),
ISED RSS-GEN, Issue 5 (continued)**

B.4. Spurious Radiated Emissions (1 GHz to 9.4 GHz), Fundamental = 916.0 MHz

B.4.1. Measurement Results – Horizontal Antenna

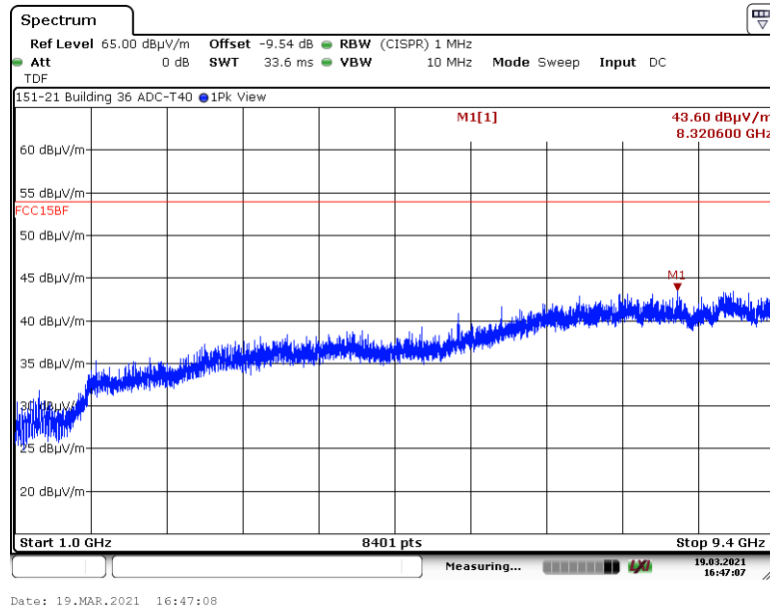

B.4.2. Measurement Results – Vertical Antenna

