

**COMPLIANCE WORLDWIDE INC.
TEST REPORT 155-21**

In Accordance with the Requirements of
**FCC PART 15.247, SUBPART C
ISED Canada RSS-247, Issue 2**

Issued to
**Building 36 Technologies
150 A Street – Suite 104
Needham, MA 02494
781-474-0500**

for the
**ADC-T40 Thermostat
Z-Wave LR Radio**

**FCC ID: 2AC3T-B36T40RA
IC: 12323A-B36T40RA**

Report Issued on March 31, 2021

Prepared by

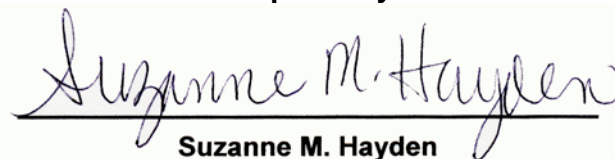

Suzanne M. Hayden

Reviewed By

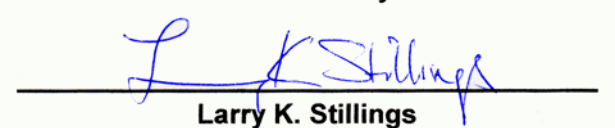

Larry K. Stillings

Table of Contents

1. Scope	3
2 .Product Details	3
2.1 Manufacturer	3
2.2 Model Number	3
2.3 Serial Number	3
2.4 Description	3
2.5 Power Source.....	3
2.6 Hardware Revision	3
2.7 Software Revision	3
2.8 Modulation Type.....	3
2.9 Operating Frequency.....	3
2.10 EMC Modifications	3
3. Product Configuration	3
3.1 Operational Characteristics & Software.....	3
3.2 EUT Hardware.....	3
3.3 EUT Cables/Transducers	3
3.4 Support Equipment.....	4
3.5 Block Diagram	4
4. Measurements Parameters	4
4.1 Measurement Equipment Used to Perform Test	4
4.2 Measurement Software	5
4.3 Measurement & Equipment Setup.....	5
4.4 Measurement Procedures	5
4.5 Measurement Uncertainty	6
5. Choice of Equipment for Test Suits	6
5.1 Choice of Model	6
5.2 Presentation	6
5.3 Choice of Operating Frequencies.....	6
5.4 EUT Positions for Emissions Measurements.....	6
6. Measurement Summary	7
7. Measurement Data	8
7.1 Antenna Requirement	8
7.2 Minimum DTS Bandwidth.....	9
7.3 Maximum Peak Conducted Output Power	11
7.4 Operation with directional antenna gains greater than 6 dBi	13
7.5 Transmitter Spurious Radiated Emissions	14
7.6 Band Edge and Out of Band Measurements.....	16
7.7 Emissions in Non-restricted Frequency Bands.....	19
7.8 Peak Power Spectral Density	20
7.9 Conducted Emissions.....	22
7.10 Duty Cycle	27
7.11 99% (Occupied) Bandwidth	29
7.12 Public Exposure to Radio Frequency Energy Levels.....	31
8. Test Setup Photographs	33
9. Test Site Description.....	41
Appendix A - Transmitter Spurious Radiated Emissions Test Data.....	42
Appendix B - Emissions in Non-restricted Frequency Bands.....	52

1. Scope

This test report certifies that the Building 36 Technologies ADC-T40 Thermostat, Model ADC-T40, as tested, meets the FCC Part 15, Subpart C and ISED Canada RSS-247, Issue 2 requirements. The scope of this test report is limited to the test sample provided by the client, only in as much as that sample represents other production units. If any significant changes are made to the unit, the changes shall be evaluated and a retest may be required.

2. Product Details

- 2.1. **Manufacturer:** Building 36 Technologies
- 2.2. **Model Number:** ADC-T40
- 2.3 **Serial Number:** SA0010210A01000005
- 2.4 **Description of EUT:** Wireless Thermostat
- 2.5 **Power Source:** 24 VAC, from HVAC Equipment
For test purposes, a 24 VAC wall power supply was substituted.
- 2.6 **Hardware Revision:** Rev 3
- 2.7 **Software Revision:** N/A
- 2.8. **Modulation Type:** Gaussian frequency shift keying
- 2.9. **Operating Frequencies:** 912 & 920 MHz
- 2.10. **EMC Modifications:** None

3. Product Configuration

3.1. EUT Hardware

Manufacturer	Model	Serial Number	Input Volts	Freq (Hz) Or DC	Description/Function
Building 36 Technologies	ADC-T40	SA0010210A01000005	24	60	Wireless Thermostat

3.2. Support Equipment

Device	Manufacturer	Model	Serial No.	Comment
24 VAC Transformer	MG Electronics	MGT2420	1805C	AC Power for EUT
Laptop	Lenovo	P50	PC0MHJ8Y	For setting up EUT

3.3. Cables

Cable Type	Length	Shield	From	To
Power Cable	3M	No	EUT	120 VAC / 24 VAC Transformer

3. Product Configuration (continued)

3.4. Operational Characteristics & Software

Apply 24 VAC to the device under test.

A proprietary software, provided by Silicon Labs for EMC testing, called MicroRFLink is used to configure the frequency, modulation type and bandwidth of the DUT. The device will be configured using this software to modulate test frequencies at 912 MHz and 920 MHz

3.5. Block Diagram

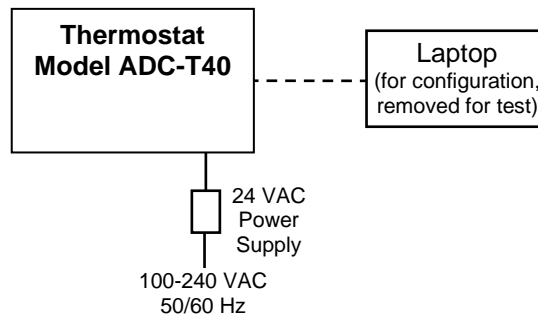

4. Measurements Parameters

4.1. Measurement Equipment Used to Perform Test

Device	Manufacturer	Model No.	Serial No.	Cal Due	Interval
EMI Test Receiver, 9kHz - 7GHz ¹	Rohde & Schwarz	ESR7	101156	10/16/2022	2 Years
EMI Test Receiver, 10 Hz - 7GHz ¹	Rohde & Schwarz	ESR7	101770	7/17/2022	2 Years
Spectrum Analyzer, 2 Hz to 26.5 GHz ²	Rohde & Schwarz	FSW26	102057	9/13/2021	3 Years
Spectrum Analyzer, 9 kHz to 40 GHz ³	Rohde & Schwarz	FSV40	100899	8/12/2022	2 Years
Spectrum Analyzer 10 Hz – 40 GHz ¹	Rohde & Schwarz	FSVR40	100909	9/18/2022	2 Years
Loop Antenna 9 kHz - 30 MHz	EMCO	6512	9309-1139	1/28/2022	3 Years
Biconilog Antenna, 30 MHz - 2 GHz	Sunol Sciences	JB1	A050913	6/5/2021	2 Years
Dbl Ridged Guide Antenna 1- 18 GHz	ETS-Lindgren	3117	00143292	3/21/2022	2 Years
Horn Antenna, 18 GHz to 40 GHz	Com-Power	AH-840	101032	9/8/2021	3 Years
Preamplifier, 1 GHz to 26.5 GHz	Hewlett Packard	8449B	3008A01323	9/11/2021	3 Years
1.8 GHz - 9.3 GHz Passband Filter	Mini-Circuits	VHP-16	0341	3/23/2022	2 Years
Band Reject Filter (Notch), 2.4 GHz	Micro-Tronics	BRM50702	150	3/23/2022	2 Years
Digital Barometer	Control Company	4195	ID236	4/3/2021	3 Years
Temperature Chamber	Associated Environmental	SD-308	10782	CNR	

¹ ESR7 Firmware revision: V3.48 SP3, Date installed: 09/30/2020 Previous V3.48 SP2, installed 07/23/2020.

² FSW26 Firmware revision: V4.71 SP1, Date installed: 11/16/2020 Previous V4.61, installed 08/11/2020.

³ FSV40 Firmware revision: V2.30 SP4, Date installed: 05/04/2016 Previous V2.30 SP1, installed 10/22/2014.

⁴ FSVR40 Firmware revision: V2.23 SP1, Date installed: 08/19/2016 Previous V2.23, installed 10/22/2014.

4. Measurements Parameters

4.2. Measurement Software

Manufacturer	Software Description	Title or Model #	Rev.	Report Sections
Compliance Worldwide	Test Report Generation Software	Test Report Generator	1.0	7.10. Conducted Emissions

4.3. Measurement & Equipment Setup

Test Dates:	3/19/2021 – 4/1/2021
Test Engineers:	Sean Defelice
Normal Site Temperature (15 - 35°C):	21.2
Relative Humidity (20 -75%RH):	35
Frequency Range:	30 kHz to 9.4 GHz
Measurement Distance:	3 Meters
	200 Hz – 9 to 150 kHz
EMI Receiver IF Bandwidth:	9 kHz – 150 kHz to 30 MHz
	120 kHz - 30 MHz to 1 GHz
	1 MHz - Above 1 GHz
EMI Receiver Average Bandwidth:	$\geq 3 * IF (BW) \text{ or } RBW$
Detector Function:	Peak, Quasi-Peak & Average

4.4. Measurement Procedures

Test measurements were made in accordance FCC Part 15.247: Operation within the bands 902 - 928 MHz, 2400 - 2483.5 MHz, 5725 - 5850 MHz, and 24.0 - 24.25 GHz.

The measurement procedures in this report are in accordance with ANSI C63.10-2013: *American National Standard of Procedures for Compliance Testing of Unlicensed Wireless Devices*. FCC OET Publication Number KDB 558074 D01 v05r02, *Guidance for Performing Compliance Measurements on Digital Transmission Systems (DTS), Frequency Hopping Spread Spectrum Systems, and Hybrid System Devices Operating Under §15.247*, dated April 2, 2019, was also referenced for the test procedures used to generate the data in this report. All references to these publications refer to this versions and dates detailed in this paragraph.

4. Measurements Parameters

4.5. Measurement Uncertainty

The following uncertainties are expressed for an expansion/coverage factor of K=2.

RF Frequency	$\pm 1 \times 10^{-8}$
Radiated Emission of Transmitter	± 4.55 dB
Radiated Emission of Receiver	± 4.55 dB
Temperature	$\pm 0.91^{\circ}$ C
Humidity	$\pm 5\%$

5. Choice of Equipment for Test Suits

5.1 Choice of Model

This test report is based on the test samples supplied by the manufacturer and are reported by the manufacturer to be equivalent to the production units.

5.2 Presentation

This test sample was tested complete with all required ancillary equipment. Refer to Section 3 of this report for product equipment configuration.

5.3 Choice of Operating Frequencies

The device under test utilizes two operating frequencies: 912 MHz and 920 MHz. Both frequencies were tested.

5.4 EUT Positions for Emissions Measurements

The device under test is designed to be mounted in a single orientation on a wall. Therefore, testing in three orthogonal positions in accordance with ANSI C63.10-2013, Section 5.10.1 was not required.

6. Measurement Summary

Test Requirement	FCC Rule Requirement	ISED Rule Requirement	Test Report Section	Result
Antenna Requirement	15.203	---	7.1	Compliant
Minimum DTS Bandwidth	15.247 (a) (2)	RSS-247 5.2 a)	7.2	Compliant
Maximum Peak Conducted Output Power	15.247 (b) (1)	RSS-247 5.4 d)	7.3	Compliant
Operation with directional antenna gains greater than 6 dBi	15.247 (b) (4)	---	7.4	Compliant
Spurious Radiated Emissions	15.247 (d)	RSS-GEN 6.13	7.5	Compliant
Spurious Radiated Emissions (> GHz) - Harmonic Measurements	15.247 (d)	RSS-GEN 6.13		Compliant
Band Edge and Out of Band Measurements	15.247 (d)	RSS-GEN 6.13	7.6	Compliant
Emissions in Non-restricted Frequency Bands	15.247(e)	RSS-GEN 6.13	7.7	Compliant
Peak Power Spectral Density	15.247(e)	RSS-247 5.2 b)	7.8	Compliant
AC Power Line Conducted Emissions	15.207	RSS-GEN 7.2	7.9	
Duty Cycle	15.247	N/A	7.10	Compliant
99% (Occupied) Bandwidth	---	RSS-GEN 6.7	7.11	Compliant
Public Exposure to Radio Frequency Energy Levels	1.1307 (b) (1)	RSS-GEN, Issue 5, Section 3.4, RSS 102	7.12	Compliant

7. Measurement Data

7.1. Antenna Requirement (15.203)

Requirement: An intentional radiator shall be designed to ensure that no antenna other than that furnished by the responsible party shall be used with the device. The use of a permanently attached antenna or of an antenna that uses a unique coupling to the intentional radiator shall be considered sufficient to comply with the provisions of this Section.

Results: The EUT utilizes an etch antenna that is not user replaceable.

7. Measurement Data

7.2. Minimum DTS Bandwidth (15.247 (a) (2), ISED_RSS-247 5.2 a))

Requirement: (15.247 (a) (2))

Systems using digital modulation techniques may operate in the 902 - 928 MHz, 2400 - 2483.5 MHz, and 5725 - 5850 MHz bands. The minimum 6 dB bandwidth shall be at least 500 kHz.

Procedure: This test was performed in accordance with the procedure detailed in FCC OET publication number 558074, Section 8.1 Option 1, DTS (6 dB) Channel Bandwidth.

Results: The device under test meets the minimum 500 kHz DTS (6 dB) bandwidth requirement.

Channel	Frequency (MHz)	-6 dB Bandwidth (kHz)	Minimum -6 dB Bandwidth (kHz)	Result
Low	912	641.40	>500	Compliant
High	920	641.40	>500	Compliant

7.2.1. Low Channel – 912 MHz

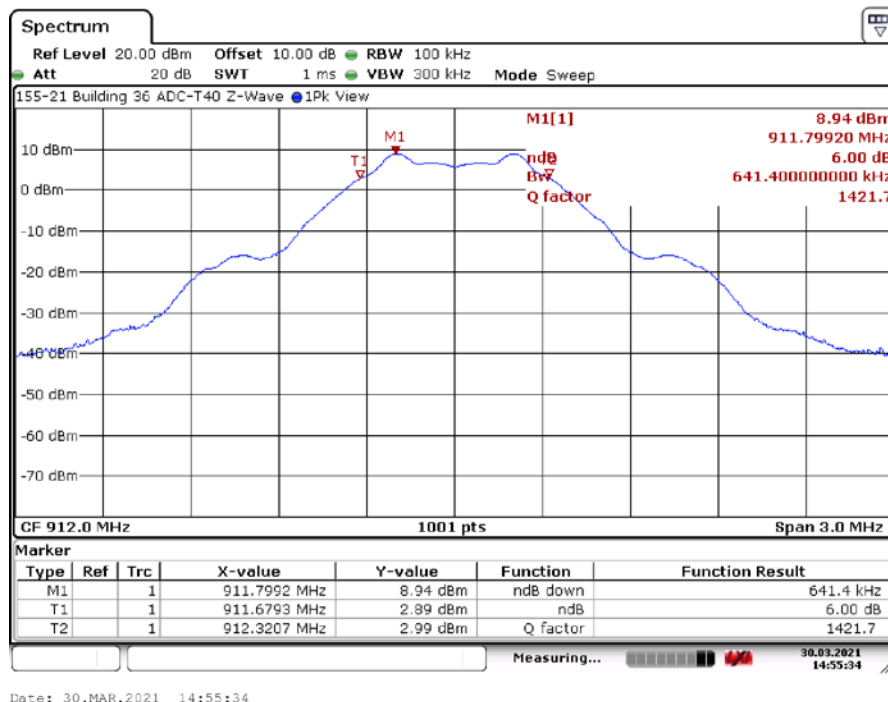

Date: 30.MAR.2021 14:55:34

7. Measurement Data

7.2. Minimum DTS Bandwidth (15.247 (a) (2)) (continued)

7.2.2. High Channel – 920 MHz

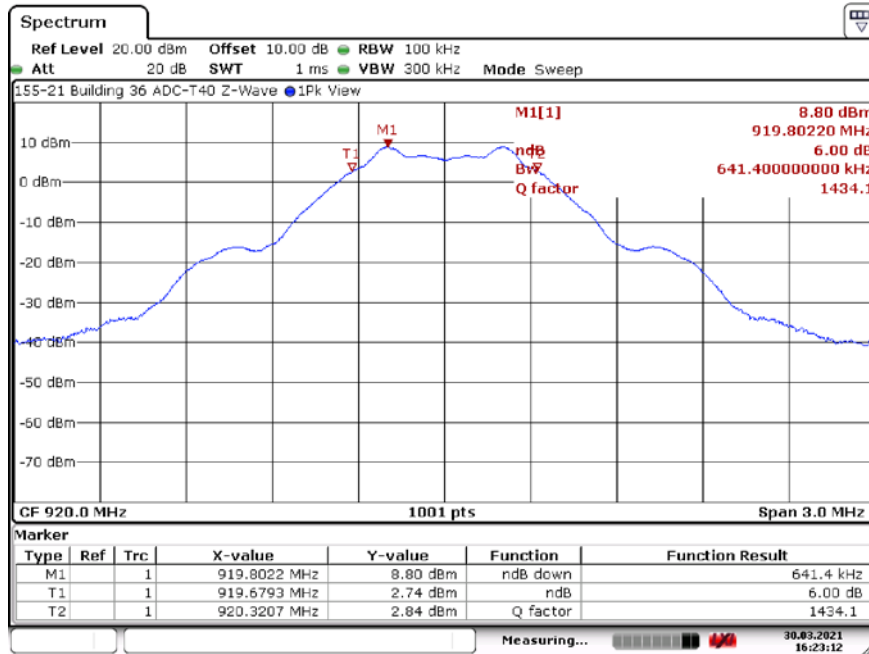

Date: 30.MAR.2021 16:23:12

7. Measurement Data (continued)

7.3. Maximum Peak Conducted Output Power (FCC 15.247 (b)(3), ISED RSS-247 5.4 d)

Requirement: (15.247 (b) (3))

The maximum peak conducted output power of the intentional radiator shall not exceed the following: For systems using digital modulation in the 902–928 MHz, 2400–2483.5 MHz, and 5725–5850 MHz bands: 1 Watt (+30 dBm).

Procedure: This test was performed in accordance with the procedure detailed in FCC OET publication number KDB 558074, Section 9.1.1.

Test Note: A spectrum analyzer resolution bandwidth of 1 MHz and a video bandwidth of 3 MHz were used to meet the requirements of FCC OET publication number 558074, Section 9.1.1 and the measured product DTS bandwidth.

Results: The device under test meets the required maximum peak conducted output power level of 1 Watt (30 dBm).

Channel	Frequency	Maximum Peak Conducted Output Power	Peak Limit	Margin	Result
	(MHz)	(dBm)	(dBm)	(dB)	
Low	912	9.31	30	-20.69	Compliant
High	920	9.13	30	-20.87	Compliant

7.3.1. Low Channel – 912 MHz

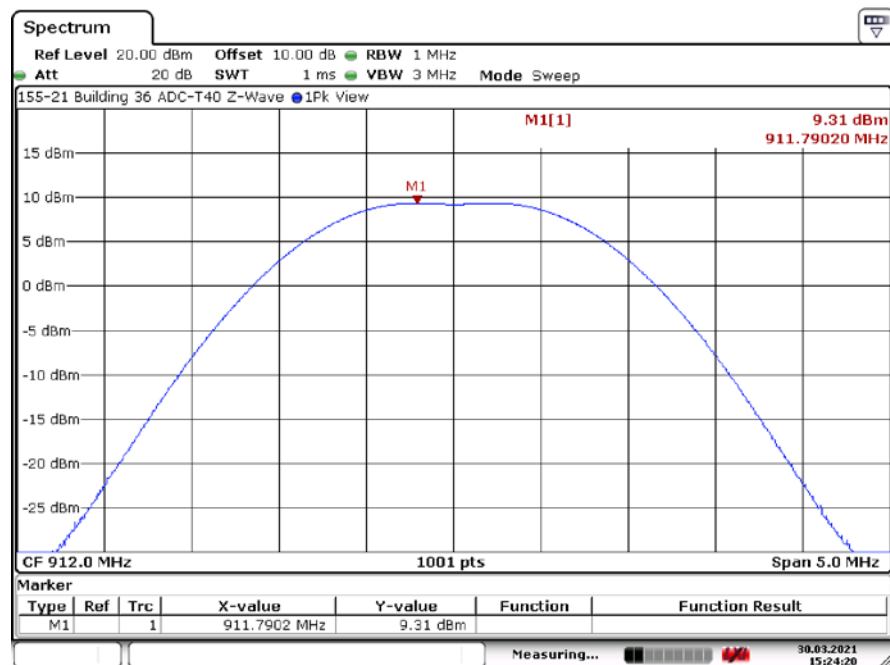

Date: 30.MAR.2021 15:24:21

7. Measurement Data

7.3. Maximum Peak Conducted Output Power (continued)

7.3.2. High Channel – 920 MHz

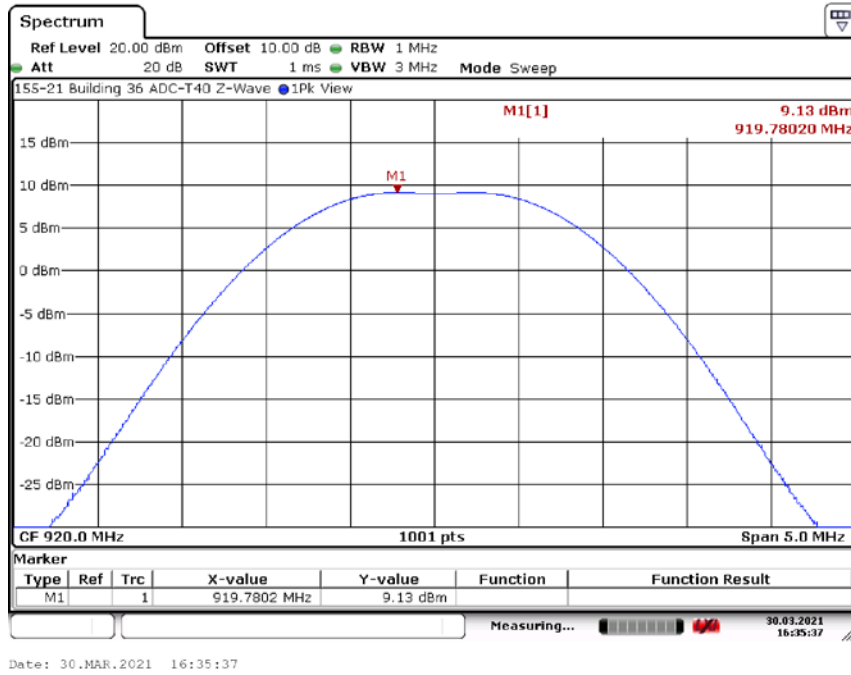

7. Measurement Data

7.4. Operation with directional antenna gains greater than 6 dBi (15.247 (b)(4))

Requirement: If transmitting antennas of directional gain greater than 6 dBi are used, the conducted output power from the intentional radiator shall be reduced below the stated values in paragraphs (b)(1), (b)(2), and (b)(3) of FCC Part 15.247, as appropriate, by the amount in dB that the directional gain of the antenna exceeds 6 dBi.

Systems operating in the 2400 – 2483.5 MHz band that are used exclusively for fixed, point-to-point operations may employ transmitting antennas with directional gain greater than 6 dBi provided the maximum peak output power of the intentional radiator is reduced by 1 dB for every 3 dB that the directional gain of the antenna exceeds 6 dBi.

Systems operating in the 5725 – 5850 MHz band that are used exclusively for fixed, point-to-point operations may employ transmitting antennas with directional gain greater than 6 dBi without any corresponding reduction in transmitter peak output power.

Procedure: Not applicable for the device under test.

DUT Status: The DUT utilizes an antenna with an approximate peak gain of 8.0 dBi, however its maximum conducted output power is 9.31 dBm and therefore is exempt from this requirement.

7. Measurement Data (continued)

7.5. Transmitter Spurious Radiated Emissions (30 kHz to 9.4 GHz) (FCC 15.209, ISED RSS-GEN 6.13)

7.5.1 Transmitter Spurious Radiated Emissions

Requirement: (15.209) The Emissions from an intentional radiator shall not exceed the field strength levels specified in the following table:

Frequency Range (MHz)	Distance (Meters)	Limit (dB μ V/m) ¹
0.009 to 0.490	3	128.5 to 93.8
0.490 to 1.705	3	73.8 to 63.0
1.705 to 30	3	69.5
30 to 88	3	40.0
88 to 216	3	43.5
216 to 960	3	46.0
>960	3	54.0

¹Measurements in the 9 to 90 kHz, 110 to 490 kHz and above 1000 MHz ranges employ an average detector. Otherwise a quasi-peak detector is used.

Procedure: This test was performed in accordance with the procedure detailed in FCC OET publication number 558074, Section 12.0: Emissions in restricted frequency bands and FCC 47CFR Part 15.209: Radiated Emission Limits; General Requirements.

The test methods used to generate the data in this test report is in accordance with ANSI C63.10:2013, American National Standard for Testing Unlicensed Wireless Devices.

Test Notes: Measurements were made from the lowest oscillator frequency as stated by the manufacturer (32.768 kHz) to the 10th harmonic of the highest transmitter frequency or 40 GHz, whichever is lower.

Reference FCC Part 15.33(a) and FCC Part 15.33(a)(1).

Each of the test modes documented within the test report were evaluated and the worst case of each of the test modes is detailed in this section. A full set of measurement scans are presented in Appendix A of this test report.

Results: The Emissions from the DUT did not exceed the field strength levels specified in the above table.

Sample Calculation: Final Result (dB μ V/m) = Measurement Value (dB μ V) + Antenna Factor (dB/m) + Cable Loss (dB) – Pre-amplifier Gain (dB) Internal or External.

Note: All correction factors are loaded into the measurement instrument prior to testing to determine the final result.

7. Measurement Data (continued)

7.5. Transmitter Spurious Radiated Emissions (30 kHz to 9.4 GHz) (FCC 15.209, ISED RSS-GEN 6.13)

7.5.2. Transmitter Spurious Radiated Emissions (Harmonic Meas.) Test Results

Worst case measurements of Harmonics that fall into the restricted bands.

7.5.2.1. Fundamental Frequency = 912 MHz

Freq. (MHz)	Field Strength (dB μ V/m)		Limit (dB μ V/m)		Margin (dB μ V/m)		Antenna Polarity (H/V)	Result
	Peak	Average	Peak	Average	Peak	Average		
2736.00	48.15	35.19	74.00	54.00	-25.85	-18.81	V	Compliant
3648.00	51.57	39.44	74.00	54.00	-22.43	-14.56	V	Compliant
4560.00	52.88	40.86	74.00	54.00	-21.12	-13.14	H	Compliant
7296.00	52.67	41.04	74.00	54.00	-21.33	-12.96	H	Compliant
8208.00	54.09	42.99	74.00	54.00	-19.91	-11.01	H	Compliant
9120.00	51.99	40.68	74.00	54.00	-22.01	-13.32	H	Compliant

¹ All correction factors are stored in the spectrum analyzer and applied to these column entries.

7.5.2.2. Fundamental Frequency = 920 MHz

Freq. (MHz)	Field Strength (dB μ V/m)		Limit (dB μ V/m)		Margin (dB μ V/m)		Antenna Polarity (H/V)	Result
	Peak	Average	Peak	Average	Peak	Average		
2760.00	47.92	34.99	74.00	54.00	-26.08	-19.01	H	Compliant
3680.00	51.39	39.16	74.00	54.00	-22.61	-14.84	V	Compliant
4600.00	52.86	40.51	74.00	54.00	-21.14	-13.49	H	Compliant
7360.00	52.72	40.78	74.00	54.00	-21.28	-13.22	V	Compliant
8280.00	54.51	42.81	74.00	54.00	-19.49	-11.19	V	Compliant
9200.00	52.45	40.38	74.00	54.00	-21.55	-13.62	H	Compliant

¹ All correction factors are stored in the spectrum analyzer and applied to these column entries.

7. Measurement Data (continued)

7.6. Band Edge and Out of Band Measurements (FCC 15.209, ISSED RSS-GEN 6.13)

Requirement: 15.247(d) In any 100 kHz bandwidth outside the frequency band in which the spread spectrum or digitally modulated intentional radiator is operating, the radio frequency power that is produced by the intentional radiator shall be at least 20 dB below that in the 100 kHz bandwidth within the band that contains the highest level of the desired power, based on either an RF conducted or a radiated measurement, provided the transmitter demonstrates compliance with the peak conducted power limits. If the transmitter complies with the conducted power limits based on the use of RMS averaging over a time interval, as permitted under paragraph (b)(3) of this section, the attenuation required under this paragraph shall be 30 dB instead of 20 dB. Attenuation below the general limits specified in Section 15.209(a) is not required. In addition, radiated emissions which fall in the restricted bands, as defined in Section 15.205(a), must also comply with the radiated emission limits specified in Section 15.209(a) (see Section 15.205(c)).

Procedure: For the band edges, this measurement was performed in accordance with the procedure detailed in FCC OET publication number 558074, Section 11: Emissions in non-restricted frequency bands.

Results: The DUT met the 20 dB requirement at the band edges.

7.6.1. Lower Band Edge

Band Edge Frequency	Lowest Transmitter Frequency	Maximum PSD (100 kHz)	Band Edge Delta to Max PSD (100 kHz)	Minimum Required Delta	Result
(MHz)	(MHz)	(dBm)	(dB)	(dB)	
902	912	8.98	-58.96	-20	Compliant

Note: Reference the plot on the following page.

7. Measurement Data (continued)

7.6. Band Edge and Out of Band Measurements (continued)

Lower Band Edge

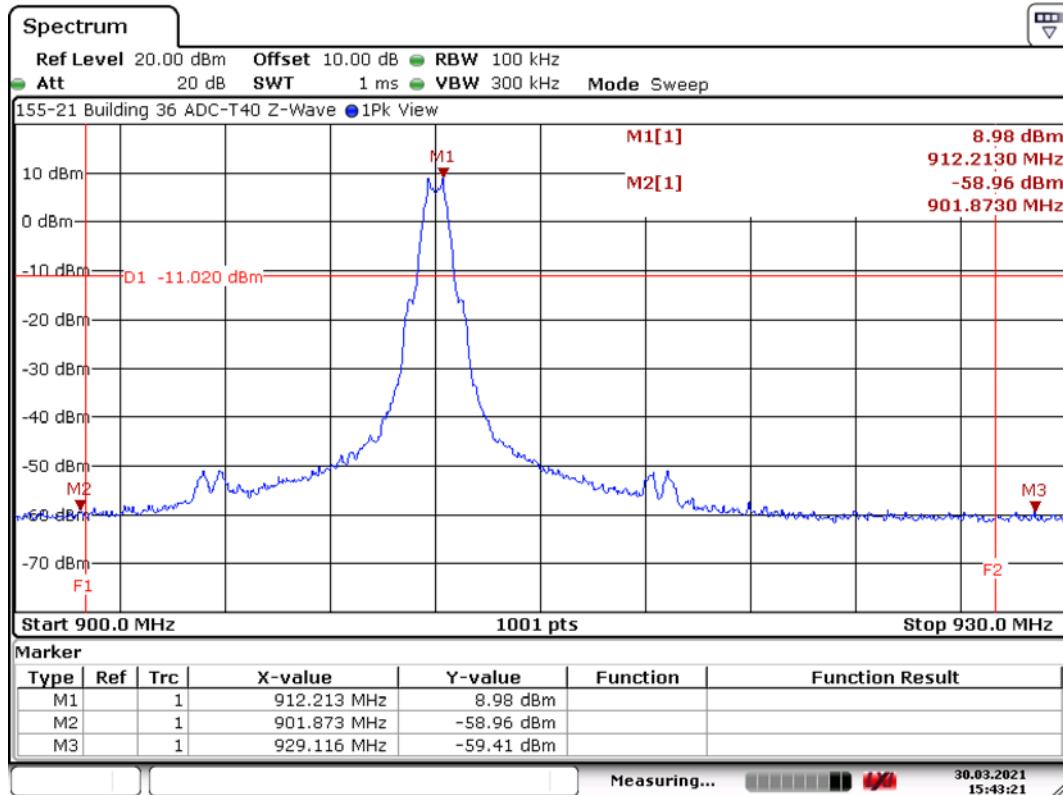

Date: 30.MAR.2021 15:43:22

7.6.2. Upper Band Edge

Band Edge Frequency	Lowest Transmitter Frequency	Maximum PSD (100 kHz)	Band Edge Delta to Max PSD (100 kHz)	Minimum Required Delta	Result
(MHz)	(MHz)	(dBm)	(dB)	(dB)	
928	920	8.80	-59.99	-20	Compliant

Note: Reference the plot on the following page.

7. Measurement Data (continued)

7.6. Band Edge and Out of Band Measurements (continued)

Upper Band Edge

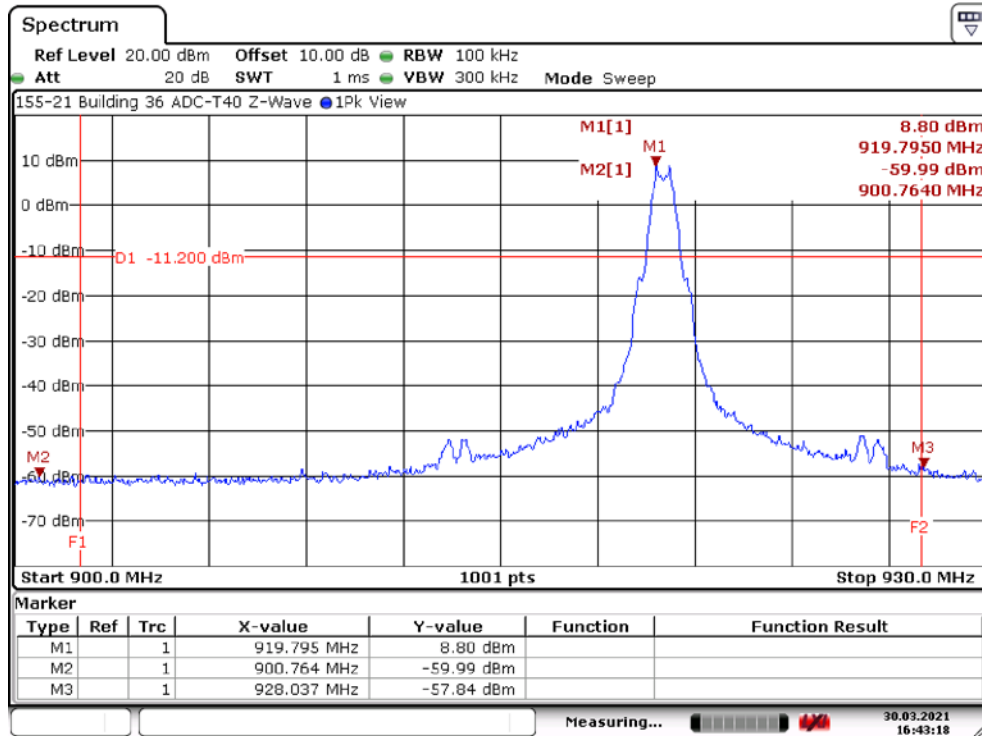

Date: 30.MAR.2021 16:43:17

7. Measurement Data (continued)

7.7. Emissions in Non-restricted Frequency Bands

Requirement: 15.247(d) In any 100 kHz bandwidth outside the frequency band in which the spread spectrum or digitally modulated intentional radiator is operating, the radio frequency power that is produced by the intentional radiator shall be at least 20 dB below that in the 100 kHz bandwidth within the band that contains the highest level of the desired power, based on either an RF conducted or a radiated measurement, provided the transmitter demonstrates compliance with the peak conducted power limits.

Test Notes: Peak in-band measurements were taken at the time the DTS (-6 dB) bandwidth measurements were made. These values were used as the reference levels for the following measurements. Refer to section 7.2 of this report for these values.

Reference Appendix B for the measurement data used for this test section.

Results: The DUT met the 20 dB requirement emission level delta requirement in the non restricted frequency bands.

Emissions in Non-restricted Frequency Bands

Maximum PSD (100 kHz) In-Band ¹ (dBm)	Worst Case Out-of-Band Frequency (MHz)	Maximum PSD (100 kHz) Out-of-Band (dBm)	Delta to Maximum PSD (dB)	Minimum Required Delta (dB)	Result
8.98	1824	-35.64	-44.62	-11.02	Compliant

¹Taken from Section 7.2 - DTS Bandwidth

7. Measurement Data (continued)

7.8. Peak Power Spectral Density (FCC 15.247(e), ISED RSS-247, 5.2 b))

Requirement: For digitally modulated systems, the power spectral density conducted from the intentional radiator to the antenna shall not be greater than 8 dBm in any 3 kHz band during any time interval of continuous transmission. This power spectral density shall be determined in accordance with the provisions of paragraph (b) of FCC Part 15.247. The same method of determining the conducted output power shall be used to determine the power spectral density.

Procedure: FCC OET publication number 558074, Section 10.2: Method PKPSD (peak PSD). FCC OET 662911 was referenced to determine the procedure for measuring in-band power spectral density of transmitters with multiple outputs in the same band.

Results: The DUT met the required power spectral density limit at the tested frequencies.

Measurement Results in 902-928 MHz Band

Channel	Frequency	Maximum PSD Frequency	Maximum Power Spectral Density	Limit	Margin	Result
	(MHz)	(MHz)	(dBm)	(dBm)	(dB)	
Low	912	912.199	-2.75	8	-10.75	Compliant
High	920	920.199	-2.93	8	-10.93	Compliant

7. Measurement Data (continued)

7.8. Peak Power Spectral Density (15.247(e)), ISED RSS-247, 5.2 b)) (continued)

7.8.1. Low Channel – 912 MHz

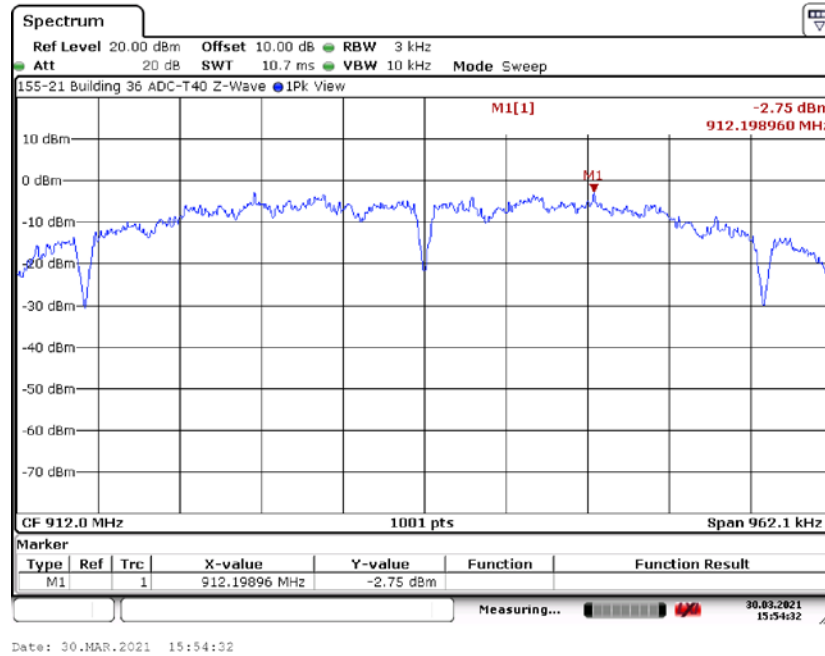

7.8.2. High Channel – 920 MHz

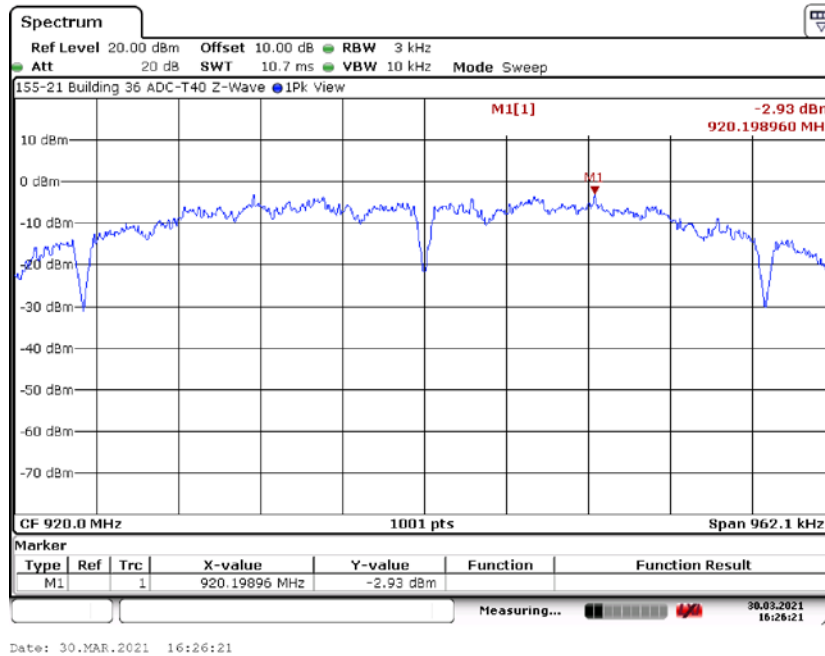

7. Measurement Data (continued)

7.9. Conducted Emissions

Requirement: 15.207 With certain exceptions, an intentional radiator that is designed to be connected to the public utility (AC) power line, the radio frequency voltage that is conducted back onto the AC power line on any frequency or frequencies, within the band 150 kHz to 30 MHz, shall not exceed the limits in the following table, as measured using a 50 μ H/50 ohms line impedance stabilization network (LISN).

Frequency Range (MHz)	Limits (dB μ V)	
	Quasi-Peak	Average
0.15 to 0.50	66 to 56*	56 to 46*
0.50 to 5.0	56	46
5.0 to 30.0	60	50

* Decreases with the logarithm of the frequency.

Procedure: This test was performed in accordance with the procedure detailed in ANSI C63.10-2013, Section 6.2: Standard test method for ac power-line conducted emissions from unlicensed wireless devices.

Test Notes: The device was tested using the support equipment laptop.

Results: The device under test meets the FCC Part 15.207 test requirements.

Measurement & Equipment Setup

Test Date: 4/1/2021
 Test Engineer: Sean Defelice
 Site Temperature ($^{\circ}$ C): 22.5
 Relative Humidity (%RH): 43
 Frequency Range: 0.15 MHz to 30 MHz
 EMI Receiver IF Bandwidth: 9 kHz
 EMI Receiver Avg Bandwidth: $\geq 3 * \text{IF BW (RBW)}$
 Detector Functions: Peak, Quasi-Peak & Average

Sample Calculation: Final Result (dB μ V) = Measurement Value (dB μ V) + LISN Insertion Loss (dB) + Cable Loss (dB).

Note: All correction factors are loaded into the measurement instrument prior to testing to determine the final result.

7. Conducted Emissions Test Results

7.9. Conducted Emissions (FCC Part 15.207)

7.9.1. 120 Volts, 60 Hz Phase

Test No.: 159-21, 120 Volts, 60 Hz Phase

FCC, Class B

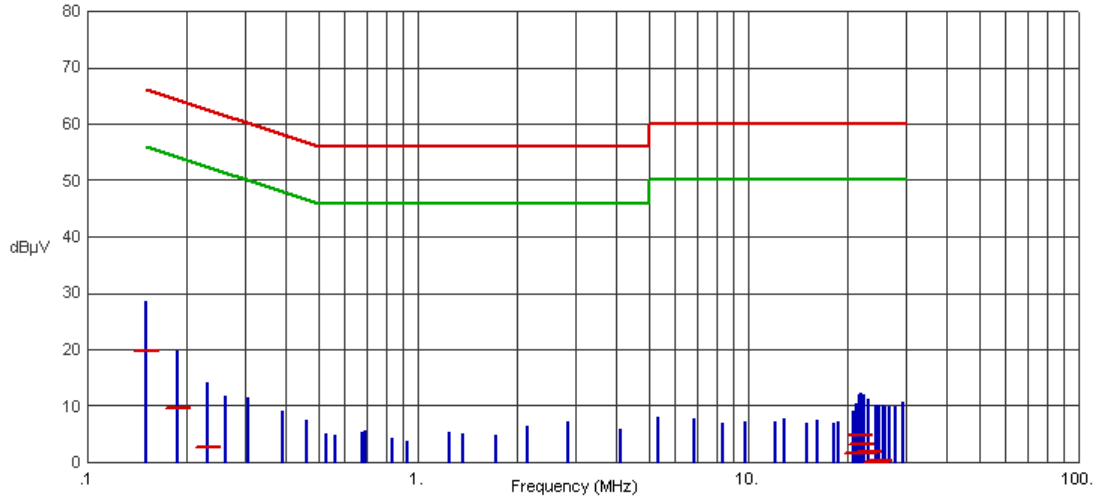

Frequency (MHz)	Pk Amp (dBμV)	QP Amp (dBμV)	QP Limit (dBμV)	QP Margin (dB)	Avg Amp (dBμV)	Avg Limit (dBμV)	Avg Margin (dB)	Comments
.1500	28.56	19.84	66.00	-46.16	-3.23	56.00	-59.23	
.1883	19.68	9.61	64.11	-54.50	-7.86	54.11	-61.97	
.2310	14.09	2.69	62.41	-59.72	-9.45	52.41	-61.86	
.2625	11.85	-1.07	61.35	-62.42	-10.20	51.35	-61.55	
.3075	11.35	-3.40	60.04	-63.44	-10.89	50.04	-60.93	
.3908	9.07	-4.59	58.05	-62.64	-11.37	48.05	-59.42	
.4628	7.54	-5.99	56.64	-62.63	-11.87	46.64	-58.51	
.5303	5.09	-6.54	56.00	-62.54	-12.02	46.00	-58.02	
.5618	4.77	-6.52	56.00	-62.52	-12.13	46.00	-58.13	
.6765	5.20	-6.68	56.00	-62.68	-12.14	46.00	-58.14	
.6968	5.50	-6.57	56.00	-62.57	-12.22	46.00	-58.22	
.8408	4.36	-6.60	56.00	-62.60	-12.01	46.00	-58.01	
.9263	3.69	-6.58	56.00	-62.58	-12.10	46.00	-58.10	
1.2480	5.28	-6.57	56.00	-62.57	-12.03	46.00	-58.03	
1.3628	5.00	-6.39	56.00	-62.39	-11.91	46.00	-57.91	
1.7250	4.87	-5.57	56.00	-61.57	-10.84	46.00	-56.84	
2.1458	6.50	-6.29	56.00	-62.29	-11.58	46.00	-57.58	
2.8365	7.20	-3.44	56.00	-59.44	-8.85	46.00	-54.85	
4.0920	5.95	-4.68	56.00	-60.68	-10.19	46.00	-56.19	
5.3475	7.94	-4.15	60.00	-64.15	-9.63	50.00	-59.63	
6.8685	7.70	-3.80	60.00	-63.80	-9.37	50.00	-59.37	
8.3873	6.95	-3.95	60.00	-63.95	-9.22	50.00	-59.22	
9.7845	7.29	-3.77	60.00	-63.77	-9.19	50.00	-59.19	
12.0593	7.32	-3.61	60.00	-63.61	-8.96	50.00	-58.96	
12.8220	7.75	-3.77	60.00	-63.77	-9.21	50.00	-59.21	
15.0765	6.83	-4.30	60.00	-64.30	-9.55	50.00	-59.55	
16.2285	7.59	-3.60	60.00	-63.60	-9.40	50.00	-59.40	
18.0758	7.00	-4.07	60.00	-64.07	-9.71	50.00	-59.71	
18.7665	7.26	-4.30	60.00	-64.30	-9.46	50.00	-59.46	
20.8208	9.07	-3.05	60.00	-63.05	-8.34	50.00	-58.34	
21.1740	10.35	1.52	60.00	-58.48	-3.68	50.00	-53.68	
21.6645	11.97	4.79	60.00	-55.21	-.09	50.00	-50.09	

7. Conducted Emissions Test Results

7.9. Conducted Emissions (FCC Part 15.207 continued)

7.9.1. 120 Volts, 60 Hz Phase (continued)

Frequency (MHz)	Pk Amp (dB μ V)	QP Amp (dB μ V)	QP Limit (dB μ V)	QP Margin (dB)	Avg Amp (dB μ V)	Avg Limit (dB μ V)	Avg Margin (dB)	Comments
21.9075	12.32	3.20	60.00	-56.80	-.93	50.00	-50.93	
22.4565	11.91	1.50	60.00	-58.50	-2.85	50.00	-52.85	
23.1293	11.07	1.84	60.00	-58.16	-3.25	50.00	-53.25	
24.3488	10.05	.10	60.00	-59.90	-4.85	50.00	-54.85	
24.9000	10.14	.32	60.00	-59.68	-5.64	50.00	-55.64	
25.5975	10.10	-1.39	60.00	-61.39	-6.68	50.00	-56.68	
25.8608	9.94	-1.86	60.00	-61.86	-7.23	50.00	-57.23	
26.6100	9.97	-.15	60.00	-60.15	-5.54	50.00	-55.54	
28.0140	9.88	-.85	60.00	-60.85	-6.43	50.00	-56.43	
29.4270	10.60	-.47	60.00	-60.47	-5.80	50.00	-55.80	

7. Conducted Emissions Test Results

7.9. Conducted Emissions (FCC Part 15.207 continued)

7.9.2. 120 Volts, 60 Hz Neutral

Test No.: 159-21, 120 Volts, 60 Hz Neutral

FCC, Class B

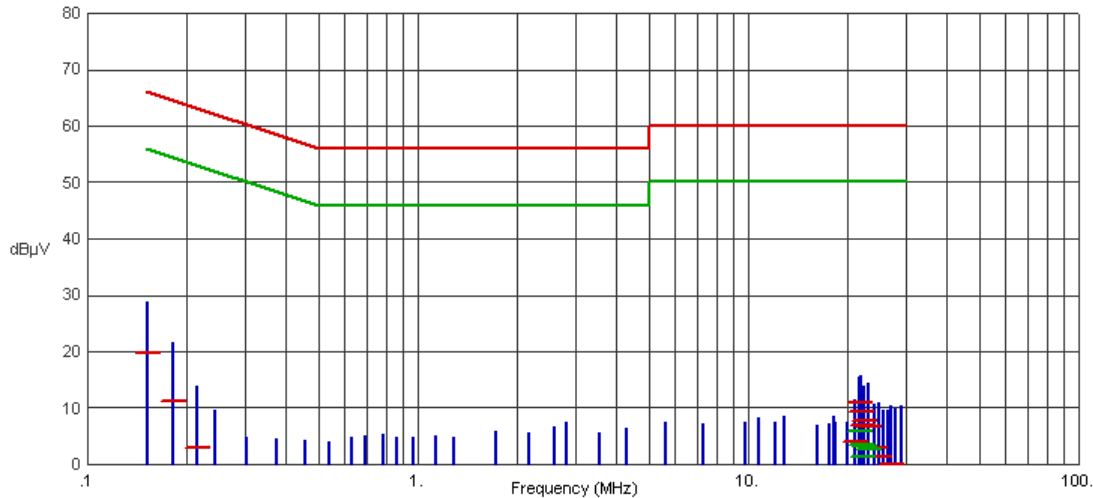

Frequency (MHz)	Pk Amp (dBμV)	QP Amp (dBμV)	QP Limit (dBμV)	QP Margin (dB)	Avg Amp (dBμV)	Avg Limit (dBμV)	Avg Margin (dB)	Comments
.1523	28.79	19.75	65.87	-46.12	-3.40	55.87	-59.27	
.1815	21.63	11.08	64.42	-53.34	-7.49	54.42	-61.91	
.2153	13.99	3.00	63.00	-60.00	-9.17	53.00	-62.17	
.2445	9.70	-2.70	61.94	-64.64	-10.18	51.94	-62.12	
.3030	4.70	-5.38	60.16	-65.54	-11.00	50.16	-61.16	
.3750	4.47	-5.98	58.39	-64.37	-11.42	48.39	-59.81	
.4538	4.15	-6.35	56.81	-63.16	-11.81	46.81	-58.62	
.5393	4.03	-6.68	56.00	-62.68	-11.83	46.00	-57.83	
.6315	4.82	-6.64	56.00	-62.64	-12.03	46.00	-58.03	
.6923	5.10	-6.67	56.00	-62.67	-11.92	46.00	-57.92	
.7868	5.43	-6.46	56.00	-62.46	-11.90	46.00	-57.90	
.8610	4.70	-5.48	56.00	-61.48	-10.70	46.00	-56.70	
.9668	4.85	-6.34	56.00	-62.34	-11.57	46.00	-57.57	
1.1378	5.02	-6.07	56.00	-62.07	-11.63	46.00	-57.63	
1.2885	4.71	-6.12	56.00	-62.12	-11.44	46.00	-57.44	
1.7250	5.94	-4.54	56.00	-60.54	-9.88	46.00	-55.88	
2.1593	5.62	-5.55	56.00	-61.55	-10.94	46.00	-56.94	
2.5868	6.73	-3.03	56.00	-59.03	-8.62	46.00	-54.62	
2.8185	7.36	-2.40	56.00	-58.40	-7.80	46.00	-53.80	
3.5385	5.64	-4.93	56.00	-60.93	-10.42	46.00	-56.42	
4.2990	6.53	-4.69	56.00	-60.69	-9.96	46.00	-55.96	
5.6018	7.54	-2.63	60.00	-62.63	-8.09	50.00	-58.09	
7.3185	7.21	-3.75	60.00	-63.75	-9.02	50.00	-59.02	
9.7418	7.34	-3.64	60.00	-63.64	-8.98	50.00	-58.98	
10.7903	8.36	-2.42	60.00	-62.42	-8.35	50.00	-58.35	
12.0840	7.37	-2.65	60.00	-62.65	-8.27	50.00	-58.27	
12.7995	8.51	-1.06	60.00	-61.06	-6.97	50.00	-56.97	
16.1498	6.96	-3.90	60.00	-63.90	-9.40	50.00	-59.40	
17.6865	7.28	-3.80	60.00	-63.80	-9.34	50.00	-59.34	
18.2400	8.42	-2.76	60.00	-62.76	-8.12	50.00	-58.12	
18.3615	7.39	-3.13	60.00	-63.13	-8.58	50.00	-58.58	

7. Conducted Emissions Test Results

7.9. Conducted Emissions (FCC Part 15.207 continued)

7.9.2. 120 Volts, 60 Hz Neutral (continued)

Frequency (MHz)	Pk Amp (dB μ V)	QP Amp (dB μ V)	QP Limit (dB μ V)	QP Margin (dB)	Avg Amp (dB μ V)	Avg Limit (dB μ V)	Avg Margin (dB)	Comments
20.0490	7.46	-3.00	60.00	-63.00	-8.62	50.00	-58.62	
21.1133	11.38	4.01	60.00	-55.99	-3.05	50.00	-53.05	
21.6645	15.42	10.94	60.00	-49.06	5.96	50.00	-44.04	
21.9075	15.75	9.21	60.00	-50.79	3.57	50.00	-46.43	
22.2135	13.84	7.04	60.00	-52.96	1.42	50.00	-48.58	
22.4565	13.75	7.74	60.00	-52.26	3.07	50.00	-46.93	
23.1293	14.48	6.74	60.00	-53.26	2.57	50.00	-47.43	
24.0450	10.76	3.05	60.00	-56.95	-3.17	50.00	-53.17	
24.9608	10.94	1.46	60.00	-58.54	-3.74	50.00	-53.74	
25.6043	9.56	-1.43	60.00	-61.43	-6.88	50.00	-56.88	
26.5448	9.67	-0.74	60.00	-60.74	-6.46	50.00	-56.46	
27.1568	10.33	.01	60.00	-59.99	-5.86	50.00	-55.86	
27.9960	9.94	-0.78	60.00	-60.78	-6.51	50.00	-56.51	
29.0580	10.51	-0.22	60.00	-60.22	-5.93	50.00	-55.93	

7. Measurement Data (continued)

7.10. Duty Cycle

Requirement: (FCC OET publication number 558074)
Preferably, all measurements of maximum conducted (average) output power will be performed with the EUT transmitting continuously (i.e., with a duty cycle of greater than or equal to 98%).

Procedure: Duty cycle measurements were made according to the procedure detailed ANSI C63.10-2013, Section 11.6(b). Various spans were analyzed to determine if there was any off time. 100 mS span was used.

Results: Duty cycle measurements are listed in the following table.

Channel	Frequency	Time High	Time per Period	Duty Cycle	
	(MHz)	(mS)	(mS)	(Numeric)	(%)
Low	912	1.000	1.000	1.0	100.00
High	920	1.000	1.000	1.0	100.00

7.10.1. Low Channel – 912 MHz

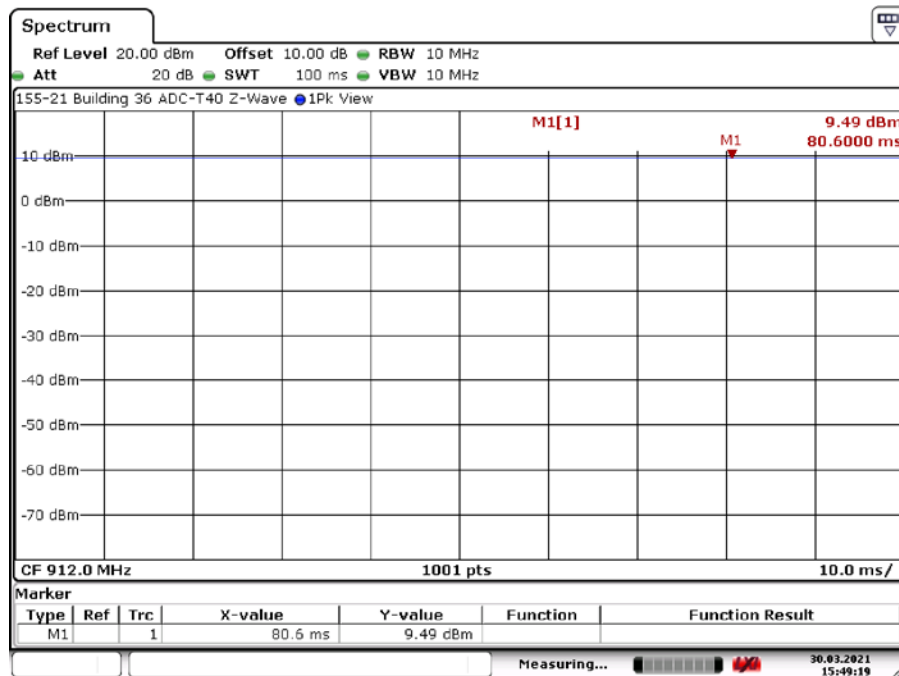

Date: 30.MAR.2021 15:49:20

7. Measurement Data (continued)

7.10. Duty Cycle (continued)

7.10.2. High Channel – 920 MHz

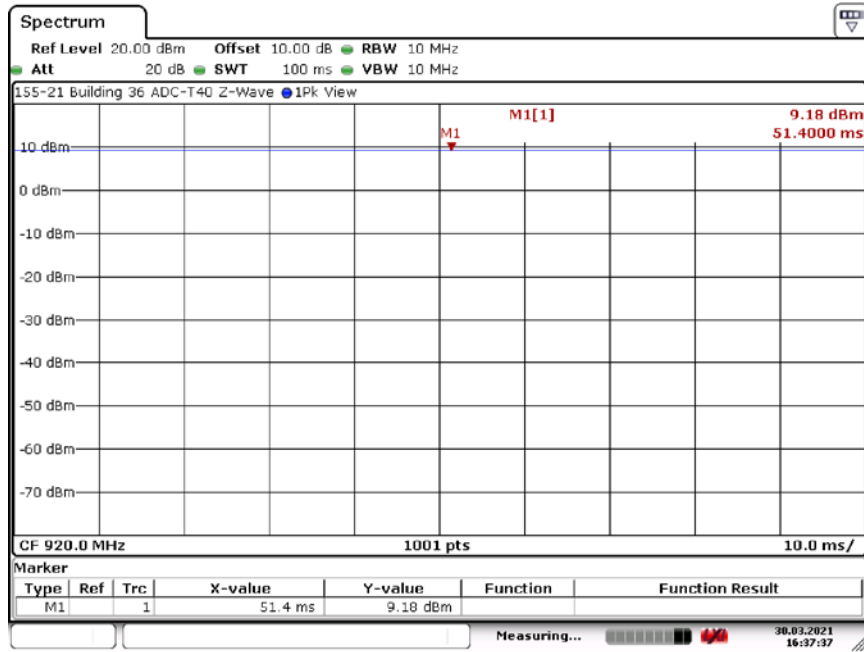

Date: 30.MAR.2021 16:37:37

7. Measurement Data (continued)

7.11. 99% (Occupied) Bandwidth (RSS-GEN 6.7)

Requirement: The occupied bandwidth shall be reported for all equipment in addition to the specified bandwidth required in the applicable RSSs.

The resolution bandwidth (RBW) shall be in the range of 1% to 5% of the actual occupied / x dB bandwidth and the video bandwidth (VBW) shall not be smaller than three times the RBW value.

The sample detector of the spectrum analyzer shall be used to make the measurement.

7.11.1. Measurement Results

Channel	Channel Frequency (MHz)	99% Power Bandwidth (kHz)
Low	912	935.06
High	920	935.06

7.11.1.1. 99% Power Bandwidth – Low Frequency (912 MHz)

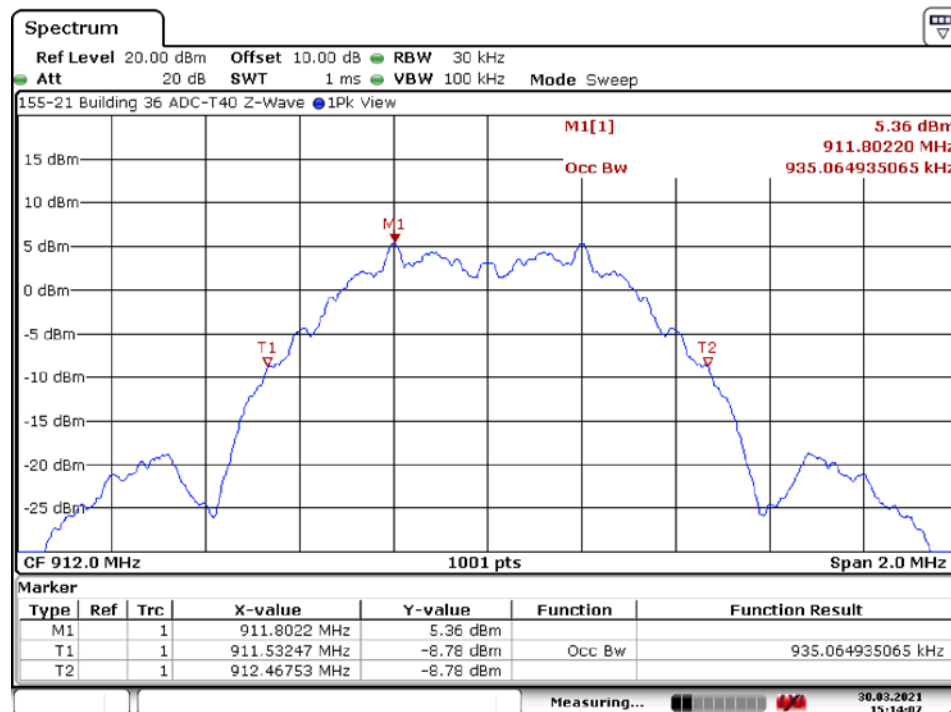

Date: 30.MAR.2021 15:14:08

7. Measurement Data (continued)

7.11. 99% (Occupied) Bandwidth (RSS-GEN 6.7)

7.11.1.4. 99% Power Bandwidth – High Frequency (920 MHz)

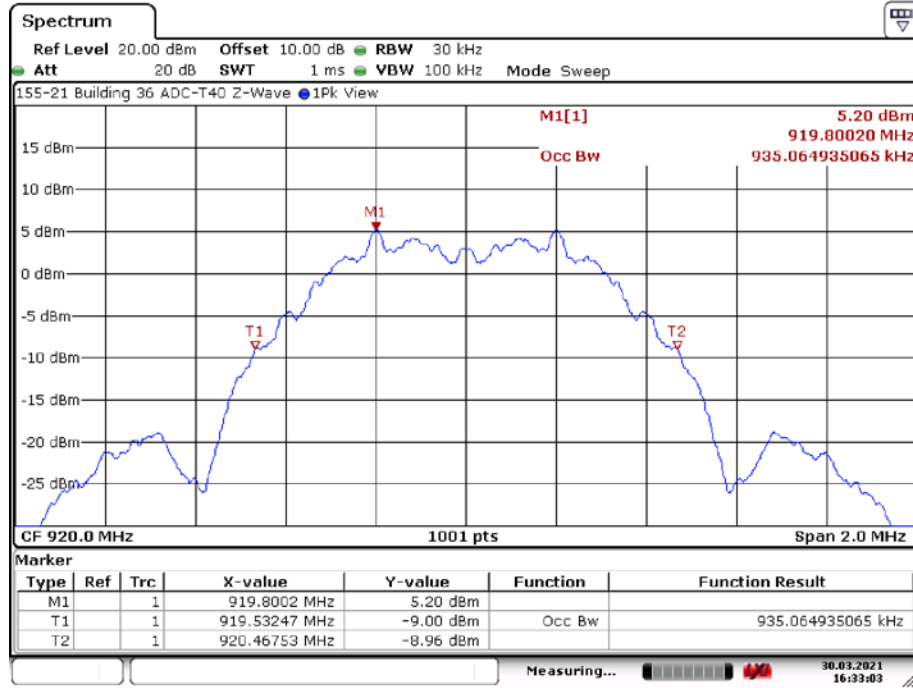

Date: 30.MAR.2021 16:33:03

7. Measurement Data (continued)

7.12. Public Exposure to Radio Frequency Energy Levels ((1.1307 (b)(1)) RSS-GEN, ISSUE 5, RSS-102)

7.12.1. 1.1307 (b) (1) Public Exposure

Requirement: Systems operating under the provisions of this section shall be operated in a manner that ensures that the public is not exposed to radio frequency energy levels in excess of the Commission's guidelines.

Frequency (MHz)	MPE Distance (cm)	DUT Output Power (dBm)	DUT Antenna Gain (dBi)	Power Density		Limit (mW/cm ²)	Result
				(mW/cm ²)	(W/m ²)		
				(4)			
912.0000	20	9.31	8	0.010708537	0.10708537	0.6080000	Compliant
920.0000	20	9.13	8	0.010273777	0.10273777	0.6133333	Compliant

$$PD = \frac{OP + AG}{(4 \times \pi \times d^2)}$$

- PD = Power Density (mW/cm²)
- OP = DUT Output Power (dBm)
- AG = DUT Antenna Gain (dBi)
- d = MPE Distance (cm)

1. Reference CFR 2.1091: For purposes of this section, a mobile device is defined as a transmitting device designed to be used in other than fixed locations and to generally be used in such a way that a separation distance of at least 20 centimeters is normally maintained between the transmitter's radiating structure(s) and the body of the user or nearby persons.
2. Table 6.2 of this test report.
3. Estimated Antenna gain comparing radiated measurements to conducted measurements.
4. Power density is calculated from field strength measurement and antenna gain.
5. Reference CFR 1.1310, Table 1: Limits for Maximum Permissible Exposure (MPE), Section (B): Limits for General Population/Uncontrolled Exposure. Limit = f/1500, where f is in MHz.

Results: Passed - The device under test meets the exclusion requirement detailed for a device with a separation distance of 20 cm.

7. Measurement Data (continued)

7.12. Public Exposure to Radio Frequency Energy Levels ((1.1307 (b)(1)) RSS-GEN, ISSUE 5, RSS-102 continued)

7.12.2. RSS-102 Issue 5 Requirements

Requirement: Requirement: RF exposure evaluation is required if the separation distance between the user and/or bystander and the device's radiating element is greater than 20 cm, except when the device operates as follows:

at or above 300 MHz and below 6 GHz and the source-based, time-averaged maximum e.i.r.p. of the device is equal to or less than $1.31 \times 10^{-2} \times f^{0.6834}$ W (adjusted for tune-up tolerance), where f is in MHz.

Results: Compliant

Frequency	Separation Distance	Maximum Power ¹		RSS-102 Exemption Limit ²	Result
		(mW)	(Watts)	(Watts)	
912.00	≥ 20	8.53	0.00853	1.38	Compliant
920.00	≥ 20	8.18	0.00818	1.39	Compliant

¹ Reference Section 6.2 of this report.

² Reference RSS-102, § 2.5.2 Exemption Limits for Routine Evaluation – RF Exposure Evaluation for distances greater than 20 cm.

The following formula was used to determine the exemption limit (W):

$$1.31 \times 10^{-2} \times f^{0.6834} \quad (f = \text{frequency (MHz)})$$

8. Test Setup Photographs

8.1. Spurious Radiated Emissions, 30 kHz to 30 MHz – Front



8. Test Setup Photographs

8.2. Spurious Radiated Emissions, < 30 MHz – Rear



8. Test Setup Photographs

8.3. Spurious Radiated Emissions, 30 MHz to 1 GHz – Rear View



8. Test Setup Photographs

8.4. Radiated Emissions Above 1 GHz – Front

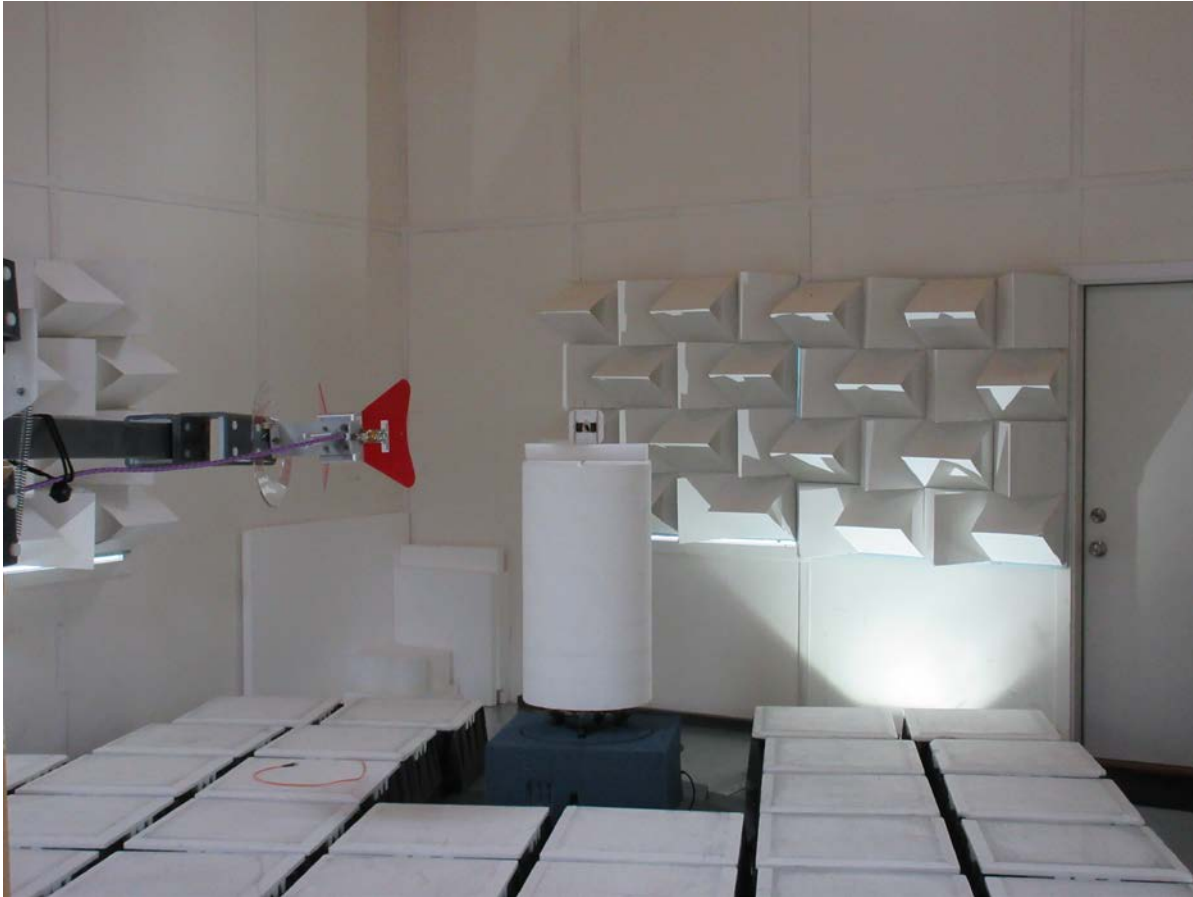

8. Test Setup Photographs

8.5. Radiated Emissions 1 to 18 GHz – Rear



8. Test Setup Photographs

8.6. Radiated Emissions Above 18 GHz – Rear



8. Test Setup Photographs

8.7. Conducted Emissions Measurements - Front



8. Test Setup Photographs

8.8. Conducted Emissions Measurements - Rear



9. Test Site Description

Compliance Worldwide is located at 357 Main Street in Sandown, New Hampshire. The test sites at Compliance Worldwide are used for conducted and radiated emissions testing in accordance with the Federal Communications Commission (FCC) and Innovation Science and Economic Development Canada (ISED) standards. Through our American Association for Laboratory Accreditation (A2LA) ISO Guide 17025 Accreditation our test sites are designated with the FCC (designation number **US1091**), Industry Canada (file number **IC 3023A-1**) and VCCI (Member number 3168) under registration number A-0274.

Compliance Worldwide is also designated as a Phase 1 CAB under APEC-MRA (US0132) for Australia/New Zealand AS/NZS CISPR 22, Chinese-Taipei (Taiwan) BSMI CNS 13438 and Korea (RRA) KN 11, KN 13, KN 14-1, KN 22, KN 32, KN 61000-6-3, KN 61000-6-4.

The radiated emissions test site is a 3 and 10 meter enclosed open area test site (OATS). Personnel, support equipment and test equipment are located in the basement beneath the OATS ground plane.

The conducted emissions site is part of a 16' x 20' x 12' ferrite tile chamber and uses one of the walls for the vertical ground plane required by EN 55022. A second conducted emissions site is also located in the basement of the OATS site with a 2.3 x 2.5 meter ground plane and a 2.4 x 2.4 meter vertical wall.

The radiated emissions test site for measurements above 1GHz is a 3 Meter open area test site (OATS) with a 3.6 by 3.6 meter anechoic absorber floor patch to achieve a quasi-free space measurement environment per ANSI C63.4/C63.10 and CISPR 16-1-4 standards.

The sites are designed to test products or systems 1.5 meters W x 1.5 meters L x 2.0 meters H, floor standing or table top.

Appendix A - Transmitter Spurious Radiated Emissions (30 kHz to 9.4 GHz)

A1. Spurious Radiated Emissions (30 kHz – 150 kHz) Test Results

A1.1. Low Channel 912 MHz

A1.1.1. Measurement Results: Parallel Antenna

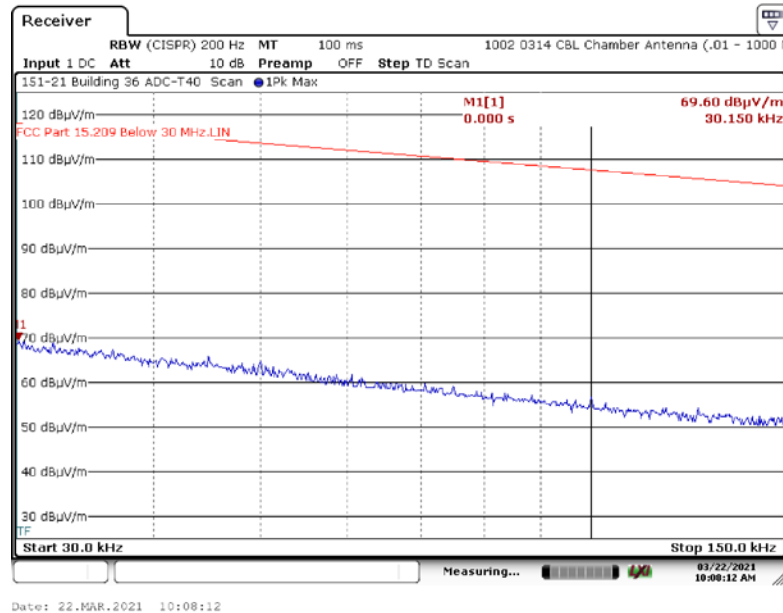

A1.1.2. Measurement Results: Perpendicular Antenna

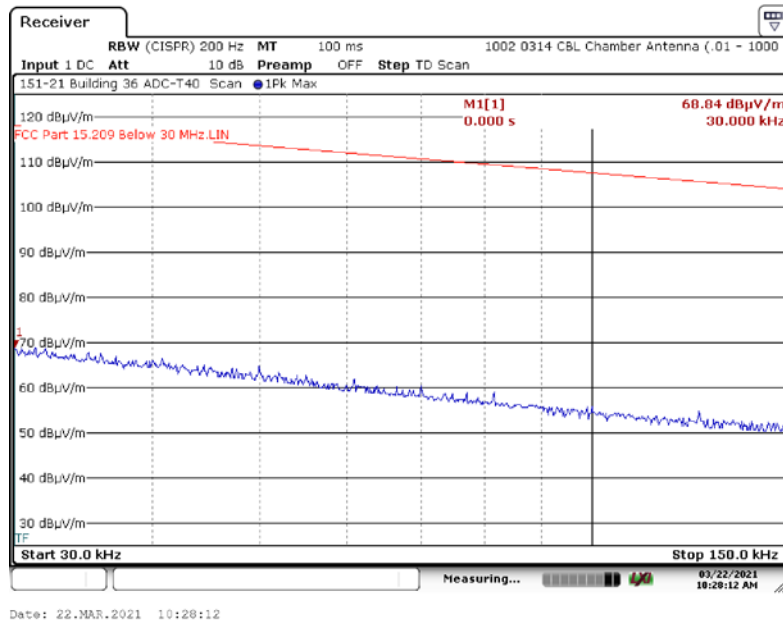

Appendix A - Transmitter Spurious Radiated Emissions (30 kHz to 9.4 GHz)

A1. Spurious Radiated Emissions (30 kHz – 150 kHz) Test Results

A1.1. Low Channel, 912 MHz

A1.1.3. Measurement Results: Ground-Parallel Antenna

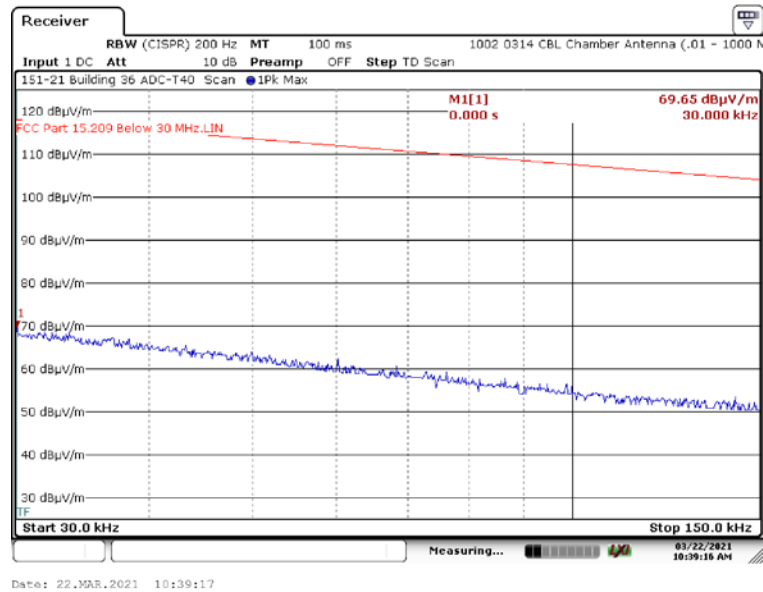

A1.2. High Channel, 920 MHz

A1.2.1. Measurement Results: Parallel Antenna

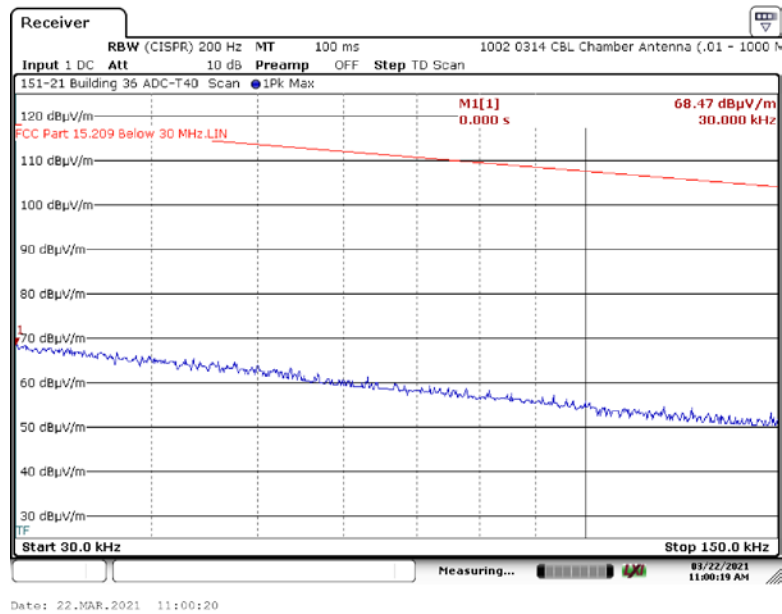

Appendix A - Transmitter Spurious Radiated Emissions (30 kHz to 9.4 GHz)

A1. Spurious Radiated Emissions (30 kHz – 150 kHz) Test Results

A1.2. High Channel, 920 MHz

A1.2.2. Measurement Results: Perpendicular Antenna

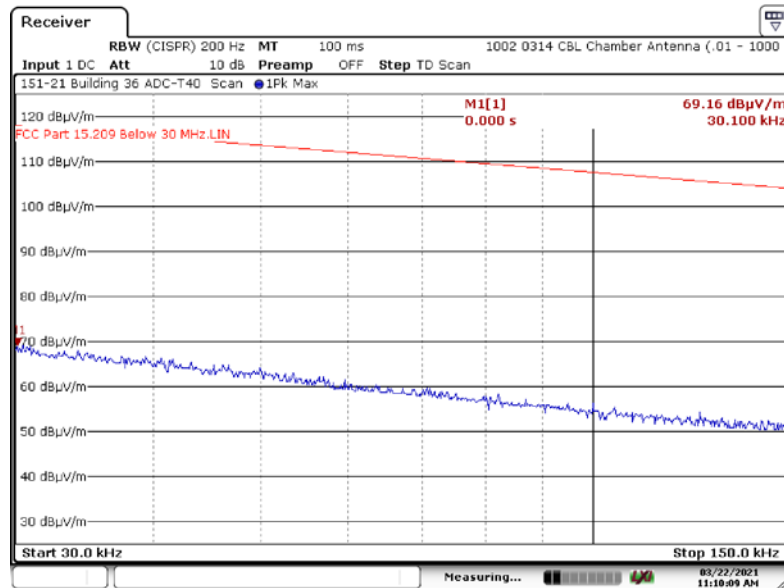

Date: 22.MAR.2021 11:10:10

A1.2. High Channel, 920 MHz

A1.2.3. Measurement Results: Ground-Parallel Antenna

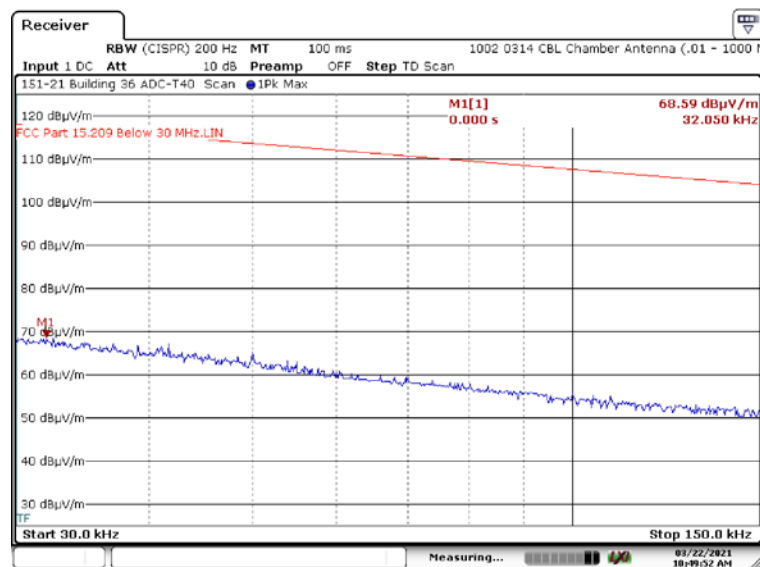

Date: 22.MAR.2021 10:49:52

Appendix A - Transmitter Spurious Radiated Emissions (30 kHz to 9.4 GHz)

A2. Spurious Radiated Emissions (150 kHz – 30 MHz) Test Results

A2.1. Low Channel, 912 MHz

A2.1.1. Measurement Results: Parallel Antenna

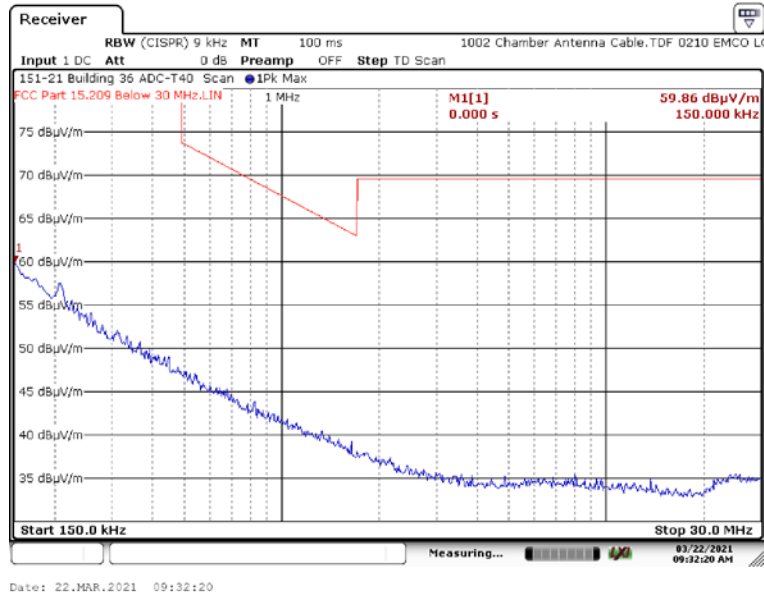

A2.1.2. Measurement Results: Perpendicular Antenna

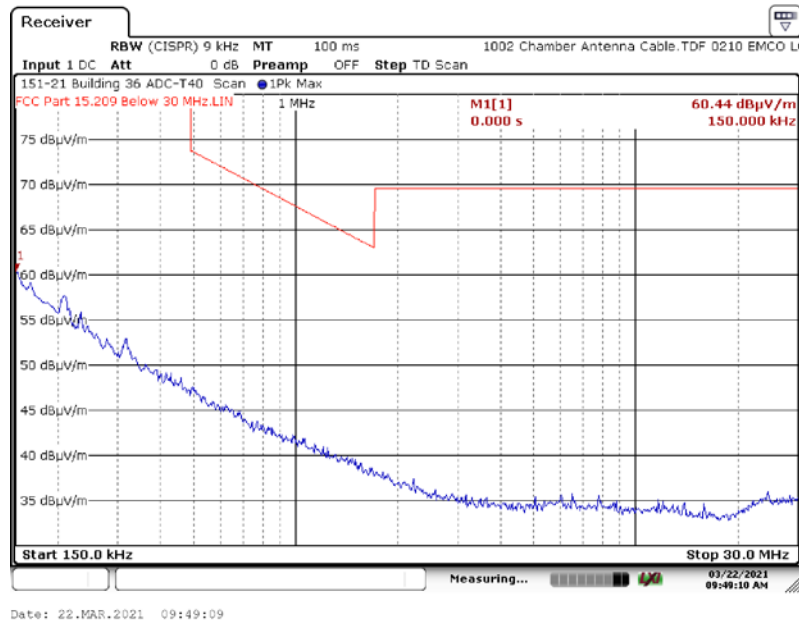

Appendix A - Transmitter Spurious Radiated Emissions (30 kHz to 9.4 GHz)

A2. Spurious Radiated Emissions (150 kHz – 30 MHz) Test Results

A2.1. Low Channel, 912 MHz

A2.1.3. Measurement Results: Ground-Parallel Antenna

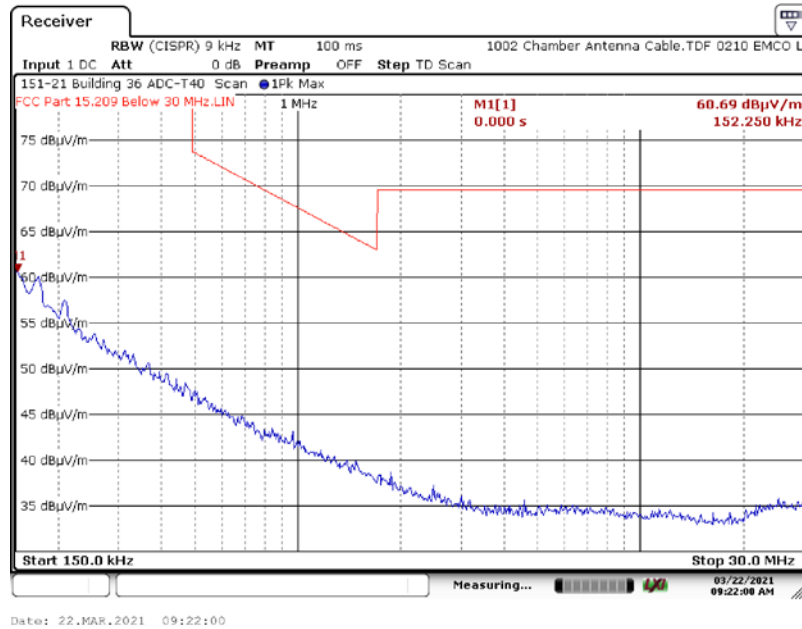

A2.2. High Channel, 920 MHz

A2.2.1. Measurement Results: Parallel Antenna

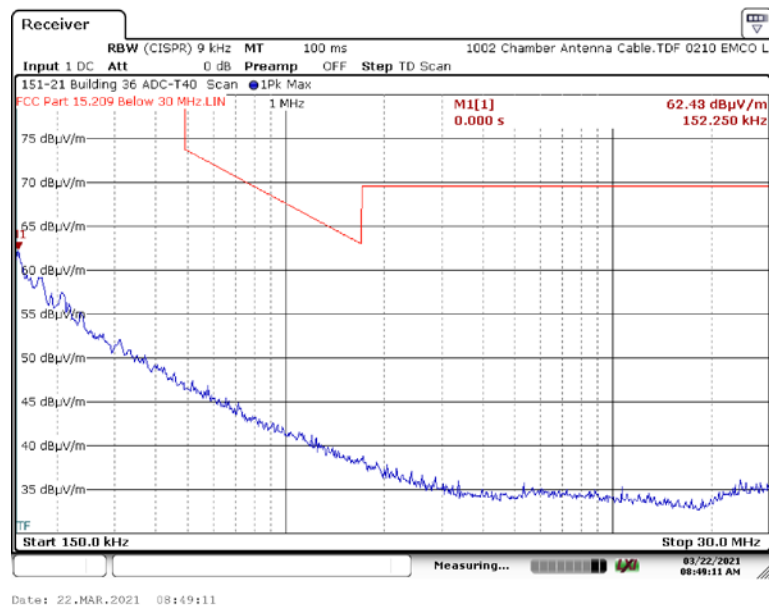

Appendix A - Transmitter Spurious Radiated Emissions (30 kHz to 9.4 GHz)

A2. Spurious Radiated Emissions (150 kHz – 30 MHz) Test Results

A2.2.2. Measurement Results: Perpendicular Antenna

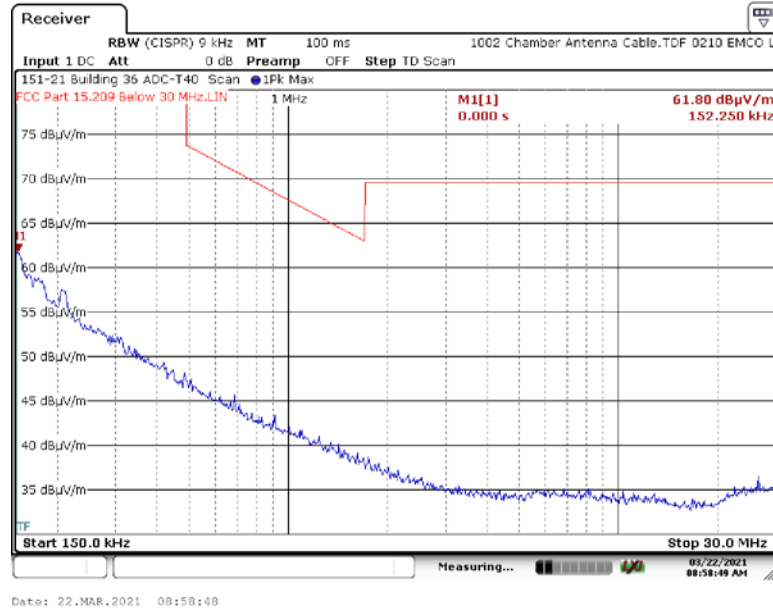

A2.2. High Channel, 920 MHz

A2.2.3. Measurement Results: Ground-Parallel Antenna

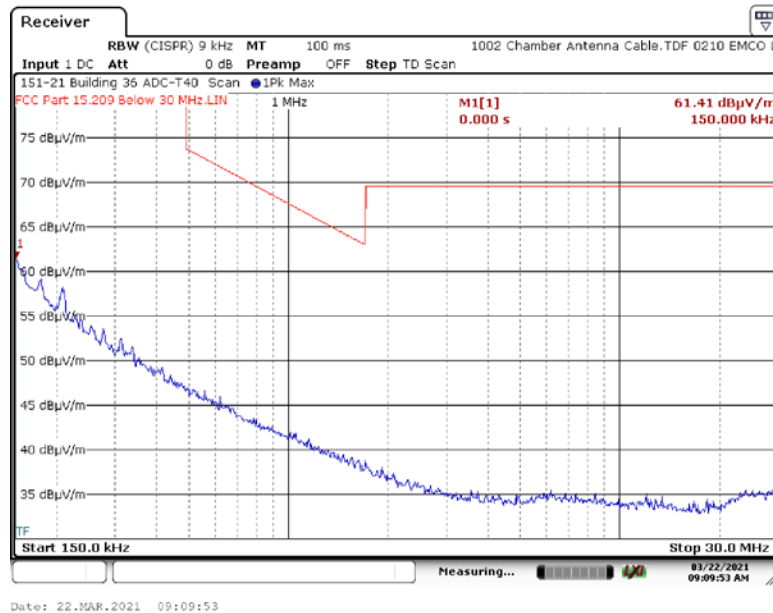

Appendix A - Transmitter Spurious Radiated Emissions (30 kHz to 9.4 GHz)

A3. Spurious Radiated Emissions (30 MHz – 1 GHz) Test Results

A3.1. Low Channel, 912 MHz

A3.1.1. Measurement Results: Horizontal Antenna

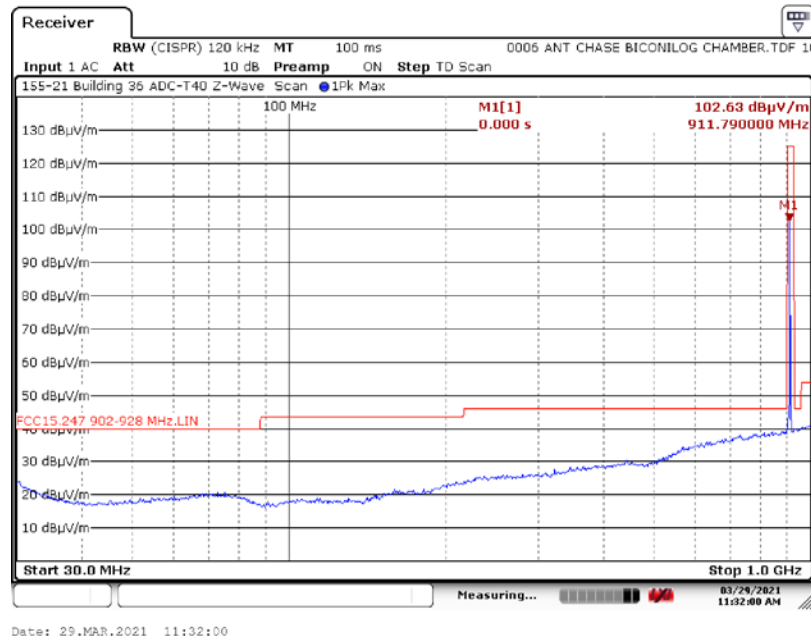

A3.1.2. Measurement Results: Vertical Antenna

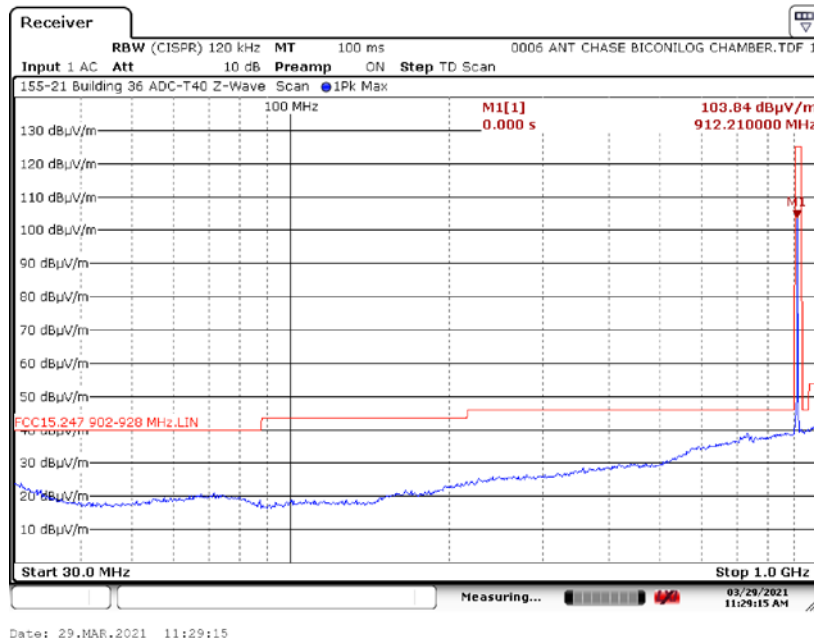

Appendix A - Transmitter Spurious Radiated Emissions (30 kHz to 9.4 GHz)

A3. Spurious Radiated Emissions (30 MHz – 1 GHz) Test Results

A3.2. High Channel, 920 MHz

A3.2.1. Measurement Results: Horizontal Antenna

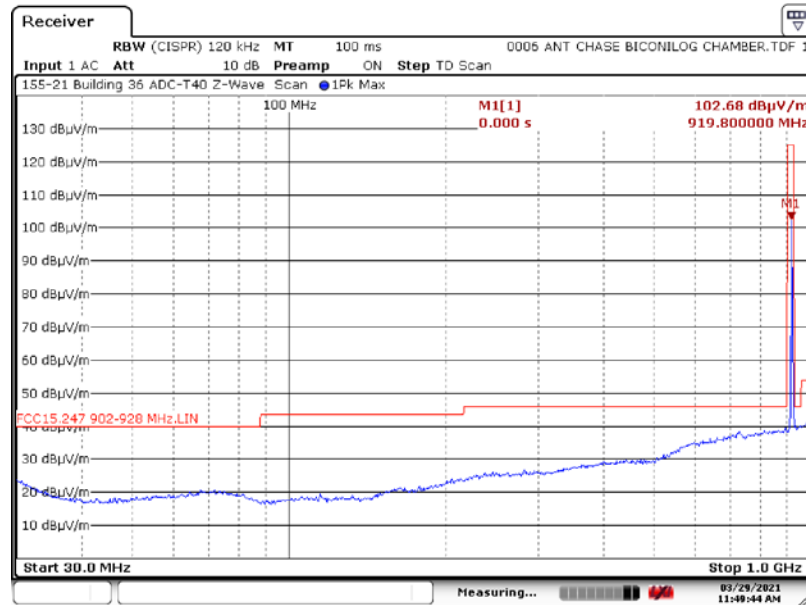

Date: 29.MAR.2021 11:49:44

A3.2.2. Measurement Results: Vertical Antenna

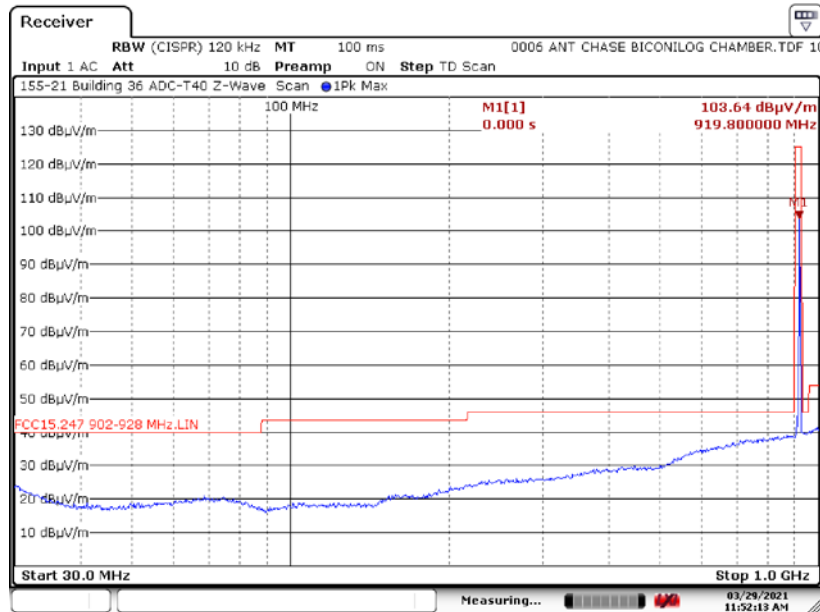

Date: 29.MAR.2021 11:52:13

Appendix A - Transmitter Spurious Radiated Emissions (30 kHz to 9.4 GHz)

A4. Spurious Radiated Emissions (1 GHz – 9.4 GHz) Test Results

A4.1. Low Channel, 912 MHz

A4.1.1. Measurement Results: Horizontal Antenna

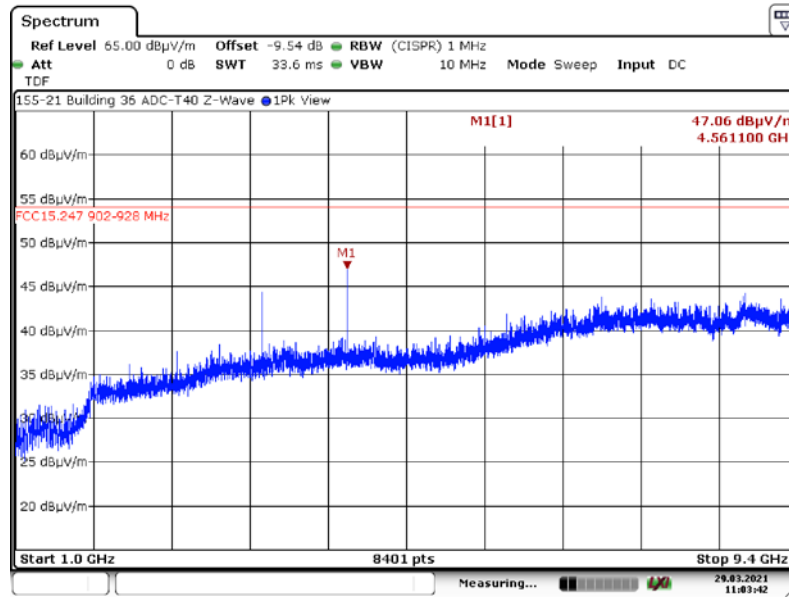

A4.1.2. Measurement Results: Vertical Antenna

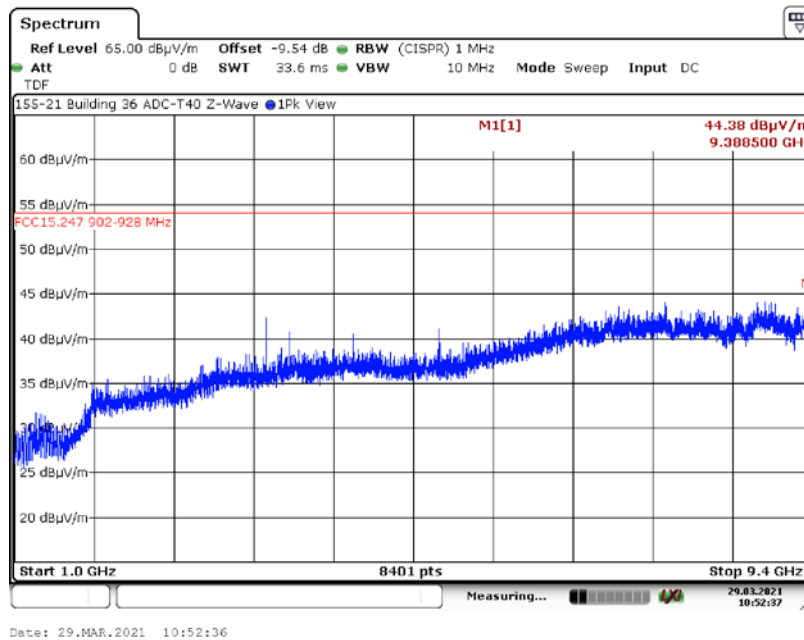

Appendix A - Transmitter Spurious Radiated Emissions (30 kHz to 9.4 GHz)

A4. Spurious Radiated Emissions 1 GHz – 9.4 GHz) Test Results

A4.2. High Channel, 920 MHz

A4.2.1. Measurement Results: Horizontal Antenna

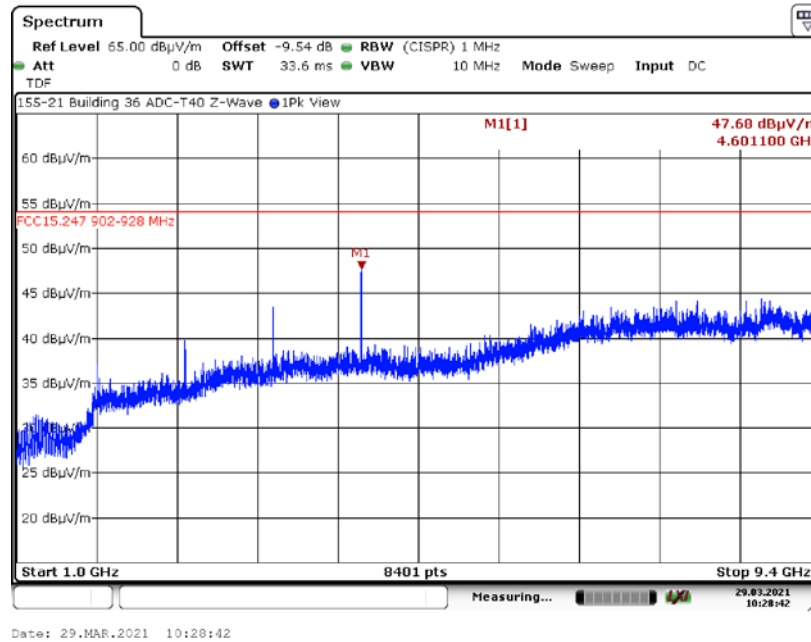

A4.2.2. Measurement Results: Vertical Antenna

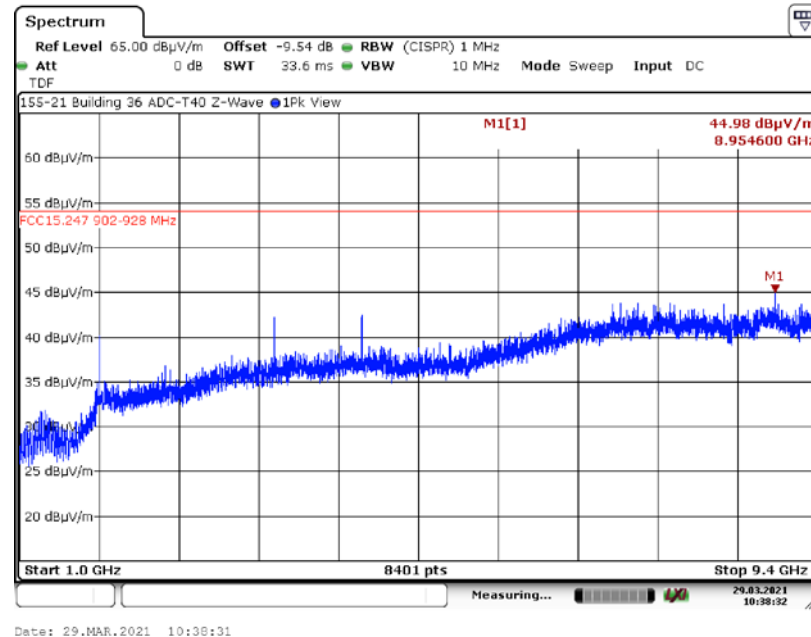

Appendix B

B1. Emissions in Non-restricted Frequency Bands (30 MHz to 9.28 GHz)

B1.1. Emissions in Non-restricted Frequency Bands (30 MHz – 9.28 GHz) Test Results

B1.1.1. Measurement Results, 912 MHz, 30 MHz – 902 MHz

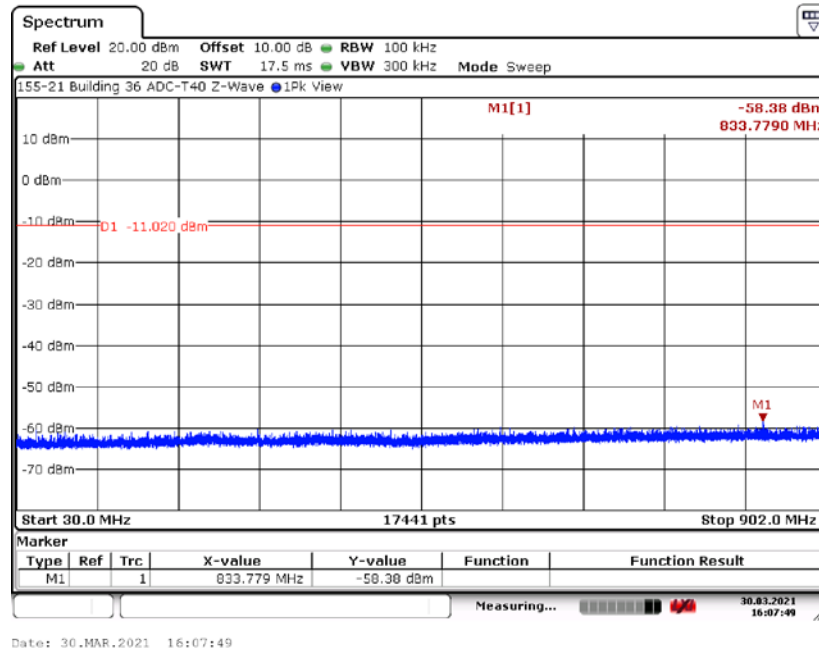

B1.1.2. Measurement Results, 912 MHz: 928 MHz – 9.28 GHz

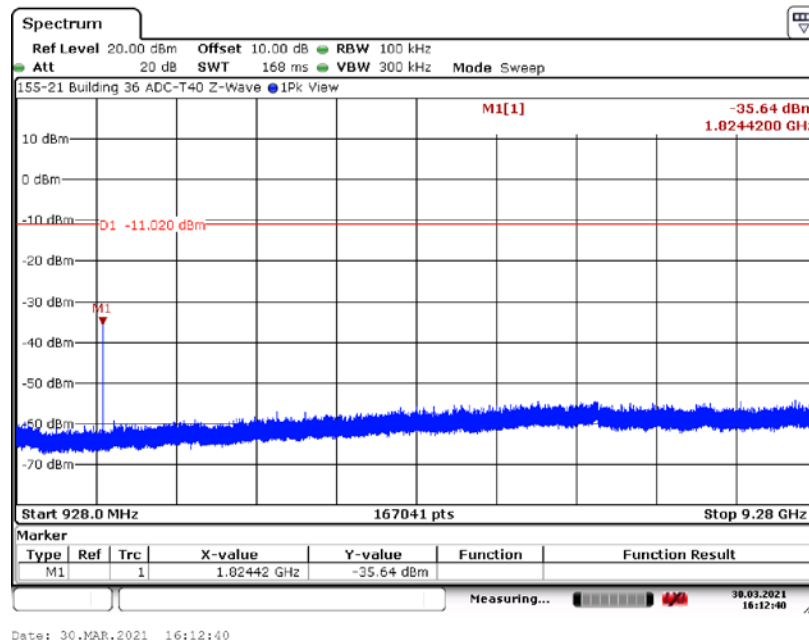

Appendix B

B1. Emissions in Non-restricted Frequency Bands (30 MHz to 9.28 GHz) (continued)

B1.1. Emissions in Non-restricted Frequency Bands (30 MHz – 9.28 GHz) Test Results

B1.2.1. Measurement Results, 920 MHz, 30 MHz – 902 GHz

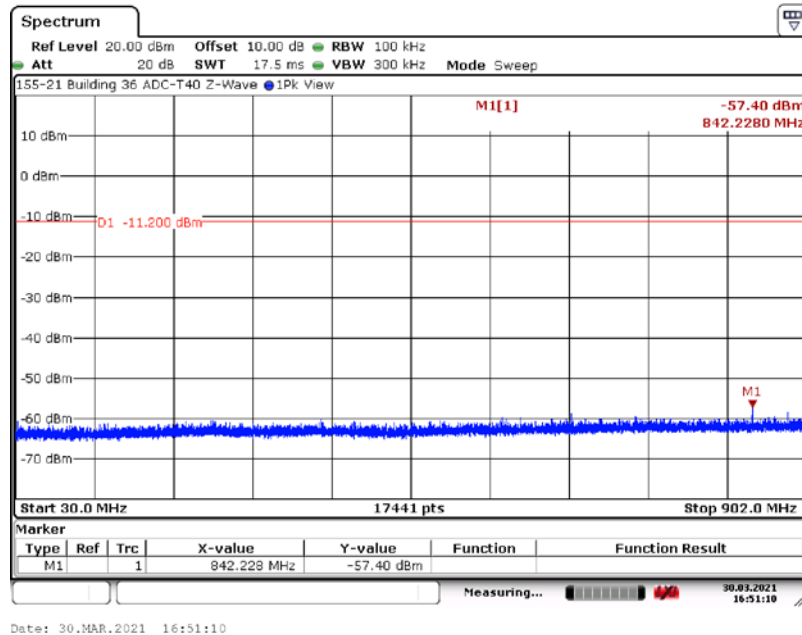

B1.2.2. Measurement Results, 920 MHz, 928 MHz – 9.28 GHz

