



# **Dry Contact Sensor**

## Installation Guide

ADC-S40-DC

## In the box

- ADC-S40-DC  
Dry Contact Sensor
- Mounting bracket
- CR123 battery
- Installation guide
- Screw (x2)
- Cable tie
- Double-sided tape

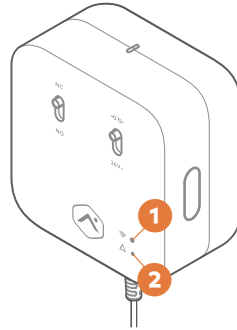

Dry Contact Sensor

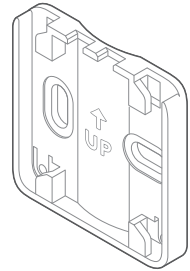

Mounting bracket

1 Network LED

2 Alert LED

## Switch Definitions

**NO:** Connected to a Normally Opened Circuit

**NC:** Connected to a Normally Closed Circuit

**24V:** Connected to a 24V Circuit

**-o-b-:** Connected to a non-powered circuit.

## Pre-installation checklist

### Installing the Dry Contact Sensor

- 1 Before you begin, turn off power to the equipment we are monitoring.
- 2 Identify the type of float switch for the HVAC unit in the "Wiring Diagrams" section.

## Wiring diagrams

### Monitoring the R-wire with float switches wired between the HVAC control board and the thermostat

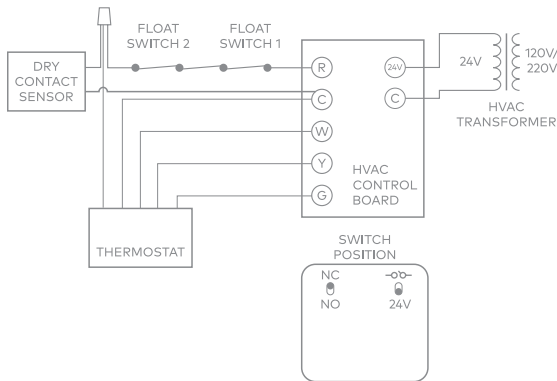

- 1 Turn off power to the HVAC unit.
- 2 Install or locate the existing float switches.

- 3 Connect one Dry Contact Sensor wire to the float switch wire that goes to the thermostat.

*NOTE: If the unit has more than one float switch, ensure the Dry Contact Sensor connects to the last float switch in the series.*

- 4 Connect the remaining Dry Contact Sensor wire to the C terminal on the HVAC control board.
- 5 The switches on the front of the Dry Contact Sensor should be set to NC (black) and 24V (orange).
- 6 Remove the battery tab from the Dry Contact Sensor.
- 7 Using the screws, double-sided adhesive tape, or cable tie provided, install the mounting bracket to a wall or pipe near the desired monitoring area, and then mount the Dry Contact Sensor.
- 8 Turn on power to the HVAC unit. If the LEDs are blinking in a pattern, that means the switches are configured incorrectly. Please double check the wiring and switch positions before testing the unit.
- 9 Test the operation of the Dry Contact Sensor by tripping the float sensor and holding it in that position for approximately two seconds. Ensure the Alert LED on the Dry Contact Sensor turns on for 3 seconds. If the sensor remains in the alert state, it will continue to blink for 5 minutes.

## Monitoring the R-wire with float switches wired between the HVAC transformer and the HVAC control board

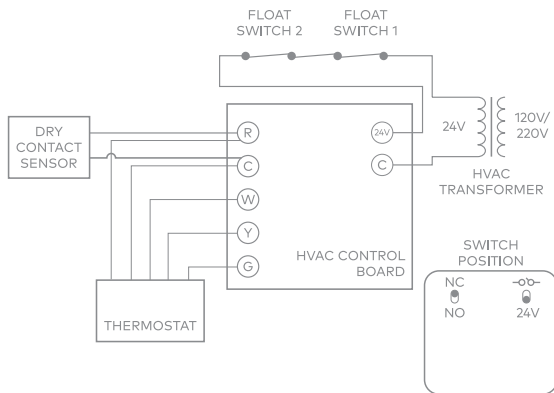

- 1 Turn off power to the HVAC unit.
- 2 Connect one Dry Contact Sensor wire to the R terminal on the HVAC control board.

*Continued next page →*

- 3 Connect the remaining Dry Contact Sensor wire to the C terminal on the HVAC control board.
- 4 The switches on the front of the Dry Contact Sensor should be set to NC (black) and 24V (orange).
- 5 Remove the battery tab from the Dry Contact Sensor.
- 6 Using the screws, double-sided adhesive tape, or cable tie provided, install the mounting bracket to a wall or pipe near the desired monitoring area, and then mount the Dry Contact Sensor.
- 7 Turn on power to the HVAC unit. If the LEDs are blinking in a pattern, that means the switches are configured incorrectly. Please double check the wiring and switch positions before testing the unit.
- 8 Test the operation of the Dry Contact Sensor by tripping the float sensor and holding it in that position for approximately two seconds. Make sure the Alert LED on the Dry Contact Sensor turns on for 3 seconds. If the sensor remains in the alert state, it will continue to blink for 5 minutes.

## Monitoring float switches with a dedicated alarm circuit

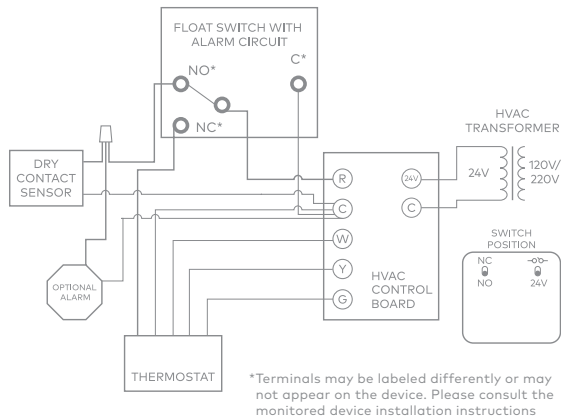

- 1 Turn off power to the HVAC unit.
- 2 Install or locate the existing switch with an alarm circuit.

Continued next page →

- 3 Connect one Dry Contact Sensor wire to the Normally Opened wire or terminal on the float switch
- 4 Connect the remaining Dry Contact Sensor wire to the C terminal on the HVAC control board.
- 5 The switches on the front of the Dry Contact Sensor should be set to NO (white) and 24V (orange).
- 6 Remove the battery tab from the Dry Contact Sensor.
- 7 Using the screws, double-sided adhesive tape, or cable tie provided, install the mounting bracket to a wall or pipe near the desired monitoring area, and then mount the Dry Contact Sensor.
- 8 Turn on power to the HVAC unit. If the LEDs are blinking in a pattern, that means the switches are configured incorrectly. Please double check the wiring and switch positions before testing the unit.
- 9 Test the operation of the Dry Contact Sensor by tripping the float sensor and holding it in that position for approximately two seconds. Make sure the Alert LED on the Dry Contact Sensor turns on for 3 seconds. If the sensor remains in the alert state, it will continue to blink for 5 minutes

## Monitoring Normally Open or Closed Dry Circuit (with no power running)

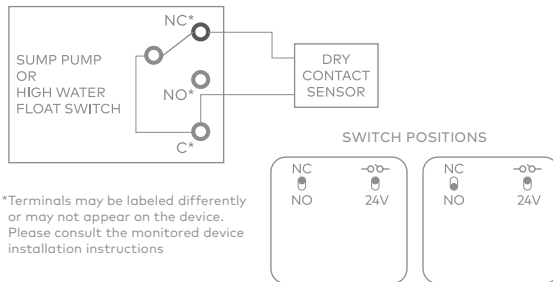

- 1 Connect the wires to the dry circuit you want to monitor.
- 2 The switches on the front of the Dry Contact Sensor should be set to NC (black) and -o-b- (purple) or NO (white) and -o-b- (purple).
- 3 Remove the battery tab from the Dry Contact Sensor
- 4 Using the screws, double-sided adhesive tape, or cable tie provided, install the mounting bracket to a wall or pipe near the desired monitoring area, and then mount the Dry Contact Sensor.

- 5 If the LEDs are blinking in a pattern, that means the switches are configured incorrectly. Please double check the wiring and switch positions before testing the unit.
- 6 Test the operation of the Dry Contact Sensor by placing the sump pump in alert state for approximately two seconds. Make sure the Alert LED on the Dry Contact Sensor turns on for 3 seconds. If the sensor remains in the alert state, it will continue to blink for 5 minutes.

## Add the sensor to the Z-Wave network

### Connect to the network using Z-Wave SmartStart

*NOTE: An Alarm.com account is required for this process. Power on and add devices one at a time.*

- 1 Power on the Hub.
- 2 Log in to the MobileTech app and find the customer account.
- 3 Add the device using SmartStart and follow the on-screen instructions.

- 4 Scan the device's QR code found on the box or sensor.
- 5 Press the button on the sensor. (You will need to remove the battery tab if you have not already done so.)
  - *When the network LED on the sensor turns solid green, the sensor has been successfully added.*
- 6 Ensure you see the device on your account. This may take up to 2 minutes.

### Connect to the network manually

*TIP: For best results, we recommend having the Hub in the same room as the dry contact sensor you are adding.*

- 1 Remove the battery tab from the sensor.
- 2 Put the Hub into Add mode. Refer to the Hub documentation for more information.
- 3 Press the button on the sensor to add the device to the network. When the network LED on the sensor turns solid green, the sensor has been successfully added.
- 4 Name the device based on its application. This can be done on MobileTech, the Partner Portal, or the Customer Website.

# Troubleshooting

## If the Dry Contact Sensor is not communicating with the Hub

- 1 Press the button on the sensor. The network LED should turn on and then turn off within a few seconds. If this does not happen, the Dry Contact Sensor cannot communicate with the Hub. Follow these steps to fix the communication problems:

- a) Install a Z-Wave repeater between the Hub and Dry Contact Sensor.

*TIP: Any AC-powered Z-Wave device will act as a Repeater and improve the range between the Hub and the Z-Wave device you are installing.*

- b) If the previous step does not resolve the issue, try deleting the sensor from the network (see next section) and add it again.

## Deleting the sensor from the network

*TIP: For best results, we recommend having the Hub in the same room as the Dry Contact Sensor.*

- 1 Put the Hub into Delete mode. Refer to the Hub documentation for more information.
  - 2 Press the button on the sensor to delete it from the network. The network LED on the sensor will turn solid green and then blink to indicate the device has been successfully deleted.
- The network LED on the sensor will turn solid green and then blink to indicate the device has been successfully deleted.



## Notices

### FCC

This device complies with part 15 of the FCC rules. Operation is subject to the following two conditions:

1. This device may not cause harmful interference, and
2. This device must accept any interference received, including interference that may cause undesired operation.

NOTE: Changes and Modifications not expressly approved by Building 36 can void your authority to operate this equipment under Federal Communications Commissions rules.

This equipment has been tested and found to comply with the limits for a Class B digital device, pursuant to part 15 of the FCC Rules. These limits are designed to provide reasonable protection against harmful interference in a residential installation. This equipment generates, uses and can radiate radio frequency energy and, if not installed and used in accordance with the instruction, may cause harmful interference to radio communication. However, there is no guarantee that interference will not occur in a particular installation. If this equipment does cause harmful interference to radio or television reception, which can be determined by turning the equipment off and on, the user is encouraged to try to correct the interference by one or more of the following measures:

- Reorient or relocate the receiving antenna.
- Increase the separation between the equipment and receiver.
- Connect the equipment into an outlet on a circuit different from that to which the receiver is connected.
- Consult the dealer or an experienced radio/TV technician for help.

### IC Notice

This device complies with Industry Canada license-exempt RSS standard(s). Operation is subject to the following two conditions:

1. This device may not cause interference, and
2. This device must accept any interference received, including interference that may cause undesired operation.

Le present appareil est conforme aux CNR d'Industrie Canada applicables aux appareils radio exempts de licence. L'exploitation est autorisee aux deux conditions suivantes:

1. L'appareil ne doit pas produire de brouillage, et
2. L'appareil doit accepter tout brouillage radioelectrique subi, meme si le brouillage est susceptible d'en compromettre le fonctionnement.

## Radiation Exposure Statement

The device has been found to be compliant to the requirements set forth in CFR 47 Sections 2.1091 and Industry Canada RSS-102 for an uncontrolled environment. The antenna(s) used for this transmitter must be installed to provide a separation distance of at least 20 cm from all persons and must not be co-located or operating in conjunction with any other antenna or transmitter.

Le dispositif a été jugé conforme aux exigences énoncées dans les articles 47 CFR 2.1091 et Industrie Canada RSS-102 pour un environnement non contrôlé. L'antenne(s) utilisée pour ce transmetteur doit être installée pour fournir une distance de séparation d'au moins 20 cm de toutes les personnes et ne doit pas être co-localisée ou fonctionner en conjonction avec une autre antenne ou transmetteur.

## Questions?

Visit [answers.alarm.com](https://www.answers.alarm.com)  
or contact your service provider.



8281 Greensboro Drive  
Suite 100  
Tysons, VA 22102

220111  
© 2022 Alarm.com.  
All rights reserved.