



FCC TEST REPORT

According to

CFR47 §15.247

Applicant	:	NINGBO DIYA ELECTRIC APPLIANCE CO.,LTD.
Address	:	SIMEN TOWN YUYAO CITY ZHEJIANG CHINA
Manufacturer	:	NINGBO DIYA ELECTRIC APPLIANCE CO.,LTD.
Address	:	SIMEN TOWN YUYAO CITY ZHEJIANG CHINA
Equipment	:	Remote Control Socket
Model No.	:	DR-1703
FCC ID	:	2AC2CDR-017
Test Period	:	Jun.07th,2018~ Sep.03th, 2018

- The test result refers exclusively to the test presented test model / sample.
- Without written approval of **Cerpass Technology Corporation Test Laboratory** the test report shall not be reproduced except in full.
- The test report must not be used by the clients to claim product certification approval by any agency of the Government.

I HEREBY CERTIFY THAT :

The measurements shown in this test report were made in accordance with the procedures given in **ANSI C63.10 – 2013& FCC Part15.247** and the energy emitted by this equipment was **passed**.

Approved by:

Laboratory Accreditation:

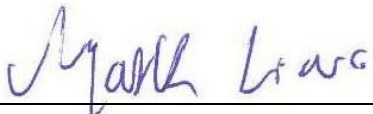

Mark Liao / Assistant Manager



Cerpass Technology Corporation Test Laboratory

TAF LAB Code:**1439**



Contents

1. Report of Measurements and Examinations	5
2. General Info	6
2.1 Description of EUT	6
2.2 Description of wireless module	7
2.3 Description of Antenna	7
2.4 Carrier Frequency of Channels	8
2.5 The Worst Case Configuration	8
2.6 EUT Exercise Software	8
2.7 Power Parameter Value of the test software	9
2.8 Duty cycle	10
2.9 Support equipment	11
3. General Information of Test Site	12
3.1 Information of Test Site	12
3.2 Measuring Equipment	13
3.3 Measurement Uncertainty	14
4. AC Conducted Emission Measurement	15
4.1 Test Limit	15
4.2 Test Standard	15
4.3 Test Procedures	15
4.4 Test Setup Layout	16
4.5 Test Result	17
5. Radiated Emission Measurement	19
5.1 Test Limit	19
5.2 Test Standard	19
5.3 Test Procedures	20
5.4 Test Setup Layout	21
5.5 Test Result	23
6. 6dB Bandwidth Measurement	30
6.1 Test Limit	30
6.2 Test Standard	30
6.3 Test Procedures	30
6.4 Test Setup Layout	30
6.5 Test Result	31
7. Output Power Measurement	34
7.1 Test Limit	34
7.2 Test Standard	34
7.3 Test Procedures	34
7.4 Test Setup Layout	34
7.5 Test Result	35
8. Power Spectral Density Measurement	36
8.1 Test Limit	36
8.2 Test Standard	36
8.3 Test Procedures	36



8.4 Test Setup Layout 36

8.5 Test Result 37

9. Conducted Band Edge and Out-of-Band Emissions Measurement 41

9.1 Test Limit 41

9.2 Test Standard 41

9.3 Test Procedures 42

9.4 Test Setup Layout 42

9.5 Test Result 43

10. Radiated Emission Band Edge Measurement 50

10.1 Test Limit 50

10.2 Test Standard 50

10.3 Test Procedure 50

10.4 Test Setup Layout 51

10.5 Test Result 52



History of this Test Report

Report No.	Version	Issue Date	Description
TEF1806021	Rev 01	Sep.03 2018	Original.



1. Report of Measurements and Examinations

Performed Test Item	Normative References	Test Performed	Deviation	Result
Conducted Emission	FCC CFR Title 47 Part 15 Subpart C: 2014 Section 15.207 RSS-GEN Issue 4 Section 8.8	Yes	N/A	Pass
Radiated Emission	FCC CFR Title 47 Part 15 Subpart C: 2014 Section 15.209 RSS-Gen Issue 4 November 2014 Section 6.13	Yes	No	Pass
RF Antenna Conducted Spurious	FCC CFR Title 47 Part 15 Subpart C: 2014 Section 15.247(d) RSS-247 Issue 2 February 2017 Section 5.5	Yes	No	Pass
Radiated Emission Band Edge	FCC CFR Title 47 Part 15 Subpart C: 2014 15.247(d) RSS-247 Issue 2 February 2017 Section 5.5	Yes	No	Pass
Operation Frequency Range of 20dB Bandwidth	FCC CFR Title 47 Part 15 Subpart C: 2014 15.215(c)	Yes	No	Pass
Occupied Bandwidth	FCC CFR Title 47 Part 15 Subpart C: 2014 Section 15.247(a)(2) RSS-247 Issue 2 February 2017 Section 5.1(a)	Yes	No	Pass
Output Power	FCC CFR Title 47 Part 15 Subpart C: 2014 Section 15.247(b)(3) RSS-247 Issue 2 February 2017 Section 5.1(b)	Yes	No	Pass
Power Spectral Density	FCC CFR Title 47 Part 15 Subpart C: 2014 Section 15.247(e) RSS-247 Issue 2 February 2017 Section 5.2(b)	Yes	No	Pass



2. General Info

2.1 Description of EUT

Product name	Remote Control Socket
Model No.	DR-1703



2.2 Description of wireless module

WLAN	TYWE3S
Spreading	802.11b: CCK, DQPSK, DBPSK 802.11g: 64 QAM, 16 QAM, QPSK, BPSK 802.11n: BPSK, QPSK, 16-QAM, 64-QAM
Frequency Range	802.11b/g/n(20MHz): 2412-2462MHz
Number of Channels	802.11b/g/n (20MHz):11
Data Rate	802.11b: 1, 2, 5.5, 11Mbps 802.11g: 6, 9, 12, 18, 24, 36, 48, 54Mbps 802.11n: MCS0~MCS7

Note: For more details, please refer to the EUT User manual.

2.3 Description of Antenna

Antenna	Peak Gain
PCB Antenna	3dBi for 2.40~2.50GHz band



2.4 Carrier Frequency of Channels

802.11b, 802.11g, 802.11n(20MHz)			
Channel	Frequency(MHz)	Channel	Frequency(MHz)
01	2412	08	2447
02	2417	09	2452
03	2422	10	2457
04	2427	11	2462
05	2432		
06	2437		
07	2442	---	---

2.5 The Worst Case Configuration

Data rate Configuration:

Modulation Mode	Worst Data Rate
802.11b	1Mbps
802.11g	6Mbps
802.11n(HT20)	MCS0

Note: Power output test was verified over all data rates of each mode, and then choose the maximum power output for final test of each channel shown as the table.

2.6 EUT Exercise Software

1	Turn on the power of equipment.
2	Run 'SecureCRTPortable', input RF test command and set the test mode and channel, then press Transmit to start continue transmit.

**2.7 Power Parameter Value of the test software**

Mode	Frequency (MHz)	Power Setting
802.11b	2412	0
	2437	0
	2462	0
802.11g	2412	0
	2437	0
	2462	0
802.11n(20MHz)	2412	0
	2437	0
	2462	0



2.8 Duty cycle

Test Item	Duty cycle
-----------	------------

Mode	Frequency (MHz)	Measurement (%)
802.11b	2412	88.8
802.11g	2412	80.7
802.11n(20MHz)	2412	84.6





2.9 Support equipment

Product	Manufacturer	Model No.	Serial No.	Power Cord
N/A	N/A	N/A	N/A	N/A

Connection Diagram	
	
Signal Cable Type	Signal cable Description
A N/A	N/A



3. General Information of Test Site

3.1 Information of Test Site

Test Site :	Cerpass Technology Corporation Test Laboratory Address: No.10, Ln. 2, Lianfu St., Luzhu Dist., Taoyuan City 33848, Taiwan (R.O.C.) Tel:+886-3-3226-888 Fax:+886-3-3226-881 Address: No.68-1, Shihbachongsi, Shihding Township, New Taipei City 223, Taiwan, R.O.C. Tel: +886-2-2663-8582
FCC Registration Number :	TW1439
IC Registration Number :	4934B-1, 4934E-1, 4934E-2
VCCI	T-2205 for Telecommunication Test C-4663 for Conducted emission test R-3428, R-4218 for Radiated emission test G-812, G-813 for radiated disturbance above 1GHz
Frequency Range Investigated :	Conducted Emission Test: from 150 kHz to 30 MHz Radiated Emission Test: from 30 MHz to 18,000 MHz
Test Distance :	The test distance of radiated emission below 1GHz from antenna to EUT is 3 M. The test distance of radiated emission above 1GHz from antenna to EUT is 3 M.



3.2 Measuring Equipment

Instrument/Ancillary	Manufacturer	Model No.	Serial No.	Calibration Date	Valid Date.
EMI Receiver	R&S	ESCI3	100563	2018/06/21	2019/06/20
LISN	Schwarzbeck	NSLK 8127	8127-920	2017/11/08	2018/11/07
Pulse Limiter	R&S	ESH3-Z2	101933	2018/03/21	2019/03/20
Software	Farad	Ez-EMC	ver.ct3a1	N/A	N/A

Instrument/Ancillary	Manufacturer	Model No.	Serial No.	Calibration Date	Valid Date.
Loop Antenna	R&S	HFH2-Z2	100150	2017.11.02	2018.11.01
Bilog Antenna	Sunol	JB1	A072414-1	2018.07.07	2019.07.06
EMI Receiver	R&S	ESCI3	101183	2018.07.05	2019.07.04
EMI Receiver	R&S	ESCI7	100968	2018.07.30	2019.07.29
Preamplifier	EM Electronics corp.	EM330	60618	2018.03.21	2019.03.20
Horn Antenna	Schwarzbeck	BBHA9120 D	9120D-619	2018.07.07	2019.07.06
Horn Antenna	Schwarzbeck	BBHA9170	9170-348	2018.06.05	2019.06.04
Spectrum Analyzer	R&S	FSP40	100324	2018.08.23	2019.08.22
Preamplifier	EMCI	EMCI 030-00-3230	SN016723	2018.03.21	2019.03.20
Preamplifier	EM Electronics corp.	EM01G18G	SN060714	2018.06.01	2019.05.31
Spectrum Analyzer	KEYSIGHT	N9010A	MY53400169	2018.08.25	2019.08.24
Software	E3	AUDIX	Version: 8.14.806b	N/A	N/A



3.3 Measurement Uncertainty

ISO/IEC 17025 requires that an estimate of the measurement uncertainties associated with the emissions test results be included in the report. The measurement uncertainties given below are based on a 95% confidence level (based on a coverage factor (k=2)).

Measurement Item	Measurement Frequency	Polarization	Uncertainty
Conducted Emission	9 kHz ~ 30 MHz	Line / Neutral	± 2.9076 dB
Radiated Emission	9 kHz ~ 40,000 MHz	Vertical / Horizontal	± 0.948 dB
Spurious Emission (Conducted)	-	-	± 4.011 dB
Maximum Peak and Average Output Power	-	-	± 0.322 dB
Power Spectral Density	-	-	± 0.322 dB
Bandwidth	-	-	74.224Hz



4. AC Conducted Emission Measurement

4.1 Test Limit

Conducted Emissions were measured from 150 kHz to 30 MHz with a bandwidth of 9 KHz on the 120 VAC power and return leads of the EUT according to the methods defined in ANSI C63.10-2013 Section 6.2. The EUT was placed on a nonmetallic stand in a shielded room 0.8 meters above the ground plane as shown in section 6.2.2. The interface cables and equipment positioning were varied within limits of reasonable applications to determine the position produced maximum conducted emissions.

FCC Part 15 Subpart C Paragraph 15.207 Limits		
Frequency (MHz)	Quasi Peak (dB μ V)	Average (dB μ V)
0.15 – 0.5	66-56*	56-46*
0.5 – 5.0	56	46
5.0 – 30.0	60	50

*Decreases with the logarithm of the frequency.

4.2 Test Standard

Tested according to ANSI C63.10: 2013 Section 6.2 for compliance to FCC 47CFR 15.247 Part15.207 (a) requirements.

4.3 Test Procedures

The EUT was placed on a platform of nominal size, 1 m by 1.5 m, raised 80 cm above the conducting ground plane. The vertical conducting plane was located 40 cm to the rear of the EUT. All other surfaces of EUT were at least 80 cm from any other grounded conducting surface. The EUT and simulators are connected to the main power through a line impedance stabilization network (LISN). The LISN provides a 50 ohm /50uH coupling impedance for the measuring equipment. The peripheral devices are also connected to the main power through a LISN. (Please refer to the block diagram of the test setup and photographs) Each current-carrying conductor of the EUT power cord, except the ground (safety) conductor, was individually connected through a LISN to the input power source.

The excess length of the power cord between the EUT and the LISN receptacle were folded back and forth at the center of the lead to form a bundle not exceeding 40 cm in length.

Conducted emissions were investigated over the frequency range from 0.15MHz to 30MHz using a receiver bandwidth of 9 kHz.



4.4 Test Setup Layout

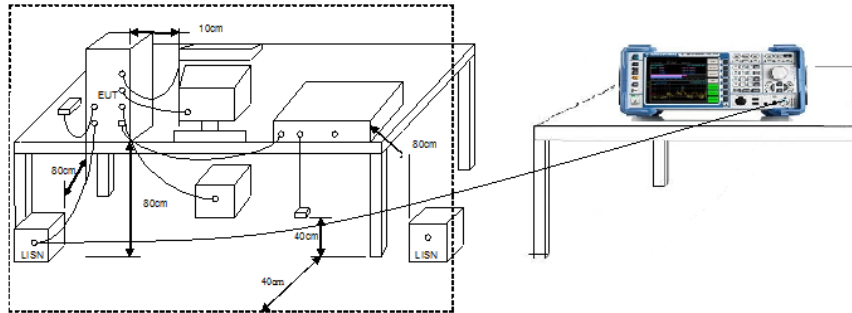



4.5 Test Result

Test Mode :	Mode 1: Normal Operation with WIFI on		
AC Power :	AC 120V/60Hz	Phase:	LINE
Temperature :	26°C	Humidity:	60%
Pressure(mbar) :	1002	Date:	2018/06/09

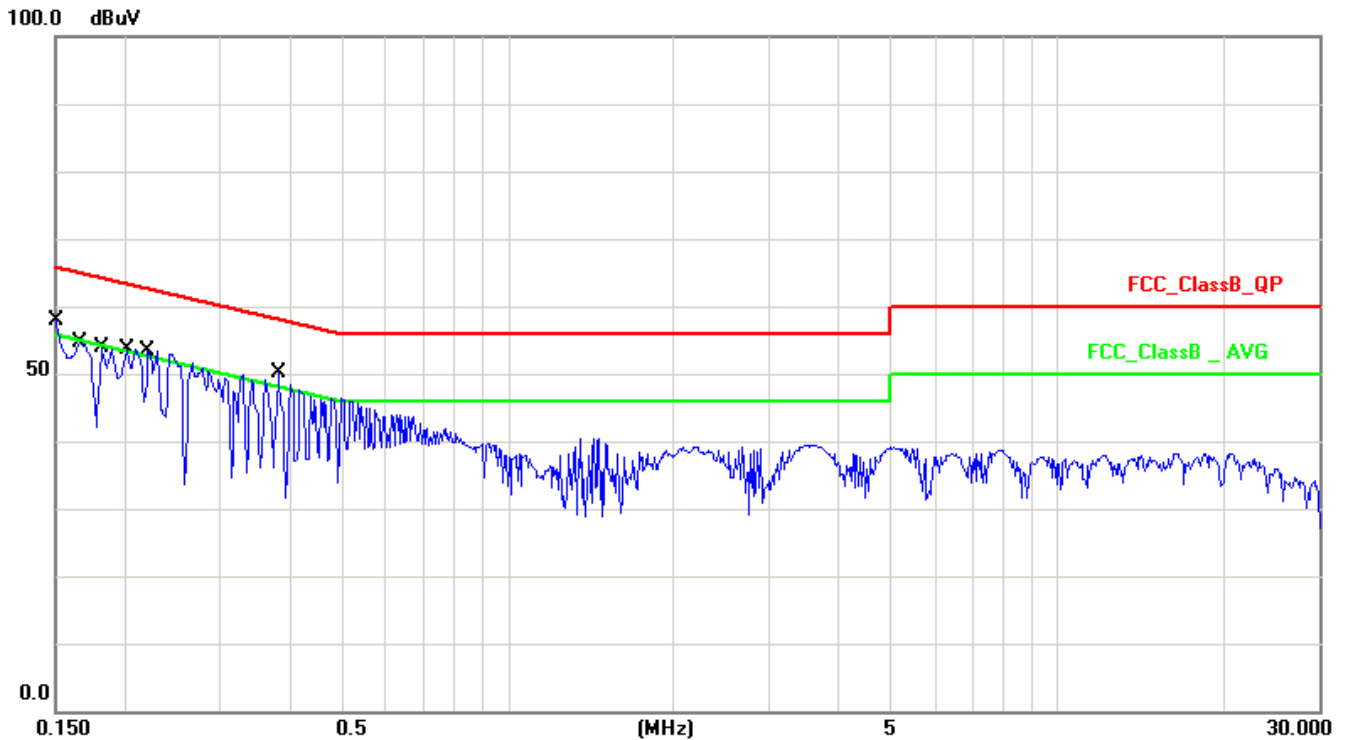

No.	Frequency (MHz)	Factor (dB)	Reading (dBuV)	Level (dBuV)	Limit (dBuV)	Margin (dB)	Detector
1	0.1500	10.15	36.64	46.79	65.99	-19.20	QP
2	0.1500	10.15	7.22	17.37	55.99	-38.62	AVG
3	0.1660	10.15	35.59	45.74	65.15	-19.41	QP
4	0.1660	10.15	6.31	16.46	55.15	-38.69	AVG
5	0.1819	10.13	34.80	44.93	64.39	-19.46	QP
6	0.1819	10.13	6.26	16.39	54.39	-38.00	AVG
7	0.2020	10.13	34.62	44.75	63.52	-18.77	QP
8	0.2020	10.13	6.75	16.88	53.52	-36.64	AVG
9	0.2220	10.13	34.27	44.40	62.74	-18.34	QP
10	0.2220	10.13	6.83	16.96	52.74	-35.78	AVG
11	0.3820	10.15	29.12	39.27	58.23	-18.96	QP
12	0.3820	10.15	7.35	17.50	48.23	-30.73	AVG

Note: Measurement Level = Reading Level + Correct Factor



Test Mode :	Mode 1: Normal Operation with WIFI on		
AC Power :	AC 120V/60Hz	Phase :	NEUTRAL
Temperature :	26°C	Humidity :	60%
Pressure(mbar) :	1002	Date:	2018/06/09

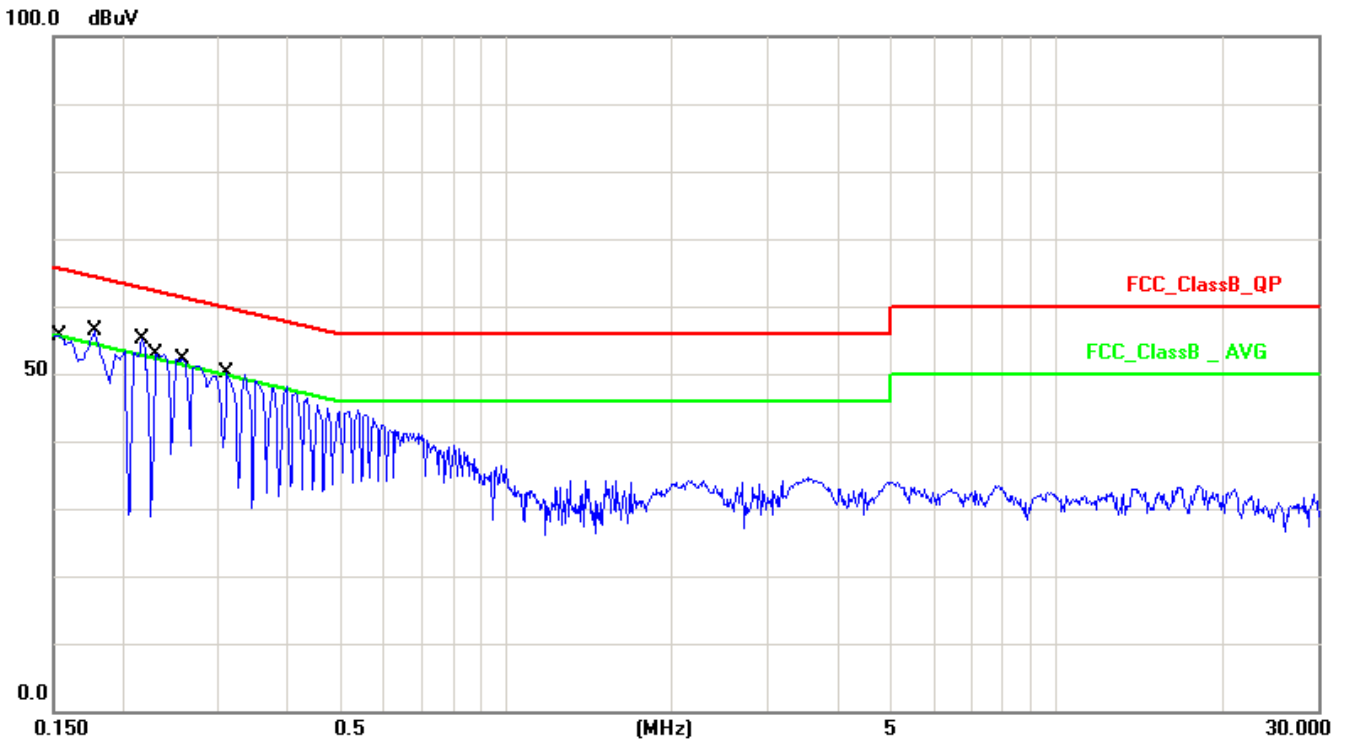

No.	Frequency (MHz)	Factor (dB)	Reading (dBuV)	Level (dBuV)	Limit (dBuV)	Margin (dB)	Detector
1	0.1539	10.15	36.09	46.24	65.78	-19.54	QP
2	0.1539	10.15	6.34	16.49	55.78	-39.29	AVG
3	0.1780	10.14	34.78	44.92	64.57	-19.65	QP
4	0.1780	10.14	5.27	15.41	54.57	-39.16	AVG
5	0.2180	10.14	34.17	44.31	62.89	-18.58	QP
6	0.2180	10.14	5.09	15.23	52.89	-37.66	AVG
7	0.2304	10.14	33.94	44.08	62.43	-18.35	QP
8	0.2304	10.14	5.35	15.49	52.43	-36.94	AVG
9	0.2580	10.14	32.78	42.92	61.49	-18.57	QP
10	0.2580	10.14	5.14	15.28	51.49	-36.21	AVG
11	0.3100	10.14	29.50	39.64	59.97	-20.33	QP
12	0.3100	10.14	3.73	13.87	49.97	-36.10	AVG

Note: Measurement Level = Reading Level + Correct Factor



5. Radiated Emission Measurement

5.1 Test Limit

In any 100kHz bandwidth outside the frequency band in which the spread spectrum or digitally modulated intentional radiator is operating, the radio frequency power that is produced by the intentional radiator shall be at least 20dB below that in the 100kHz bandwidth within the band that contains the highest level of the desired power, based on either an RF conducted or a radiated measurement. If the transmitter measurement is based on the maximum conducted output power, the attenuation required under this paragraph shall be 30dB instead of 20dB. In addition, radiated emissions which fall in section 15.205(a) the restricted bands must also comply with the radiated emission limit specified in section 15.209(a).

FCC Part 15 Subpart C Paragraph 15.209		
FREQUENCIES (MHz)	FIELD STRENGTH (micro volts/meter)	MEASUREMENT DISTANCE (meters)
0.009~0.490	2400/F(kHz)	300
0.490~1.705	24000/F(kHz)	30
1.705~30.0	30	30
30~88	100	3
88~216	150	3
216~960	200	3
Above 960	500	3

Note 1: The lower limit shall apply at the transition frequency.

Note 2: Distance refers to the distance in meters between the measuring instrument Antenna and the closed point of any part of the device or system.

Note 3: E field strength (dBuV/m) = 20 log E field strength (uV/m)

Note 4: **Except as provided in paragraph (g), fundamental emissions from intentional radiators operating under this section shall not be located in the frequency bands 54-72 MHz, 76-88 MHz, 174-216 MHz or 470-806 MHz. However, operation within these frequency bands is permitted under other sections of this part, e.g., §§15.231 and 15.241.

5.2 Test Standard

KDB 558074 D01v04 - Section 12.2.3 (quasi-peak measurements)

KDB 558074 D01v04 - Section 12.2.4 (peak power measurements)

KDB 558074 D01v04- Section 12.2.5 (average power measurements)



5.3 Test Procedures

Quasi-Peak Field Strength Measurements:

The specifications for measurements using the CISPR quasi-peak detector can be found in Publication 16 of the International Special Committee on Radio Frequency Interference (CISPR) of the International Electrotechnical Commission.

As an alternative to CISPR quasi-peak measurement, compliance can be demonstrated to the applicable emission limits using a peak detector.

Peak Field Strength Measurements:

Analyzer center frequency was set to the frequency of the radiated spurious emission of interest

1. RBW=As specified in Table 1
2. VBW=3xRBW
3. Detector=Peak
4. Trace mode=Max hold
5. Sweep time=Auto couple
6. Allow the trace to stabilize

Table 1-RBW as a function of frequency

Frequency	RBW
9 ~ 150kHz	200 ~ 300Hz
0.15 ~ 30MHz	9 ~ 10kHz
30 ~ 1000MHz	100 ~ 120kHz
> 1000MHz	1MHz

AVE Field Strength Measurements:

Analyzer center frequency was set to the frequency of the radiated spurious emission of interest

1. RBW= 1MHz
2. VBW \geq 1/T
3. Detector=Peak
4. Trace mode=Max hold
5. Sweep time=Auto couple
6. Allow max hold to run for at least 50 times(1/duty cycle) trace

Do as an alternative, the instrument may be set to linear detector mode. Ensure that video filtering is applied in linear voltage domain (rather than in a log or dB domain). Some instruments require linear display mode in order to accomplish this. Others have a setting for Average-VBW Type, which can be set to "Voltage" regardless of the display mode



5.4 Test Setup Layout

9kHz~30MHz Test Setup

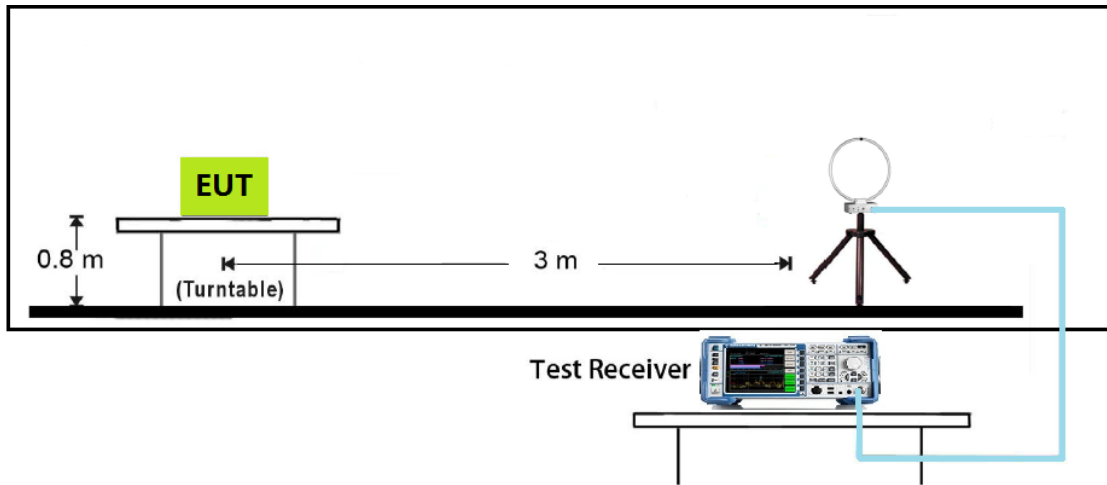

30MHz~1GHz Test Setup

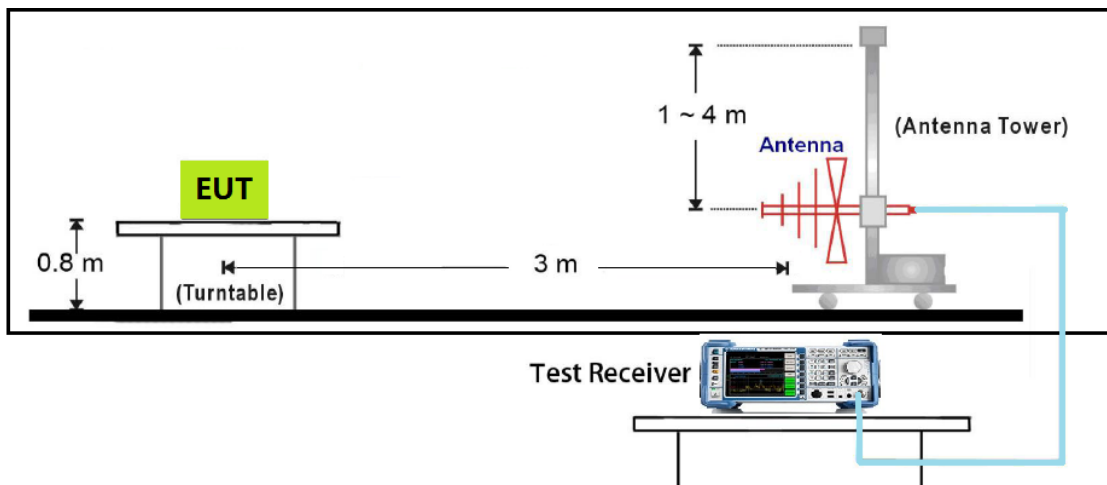



1GHz~18GHz Test Setup

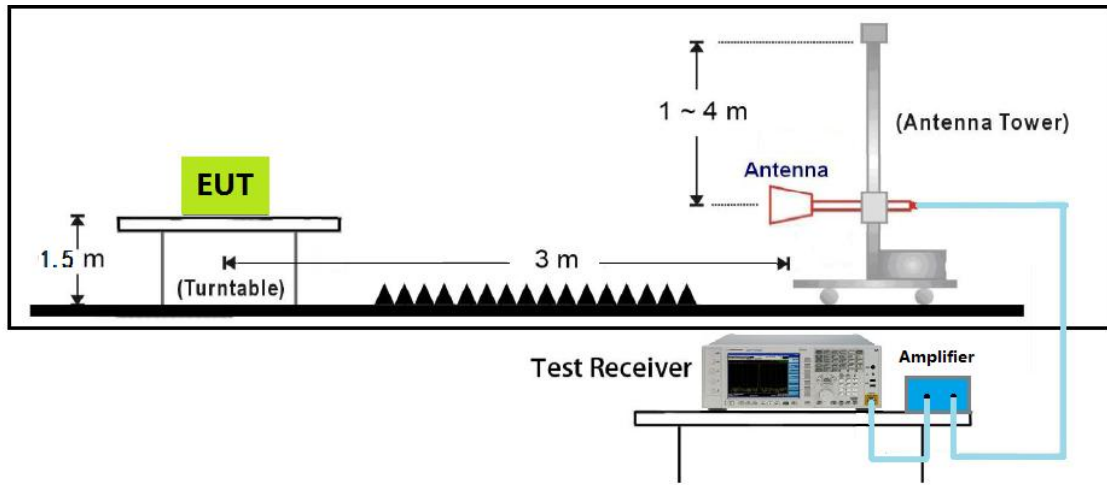

18GHz~40GHz Test Setup

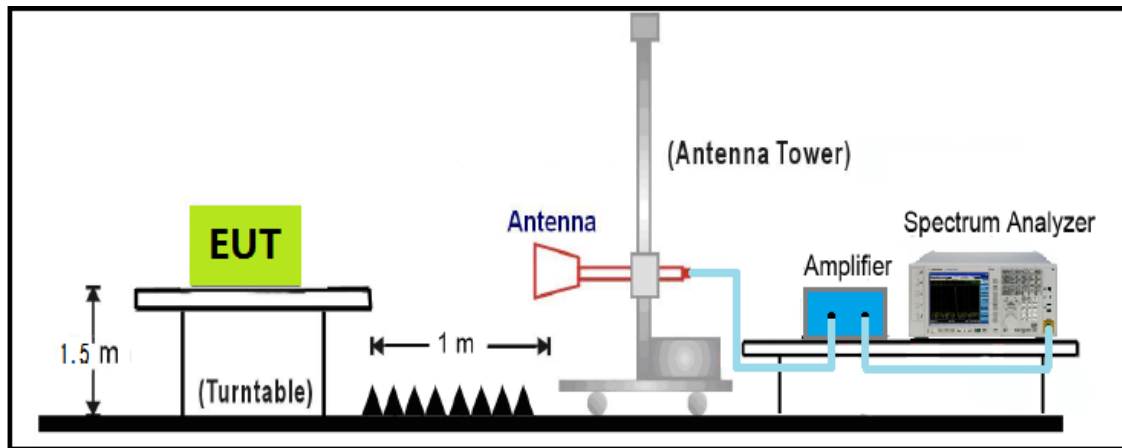



5.5 Test Result

Limit: FCC_Part15.209_RE(3m)	Margin: 0
Probe: CBL6112D (30-1000MHz)	Polarity: Horizontal
EUT: Remote Control Socket	Power: AC 120V/60Hz
Note: Mode1: Transmit at channel 2437MHz by 802.11b	

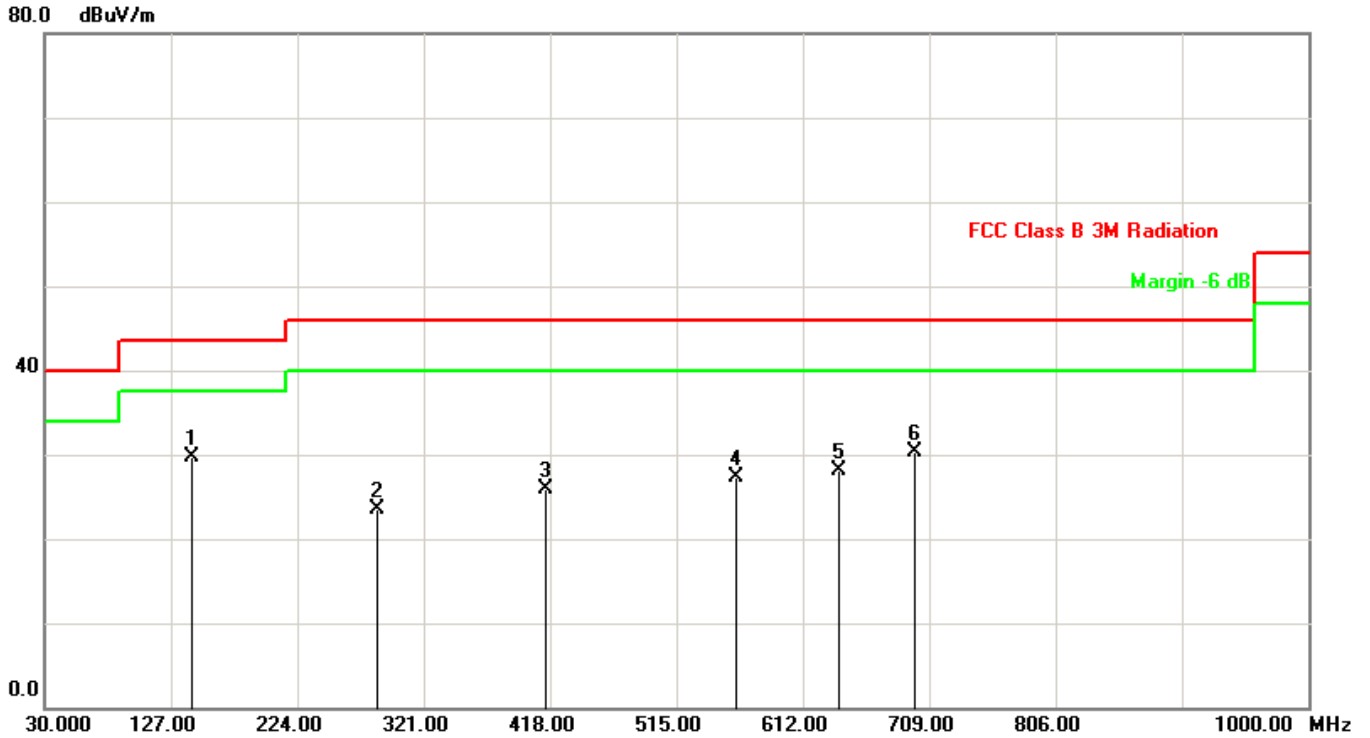

No.	Frequency (MHz)	Factor (dB/m)	Reading (dBuV)	Level (dBuV/m)	Limit (dBuV/m)	Margin (dB)	Det.
1	143.4900	-12.77	42.43	29.66	43.50	-13.84	QP
2	285.1099	-8.80	32.35	23.55	46.00	-22.45	QP
3	414.1200	-4.00	29.82	25.82	46.00	-20.18	QP
4	560.5900	-3.28	30.60	27.32	46.00	-18.68	QP
5	640.1299	-1.98	30.02	28.04	46.00	-17.96	QP
6	697.3600	0.88	29.37	30.25	46.00	-15.75	QP

Note: Measure Level (dBuV/m) = Reading Level (dBuV) + Factor(dB).

Factor (dB)=Cable Loss(dB) + Antenna Factor (dB/m) - Pre_Amplifier Gain(dB)



Limit: FCC_Part15.209_RE(3m)	Margin: 0
Probe: CBL6112D (30-1000MHz)	Polarity: Vertical
EUT: Remote Control Socket	Power: AC 120V/60Hz
Note: Mode1: Transmit at channel 2437MHz by 802.11b	

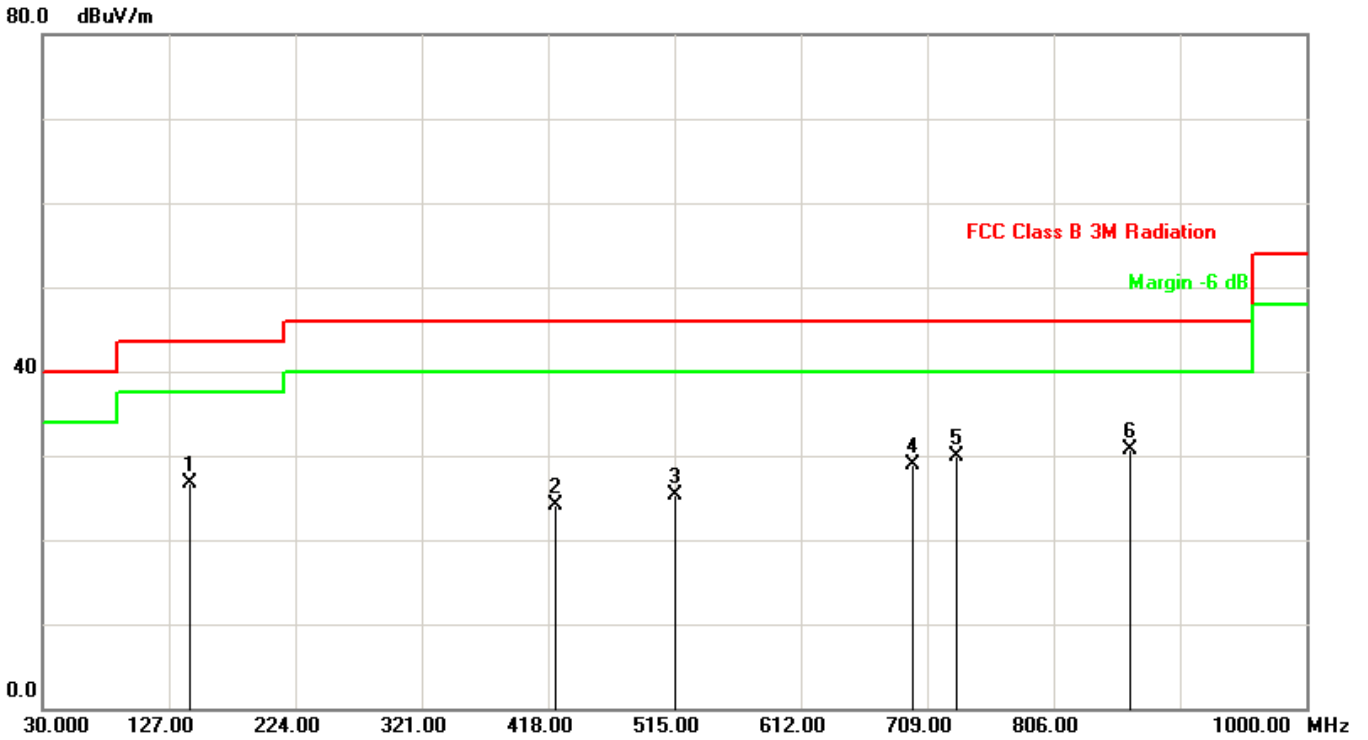

No.	Frequency (MHz)	Factor (dB/m)	Reading (dBuV)	Level (dBuV/m)	Limit (dBuV/m)	Margin (dB)	Det.
1	143.4900	-12.77	39.48	26.71	43.50	-16.79	QP
2	423.8199	-3.69	27.73	24.04	46.00	-21.96	QP
3	515.9699	-4.52	29.86	25.34	46.00	-20.66	QP
4	697.3600	0.88	28.08	28.96	46.00	-17.04	QP
5	732.2798	1.54	28.46	30.00	46.00	-16.00	QP
6	865.1698	1.97	28.83	30.80	46.00	-15.20	QP

Note: Measure Level (dBuV/m) = Reading Level (dBuV) + Factor(dB).

Factor (dB)=Cable Loss(dB) + Antenna Factor (dB/m) - Pre_Amplifier Gain(dB)

**Radiated Emission above 1GHz:**

Mode1: Transmit by 802.11b

CH	Antenna	Frequency (MHz)	Reading Level (dBuV/m)	Factor (dB)	Measure Level (dBuV/m)	Limit (dBuV/m)	Margin (dB)	Detector
1	H	4824.00	45.71	3.32	49.03	54(note3)	-4.97	PK
	H	7236.00	38.30	8.22	46.52	54(note3)	-7.48	PK
	V	4824.00	45.81	3.32	49.13	54(note3)	-4.87	PK
	V	7236.00	35.80	8.22	44.02	54(note3)	-9.98	PK
6	H	4874.00	47.54	3.42	50.96	54(note3)	-3.04	PK
	H	7311.00	38.51	8.27	46.78	54(note3)	-7.22	PK
	V	4874.00	47.25	3.42	50.67	54(note3)	-3.33	PK
	V	7311.00	36.14	8.27	44.41	54(note3)	-9.59	PK
11	H	4924.00	46.08	3.52	49.60	54(note3)	-4.40	PK
	H	7386.00	38.12	8.32	46.44	54(note3)	-7.56	PK
	V	4924.00	46.06	3.52	49.58	54(note3)	-4.42	PK
	V	7386.00	35.61	8.32	43.93	54(note3)	-10.07	PK

Note: 1. Measure Level = Reading Level + Factor.

2. The test trace is same as the ambient noise (the test frequency range: 9kHz~30MHz, 18GHz~25GHz), therefore no data appear in the report.

3. This limit applies for using average detector, if the test result on peak is lower than average limit, then average measurement needn't be performed.



Mode2: Transmit by 802.11g

CH	Antenna	Frequency (MHz)	Reading Level (dBuV/m)	Factor (dB)	Measure Level (dBuV/m)	Limit (dBuV/m)	Margin (dB)	Detector
1	H	4824.00	48.10	3.32	51.42	54(note3)	-2.58	PK
	H	7236.00	38.02	8.22	46.24	54(note3)	-7.76	PK
	V	4824.00	47.50	3.32	50.82	54(note3)	-3.18	PK
	V	7236.00	35.88	8.22	44.10	54(note3)	-9.90	PK
6	H	4874.00	48.19	3.42	51.61	54(note3)	-2.39	PK
	H	7311.00	38.23	8.27	46.50	54(note3)	-7.50	PK
	V	4874.00	47.33	3.42	50.75	54(note3)	-3.25	PK
	V	7311.00	36.02	8.27	44.29	54(note3)	-9.71	PK
11	H	4924.00	47.99	3.52	51.51	54(note3)	-2.49	PK
	H	7386.00	38.32	8.32	46.64	54(note3)	-7.36	PK
	V	4924.00	46.85	3.52	50.37	54(note3)	-3.63	PK
	V	7386.00	35.73	8.32	44.05	54(note3)	-9.95	PK

Note: 1. Measure Level = Reading Level + Factor.

2. The test trace is same as the ambient noise (the test frequency range: 9kHz~30MHz, 18GHz~25GHz), therefore no data appear in the report.

3. This limit applies for using average detector, if the test result on peak is lower than average limit, then average measurement needn't be performed.



Mode3: Transmit by 802.11n(20MHz)

CH	Antenna	Frequency (MHz)	Reading Level (dBuV/m)	Factor (dB)	Measure Level (dBuV/m)	Limit (dBuV/m)	Margin (dB)	Detector
1	H	4824.00	47.78	3.32	51.10	54(note3)	-2.90	PK
	H	7236.00	37.96	8.22	46.18	54(note3)	-7.82	PK
	V	4824.00	47.75	3.32	51.07	54(note3)	-2.93	PK
	V	7236.00	35.99	8.22	44.21	54(note3)	-9.79	PK
6	H	4874.00	47.86	3.42	51.28	54(note3)	-2.72	PK
	H	7311.00	38.34	8.27	46.61	54(note3)	-7.39	PK
	V	4874.00	47.17	3.42	50.59	54(note3)	-3.41	PK
	V	7311.00	35.90	8.27	44.17	54(note3)	-9.83	PK
11	H	4924.00	48.40	3.52	51.92	54(note3)	-2.08	PK
	H	7386.00	38.31	8.32	46.63	54(note3)	-7.37	PK
	V	4924.00	47.60	3.52	51.12	54(note3)	-2.88	PK
	V	7386.00	35.75	8.32	44.07	54(note3)	-9.93	PK

Note: 1. Measure Level = Reading Level + Factor.

2. The test trace is same as the ambient noise (the test frequency range: 9kHz~30MHz, 18GHz~25GHz), therefore no data appear in the report.

3. This limit applies for using average detector, if the test result on peak is lower than average limit, then average measurement needn't be performed.



The worst case of Radiated Emission 1~18GHz:

Site: AC102	Time: 2018/06/09
Limit: FCC_Part15.209_RE(3m)	Margin: 0
Probe: N/A	Polarity: Horizontal
EUT: Remote Control Socket	Power: AC 120V/60Hz
Note: Mode: Transmit 802.11b at 2437MHz	

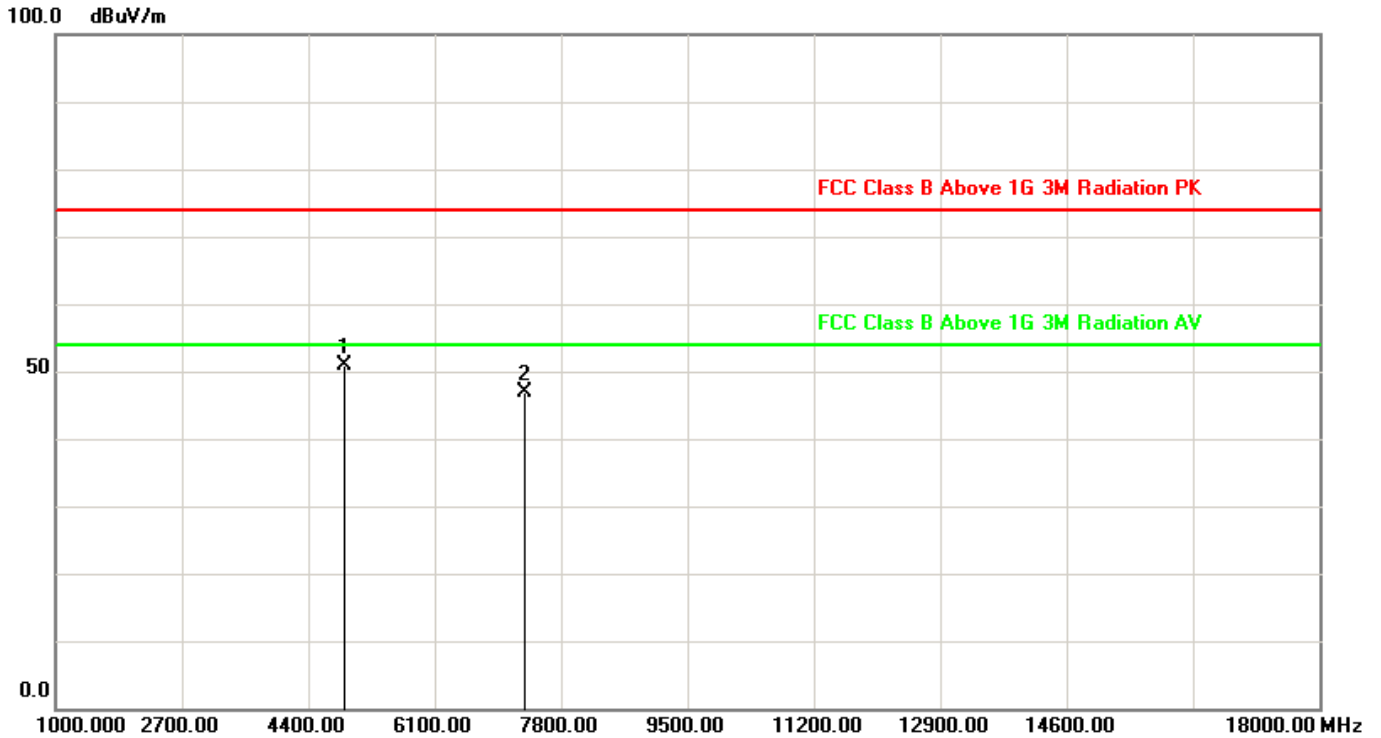

No.	Frequency (MHz)	Reading (dBuV)	Factor (dB/m)	Level (dBuV/m)	Limit (dBuV/m)	Margin (dB)	Det.
1	4874.00	47.54	3.42	50.96	54(note3)	-3.04	peak
2	7311.00	38.51	8.27	46.78	54(note3)	-7.22	peak

Note:

1. All Readings below 1GHz are Quasi-Peak, above are performed with peak and/or AVG measurements as necessary.
2. Measurement Level = Reading Level + Correct Factor
3. The test trace is same as the ambient noise (the test frequency range: 9kHz~30MHz, 18GHz~40GHz), therefore no data appear in the report.



Site: AC102	Time: 2018/06/09
Limit: FCC_Part15.209_RE(3m)	Margin: 0
Probe: N/A	Polarity: Vertical
EUT: Remote Control Socket	Power: AC 120V/60Hz
Note: Mode: Transmit 802.11b at 2437MHz	

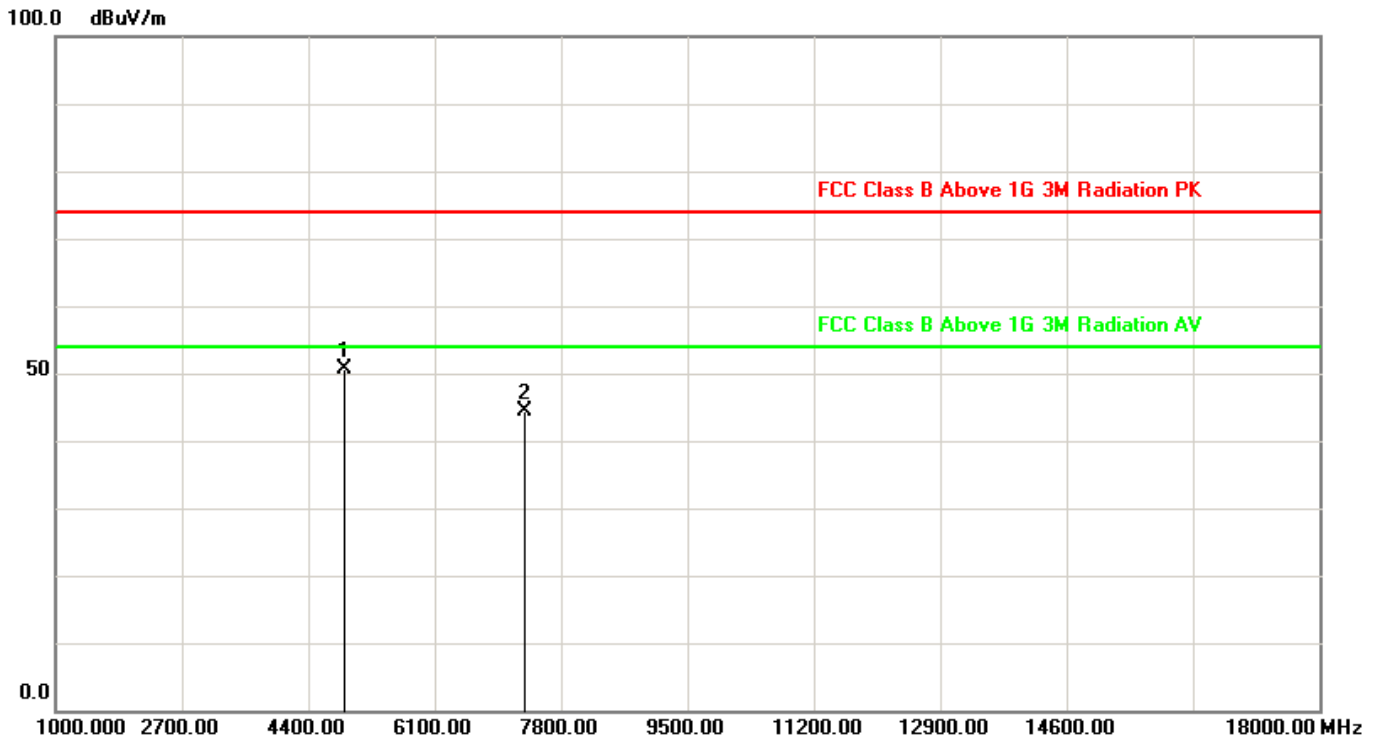

No.	Frequency (MHz)	Reading (dBuV)	Factor (dB/m)	Level (dBuV/m)	Limit (dBuV/m)	Margin (dB)	Det.
1	4874.00	47.25	3.42	50.67	54(note3)	-3.33	peak
2	7311.00	36.14	8.27	44.41	54(note3)	-9.59	peak

Note:

1. All Readings below 1GHz are Quasi-Peak, above are performed with peak and/or AVG measurements as necessary.
2. Measurement Level = Reading Level + Correct Factor
3. The test trace is same as the ambient noise (the test frequency range: 9kHz~30MHz, 18GHz~40GHz), therefore no data appear in the report.



6. 6dB Bandwidth Measurement

6.1 Test Limit

According to FCC part15.247 - Section (a)(2), the minimum 6dB bandwidth shall be at least 500 kHz.

6.2 Test Standard

KDB 558074 D01v04– Section 8.2 Option 2

6.3 Test Procedures

1. Set RBW=100KHz
2. VBW \geq 3 \times RBW
3. Detector=Peak
4. Trace mode=Max hold
5. Sweep time=Auto couple
6. Allow the trace to stabilize
7. The Spectrum's automatic bandwidth measurement capability was used to perform the 6dB bandwidth measurement. The "X" dB bandwidth parameter was set to X = 6. The bandwidth measurement was not influenced by any intermediate power nulls in the fundamental emission.

6.4 Test Setup Layout

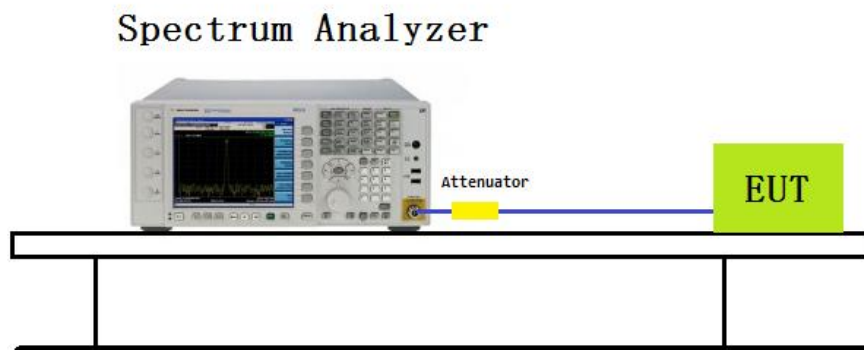



6.5 Test Result

Test Item	Occupied Bandwidth
Test Mode	Mode 1: Transmit by 802.11b

Channel No.	Frequency(MHz)	6dB Bandwidth(MHz)	99% Bandwidth(MHz)
1	2412	10.12	15.038
6	2437	10.12	14.862
11	2462	10.12	14.940





Test Item	Occupied Bandwidth
Test Mode	Mode 2: Transmit by 802.11g

Channel No.	Frequency(MHz)	6dB Bandwidth(MHz)	99% Bandwidth(MHz)
1	2412	16.38	16.843
6	2437	16.39	16.678
11	2462	16.37	16.693





Test Item	Occupied Bandwidth
Test Mode	Mode 3: Transmit by 802.11n(20MHz)

Channel No.	Frequency(MHz)	6dB Bandwidth(MHz)	99% Bandwidth(MHz)
1	2412	17.67	17.821
6	2437	17.64	17.825
11	2462	17.64	17.828

Channel 1 (2412MHz)

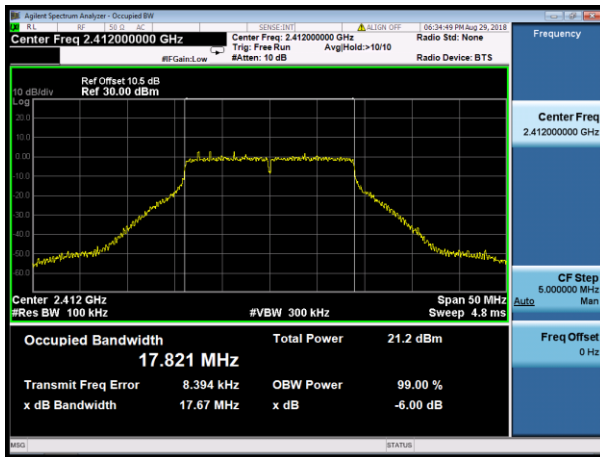

Channel 6 (2437MHz)

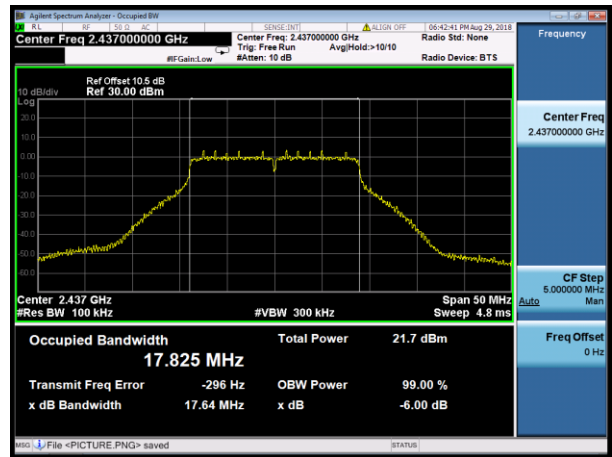

Channel 11 (2462MHz)

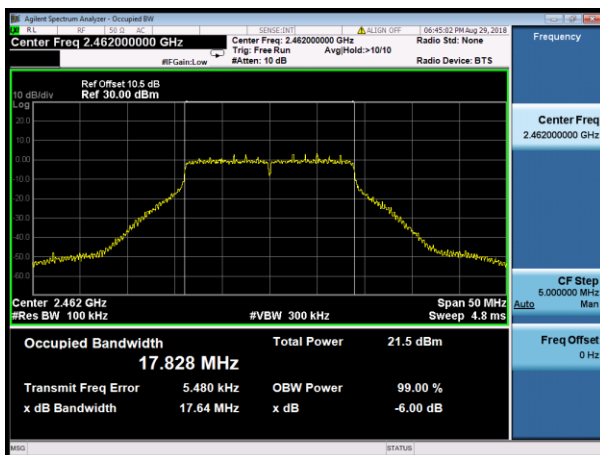



7. Output Power Measurement

7.1 Test Limit

According to FCC part15.247 (b) (3), for systems using digital modulation in the 902-928 MHz, 2400-2483.5 MHz, and 5725-5850MHz bands: 1 Watt. As an alternative to a peak power measurement, compliance with the one Watt limit can be based on a measurement of the maximum conducted output power. Maximum Conducted Output Power is defined as the total transmit power delivered to all antennas and antenna elements averaged across all symbols in the signaling alphabet when the transmitter is operating at its maximum power control level. Power must be summed across all antennas and antenna elements. The average must not include any time intervals during which the transmitter is off or is transmitting at a reduced power level. If multiple modes of operation are possible (e.g., alternative modulation methods), the maximum conducted output power is the highest total transmit power occurring in any mode.

Per RSS247 Issue 2 Section 5.4(d), for DTSs employing digital modulation techniques operating in the bands 902-928 MHz and 2400-2483.5 MHz, the maximum peak conducted output power shall not exceed 1W.

7.2 Test Standard

KDB 558074 D01v04 - Section 9.1.2 PKPM1 Peak Power Method (for signals with BW \leq 50MHz)

7.3 Test Procedures

Out power measurements were performed only when the EUT was transmitting at its maximum power control level using a broadband power meter with a pulse sensor. The pulse sensor employs a VBW = 50MHz so this method was only used for signals whose DTS bandwidth was less than or equal to 50MHz.

7.4 Test Setup Layout

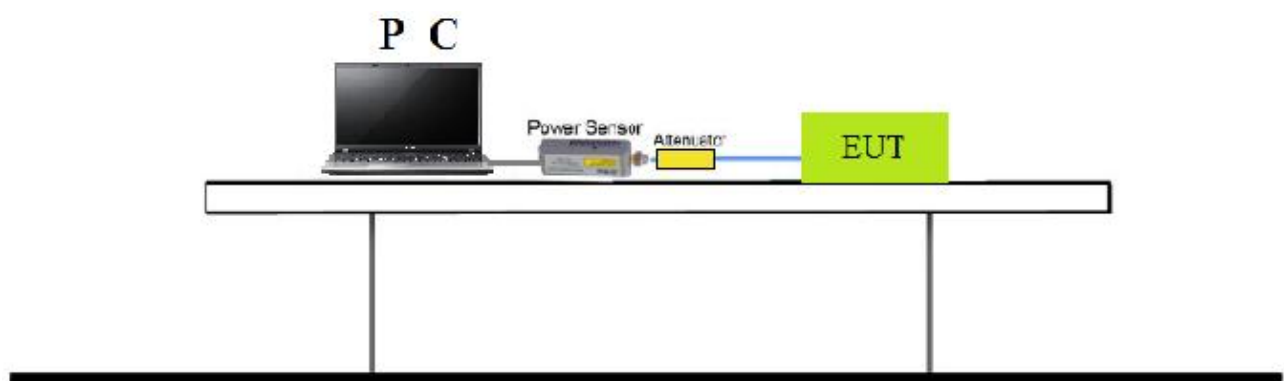



7.5 Test Result

For Peak Power :

Test Mode	Channel No.	Frequency (MHz)	Peak Output Power (dBm)	Limit (dBm)	Result
802.11b	1	2412	21.93	30	Pass
	6	2437	21.43	30	Pass
	11	2462	21.25	30	Pass
802.11g	1	2412	21.76	30	Pass
	6	2437	22.08	30	Pass
	11	2462	22.06	30	Pass
802.11n(20MHz)	1	2412	20.86	30	Pass
	6	2437	21.18	30	Pass
	11	2462	21.05	30	Pass



8. Power Spectral Density Measurement

8.1 Test Limit

According to FCC part15.247 - Section (e), for digitally modulated systems, the power spectral density conducted from the intentional radiator to the antenna shall not be greater than 8 dBm in any 3 kHz band during any time interval of continuous transmission. This power spectral density shall be determined in accordance with the provisions of paragraph (b) of this section. The same method of determining the conducted output power shall be used to determine the power spectral density.

8.2 Test Standard

KDB 558074 D01v04- Section 10.2 Method PKPSD

8.3 Test Procedures

1. Set RBW=3kHz
2. Set RBW=10kHz
3. Span = 1.5 times the DTS channel bandwidth
4. Detector=Peak
5. Trace mode=Max hold
6. Sweep time=Auto couple
7. Allow the trace to stabilize
8. Analyzer was set to the center frequency of the DTS channel under investigation.

8.4 Test Setup Layout

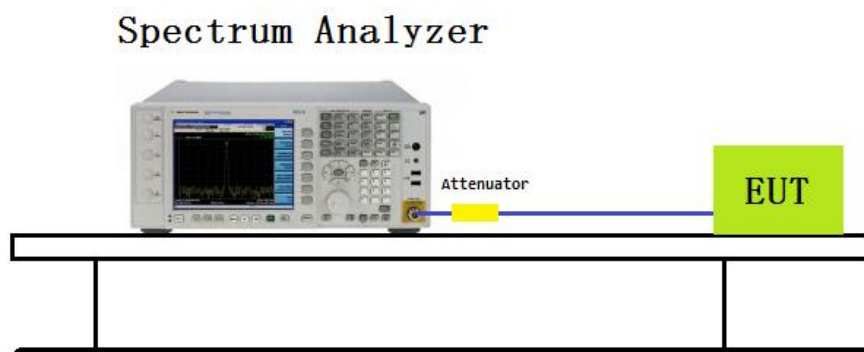



8.5 Test Result

Test Mode	Channel No.	Frequency(MHz)	Power Spectral Density (dBm/3kHz)	Limit (dBm/3kHz)	Result
802.11b	1	2412	-6.383	8	Pass
	6	2437	-5.785	8	Pass
	11	2462	-6.294	8	Pass
802.11g	1	2412	-9.752	8	Pass
	6	2437	-9.912	8	Pass
	11	2462	-10.007	8	Pass
802.11n(20M Hz)	1	2412	-11.616	8	Pass
	6	2437	-11.000	8	Pass
	11	2462	-11.707	8	Pass



Test Item	Power Spectral Density
Test Mode	Mode 1: Transmit by 802.11b

Channel 1 (2412MHz)

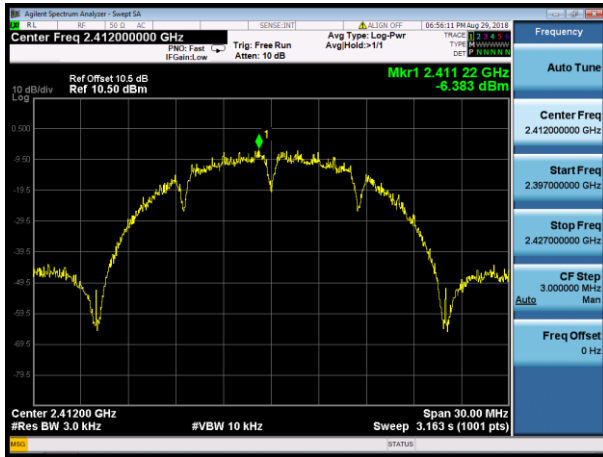

Channel 6 (2437MHz)

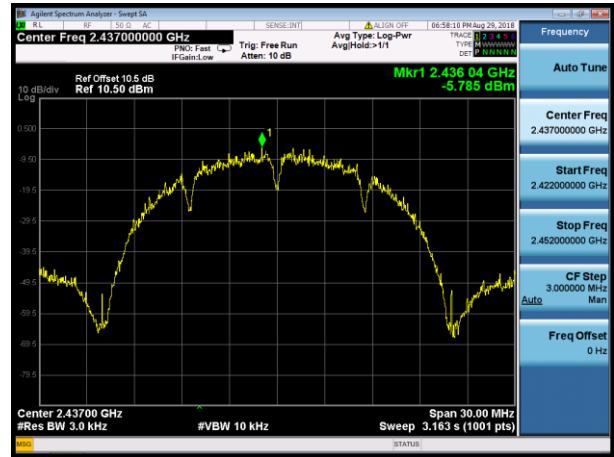

Channel 11 (2462MHz)

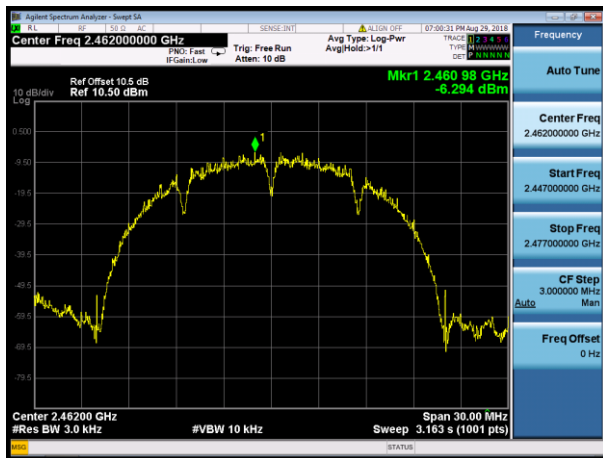



Test Item	Power Spectral Density
Test Mode	Mode 2: Transmit by 802.11g

Channel 1 (2412MHz)

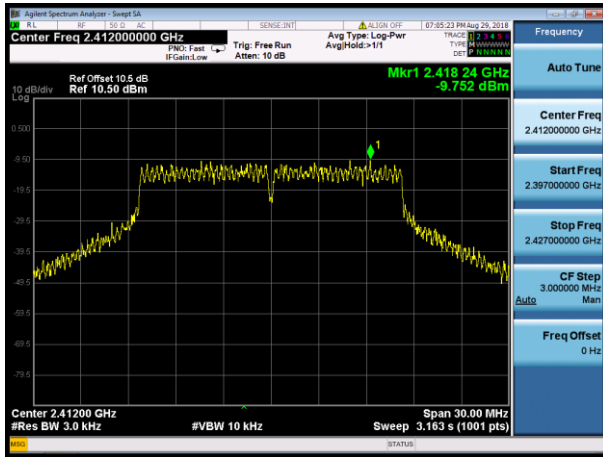

Channel 6 (2437MHz)

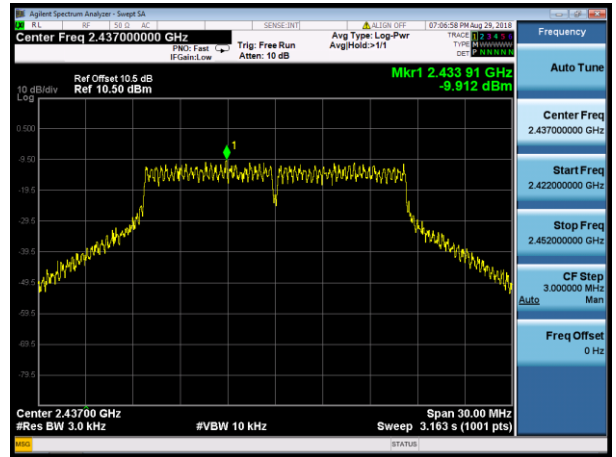

Channel 11 (2462MHz)

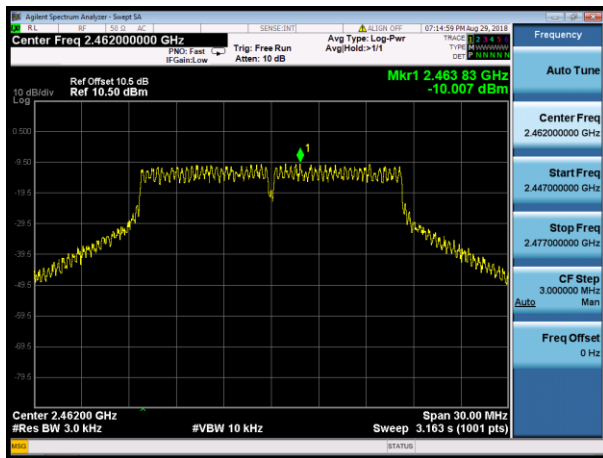



Test Item	Power Spectral Density
Test Mode	Mode 3: Transmit by 802.11n(20MHz)

Channel 1 (2412MHz)

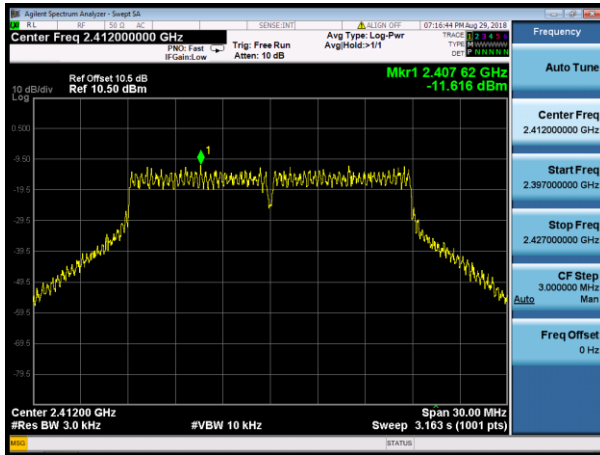

Channel 6 (2437MHz)

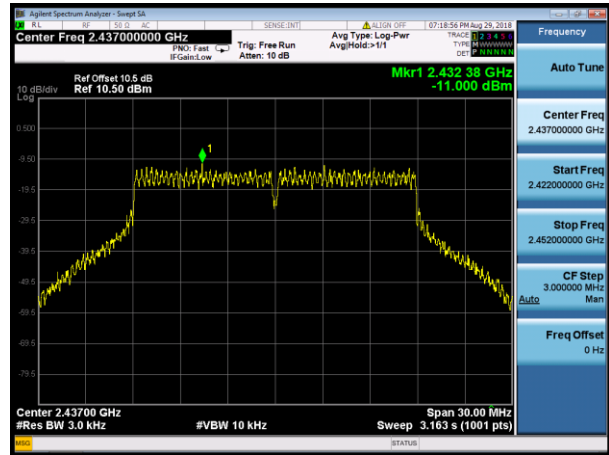

Channel 11 (2462MHz)

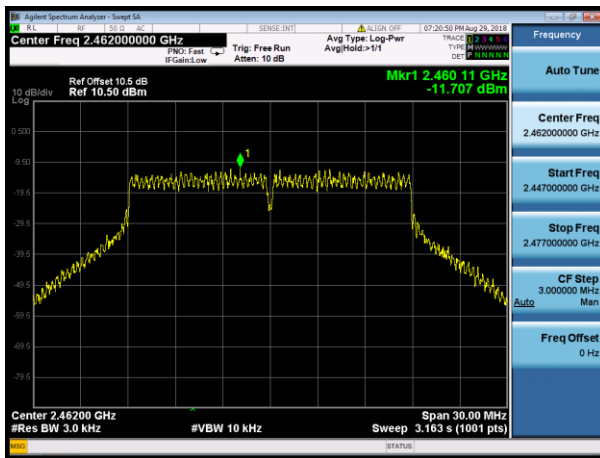



9. Conducted Band Edge and Out-of-Band Emissions Measurement

9.1 Test Limit

According to FCC part 15.247(d) , in any 100 kHz bandwidth outside the frequency band in which the spread spectrum or digitally modulated intentional radiator is operating, the radio frequency power that is produced by the intentional radiator shall be at least 20 dB below that in the 100 kHz bandwidth within the band that contains the highest level of the desired power, based on either an RF conducted or a radiated measurement, provided the transmitter demonstrates compliance with the peak conducted or a radiated measurement, provided the transmitter demonstrates compliance with the peak conducted power limits. If the transmitter complies with the conducted power limits based on the use of RMS averaging over a time interval, the attenuation required under this paragraph shall be 30 dB instead of 20 dB. Attenuation below the general limits specified in Section 15.209(a) of FCC part 15 is not required.

9.2 Test Standard

KDB 558074 D01v04 - Section 11.2 & Section 11.3



9.3 Test Procedures

Reference level measurement:

1. Set the RBW = 100 kHz
2. Set the VBW $\geq 3 \times$ RBW
3. Set the span to ≥ 1.5 times the DTS bandwidth
4. Detector = peak
5. Trace mode = max hold
6. Sweep time = auto couple
7. Allow trace to fully stabilize
8. Set instrument center frequency to DTS channel center frequency

Emission level measurement:

1. RBW = 100kHz
2. VBW = 300kHz
3. Detector = Peak
4. Trace mode = max hold
5. Sweep time = auto couple
6. The trace was allowed to stabilize
7. Set the center frequency and span to encompass frequency range to be measured

9.4 Test Setup Layout

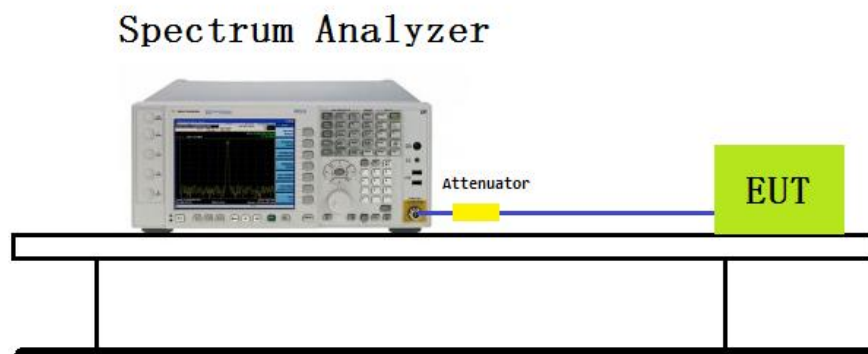



9.5 Test Result

Test Mode	Channel No.	Frequency (MHz)	Limit	Result
802.11b	1	2412	20dBc	Pass
	6	2437	20dBc	Pass
	11	2462	20dBc	Pass
802.11g	1	2412	20dBc	Pass
	6	2437	20dBc	Pass
	11	2462	20dBc	Pass
802.11n(20MHz)	1	2412	20dBc	Pass
	6	2437	20dBc	Pass
	11	2462	20dBc	Pass



Test Item	:	Conducted Band Edge and Out-of-Band Emissions
Test Mode	:	Mode 1: Transmit by 802.11b

Mode 1: Transmit by 802.11b (2412MHz)

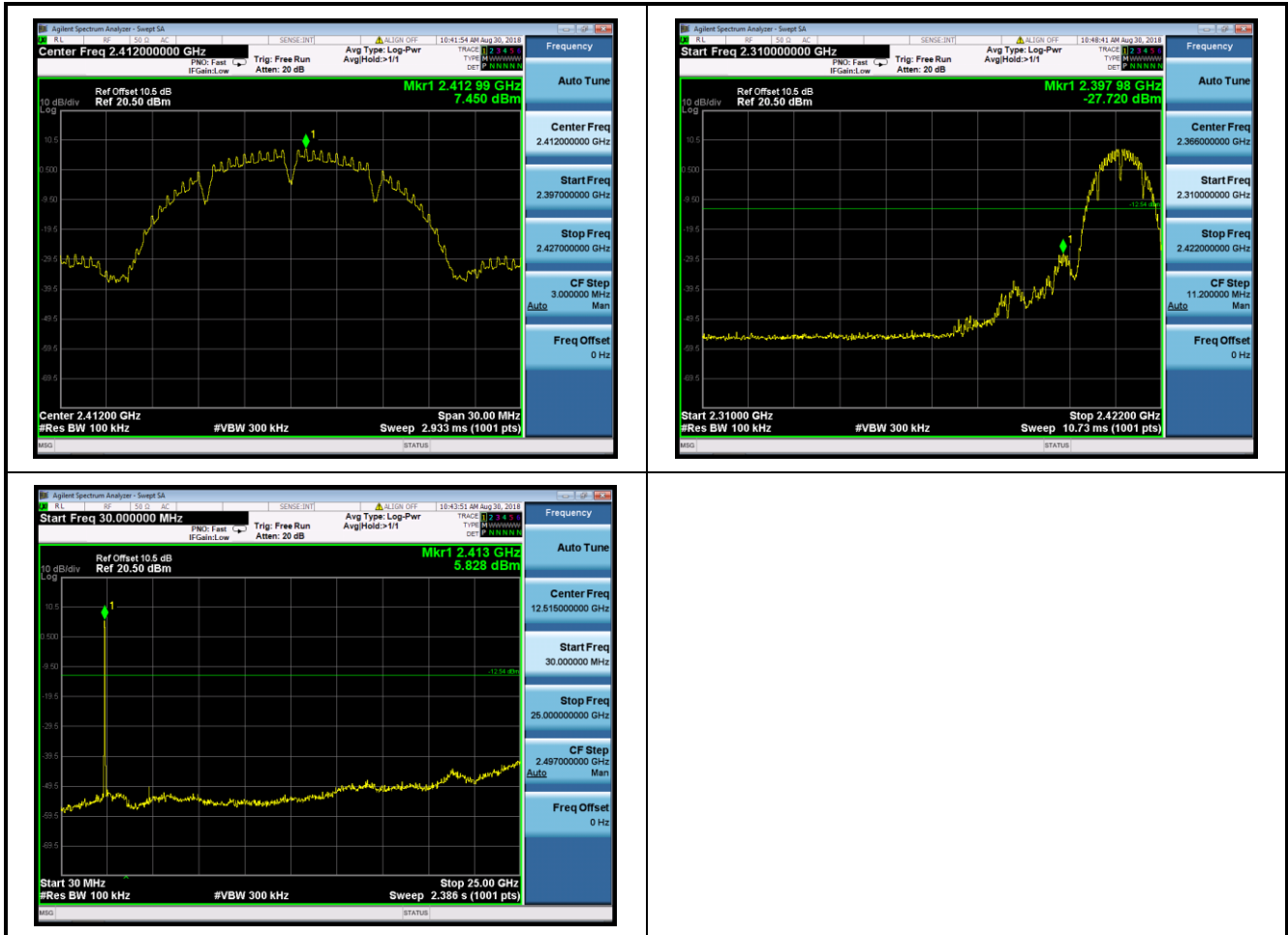



Mode 1: Transmit by 802.11b (2437MHz)

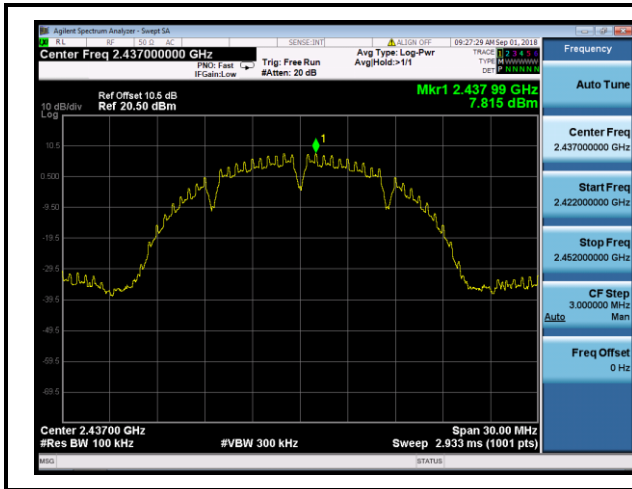

Mode 1: Transmit by 802.11b (2462MHz)

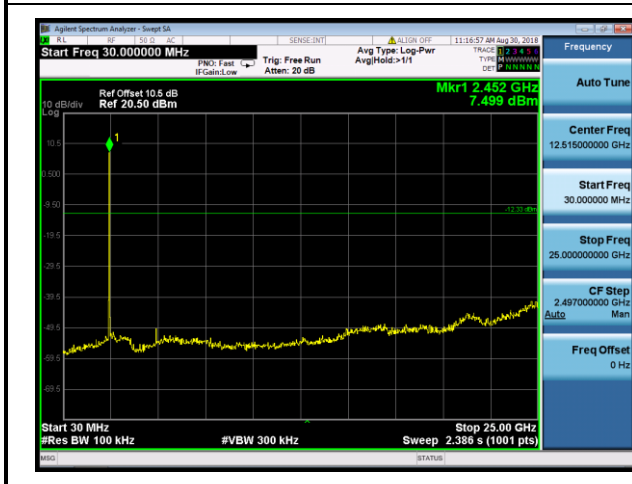
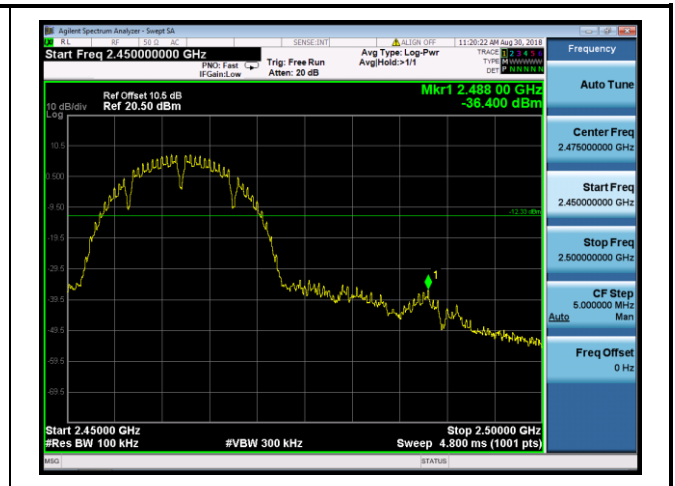
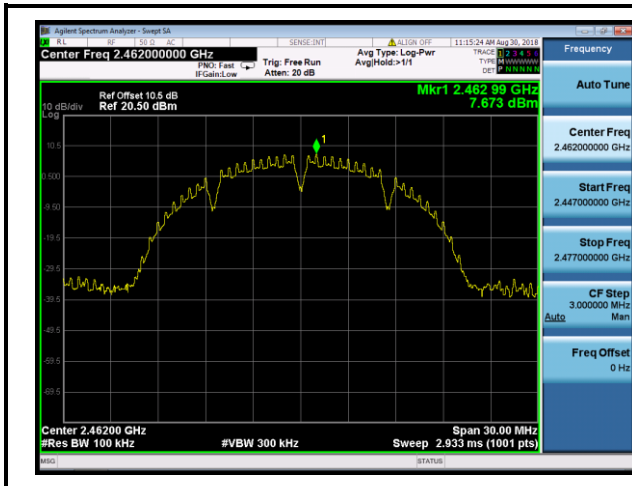



Test Item	:	Band-edge Compliance & Conducted Spurious Emissions
Test Mode	:	Mode 2: Transmit by 802.11g

Mode 2: Transmit by 802.11g (2412MHz)

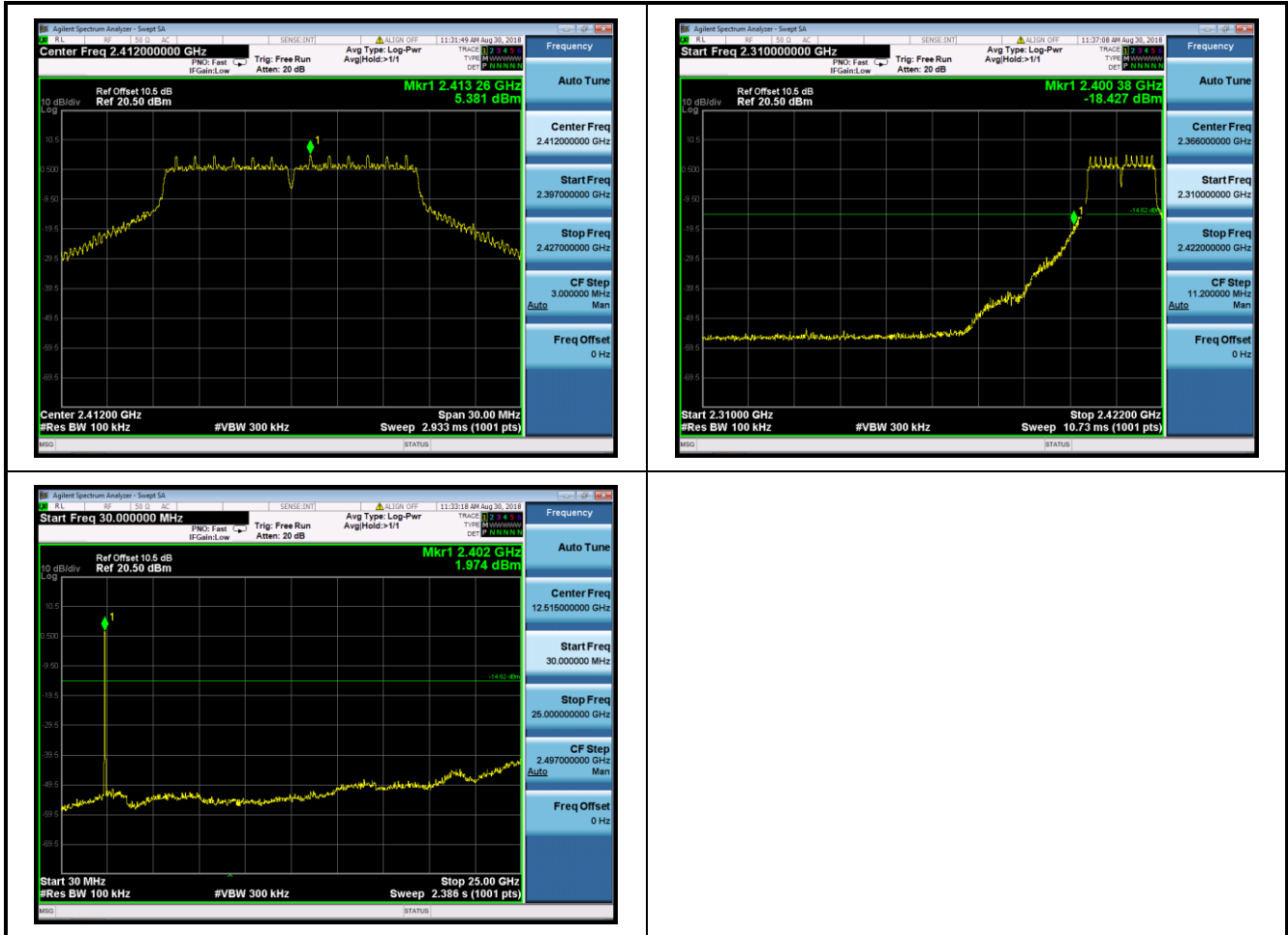



Mode 2: Transmit by 802.11g (2437MHz)

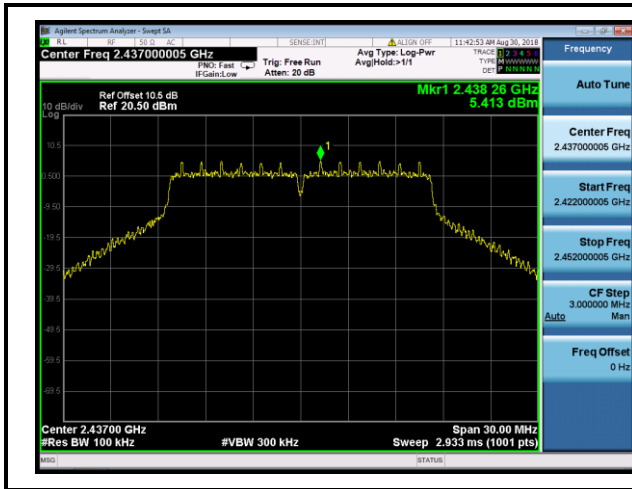

Mode 2: Transmit by 802.11g (2462MHz)

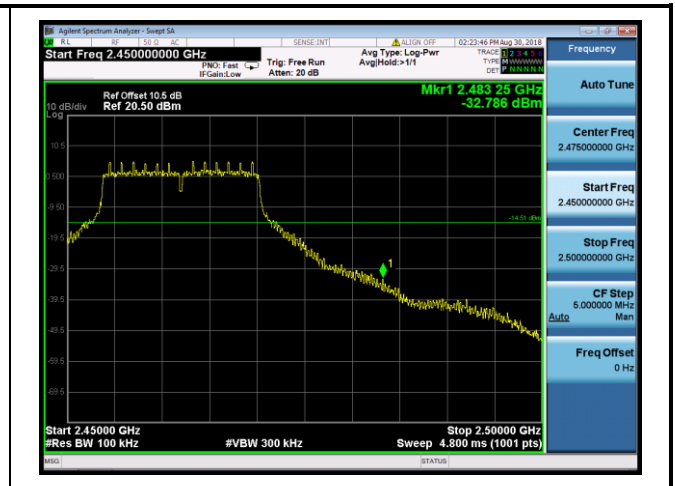
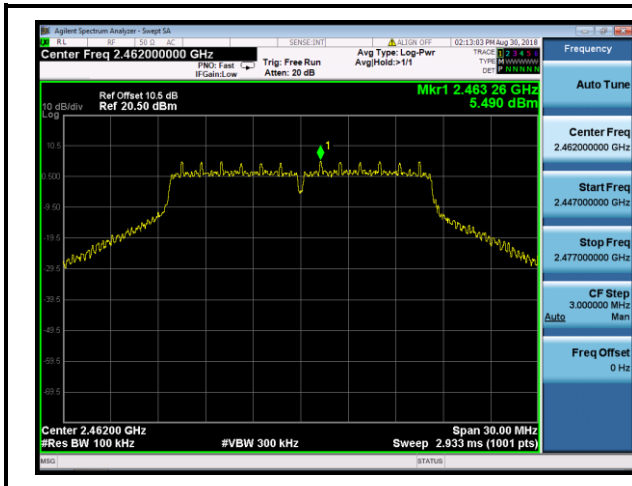



Test Item	:	Band-edge Compliance & Conducted Spurious Emissions
Test Mode	:	Mode 3: Transmit by 802.11n(20MHz)

Mode 3: Transmit by 802.11n(20MHz) (2412MHz)

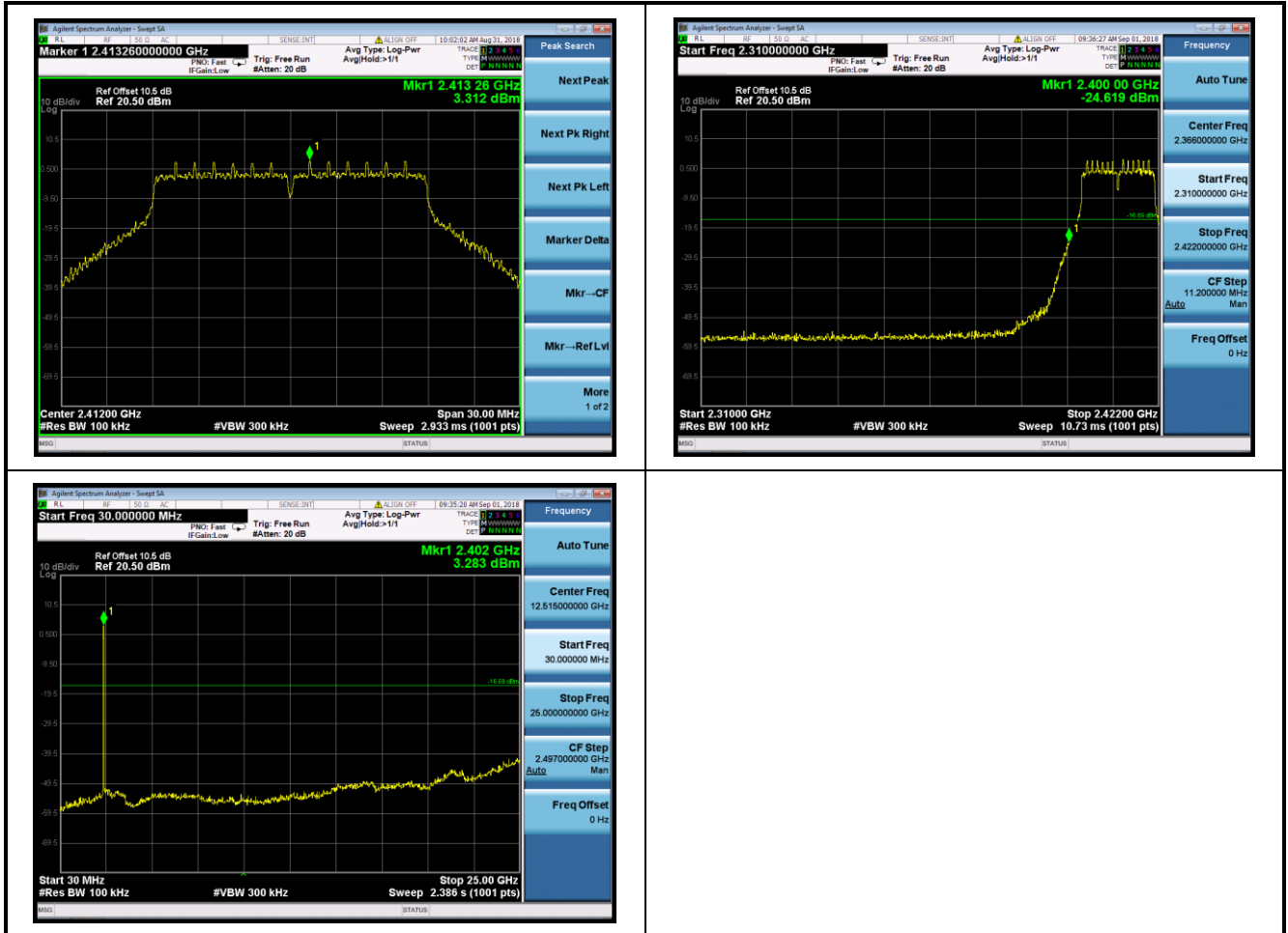



Mode 3: Transmit by 802.11n(20MHz) (2437MHz)

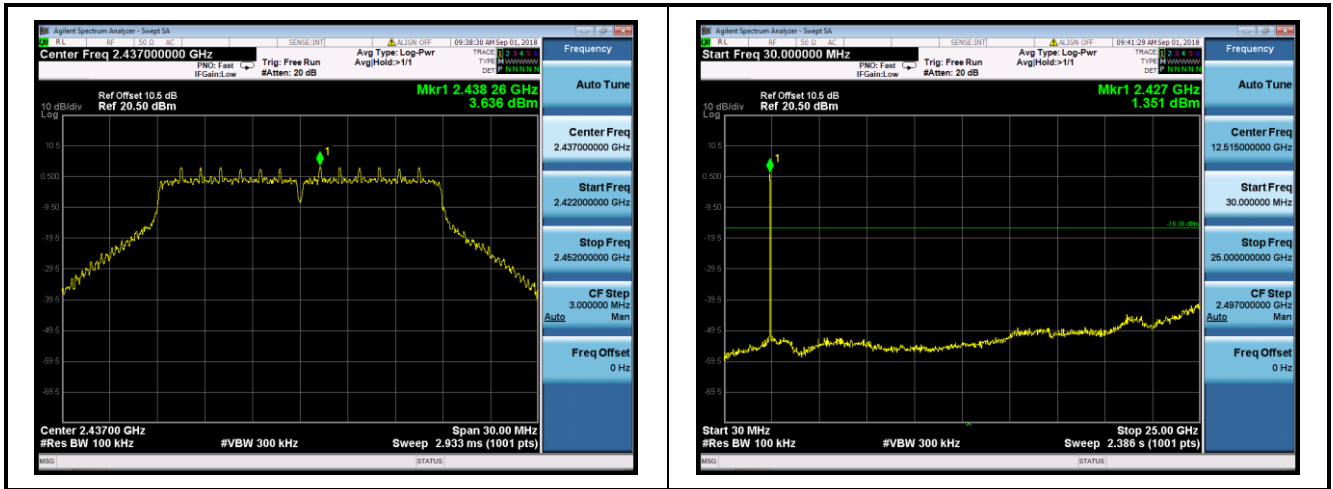

Mode 3: Transmit by 802.11n(20MHz) (2462MHz)

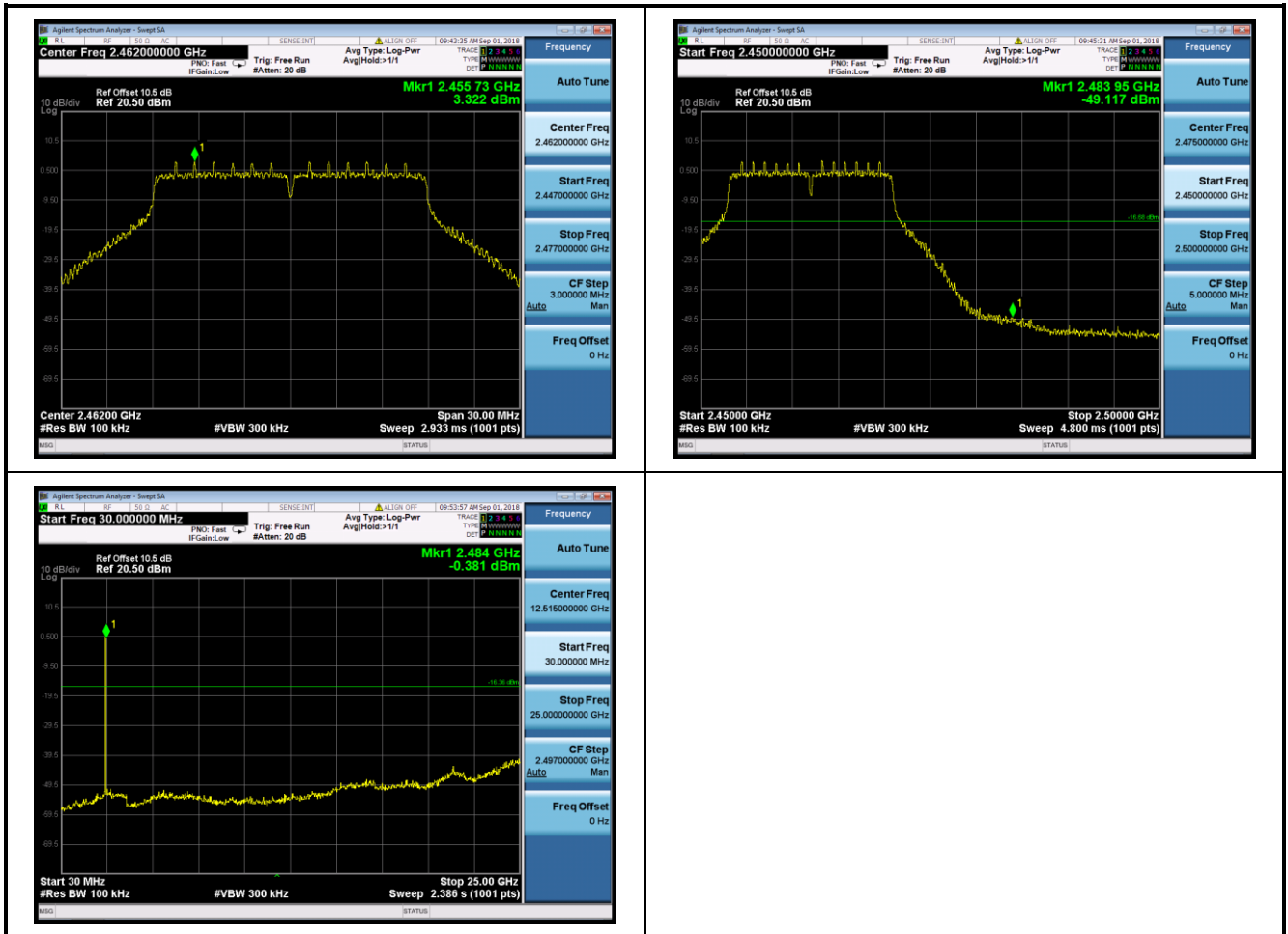



10. Radiated Emission Band Edge Measurement

10.1 Test Limit

Radiated emissions which fall in the restricted bands, as defined in Section 15.205(a) of FCC part 15, must also comply with the radiated emission limits specified in Section 15.209(a) of FCC part 15.

10.2 Test Standard

ANSI C63.10-2013 Section 6.10.5

10.3 Test Procedure

Peak Field Strength Measurements:

Analyzer center frequency was set to the frequency of the radiated spurious emission of interest

7. RBW=As specified in Table 1
8. VBW=3xRBW
9. Detector=Peak
10. Trace mode=Max hold
11. Sweep time=Auto couple
12. Allow the trace to stabilize

Table 1-RBW as a function of frequency

Frequency	RBW
9 ~ 150kHz	200 ~ 300Hz
0.15 ~ 30MHz	9 ~ 10kHz
30 ~ 1000MHz	100 ~ 120kHz
> 1000MHz	1MHz



AVE Field Strength Measurements:

Analyzer center frequency was set to the frequency of the radiated spurious emission of interest

7. RBW= 1MHz
8. VBW \geq 1/T
9. Detector=Peak
10. Trace mode=Max hold
11. Sweep time=Auto couple
12. Allow max hold to run for at least 50 times(1/duty cycle) trace

Do as an alternative, the instrument may be set to linear detector mode. Ensure that video filtering is applied in linear voltage domain (rather than in a log or dB domain). Some instruments require linear display mode in order to accomplish this. Others have a setting for Average-VBW Type, which can be set to "Voltage" regardless of the display mode

10.4 Test Setup Layout

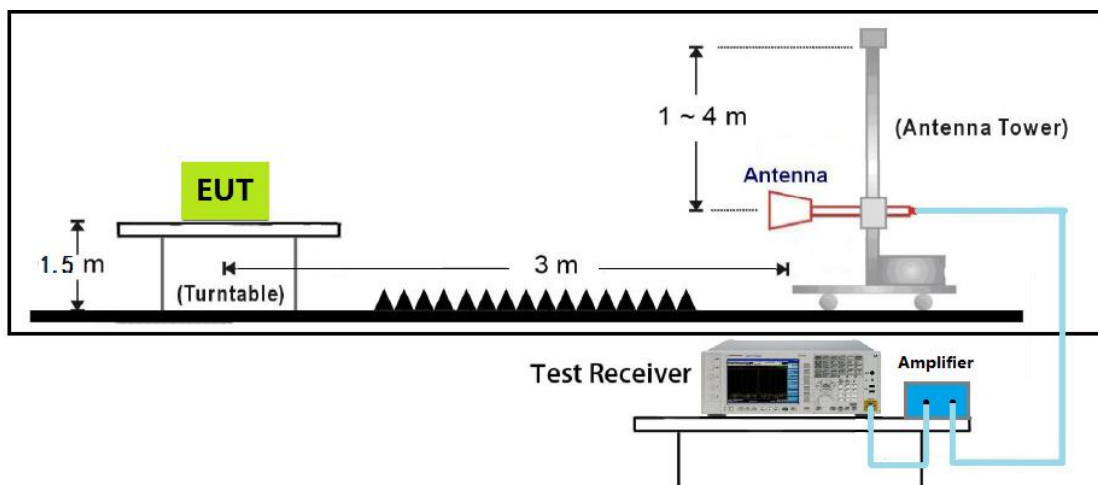



10.5 Test Result

Site: AC102	Time: 2018/09/01 - 15:10
Limit: FCC_Part15.209_RE(3m)	Margin: 0
Probe: N/A	Polarity: Horizontal
EUT: Remote Control Socket	Power:120V/60Hz
Note: Mode:Transmit 802.11b at 2412MHz	

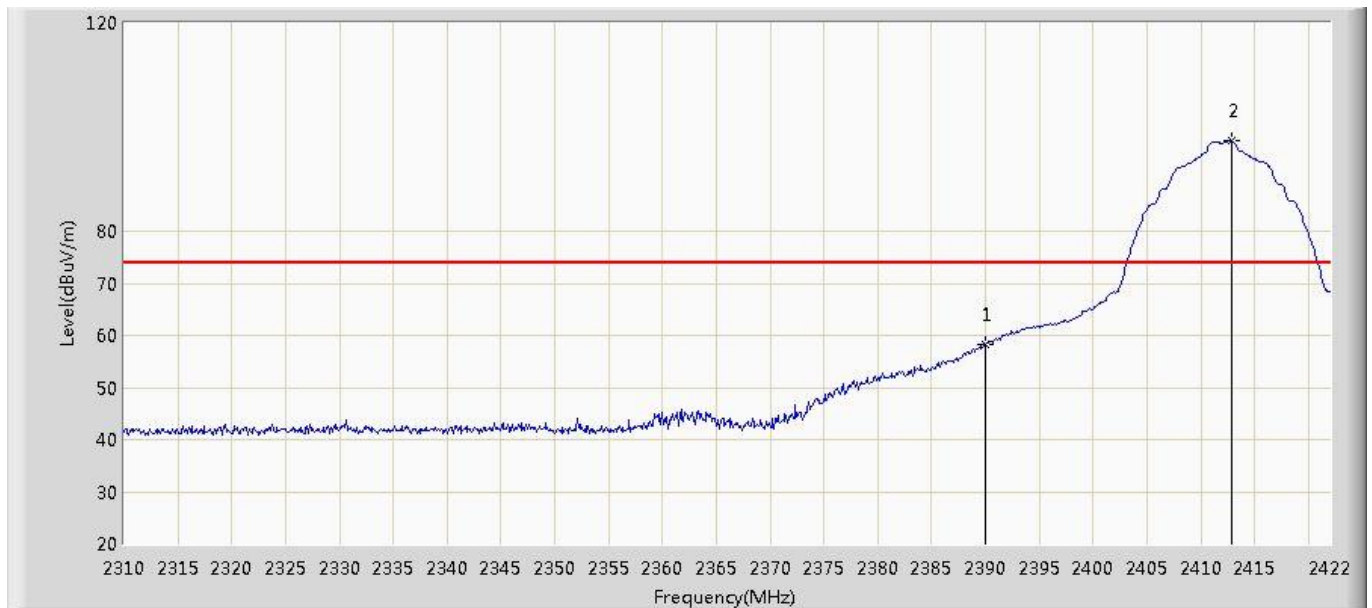

No	Mark	Frequency (MHz)	Measure Level (dBuV/m)	Reading Level (dBuV)	Over Limit (dB)	Limit (dBuV/m)	Factor (dB)	Type
1		2390.000	58.349	60.026	-15.651	74.000	-1.677	PK
2	*	2412.816	97.364	98.956	N/A	N/A	-1.592	PK

Note: Measure Level (dBμV/m) = Reading Level (dBμV) + Factor (dB)

Factor (dB) = Cable Loss (dB) + Antenna Factor (dB/m).



Site: AC102	Time: 2018/09/01 - 15:11
Limit: FCC_Part15.209_RE(3m)	Margin: 0
Probe: N/A	Polarity: Horizontal
EUT: Remote Control Socket	Power:120V/60Hz
Note: Mode:Transmit 802.11b at 2412MHz	



No	Mark	Frequency (MHz)	Measure Level (dBuV/m)	Reading Level (dBuV)	Over Limit (dB)	Limit (dBuV/m)	Factor (dB)	Type
1		2386.384	42.531	44.221	-11.469	54.000	-1.690	AV
2		2390.000	33.935	35.612	-20.065	54.000	-1.677	AV
3	*	2412.816	91.629	93.221	N/A	N/A	-1.592	AV

Note: Measure Level (dBμV/m) = Reading Level (dBμV) + Factor (dB)

Factor (dB) = Cable Loss (dB) + Antenna Factor (dB/m).



Site: AC102	Time: 2018/09/01 - 15:13
Limit: FCC_Part15.209_RE(3m)	Margin: 0
Probe: N/A	Polarity: Vertical
EUT: Remote Control Socket	Power:120V/60Hz
Note: Mode:Transmit 802.11b at 2412MHz	



No	Mark	Frequency (MHz)	Measure Level (dBuV/m)	Reading Level (dBuV)	Over Limit (dB)	Limit (dBuV/m)	Factor (dB)	Type
1		2390.000	65.215	66.892	-8.785	74.000	-1.677	PK
2	*	2413.040	105.296	106.888	N/A	N/A	-1.592	PK

Note: Measure Level (dBuV/m) = Reading Level (dBuV) + Factor (dB)

Factor (dB) = Cable Loss (dB) + Antenna Factor (dB/m).



Site: AC102	Time: 2018/09/01 - 15:14
Limit: FCC_Part15.209_RE(3m)	Margin: 0
Probe: N/A	Polarity: Vertical
EUT: Remote Control Socket	Power:120V/60Hz
Note: Mode:Transmit 802.11b at 2412MHz	



No	Mark	Frequency (MHz)	Measure Level (dBuV/m)	Reading Level (dBuV)	Over Limit (dB)	Limit (dBuV/m)	Factor (dB)	Type
1		2386.160	49.765	51.456	-4.235	54.000	-1.691	AV
2		2390.000	40.218	41.895	-13.782	54.000	-1.677	AV
3	*	2412.704	100.093	101.686	N/A	N/A	-1.593	AV

Note: Measure Level (dBμV/m) = Reading Level (dBμV) + Factor (dB)

Factor (dB) = Cable Loss (dB) + Antenna Factor (dB/m).



Site: AC102	Time: 2018/09/01 - 15:33
Limit: FCC_Part15.209_RE(3m)	Margin: 0
Probe: N/A	Polarity: Horizontal
EUT: Remote Control Socket	Power:120V/60Hz
Note: Mode:Transmit 802.11b at 2462MHz	



No	Mark	Frequency (MHz)	Measure Level (dBuV/m)	Reading Level (dBuV)	Over Limit (dB)	Limit (dBuV/m)	Factor (dB)	Type
1	*	2462.896	96.894	98.302	N/A	N/A	-1.408	PK
2		2483.500	59.564	60.895	-14.436	74.000	-1.331	PK

Note: Measure Level (dBuV/m) = Reading Level (dBuV) + Factor (dB)

Factor (dB) = Cable Loss (dB) + Antenna Factor (dB/m).



Site: AC102	Time: 2018/09/01 - 15:35
Limit: FCC_Part15.209_RE(3m)	Margin: 0
Probe: N/A	Polarity: Horizontal
EUT: Remote Control Socket	Power:120V/60Hz
Note: Mode:Transmit 802.11b at 2462MHz	

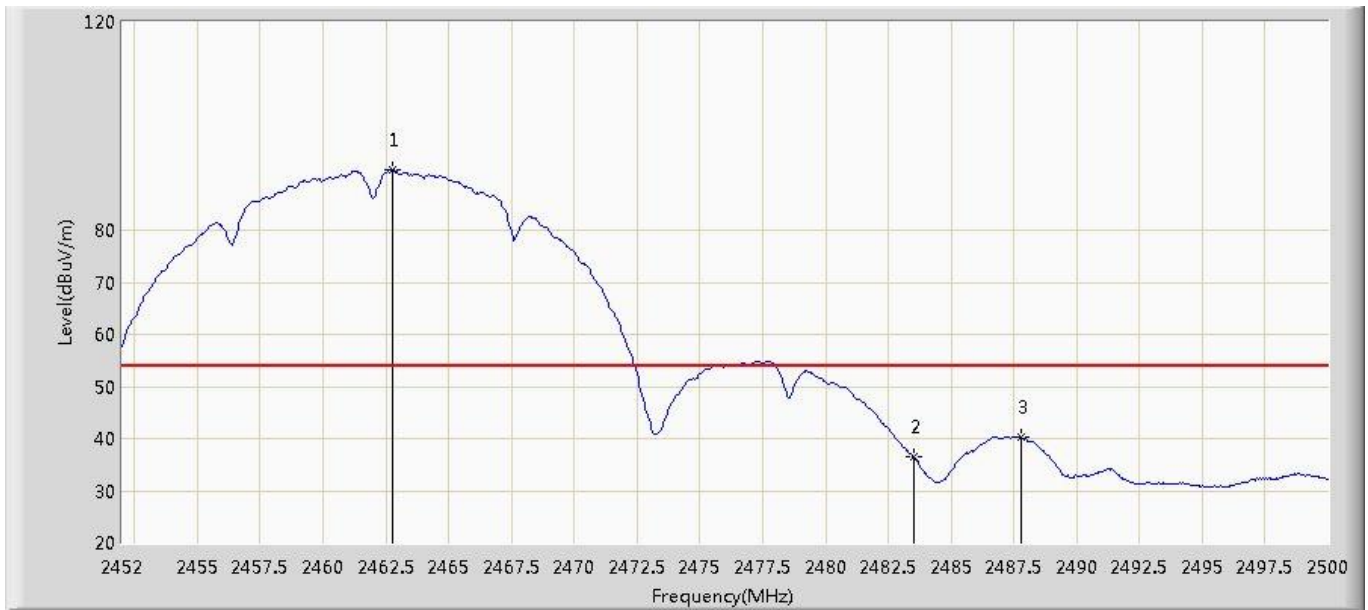

No	Mark	Frequency (MHz)	Measure Level (dBuV/m)	Reading Level (dBuV)	Over Limit (dB)	Limit (dBuV/m)	Factor (dB)	Type
1	*	2462.752	91.627	93.035	N/A	N/A	-1.408	AV
2		2483.500	36.561	37.892	-17.439	54.000	-1.331	AV
3		2487.760	40.376	41.691	-13.624	54.000	-1.315	AV

Note: Measure Level (dBμV/m) = Reading Level (dBμV) + Factor (dB)

Factor (dB) = Cable Loss (dB) + Antenna Factor (dB/m).



Site: AC102	Time: 2018/09/01 - 15:36
Limit: FCC_Part15.209_RE(3m)	Margin: 0
Probe: N/A	Polarity: Vertical
EUT: Remote Control Socket	Power:120V/60Hz
Note: Mode:Transmit 802.11b at 2462MHz	

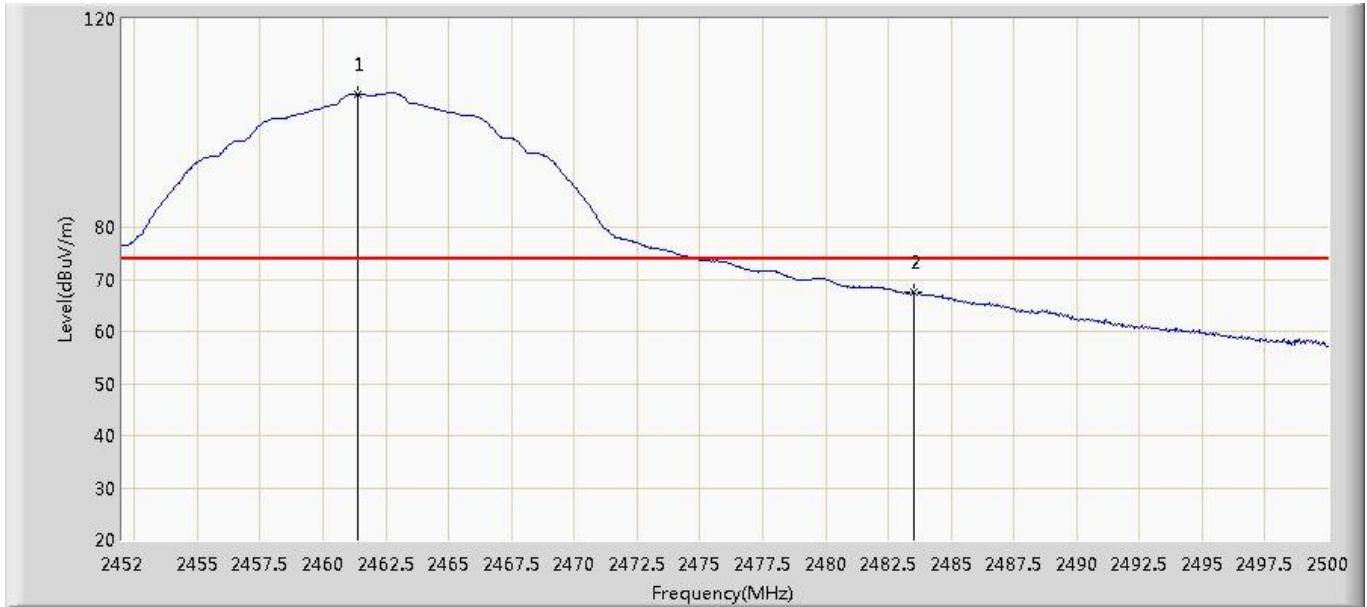

No	Mark	Frequency (MHz)	Measure Level (dBuV/m)	Reading Level (dBuV)	Over Limit (dB)	Limit (dBuV/m)	Factor (dB)	Type
1	*	2461.360	105.565	106.978	N/A	N/A	-1.413	PK
2		2483.500	67.393	68.724	-6.607	74.000	-1.331	PK

Note: Measure Level (dBuV/m) = Reading Level (dBuV) + Factor (dB)

Factor (dB) = Cable Loss (dB) + Antenna Factor (dB/m).



Site: AC102	Time: 2018/09/01 - 15:39
Limit: FCC_Part15.209_RE(3m)	Margin: 0
Probe: N/A	Polarity: Vertical
EUT: Remote Control Socket	Power:120V/60Hz
Note: Mode:Transmit 802.11b at 2462MHz	



No	Mark	Frequency (MHz)	Measure Level (dBuV/m)	Reading Level (dBuV)	Over Limit (dB)	Limit (dBuV/m)	Factor (dB)	Type
1	*	2462.656	100.291	101.699	N/A	N/A	-1.408	AV
2		2483.500	44.399	45.730	-9.601	54.000	-1.331	AV
3		2487.664	49.064	50.379	-4.936	54.000	-1.315	AV

Note: Measure Level (dBμV/m) = Reading Level (dBμV) + Factor (dB)

Factor (dB) = Cable Loss (dB) + Antenna Factor (dB/m).



Site: AC102	Time: 2018/09/01 - 16:30
Limit: FCC_Part15.209_RE(3m)	Margin: 0
Probe: N/A	Polarity: Horizontal
EUT: Remote Control Socket	Power:120V/60Hz
Note: Mode:Transmit 802.11g at 2412MHz	



No	Mark	Frequency (MHz)	Measure Level (dBuV/m)	Reading Level (dBuV)	Over Limit (dB)	Limit (dBuV/m)	Factor (dB)	Type
1		2390.000	63.344	65.021	-10.656	74.000	-1.677	PK
2	*	2416.064	98.753	100.333	N/A	N/A	-1.580	PK

Note: Measure Level (dBuV/m) = Reading Level (dBuV) + Factor (dB)

Factor (dB) = Cable Loss (dB) + Antenna Factor (dB/m).



Site: AC102	Time: 2018/09/01 - 16:33
Limit: FCC_Part15.209_RE(3m)	Margin: 0
Probe: N/A	Polarity: Horizontal
EUT: Remote Control Socket	Power:120V/60Hz
Note: Mode:Transmit 802.11g at 2412MHz	

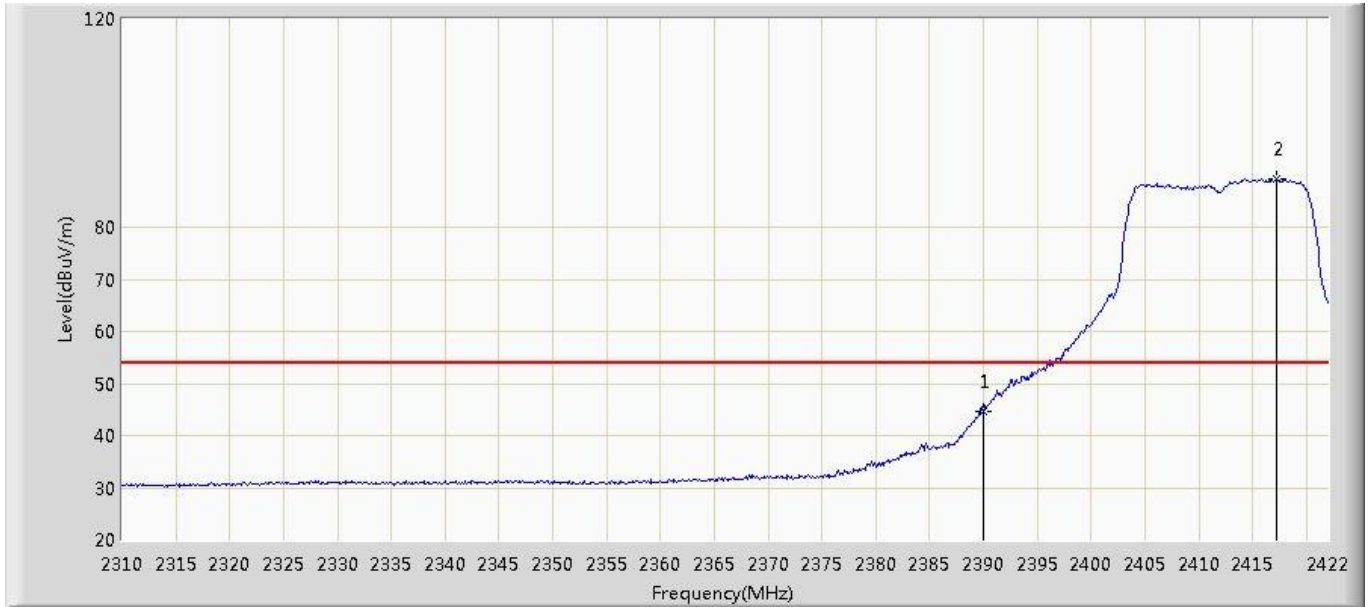

No	Mark	Frequency (MHz)	Measure Level (dBuV/m)	Reading Level (dBuV)	Over Limit (dB)	Limit (dBuV/m)	Factor (dB)	Type
1		2390.000	44.642	46.319	-9.358	54.000	-1.677	AV
2	*	2417.184	89.314	90.890	N/A	N/A	-1.576	AV

Note: Measure Level (dBuV/m) = Reading Level (dBuV) + Factor (dB)

Factor (dB) = Cable Loss (dB) + Antenna Factor (dB/m).



Site: AC102	Time: 2018/09/01 - 16:33
Limit: FCC_Part15.209_RE(3m)	Margin: 0
Probe: N/A	Polarity: Vertical
EUT: Remote Control Socket	Power:120V/60Hz
Note: Mode:Transmit 802.11g at 2412MHz	



No	Mark	Frequency (MHz)	Measure Level (dBuV/m)	Reading Level (dBuV)	Over Limit (dB)	Limit (dBuV/m)	Factor (dB)	Type
1		2390.000	69.511	71.188	-4.489	74.000	-1.677	PK
2	*	2414.944	106.607	108.192	N/A	N/A	-1.585	PK

Note: Measure Level (dBuV/m) = Reading Level (dBuV) + Factor (dB)

Factor (dB) = Cable Loss (dB) + Antenna Factor (dB/m).



Site: AC102	Time: 2018/09/01 - 16:35
Limit: FCC_Part15.209_RE(3m)	Margin: 0
Probe: N/A	Polarity: Vertical
EUT: Remote Control Socket	Power:120V/60Hz
Note: Mode:Transmit 802.11g at 2412MHz	

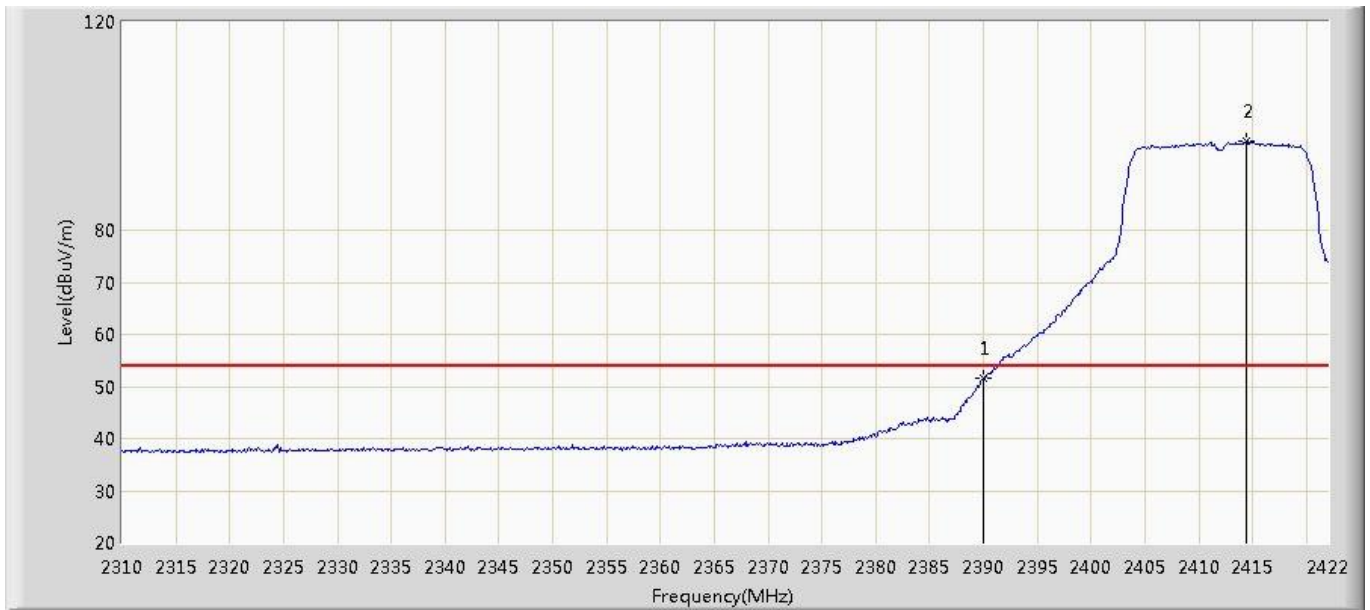

No	Mark	Frequency (MHz)	Measure Level (dBuV/m)	Reading Level (dBuV)	Over Limit (dB)	Limit (dBuV/m)	Factor (dB)	Type
1		2390.000	51.499	53.176	-2.501	54.000	-1.677	AV
2	*	2414.384	96.972	98.559	N/A	N/A	-1.587	AV

Note: Measure Level (dBuV/m) = Reading Level (dBuV) + Factor (dB)

Factor (dB) = Cable Loss (dB) + Antenna Factor (dB/m).



Site: AC102	Time: 2018/09/01 - 16:45
Limit: FCC_Part15.209_RE(3m)	Margin: 0
Probe: N/A	Polarity: Horizontal
EUT: Remote Control Socket	Power:120V/60Hz
Note: Mode:Transmit 802.11g at 2462MHz	

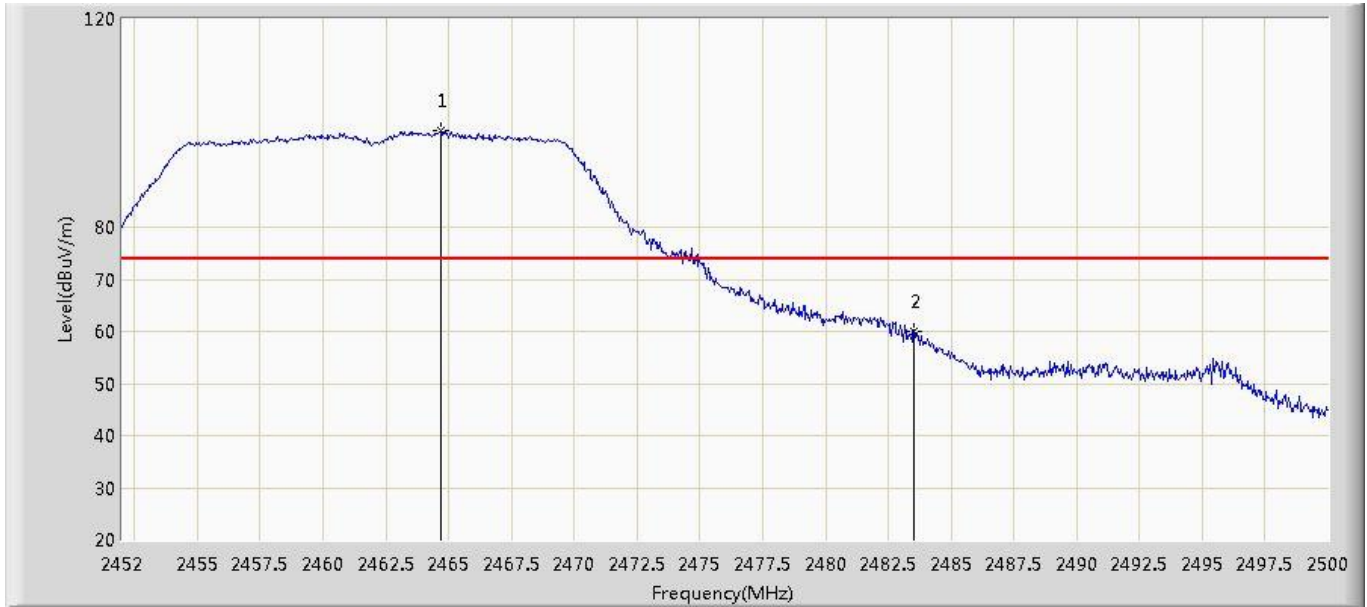

No	Mark	Frequency (MHz)	Measure Level (dBuV/m)	Reading Level (dBuV)	Over Limit (dB)	Limit (dBuV/m)	Factor (dB)	Type
1	*	2464.672	98.409	99.810	N/A	N/A	-1.401	PK
2		2483.500	60.073	61.404	-13.927	74.000	-1.331	PK

Note: Measure Level (dBuV/m) = Reading Level (dBuV) + Factor (dB)

Factor (dB) = Cable Loss (dB) + Antenna Factor (dB/m).



Site: AC102	Time: 2018/09/01 - 16:46
Limit: FCC_Part15.209_RE(3m)	Margin: 0
Probe: N/A	Polarity: Horizontal
EUT: Remote Control Socket	Power:120V/60Hz
Note: Mode:Transmit 802.11g at 2462MHz	

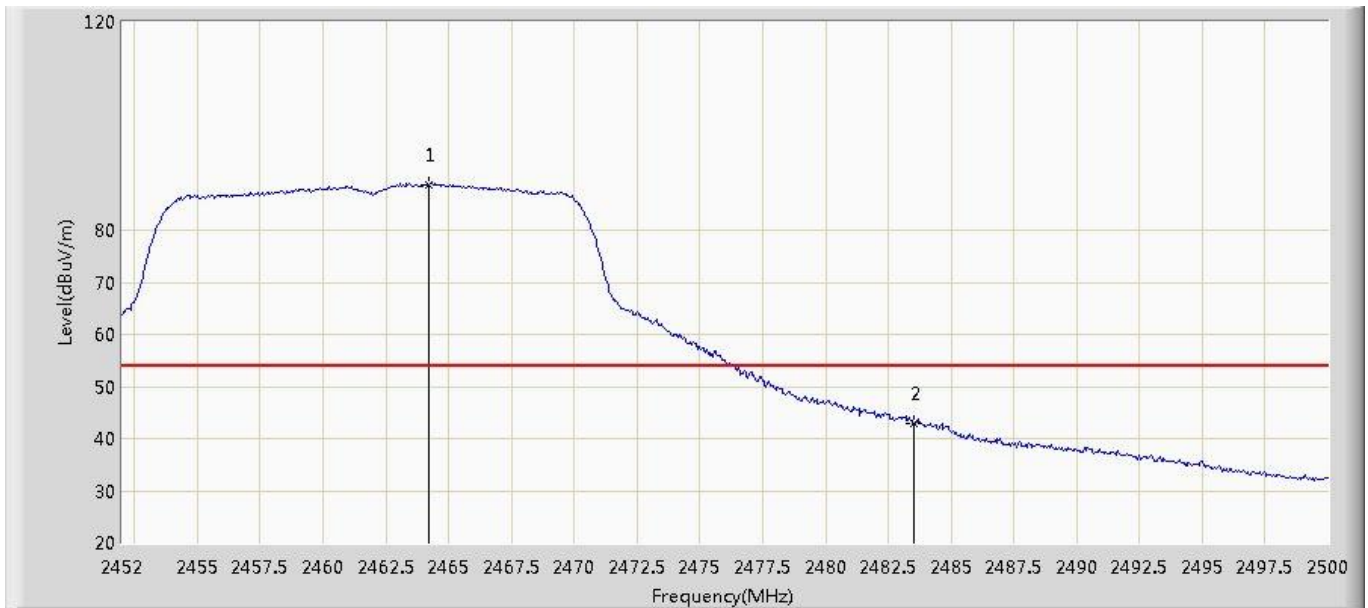

No	Mark	Frequency (MHz)	Measure Level (dBuV/m)	Reading Level (dBuV)	Over Limit (dB)	Limit (dBuV/m)	Factor (dB)	Type
1	*	2464.240	88.799	90.202	N/A	N/A	-1.403	AV
2		2483.500	42.967	44.298	-11.033	54.000	-1.331	AV

Note: Measure Level (dBuV/m) = Reading Level (dBuV) + Factor (dB)

Factor (dB) = Cable Loss (dB) + Antenna Factor (dB/m).



Site: AC102	Time: 2018/09/01 - 16:48
Limit: FCC_Part15.209_RE(3m)	Margin: 0
Probe: N/A	Polarity: Vertical
EUT: Remote Control Socket	Power:120V/60Hz
Note: Mode:Transmit 802.11g at 2462MHz	

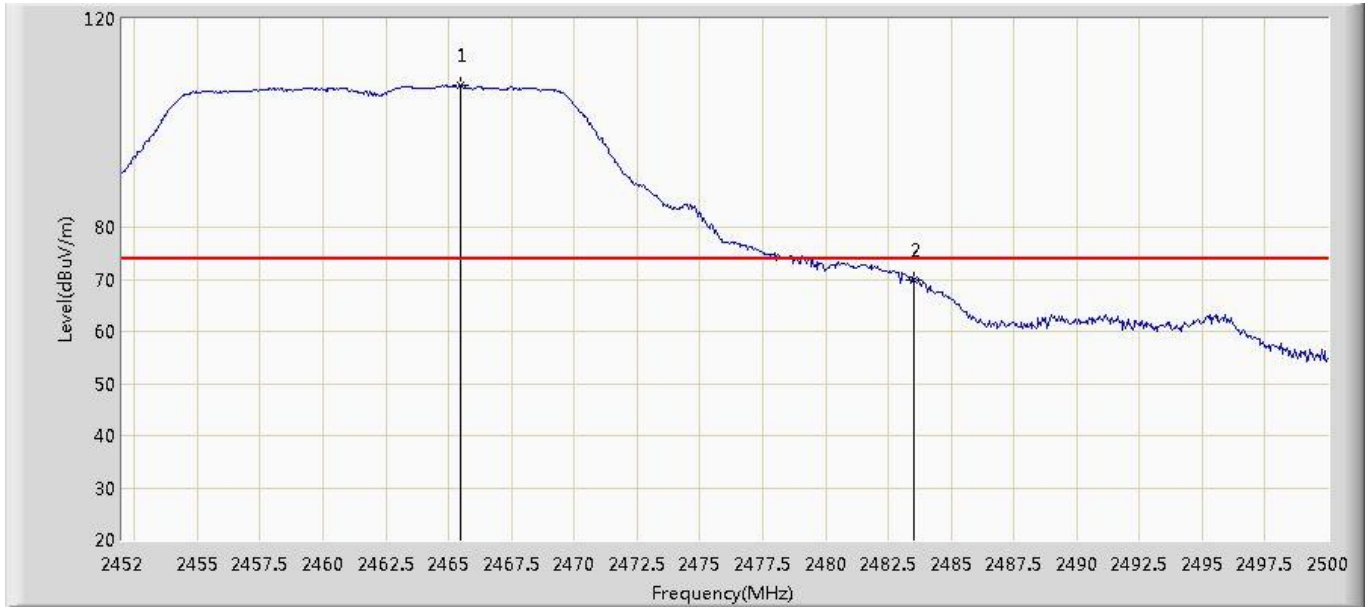

No	Mark	Frequency (MHz)	Measure Level (dBuV/m)	Reading Level (dBuV)	Over Limit (dB)	Limit (dBuV/m)	Factor (dB)	Type
1	*	2465.488	107.160	108.558	N/A	N/A	-1.398	PK
2		2483.500	69.860	71.191	-4.140	74.000	-1.331	PK

Note: Measure Level (dBuV/m) = Reading Level (dBuV) + Factor (dB)

Factor (dB) = Cable Loss (dB) + Antenna Factor (dB/m).



Site: AC102	Time: 2018/09/01 - 16:50
Limit: FCC_Part15.209_RE(3m)	Margin: 0
Probe: N/A	Polarity: Vertical
EUT: Remote Control Socket	Power:120V/60Hz
Note: Mode:Transmit 802.11g at 2462MHz	

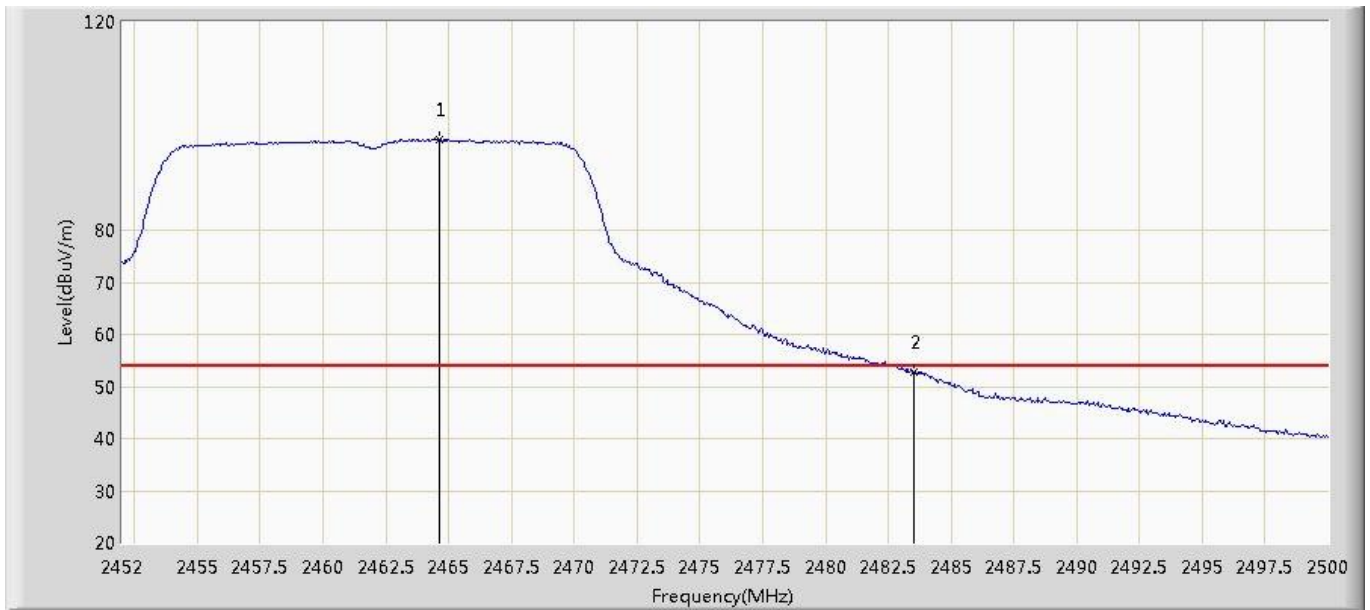

No	Mark	Frequency (MHz)	Measure Level (dBuV/m)	Reading Level (dBuV)	Over Limit (dB)	Limit (dBuV/m)	Factor (dB)	Type
1	*	2464.624	97.495	98.896	N/A	N/A	-1.401	AV
2		2483.500	52.751	54.082	-1.249	54.000	-1.331	AV

Note: Measure Level (dBuV/m) = Reading Level (dBuV) + Factor (dB)

Factor (dB) = Cable Loss (dB) + Antenna Factor (dB/m).



Site: AC102	Time: 2018/09/01 - 17:03
Limit: FCC_Part15.209_RE(3m)	Margin: 0
Probe: N/A	Polarity: Horizontal
EUT: Remote Control Socket	Power:120V/60Hz
Note: Mode:Transmit 802.11n(20MHz) at 2412MHz	



No	Mark	Frequency (MHz)	Measure Level (dBuV/m)	Reading Level (dBuV)	Over Limit (dB)	Limit (dBuV/m)	Factor (dB)	Type
1		2389.520	56.728	58.406	-17.272	74.000	-1.678	PK
2	*	2416.512	97.010	98.589	N/A	N/A	-1.579	PK

Note: Measure Level (dBuV/m) = Reading Level (dBuV) + Factor (dB)

Factor (dB) = Cable Loss (dB) + Antenna Factor (dB/m).



Site: AC102	Time: 2018/09/01 - 17:07
Limit: FCC_Part15.209_RE(3m)	Margin: 0
Probe: N/A	Polarity: Horizontal
EUT: Remote Control Socket	Power:120V/60Hz
Note: Mode:Transmit 802.11n(20MHz) at 2412MHz	

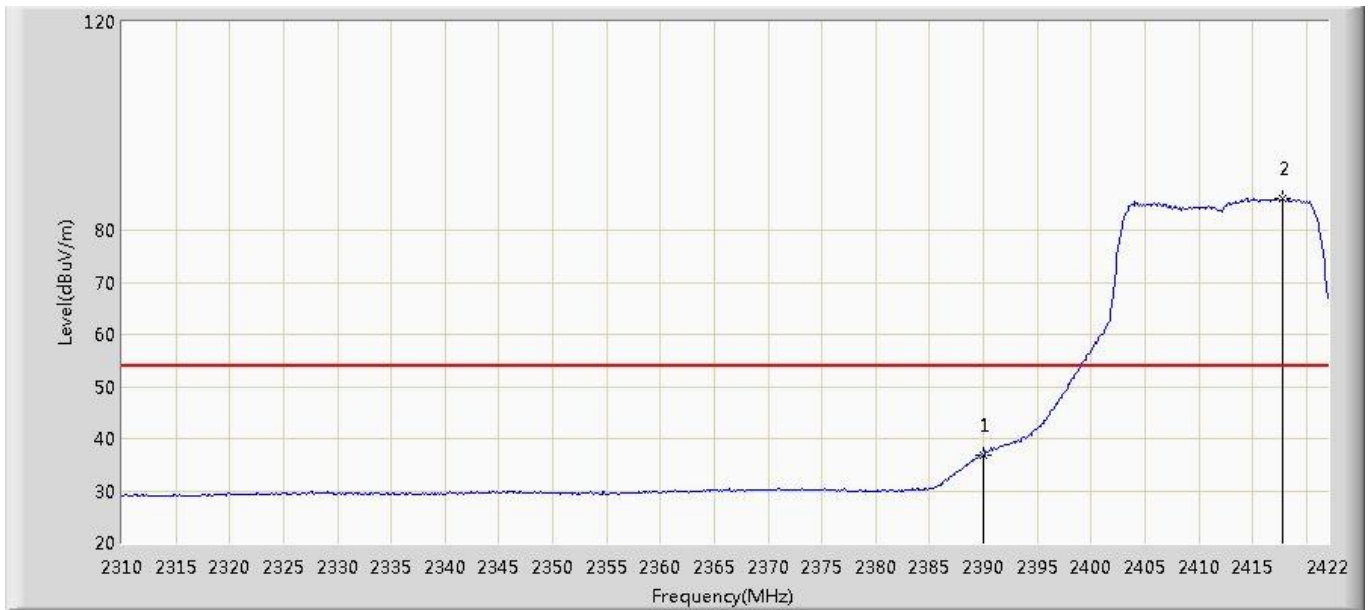

No	Mark	Frequency (MHz)	Measure Level (dBuV/m)	Reading Level (dBuV)	Over Limit (dB)	Limit (dBuV/m)	Factor (dB)	Type
1		2390.000	36.941	38.618	-17.059	54.000	-1.677	AV
2	*	2417.744	86.009	87.583	N/A	N/A	-1.574	AV

Note: Measure Level (dBμV/m) = Reading Level (dBμV) + Factor (dB)

Factor (dB) = Cable Loss (dB) + Antenna Factor (dB/m).



Site: AC102	Time: 2018/09/01 - 17:08
Limit: FCC_Part15.209_RE(3m)	Margin: 0
Probe: N/A	Polarity: Vertical
EUT: Remote Control Socket	Power:120V/60Hz
Note: Mode:Transmit 802.11n(20MHz) at 2412MHz	



No	Mark	Frequency (MHz)	Measure Level (dBuV/m)	Reading Level (dBuV)	Over Limit (dB)	Limit (dBuV/m)	Factor (dB)	Type
1		2390.000	62.283	63.960	-11.717	74.000	-1.677	PK
2	*	2414.384	105.190	106.777	N/A	N/A	-1.587	PK

Note: Measure Level (dBuV/m) = Reading Level (dBuV) + Factor (dB)

Factor (dB) = Cable Loss (dB) + Antenna Factor (dB/m).



Site: AC102	Time: 2018/09/01 - 17:11
Limit: FCC_Part15.209_RE(3m)	Margin: 0
Probe: N/A	Polarity: Vertical
EUT: Remote Control Socket	Power:120V/60Hz
Note: Mode:Transmit 802.11n(20MHz) at 2412MHz	

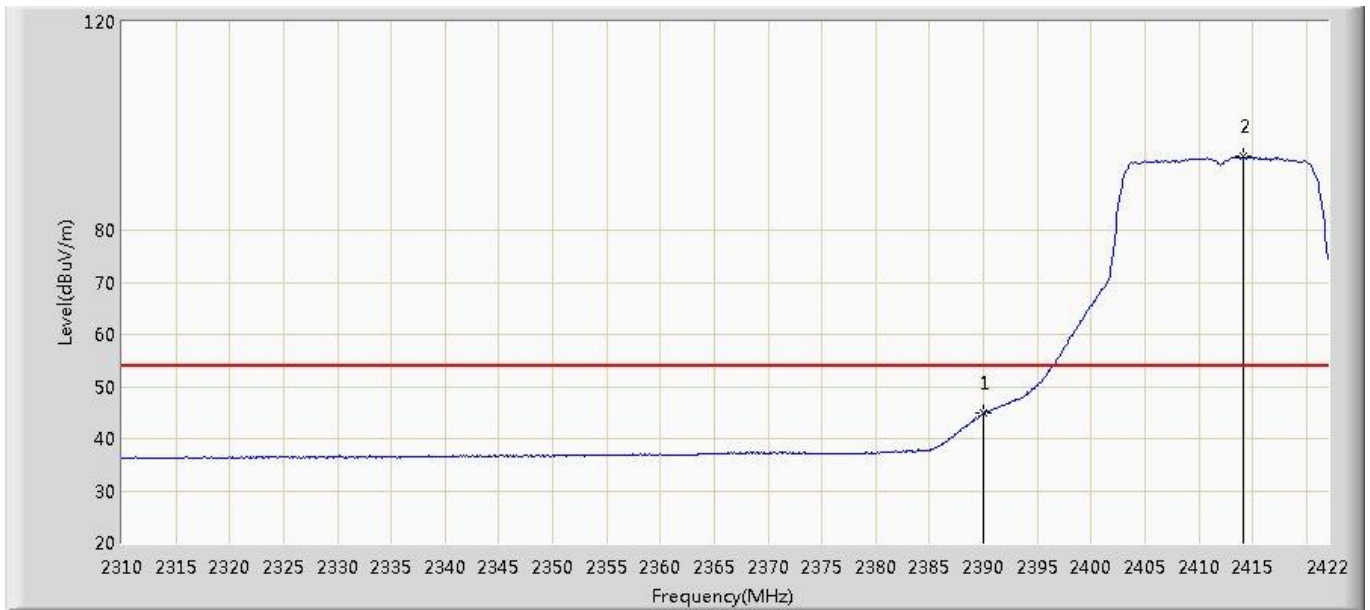

No	Mark	Frequency (MHz)	Measure Level (dBuV/m)	Reading Level (dBuV)	Over Limit (dB)	Limit (dBuV/m)	Factor (dB)	Type
1		2390.000	44.816	46.493	-9.184	54.000	-1.677	AV
2	*	2414.160	94.089	95.676	N/A	N/A	-1.587	AV

Note: Measure Level (dBuV/m) = Reading Level (dBuV) + Factor (dB)

Factor (dB) = Cable Loss (dB) + Antenna Factor (dB/m).



Site: AC102	Time: 2018/09/01 - 17:20
Limit: FCC_Part15.209_RE(3m)	Margin: 0
Probe: N/A	Polarity: Horizontal
EUT: Remote Control Socket	Power:120V/60Hz
Note: Mode:Transmit 802.11n(20MHz) at 2462MHz	

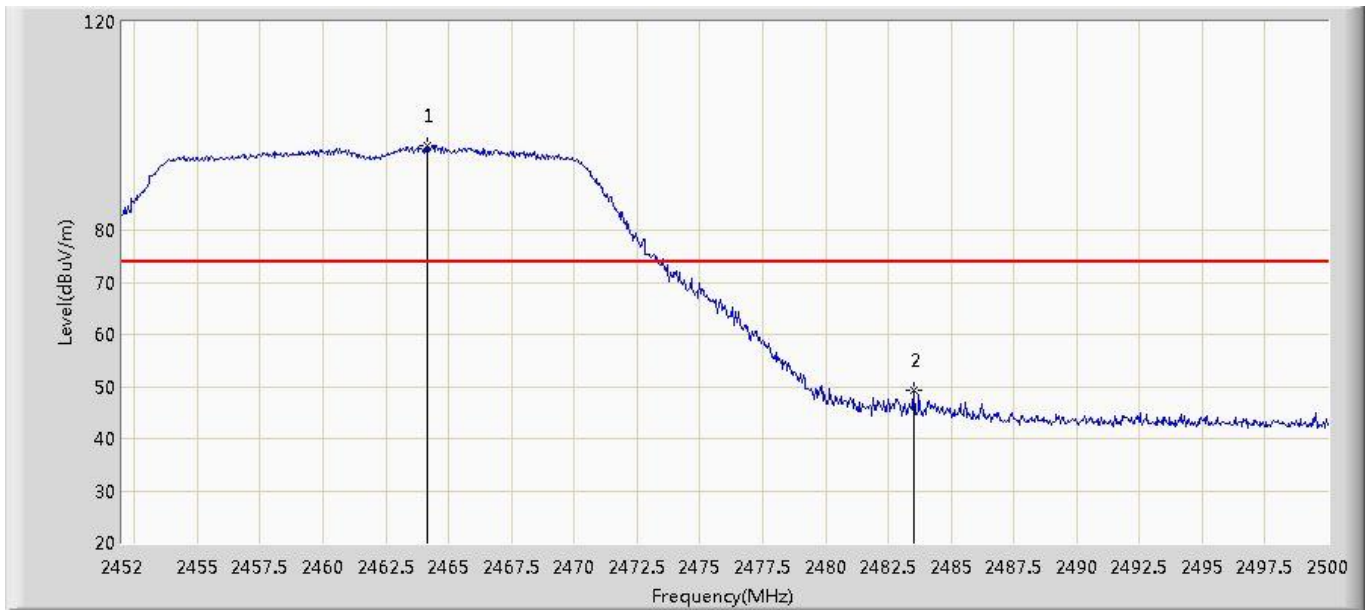

No	Mark	Frequency (MHz)	Measure Level (dBuV/m)	Reading Level (dBuV)	Over Limit (dB)	Limit (dBuV/m)	Factor (dB)	Type
1	*	2464.144	96.277	97.680	N/A	N/A	-1.403	PK
2		2483.536	49.202	50.532	-24.798	74.000	-1.330	PK

Note: Measure Level (dBμV/m) = Reading Level (dBμV) + Factor (dB)

Factor (dB) = Cable Loss (dB) + Antenna Factor (dB/m).



Site: AC102	Time: 2018/09/01 - 17:23
Limit: FCC_Part15.209_RE(3m)	Margin: 0
Probe: N/A	Polarity: Horizontal
EUT: Remote Control Socket	Power:120V/60Hz
Note: Mode:Transmit 802.11n(20MHz) at 2462MHz	

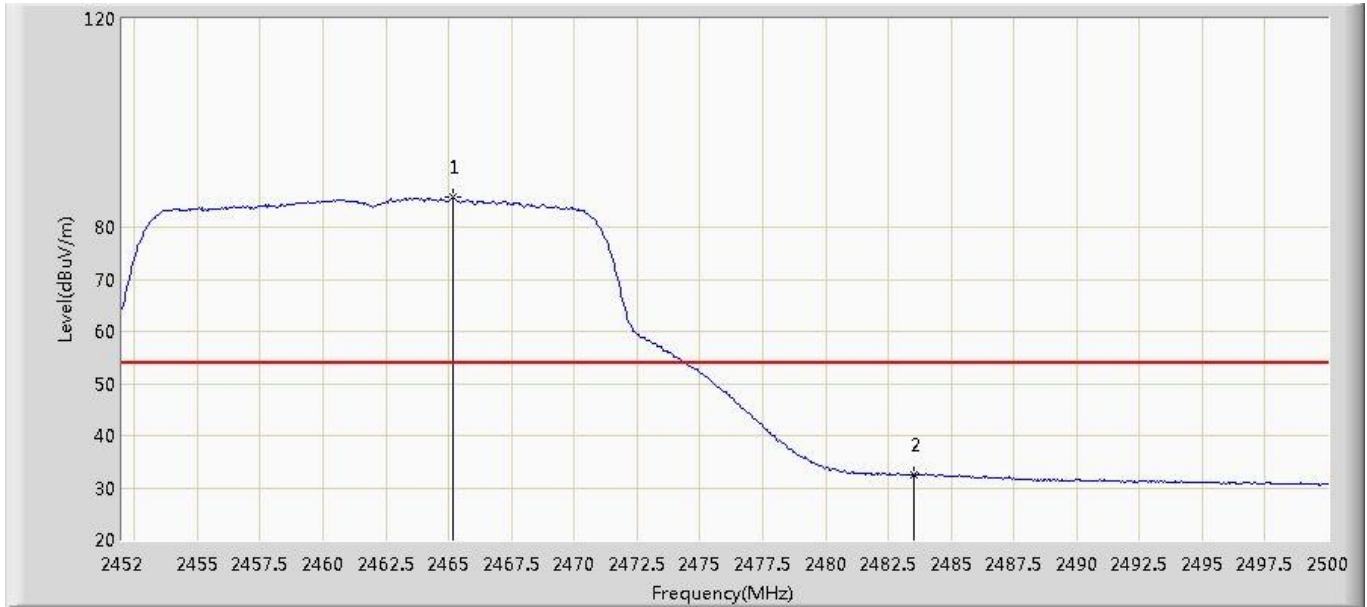

No	Mark	Frequency (MHz)	Measure Level (dBuV/m)	Reading Level (dBuV)	Over Limit (dB)	Limit (dBuV/m)	Factor (dB)	Type
1	*	2465.152	85.722	87.121	N/A	N/A	-1.399	AV
2		2483.500	32.532	33.863	-21.468	54.000	-1.331	AV

Note: Measure Level (dBuV/m) = Reading Level (dBuV) + Factor (dB)

Factor (dB) = Cable Loss (dB) + Antenna Factor (dB/m).



Site: AC102	Time: 2018/09/01 - 17:23
Limit: FCC_Part15.209_RE(3m)	Margin: 0
Probe: N/A	Polarity: Vertical
EUT: Remote Control Socket	Power:120V/60Hz
Note: Mode:Transmit 802.11n(20MHz) at 2462MHz	

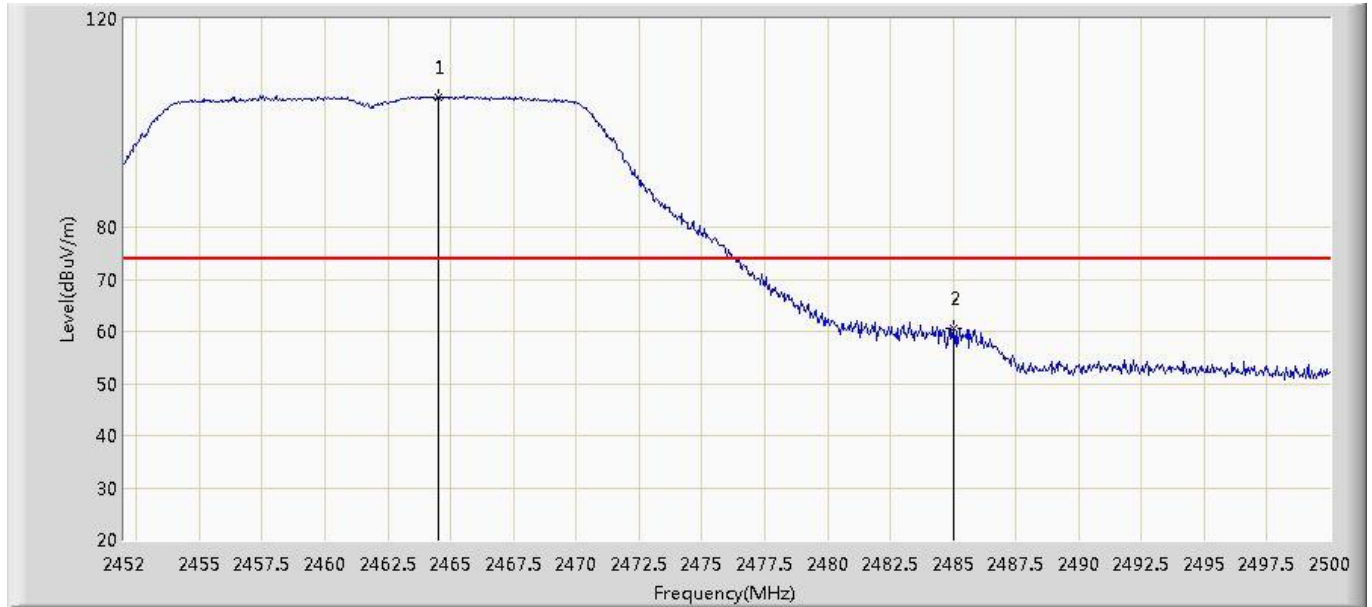

No	Mark	Frequency (MHz)	Measure Level (dBuV/m)	Reading Level (dBuV)	Over Limit (dB)	Limit (dBuV/m)	Factor (dB)	Type
1	*	2464.528	104.977	106.378	N/A	N/A	-1.401	PK
2		2485.024	60.662	61.987	-13.338	74.000	-1.325	PK

Note: Measure Level (dBuV/m) = Reading Level (dBuV) + Factor (dB)

Factor (dB) = Cable Loss (dB) + Antenna Factor (dB/m).



Site: AC102	Time: 2017/11/20 - 19:32
Limit: FCC_Part15.209_RE(3m)	Margin: 0
Probe: N/A	Polarity: Vertical
EUT: Remote Control Socket	Power:120V/60Hz
Note: Mode:Transmit 802.11n(20MHz) at 2462MHz	



No	Mark	Frequency (MHz)	Measure Level (dBuV/m)	Reading Level (dBuV)	Over Limit (dB)	Limit (dBuV/m)	Factor (dB)	Type
1	*	2464.576	94.480	95.881	N/A	N/A	-1.401	AV
2		2483.500	42.660	43.991	-11.340	54.000	-1.331	AV

Note: Measure Level (dBuV/m) = Reading Level (dBuV) + Factor (dB)

Factor (dB) = Cable Loss (dB) + Antenna Factor (dB/m).

The End