

TEST REPORT

Product : WIFI Module
Trade mark : GSD
Model/Type reference : W7HM1200
Serial Number : N/A
Report Number : EED32H001315
FCC ID : 2AC23W7HM1200
Date of Issue : Oct. 09, 2015
Test Standards : 47 CFR Part 15Subpart C (2014)
Test result : PASS

Prepared for:

Hui Zhou Gaoshengda Technology Co., LTD
NO.75 Zhongkai Development Area, Huizhou, Guangdong

Prepared by:

Centre Testing International Group Co., Ltd.
Hongwei Industrial Zone, Bao'an 70 District,
Shenzhen, Guangdong, China
TEL: +86-755-3368 3668
FAX: +86-755-3368 3385

Tested by:

Ware Xin

Reviewed by:

Fmen-li

Approved by:

Sheek Luo

Date:

Oct. 09, 2015

Sheek Luo
Lab supervisor

Check No.:2212834018



2 Version

Version No.	Date	Description
00	Oct. 09, 2015	Original

3 Test Summary

Test Item	Test Requirement	Test method	Result
Antenna Requirement	47 CFR Part 15 Subpart C Section 15.203/15.247 (c)	ANSI C63.10-2013	PASS
AC Power Line Conducted Emission	47 CFR Part 15 Subpart C Section 15.207	ANSI C63.10-2013	PASS
Conducted Peak Output Power	47 CFR Part 15 Subpart C Section 15.247 (b)(3)	ANSI C63.10-2013	PASS
6dB Occupied Bandwidth	47 CFR Part 15 Subpart C Section 15.247 (a)(2)	ANSI C63.10-2013	PASS
Power Spectral Density	47 CFR Part 15 Subpart C Section 15.247 (e)	ANSI C63.10-2013	PASS
Band-edge for RF Conducted Emissions	47 CFR Part 15 Subpart C Section 15.247(d)	ANSI C63.10-2013	PASS
RF Conducted Spurious Emissions	47 CFR Part 15 Subpart C Section 15.247(d)	ANSI C63.10-2013	PASS
Radiated Spurious Emissions	47 CFR Part 15 Subpart C Section 15.205/15.209	ANSI C63.10-2013	PASS
Restricted bands around fundamental frequency (Radiated Emission)	47 CFR Part 15 Subpart C Section 15.205/15.209	ANSI C63.10-2013	PASS

Remark: Test according to ANSI C63.4-2014 & ANSI C63.10-2013.

The tested sample(s) and the sample information are provided by the client.

4 Content

1 COVER PAGE	1
2 VERSION	2
3 TEST SUMMARY	3
4 CONTENT	4
5 TEST REQUIREMENT	5
5.1 TEST SETUP.....	5
5.1.1 For Conducted test setup.....	5
5.1.2 For Radiated Emissions test setup.....	5
5.1.3 For Conducted Emissions test setup.....	6
5.2 TEST ENVIRONMENT.....	6
5.3 TEST CONDITION.....	6
6 GENERAL INFORMATION	7
6.1 CLIENT INFORMATION.....	7
6.2 GENERAL DESCRIPTION OF EUT.....	7
6.3 PRODUCT SPECIFICATION SUBJECTIVE TO THIS STANDARD.....	7
6.4 DESCRIPTION OF SUPPORT UNITS.....	8
6.5 TEST LOCATION.....	8
6.6 TEST FACILITY.....	8
6.7 DEVIATION FROM STANDARDS.....	9
6.8 ABNORMALITIES FROM STANDARD CONDITIONS.....	9
6.9 OTHER INFORMATION REQUESTED BY THE CUSTOMER.....	9
6.10 MEASUREMENT UNCERTAINTY (95% CONFIDENCE LEVELS, K=2).....	9
7 EQUIPMENT LIST	10
8 RADIO TECHNICAL REQUIREMENTS SPECIFICATION	12
Appendix A) Conducted Peak Output Power.....	13
Appendix B) 6dB Occupied Bandwidth.....	18
Appendix C) Band-edge for RF Conducted Emissions.....	23
Appendix D) RF Conducted Spurious Emissions.....	26
Appendix E) Power Spectral Density.....	35
Appendix F) Antenna Requirement.....	40
Appendix G) AC Power Line Conducted Emission.....	41
Appendix H) Restricted bands around fundamental frequency (Radiated).....	44
Appendix I) Radiated Spurious Emissions.....	46
PHOTOGRAPHS OF TEST SETUP	55
PHOTOGRAPHS OF EUT CONSTRUCTIONAL DETAILS	57

5 Test Requirement

5.1 Test setup

5.1.1 For Conducted test setup

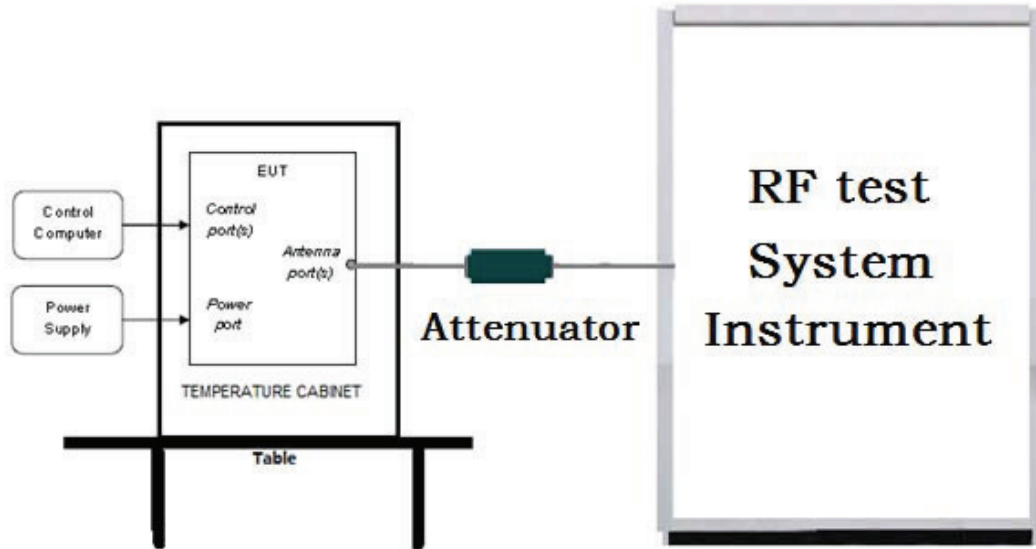

5.1.2 For Radiated Emissions test setup

Radiated Emissions setup:

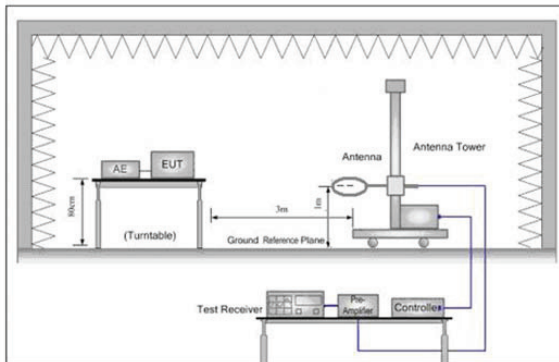

Figure 1. Below 30MHz

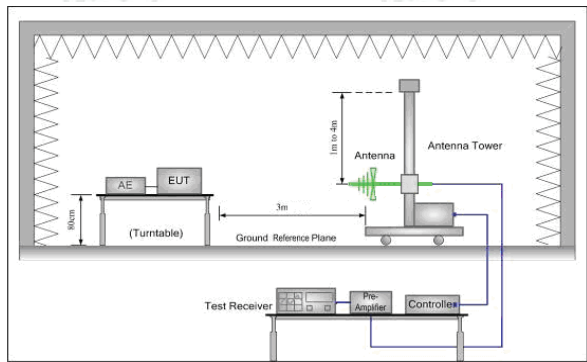

Figure 2. 30MHz to 1GHz

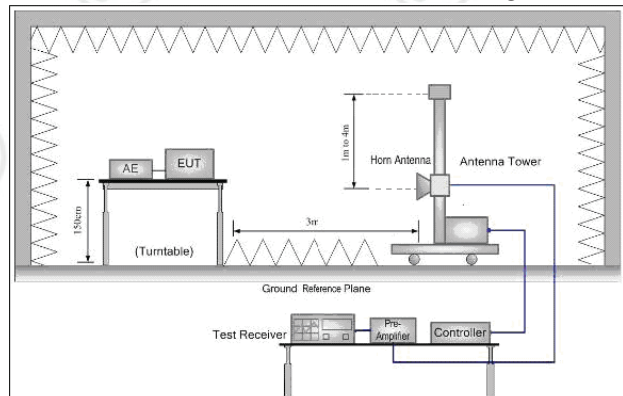
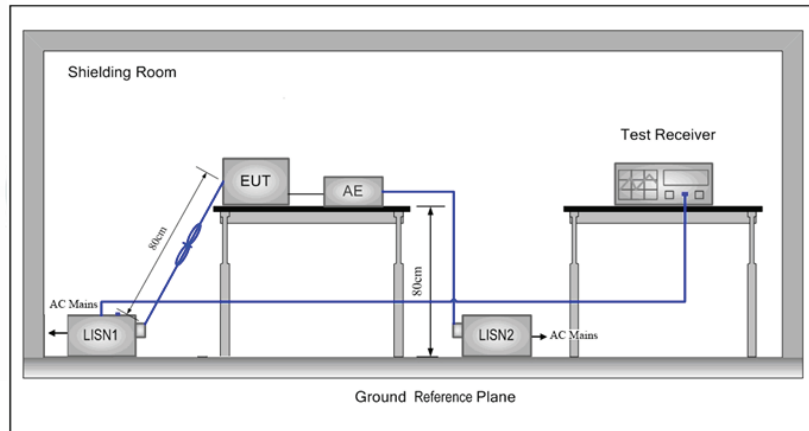

Figure 3. Above 1GHz

5.1.3 For Conducted Emissions test setup

Conducted Emissions setup



5.2 Test Environment

Operating Environment:	
Temperature:	21°C
Humidity:	58 % RH
Atmospheric Pressure:	1010mbar

5.3 Test Condition

Test channel:

Test Mode	Tx/Rx	RF Channel		
		Low(L)	Middle(M)	High(H)
802.11b/g/n(HT20)	2412MHz ~2462 MHz	Channel 1	Channel 6	Channel11
		2412MHz	2437MHz	2462MHz
802.11n(HT40)	2422MHz ~2452 MHz	Channel 1	Channel 4	Channel7
		2422MHz	2437MHz	2452MHz
Transmitting mode:	The EUT transmitted the continuous modulation test signal at the specific channel(s). dutycycle>98%			

Test mode:

Pre-scan under all rate at lowest channel 1

Mode	802.11b				X				
Data Rate	1Mbps	2Mbps	5.5Mbps	11Mbps					
EIRP(dBm)	17.15	17.44	17.56	17.67					
Mode	802.11g								
Data Rate	6Mbps	9Mbps	12Mbps	18Mbps	24Mbps	36Mbps	48Mbps	54Mbps	
EIRP(dBm)	15.25	15.11	15.09	14.89	14.86	14.72	14.69	14.70	
Mode	802.11n (HT20)								
Data Rate	6.5Mbps	13Mbps	19.5Mbps	26Mbps	39Mbps	52Mbps	58.5Mbps	65Mbps	
EIRP(dBm)	13.61	13.55	13.50	13.46	13.32	13.30	13.22	13.01	
Mode	802.11n (HT40)								
Data Rate	13.5Mbps	27Mbps	40.5Mbps	54Mbps	81Mbps	108Mbps	121.5Mbps	135Mbps	
EIRP(dBm)	13.96	13.90	13.82	13.78	13.77	13.62	13.54	13.53	

Through Pre-scan, 11Mbps of rate is the worst case of 802.11b; 6Mbps of rate is the worst case of 802.11g; 6.5Mbps of rate is the worst case of 802.11n(HT20); 13.5Mbps of rate is the worst case of 802.11n(HT40).

Remark :85%-115% input power have been adjusted , worse case is reported , X,Y,Z axile polarity all have been tested for radiated emission, only worse case is reported

6 General Information

6.1 Client Information

Applicant:	Hui Zhou Gaoshengda Technology Co., LTD
Address of Applicant:	NO.75 Zhongkai Development Area, Huizhou, Guangdong
Manufacturer:	Hui Zhou Gaoshengda Technology Co., LTD
Address of Manufacturer:	NO.75 Zhongkai Development Area, Huizhou, Guangdong

6.2 General Description of EUT

Product Name:	WIFI Module
Model No.(EUT):	W7HM1200
Trade Mark:	GSD
EUT Supports Radios application:	Wlan 2.4GHz 802.11b/g/n(HT20&HT40)
Power Supply:	Supply by 5V from USB
Sample Received Date:	Sep. 08, 2015
Sample tested Date:	Sep. 08, 2015 to Oct. 09, 2015

6.3 Product Specification subjective to this standard

Operation Frequency:	IEEE 802.11b/g/n(HT20): 2412MHz to 2462MHz IEEE 802.11n(HT40): 2422MHz to 2452MHz
Channel Numbers:	IEEE 802.11b/g, IEEE 802.11n HT20: 11 Channels IEEE 802.11n HT40: 7 Channels
Channel Separation:	5MHz
Type of Modulation:	IEEE for 802.11b: DSSS(CCK,DQPSK,DBPSK) IEEE for 802.11g: OFDM(64QAM, 16QAM, QPSK, BPSK) IEEE for 802.11n(HT20 and HT40): OFDM (64QAM, 16QAM, QPSK, BPSK)
Sample Type:	Fixed production
Antenna Type and Gain:	Type: Integral antenna Gain: 3.5dBi
Test Voltage:	PC: AC 120V/60Hz; EUT: 5Vfrom PC USB

Operation Frequency each of channel(802.11b/g/n HT20)

Channel	Frequency	Channel	Frequency	Channel	Frequency	Channel	Frequency
1	2412MHz	4	2427MHz	7	2442MHz	10	2457MHz
2	2417MHz	5	2432MHz	8	2447MHz	11	2462MHz
3	2422MHz	6	2437MHz	9	2452MHz		

Operation Frequency each of channel(802.11n HT40)

Channel	Frequency	Channel	Frequency	Channel	Frequency
1	2422MHz	4	2437MHz	7	2452MHz
2	2427MHz	5	2442MHz		
3	2432MHz	6	2447MHz		

6.4 Description of Support Units

The EUT has been tested with associated equipment below.

Description	Manufacturer	Model No.	Certification	Supplied by
USB cable	N/A	N/A	FCC	Client
Notebook	lenovo	B41	FCC	CTI

6.5 Test Location

All tests were performed at:

Centre Testing International Group Co., Ltd.

Hongwei Industrial Zone, Bao'an 70 District, Shenzhen, Guangdong, China518101

Telephone: +86 (0) 755 3368 3668 Fax:+86 (0) 755 3368 3385

No tests were sub-contracted.

6.6 Test Facility

The test facility is recognized, certified, or accredited by the following organizations:

CNAS-Lab Code: L1910

Centre Testing International Group Co., Ltd. has been assessed and proved to be in compliance with CNAS-CL01 Accreditation Criteria for Testing and Calibration Laboratories (identical to ISO/IEC 17025: 2005 General Requirements) for the Competence of Testing and Calibration Laboratories..

A2LA-Lab Cert. No. 3061.01

Centre Testing International Group Co., Ltd. EMC Laboratory has been accredited by A2LA for technical competence in the field of electrical testing, and proved to be in compliance with ISO/IEC 17025: 2005 General Requirements for the Competence of Testing and Calibration Laboratories and any additional program requirements in the identified field of testing.

FCC-Registration No.: 565659

Centre Testing International Group Co., Ltd. EMC Laboratory has been registered and fully described in a report filed with the FCC (Federal Communications Commission). The acceptance letter from the FCC is maintained in our files. Registration 565659.

IC-Registration No.: 7408A

The 3m Alternate Test Site of Centre Testing International Group Co., Ltd. has been registered by Certification and Engineering Bureau of Industry Canada for the performance of radiated measurements with Registration No. 7408A .

IC-Registration No.: 7408B

The 10m Alternate Test Site of Centre Testing International Group Co., Ltd. has been registered by Certification and Engineering Bureau of Industry Canada for the performance of radiated measurements with Registration No. 7408B.

NEMKO-Aut. No.: ELA503

Centre Testing International Group Co., Ltd. has been assessed the quality assurance system, the testing facilities, qualifications and testing practices of the relevant parts of the organization. The quality

assurance system of the Laboratory has been validated against ISO/IEC 17025 or equivalent. The laboratory also fulfils the conditions described in Nemko Document NLA-10.

VCCI

The Radiation 3 & 10 meters site of Centre Testing International Group Co., Ltd. has been registered in accordance with the Regulations for Voluntary Control Measures with Registration No.: R-4096.

Main Ports Conducted Interference Measurement of Centre Testing International Group Co., Ltd. has been registered in accordance with the Regulations for Voluntary Control Measures with Registration No.: C-4563.

Telecommunication Ports Conducted Disturbance Measurement of Centre Testing International Group Co., Ltd. has been registered in accordance with the Regulations for Voluntary Control Measures with Registration No.: T-2146.

The Radiation 3 meters site of Centre Testing International Group Co., Ltd. has been registered in accordance with the Regulations for Voluntary Control Measures with Registration No.: G-758

6.7 Deviation from Standards

None.

6.8 Abnormalities from Standard Conditions

None.

6.9 Other Information Requested by the Customer

None.

6.10 Measurement Uncertainty (95% confidence levels, k=2)

No.	Item	Measurement Uncertainty
1	Radio Frequency	7.9×10^{-8}
2	RF power, conducted	0.31dB (30MHz-1GHz)
		0.57dB (1GHz-18GHz)
3	Radiated Spurious emission test	4.5dB (30MHz-1GHz)
		4.8dB (1GHz-12.75GHz)
4	Conduction emission	3.6dB (9kHz to 150kHz)
		3.2dB (150kHz to 30MHz)
5	Temperature test	0.64°C
6	Humidity test	2.8%
7	DC power voltages	0.025%

7 Equipment List

RF test system					
Equipment	Manufacturer	Mode No.	Serial Number	Cal. Date (mm-dd-yyyy)	Cal. Due date (mm-dd-yyyy)
Signal Generator	Keysight	E8257D	MY53401106	04-14-2015	04-13-2016
Communication test set test set	Agilent	N4010A	MY47230124	04-02-2015	04-01-2016
Spectrum Analyzer	Keysight	N9010A	MY54510339	04-01-2015	03-31-2016
Attenuator	HuaXiang	SHX370	15040701	04-01-2015	03-31-2016
Signal Generator	Keysight	N5182B	MY53051549	03-31-2015	03-30-2016
High-pass filter(3-18GHz)	Sinoscite	FL3CX03WG18 NM12-0398-002	---	01-13-2015	01-12-2016
High-pass filter(5-18GHz)	MICRO-TRONICS	SPA-F-63029-4	---	01-13-2015	01-12-2016
band rejection filter (GSM900)	Sinoscite	FL5CX01CA09C L12-0395-001	---	01-13-2015	01-12-2016
band rejection filter (GSM850)	Sinoscite	FL5CX01CA08C L12-0393-001	---	01-13-2015	01-12-2016
band rejection filter (GSM1800)	Sinoscite	FL5CX02CA04C L12-0396-002	---	01-13-2015	01-12-2016
band rejection filter (GSM1900)	Sinoscite	FL5CX02CA03C L12-0394-001	---	01-13-2015	01-12-2016
DC Power	Keysight	E3642A	MY54436035	03-31-2015	03-30-2016
PC-1	Lenovo	R4960d	---	04-01-2015	03-31-2016
BT&WI-FI Automatic control	R&S	OSPB157	101374	04-01-2015	03-31-2016
RF control unit	JS Tonscend	JS0806-2	2015860006	04-01-2015	03-31-2016
BT&WI-FI Automatic test software	JS Tonscend	JSTS1120-2	---	04-01-2015	03-31-2016

3M Semi/full-anechoic Chamber					
Equipment	Manufacturer	Mode No.	Serial Number	Cal. date (mm-dd-yyyy)	Cal. Due date (mm-dd-yyyy)
3M Chamber	TDK	SAC-3	---	06-02-2013	06-01-2016
TRILOG Broadband Antenna	schwarzbeck	VULB9163	9163-617	07-31-2015	07-29-2016
Microwave Preamplifier	Agilent	8449B	3008A02425	02-05-2015	02-04-2016
Horn Antenna	ETS-LINDGREN	3117	00057410	06-30-2015	06-28-2018
Loop Antenna	ETS	6502	00071730	07-30-2015	07-28-2017
Spectrum Analyzer	R&S	FSP40	100416	06-30-2015	06-28-2016
Receiver	R&S	ESCI	100435	06-30-2015	06-28-2016
Multi device Controller	matur	NCD/070/10711112	---	01-13-2015	01-12-2016
LISN	schwarzbeck	NNBM8125	81251547	06-30-2015	06-28-2016
LISN	schwarzbeck	NNBM8125	81251548	06-30-2015	06-28-2016
Signal Generator	Agilent	E4438C	MY45095744	04-19-2015	04-18-2016
Signal Generator	Keysight	E8257D	MY53401106	04-14-2015	04-13-2016
Temperature/ Humidity Indicator	TAYLOR	1451	5190	07-09-2015	07-08-2016
Communication test set	Agilent	E5515C	GB47050533	01-13-2015	01-12-2016
Cable line	Fulai(7M)	SF106	5219/6A	01-13-2015	01-12-2016
Cable line	Fulai(6M)	SF106	5220/6A	01-13-2015	01-12-2016
Cable line	Fulai(3M)	SF106	5216/6A	01-13-2015	01-12-2016
Cable line	Fulai(3M)	SF106	5217/6A	01-13-2015	01-12-2016
Communication test set	R&S	CMW500	152394	04-19-2015	04-18-2016
High-pass filter(3-18GHz)	Sinoscite	FL3CX03WG18NM 12-0398-002	---	01-13-2015	01-12-2016
High-pass filter(5-18GHz)	MICRO-TRONICS	SPA-F-63029-4	---	01-13-2015	01-12-2016
band rejection filter	Sinoscite	FL5CX01CA09CL1 2-0395-001	---	01-13-2015	01-12-2016
band rejection filter	Sinoscite	FL5CX01CA08CL1 2-0393-001	---	01-13-2015	01-12-2016
band rejection filter	Sinoscite	FL5CX02CA04CL1 2-0396-002	---	01-13-2015	01-12-2016
band rejection filter	Sinoscite	FL5CX02CA03CL1 2-0394-001	---	01-13-2015	01-12-2016

8 Radio Technical Requirements Specification

Reference documents for testing:

No.	Identity	Document Title
1	FCC Part15C (2014)	Subpart C-Intentional Radiators
2	ANSI C63.10-2013	American National Standard for Testing Unlicensed Wireless Devices

Test Results List:

Test Requirement	Test method	Test item	Verdict	Note
Part15C Section 15.247 (b)(3)	ANSI C63.10	Conducted Peak Output Power	PASS	Appendix A)
Part15C Section 15.247 (a)(2)	ANSI C63.10	6dB Occupied Bandwidth	PASS	Appendix B)
Part15C Section 15.247(d)	ANSI C63.10	Band-edge for RF Conducted Emissions	PASS	Appendix C)
Part15C Section 15.247(d)	ANSI C63.10	RF Conducted Spurious Emissions	PASS	Appendix D)
Part15C Section 15.247 (e)	ANSI C63.10	Power Spectral Density	PASS	Appendix E)
Part15C Section 15.203/15.247 (c)	ANSI C63.10	Antenna Requirement	PASS	Appendix F)
Part15C Section 15.207	ANSI C63.10	AC Power Line Conducted Emission	PASS	Appendix G)
Part15C Section 15.205/15.209	ANSI C63.10	Restricted bands around fundamental frequency (Radiated Emission)	PASS	Appendix H)
Part15C Section 15.205/15.209	ANSI C63.10	Radiated Spurious Emissions	PASS	Appendix I)

**Appendix A) Conducted Peak Output Power
Result Table**

Mode	Channel	Conducted Peak Output Power [dBm]	Verdict
11B	LCH	16.42	PASS
11B	MCH	17.39	PASS
11B	HCH	17.67	PASS
11G	LCH	15.25	PASS
11G	MCH	14.99	PASS
11G	HCH	15.08	PASS
11N20SISO	LCH	13.24	PASS
11N20SISO	MCH	13.61	PASS
11N20SISO	HCH	12.51	PASS
11N40SISO	LCH	12.25	PASS
11N40SISO	MCH	12.26	PASS
11N40SISO	HCH	13.96	PASS

Remark: peak detector.

Test Graph

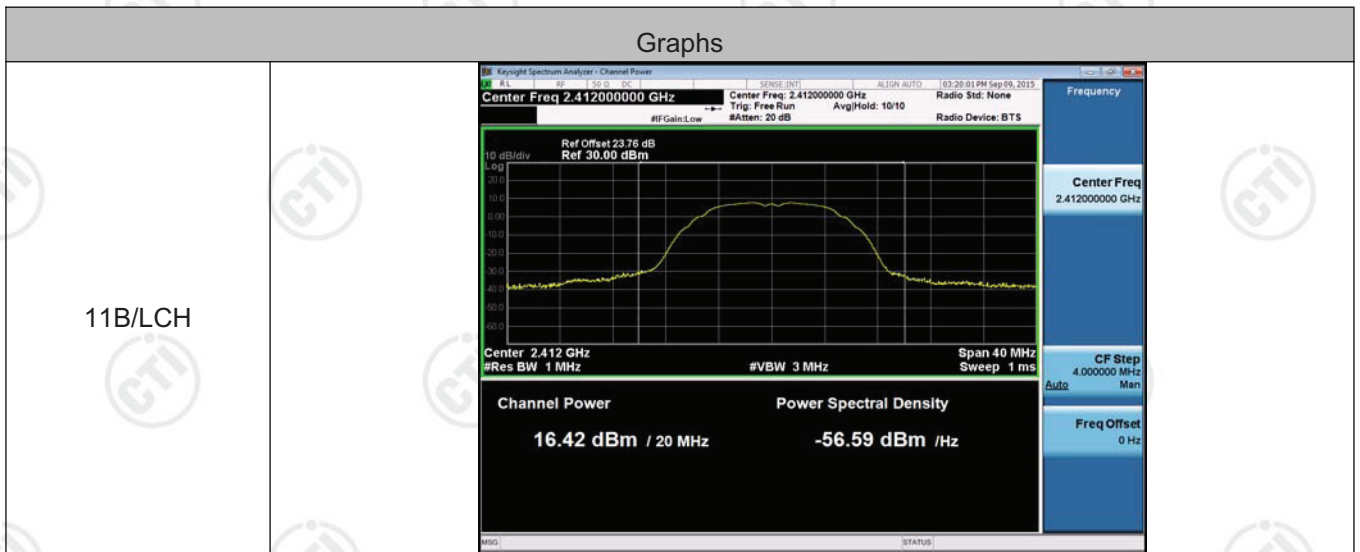

<p>11B/MCH</p>	 <p>Keysight Spectrum Analyzer - Channel Power</p> <p>Center Freq: 2.437000000 GHz</p> <p>Ref Offset: 23.76 dB Ref: 30.00 dBm</p> <p>Channel Power: 17.39 dBm / 20 MHz</p> <p>Power Spectral Density: -55.62 dBm / Hz</p> <p>Center: 2.437 GHz #Res BW: 1 MHz #VBW: 3 MHz Span: 40 MHz Sweep: 1 ms</p>
<p>11B/HCH</p>	 <p>Keysight Spectrum Analyzer - Channel Power</p> <p>Center Freq: 2.462000000 GHz</p> <p>Ref Offset: 23.76 dB Ref: 30.00 dBm</p> <p>Channel Power: 17.67 dBm / 20 MHz</p> <p>Power Spectral Density: -55.34 dBm / Hz</p> <p>Center: 2.462 GHz #Res BW: 1 MHz #VBW: 3 MHz Span: 40 MHz Sweep: 1 ms</p>
<p>11G/LCH</p>	 <p>Keysight Spectrum Analyzer - Channel Power</p> <p>Center Freq: 2.412000000 GHz</p> <p>Ref Offset: 21.86 dB Ref: 30.00 dBm</p> <p>Channel Power: 15.25 dBm / 20 MHz</p> <p>Power Spectral Density: -57.76 dBm / Hz</p> <p>Center: 2.412 GHz #Res BW: 1 MHz #VBW: 3 MHz Span: 40 MHz Sweep: 1 ms</p>

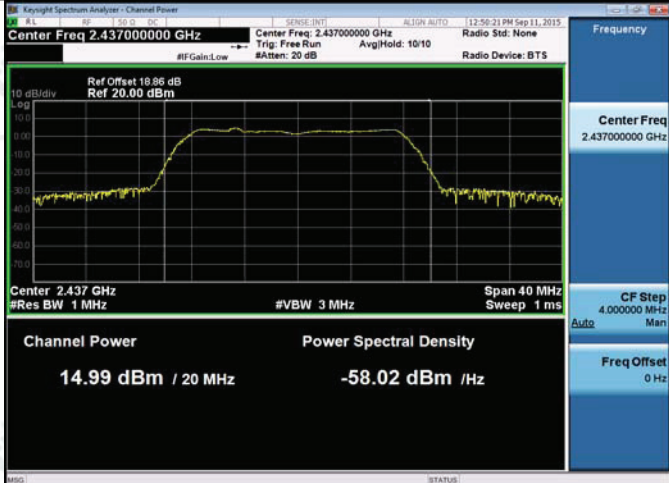
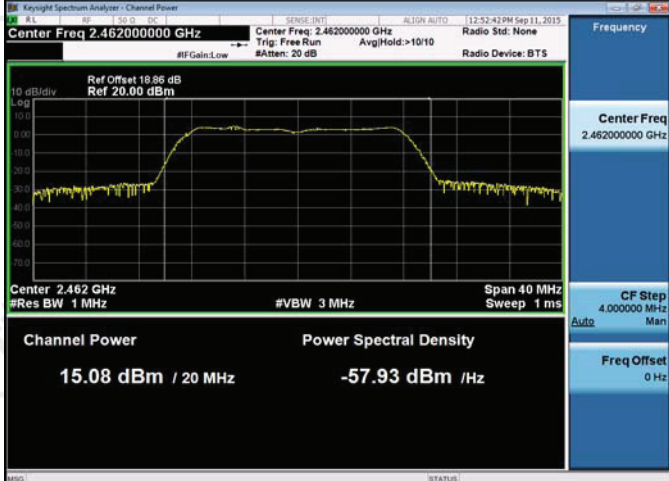
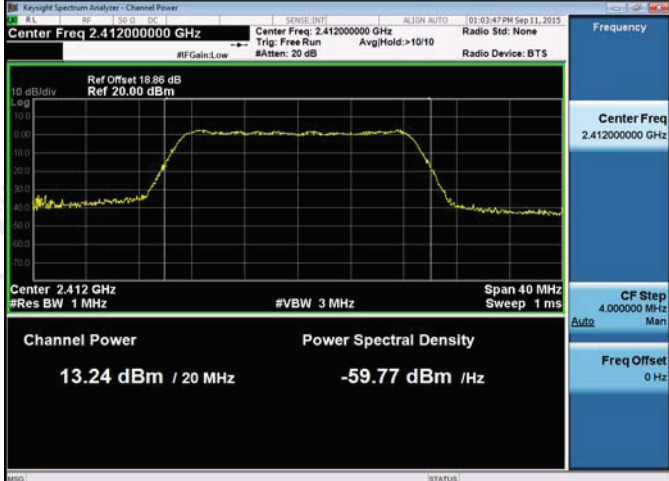
<p>11G/MCH</p>	 <p>Keysight Spectrum Analyzer - Channel Power</p> <p>Center Freq: 2.437000000 GHz</p> <p>Channel Power: 14.99 dBm / 20 MHz</p> <p>Power Spectral Density: -58.02 dBm /Hz</p>
<p>11G/HCH</p>	 <p>Keysight Spectrum Analyzer - Channel Power</p> <p>Center Freq: 2.462000000 GHz</p> <p>Channel Power: 15.08 dBm / 20 MHz</p> <p>Power Spectral Density: -57.93 dBm /Hz</p>
<p>11N20SISO/LCH</p>	 <p>Keysight Spectrum Analyzer - Channel Power</p> <p>Center Freq: 2.412000000 GHz</p> <p>Channel Power: 13.24 dBm / 20 MHz</p> <p>Power Spectral Density: -59.77 dBm /Hz</p>