



CFR 47 FCC PART 15 SUBPART C

TEST REPORT

For

WIFI+BT Module

MODEL NUMBER: WT54M2000

FCC ID: 2AC23-WT54

REPORT NUMBER: 4788989204-3

ISSUE DATE: June 17, 2019

Prepared for

**Hui Zhou Gaoshengda Technology Co.,LTD
NO.75 Zhongkai Development Area Huizhou, Guangdong China**

Prepared by

**UL Verification Services (Guangzhou) Co., Ltd, Song Shan Lake Branch
Building 10, Innovation Technology Park, No. 1, Li Bin Road, Song Shan Lake
Hi-Tech Development Zone Dongguan, People's Republic of China
Tel: +86 769 22038881
Fax: +86 769 33244054
Website: www.ul.com**



Revision History

<u>Rev.</u>	<u>Issue Date</u>	<u>Revisions</u>	<u>Revised By</u>
V0	06/17/2019	Initial Issue	



Summary of Test Results			
Clause	Test Items	FCC Rules	Test Results
1	6dB Bandwidth and 99% Occupied Bandwidth	FCC Part 15.247 (a) (2)	Pass
2	Peak Conducted Output Power	FCC Part 15.247 (b) (3)	Pass
3	Power Spectral Density	FCC Part 15.247 (e)	Pass
4	Conducted Bandedge and Spurious Emission	FCC Part 15.247 (d)	Pass
5	Radiated Bandedge and Spurious Emission	FCC Part 15.247 (d) FCC Part 15.209 FCC Part 15.205	Pass
6	Conducted Emission Test For AC Power Port	FCC Part 15.207	Pass
7	Antenna Requirement	FCC Part 15.203	Pass



TABLE OF CONTENTS

1. ATTESTATION OF TEST RESULTS	6
2. TEST METHODOLOGY	7
3. FACILITIES AND ACCREDITATION	7
4. CALIBRATION AND UNCERTAINTY	8
4.1. <i>MEASURING INSTRUMENT CALIBRATION</i>	<i>8</i>
4.2. <i>CMEASUREMENT UNCERTAINTY</i>	<i>8</i>
5. EQUIPMENT UNDER TEST	9
5.1. <i>DESCRIPTION OF EUT</i>	<i>9</i>
5.2. <i>MAXIMUM OUTPUT POWER.....</i>	<i>9</i>
5.3. <i>CHANNEL LIST</i>	<i>10</i>
5.4. <i>TEST CHANNEL CONFIGURATION.....</i>	<i>10</i>
5.5. <i>THE WORSE CASE POWER SETTING PARAMETER.....</i>	<i>11</i>
5.6. <i>THE WORSE CASE CONFIGURATIONS</i>	<i>11</i>
5.7. <i>DESCRIPTION OF AVAILABLE ANTENNAS</i>	<i>12</i>
5.8. <i>DESCRIPTION OF TEST SETUP.....</i>	<i>13</i>
6. MEASURING INSTRUMENT AND SOFTWARE USED	14
7. MEASUREMENT METHODS	15
8. ANTENNA PORT TEST RESULTS	16
8.1. <i>ON TIME AND DUTY CYCLE.....</i>	<i>16</i>
8.2. <i>6 dB DTS BANDWIDTH AND 99% OCCUPIED BANDWIDTH</i>	<i>20</i>
8.2.1. <i>802.11b SISO MODE.....</i>	<i>21</i>
8.2.2. <i>802.11g SISO MODE.....</i>	<i>25</i>
8.2.3. <i>802.11n HT20 MIMO MODE.....</i>	<i>29</i>
8.2.4. <i>802.11n HT40 MIMO MODE.....</i>	<i>33</i>
8.3. <i>PEAK CONDUCTED OUTPUT POWER.....</i>	<i>37</i>
8.3.1. <i>802.11b SISO MODE.....</i>	<i>38</i>
8.3.2. <i>802.11g SISO MODE.....</i>	<i>39</i>
8.3.3. <i>802.11n HT20 MIMO MODE.....</i>	<i>40</i>
8.3.4. <i>802.11n HT40 MIMO MODE.....</i>	<i>41</i>
8.4. <i>POWER SPECTRAL DENSITY</i>	<i>42</i>
8.4.1. <i>802.11b SISO MODE.....</i>	<i>43</i>
8.4.1. <i>802.11g SISO MODE.....</i>	<i>46</i>
8.4.2. <i>802.11n HT20 MIMO MODE.....</i>	<i>49</i>
8.4.3. <i>802.11n HT40 MIMO MODE.....</i>	<i>53</i>
8.5. <i>CONDUCTED BANDEDGE AND SPURIOUS EMISSIONS.....</i>	<i>57</i>



8.5.1.	802.11b SISO MODE.....	59
8.5.2.	802.11g SISO MODE.....	65
8.5.3.	802.11n HT20 MIMO MODE.....	71
8.5.4.	802.11n HT40 MIMO MODE.....	83
9.	RADIATED TEST RESULTS.....	95
9.1.	<i>RESTRICTED BANDEDGE.....</i>	<i>101</i>
9.1.1.	802.11b SISO MODE.....	101
9.1.2.	802.11g SISO MODE.....	107
9.1.3.	802.11n HT20 MIMO MODE.....	115
9.1.4.	802.11n HT40 MIMO MODE.....	123
9.2.	<i>SPURIOUS EMISSIONS (3~18GHz).....</i>	<i>131</i>
9.2.1.	802.11b SISO MODE.....	131
9.2.2.	802.11g SISO MODE.....	137
9.2.3.	802.11n HT20 MIMO MODE.....	143
9.2.4.	802.11n HT40 MIMO MODE.....	149
9.3.	<i>SPURIOUS EMISSIONS (1~3GHz).....</i>	<i>155</i>
9.3.1.	802.11b SISO MODE.....	155
9.3.2.	802.11g SISO MODE.....	161
9.3.3.	802.11n HT20 MIMO MODE.....	167
9.3.4.	802.11n HT40 MIMO MODE.....	173
9.4.	<i>WORST-CASE CO-LOCATION.....</i>	<i>179</i>
9.4.1.	BT GFSK AND 802.11n HT20 MIMO MODE	179
9.5.	<i>SPURIOUS EMISSIONS (18~26GHz).....</i>	<i>187</i>
9.5.1.	802.11n HT20 MIMO MODE.....	187
9.6.	<i>SPURIOUS EMISSIONS (0.03 ~ 1 GHz).....</i>	<i>189</i>
9.6.1.	802. 11n HT20 MIMO MODE.....	189
9.7.	<i>SPURIOUS EMISSIONS BELOW 30M.....</i>	<i>191</i>
9.7.1.	802. 11n HT20 MIMO MODE.....	191
10.	AC POWER LINE CONDUCTED EMISSIONS	194
10.1.	802. 11n HT20 MIMO MODE	195
11.	ANTENNA REQUIREMENTS	197



1. ATTESTATION OF TEST RESULTS

Applicant Information

Company Name: Hui Zhou Gaoshengda Technology Co.,LTD
Address: NO.75 Zhongkai Development Area Huizhou, Guangdong China

Manufacturer Information

Company Name: Hui Zhou Gaoshengda Technology Co.,LTD
Address: NO.75 Zhongkai Development Area Huizhou, Guangdong China

EUT Description

EUT Name: WIFI+BT Module
Model: WT54M2000
Sample Status: Normal
Brand Name: GSD
Sample Received Date: April 28, 2019
Date of Tested: April 29 ~ June 17, 2019

APPLICABLE STANDARDS	
STANDARD	TEST RESULTS
CFR 47 FCC PART 15 SUBPART C	PASS

Prepared By:

Kebo Zhang
Engineer Project Associate

Checked By:

Shawn Wen
Laboratory Leader

Approved By:

Stephen Guo
Laboratory Manager



2. TEST METHODOLOGY

The tests documented in this report were performed in accordance with KDB 558074 D01 DTS Meas Guidance v05r02, KDB 414788 D01 Radiated Test Site v01r01, KDB 662911 D01 Multiple Transmitter Output v02r01, CFR 47 FCC Part 2, CFR 47 FCC Part 15, ANSI C63.10-2013, ISED RSS-247 Issue 2 and ISED RSS-GEN Issue 5.

3. FACILITIES AND ACCREDITATION

Accreditation Certificate	<p>A2LA (Certificate No.: 4102.01) UL Verification Services (Guangzhou) Co., Ltd. Song Shan Lake Branch. has been assessed and proved to be in compliance with A2LA.</p> <p>FCC (FCC Designation No.: CN1187) UL Verification Services (Guangzhou) Co., Ltd. Song Shan Lake Branch. Has been recognized to perform compliance testing on equipment subject to the Commission's Declaration of Conformity (DoC) and Certification rules</p> <p>ISED(Company No.: 21320) UL Verification Services (Guangzhou) Co., Ltd. Song Shan Lake Branch. has been registered and fully described in a report filed with ISED. The Company Number is 21320.</p> <p>VCCI (Registration No.: G-20019, R-20004, C-20012 and T-20011) UL Verification Services (Guangzhou) Co., Ltd. Song Shan Lake Branch. has been assessed and proved to be in compliance with VCCI, the Membership No. is 3793. Facility Name: Chamber D, the VCCI registration No. is G-20019 and R-20004 Shielding Room B , the VCCI registration No. is C-20012 and T-20011</p>
---------------------------	---

Note:

1. All tests measurement facilities use to collect the measurement data are located at Building 10, Innovation Technology Park, Song Shan Lake Hi tech Development Zone, Dongguan, 523808, China
2. The test anechoic chamber in UL Verification Services (Guangzhou) Co., Ltd. Song Shan Lake Branch had been calibrated and compared to the open field sites and the test anechoic chamber is shown to be equivalent to or worst case from the open field site.
3. For below 30MHz, lab had performed measurements at test anechoic chamber and comparing to measurements obtained on an open field site. And these measurements below 30MHz had been correlated to measurements performed on an OFS.



4. CALIBRATION AND UNCERTAINTY

4.1. MEASURING INSTRUMENT CALIBRATION

The measuring equipment utilized to perform the tests documented in this report has been calibrated in accordance with the manufacturer's recommendations, and is traceable to recognize national standards.

4.2. CMEASUREMENT UNCERTAINTY

Where relevant, the following measurement uncertainty levels have been estimated for tests performed on the apparatus:

Test Item	Uncertainty
Conduction emission	3.62dB
Radiation Emission test(include Fundamental emission) (9KHz-30MHz)	2.2dB
Radiation Emission test(include Fundamental emission) (30MHz-1GHz)	4.00dB
Radiation Emission test (1GHz to 26GHz)(include Fundamental emission)	5.78dB (1GHz-18Gz)
	5.23dB (18GHz-26Gz)
Note: This uncertainty represents an expanded uncertainty expressed at approximately the 95% confidence level using a coverage factor of k=2.	



5. EQUIPMENT UNDER TEST

5.1. DESCRIPTION OF EUT

EUT Name	WIFI+BT Module
Model	WT54M2000
Radio Technology	IEEE802.11b/g/n HT20/HT40
Operation frequency	IEEE 802.11b: 2412MHz—2462MHz IEEE 802.11g: 2412MHz—2462MHz IEEE 802.11n HT20: 2412MHz—2462MHz IEEE 802.11n HT40: 2422MHz—2452MHz
Modulation	IEEE 802.11b: DSSS(CCK) IEEE 802.11g: OFDM(64QAM, 16QAM, QPSK, BPSK) IEEE 802.11n HT20: OFDM (64QAM, 16QAM, QPSK,BPSK) IEEE 802.11n HT40: OFDM (64QAM, 16QAM, QPSK,BPSK)
Rated Input	DC 3.3V

5.2. MAXIMUM OUTPUT POWER

Number of Transmit Chains (NTX)	IEE Std. 802.11	Frequency (MHz)	Channel Number	Max PK Conducted Power (dBm)
2	IEEE 802.11b	2412-2462	1-11[11]	18.72
2	IEEE 802.11g	2412-2462	1-11[11]	20.99
2	IEEE 802.11nHT20	2412-2462	1-11[11]	22.79
2	IEEE 802.11nHT40	2422-2452	3-9[7]	22.03



5.3. CHANNEL LIST

Channel List for 802.11b/g/n (20 MHz)							
Channel	Frequency (MHz)	Channel	Frequency (MHz)	Channel	Frequency (MHz)	Channel	Frequency (MHz)
1	2412	4	2427	7	2442	10	2457
2	2417	5	2432	8	2447	11	2462
3	2422	6	2437	9	2452	/	/

Channel List for 802.11n (40 MHz)							
Channel	Frequency (MHz)	Channel	Frequency (MHz)	Channel	Frequency (MHz)	Channel	Frequency (MHz)
3	2422	5	2432	7	2442	9	2452
4	2427	6	2437	8	2447	/	/

5.4. TEST CHANNEL CONFIGURATION

Test Mode	Test Channel	Frequency
WiFi TX(802.11b)	CH 1, CH 6, CH 11	2412MHz, 2437MHz, 2462MHz
WiFi TX(802.11g)	CH 1, CH 6, CH 11	2412MHz, 2437MHz, 2462MHz
WiFi TX(802.11n HT20)	CH 1, CH 6, CH 11	2412MHz, 2437MHz, 2462MHz
WiFi TX(802.11n HT40)	CH 3, CH 6, CH 9	2422MHz, 2437MHz, 2452MHz



5.5. THE WORSE CASE POWER SETTING PARAMETER

The Worse Case Power Setting Parameter under 2400 ~ 2483.5MHz Band							
Test Software		QATool_Dbg					
Modulation Mode	Transmit Antenna Number	Test Channel					
		NCB: 20MHz			NCB: 40MHz		
		CH 1	CH 6	CH 11	CH 3	CH 6	CH 9
802.11b	2	default	default	default	N/A		
802.11g	2	default	default	default			
802.11n HT20	2	default	default	default			
802.11n HT40	2	N/A			18	18	18

5.6. THE WORSE CASE CONFIGURATIONS

For SISO modes, there are two transmission antennas. The antenna used in any given time can be either ANTENNA 0 or ANTENNA 1. All antenna ports have the same power; output power measurement for SISO modes on both antennas are reported.

For 2TX MIMO modes, ANTENNA 0 and ANTENNA 1, used at the same time.

Worst-case data rates as provided by the client were:

802.11b mode: 1 Mbps

802.11g mode: 6 Mbps

802.11n HT20 mode: MCS0

802.11n HT40 mode: MCS0

Note: Only 802.11n HT20 and 802.11n HT40 support MIMO mode, for 802.11b and 802.11g , all antennas had been test ,but only the worst data for Antenna 1 was recorded; for 802.11n HT20 and 802.11n HT40, all antennas had the same power in MIMO mode and SISO mode, so only the worst data for MIMO mode was recorded.



5.7. DESCRIPTION OF AVAILABLE ANTENNAS

Antenna	Frequency (MHz)	Antenna Type	Antenna Gain (dBi)
0	2412-2462	IPEX Connector	4.74
1	2412-2462	IPEX Connector	4.74

Note: Directional gain= $G_{ANT} + 10 \log(N_{ANT})$ dBi=7.75dBi

G_{ANT} : Average of the Antenna Gain

N_{ANT} : Antenna numbers

Test Mode	Transmit and Receive Mode	Description
IEEE 802.11b	<input checked="" type="checkbox"/> 2TX, 2RX	Antenna 0 and Antenna 1 can be used as transmitting/receiving antenna.
IEEE 802.11g	<input checked="" type="checkbox"/> 2TX, 2RX	Antenna 0 and Antenna 1 can be used as transmitting/receiving antenna
IEEE 802.11n HT20	<input checked="" type="checkbox"/> 2TX, 2RX	Antenna 0 and Antenna 1 can be used as transmitting/receiving antenna
IEEE 802.11n HT40	<input checked="" type="checkbox"/> 2TX, 2RX	Antenna 0 and Antenna 1 can be used as transmitting/receiving antenna

5.8. DESCRIPTION OF TEST SETUP

SUPPORT EQUIPMENT

Item	Equipment	Brand Name	Model Name	P/N
1	Laptop	ThinkPad	T460S	SL10K24796 JS
2	USB TO UART	/	/	/

I/O CABLES

Item	Port	Connector Type	Cable Type	Cable Length(m)	Remarks
1	USB	/	/	0.5	/

Note: The USB cable is for debugging only.

ACCESSORIES

Item	Accessory	Brand Name	Model Name	Description
1	/	/	/	/

TEST SETUP

The EUT can work in engineering mode with a software through a Laptop.

SETUP DIAGRAM FOR TESTS

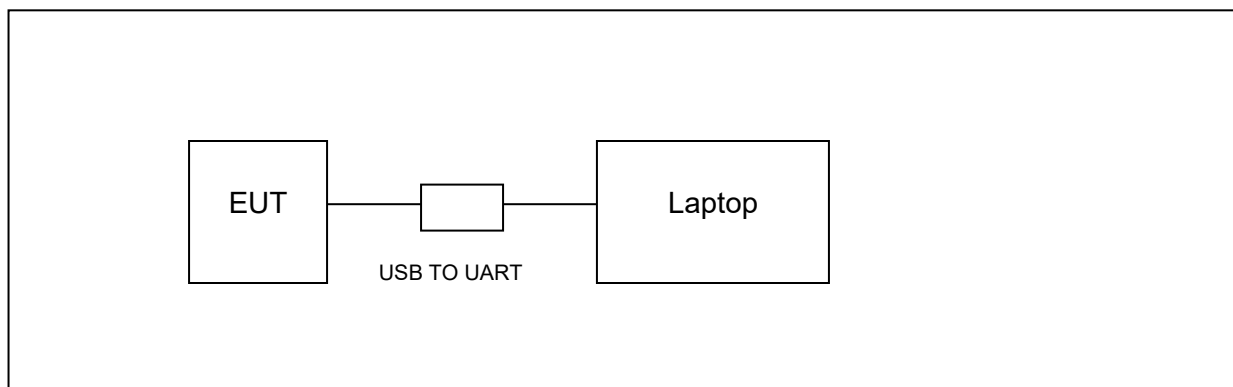



6. MEASURING INSTRUMENT AND SOFTWARE USED

Conducted Emissions						
Instrument						
Used	Equipment	Manufacturer	Model No.	Serial No.	Last Cal.	Next Cal.
<input checked="" type="checkbox"/>	EMI Test Receiver	R&S	ESR3	101961	Dec.10,2018	Dec.10,2019
<input checked="" type="checkbox"/>	Two-Line V- Network	R&S	ENV216	101983	Dec.10,2018	Dec.10,2019
<input checked="" type="checkbox"/>	Artificial Mains Networks	Schwarzbeck	NSLK 8126	8126465	Dec.10,2018	Dec.10,2019
Software						
Used	Description	Manufacturer	Name	Version		
<input checked="" type="checkbox"/>	Test Software for Conducted disturbance	Farad	EZ-EMC	Ver. UL-3A1		
Radiated Emissions						
Instrument						
Used	Equipment	Manufacturer	Model No.	Serial No.	Last Cal.	Next Cal.
<input checked="" type="checkbox"/>	MXE EMI Receiver	KESIGHT	N9038A	MY56400 036	Dec.10,2018	Dec.10,2019
<input checked="" type="checkbox"/>	Hybrid Log Periodic Antenna	TDK	HLP-3003C	130960	Sep.17, 2018	Sep.17, 2021
<input checked="" type="checkbox"/>	Preamplifier	HP	8447D	2944A090 99	Dec.10,2018	Dec.10,2019
<input checked="" type="checkbox"/>	EMI Measurement Receiver	R&S	ESR26	101377	Dec.10,2018	Dec.10,2019
<input checked="" type="checkbox"/>	Horn Antenna	TDK	HRN-0118	130939	Sep.17, 2018	Sep.17, 2021
<input checked="" type="checkbox"/>	High Gain Horn Antenna	Schwarzbeck	BBHA-9170	691	Aug.11, 2018	Aug.11, 2021
<input checked="" type="checkbox"/>	Preamplifier	TDK	PA-02-0118	TRS-305- 00066	Dec.10,2018	Dec.10,2019
<input checked="" type="checkbox"/>	Preamplifier	TDK	PA-02-2	TRS-307- 00003	Dec.10,2018	Dec.10,2019
<input checked="" type="checkbox"/>	Loop antenna	Schwarzbeck	1519B	00008	Jan.07, 2019	Jan.07, 2022
<input checked="" type="checkbox"/>	Band Reject Filter	Wainwright	WRCJV8- 2350-2400- 2483.5- 2533.5-40SS	4	Dec.10,2018	Dec.10,2019
<input checked="" type="checkbox"/>	High Pass Filter	Wi	WHKX10- 2700-3000- 18000-40SS	23	Dec.10,2018	Dec.10,2019
Software						
Used	Description	Manufacturer	Name	Version		
<input checked="" type="checkbox"/>	Test Software for Radiated disturbance	Farad	EZ-EMC	Ver. UL-3A1		



Other instruments						
Used	Equipment	Manufacturer	Model No.	Serial No.	Last Cal.	Next Cal.
<input checked="" type="checkbox"/>	Spectrum Analyzer	Keysight	N9030A	MY55410512	Dec.10,2018	Dec.10,2019
<input checked="" type="checkbox"/>	Power Meter	Keysight	N1911A	MY55416024	Dec.10,2018	Dec.10,2019
<input checked="" type="checkbox"/>	Power Sensor	Keysight	U2021XA	MY5100022	Dec.10,2018	Dec.10,2019

7. MEASUREMENT METHODS

No.	Test Item	KDB Name	Section
1	6dB Bandwidth	KDB 558074 D01 DTS Meas Guidance v05r02	8.2
2	Peak Output Power	KDB 558074 D01 DTS Meas Guidance v05r02	8.3.1.3/8.3.2.3
3	Power Spectral Density	KDB 558074 D01 DTS Meas Guidance v05r02	8.4
4	Out-of-band emissions in non-restricted bands	KDB 558074 D01 DTS Meas Guidance v05r02	8.5
5	Out-of-band emissions in restricted bands	KDB 558074 D01 DTS Meas Guidance v05r02	8.6
6	Band-edge	KDB 558074 D01 DTS Meas Guidance v05r02	8.7
7	Conducted Emission Test For AC Power Port	ANSI C63.10-2013	6.2



8. ANTENNA PORT TEST RESULTS

8.1. ON TIME AND DUTY CYCLE

LIMITS

None; for reporting purposes only

PROCEDURE

KDB 558074 Zero-Span Spectrum Analyzer Method

TEST SETUP

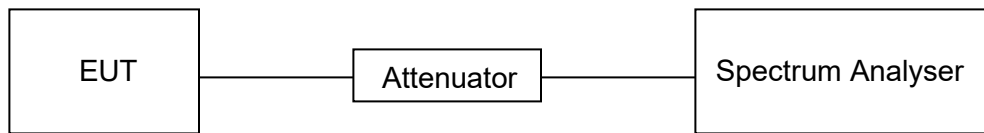

TEST ENVIRONMENT

Temperature	22.3°C	Relative Humidity	56%
Atmosphere Pressure	101kPa	Test Voltage	DC 3.3V

RESULTS

ANTENNA 1

Mode	On Time (msec)	Period (msec)	Duty Cycle x (Linear)	Duty Cycle (%)	Duty Cycle Correction Factor (dB)	1/T Minimum VBW (KHz)	Final setting For VBW (KHz)
11b	8.380	8.415	0.9958	99.58	0.018	0.119	0.01
11g	1.391	1.427	0.9748	97.48	0.111	0.719	1
11n20	1.300	1.335	0.9738	97.38	0.115	0.769	1
11n40	0.649	0.683	0.9502	95.02	0.222	1.541	2

Note:

Duty Cycle Correction Factor=10log (1/x).

Where: x is Duty Cycle (Linear)

Where: T is On Time

If that calculated VBW is not available on the analyzer then the next higher value should be used.

Antenna 0 and Antenna 1 has the same duty cycle, only Antenna 1 data show here.

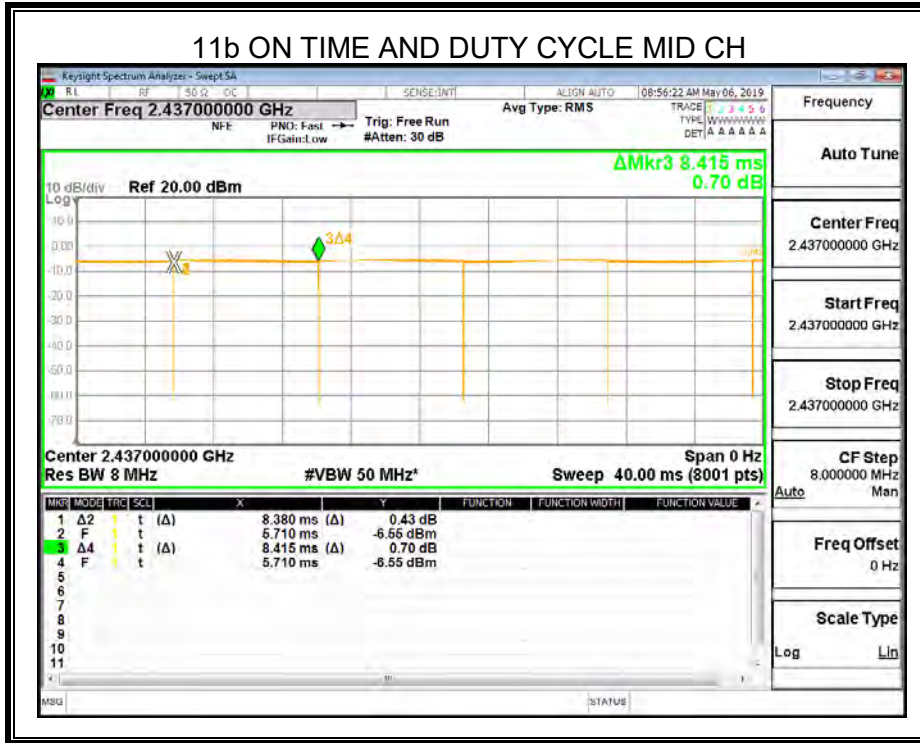

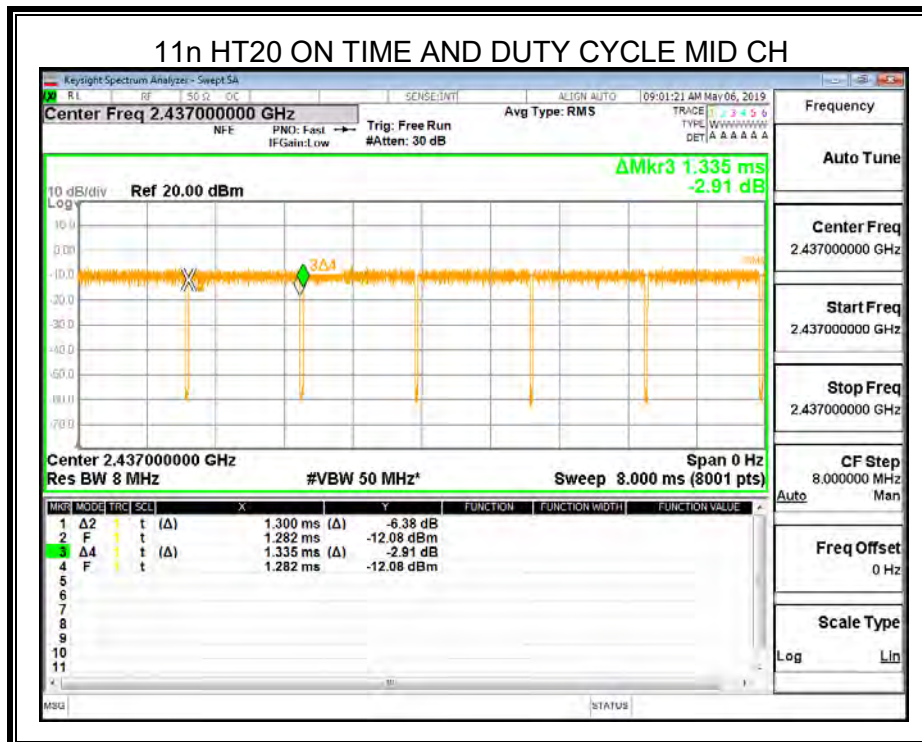
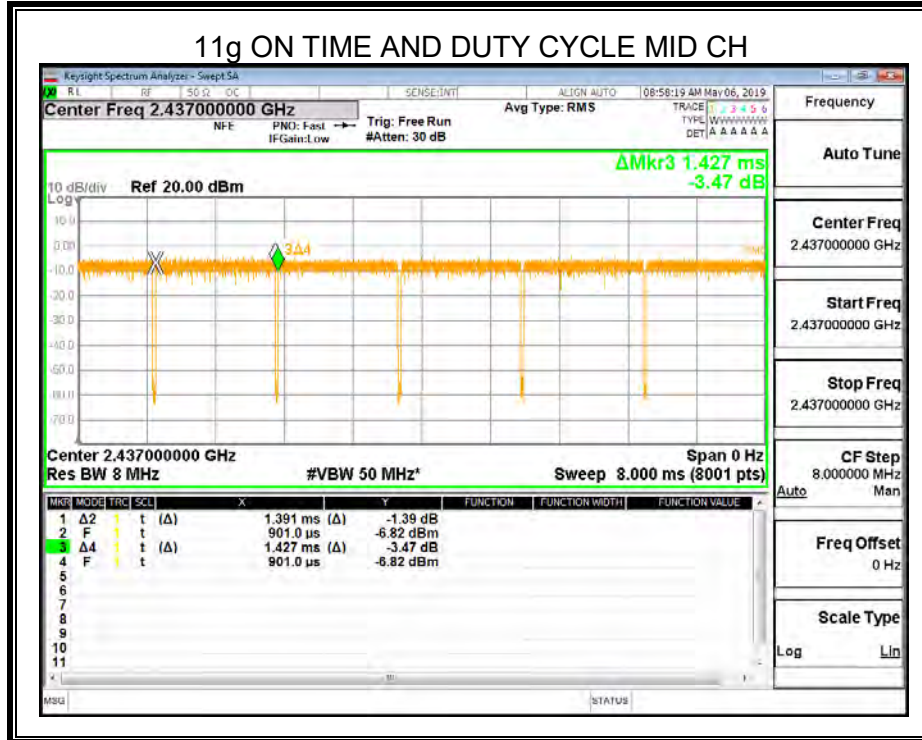

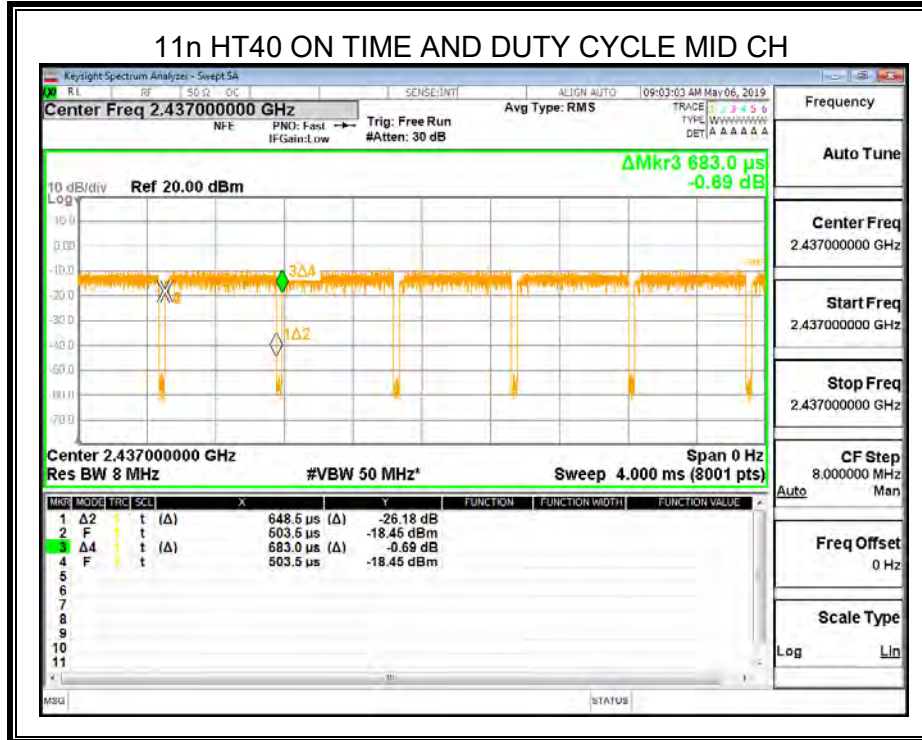

8.2. 6 dB DTS BANDWIDTH AND 99% OCCUPIED BANDWIDTH

LIMITS

CFR 47 FCC Part15 (15.247) Subpart C ISED RSS-247 ISSUE 2			
Section	Test Item	Limit	Frequency Range (MHz)
CFR 47 FCC 15.247(a)(2) ISED RSS-247 5.2 (a)	6 dB Bandwidth	≥ 500KHz	2400-2483.5
ISED RSS-Gen Clause 6.7	99% Occupied Bandwidth	For reporting purposes only.	2400-2483.5

TEST PROCEDURE

Connect the UUT to the spectrum analyser and use the following settings:

Center Frequency	The centre frequency of the channel under test
Detector	Peak
RBW	1% to 5% of the OBW
VBW	approximately 3×RBW
Span	approximately 2 to 3 times the OBW
Trace	Max hold
Sweep	Auto couple

Allow the trace to stabilize and measure the maximum width of the emission that is constrained by the frequencies associated with the two outermost amplitude points (upper and lower frequencies) that are attenuated by 6 dB and 99% relative to the maximum level measured in the fundamental emission.

TEST SETUP

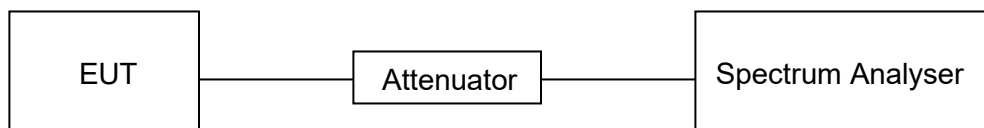



TEST ENVIRONMENT

Temperature	22.3°C	Relative Humidity	56%
Atmosphere Pressure	101kPa	Test Voltage	DC 3.3V

RESULTS

8.2.1. 802.11b SISO MODE

ANTENNA 1

Channel	6dB bandwidth (MHz)	99% bandwidth (MHz)	Limit (kHz)	Result
Low	9.557	13.863	≥500	Pass
Middle	8.587	13.453	≥500	Pass
High	8.552	13.590	≥500	Pass

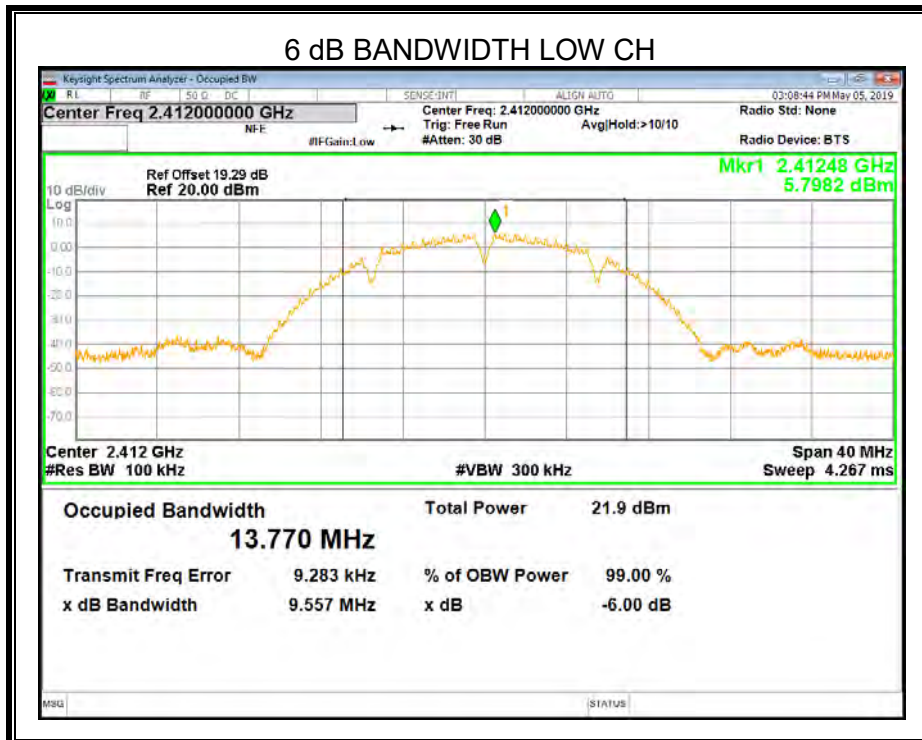

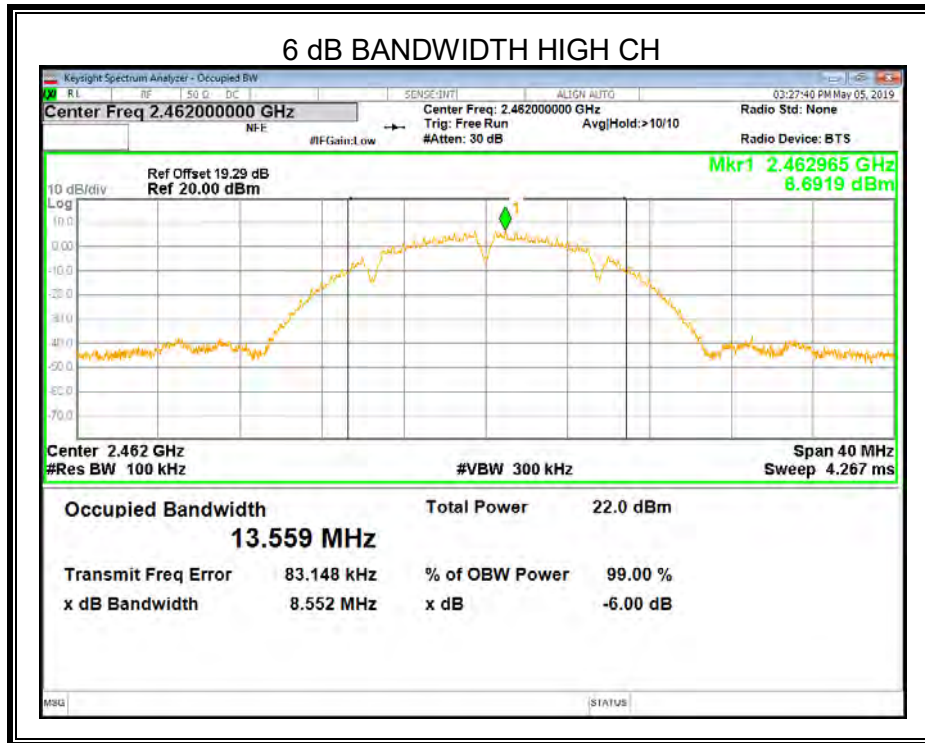
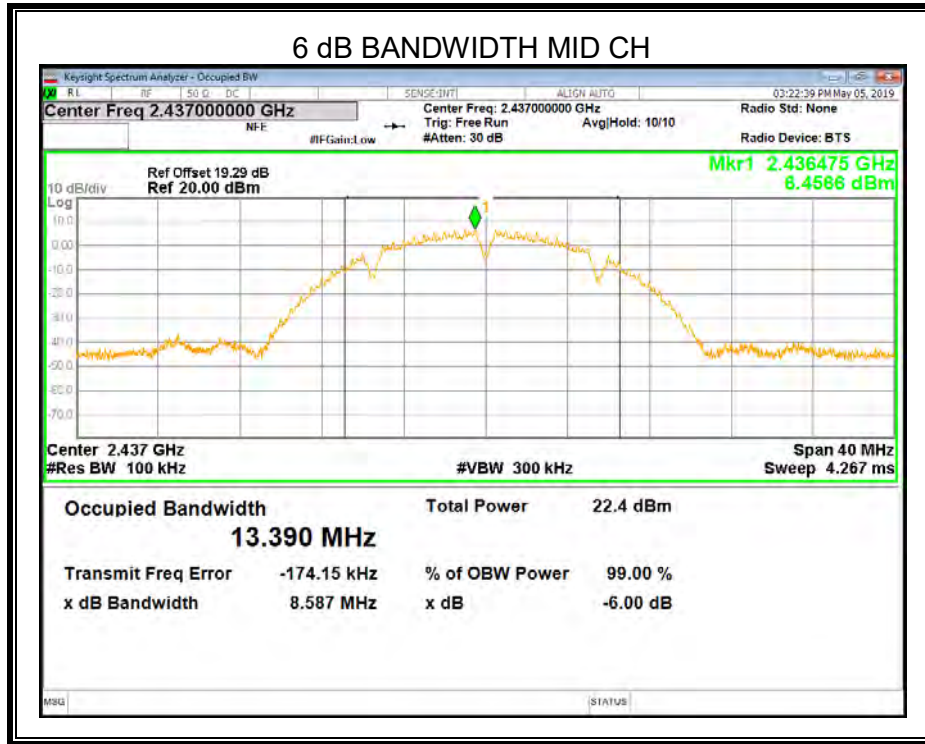

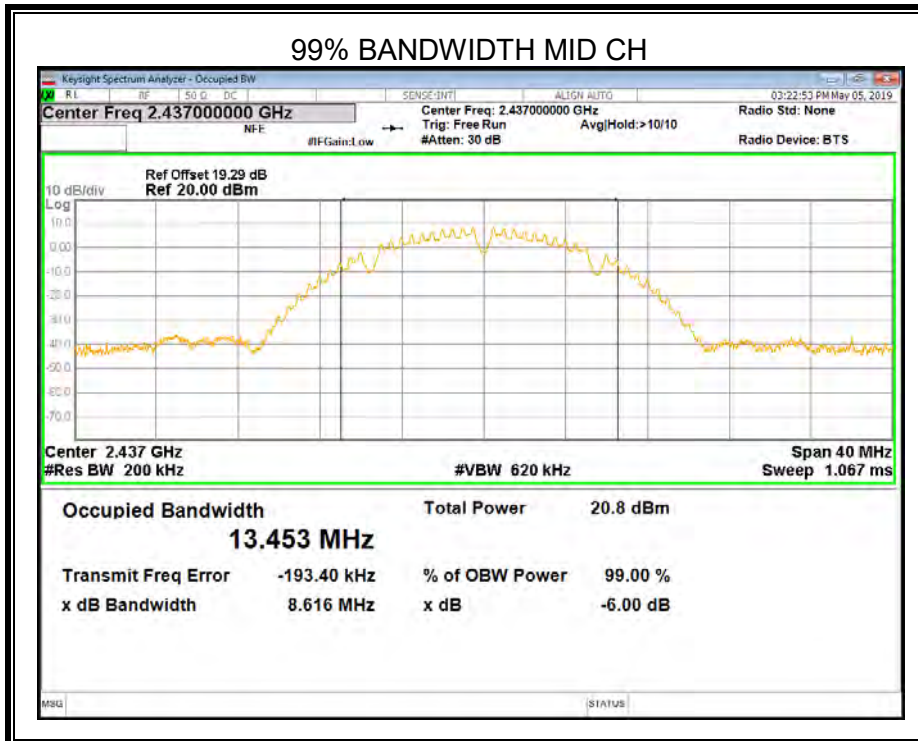
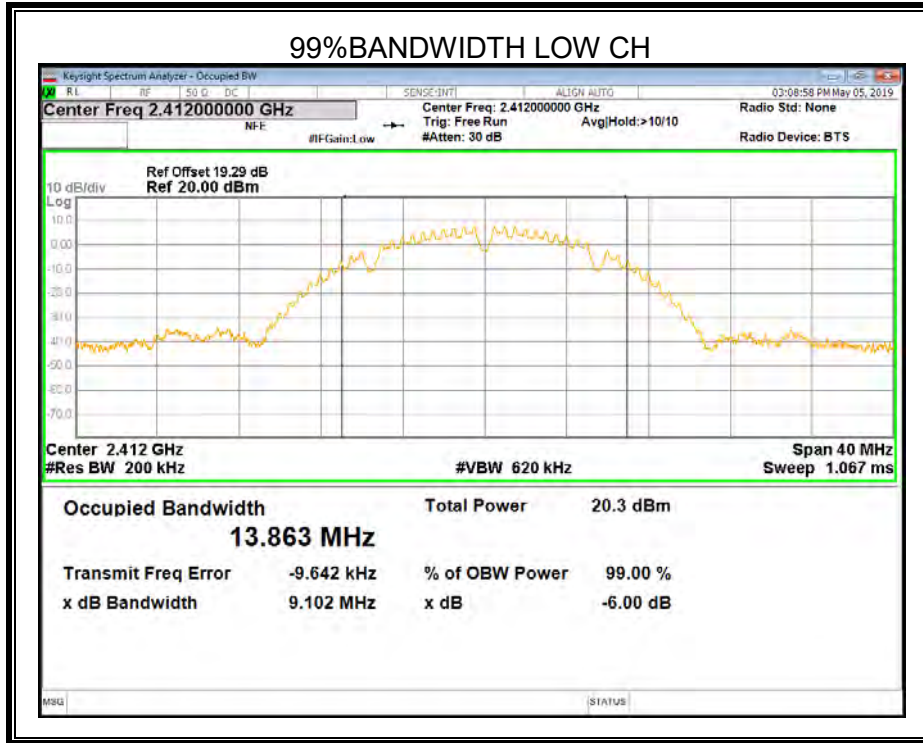

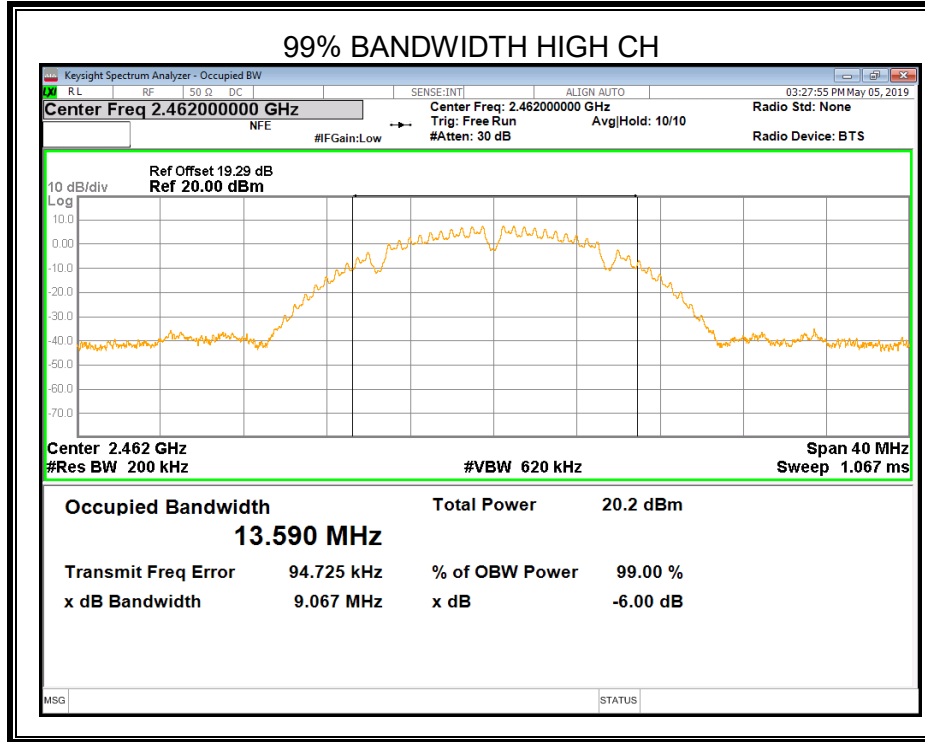

Note: All the modes and antenna ports had been tested, only the worst data recorded in the report.

8.2.2. 802.11g SISO MODE

ANTENNA 1

Channel	6dB bandwidth (MHz)	99% bandwidth (MHz)	Limit (kHz)	Result
Low	15.08	16.565	≥500	Pass
Middle	15.32	16.427	≥500	Pass
High	15.12	16.466	≥500	Pass

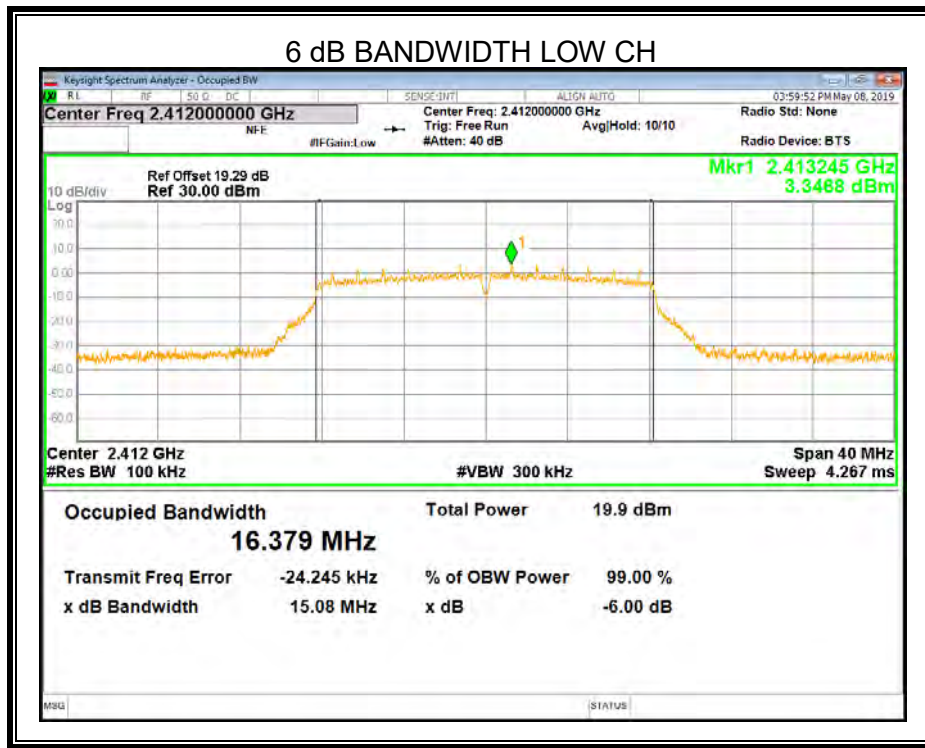

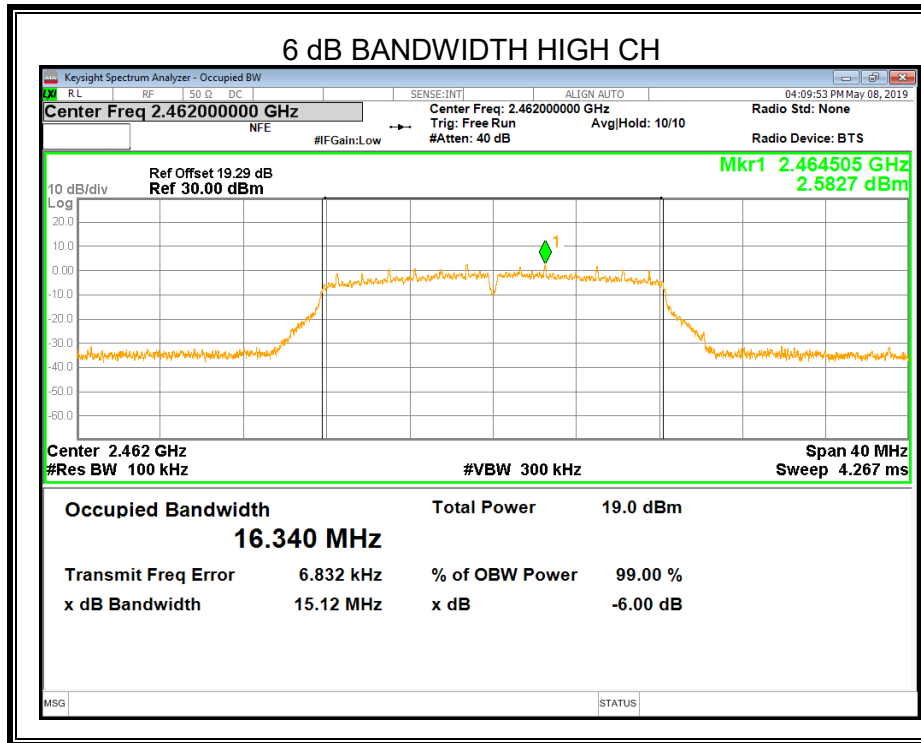
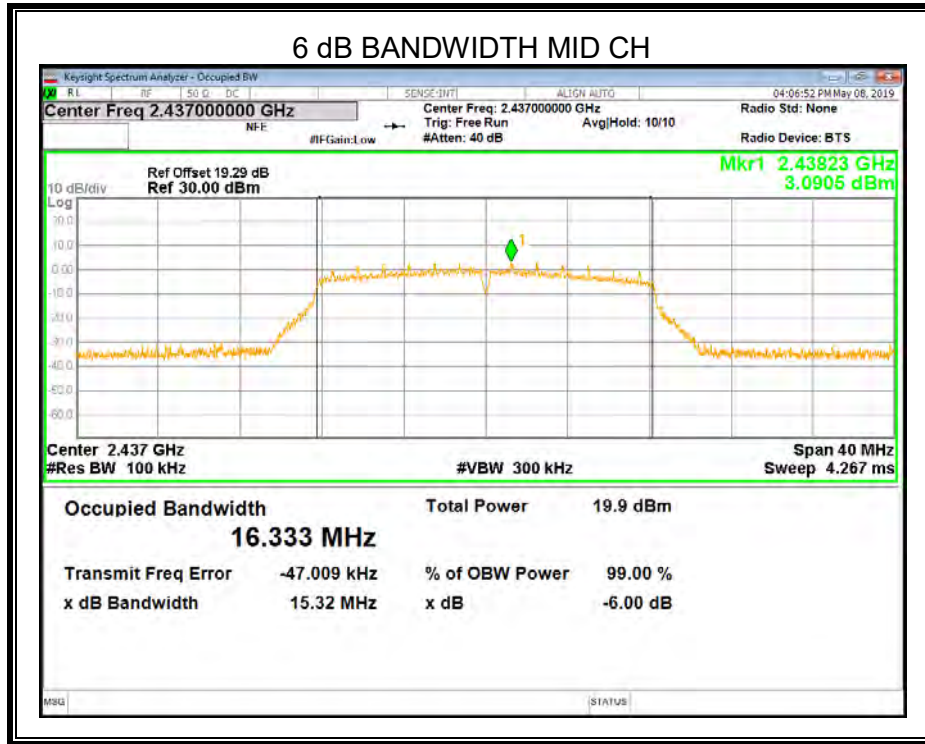

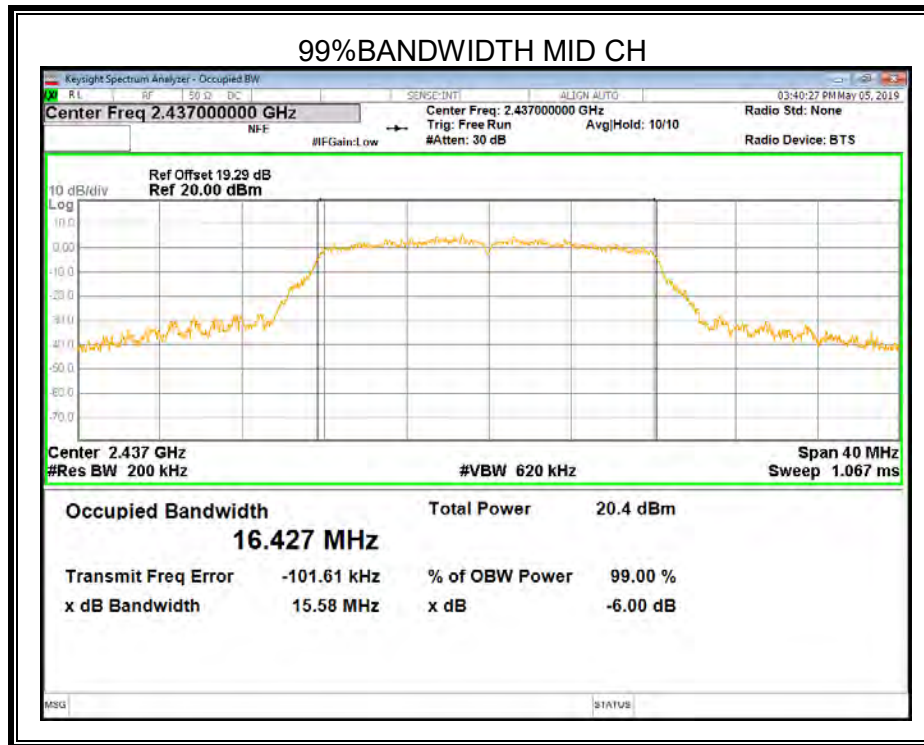
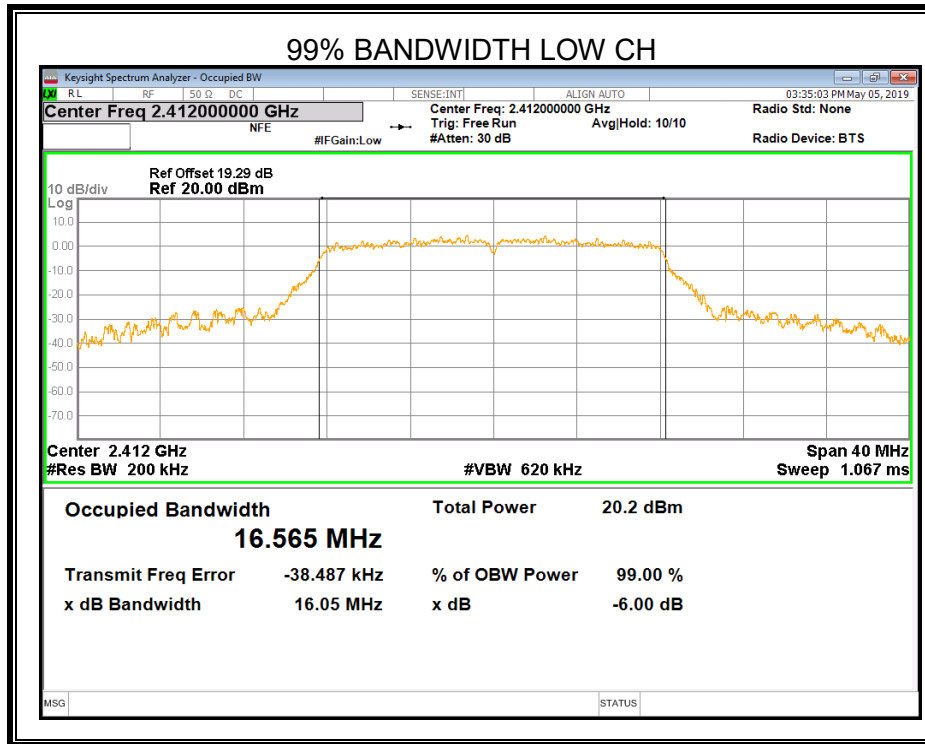

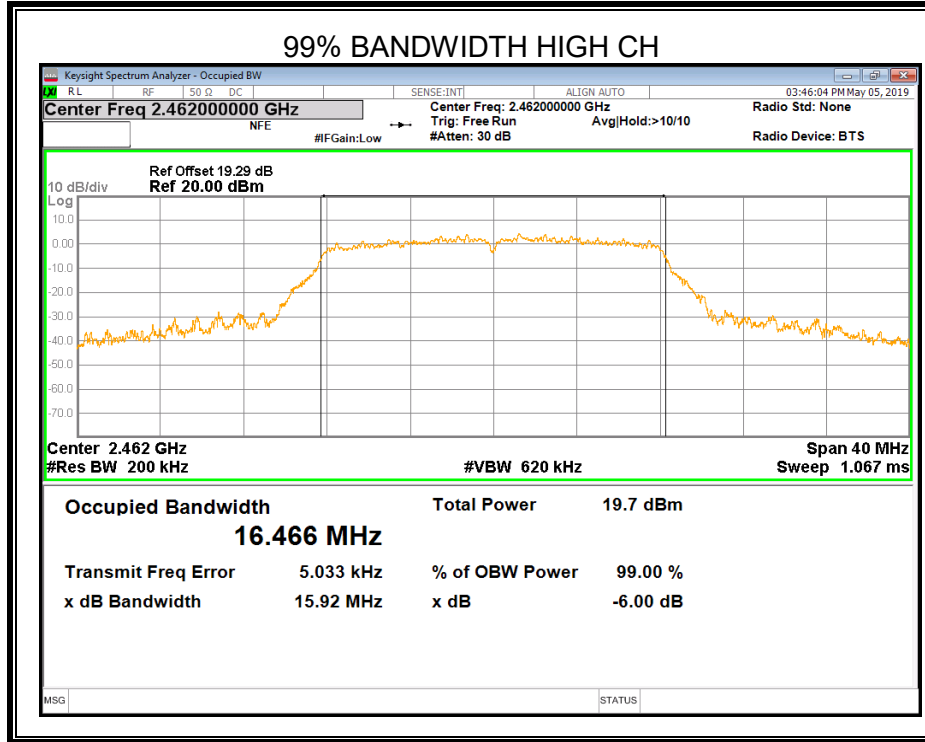

Note: All the modes and antenna ports had been tested, only the worst data recorded in the report.



8.2.3. 802.11n HT20 MIMO MODE

ANTENNA 1

Channel	6dB bandwidth (MHz)	99% bandwidth (MHz)	Limit (kHz)	Result
Low	15.13	17.586	≥500	Pass
Middle	15.06	17.498	≥500	Pass
High	15.11	17.534	≥500	Pass

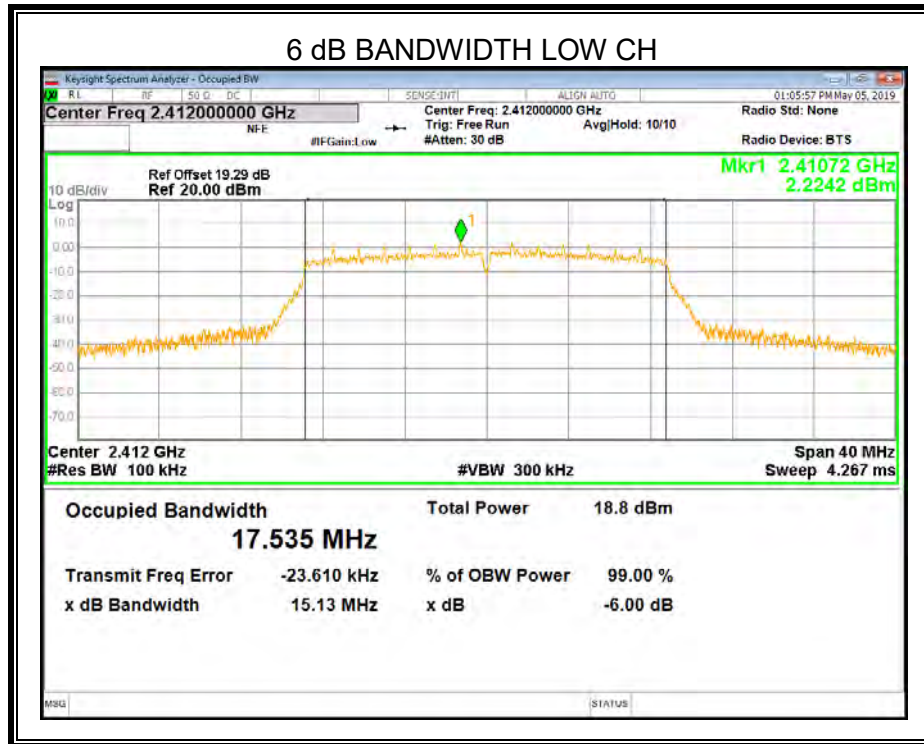

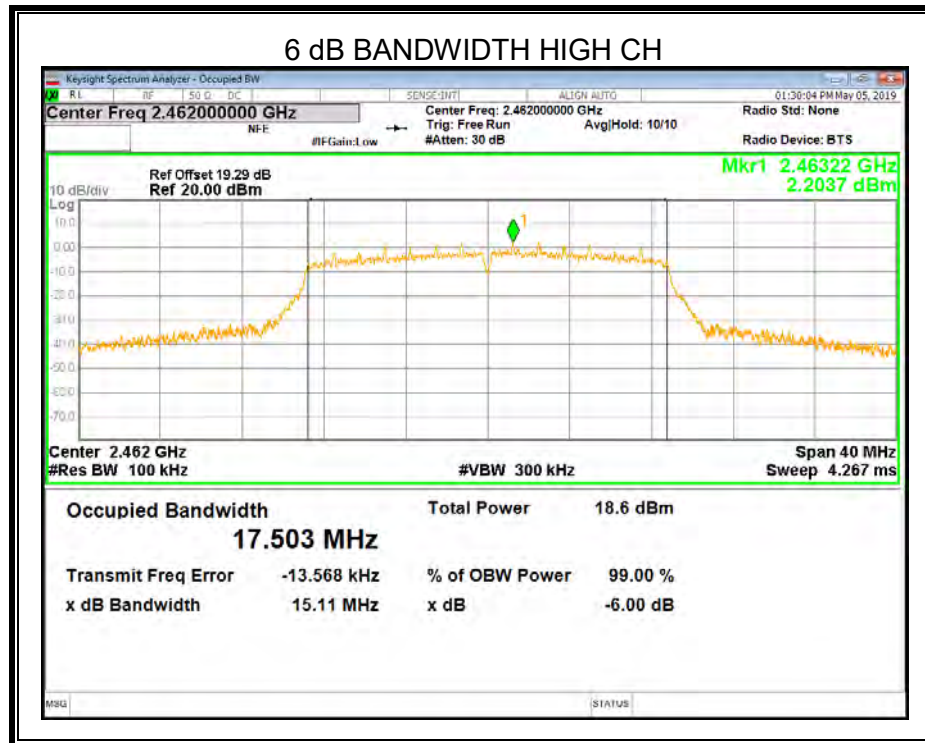
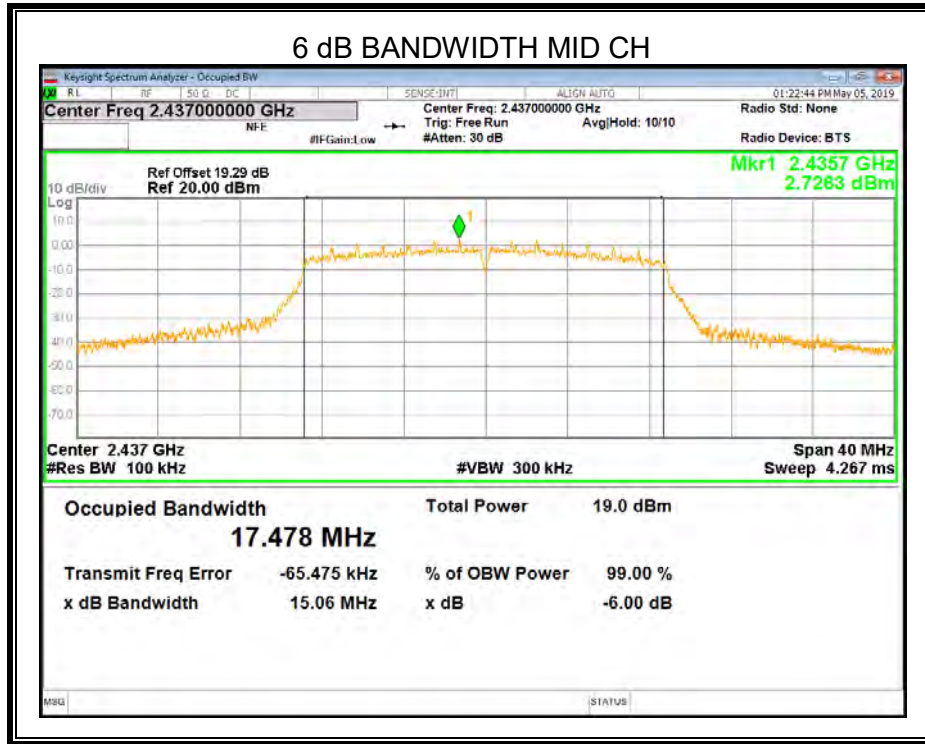

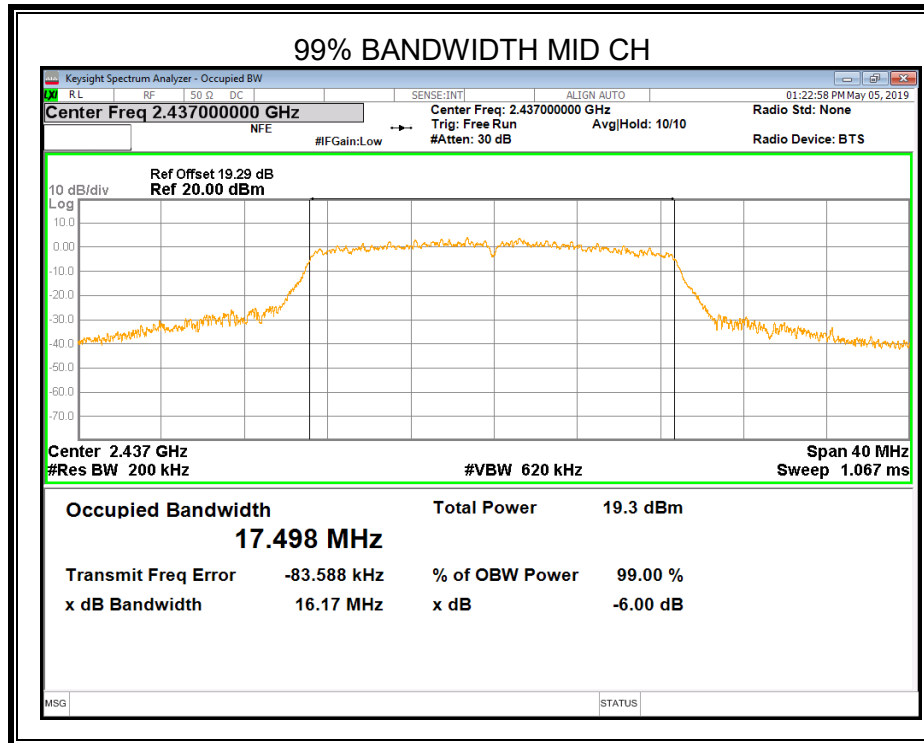
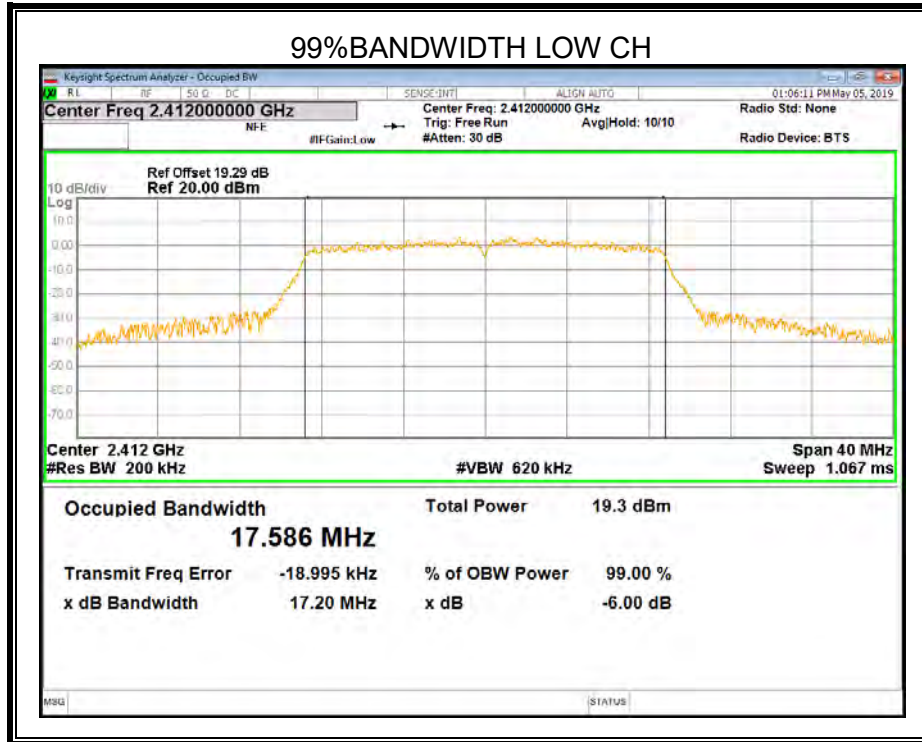

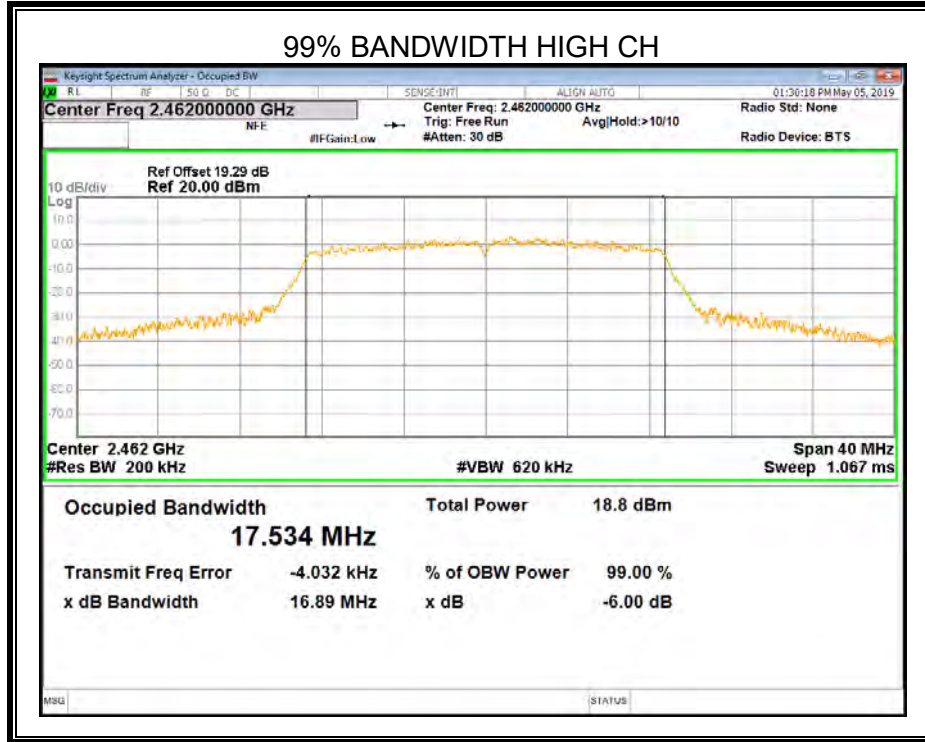

Note: All the modes and antenna ports had been tested, only the worst data recorded in the report.

8.2.4. 802.11n HT40 MIMO MODE

ANTENNA 1

Channel	6dB bandwidth (MHz)	99% bandwidth (MHz)	Limit (kHz)	Result
Low	35.10	36.138	≥500	Pass
Middle	35.10	36.104	≥500	Pass
High	35.12	36.139	≥500	Pass

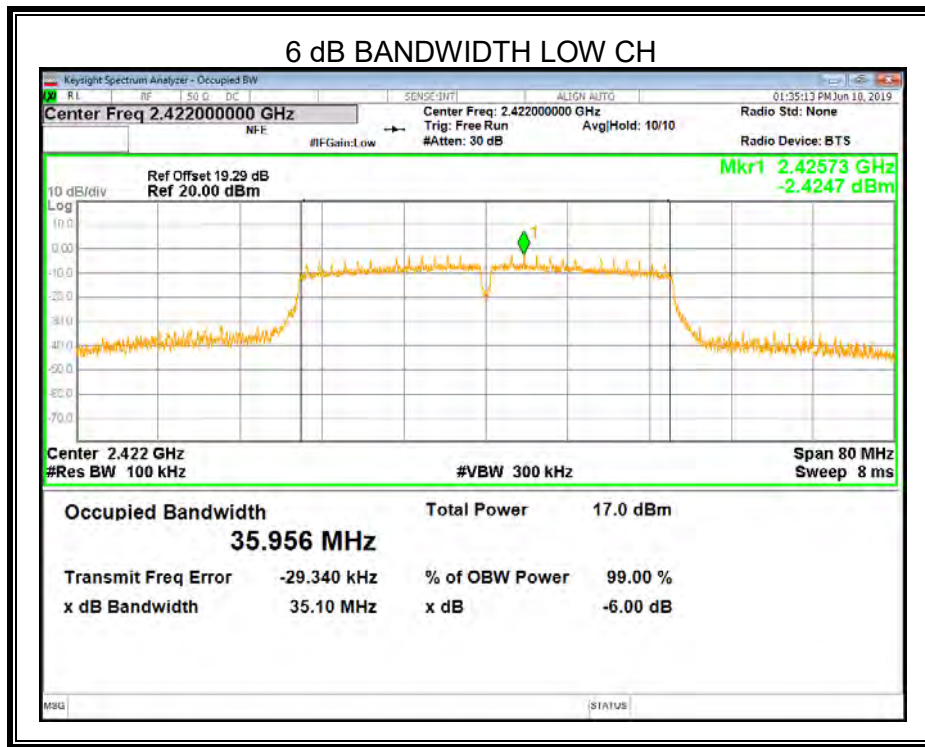

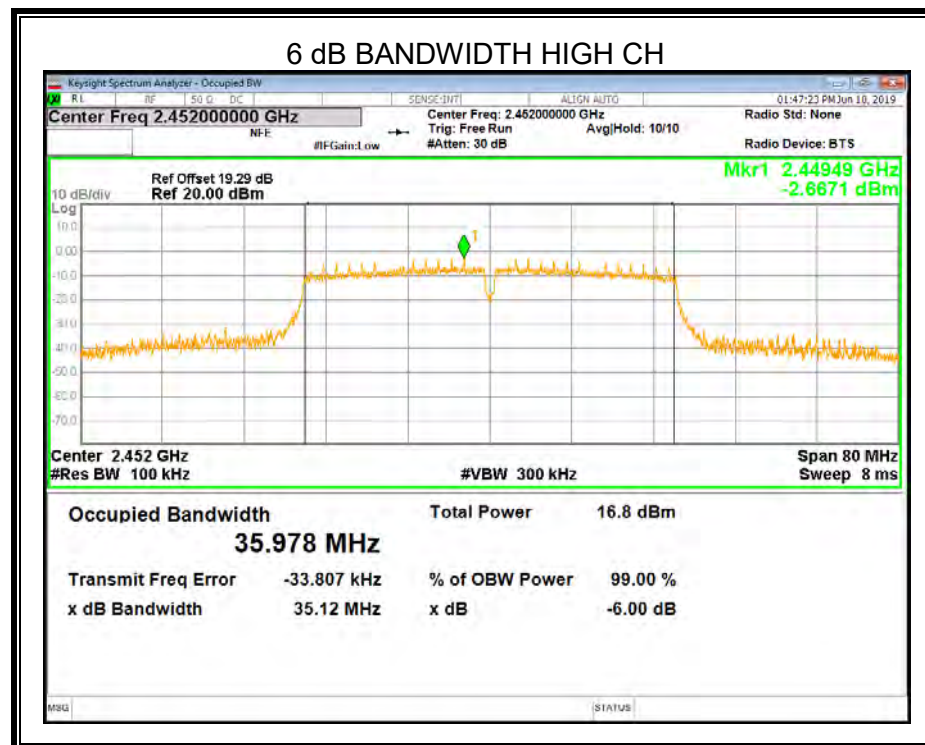
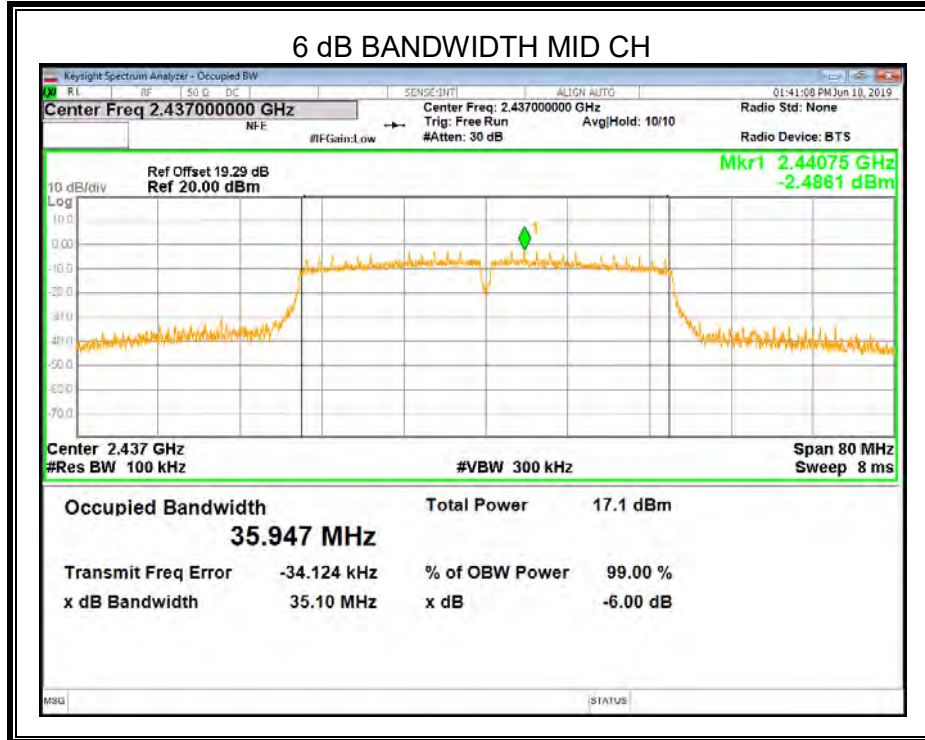

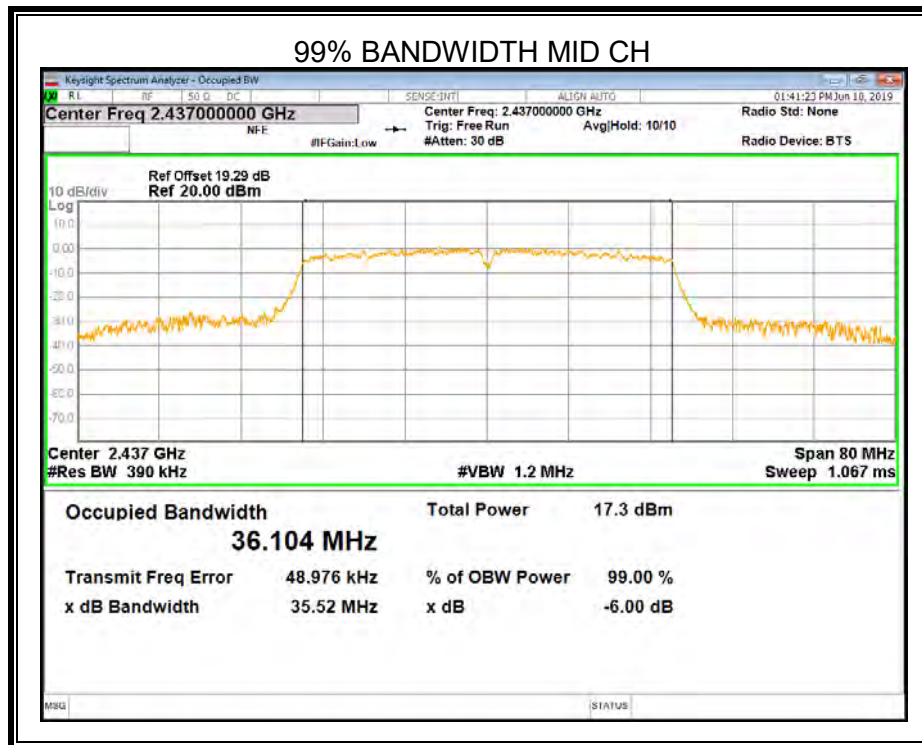
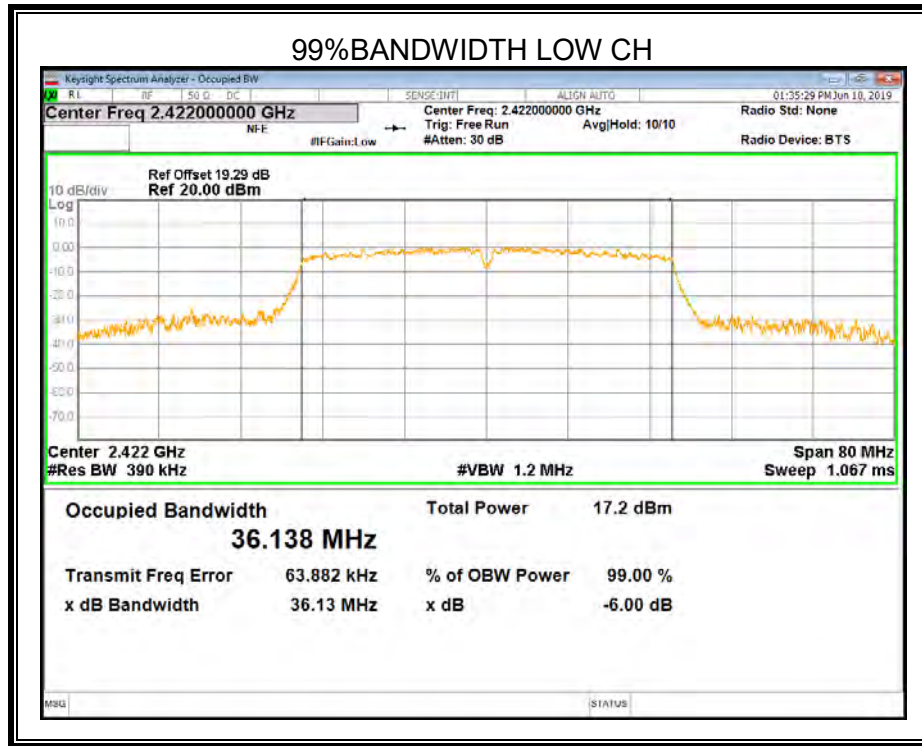

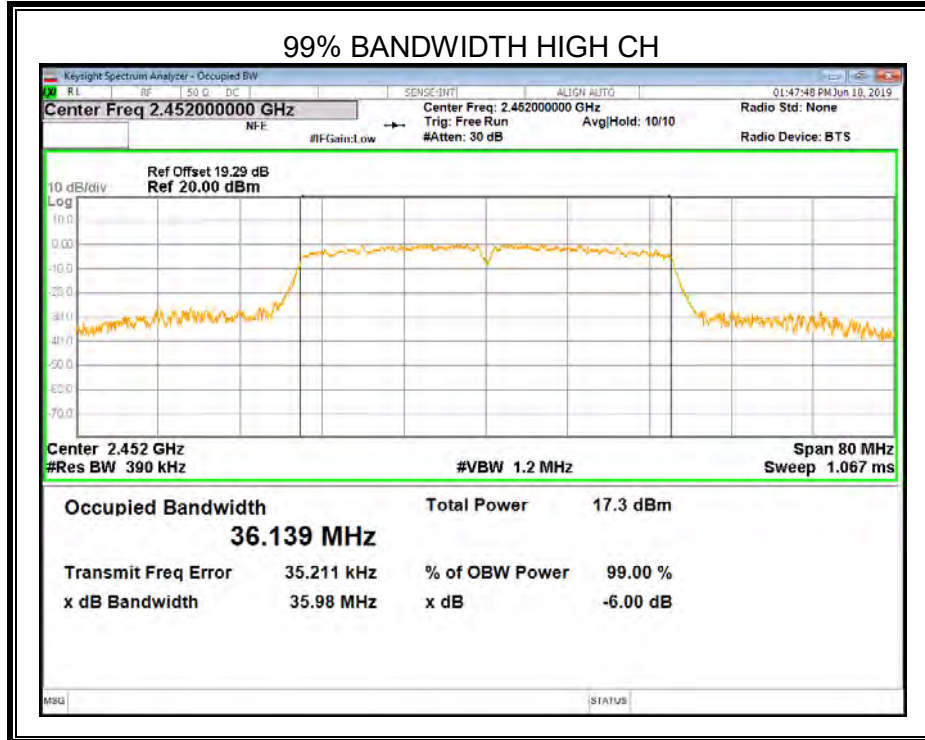

Note: All modes and antennas had been tested, but only the worst data recorded in the report.



8.3. PEAK CONDUCTED OUTPUT POWER

LIMITS

CFR 47 FCC Part15 (15.247) Subpart C ISED RSS-247 ISSUE 2			
Section	Test Item	Limit	Frequency Range (MHz)
CFR 47 FCC 15.247(b)(3) ISED RSS-247 5.4 (d)	Peak Output Power	1 watt or 30dBm (See Note 1/2)	2400-2483.5
1. The total conducted output power shall be reduced by 1 dB below the specified limits for each 3 dB that the directional gain of the antenna/antenna array exceeds 6 dBi 2. Limit=30dBm – 1. Directional gain = GANT + 10 log(NANT) dBi, where NANT is the number of outputs, GANT is the Antenna gain.			

TEST PROCEDURE

Place the EUT on the table and set it in the transmitting mode.
 Remove the antenna from the EUT and then connect a low loss RF cable from the antenna port to the Power sensor.
 Measure peak power each channel.
 Peak Detector use for Peak result.
 AVG Detector use for AVG result.

TEST SETUP

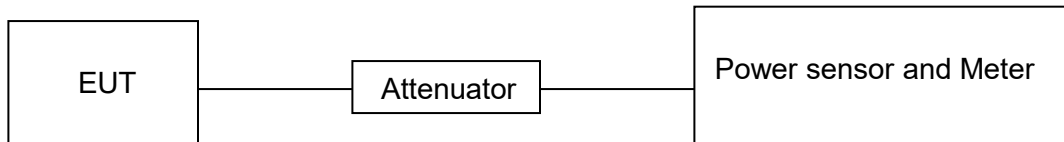

TEST ENVIRONMENT

Temperature	23.2°C	Relative Humidity	56%
Atmosphere Pressure	101kPa	Test Voltage	DC 3.3V



RESULTS

8.3.1. 802.11b SISO MODE

Frequency (MHz)	ANT	Maximum PK Conducted Output Power (dBm)		Limit	Result
		Single	Total		
Low	0	17.52	/	30	PASS
	1	18.26			
Middle	0	18.06			
	1	18.66			
High	0	17.57			
	1	18.72			

Frequency (MHz)	ANT	Maximum AV Conducted Output Power (dBm)		Limit	Result
		Single	Total		
Low	0	15.45	/	30	PASS
	1	16.15			
Middle	0	16.10			
	1	16.51			
High	0	15.61			
	1	16.58			



8.3.2. 802.11g SISO MODE

Frequency (MHz)	ANT	Maximum PK Conducted Output Power (dBm)		Limit	Result
		Single	Total		
Low	0	20.57	/	30	PASS
	1	20.87			
Middle	0	20.85			
	1	20.99			
High	0	19.95			
	1	20.61			

Frequency (MHz)	ANT	Maximum AV Conducted Output Power (dBm)		Limit	Result
		Single	Total		
Low	0	13.49	/	30	PASS
	1	13.96			
Middle	0	13.83			
	1	14.08			
High	0	12.88			
	1	13.64			



8.3.3. 802.11n HT20 MIMO MODE

Frequency (MHz)	ANT	Maximum PK Conducted Output Power (dBm)		Limit	Result
		Single	Total		
Low	0	19.71	22.72	29	PASS
	1	19.71			
Middle	0	19.78	22.79		
	1	19.78			
High	0	19.41	22.39		
	1	19.34			

Frequency (MHz)	ANT	Maximum AV Conducted Output Power (dBm)		Limit	Result
		Single	Total		
Low	0	12.88	15.91	29	PASS
	1	12.91			
Middle	0	13.01	15.95		
	1	12.86			
High	0	12.49	15.51		
	1	12.51			



8.3.4. 802.11n HT40 MIMO MODE

Frequency (MHz)	ANT	Maximum PK Conducted Output Power (dBm)		Limit	Result
		Single	Total		
Low	0	17.86	22.03	29	PASS
	1	19.93			
Middle	0	17.79	21.99		
	1	19.91			
High	0	17.77	21.97		
	1	19.89			

Frequency (MHz)	ANT	Maximum AV Conducted Output Power (dBm)		Limit	Result
		Single	Total		
Low	0	10.91	14.30	29	PASS
	1	11.64			
Middle	0	10.77	14.25		
	1	11.66			
High	0	10.81	14.30		
	1	11.73			

8.4. POWER SPECTRAL DENSITY

LIMITS

CFR 47 FCC Part15 (15.247) Subpart C ISED RSS-247 ISSUE 2			
Section	Test Item	Limit	Frequency Range (MHz)
CFR 47 FCC §15.247 (e) ISED RSS-247 5.2 (b)	Power Spectral Density	8 dBm/3 kHz (See Note 1/2)	2400-2483.5
1. If transmitting antennas of directional gain greater than 6 dBi are used, both the maximum conducted output power and the maximum power spectral density shall be reduced by the amount in dB that the directional gain of the antenna exceeds 6dBi. 2. Limit=8dBm – (Directional gain -6)dBi Directional gain = $G_{ANT} + 10 \log(N_{ANT})$ dBi, where N_{ANT} is the number of outputs, G_{ANT} is the Antenna gain.			

TEST PROCEDURE

Connect the UUT to the spectrum analyser and use the following settings:

Center Frequency	The centre frequency of the channel under test
Detector	Peak
RBW	$3 \text{ kHz} \leq \text{RBW} \leq 100 \text{ kHz}$
VBW	$\geq 3 \times \text{RBW}$
Span	1.5 x DTS bandwidth
Trace	Max hold
Sweep time	Auto couple.

Allow trace to fully stabilize and use the peak marker function to determine the maximum amplitude level within the RBW.

If measured value exceeds limit, reduce RBW (no less than 3 kHz) and repeat.

TEST SETUP

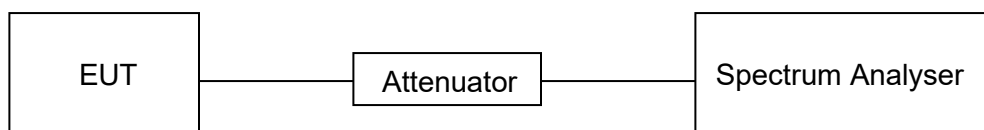



TEST ENVIRONMENT

Temperature	23.2°C	Relative Humidity	56%
Atmosphere Pressure	101kPa	Test Voltage	DC 3.3V

RESULTS

8.4.1. 802.11b SISO MODE

Frequency (MHz)	ANT	Power Spectral Density (dBm/3kHz)		Limit (dBm/3kHz)
		Single	Total	
Low	1	4.036	NA	8
Middle	1	5.706		
High	1	4.993		



ANTENNA 1

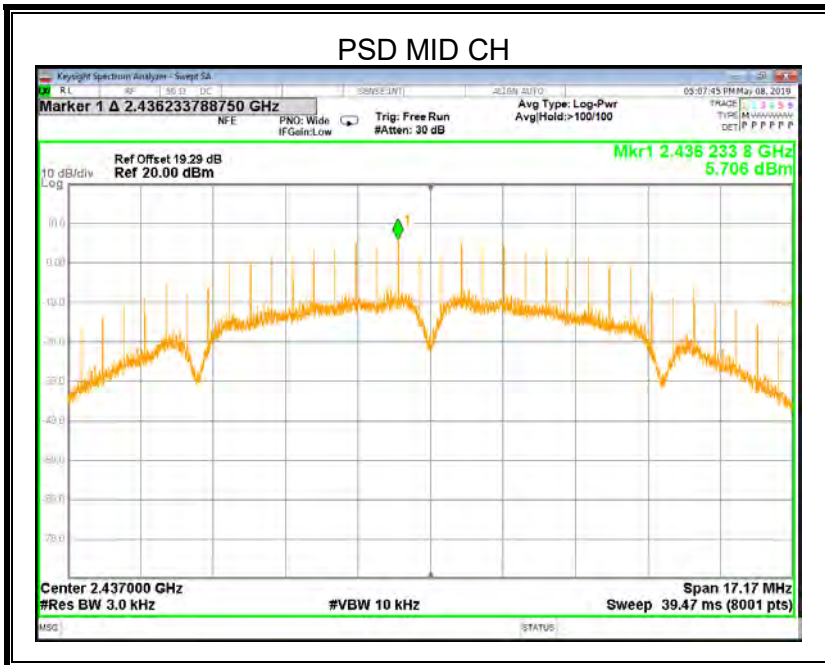
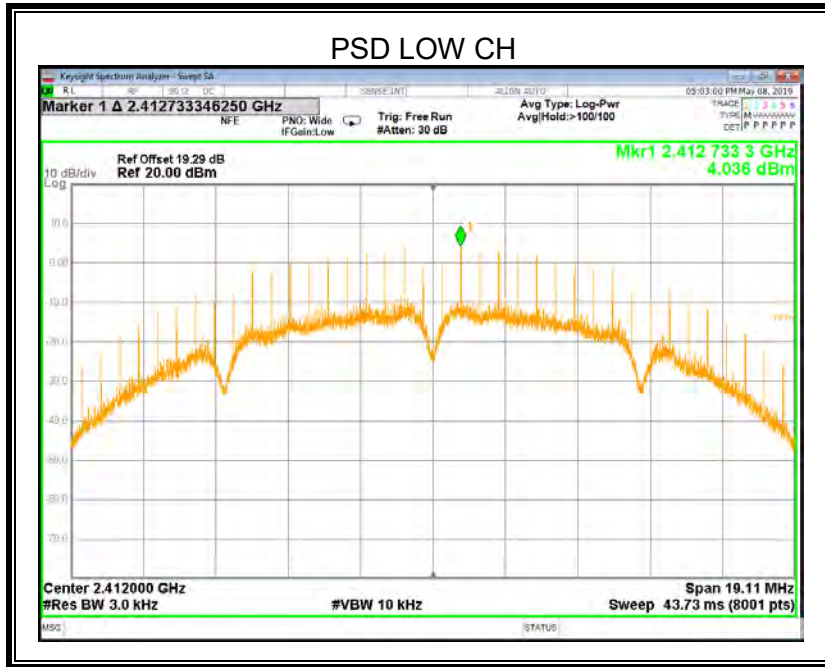

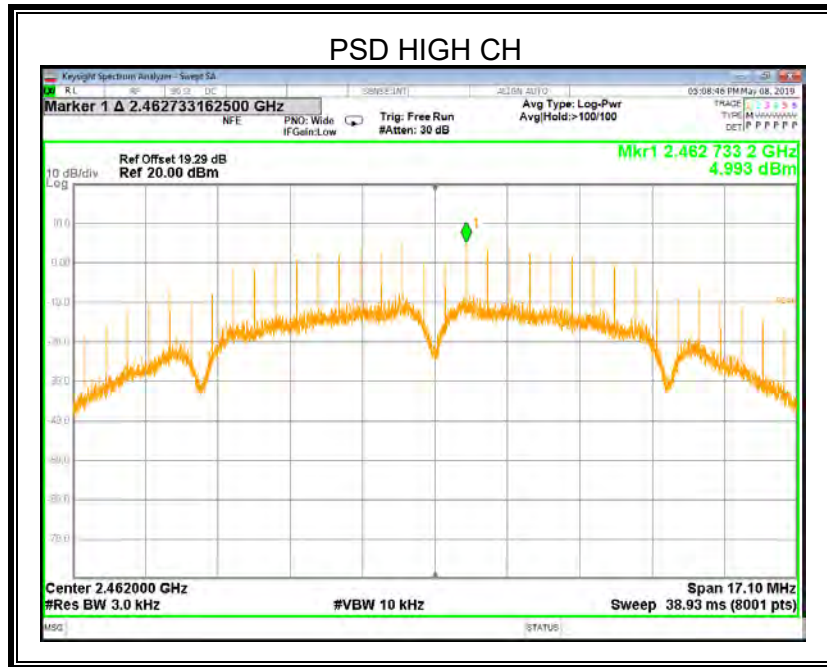

Note: All the modes and antenna ports had been tested, only the worst data recorded in the report.



8.4.1. 802.11g SISO MODE

Frequency (MHz)	ANT	Power Spectral Density (dBm/3kHz)		Limit (dBm/3kHz)
		Single	Total	
Low	1	-11.775	NA	8
Middle	1	-10.614		
High	1	-12.140		

ANTENNA1

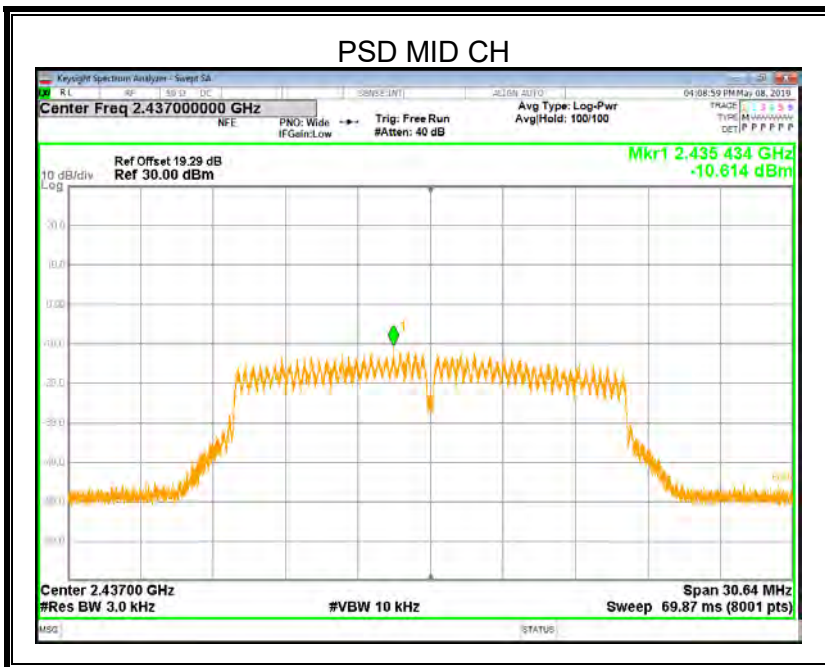
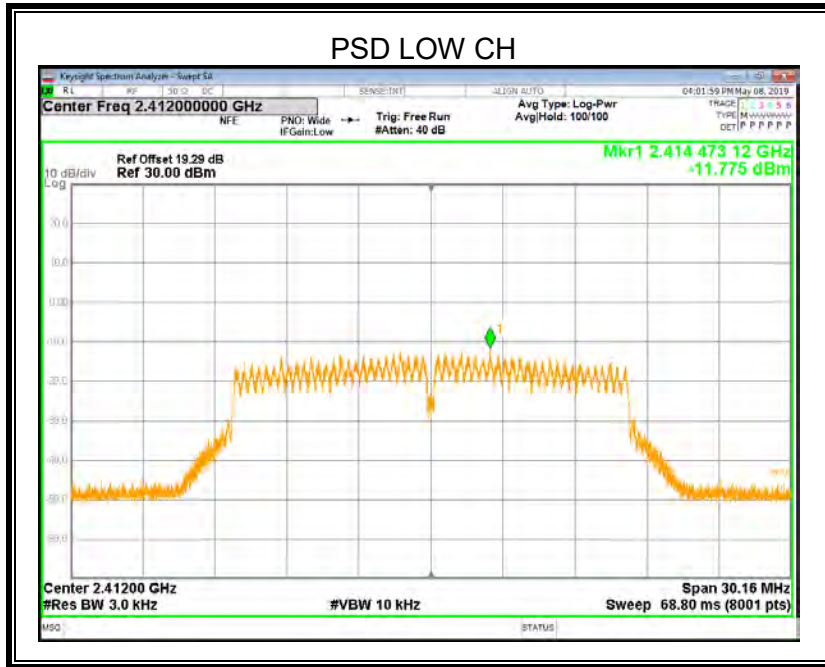

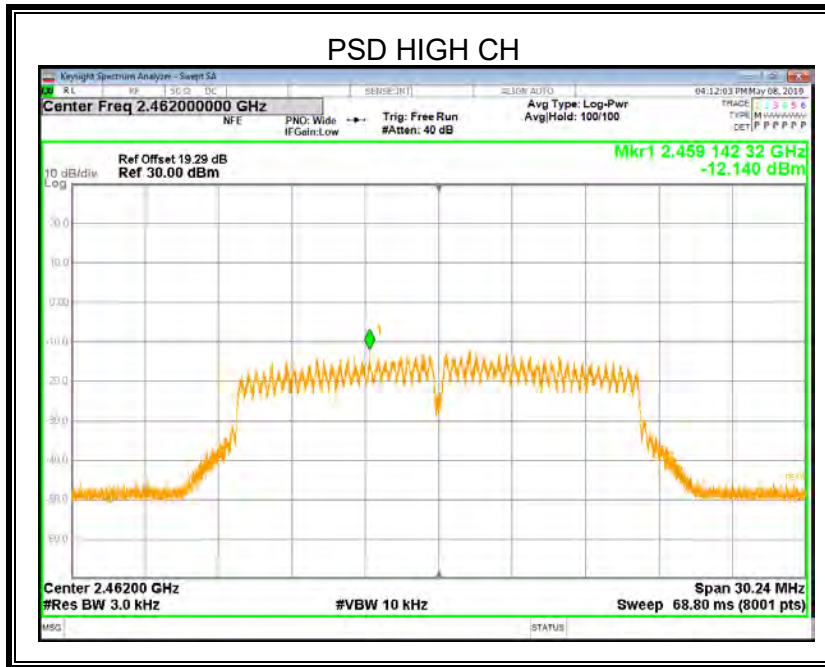

Note: All the modes and antenna ports had been tested, only the worst data recorded in the report.



8.4.2. 802.11n HT20 MIMO MODE

Frequency (MHz)	ANT	Power Spectral Density (dBm/3kHz)		Limit (dBm/3kHz)
		Single	Total	
Low	0	-12.072	-8.842	6.25
	1	-11.643		
Middle	0	-10.401	-8.156	
	1	-12.097		
High	0	-12.501	-9.557	
	1	-12.635		



ANTENNA 0

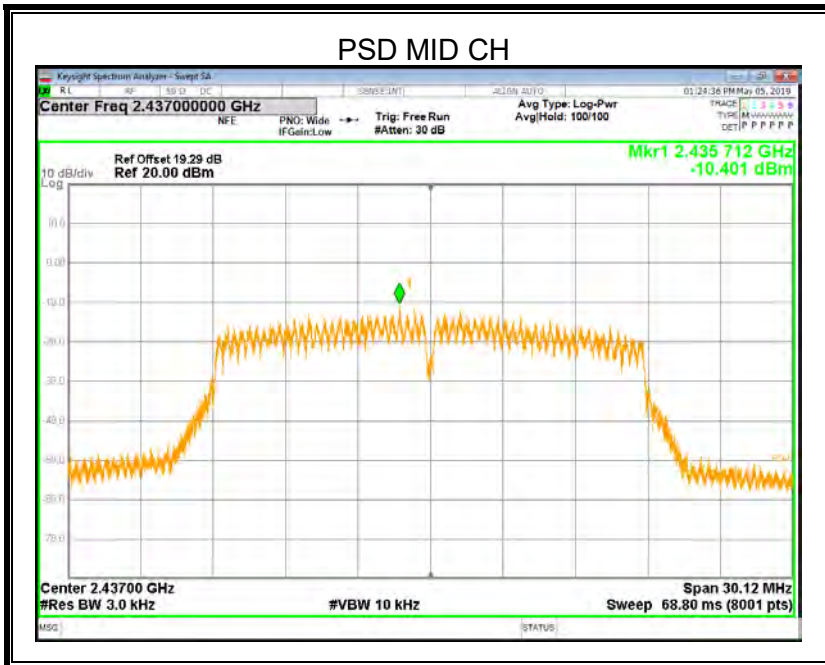
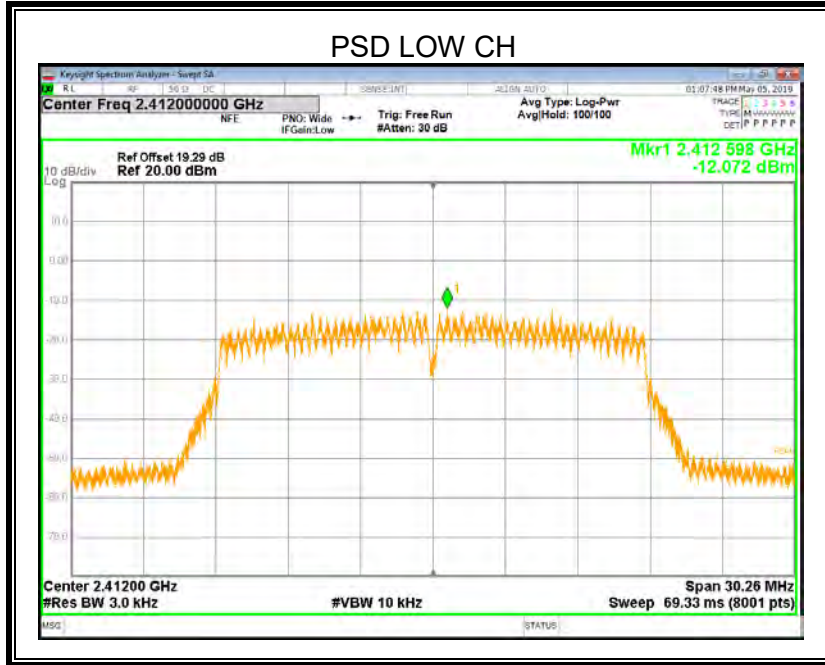

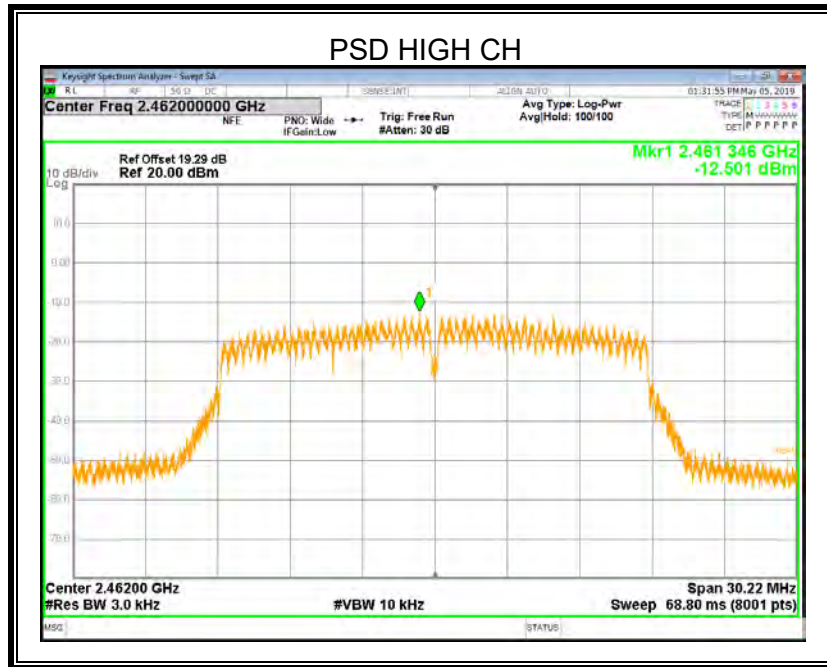

ANTENNA 1

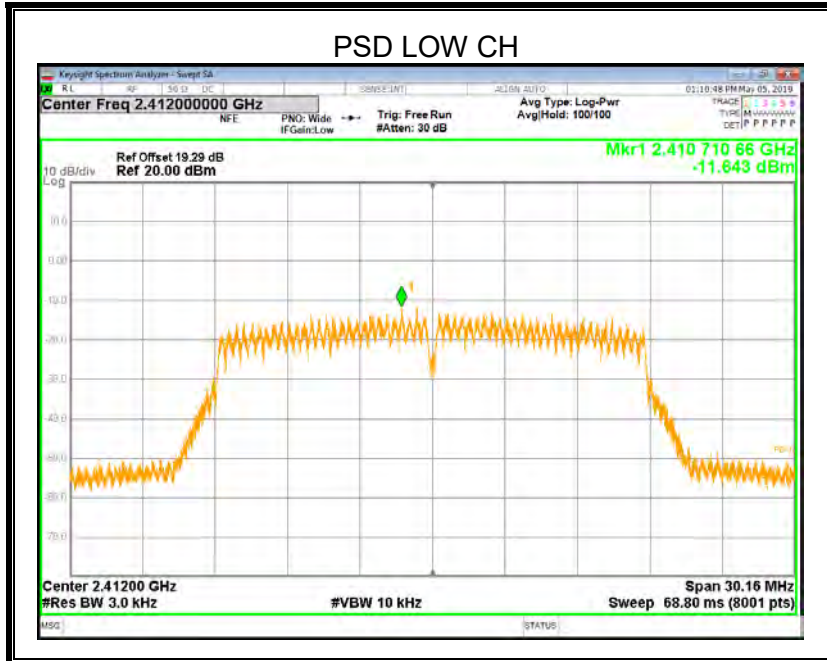

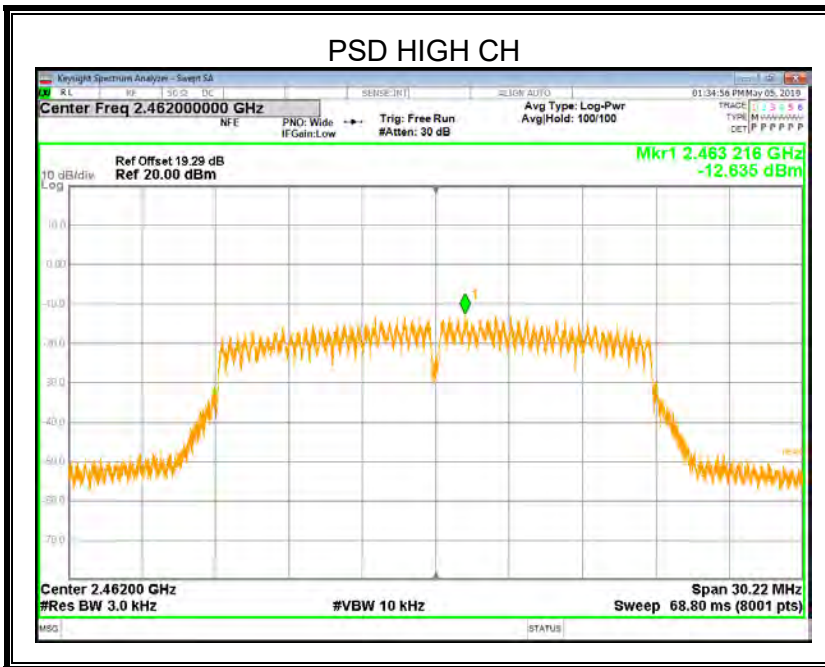
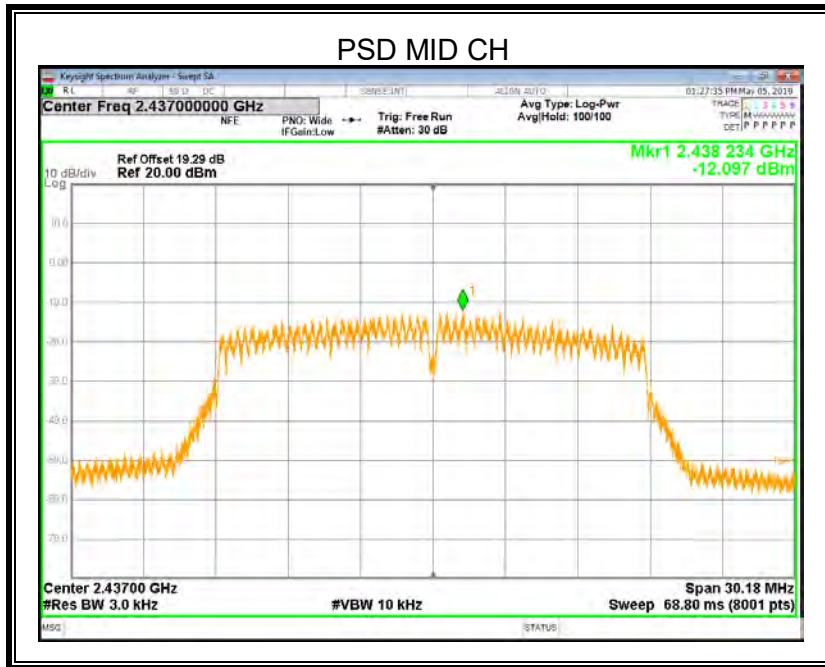



8.4.3. 802.11n HT40 MIMO MODE

Frequency (MHz)	ANT	Power Spectral Density (dBm/3kHz)		Limit (dBm/3kHz)
		Single	Total	
Low	0	-16.460	-13.499	6.25
	1	-16.560		
Middle	0	-17.828	-13.633	
	1	-15.714		
High	0	-17.877	-14.467	
	1	-17.111		



ANTENNA 0

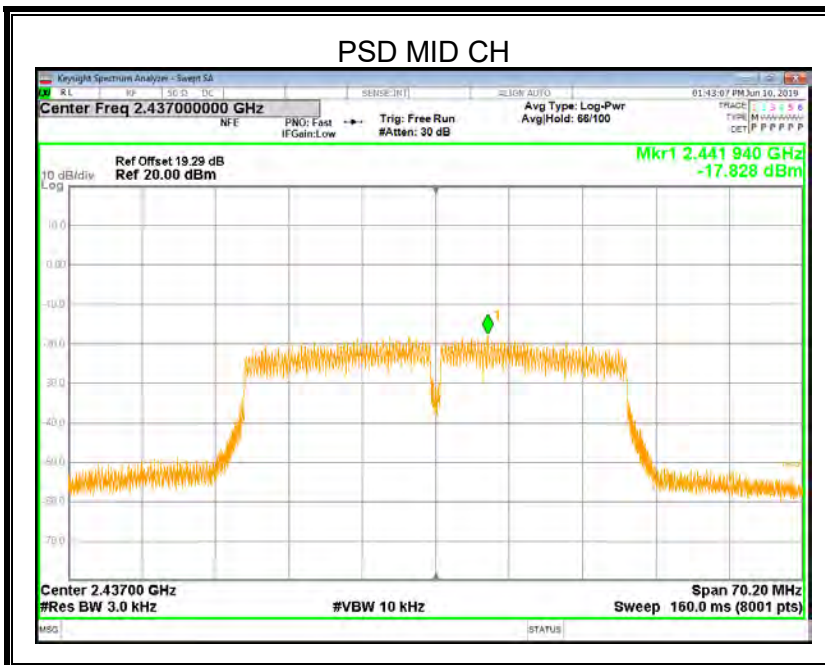
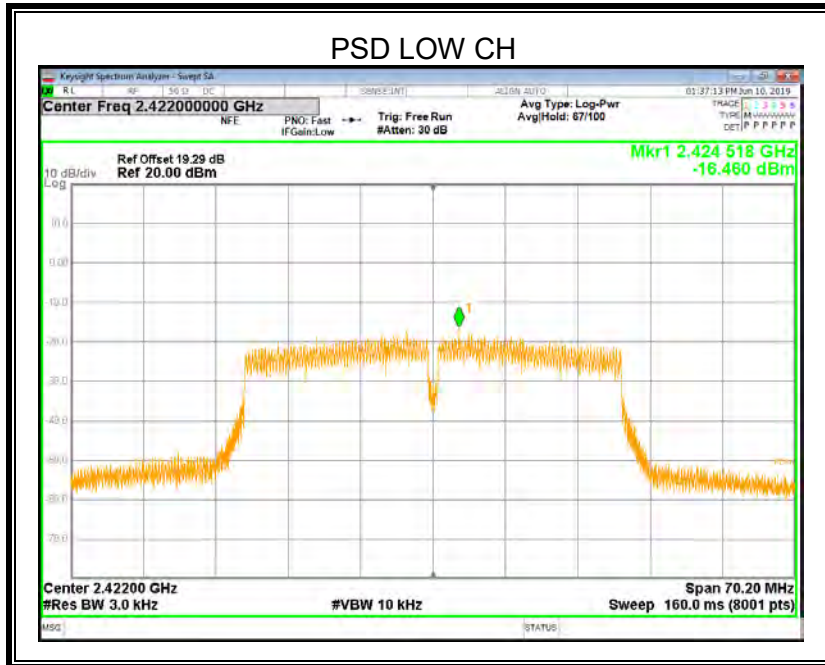

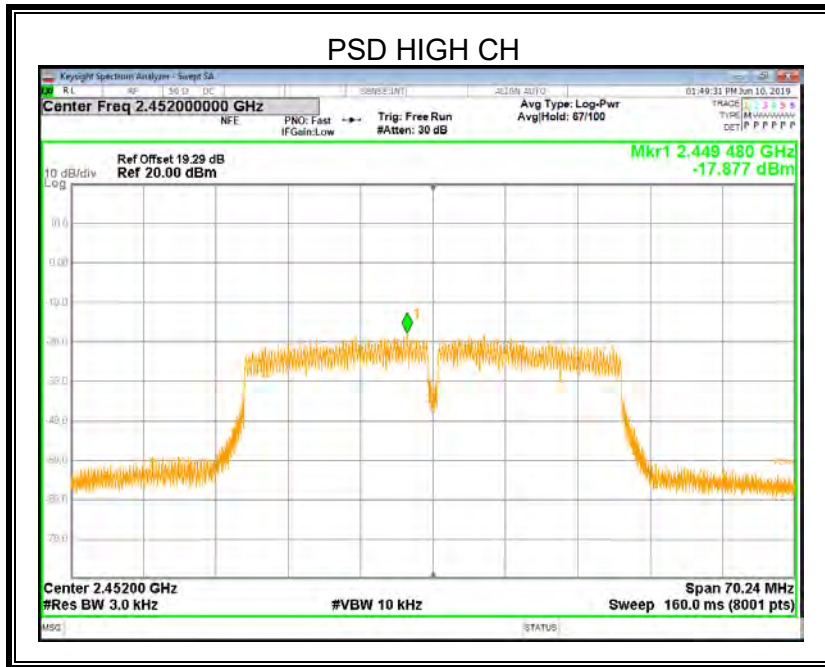

ANTENNA 1

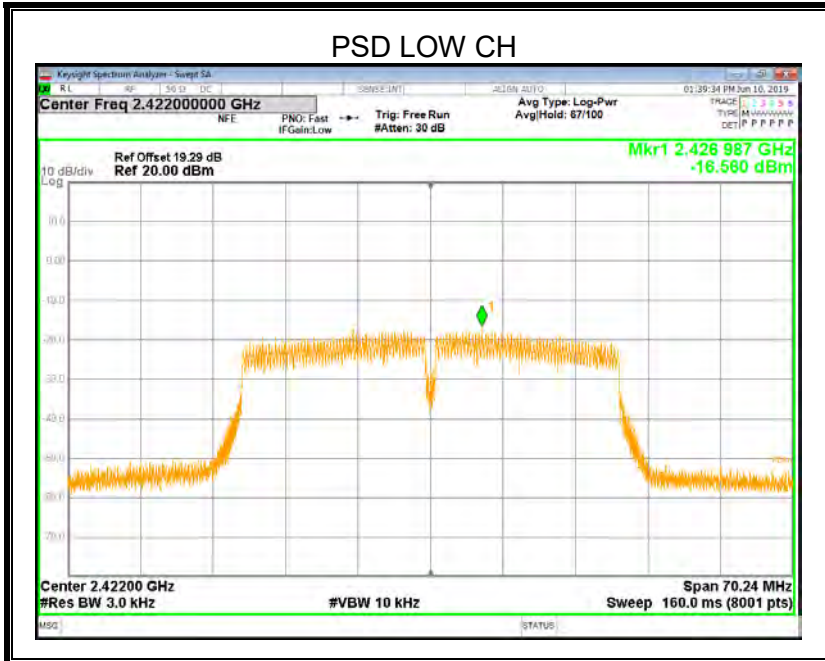

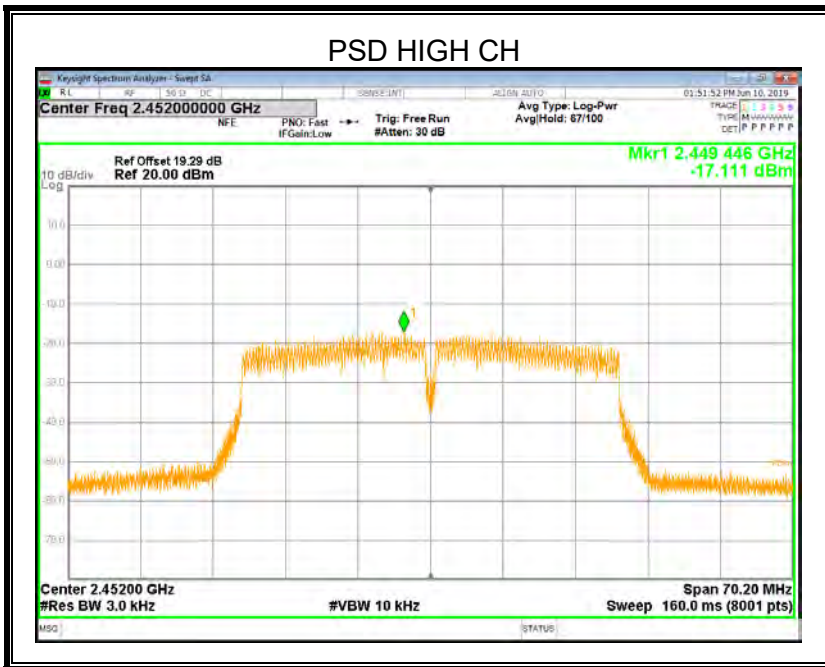
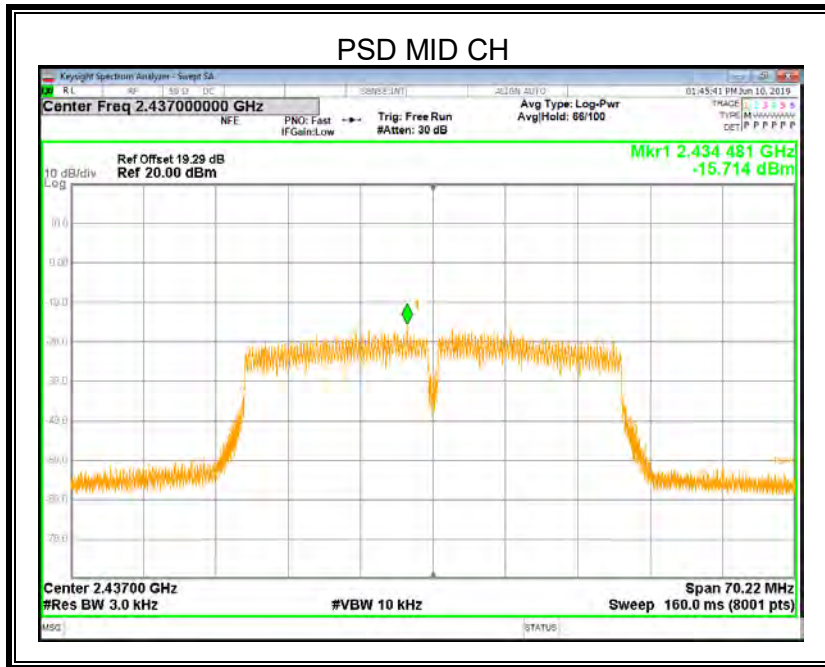



8.5. CONDUCTED BANDEGE AND SPURIOUS EMISSIONS

LIMITS

CFR 47 FCC Part15 (15.247) Subpart C ISED RSS-247 ISSUE 2		
Section	Test Item	Limit
CFR 47 FCC §15.247 (d) ISED RSS-247 5.5	Conducted Bandedge and Spurious Emissions	at least 20 dB below that in the 100 kHz bandwidth within the band that contains the highest level of the desired power

TEST PROCEDURE

Connect the UUT to the spectrum analyser and use the following settings:

Center Frequency	The centre frequency of the channel under test
Detector	Peak
RBW	100K
VBW	$\geq 3 \times \text{RBW}$
Span	1.5 x DTS bandwidth
Trace	Max hold
Sweep time	Auto couple.

Use the peak marker function to determine the maximum PSD level.

Span	Set the center frequency and span to encompass frequency range to be measured
Detector	Peak
RBW	100K
VBW	$\geq 3 \times \text{RBW}$
measurement points	$\geq \text{span}/\text{RBW}$
Trace	Max hold
Sweep time	Auto couple.

Use the peak marker function to determine the maximum amplitude level.



TEST SETUP

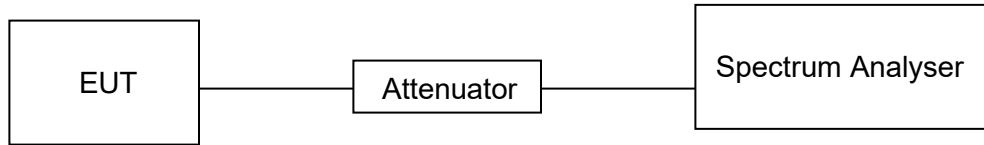

TEST ENVIRONMENT

Temperature	23.2°C	Relative Humidity	56%
Atmosphere Pressure	101kPa	Test Voltage	DC 3.3V

RESULTS



8.5.1. 802.11b SISO MODE

ANTENNA 1

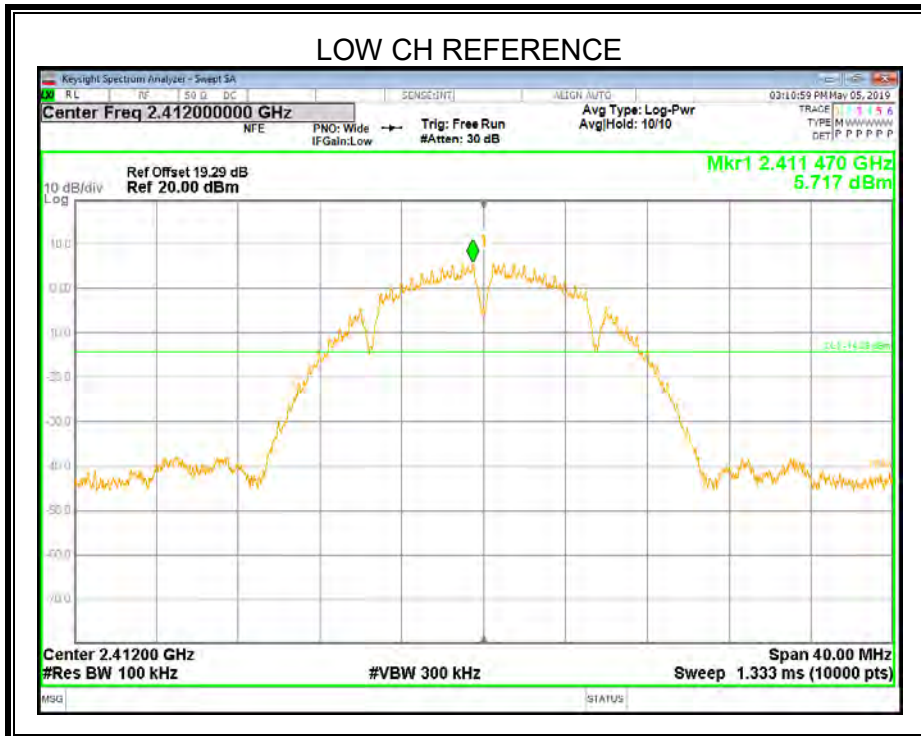
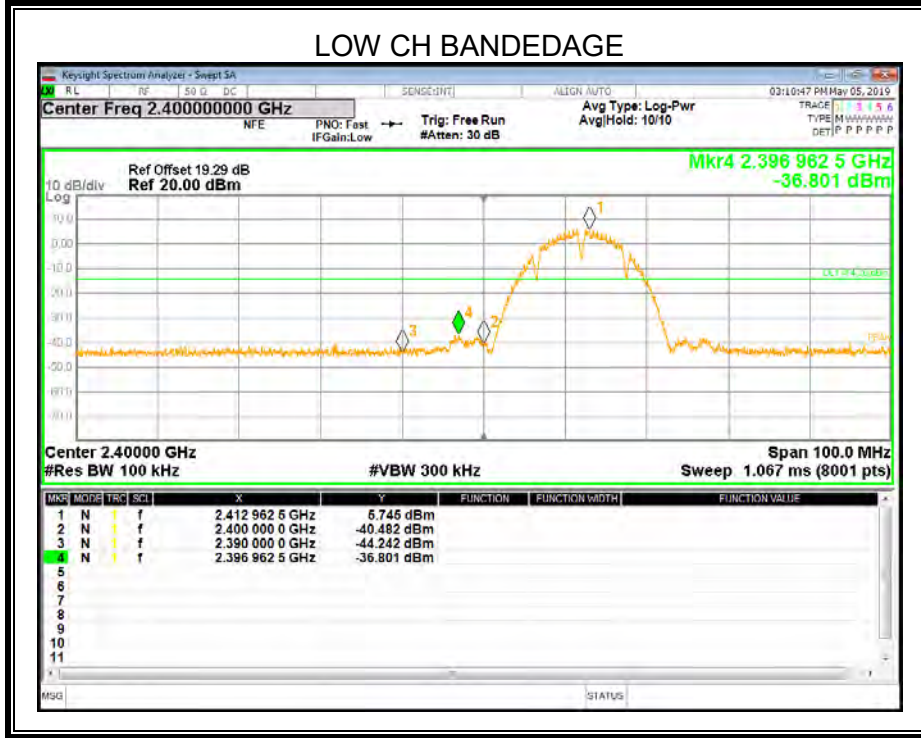

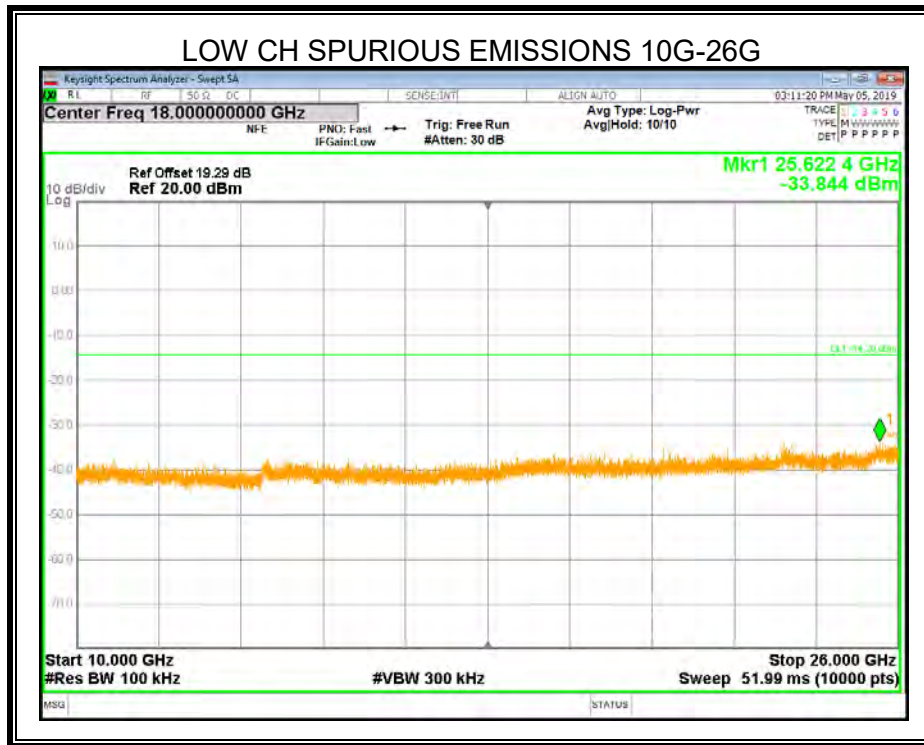
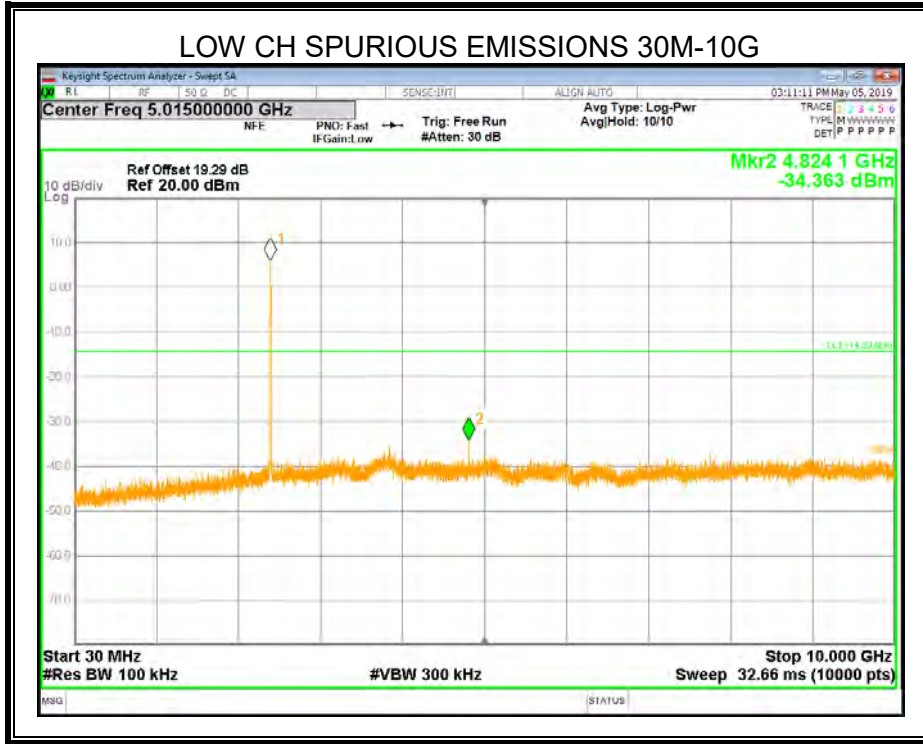

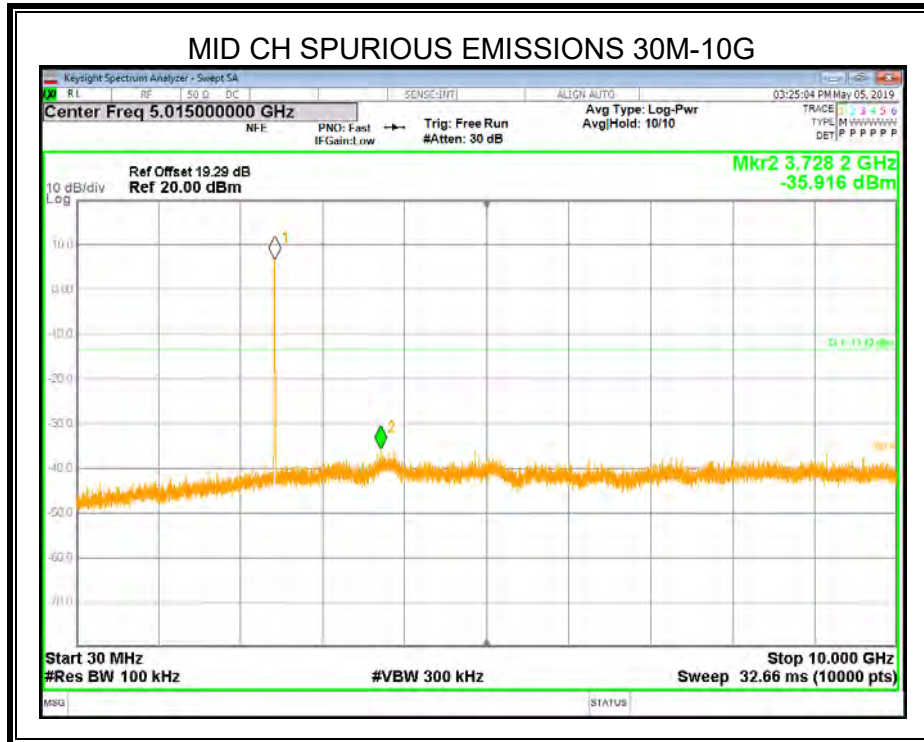
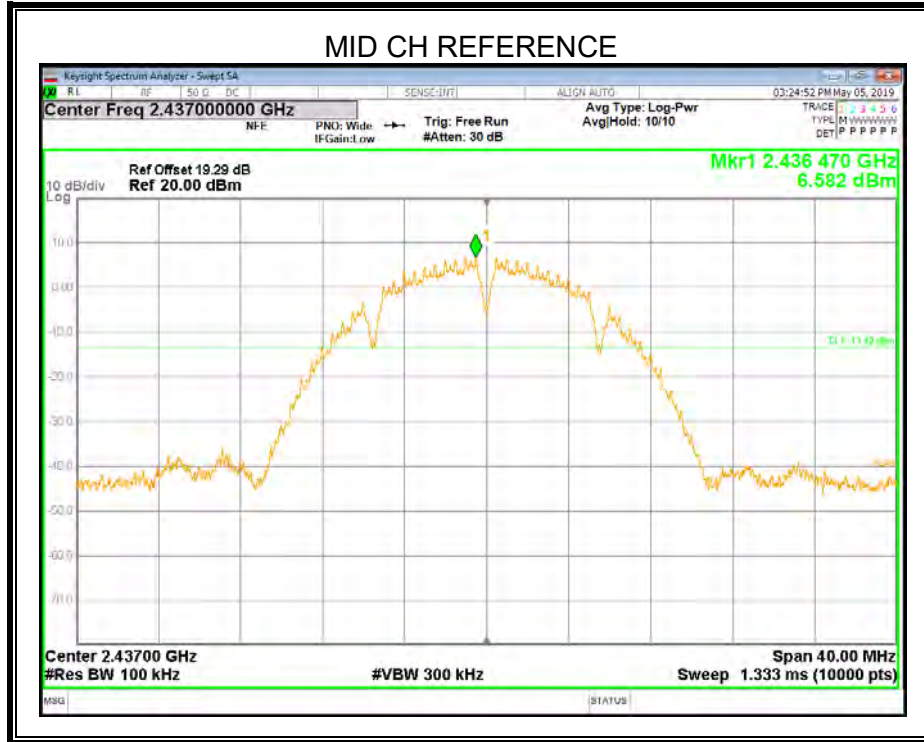

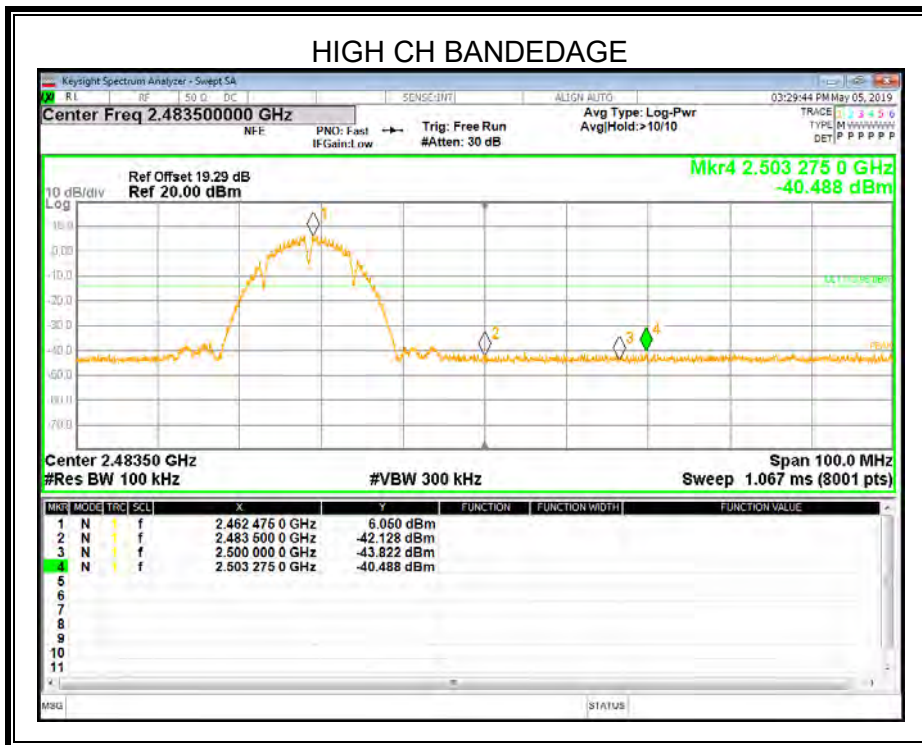
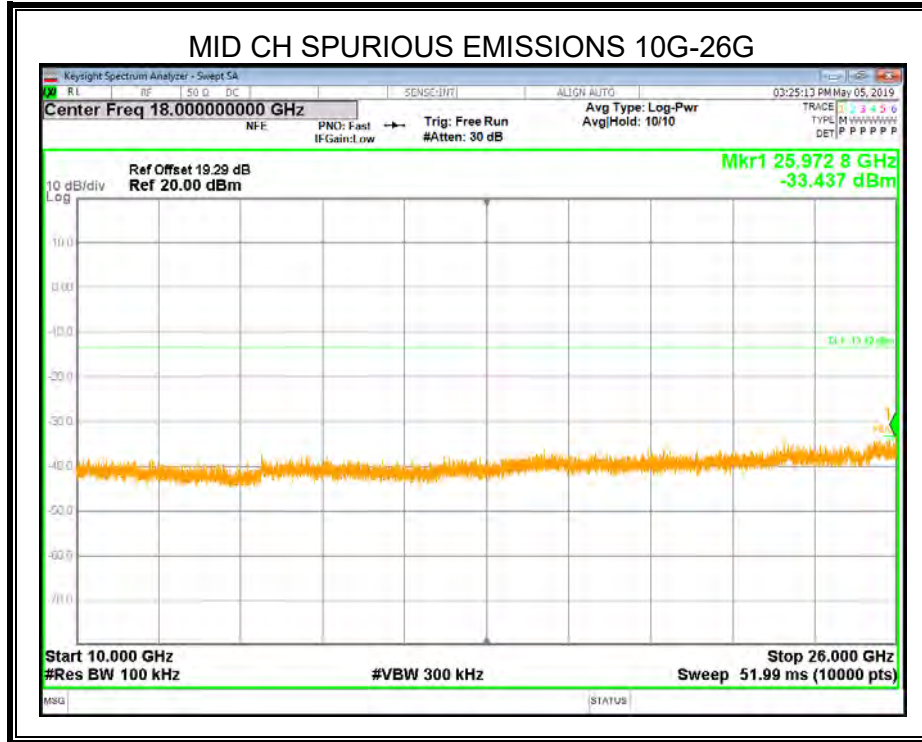

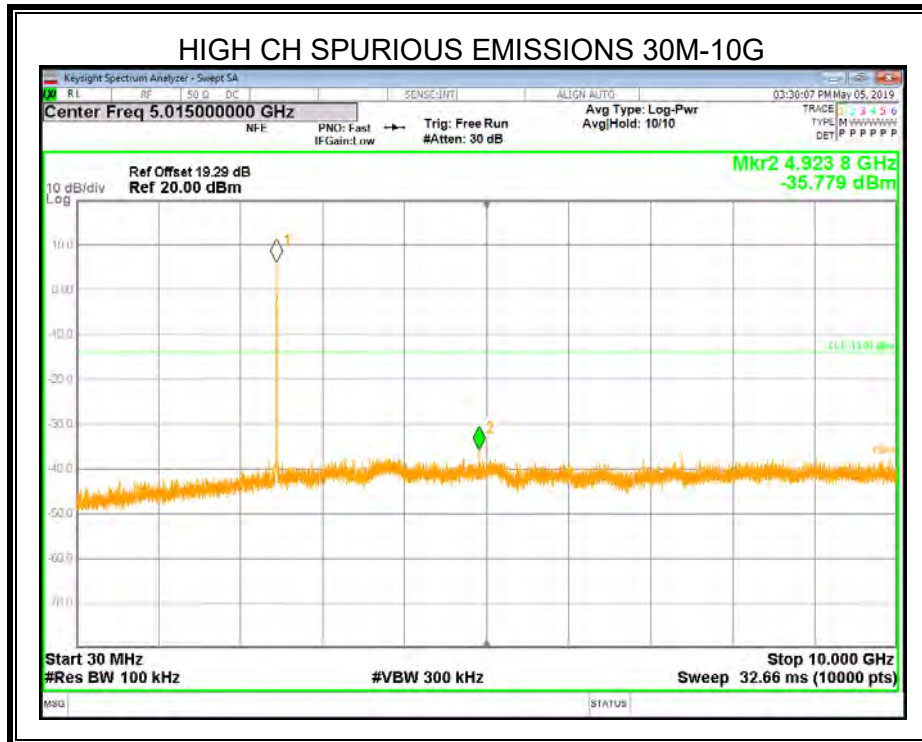
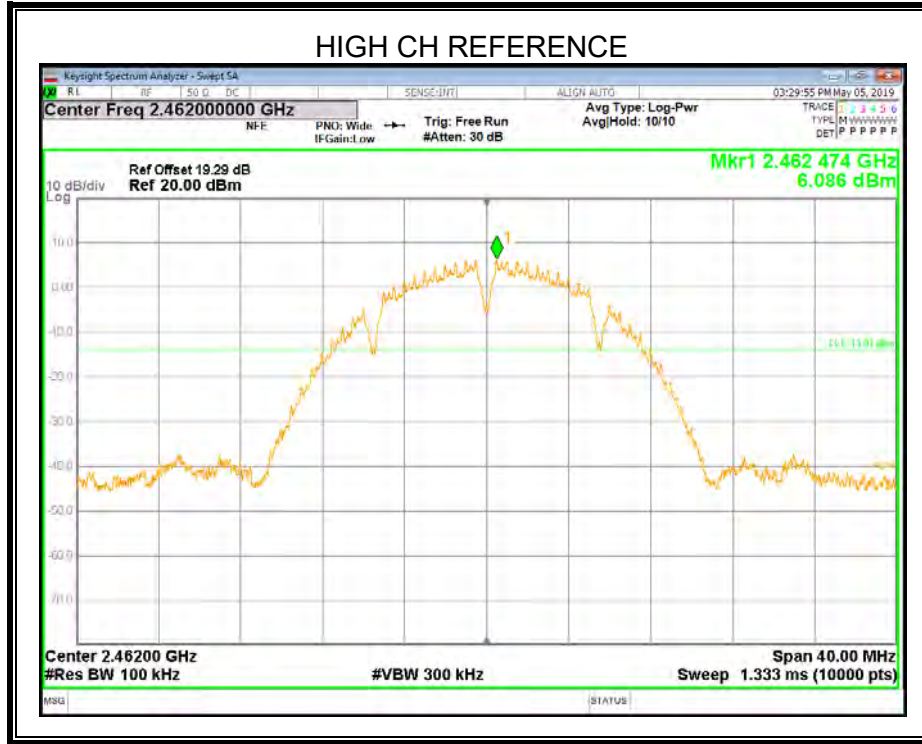

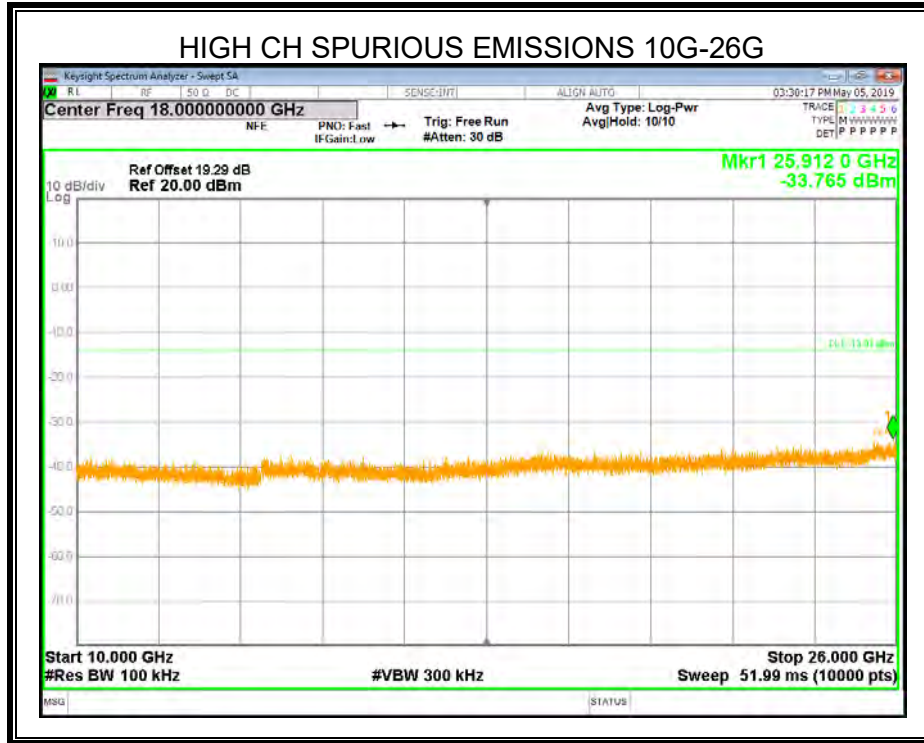

Note: All the modes and antenna ports had been tested, only the worst data recorded in the report.



8.5.2. 802.11g SISO MODE

ANTENNA 1

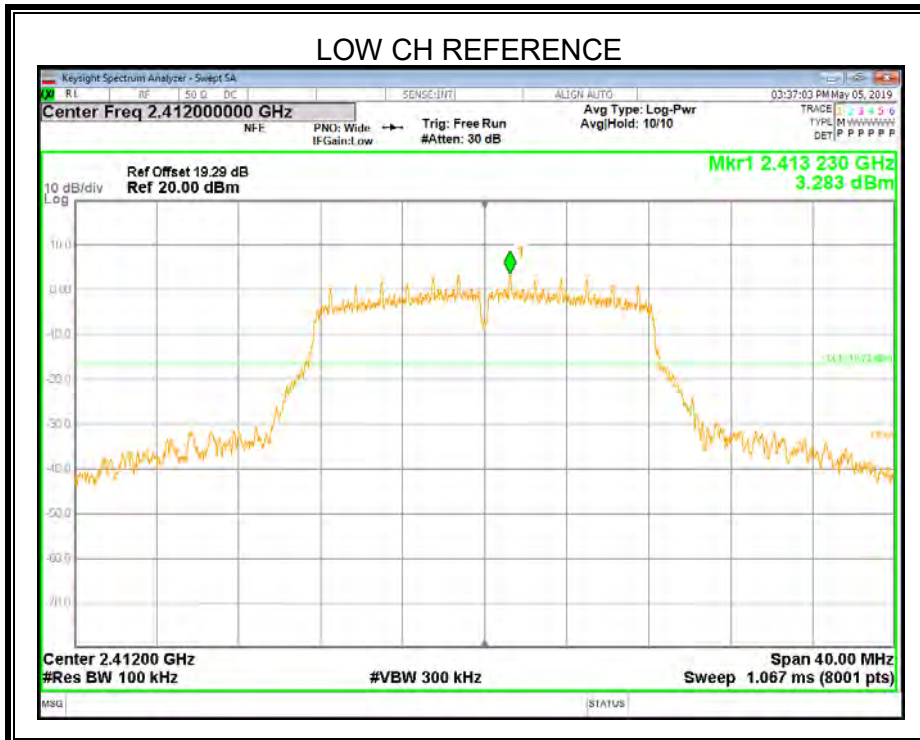
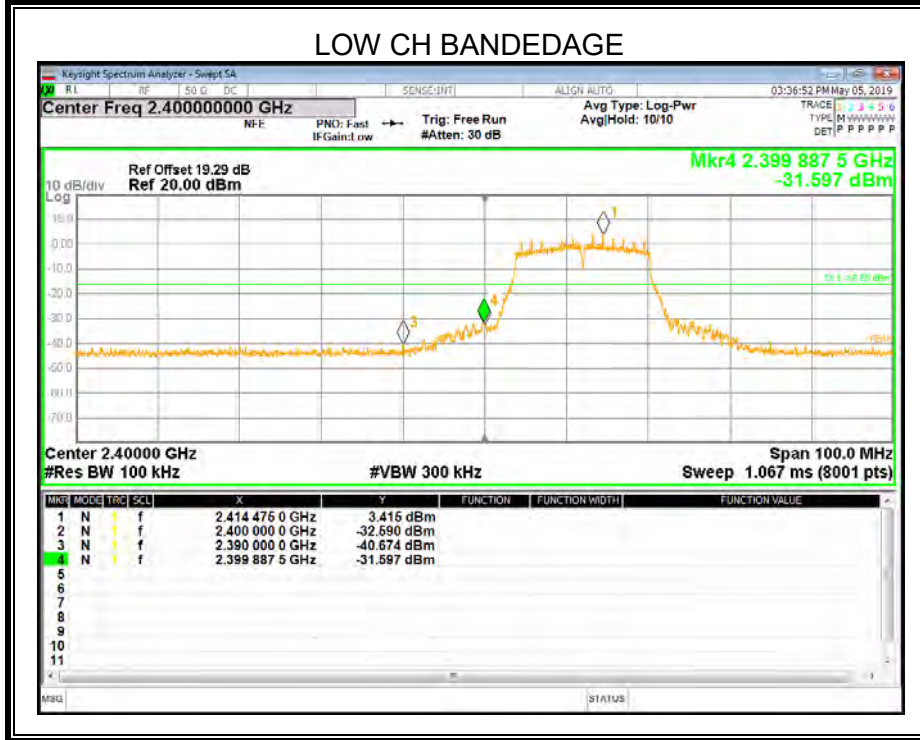

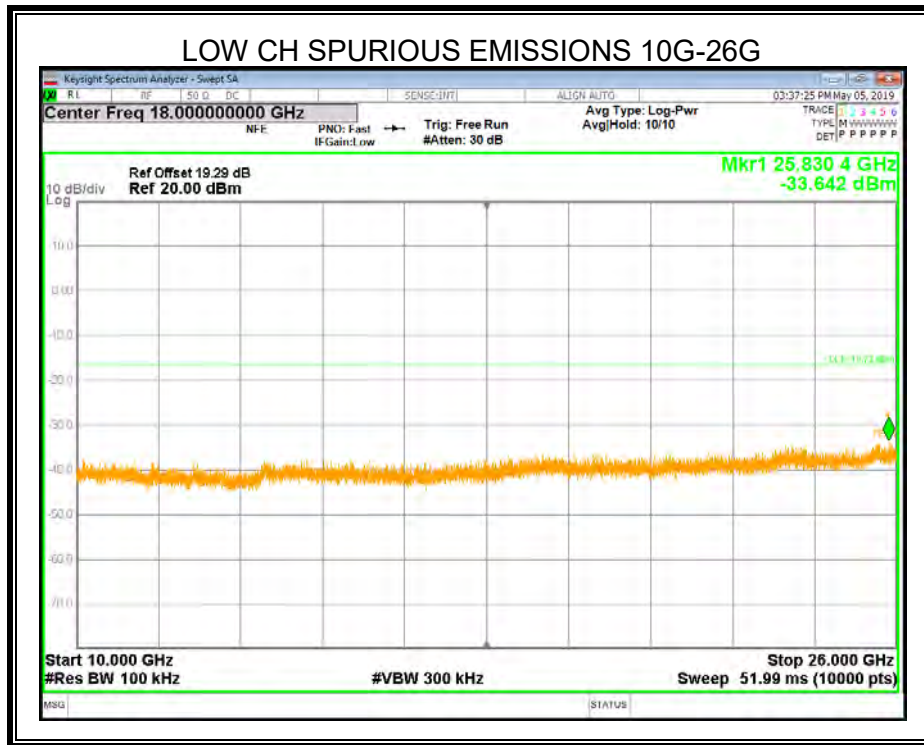
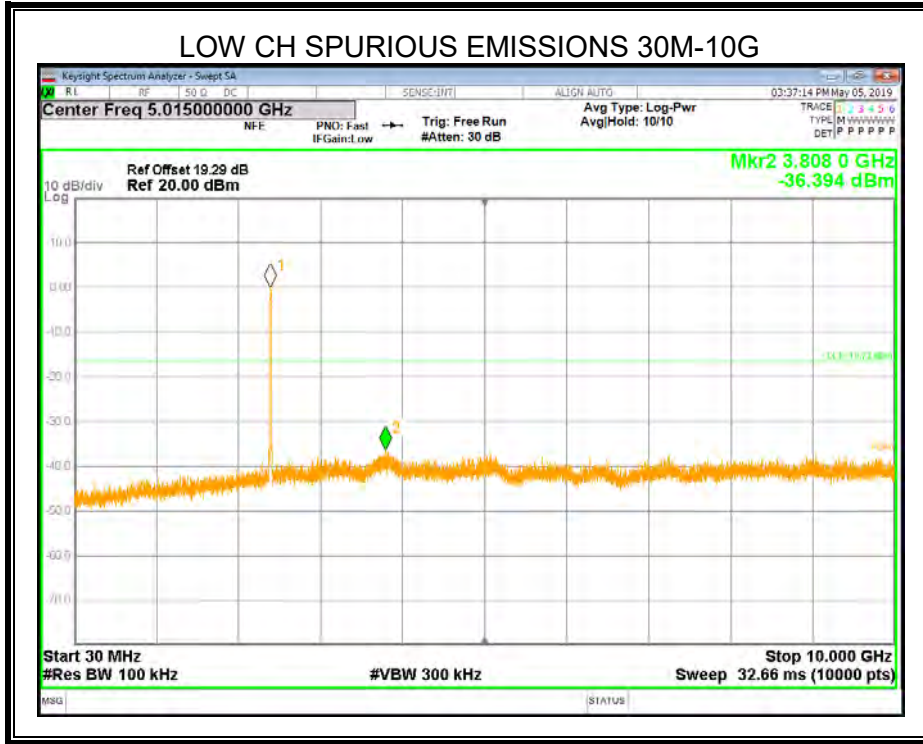

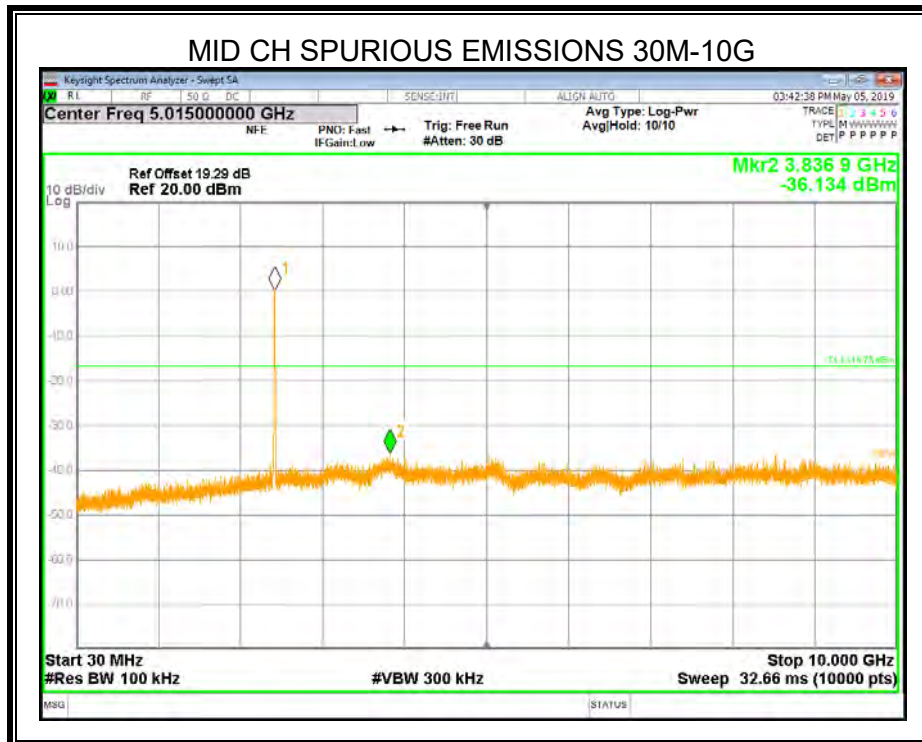
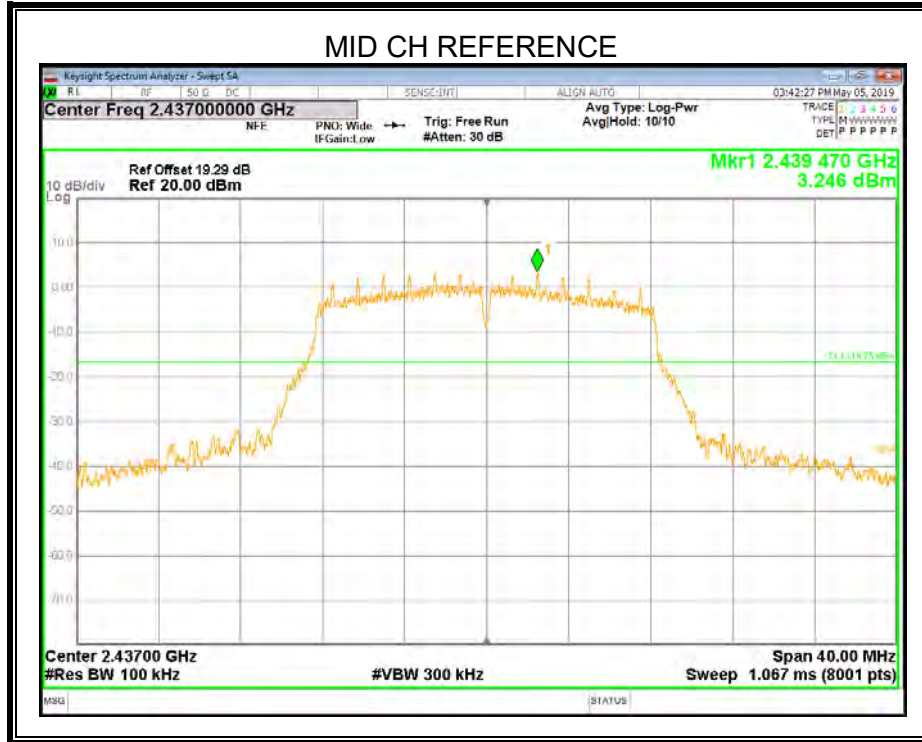

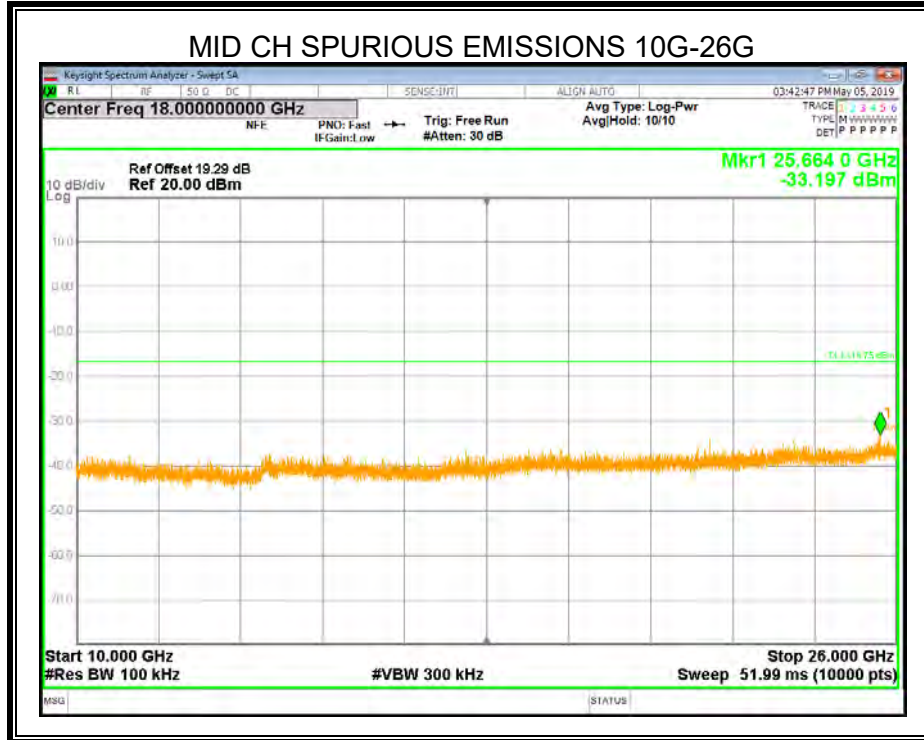

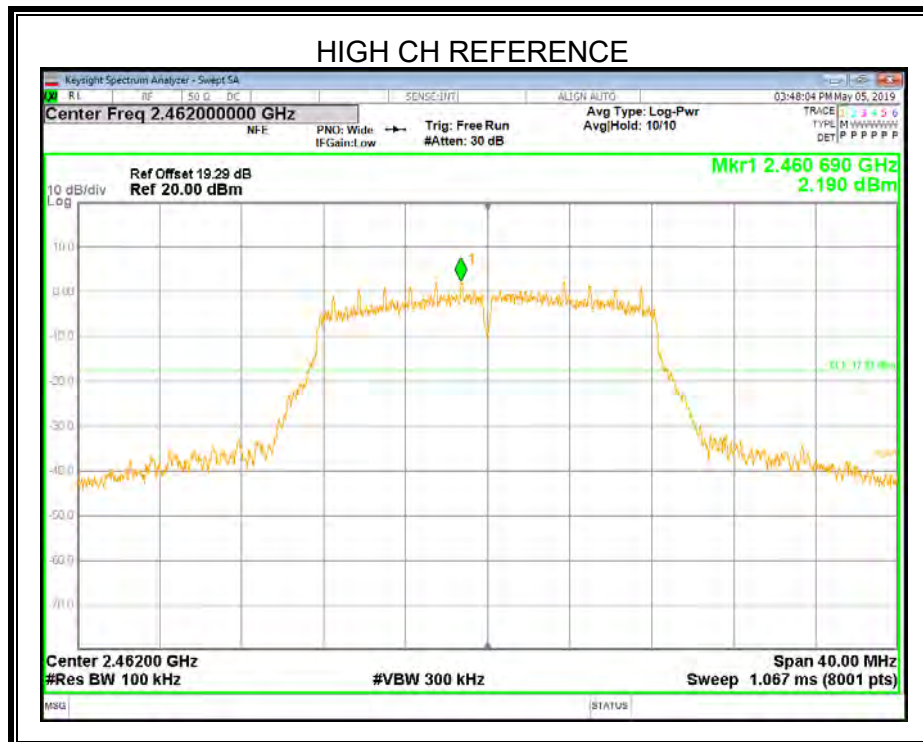
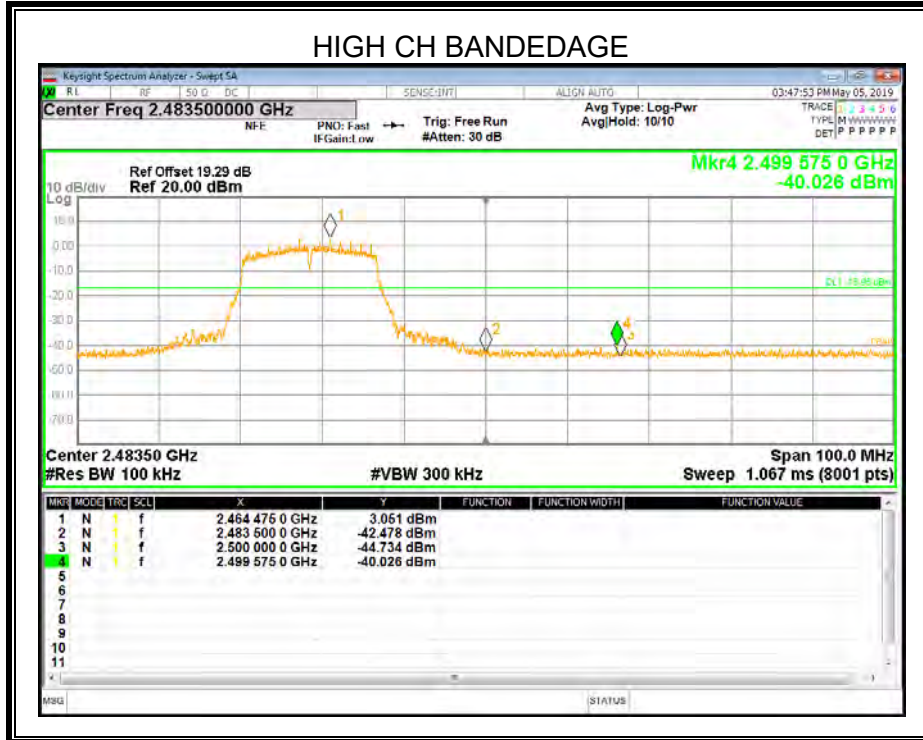

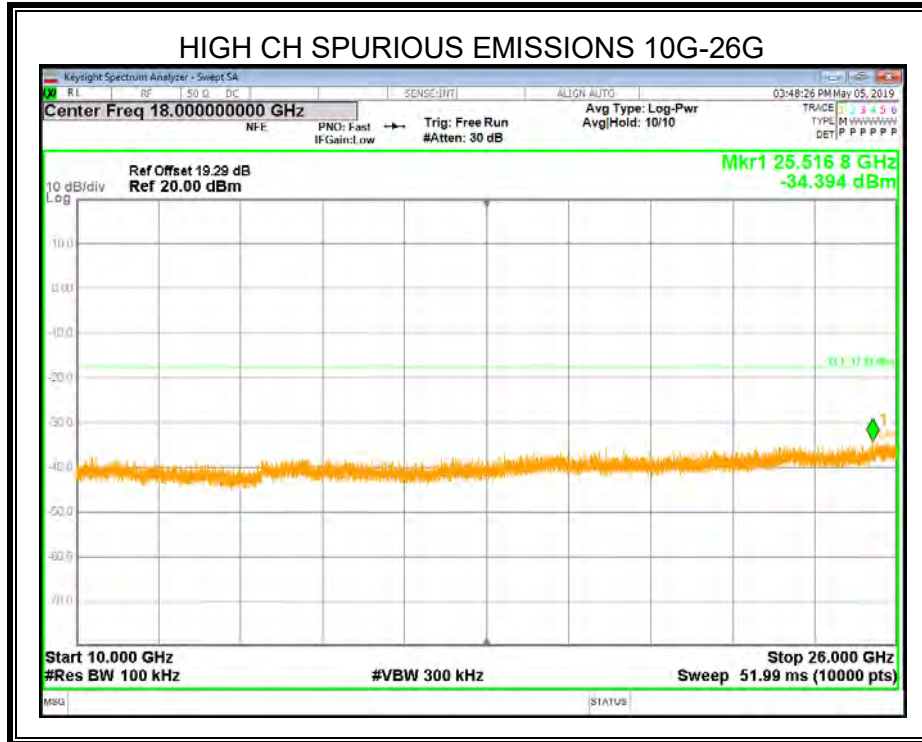
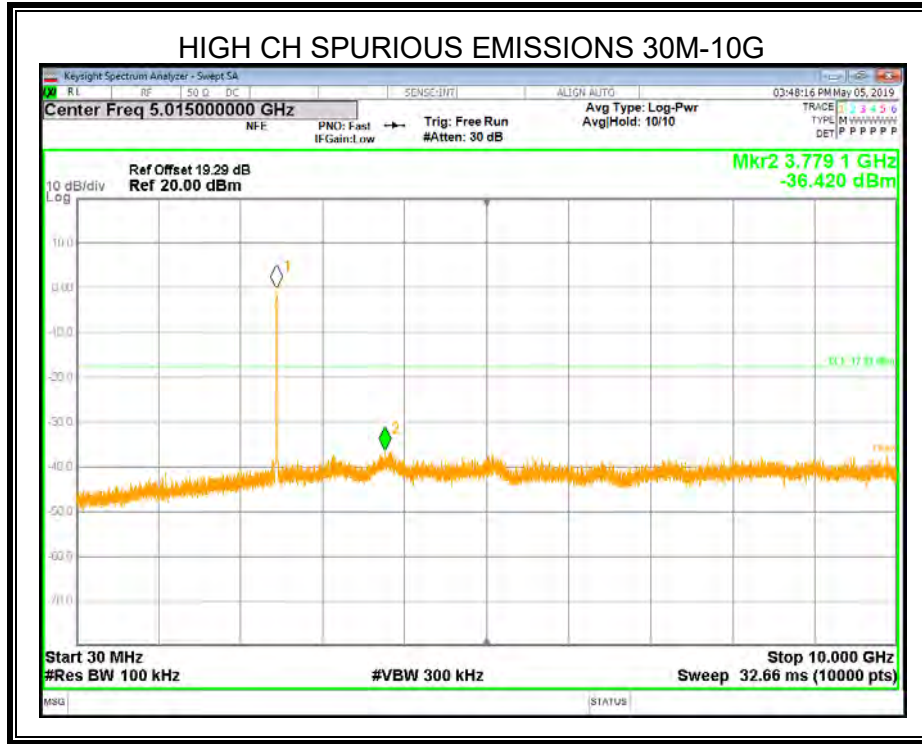

Note: All the modes and antenna ports had been tested, only the worst data recorded in the report.

8.5.3. 802.11n HT20 MIMO MODE

MIMO MODE-2TX

ANTENNA 0

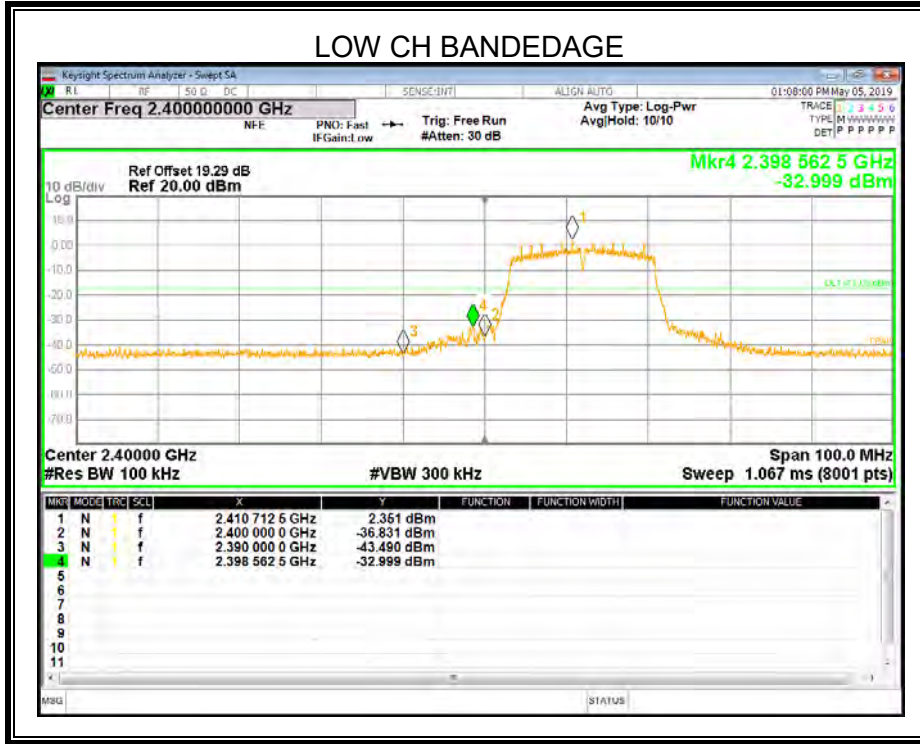

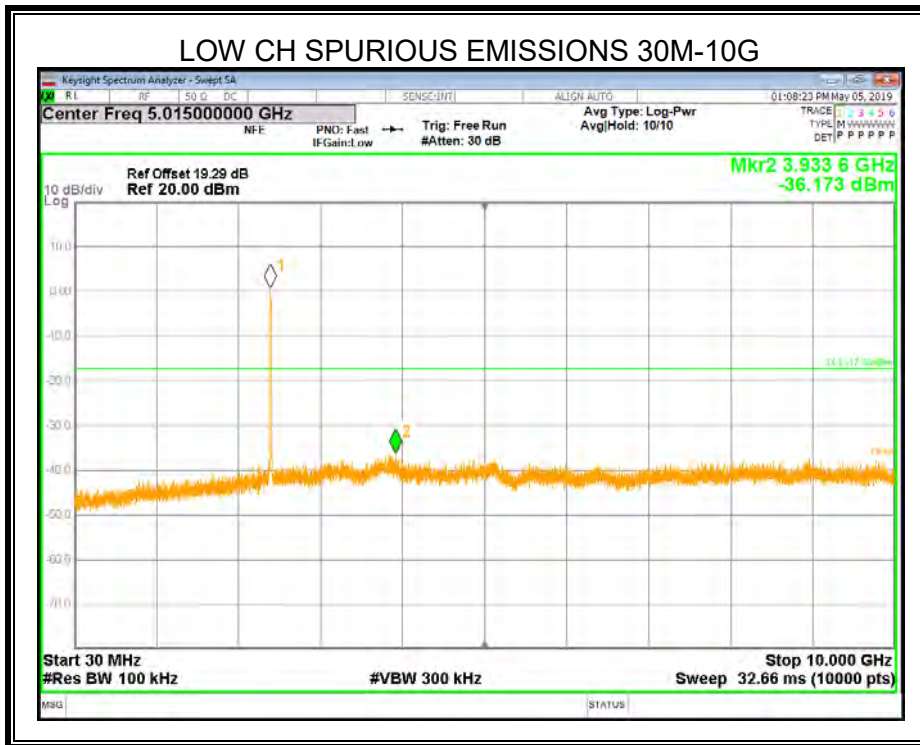
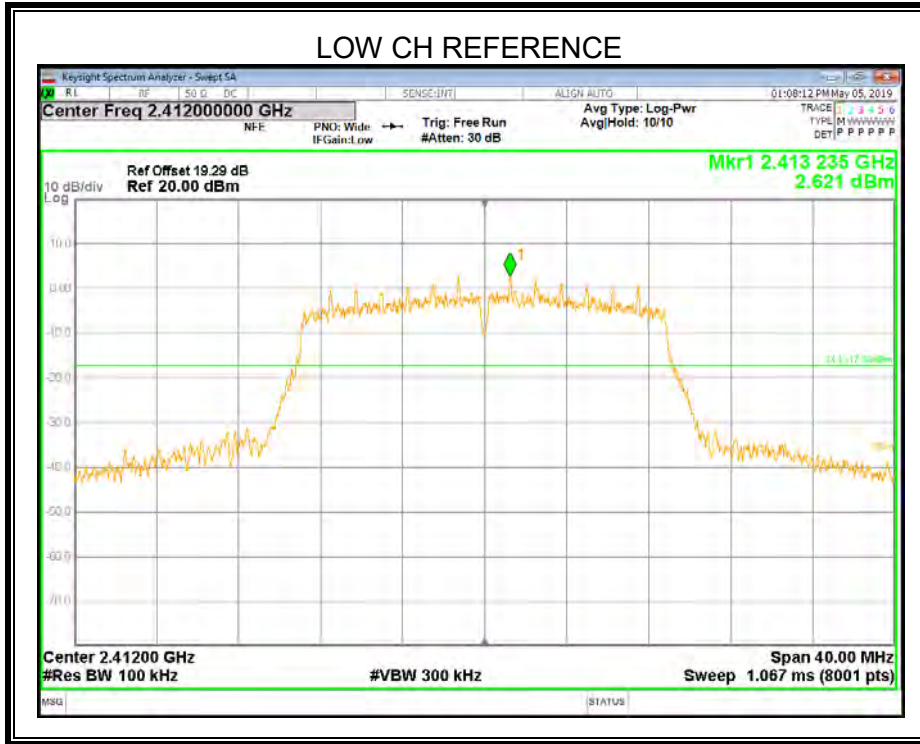

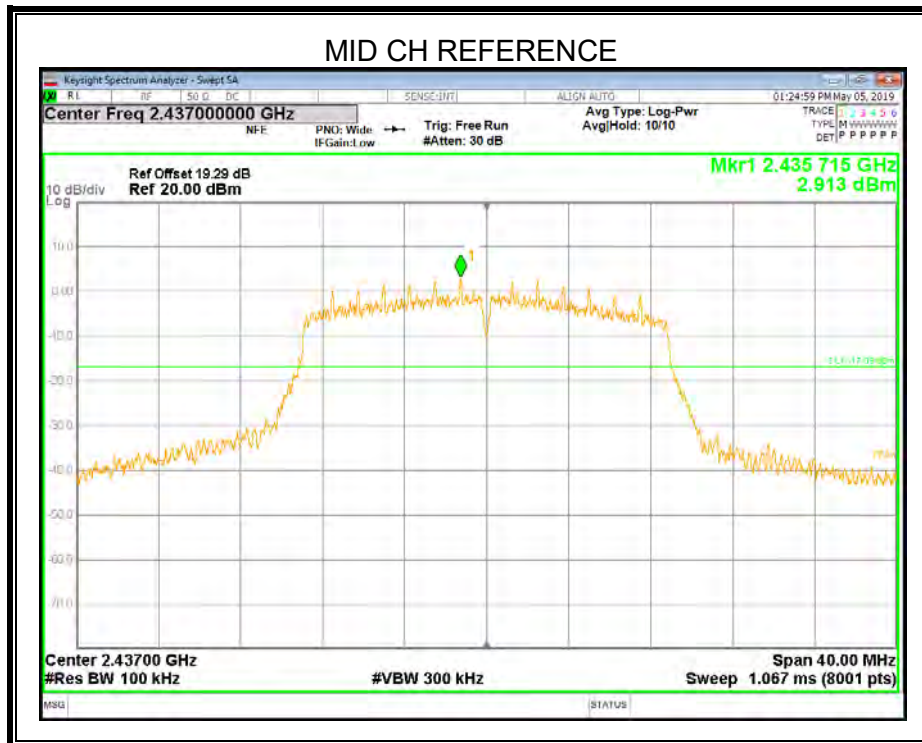
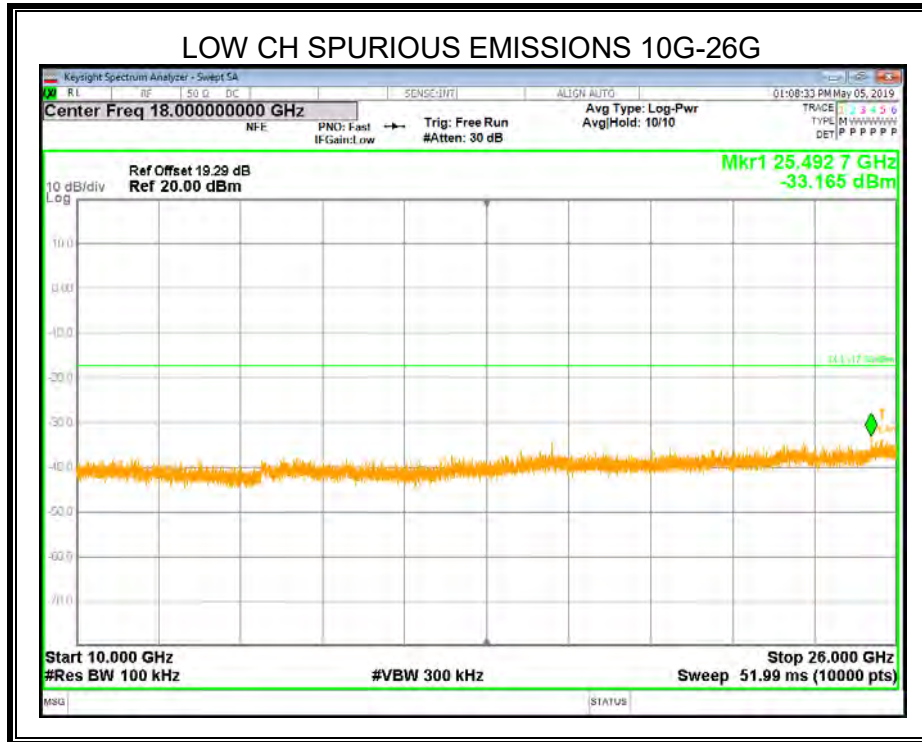

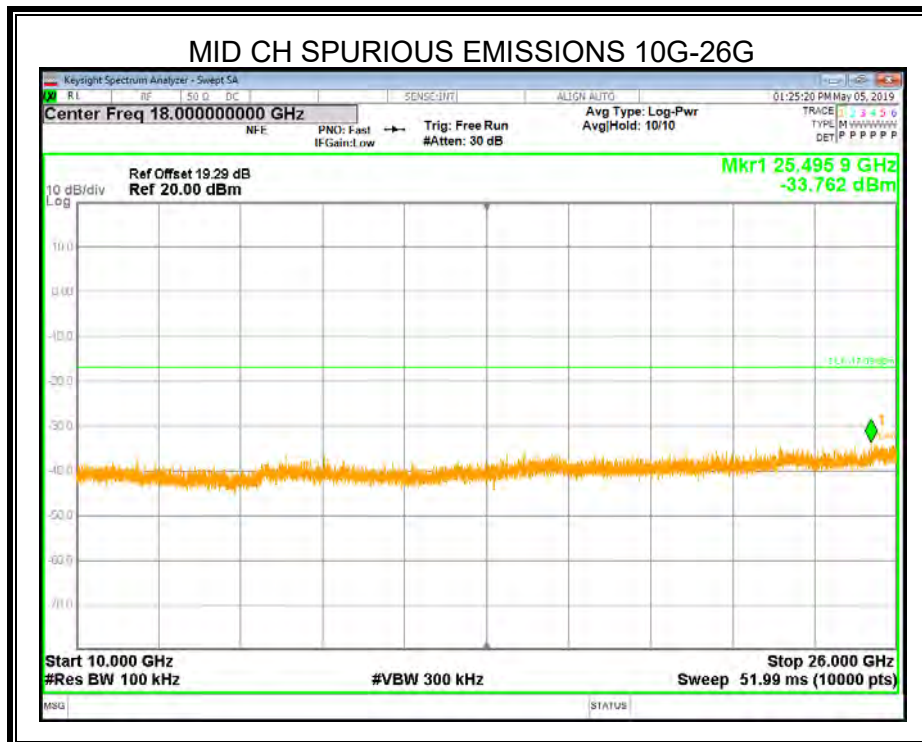
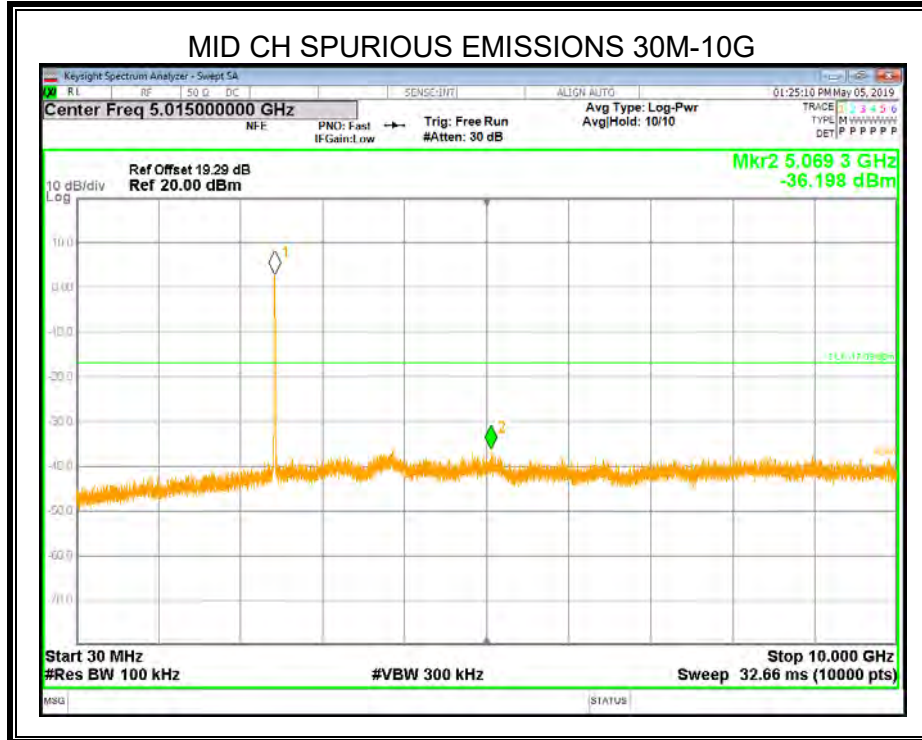

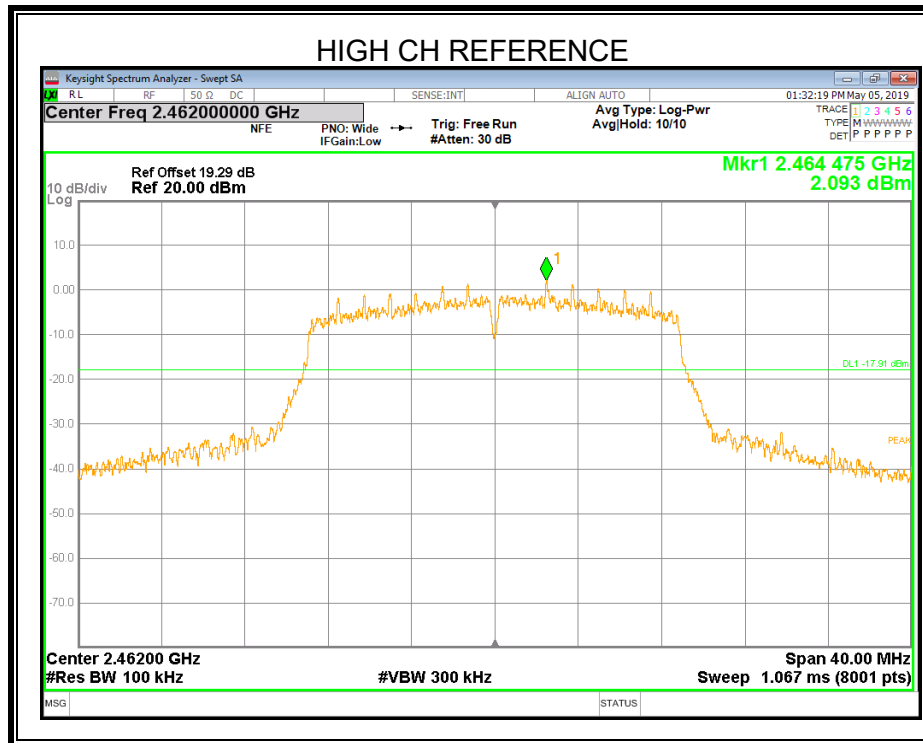
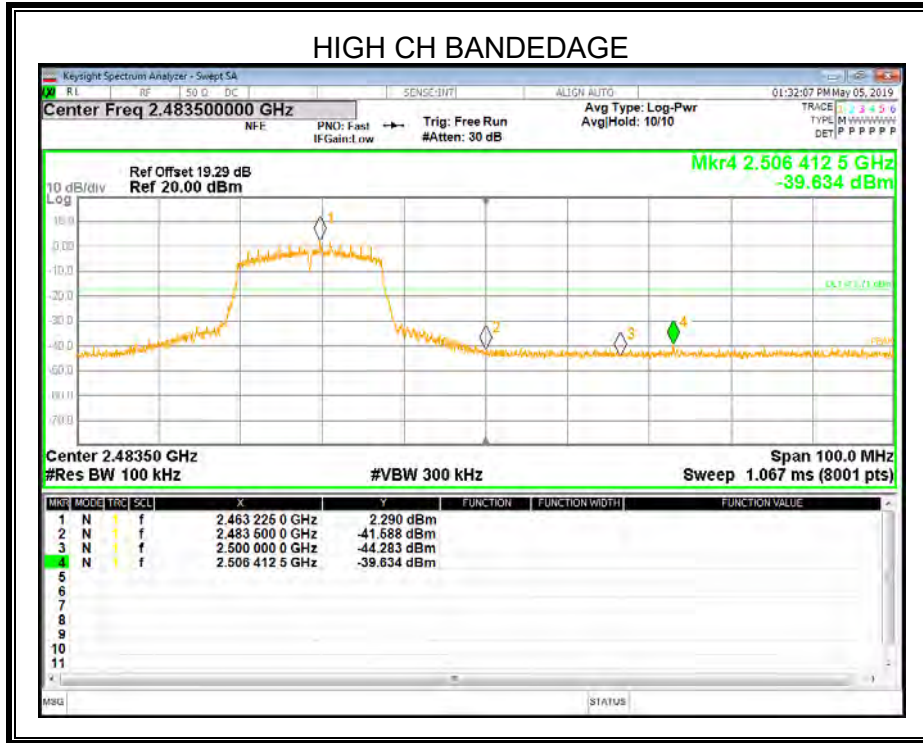

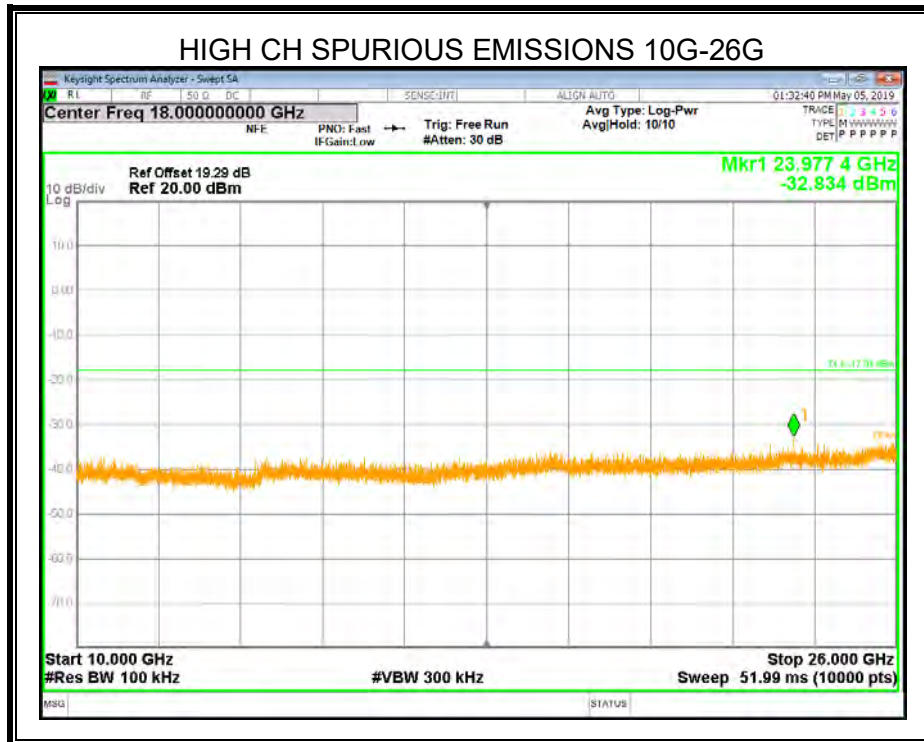
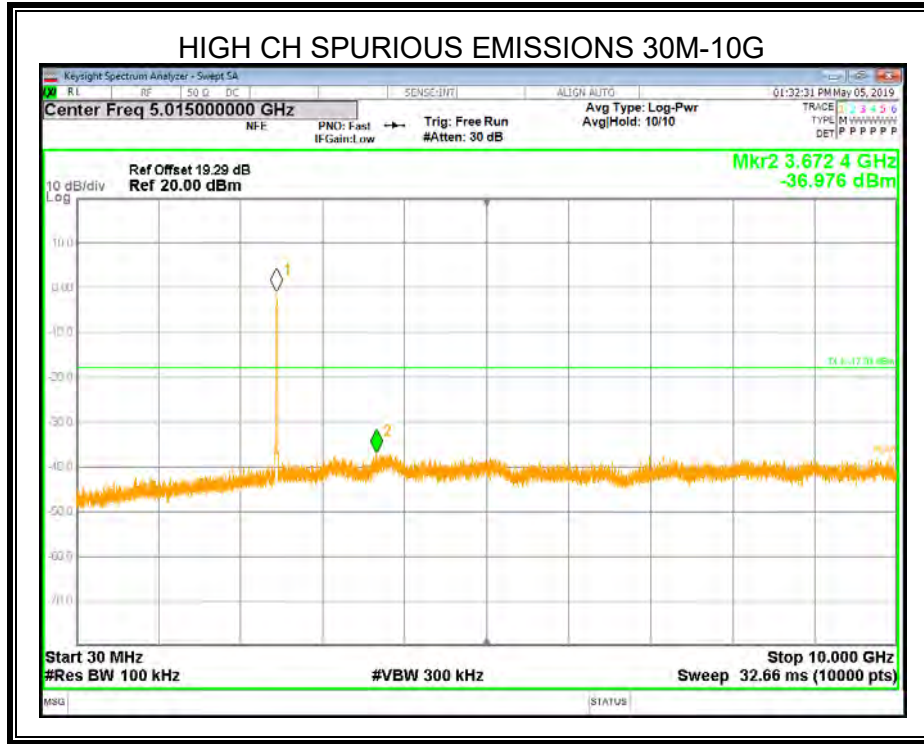



ANTENNA 1

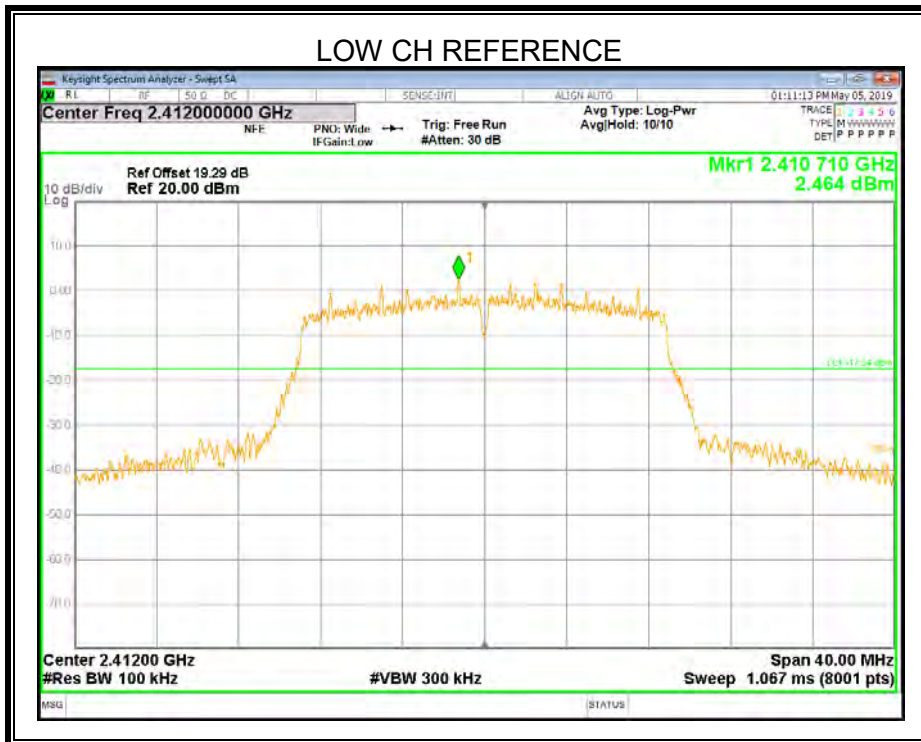
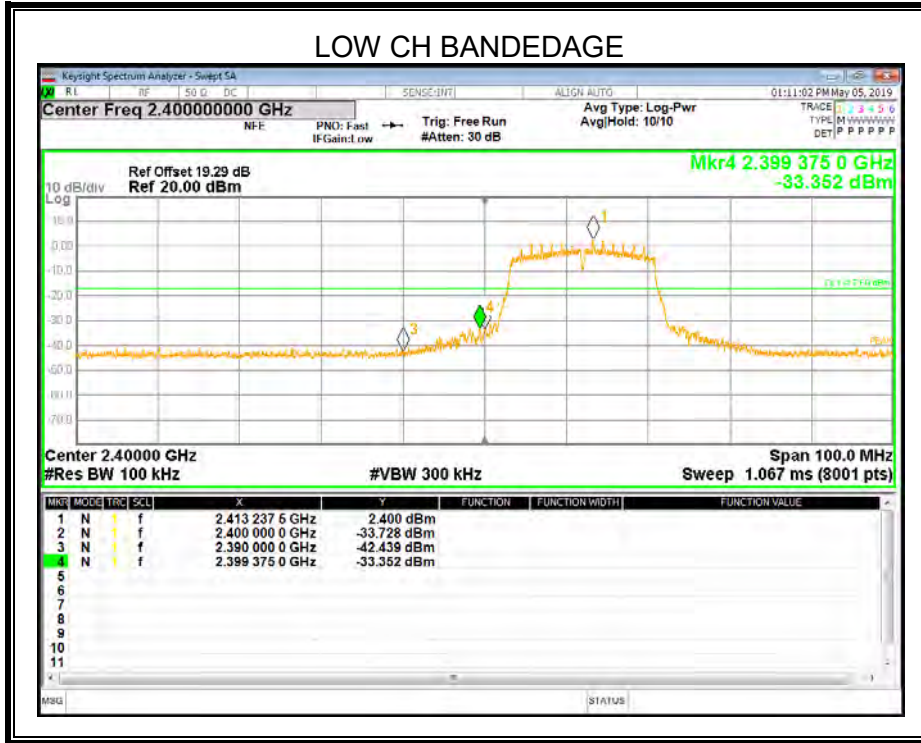

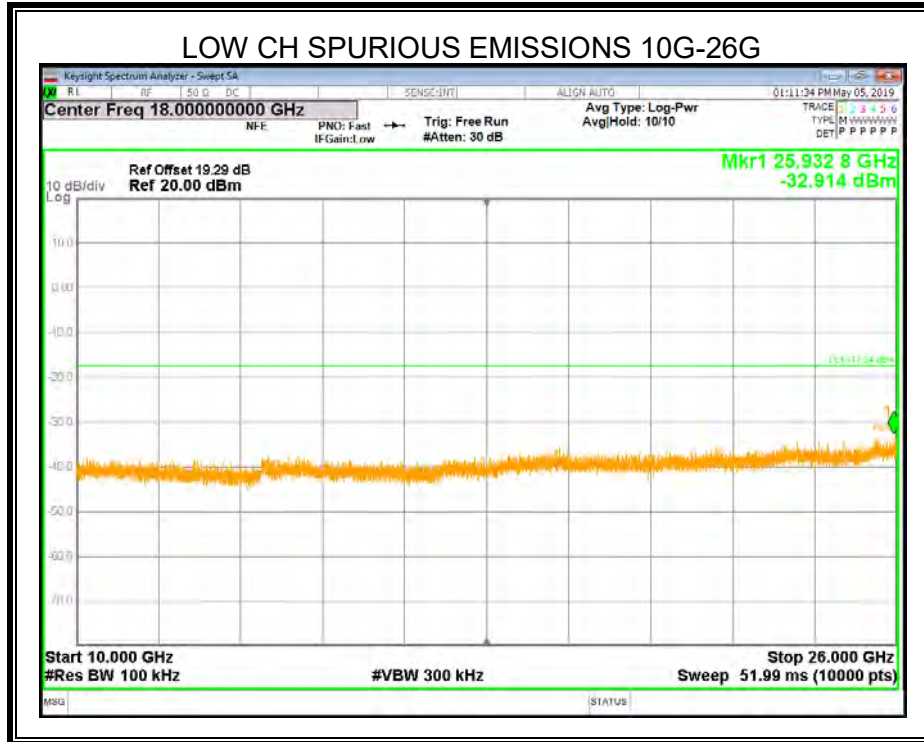
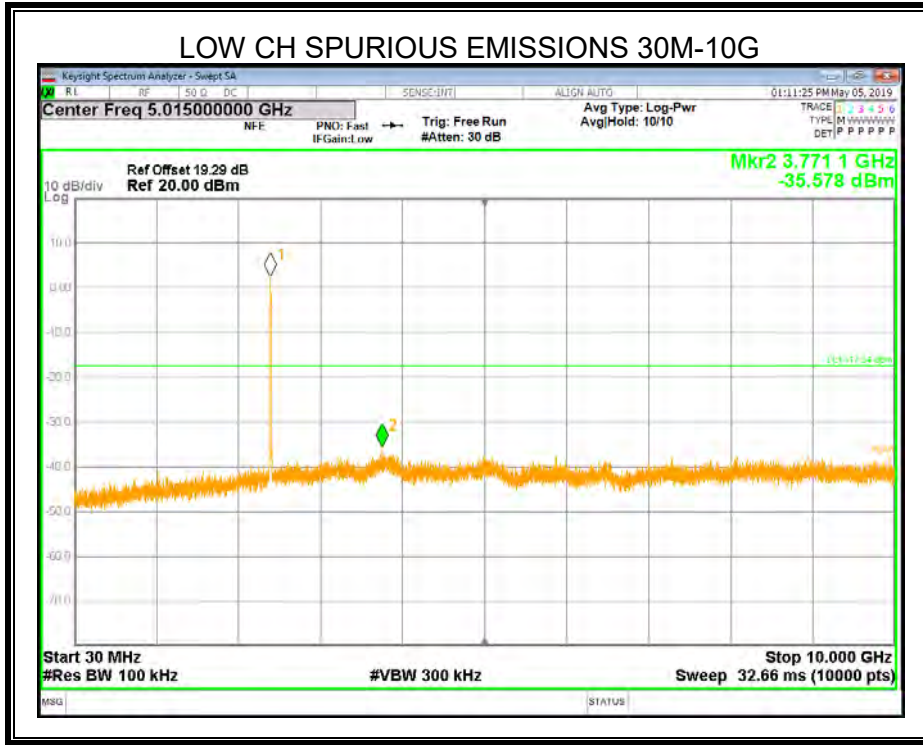

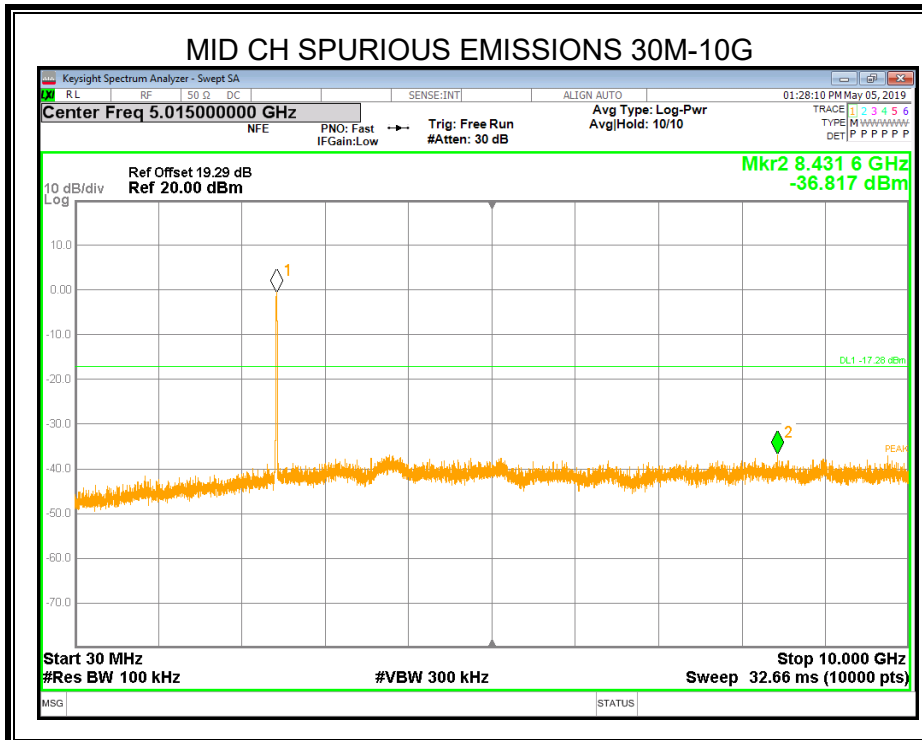
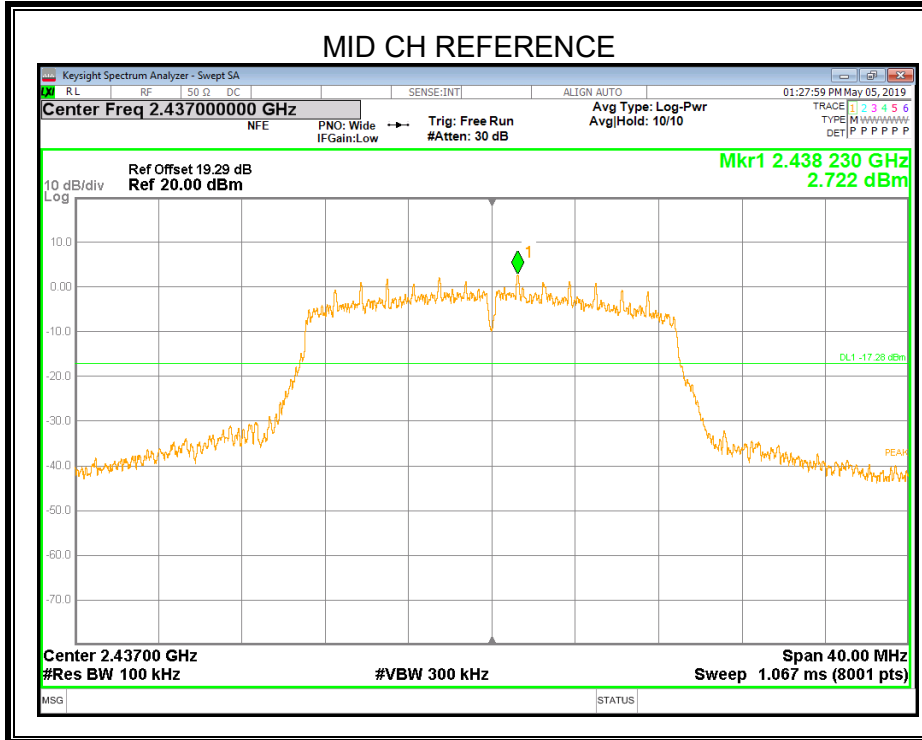

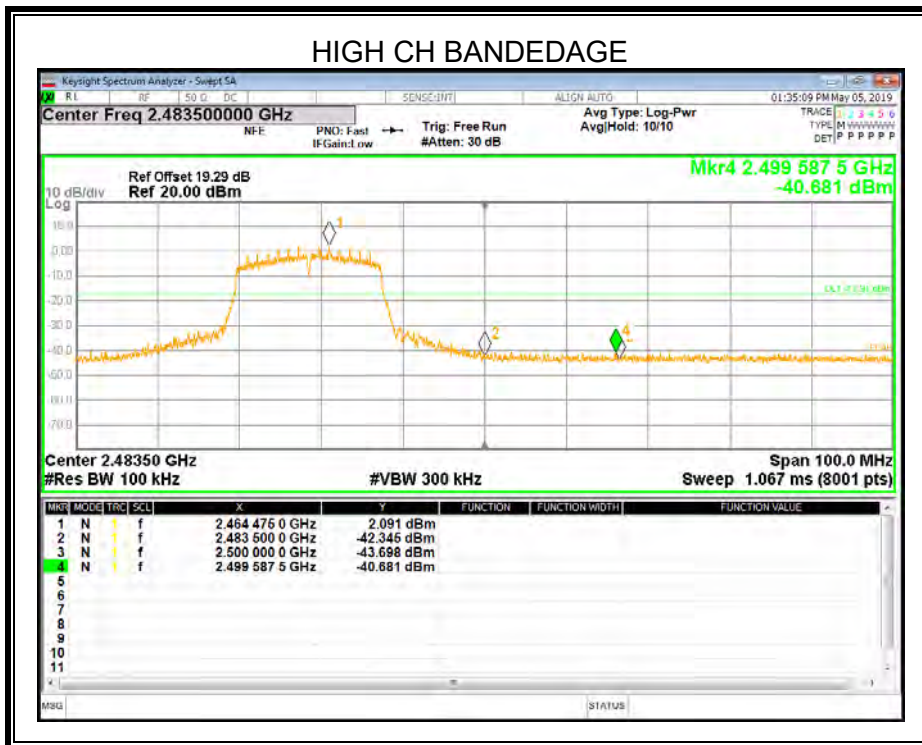
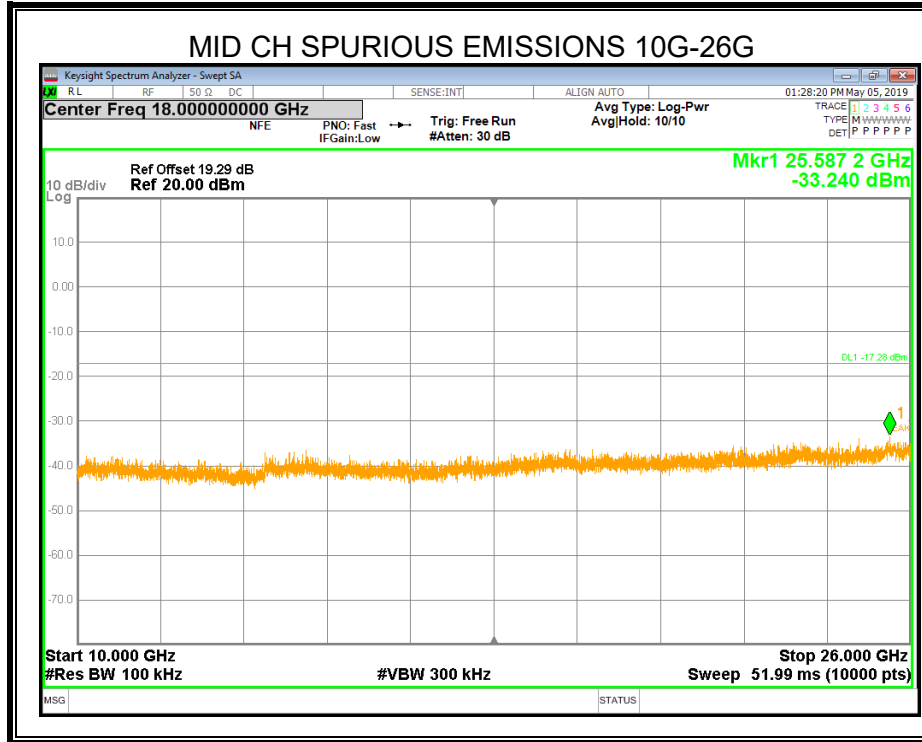

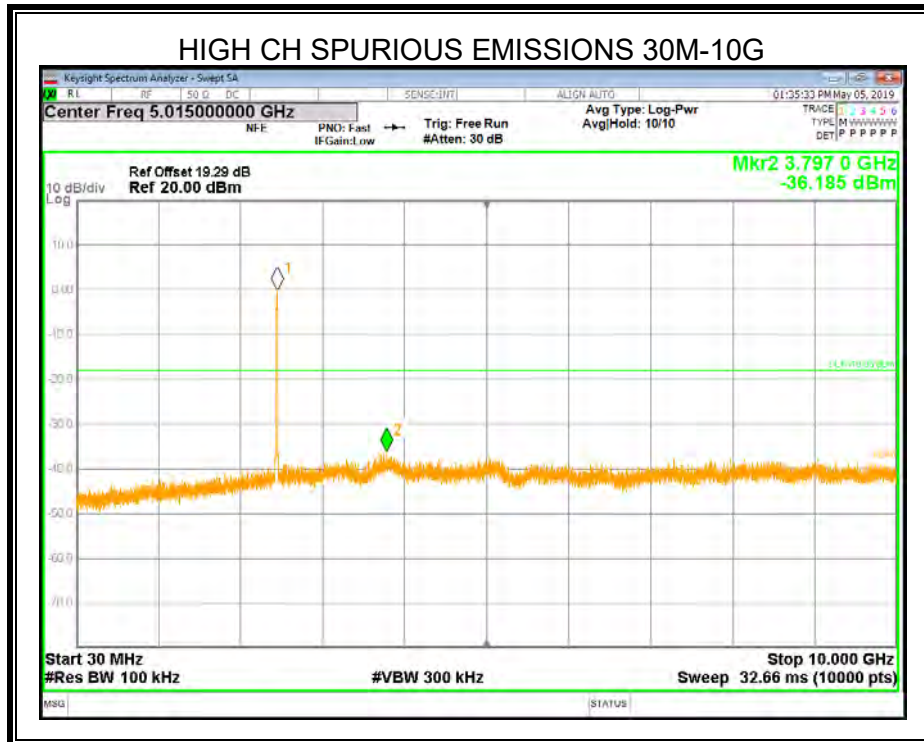
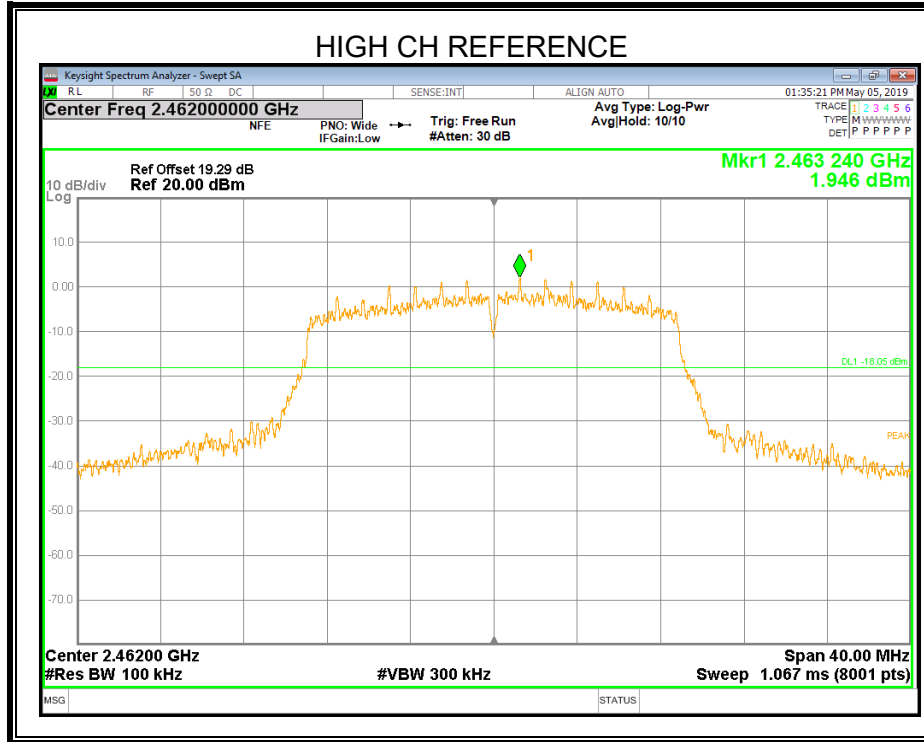

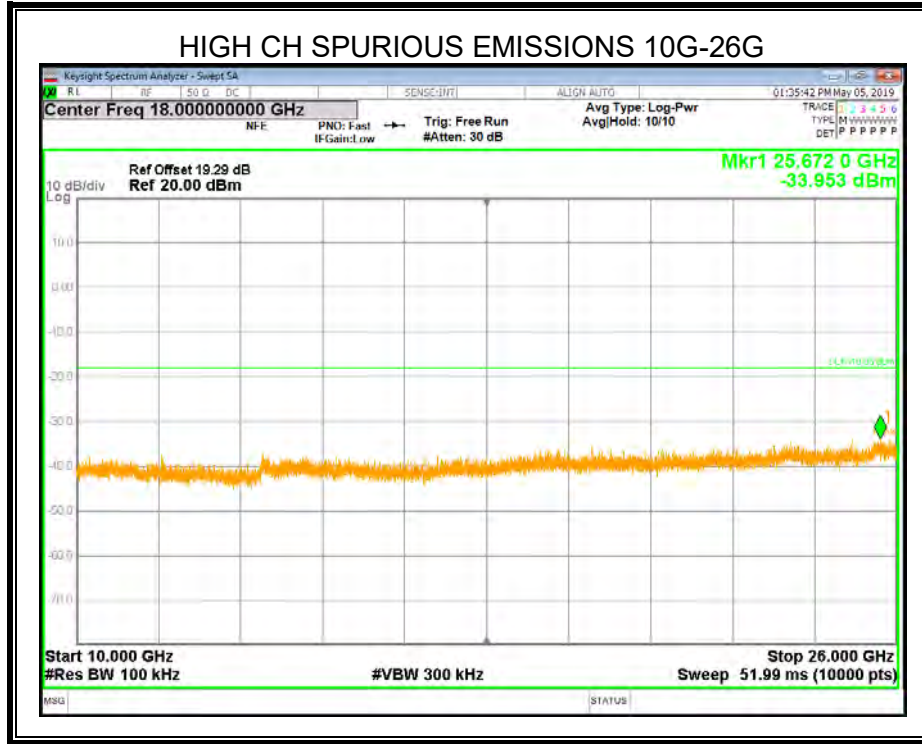



8.5.4. 802.11n HT40 MIM MODE

MIMO MODE-2TX

ANTENNA 0

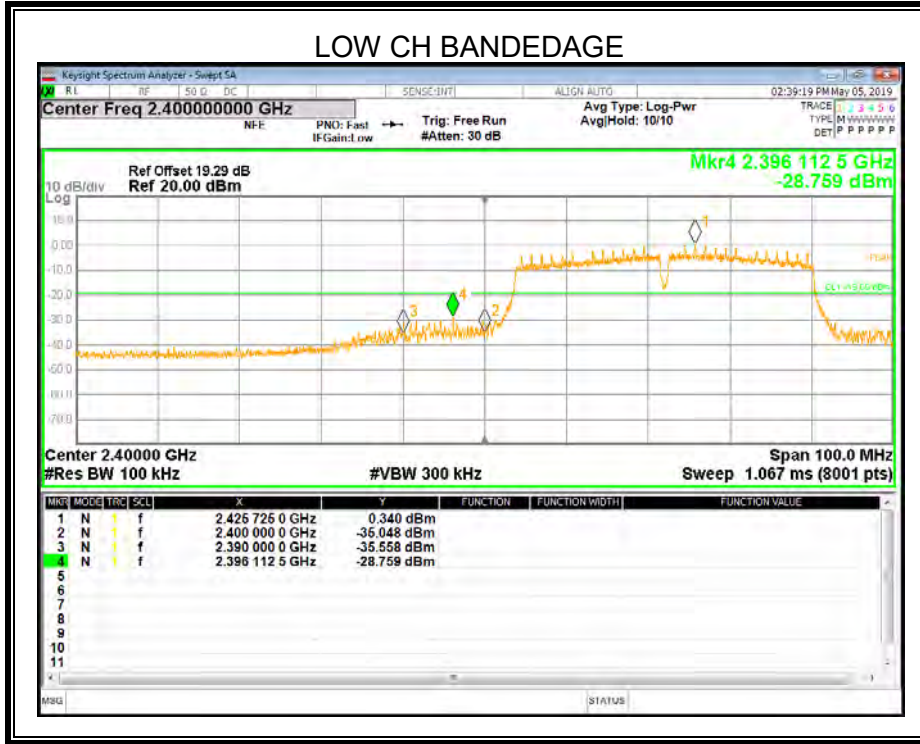

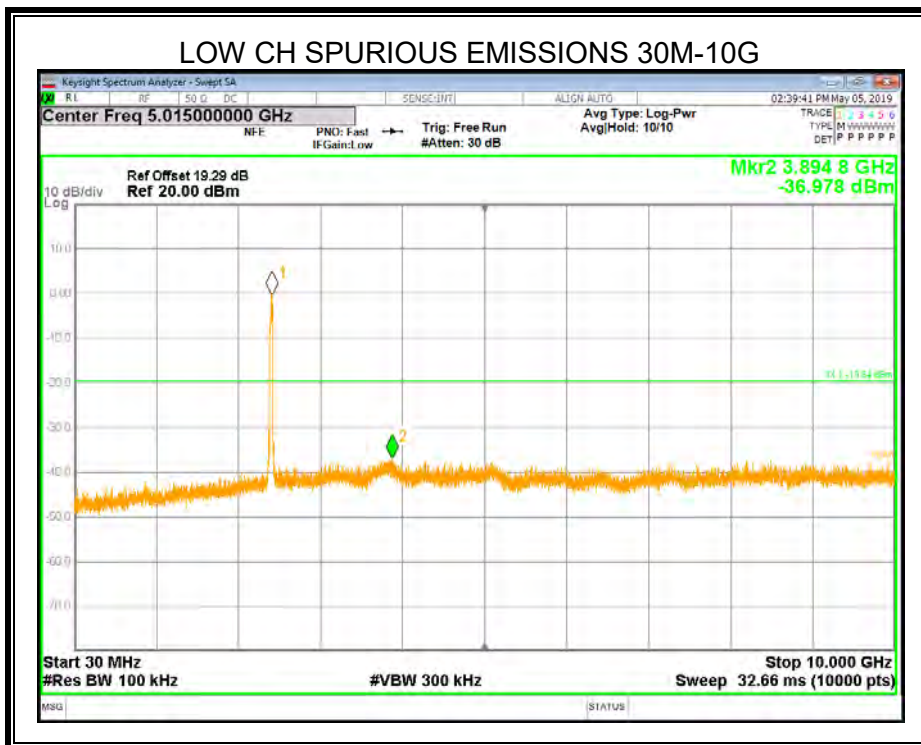
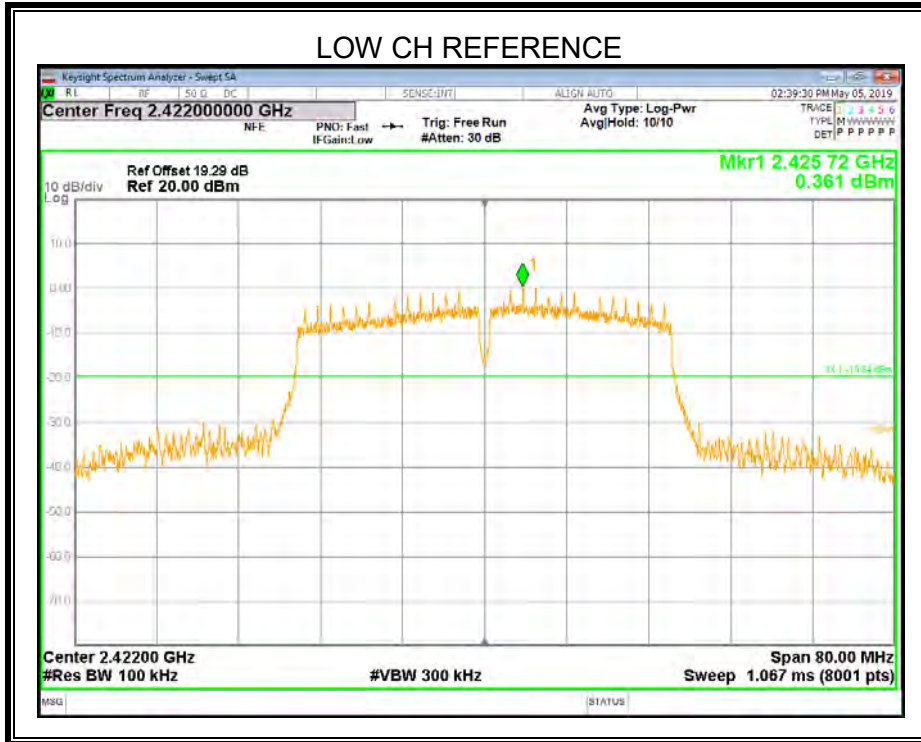

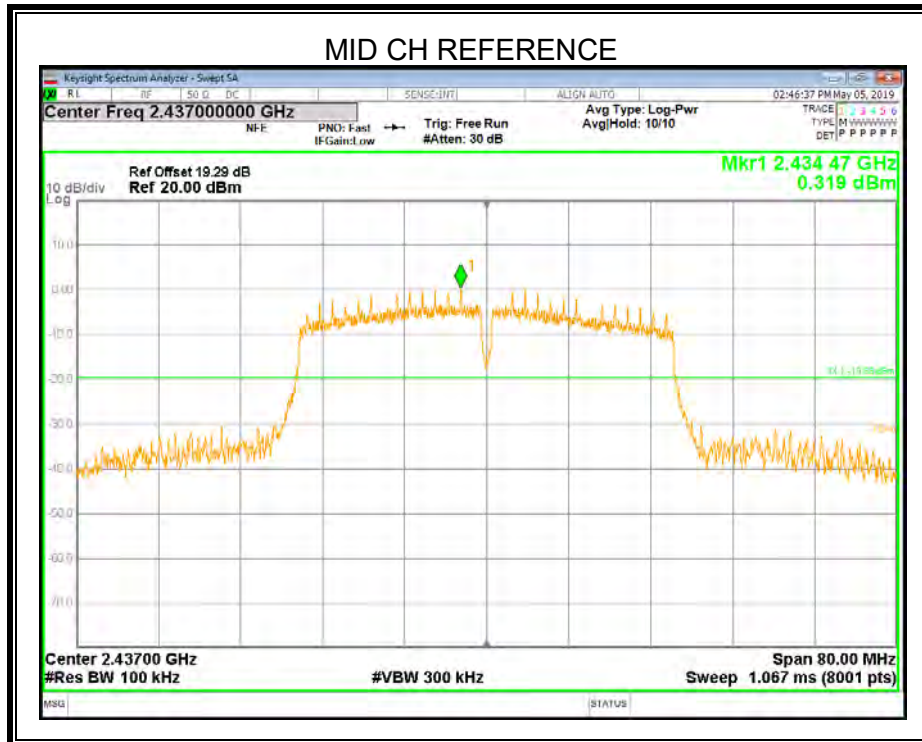
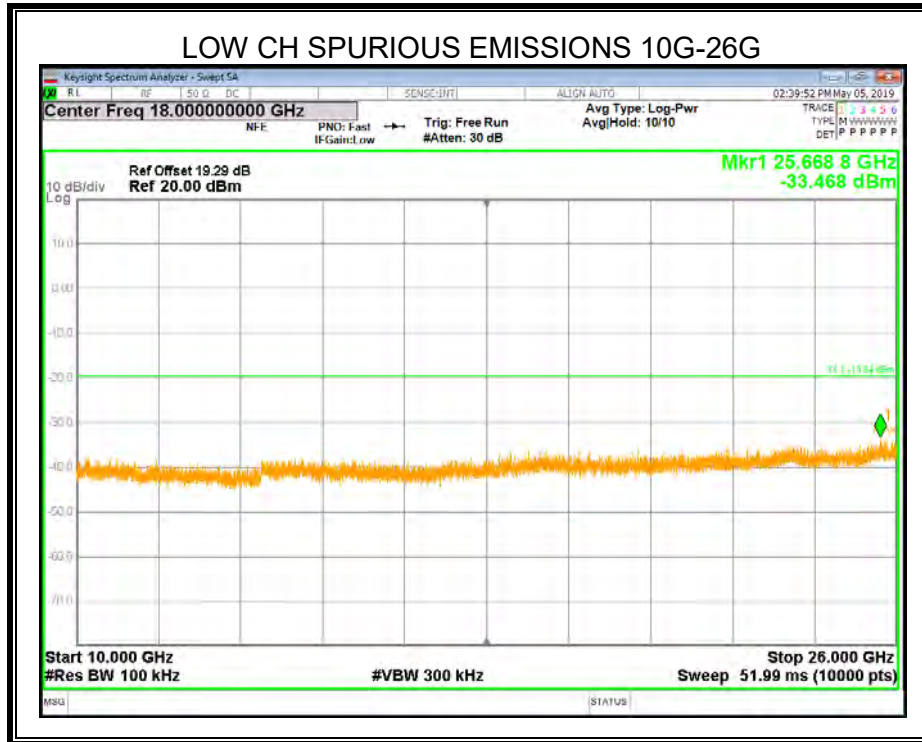

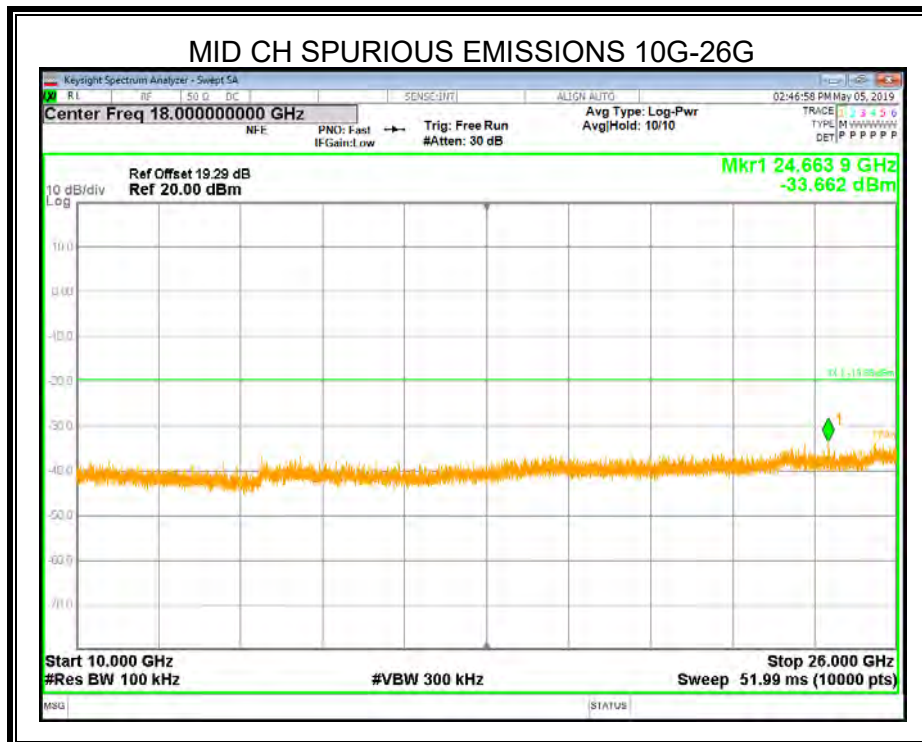
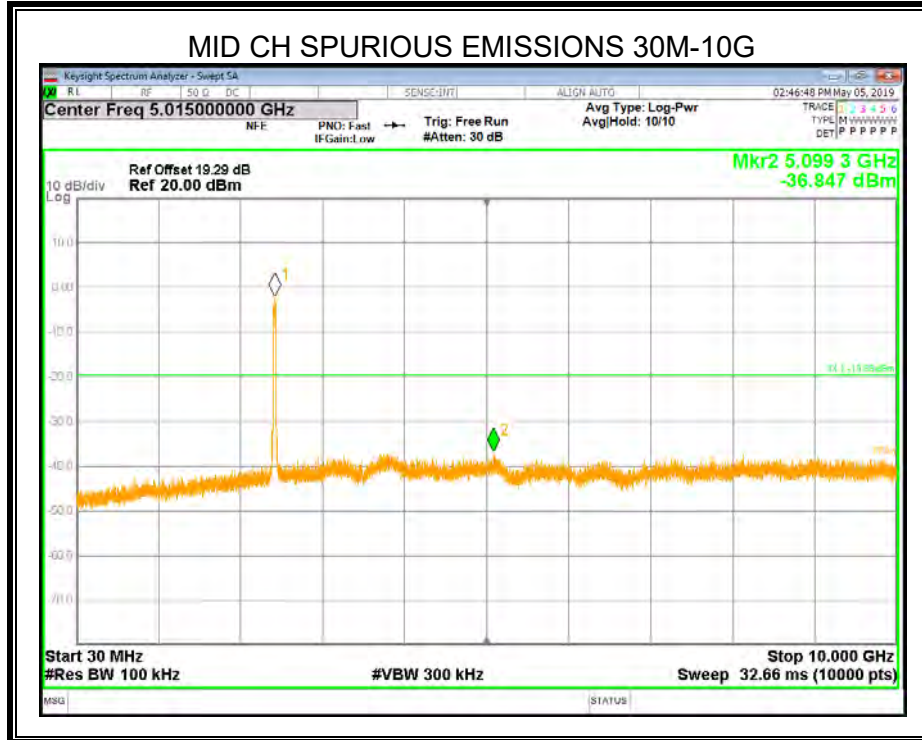

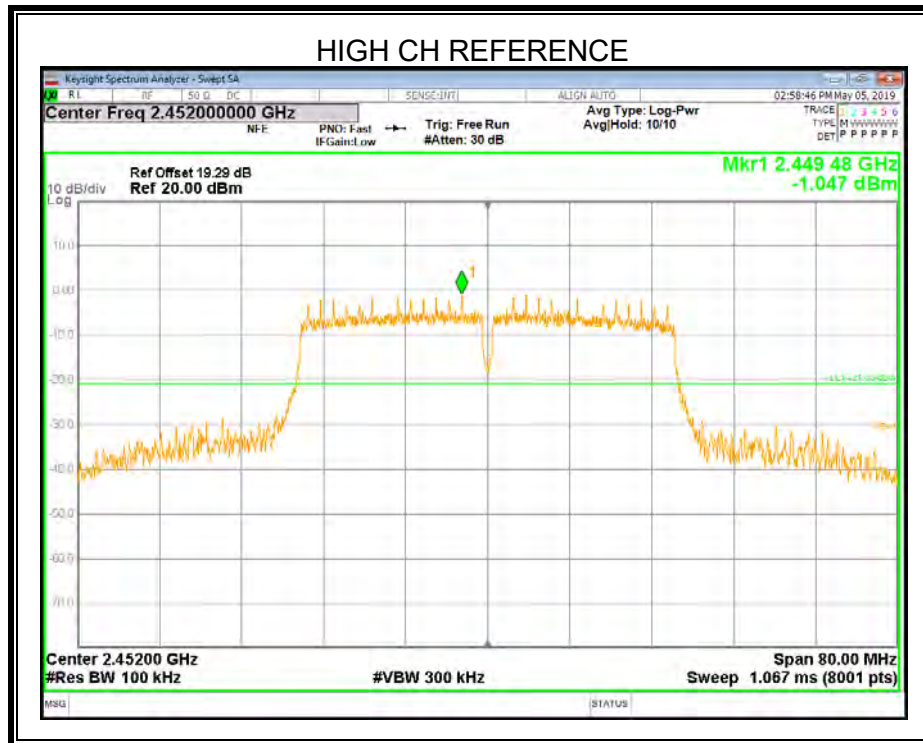
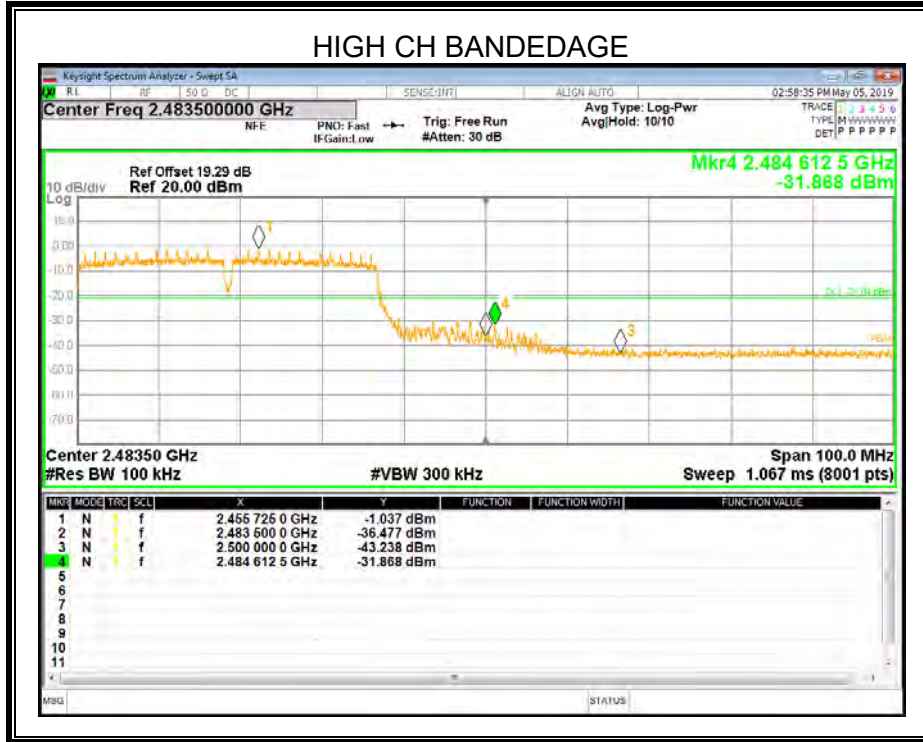

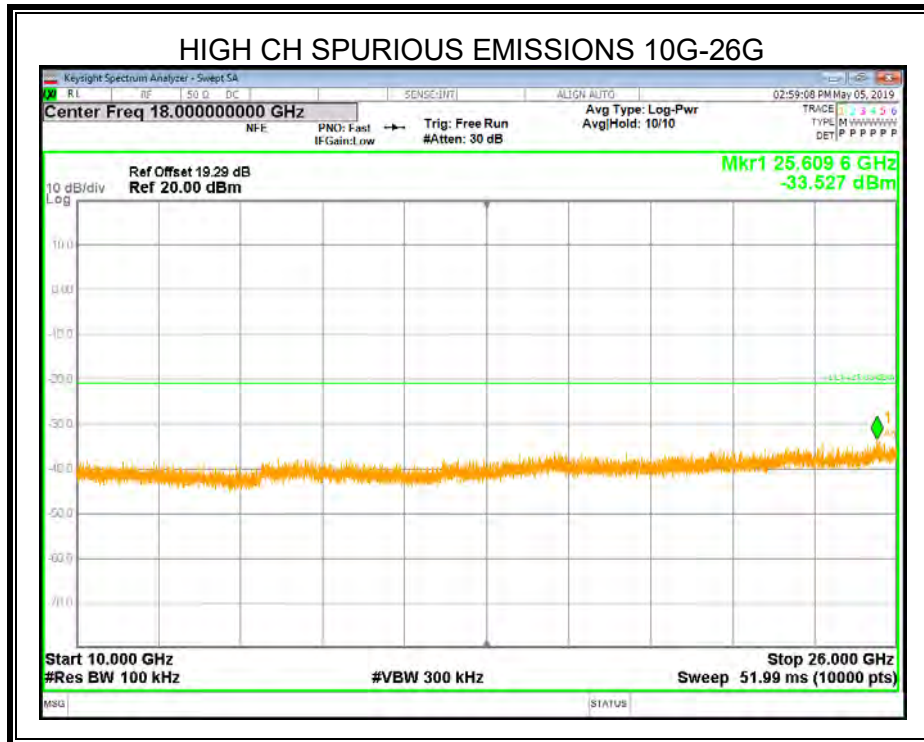
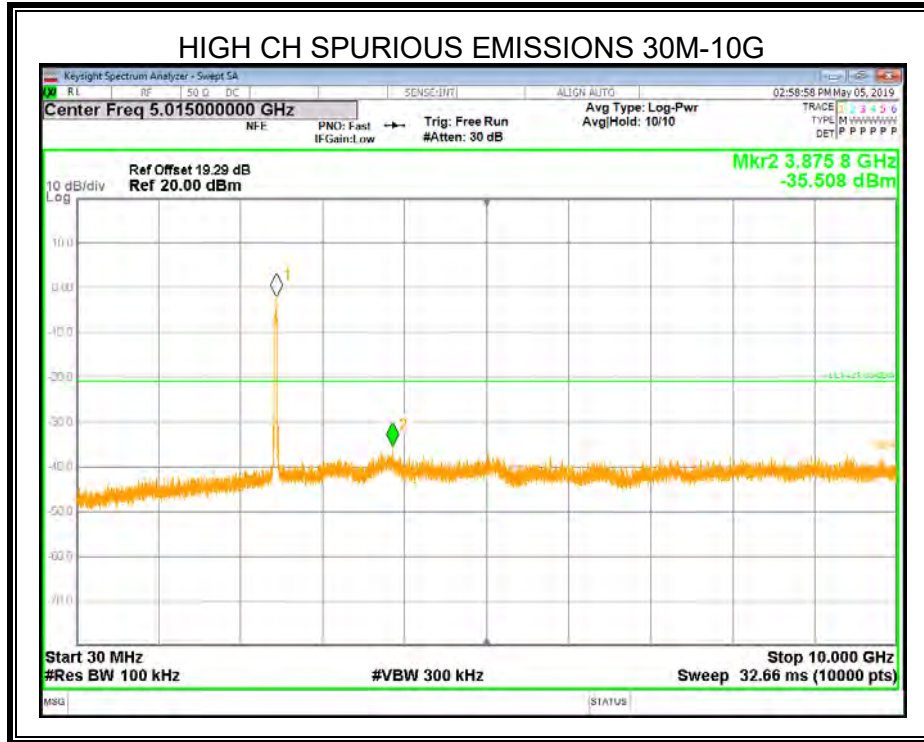



ANTENNA 1

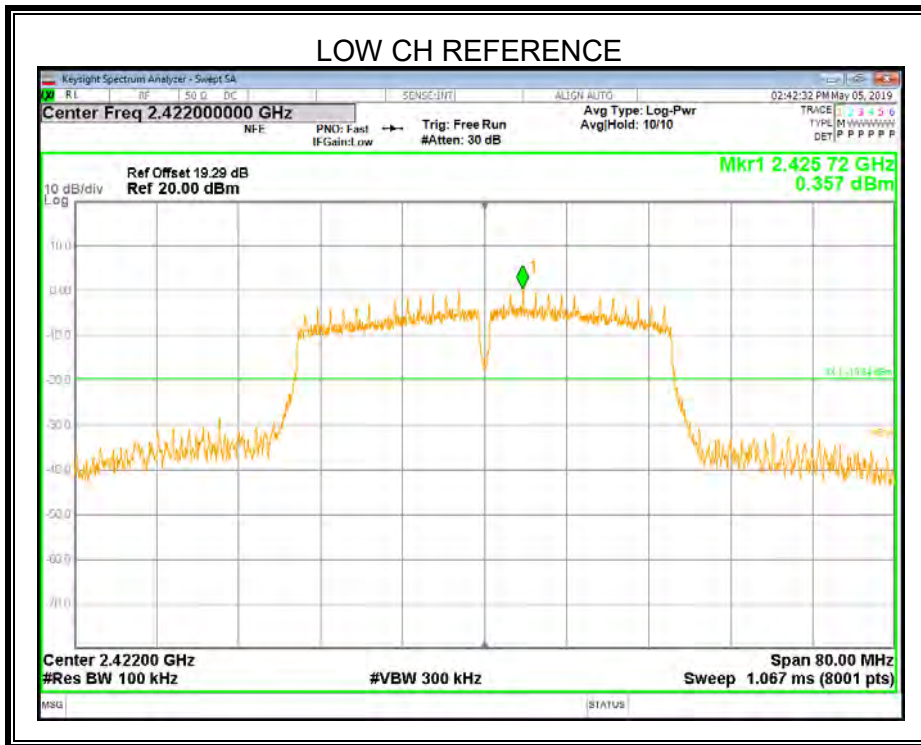
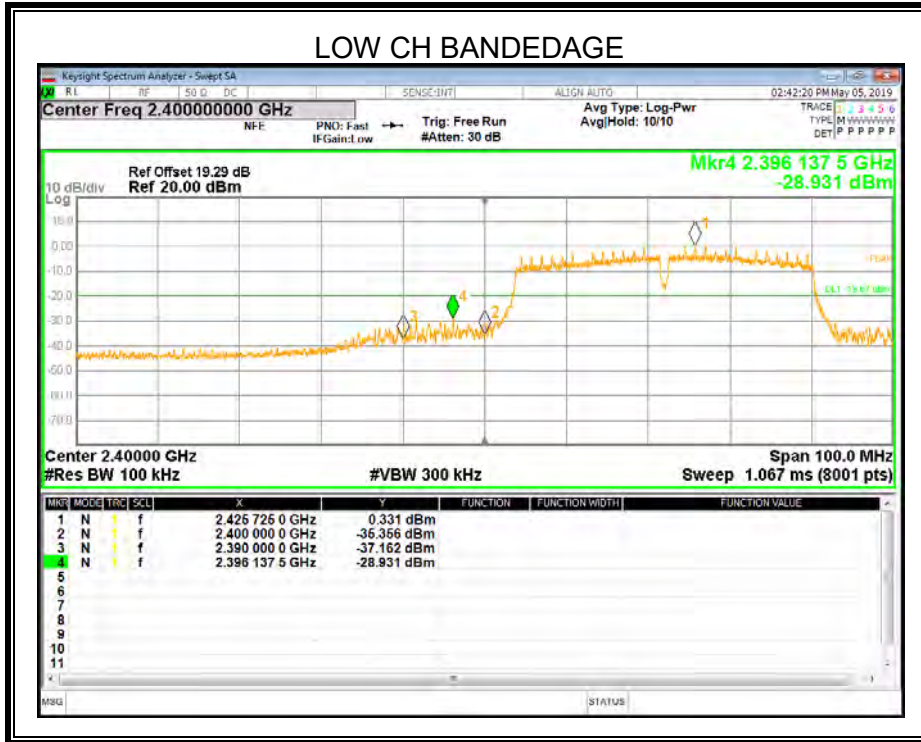

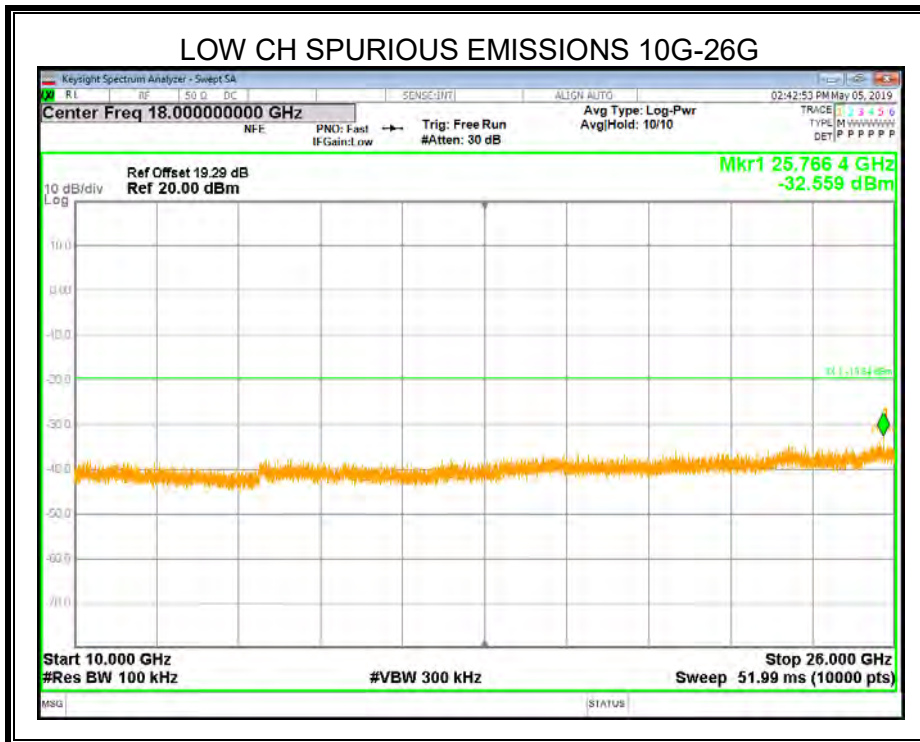
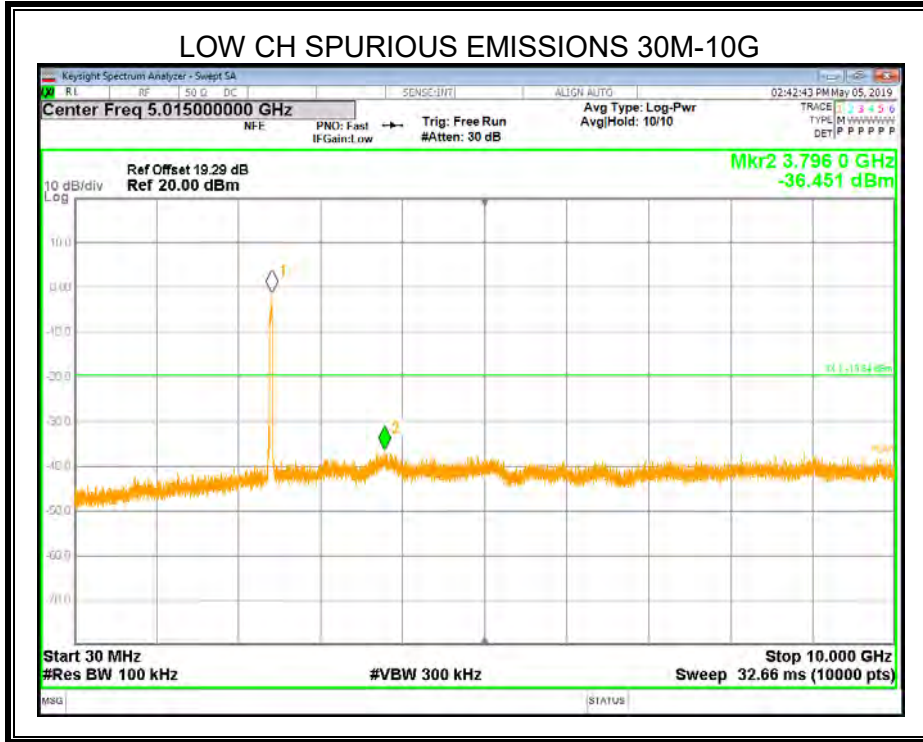

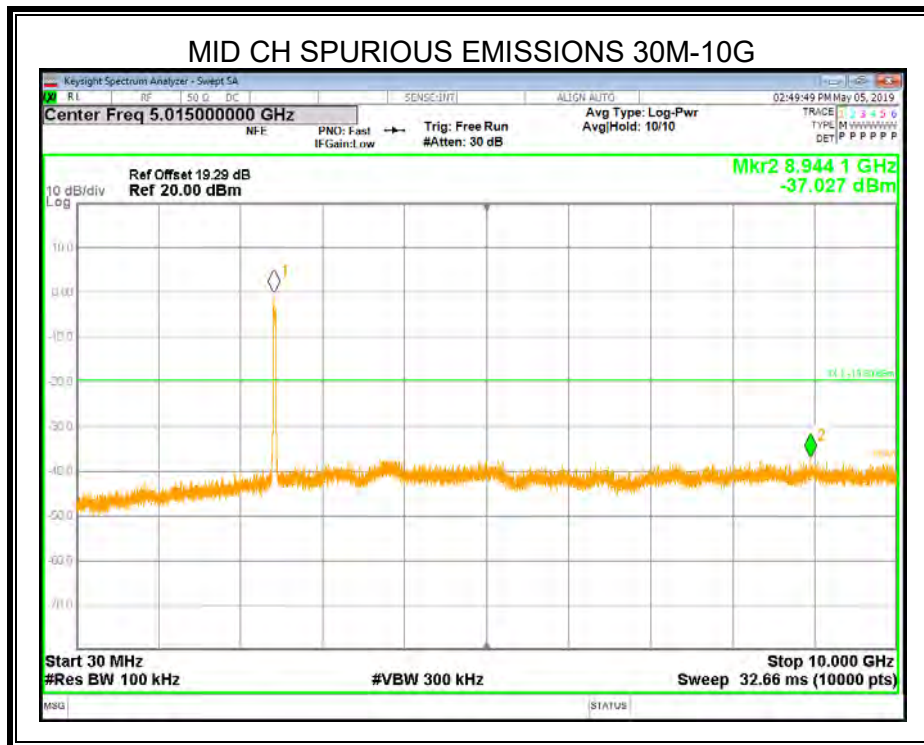
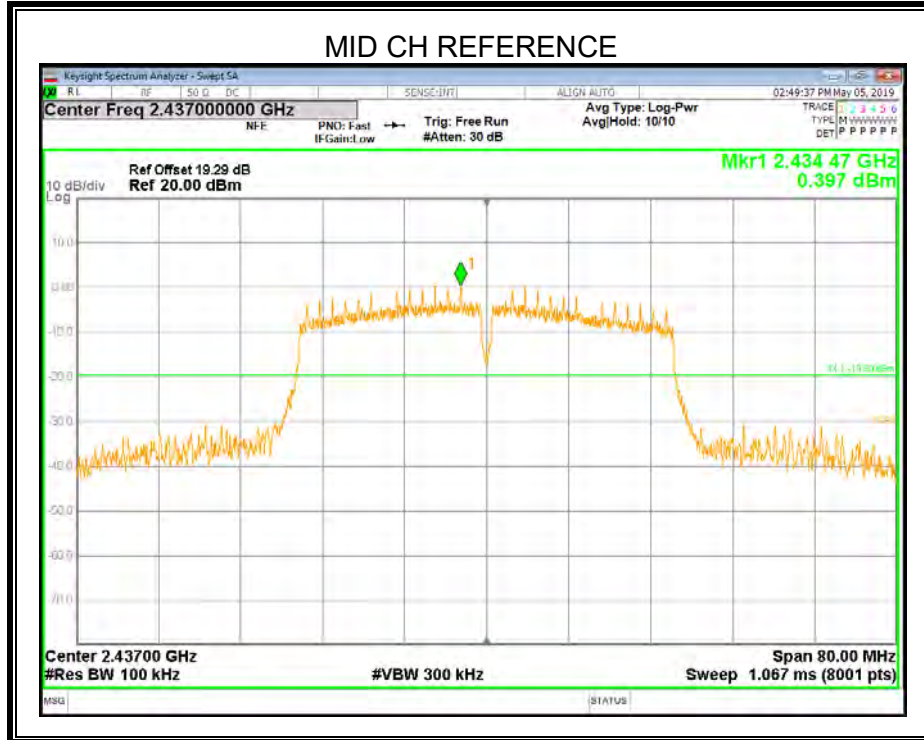

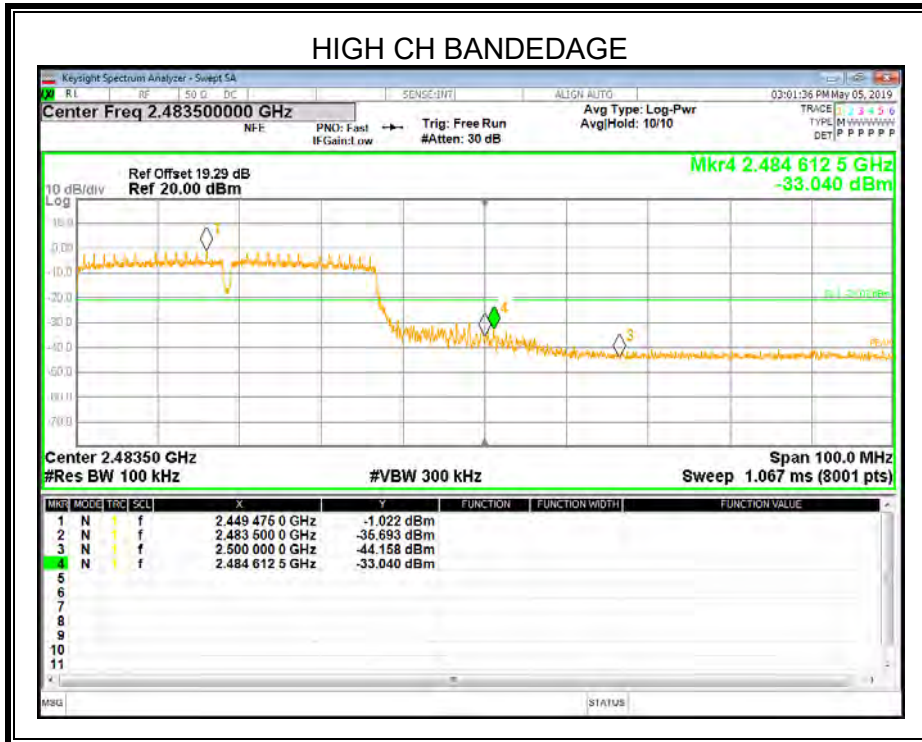
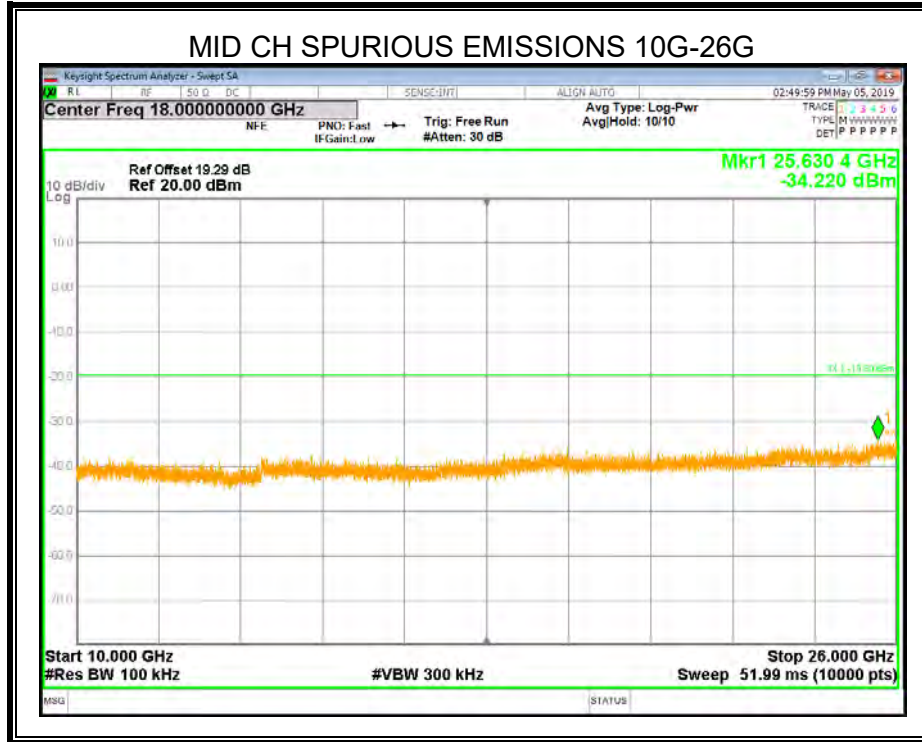

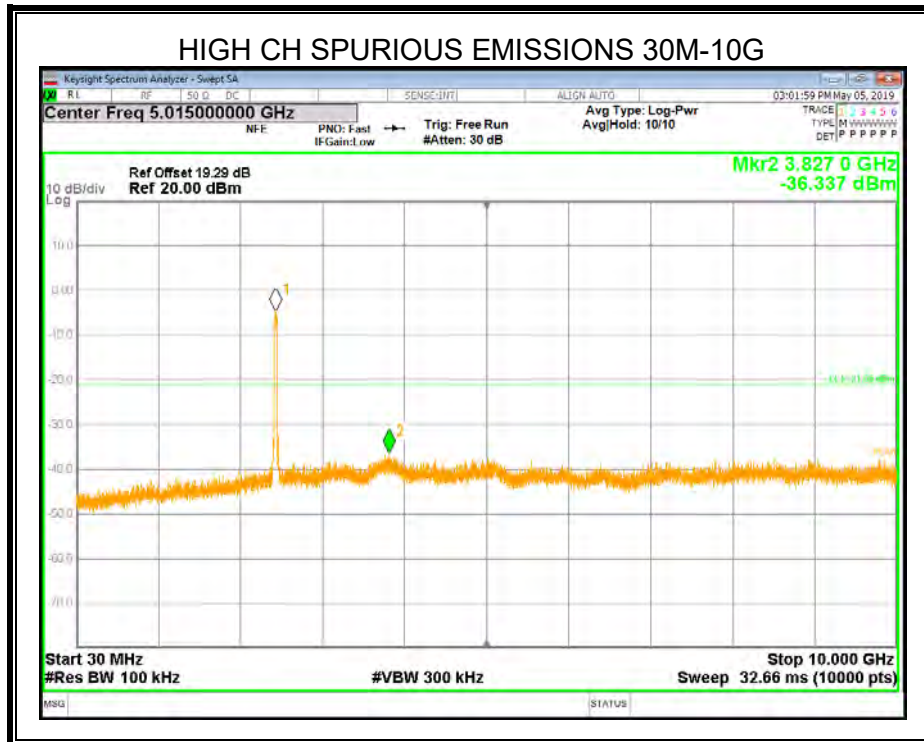
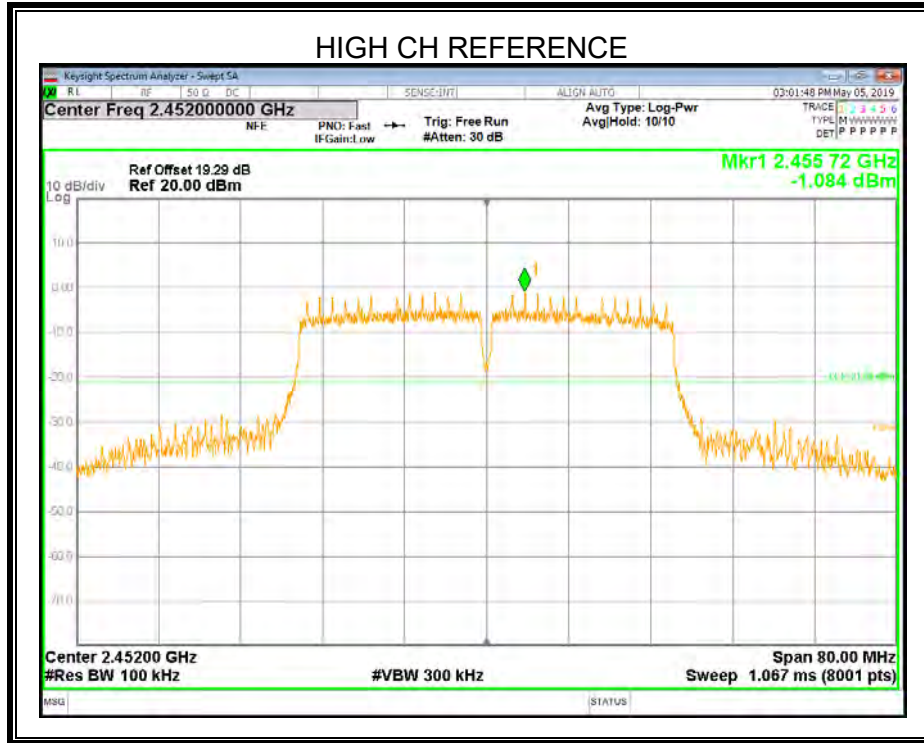

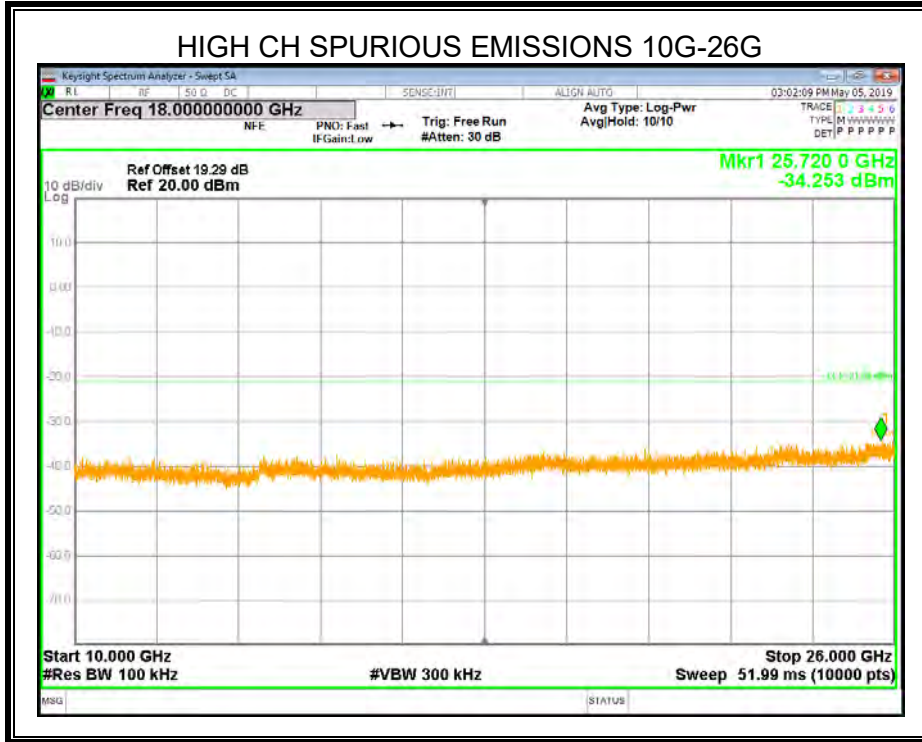



9. RADIATED TEST RESULTS

LIMITS

Please refer to CFR 47 FCC §15.205 and §15.209

Please refer to ISED RSS-GEN Clause 8.9 (Transmitter)

Radiation Disturbance Test Limit for FCC (Class B)(9KHz-1GHz)

Frequency (MHz)	Field Strength (microvolts/meter)	Measurement Distance (meters)
0.009~0.490	2400/F(KHz)	300
0.490~1.705	24000/F(KHz)	30
1.705~30.0	30	30
30~88	100	3
88~216	150	3
216~960	200	3
960~1000	500	3

Note: 1) At frequencies at or above 30 MHz, measurements may be performed at a distance other than what is specified provided: measurements are not made in the near field except where it can be shown that near field measurements are appropriate due to the characteristics of the device; and it can be demonstrated that the signal levels needed to be measured at the distance employed can be detected by the measurement equipment. Measurements shall not be performed at a distance greater than 30 meters unless it can be further demonstrated that measurements at a distance of 30 meters or less are impractical. When performing measurements at a distance other than that specified, the results shall be extrapolated to the specified distance using an extrapolation factor of 20 dB/decade (inverse linear-distance for field strength measurements; inverse-linear-distance-squared for power density measurements).

(2) At frequencies below 30 MHz, measurements may be performed at a distance closer than that specified in the regulations; however, an attempt should be made to avoid making measurements in the near field. Pending the development of an appropriate measurement procedure for measurements performed below 30 MHz, when performing measurements at a closer distance than specified, the results shall be extrapolated to the specified distance by either making measurements at a minimum of two distances on at least one radial to determine the proper extrapolation factor or by using the square of an inverse linear distance extrapolation factor (40 dB/decade). This paragraph (f) shall not apply to Access BPL devices operating below 30 MHz.

Radiation Disturbance Test Limit for FCC (Above 1G)

Frequency (MHz)	dB(uV/m) (at 3 meters)	
	Peak	Average



Above 1000	74	54
------------	----	----

IC Restricted bands please refer to ISED RSS-GEN Clause 8.10
FCC Restricted bands of operation:

MHz	MHz	MHz	GHz
0.090-0.110	16.42-16.423	399.9-410	4.5-5.15
¹ 0.495-0.505	16.69475-16.69525	608-614	5.35-5.46
2.1735-2.1905	16.80425-16.80475	960-1240	7.25-7.75
4.125-4.128	25.5-25.67	1300-1427	8.025-8.5
4.17725-4.17775	37.5-38.25	1435-1626.5	9.0-9.2
4.20725-4.20775	73-74.6	1645.5-1646.5	9.3-9.5
6.215-6.218	74.8-75.2	1660-1710	10.6-12.7
6.26775-6.26825	108-121.94	1718.8-1722.2	13.25-13.4
6.31175-6.31225	123-138	2200-2300	14.47-14.5
8.291-8.294	149.9-150.05	2310-2390	15.35-16.2
8.362-8.366	156.52475-156.52525	2483.5-2500	17.7-21.4
8.37625-8.38675	156.7-156.9	2690-2900	22.01-23.12
8.41425-8.41475	162.0125-167.17	3260-3267	23.6-24.0
12.29-12.293	167.72-173.2	3332-3339	31.2-31.8
12.51975-12.52025	240-285	3345.8-3358	36.43-36.5
12.57675-12.57725	322-335.4	3600-4400	(²)
13.36-13.41			

Note: ¹Until February 1, 1999, this restricted band shall be 0.490-0.510 MHz.
²Above 38.6c

TEST SETUP AND PROCEDURE

Below 30MHz

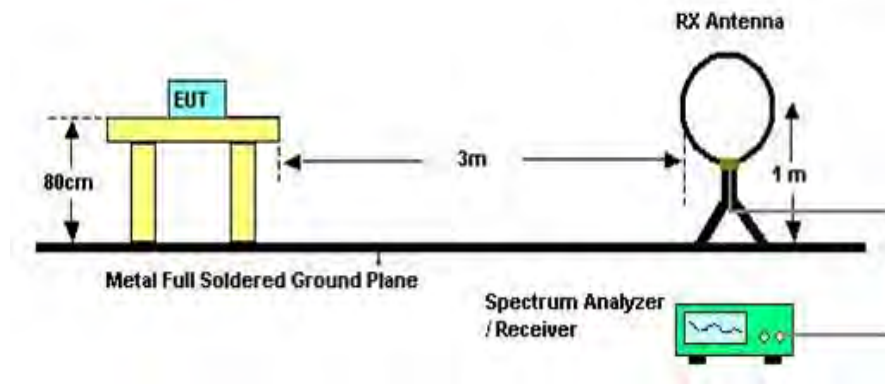

The setting of the spectrum analyser

RBW	200Hz (From 9kHz to 0.15MHz)/ 9KHz (From 0.15MHz to 30MHz)
VBW	200Hz (From 9kHz to 0.15MHz)/ 9KHz (From 0.15MHz to 30MHz)
Sweep	Auto
Detector	Peak/QP/ Average
Trace	Max hold

1. The testing follows the guidelines in ANSI C63.10-2013
2. The EUT was arranged to its worst case and then turntable (from 0 degree to 360 degrees) to find the maximum reading. A pre-amp and a high pass filter are used for the test in order to get better signal level. Both horizontal and vertical polarizations of the antenna are set to make the measurement.
3. The EUT was placed on a turntable with 80cm meter above ground.
4. The EUT was set 3 meters from the interference receiving antenna, which was mounted on the top of a variable height antenna tower.
5. The radiated emission limits are based on measurements employing a CISPR quasi-peak detector except for the frequency bands 9-90 kHz, 110-490 kHz and above 1000 MHz. Radiated emission limits in these three bands are based on measurements employing an average detector.
6. For measurement below 1GHz, the initial step in collecting conducted emission data is a spectrum analyzer peak detector mode pre-scanning the measurement frequency range. Significant peaks are then marked and then Quasi Peak detector mode re-measured. If the emission level of the EUT measured by the peak detector is 3 dB lower than the applicable limit, the peak emission level will be reported. Otherwise, the emission measurement will be repeated using the quasi-peak detector and reported.
7. Although these tests were performed other than open area test site, adequate comparison measurements were confirmed against 30m open area test site. Therefore sufficient tests were made to demonstrate that the alternative site produces results that correlate with the ones of tests made in an open field based on KDB 414788.

Below 1G

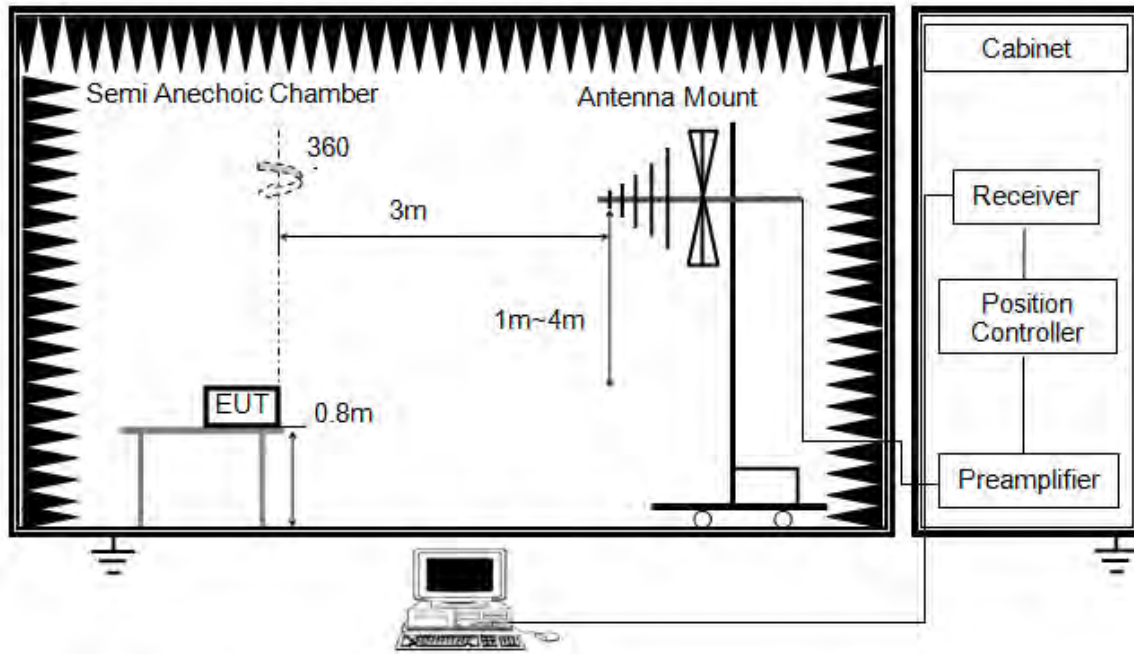

The setting of the spectrum analyser

RBW	120K
VBW	300K
Sweep	Auto
Detector	Peak/QP
Trace	Max hold

1. The testing follows the guidelines in ANSI C63.10-2013.
2. The EUT was arranged to its worst case and then tune the antenna tower (from 1 m to 4 m) and turntable (from 0 degree to 360 degrees) to find the maximum reading. A pre-amp and a high pass filter are used for the test in order to get better signal level. Both horizontal and vertical polarizations of the antenna are set to make the measurement.
3. The EUT was placed on a turntable with 0.8 meter above ground.
4. The EUT was set 3 meters from the interference receiving antenna, which was mounted on the top of a variable height antenna tower.
5. For measurement below 1GHz, the initial step in collecting conducted emission data is a spectrum analyzer peak detector mode pre-scanning the measurement frequency range. Significant peaks are then marked and then Quasi Peak detector mode re-measured. If the emission level of the EUT measured by the peak detector is 3 dB lower than the applicable limit, the peak emission level will be reported. Otherwise, the emission measurement will be repeated using the quasi-peak detector and reported.

ABOVE 1G

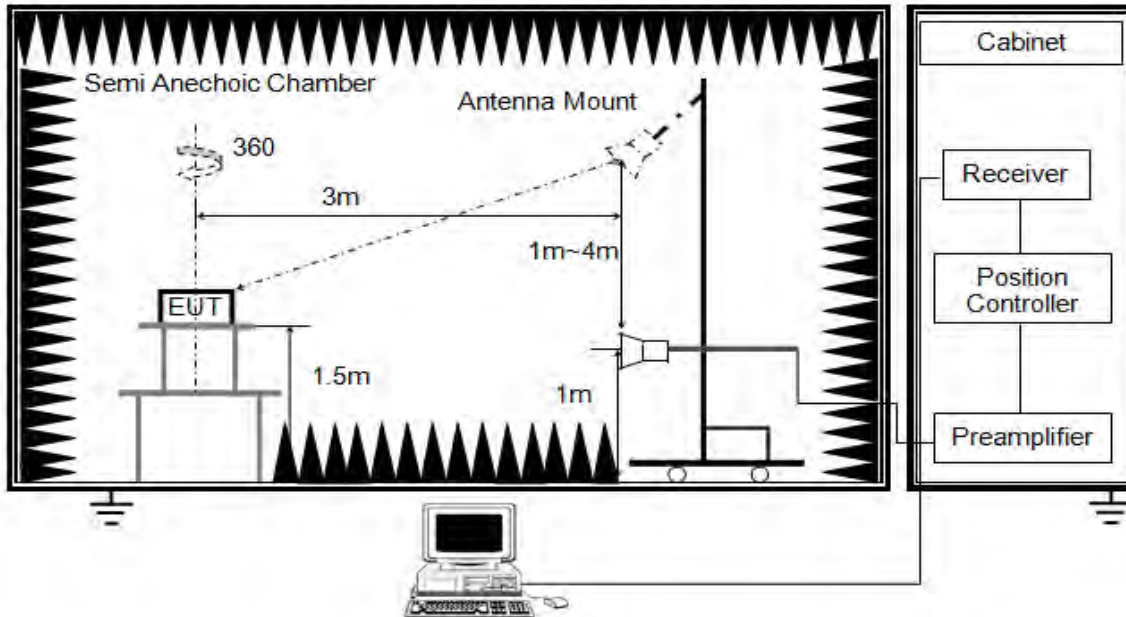

The setting of the spectrum analyser

RBW	1M
VBW	PEAK: 3M AVG: see note 6
Sweep	Auto
Detector	Peak
Trace	Max hold

1. The testing follows the guidelines in ANSI C63.10-2013.
2. The EUT was arranged to its worst case and then tune the antenna tower (from 1 m to 4 m) and turntable (from 0 degree to 360 degrees) to find the maximum reading. A pre-amp and a high pass filter are used for the test in order to get better signal level. Both horizontal and vertical polarizations of the antenna are set to make the measurement.
3. The EUT was placed on a turntable with 1.5m above ground.
4. The EUT was set 3 meters from the interference receiving antenna, which was mounted on the top of a variable height antenna tower.
5. For measurement above 1GHz, the emission measurement will be measured by the peak detector. This peak level, once corrected, must comply with the limit specified in Section 15.209.
6. For measurements above 1 GHz the resolution bandwidth is set to 1 MHz, then the video bandwidth is set to 3 MHz for peak measurements and 1 MHz resolution bandwidth with 1/T video bandwidth with peak detector for average measurements. For the Duty Cycle please refer to clause 8.1.ON TIME AND DUTY CYCLE.

X axis, Y axis, Z axis positions:

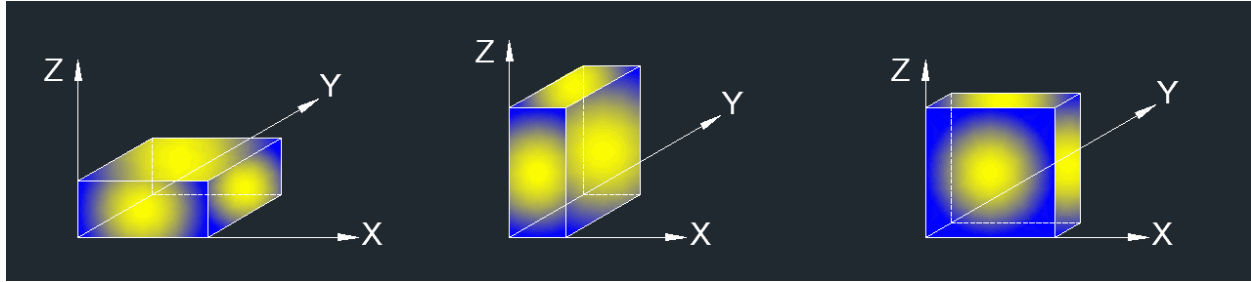

Note 1: For all radiated test, EUT in each of three orthogonal axis emissions had been tested, but only the worst case (X axis) data recorded in the report.

Note 2: All the EUT's emissions had been evaluated for simultaneous transmission with the other WIFI 2.4GHz and BT transmitter and there were no any additional or worse emissions found.

Note 3: The EUT was fully exercised with external accessories during the test. In the case of multiple accessory external ports, an external accessory shall be connected to one of each type of port.

TEST ENVIRONMENT

Temperature	23.9°C	Relative Humidity	58%
Atmosphere Pressure	101kPa	Test Voltage	DC 3.3V



9.1. RESTRICTED BANDEDGE

9.1.1. 802.11b SISO MODE

1TX MODE FOR ANT1 (WORST-CASE CONFIGURATION)

RESTRICTED BANDEDGE (LOW CHANNEL, HORIZONTAL)

PEAK

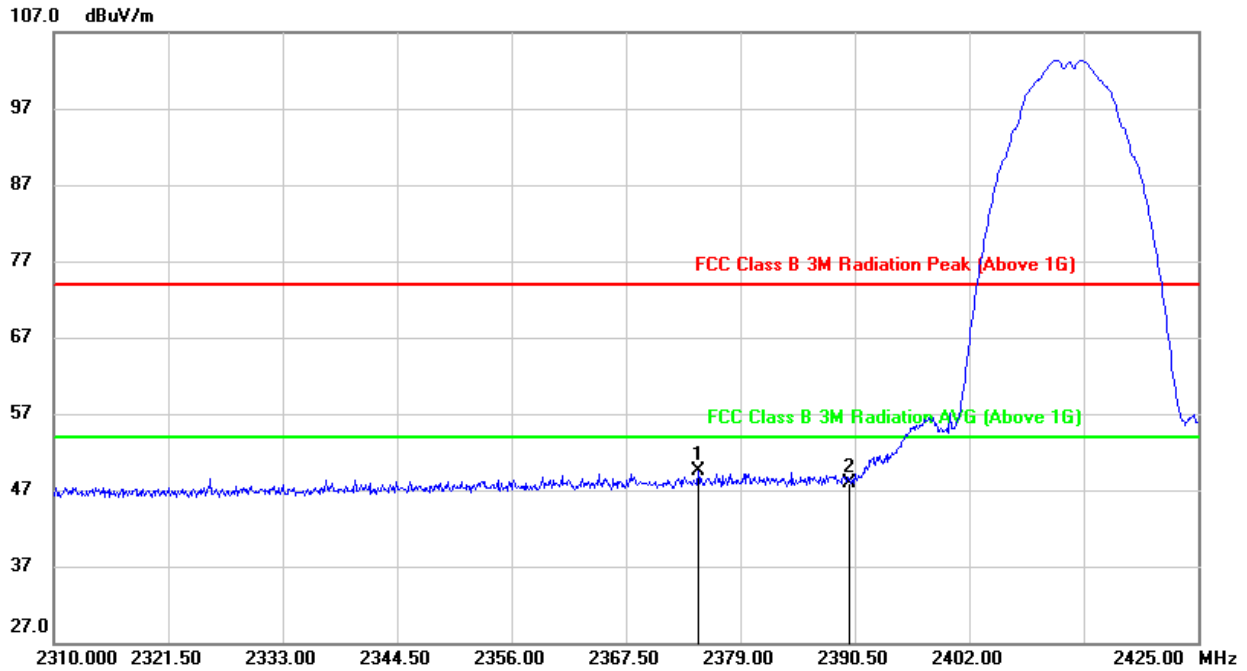

No.	Frequency (MHz)	Reading (dBuV)	Correct (dB/m)	Result (dBuV)	Limit (dBuV)	Margin (dB)	Remark
1	2374.745	16.56	32.89	49.45	74.00	-24.55	peak
2	2390.000	14.99	32.94	47.93	74.00	-26.07	peak

- Note:
1. Measurement = Reading Level + Correct Factor.
 2. If Peak Result complies with AV limit, AV Result is deemed to comply with AV limit.
 3. Peak: Peak detector.
 4. Only the worst case emission was recorded, if it complies with the limit, the other emissions deemed to comply with the limit.



RESTRICTED BANDEDGE (LOW CHANNEL, VERTICAL)

PEAK

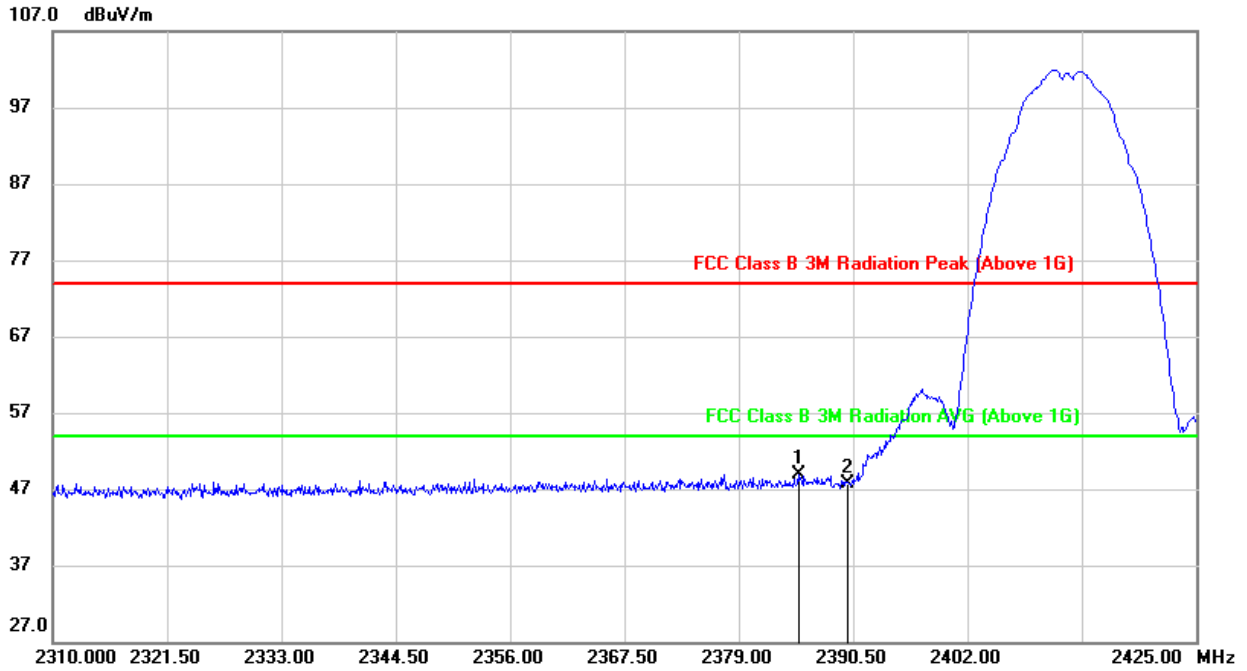

No.	Frequency (MHz)	Reading (dBuV)	Correct (dB/m)	Result (dBuV)	Limit (dBuV)	Margin (dB)	Remark
1	2384.980	15.93	32.93	48.86	74.00	-25.14	peak
2	2390.000	14.80	32.94	47.74	74.00	-26.26	peak

- Note:
1. Measurement = Reading Level + Correct Factor.
 2. If Peak Result complies with AV limit, AV Result is deemed to comply with AV limit.
 3. Peak: Peak detector.
 4. Only the worst case emission was recorded, if it complies with the limit, the other emissions deemed to comply with the limit.



RESTRICTED BANDEDGE (HIGH CHANNEL, HORIZONTAL)

PEAK

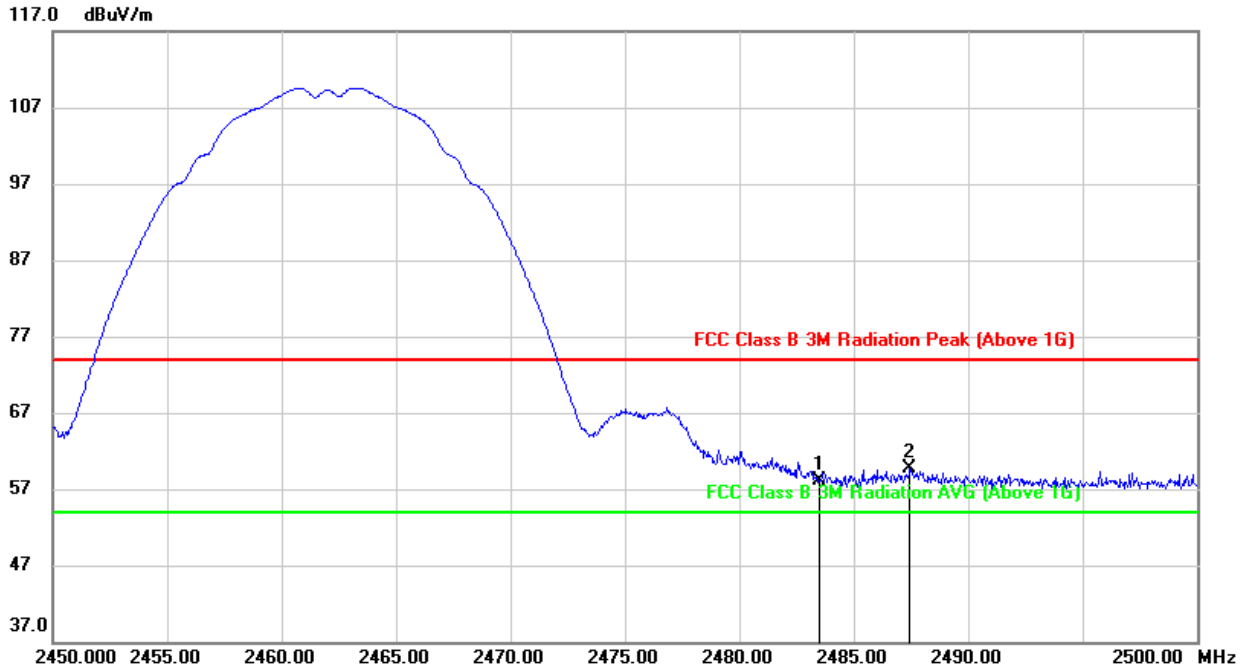

No.	Frequency (MHz)	Reading (dBuV)	Correct (dB/m)	Result (dBuV)	Limit (dBuV)	Margin (dB)	Remark
1	2483.500	24.43	33.58	58.01	74.00	-15.99	peak
2	2487.450	26.05	33.61	59.66	74.00	-14.34	peak

- Note: 1. Measurement = Reading Level + Correct Factor.
 2. If Peak Result complies with AV limit, AV Result is deemed to comply with AV limit.
 3. Peak: Peak detector.
 4. Only the worst case emission was recorded, if it complies with the limit, the other emissions deemed to comply with the limit.



AVG

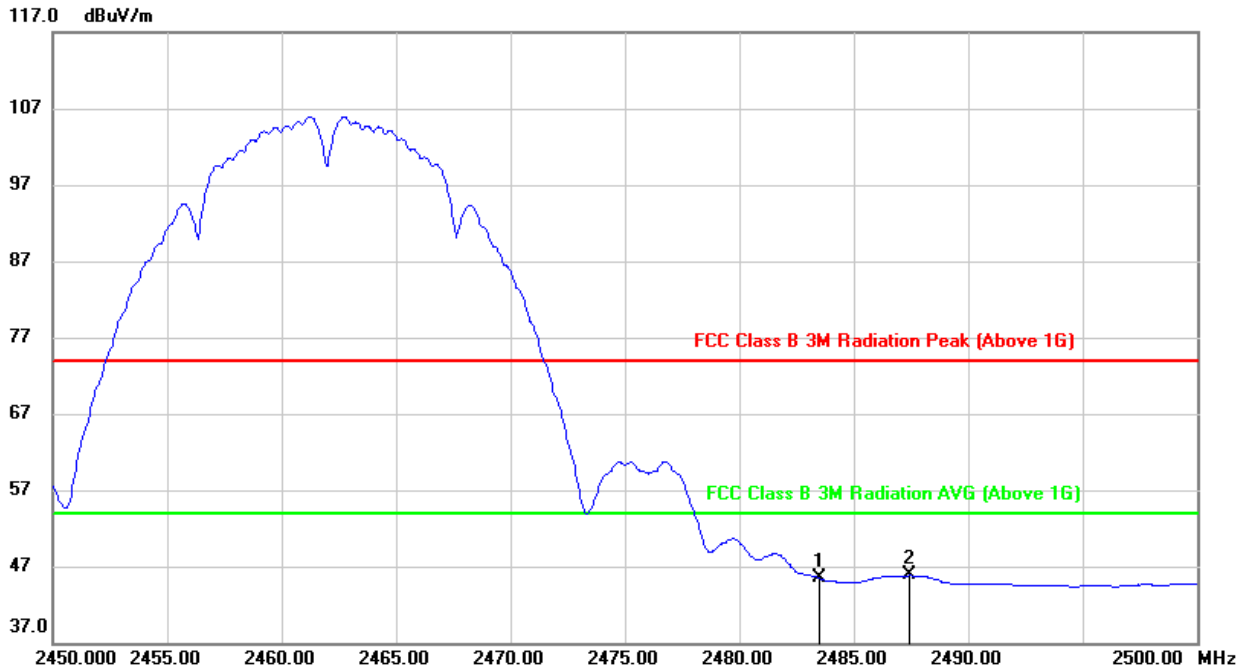

No.	Frequency (MHz)	Reading (dBuV)	Correct (dB/m)	Result (dBuV)	Limit (dBuV)	Margin (dB)	Remark
1	2483.500	11.85	33.58	45.43	54.00	-8.57	AVG
2	2487.450	12.26	33.61	45.87	54.00	-8.13	AVG

- Note:
1. Measurement = Reading Level + Correct Factor.
 2. If Peak Result complies with AV limit, AV Result is deemed to comply with AV limit.
 3. AVG: $VBW=1/T_{on}$ where: t_{on} is transmit duration.
 4. For transmit duration, please refer to clause 8.1.
 5. Only the worst case emission was recorded, if it complies with the limit, the other emissions deemed to comply with the limit.



RESTRICTED BANDEDGE (HIGH CHANNEL, VERTICAL)

PEAK

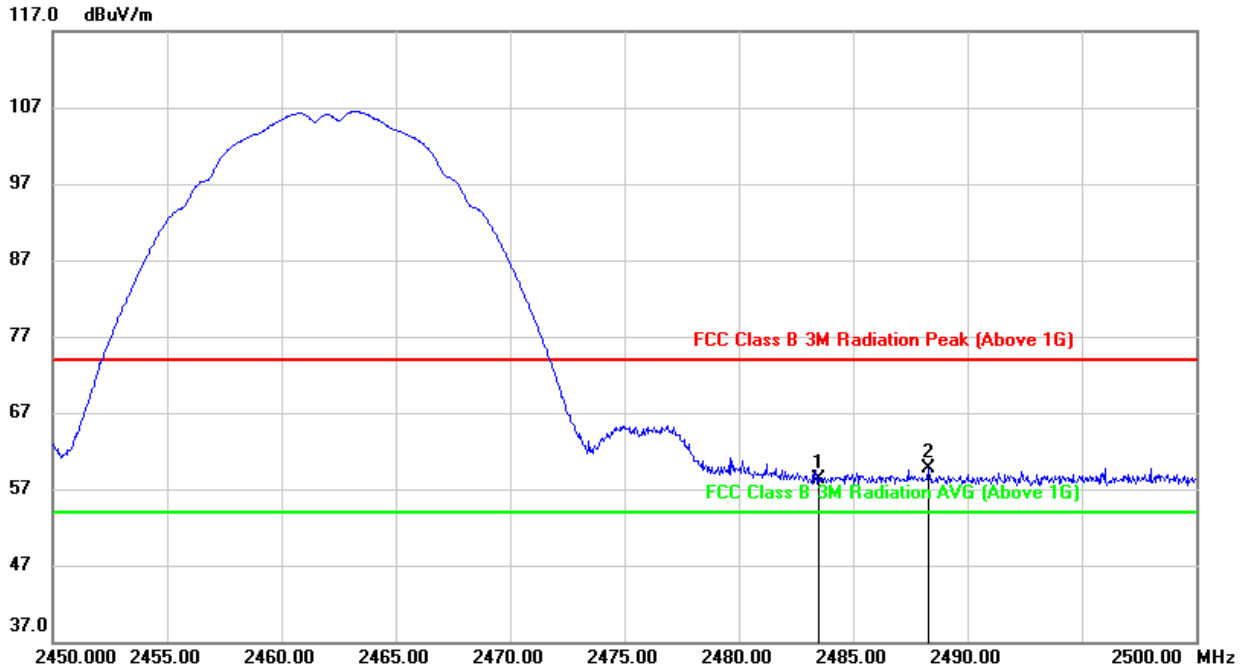

No.	Frequency (MHz)	Reading (dBuV)	Correct (dB/m)	Result (dBuV)	Limit (dBuV)	Margin (dB)	Remark
1	2483.500	24.63	33.58	58.21	74.00	-15.79	peak
2	2488.300	26.08	33.62	59.70	74.00	-14.30	peak

- Note: 1. Measurement = Reading Level + Correct Factor.
 2. If Peak Result complies with AV limit, AV Result is deemed to comply with AV limit.
 3. Peak: Peak detector.
 4. Only the worst case emission was recorded, if it complies with the limit, the other emissions deemed to comply with the limit.



AVG

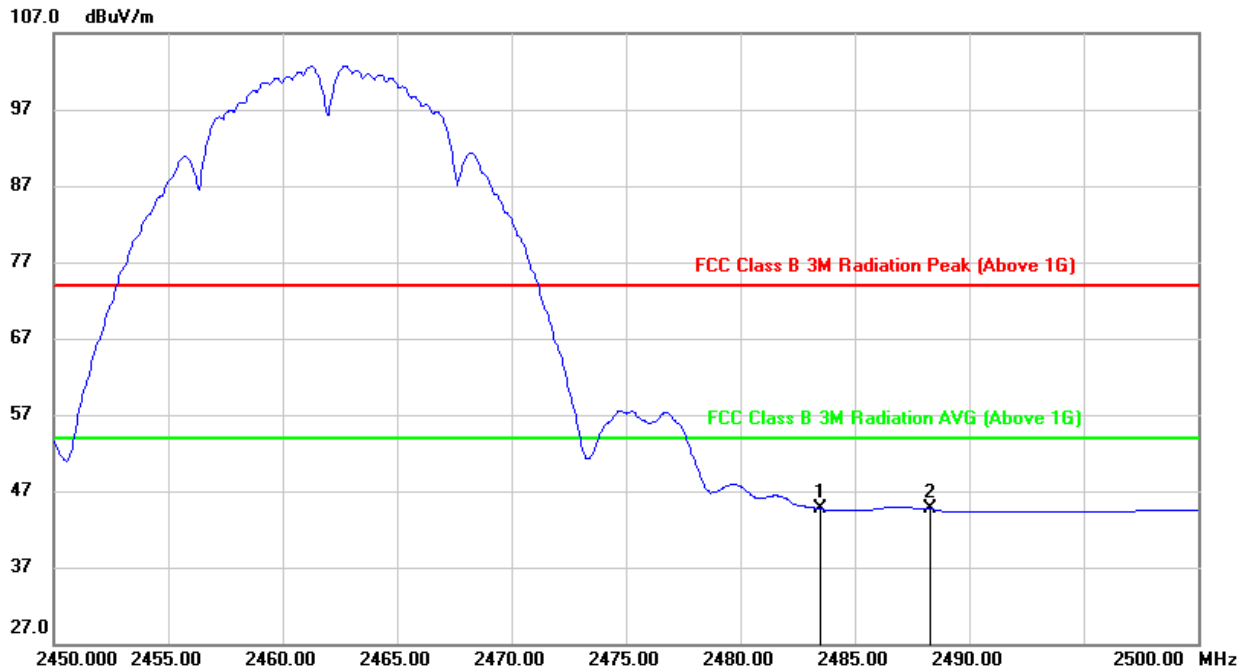

No.	Frequency (MHz)	Reading (dBuV)	Correct (dB/m)	Result (dBuV)	Limit (dBuV)	Margin (dB)	Remark
1	2483.500	11.16	33.58	44.74	54.00	-9.26	AVG
2	2488.300	11.02	33.62	44.64	54.00	-9.36	AVG

- Note:
1. Measurement = Reading Level + Correct Factor.
 2. If Peak Result complies with AV limit, AV Result is deemed to comply with AV limit.
 3. AVG: $VBW=1/T_{on}$ where: t_{on} is transmit duration.
 4. For transmit duration, please refer to clause 8.1.
 5. Only the worst case emission was recorded, if it complies with the limit, the other emissions deemed to comply with the limit.



9.1.2. 802.11g SISO MODE

1TX MODE FOR ANT1 (WORST-CASE CONFIGURATION)

RESTRICTED BANDEDGE (LOW CHANNEL, HORIZONTAL)

PEAK

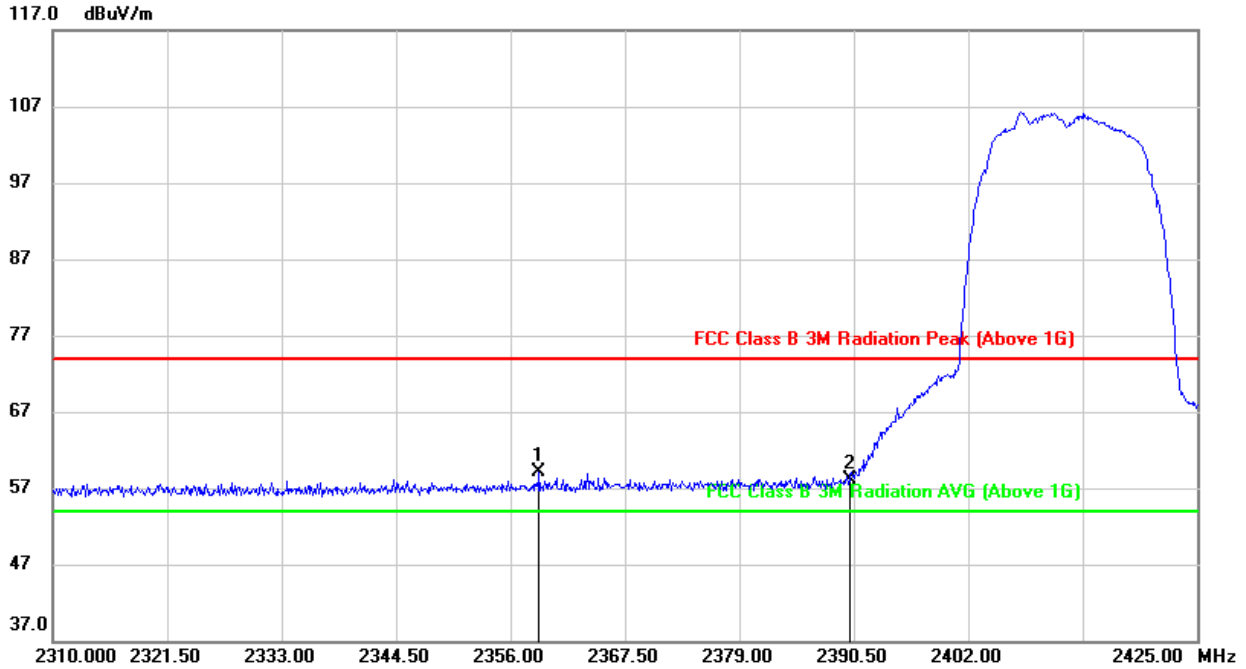

No.	Frequency (MHz)	Reading (dBuV)	Correct (dB/m)	Result (dBuV)	Limit (dBuV)	Margin (dB)	Remark
1	2358.875	26.23	32.84	59.07	74.00	-14.93	peak
2	2390.000	25.15	32.94	58.09	74.00	-15.91	peak

- Note: 1. Measurement = Reading Level + Correct Factor.
 2. If Peak Result complies with AV limit, AV Result is deemed to comply with AV limit.
 3. Peak: Peak detector.
 4. Only the worst case emission was recorded, if it complies with the limit, the other emissions deemed to comply with the limit.



AVG

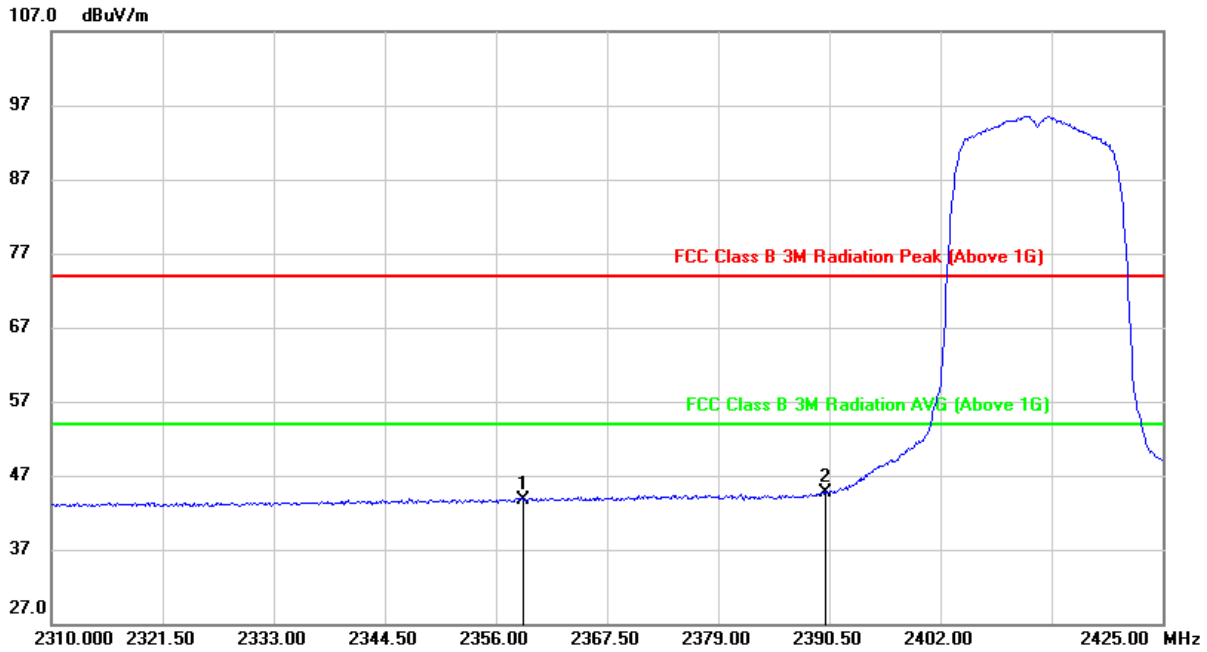

No.	Frequency (MHz)	Reading (dBuV)	Correct (dB/m)	Result (dBuV)	Limit (dBuV)	Margin (dB)	Remark
1	2358.875	10.86	32.84	43.70	54.00	-10.30	AVG
2	2390.000	11.86	32.94	44.80	54.00	-9.20	AVG

Note: 1. Measurement = Reading Level + Correct Factor.
 2. If Peak Result complies with AV limit, AV Result is deemed to comply with AV limit.
 3. AVG: VBW=1/Ton where: ton is transmit duration.
 4. For transmit duration, please refer to clause 8.1.
 5. Only the worst case emission was recorded, if it complies with the limit, the other emissions deemed to comply with the limit.



RESTRICTED BANDEDGE (LOW CHANNEL, VERTICAL)

PEAK

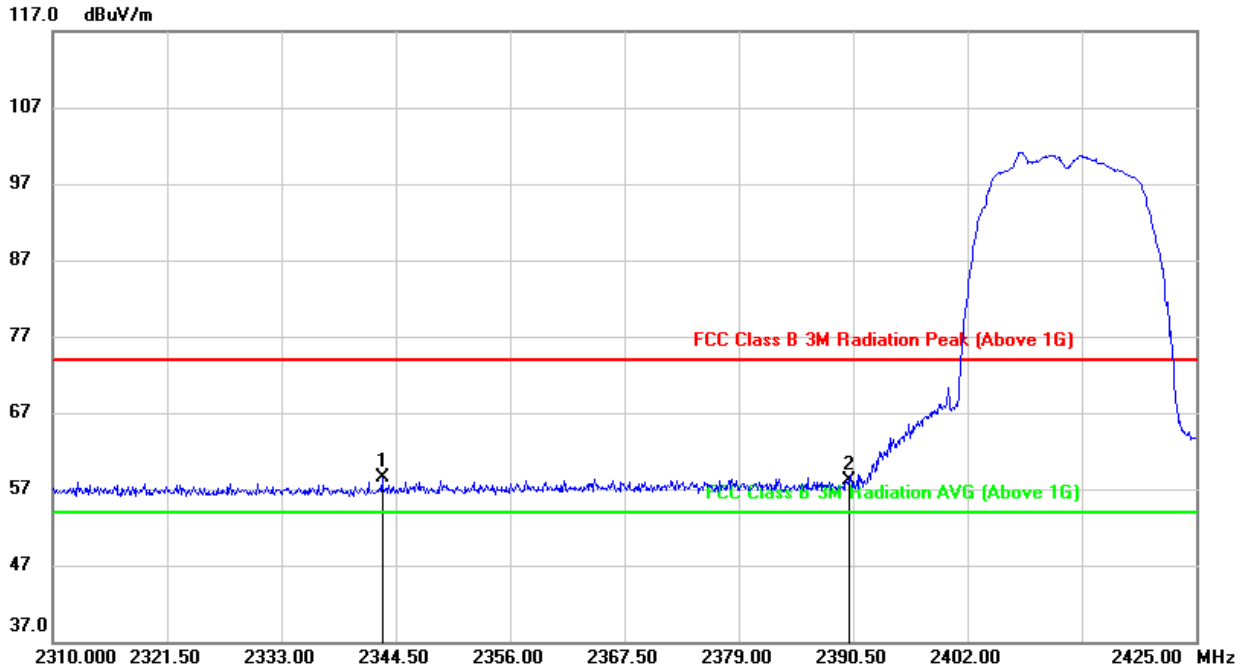

No.	Frequency (MHz)	Reading (dBuV)	Correct (dB/m)	Result (dBuV)	Limit (dBuV)	Margin (dB)	Remark
1	2343.120	25.63	32.79	58.42	74.00	-15.58	peak
2	2390.000	25.13	32.94	58.07	74.00	-15.93	peak

- Note:
1. Measurement = Reading Level + Correct Factor.
 2. If Peak Result complies with AV limit, AV Result is deemed to comply with AV limit.
 3. Peak: Peak detector.
 4. Only the worst case emission was recorded, if it complies with the limit, the other emissions deemed to comply with the limit.



AVG

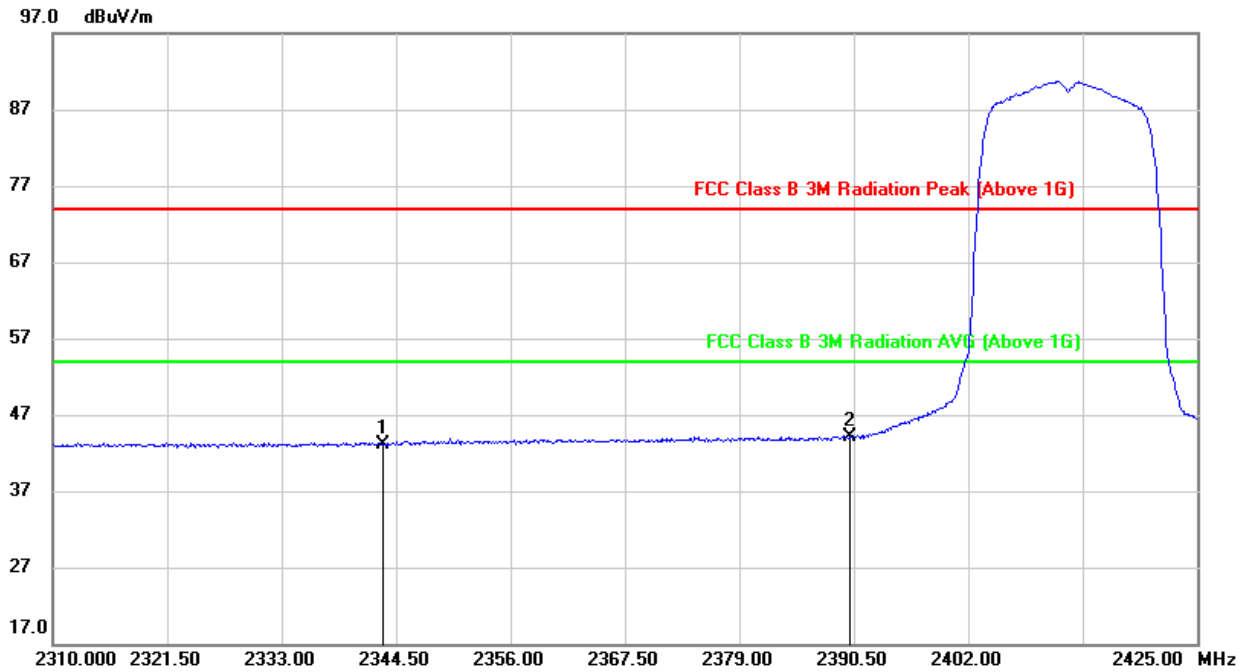

No.	Frequency (MHz)	Reading (dBuV)	Correct (dB/m)	Result (dBuV)	Limit (dBuV)	Margin (dB)	Remark
1	2343.120	10.38	32.79	43.17	54.00	-10.83	AVG
2	2390.000	11.08	32.94	44.02	54.00	-9.98	AVG

- Note:
1. Measurement = Reading Level + Correct Factor.
 2. If Peak Result complies with AV limit, AV Result is deemed to comply with AV limit.
 3. AVG: $VBW=1/T_{on}$ where: t_{on} is transmit duration.
 4. For transmit duration, please refer to clause 8.1.
 5. Only the worst case emission was recorded, if it complies with the limit, the other emissions deemed to comply with the limit.



RESTRICTED BANDEDGE (HIGH CHANNEL, HORIZONTAL)

PEAK

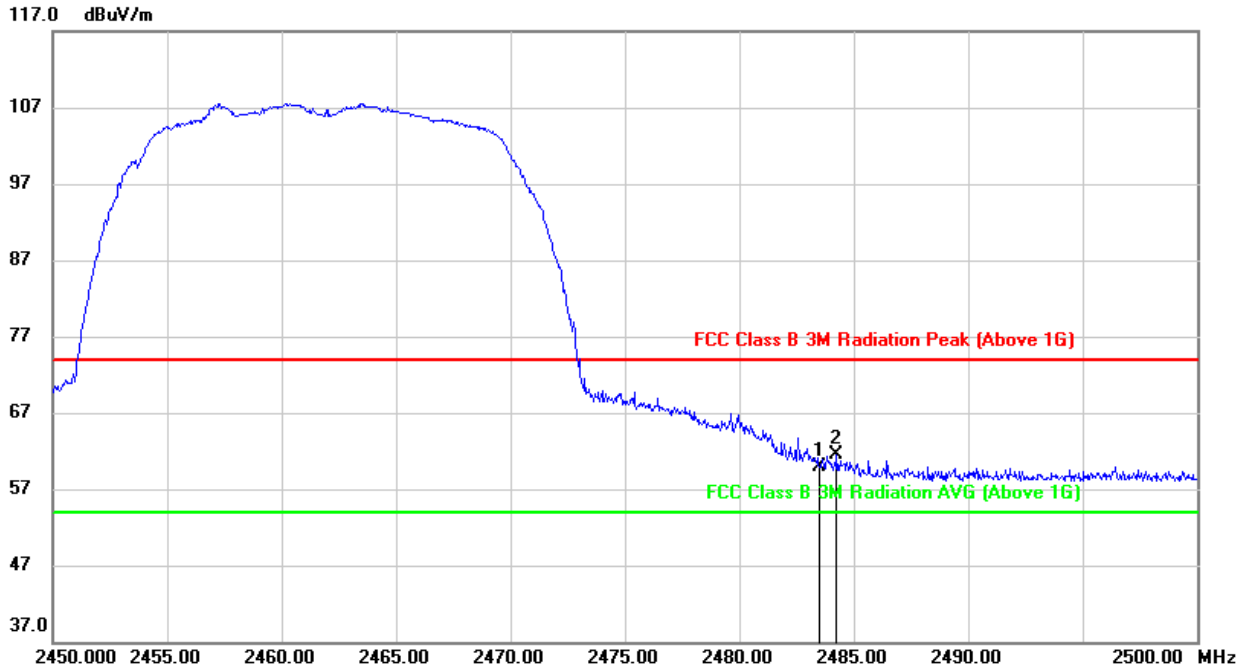

No.	Frequency (MHz)	Reading (dBuV)	Correct (dB/m)	Result (dBuV)	Limit (dBuV)	Margin (dB)	Remark
1	2483.500	26.39	33.58	59.97	74.00	-14.03	peak
2	2484.250	27.90	33.58	61.48	74.00	-12.52	peak

- Note: 1. Measurement = Reading Level + Correct Factor.
 2. If Peak Result complies with AV limit, AV Result is deemed to comply with AV limit.
 3. Peak: Peak detector.
 4. Only the worst case emission was recorded, if it complies with the limit, the other emissions deemed to comply with the limit.



AVG

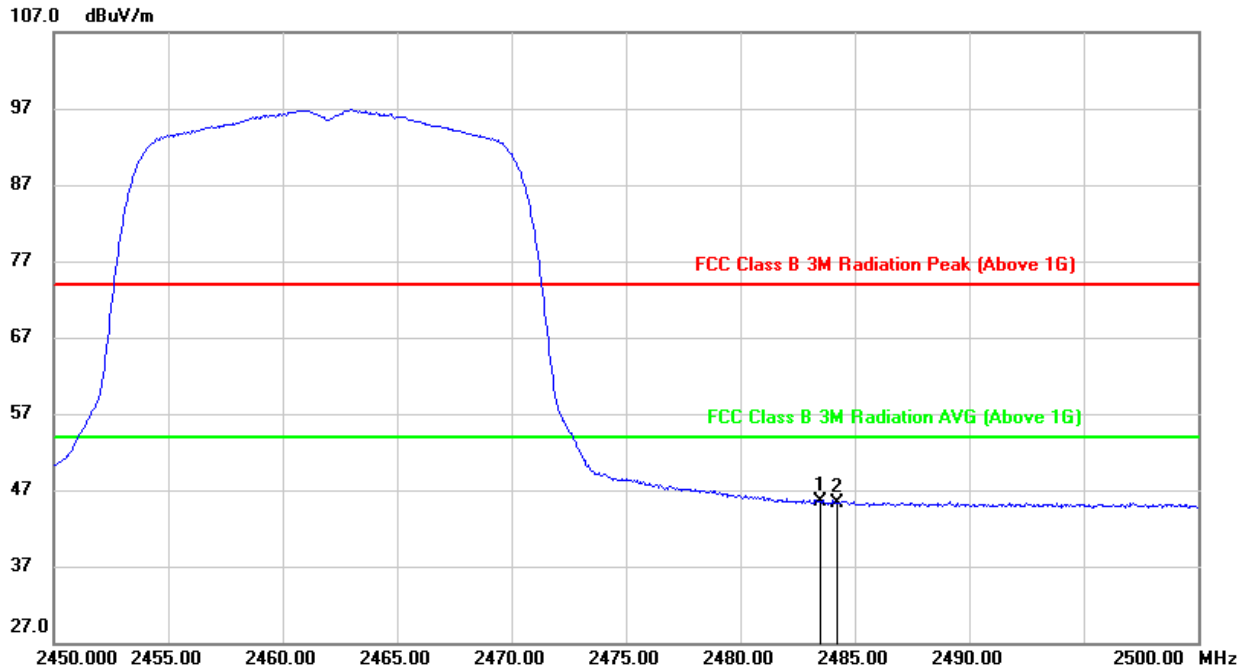

No.	Frequency (MHz)	Reading (dBuV)	Correct (dB/m)	Result (dBuV)	Limit (dBuV)	Margin (dB)	Remark
1	2483.500	11.89	33.58	45.47	54.00	-8.53	AVG
2	2484.250	11.78	33.58	45.36	54.00	-8.64	AVG

- Note:
1. Measurement = Reading Level + Correct Factor.
 2. If Peak Result complies with AV limit, AV Result is deemed to comply with AV limit.
 3. AVG: $VBW=1/T_{on}$ where: t_{on} is transmit duration.
 4. For transmit duration, please refer to clause 8.1.
 5. Only the worst case emission was recorded, if it complies with the limit, the other emissions deemed to comply with the limit.



RESTRICTED BANDEDGE (HIGH CHANNEL, VERTICAL)

PEAK

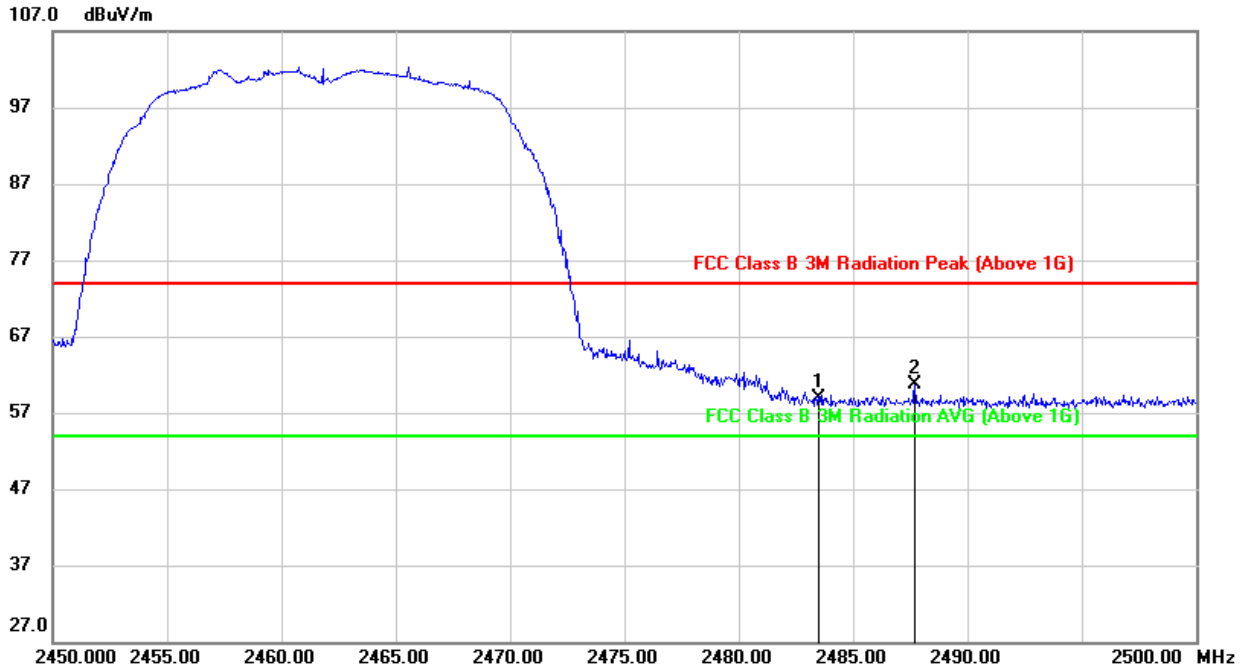

No.	Frequency (MHz)	Reading (dBuV)	Correct (dB/m)	Result (dBuV)	Limit (dBuV)	Margin (dB)	Remark
1	2483.500	25.42	33.58	59.00	74.00	-15.00	peak
2	2487.700	27.03	33.61	60.64	74.00	-13.36	peak

- Note: 1. Measurement = Reading Level + Correct Factor.
 2. If Peak Result complies with AV limit, AV Result is deemed to comply with AV limit.
 3. Peak: Peak detector.
 4. Only the worst case emission was recorded, if it complies with the limit, the other emissions deemed to comply with the limit.



AVG

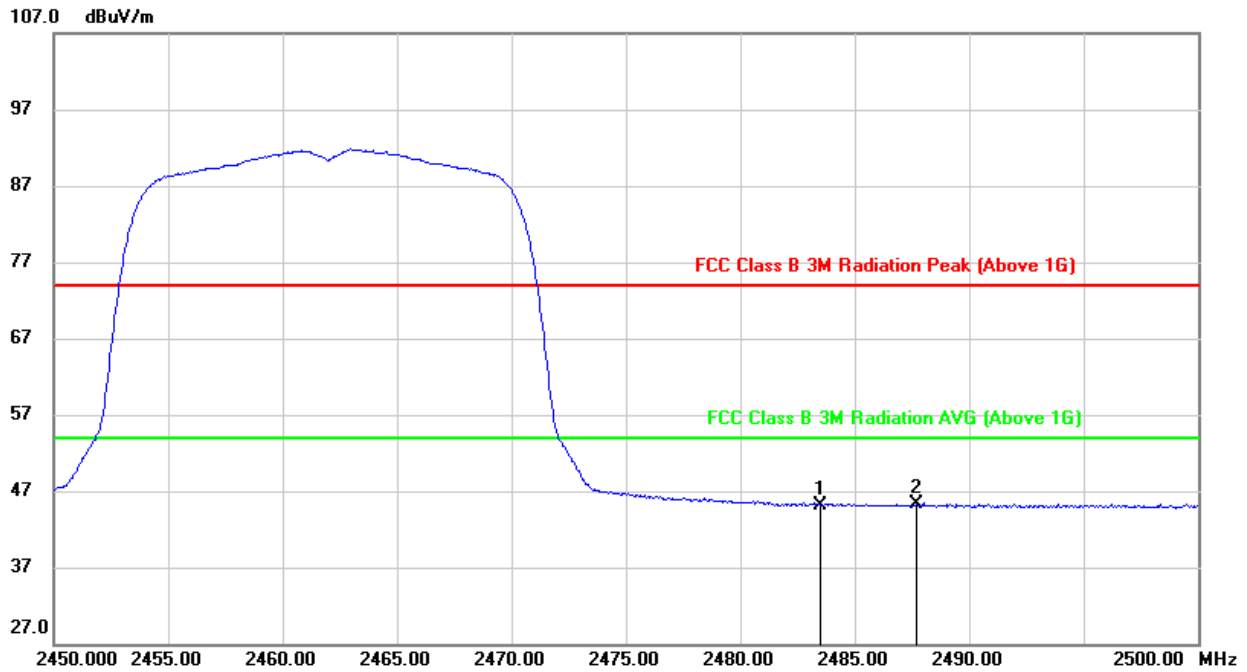

No.	Frequency (MHz)	Reading (dBuV)	Correct (dB/m)	Result (dBuV)	Limit (dBuV)	Margin (dB)	Remark
1	2483.500	11.60	33.58	45.18	54.00	-8.82	AVG
2	2487.700	11.60	33.61	45.21	54.00	-8.79	AVG

- Note: 1. Measurement = Reading Level + Correct Factor.
 2. If Peak Result complies with AV limit, AV Result is deemed to comply with AV limit.
 3. AVG: $VBW=1/T_{on}$ where: t_{on} is transmit duration.
 4. For transmit duration, please refer to clause 8.1.
 5. Only the worst case emission was recorded, if it complies with the limit, the other emissions deemed to comply with the limit.



9.1.3. 802.11n HT20 MIMO MODE

2TX MODE (WORST-CASE CONFIGURATION)

RESTRICTED BANDEDGE (LOW CHANNEL, HORIZONTAL)

PEAK

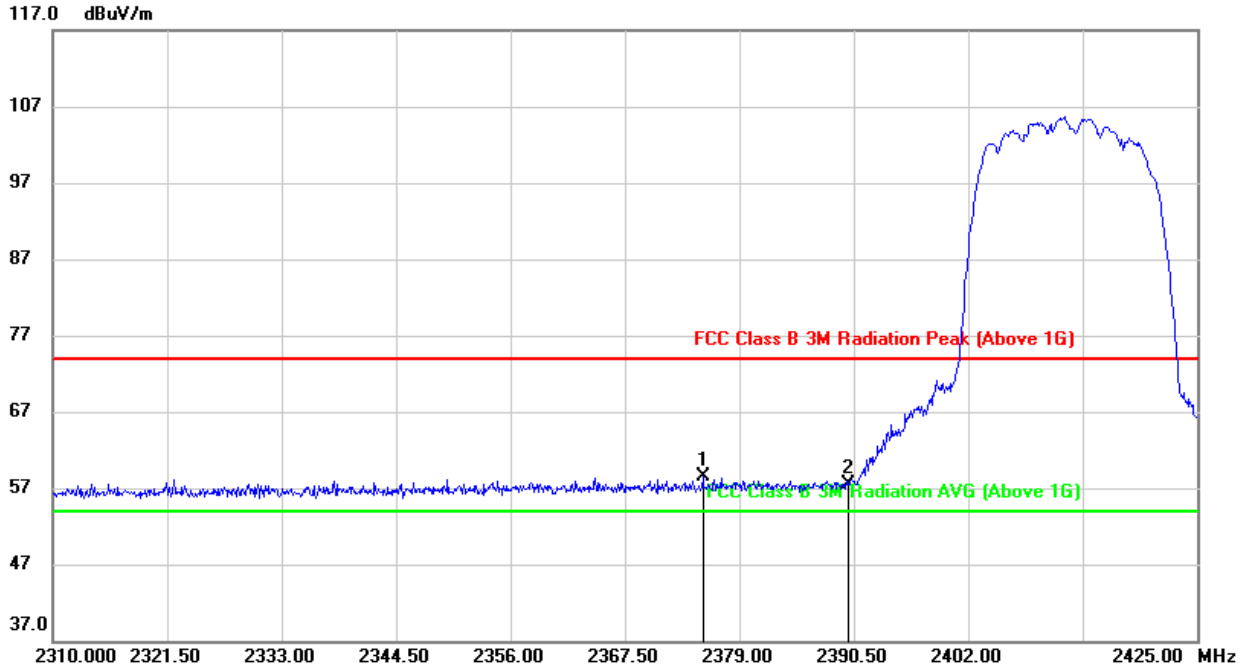

No.	Frequency (MHz)	Reading (dBuV)	Correct (dB/m)	Result (dBuV)	Limit (dBuV)	Margin (dB)	Remark
1	2375.320	25.55	32.90	58.45	74.00	-15.55	peak
2	2390.000	24.47	32.94	57.41	74.00	-16.59	peak

- Note: 1. Measurement = Reading Level + Correct Factor.
 2. If Peak Result complies with AV limit, AV Result is deemed to comply with AV limit.
 3. Peak: Peak detector.
 4. Only the worst case emission was recorded, if it complies with the limit, the other emissions deemed to comply with the limit.



AVG

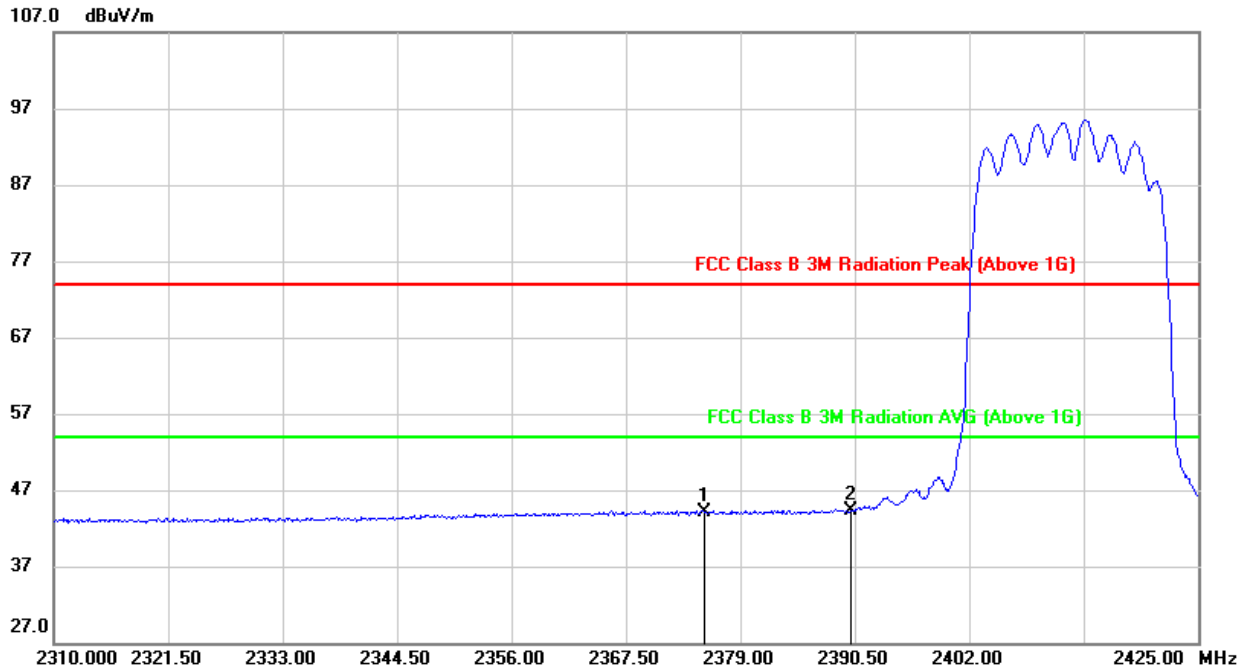

No.	Frequency (MHz)	Reading (dBuV)	Correct (dB/m)	Result (dBuV)	Limit (dBuV)	Margin (dB)	Remark
1	2375.320	11.22	32.90	44.12	54.00	-9.88	AVG
2	2390.000	11.44	32.94	44.38	54.00	-9.62	AVG

- Note:
1. Measurement = Reading Level + Correct Factor.
 2. If Peak Result complies with AV limit, AV Result is deemed to comply with AV limit.
 3. AVG: $VBW=1/T_{on}$ where: t_{on} is transmit duration.
 4. For transmit duration, please refer to clause 8.1.
 5. Only the worst case emission was recorded, if it complies with the limit, the other emissions deemed to comply with the limit.



RESTRICTED BANDEDGE (LOW CHANNEL, VERTICAL)

PEAK

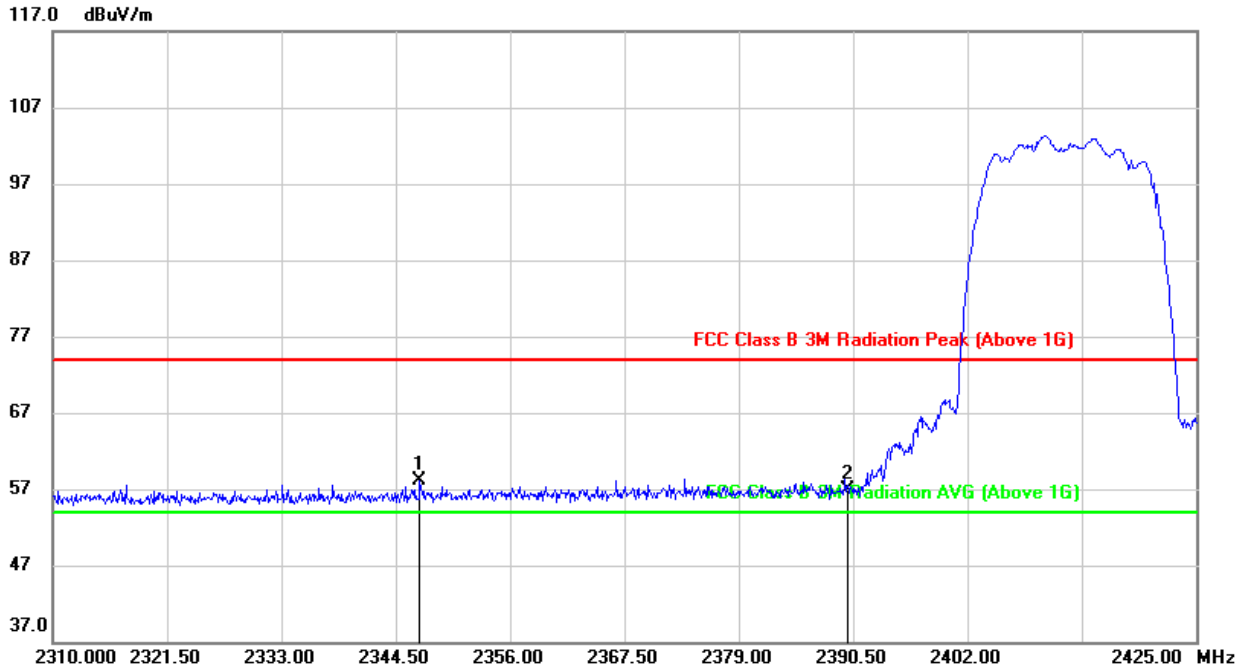

No.	Frequency (MHz)	Reading (dBuV)	Correct (dB/m)	Result (dBuV)	Limit (dBuV)	Margin (dB)	Remark
1	2346.915	25.30	32.79	58.09	74.00	-15.91	peak
2	2390.000	23.88	32.94	56.82	74.00	-17.18	peak

- Note:
1. Measurement = Reading Level + Correct Factor.
 2. If Peak Result complies with AV limit, AV Result is deemed to comply with AV limit.
 3. Peak: Peak detector.
 4. Only the worst case emission was recorded, if it complies with the limit, the other emissions deemed to comply with the limit.



AVG

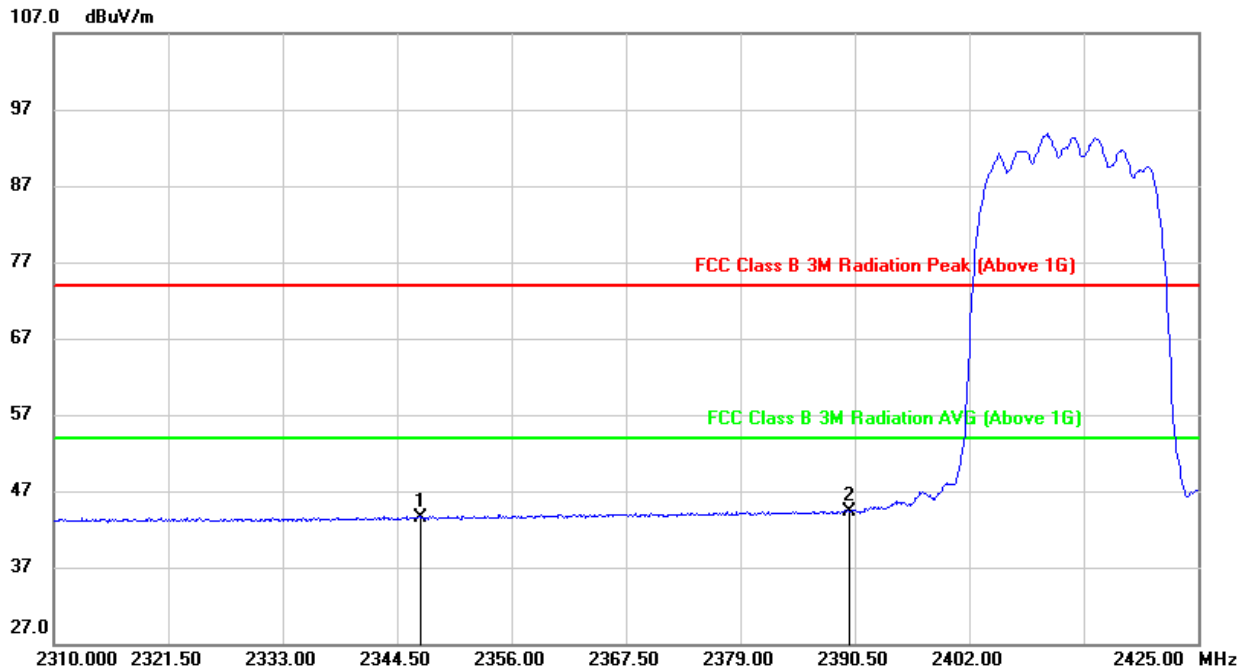

No.	Frequency (MHz)	Reading (dBuV)	Correct (dB/m)	Result (dBuV)	Limit (dBuV)	Margin (dB)	Remark
1	2346.915	10.79	32.79	43.58	54.00	-10.42	AVG
2	2390.000	11.39	32.94	44.33	54.00	-9.67	AVG

- Note:
1. Measurement = Reading Level + Correct Factor.
 2. If Peak Result complies with AV limit, AV Result is deemed to comply with AV limit.
 3. AVG: $VBW=1/T_{on}$ where: t_{on} is transmit duration.
 4. For transmit duration, please refer to clause 8.1.
 5. Only the worst case emission was recorded, if it complies with the limit, the other emissions deemed to comply with the limit.



RESTRICTED BANDEDGE (HIGH CHANNEL, HORIZONTAL)

PEAK

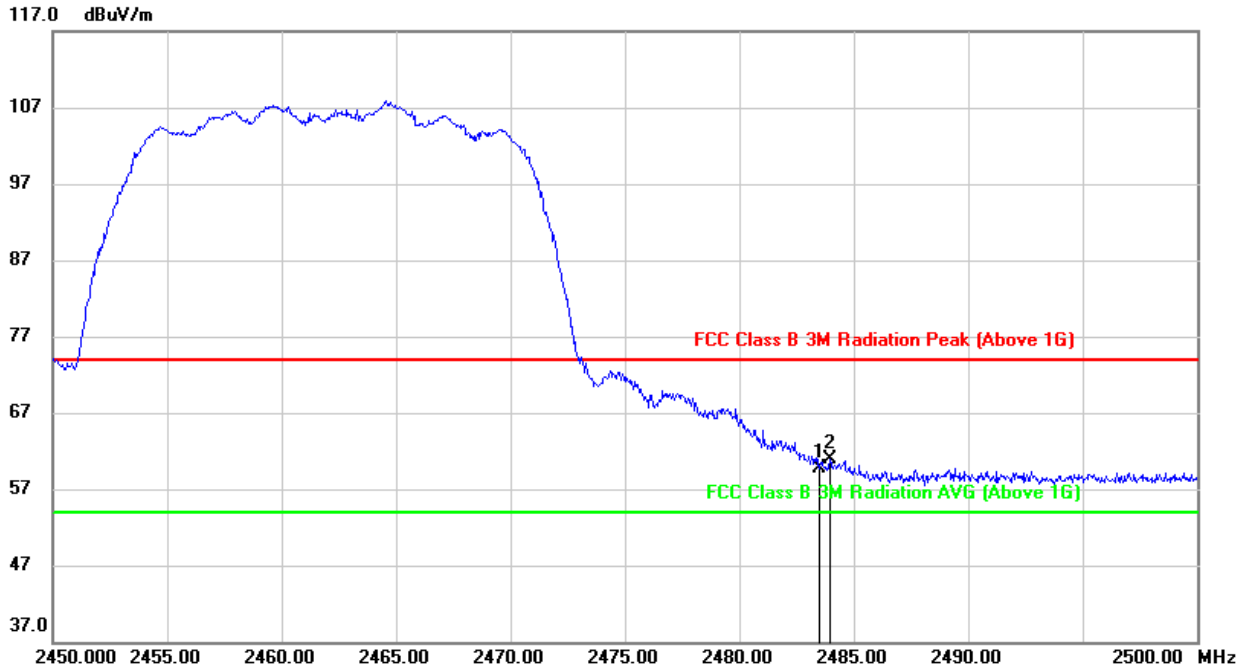

No.	Frequency (MHz)	Reading (dBuV)	Correct (dB/m)	Result (dBuV)	Limit (dBuV)	Margin (dB)	Remark
1	2483.500	26.15	33.58	59.73	74.00	-14.27	peak
2	2483.950	27.25	33.58	60.83	74.00	-13.17	peak

- Note: 1. Measurement = Reading Level + Correct Factor.
 2. If Peak Result complies with AV limit, AV Result is deemed to comply with AV limit.
 3. Peak: Peak detector.
 4. Only the worst case emission was recorded, if it complies with the limit, the other emissions deemed to comply with the limit.



AVG

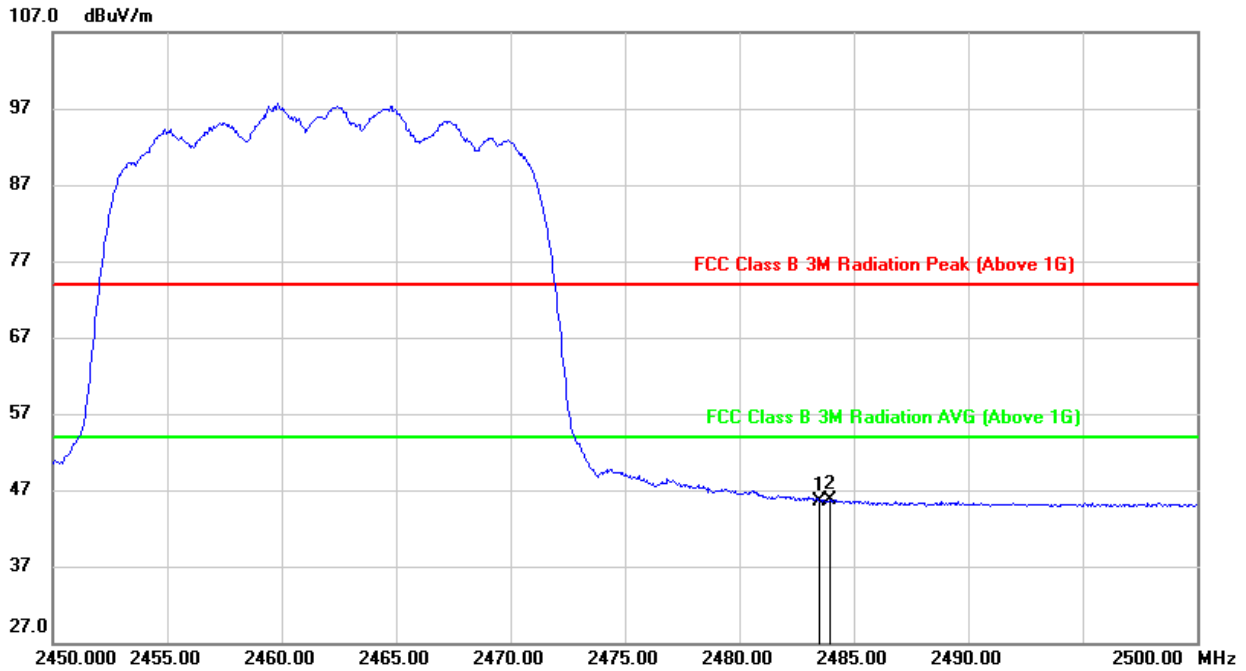

No.	Frequency (MHz)	Reading (dBuV)	Correct (dB/m)	Result (dBuV)	Limit (dBuV)	Margin (dB)	Remark
1	2483.500	11.92	33.58	45.50	54.00	-8.50	AVG
2	2483.950	12.04	33.58	45.62	54.00	-8.38	AVG

- Note: 1. Measurement = Reading Level + Correct Factor.
 2. If Peak Result complies with AV limit, AV Result is deemed to comply with AV limit.
 3. AVG: $VBW=1/T_{on}$ where: t_{on} is transmit duration.
 4. For transmit duration, please refer to clause 8.1.
 5. Only the worst case emission was recorded, if it complies with the limit, the other emissions deemed to comply with the limit.



RESTRICTED BANDEDGE (HIGH CHANNEL, VERTICAL)

PEAK

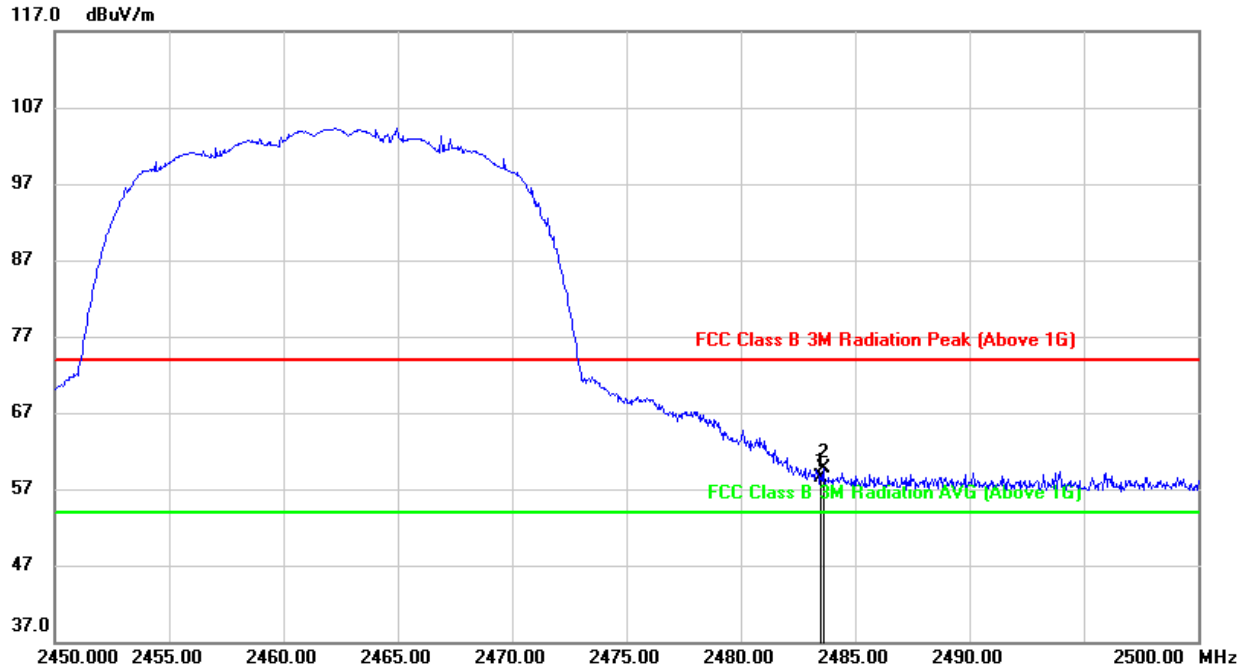

No.	Frequency (MHz)	Reading (dBuV)	Correct (dB/m)	Result (dBuV)	Limit (dBuV)	Margin (dB)	Remark
1	2483.500	24.90	33.58	58.48	74.00	-15.52	peak
2	2483.600	26.03	33.58	59.61	74.00	-14.39	peak

- Note: 1. Measurement = Reading Level + Correct Factor.
 2. If Peak Result complies with AV limit, AV Result is deemed to comply with AV limit.
 3. Peak: Peak detector.
 4. Only the worst case emission was recorded, if it complies with the limit, the other emissions deemed to comply with the limit.



AVG

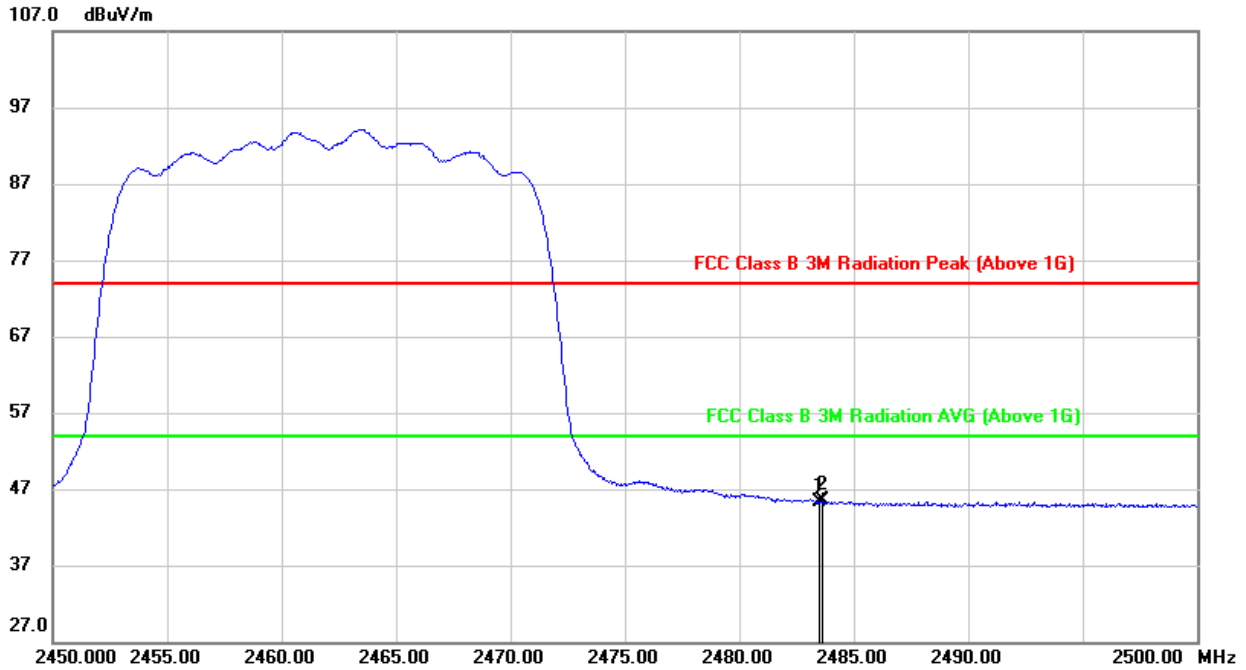

No.	Frequency (MHz)	Reading (dBuV)	Correct (dB/m)	Result (dBuV)	Limit (dBuV)	Margin (dB)	Remark
1	2483.500	11.70	33.58	45.28	54.00	-8.72	AVG
2	2483.600	11.90	33.58	45.48	54.00	-8.52	AVG

- Note:
1. Measurement = Reading Level + Correct Factor.
 2. If Peak Result complies with AV limit, AV Result is deemed to comply with AV limit.
 3. AVG: $VBW=1/T_{on}$ where: t_{on} is transmit duration.
 4. For transmit duration, please refer to clause 8.1.
 5. Only the worst case emission was recorded, if it complies with the limit, the other emissions deemed to comply with the limit.



9.1.4. 802.11n HT40 MIMO MODE

2TX MODE (WORST-CASE CONFIGURATION)

RESTRICTED BANDEDGE (LOW CHANNEL, HORIZONTAL)

PEAK

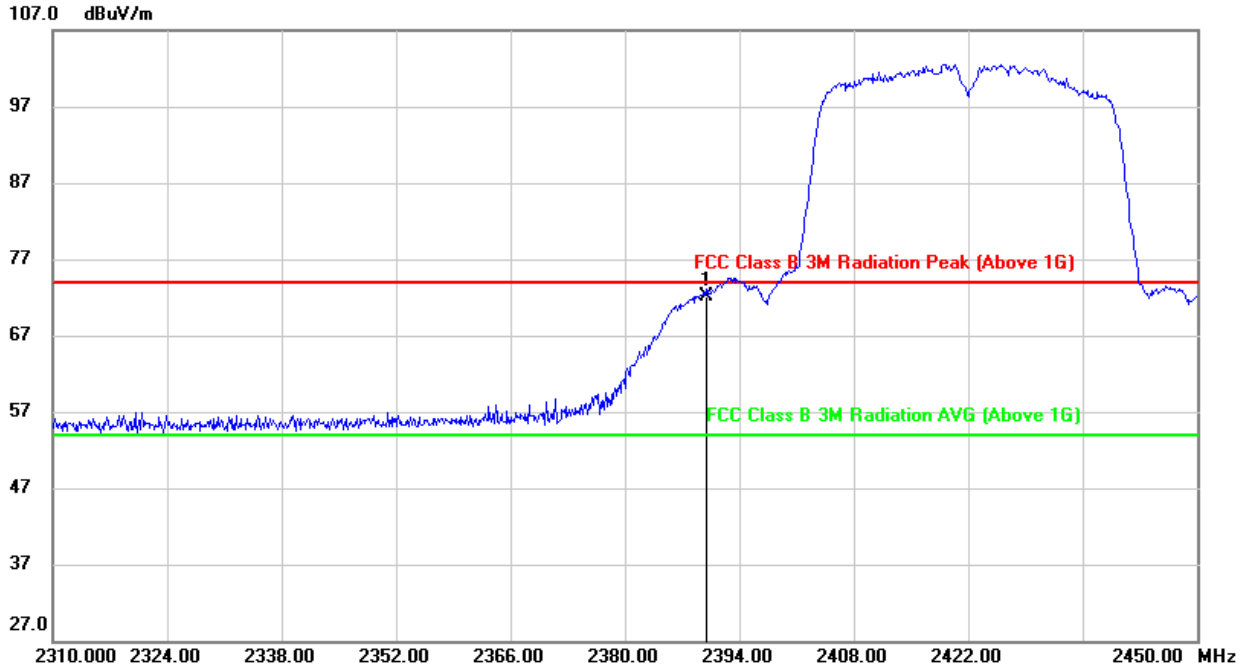

No.	Frequency (MHz)	Reading (dBuV)	Correct (dB/m)	Result (dBuV)	Limit (dBuV)	Margin (dB)	Remark
1	2390.000	39.12	32.94	72.06	74.00	-1.94	peak

- Note: 1. Measurement = Reading Level + Correct Factor.
 2. If Peak Result complies with AV limit, AV Result is deemed to comply with AV limit.
 3. Peak: Peak detector.
 4. Only the worst case emission was recorded, if it complies with the limit, the other emissions deemed to comply with the limit.



AVG

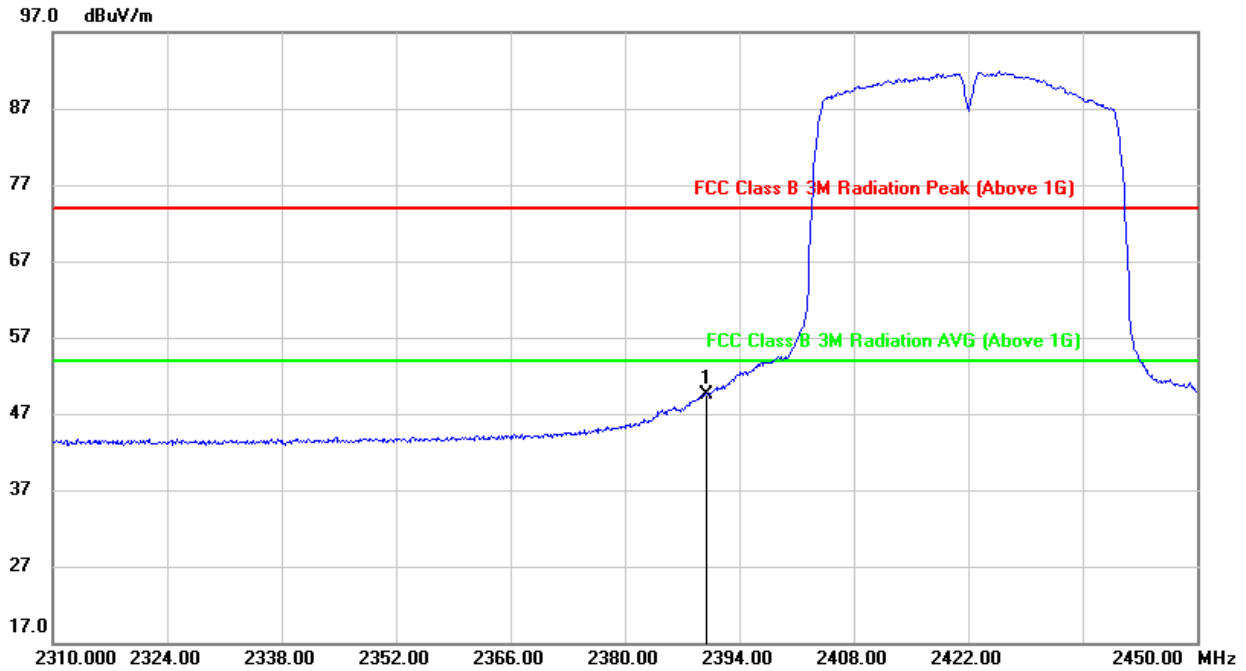

No.	Frequency (MHz)	Reading (dBuV)	Correct (dB/m)	Result (dBuV)	Limit (dBuV)	Margin (dB)	Remark
1	2390.000	16.62	32.94	49.56	54.00	-4.44	AVG

- Note:
1. Measurement = Reading Level + Correct Factor.
 2. If Peak Result complies with AV limit, AV Result is deemed to comply with AV limit.
 3. AVG: $VBW=1/T_{on}$ where: t_{on} is transmit duration.
 4. For transmit duration, please refer to clause 8.1.
 5. Only the worst case emission was recorded, if it complies with the limit, the other emissions deemed to comply with the limit.



RESTRICTED BANDEDGE (LOW CHANNEL, VERTICAL)

PEAK

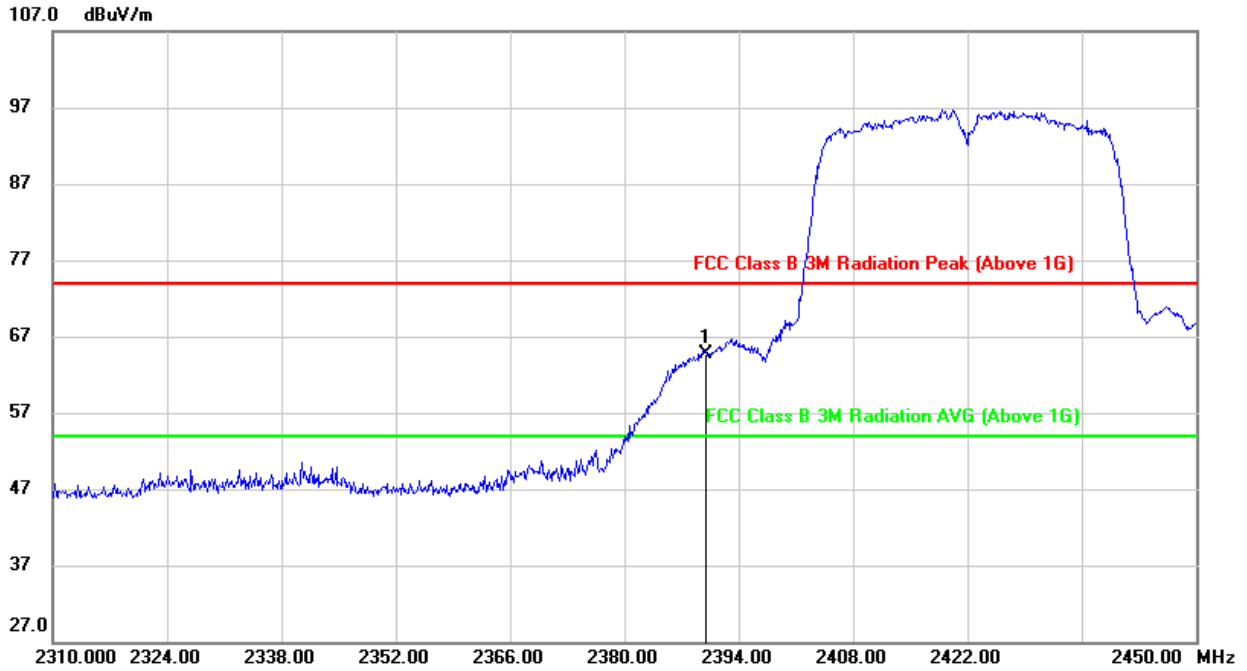

No.	Frequency (MHz)	Reading (dBuV)	Correct (dB/m)	Result (dBuV)	Limit (dBuV)	Margin (dB)	Remark
1	2390.000	31.80	32.94	64.74	74.00	-9.26	peak

- Note:
1. Measurement = Reading Level + Correct Factor.
 2. If Peak Result complies with AV limit, AV Result is deemed to comply with AV limit.
 3. Peak: Peak detector.
 4. Only the worst case emission was recorded, if it complies with the limit, the other emissions deemed to comply with the limit.



AVG

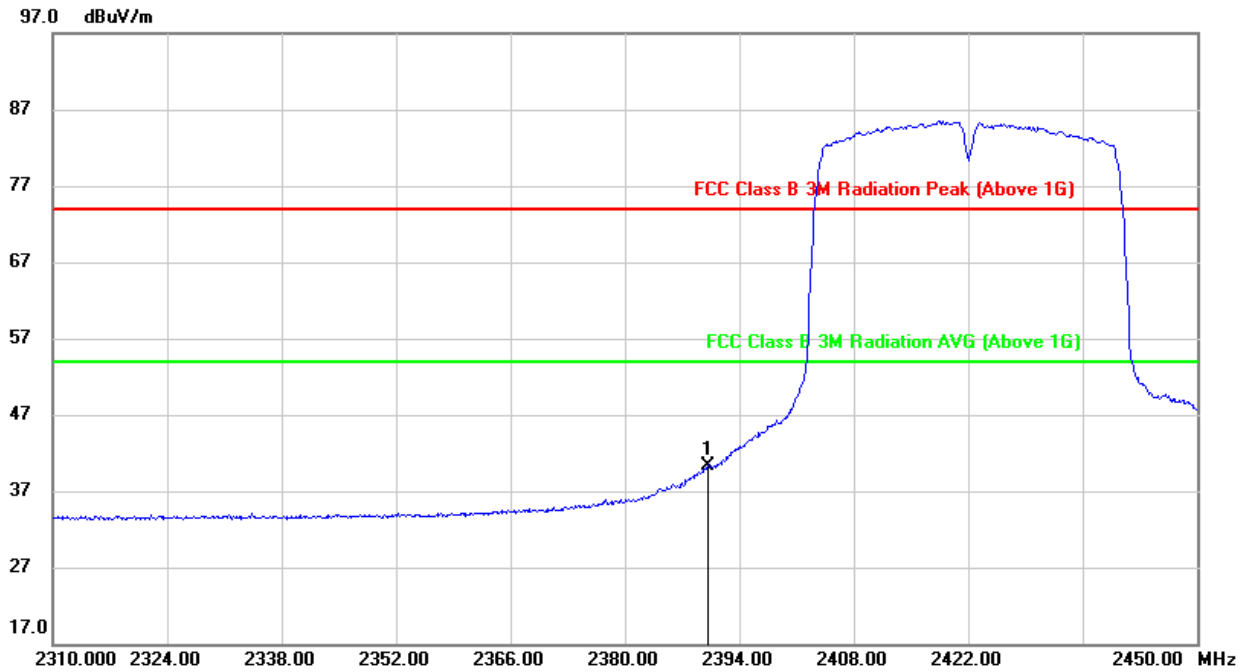

No.	Frequency (MHz)	Reading (dBuV)	Correct (dB/m)	Result (dBuV)	Limit (dBuV)	Margin (dB)	Remark
1	2390.000	7.42	32.94	40.36	54.00	-13.64	AVG

- Note:
1. Measurement = Reading Level + Correct Factor.
 2. If Peak Result complies with AV limit, AV Result is deemed to comply with AV limit.
 3. AVG: $VBW=1/T_{on}$ where: t_{on} is transmit duration.
 4. For transmit duration, please refer to clause 8.1.
 5. Only the worst case emission was recorded, if it complies with the limit, the other emissions deemed to comply with the limit.



RESTRICTED BANDEDGE (HIGH CHANNEL, HORIZONTAL)

PEAK

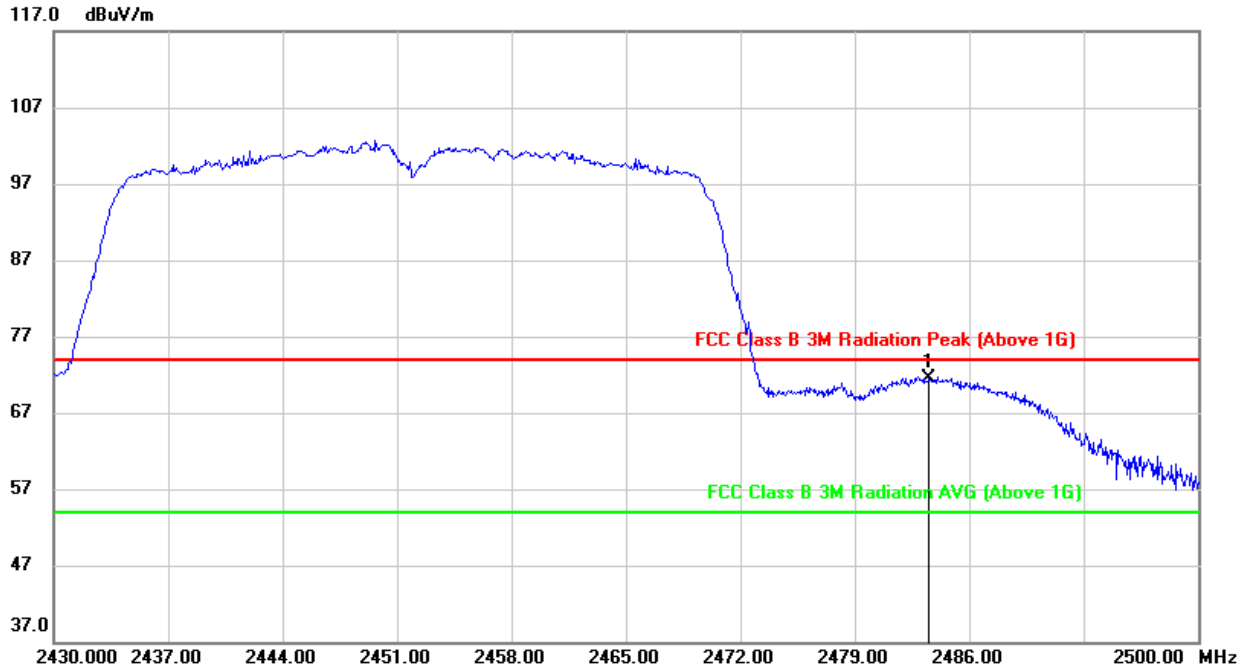

No.	Frequency (MHz)	Reading (dBuV)	Correct (dB/m)	Result (dBuV)	Limit (dBuV)	Margin (dB)	Remark
1	2483.500	37.83	33.58	71.41	74.00	-2.59	peak

- Note: 1. Measurement = Reading Level + Correct Factor.
 2. If Peak Result complies with AV limit, AV Result is deemed to comply with AV limit.
 3. Peak: Peak detector.
 4. Only the worst case emission was recorded, if it complies with the limit, the other emissions deemed to comply with the limit.



AVG

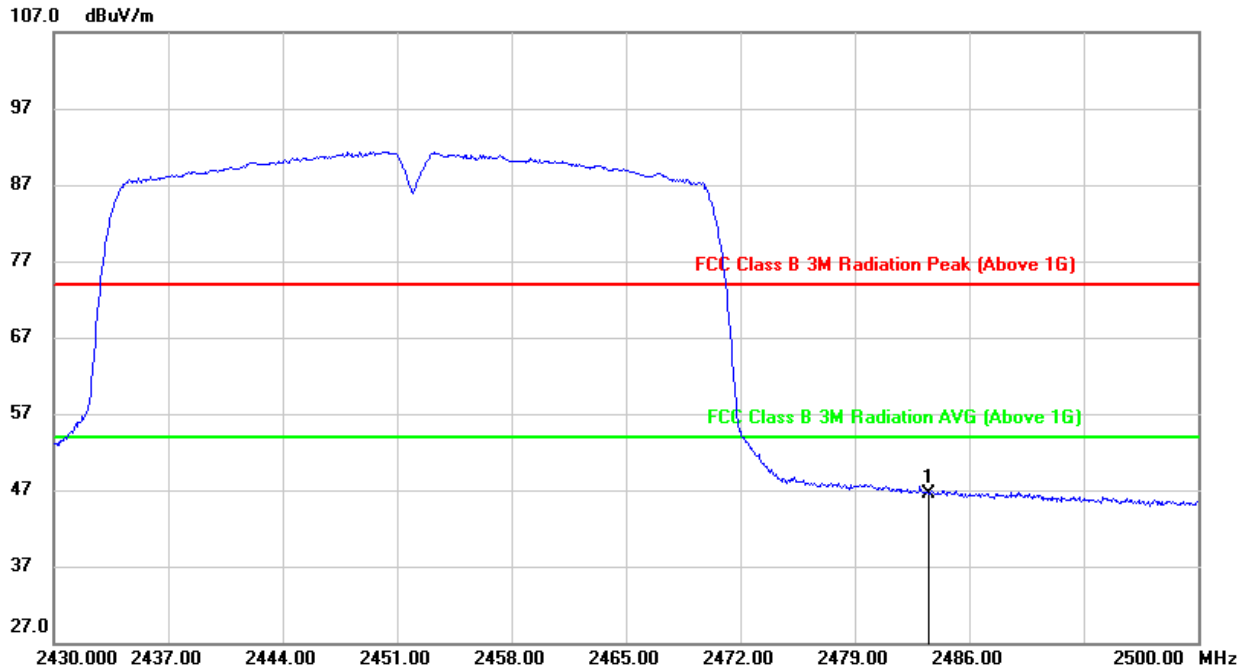

No.	Frequency (MHz)	Reading (dBuV)	Correct (dB/m)	Result (dBuV)	Limit (dBuV)	Margin (dB)	Remark
1	2483.500	12.94	33.58	46.52	54.00	-7.48	AVG

- Note:
1. Measurement = Reading Level + Correct Factor.
 2. If Peak Result complies with AV limit, AV Result is deemed to comply with AV limit.
 3. AVG: $VBW=1/T_{on}$ where: t_{on} is transmit duration.
 4. For transmit duration, please refer to clause 8.1.
 5. Only the worst case emission was recorded, if it complies with the limit, the other emissions deemed to comply with the limit.



RESTRICTED BANDEDGE (HIGH CHANNEL, VERTICAL)

PEAK

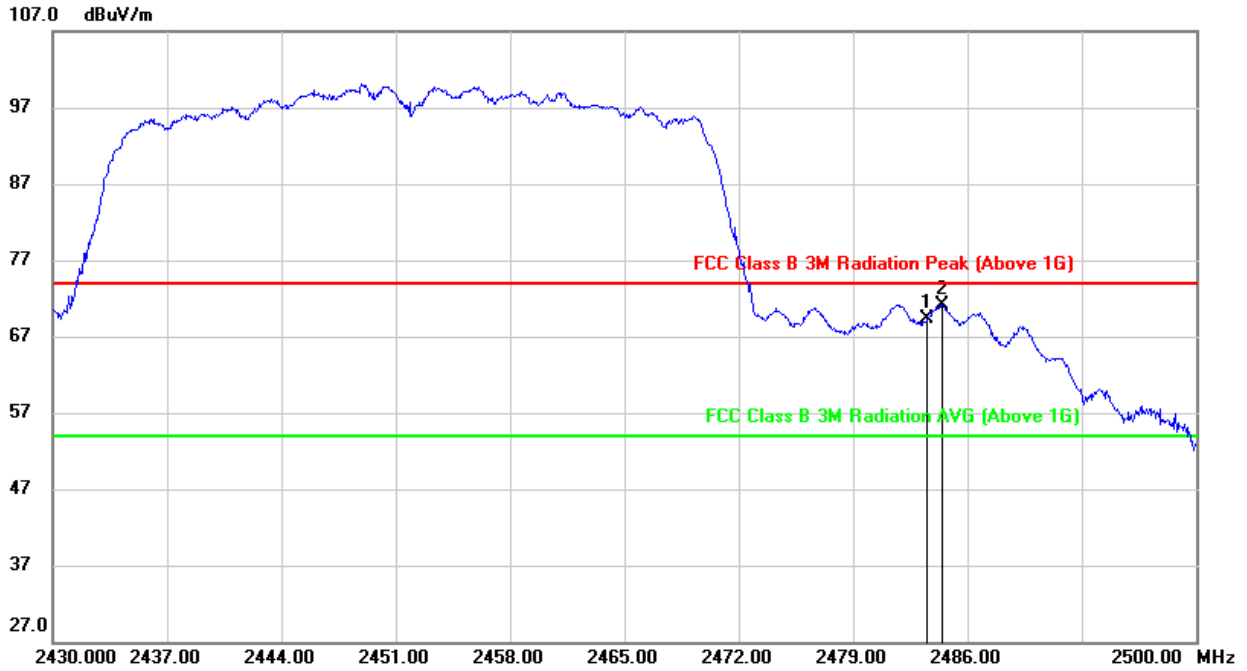

No.	Frequency (MHz)	Reading (dBuV)	Correct (dB/m)	Result (dBuV)	Limit (dBuV)	Margin (dB)	Remark
1	2483.500	35.71	33.58	69.29	74.00	-4.71	peak
2	2484.460	37.55	33.59	71.14	74.00	-2.86	peak

- Note: 1. Measurement = Reading Level + Correct Factor.
 2. If Peak Result complies with AV limit, AV Result is deemed to comply with AV limit.
 3. Peak: Peak detector.
 4. Only the worst case emission was recorded, if it complies with the limit, the other emissions deemed to comply with the limit.



AVG

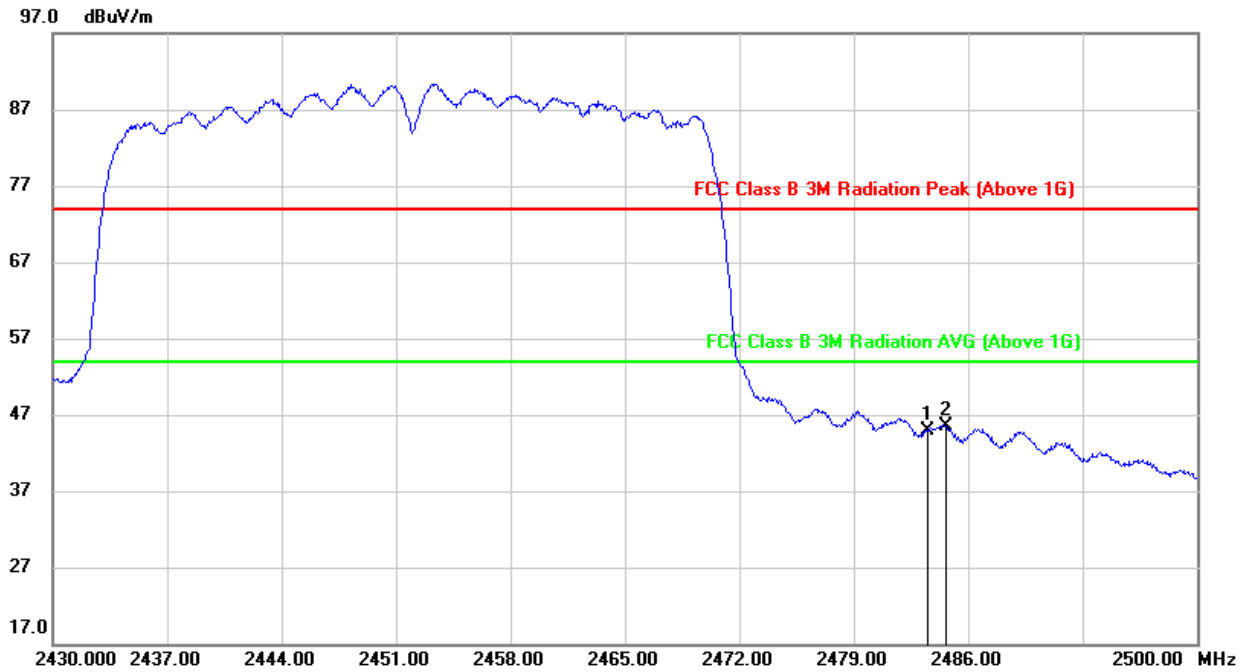

No.	Frequency (MHz)	Reading (dBuV)	Correct (dB/m)	Result (dBuV)	Limit (dBuV)	Margin (dB)	Remark
1	2483.500	11.30	33.58	44.88	54.00	-9.12	AVG
2	2484.600	11.86	33.59	45.45	54.00	-8.55	AVG

- Note:
1. Measurement = Reading Level + Correct Factor.
 2. If Peak Result complies with AV limit, AV Result is deemed to comply with AV limit.
 3. AVG: $VBW=1/T_{on}$ where: t_{on} is transmit duration.
 4. For transmit duration, please refer to clause 8.1.
 5. Only the worst case emission was recorded, if it complies with the limit, the other emissions deemed to comply with the limit.



9.2. SPURIOUS EMISSIONS (3~18GHz)

9.2.1. 802.11b SISO MODE

1TX MODE FOR ANT1 (WORST-CASE CONFIGURATION)

HARMONICS AND SPURIOUS EMISSIONS (LOW CHANNEL, HORIZONTAL)

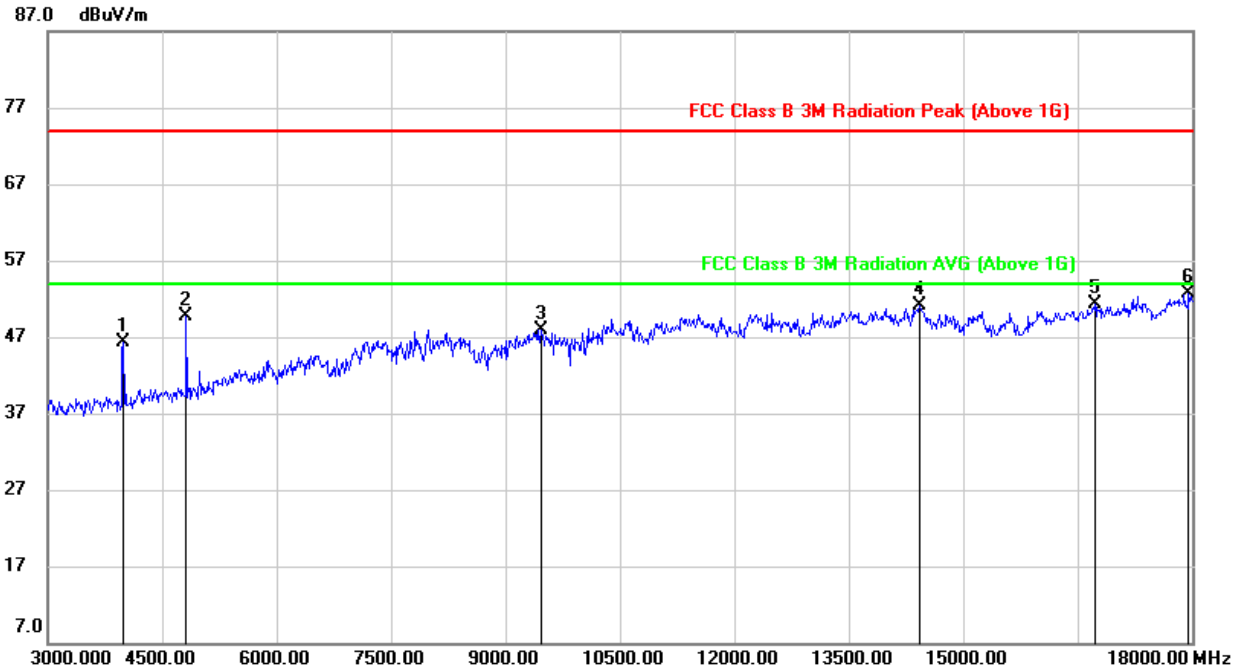

No.	Frequency (MHz)	Reading (dBuV)	Correct (dB/m)	Result (dBuV)	Limit (dBuV)	Margin (dB)	Remark
1	3990.000	49.31	-2.95	46.36	74.00	-27.64	peak
2	4815.000	49.90	-0.23	49.67	74.00	-24.33	peak
3	9465.000	37.49	10.41	47.90	74.00	-26.10	peak
4	14430.000	34.66	16.39	51.05	74.00	-22.95	peak
5	16725.000	31.50	19.85	51.35	74.00	-22.65	peak
6	17955.000	29.48	23.23	52.71	74.00	-21.29	peak

- Note: 1. Measurement = Reading Level + Correct Factor.
 2. If Peak Result complies with AV limit, AV Result is deemed to comply with AV limit.
 3. Peak: Peak detector.
 4. The High Pass filter loss factor already add into the correct factor.
 5. Proper operation of the transmitter prior to adding the filter to the measurement chain.



HARMONICS AND SPURIOUS EMISSIONS (LOW CHANNEL, VERTICAL)

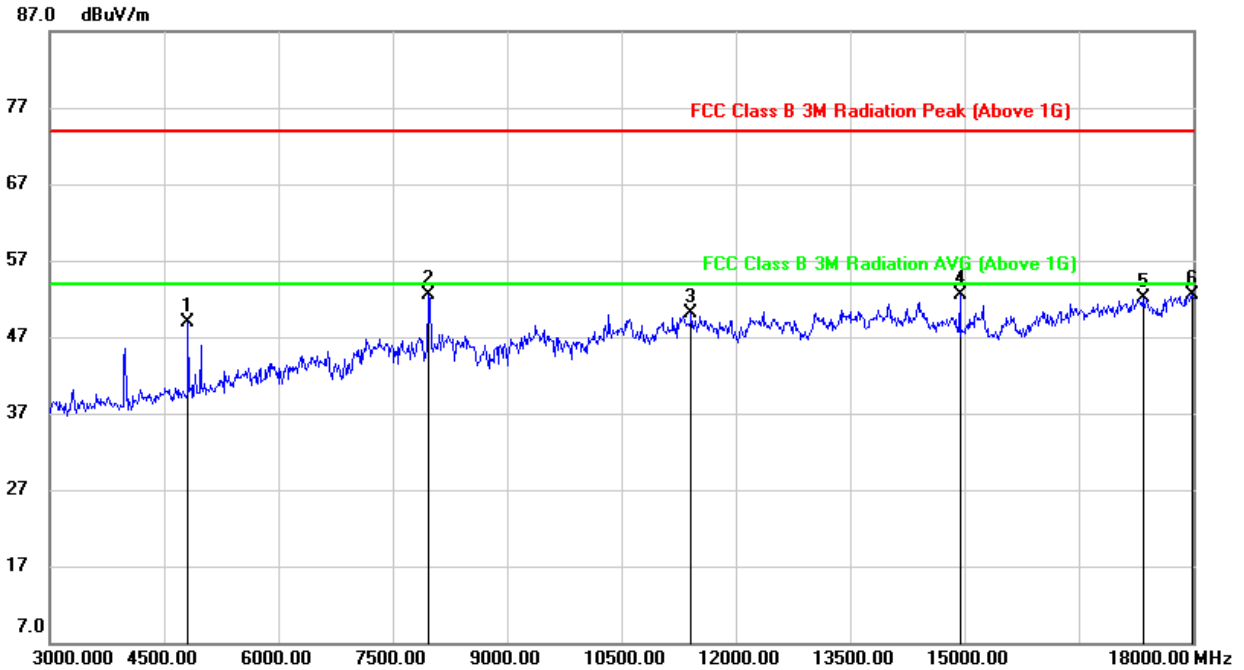

No.	Frequency (MHz)	Reading (dBuV)	Correct (dB/m)	Result (dBuV)	Limit (dBuV)	Margin (dB)	Remark
1	4815.000	49.13	-0.23	48.90	74.00	-25.10	peak
2	7965.000	44.32	8.26	52.58	74.00	-21.42	peak
3	11415.000	36.55	13.46	50.01	74.00	-23.99	peak
4	14940.000	36.92	15.50	52.42	74.00	-21.58	peak
5	17340.000	30.34	21.73	52.07	74.00	-21.93	peak
6	17985.000	29.20	23.25	52.45	74.00	-21.55	peak

- Note: 1. Measurement = Reading Level + Correct Factor.
 2. If Peak Result complies with AV limit, AV Result is deemed to comply with AV limit.
 3. Peak: Peak detector.
 4. The High Pass filter loss factor already add into the correct factor.
 5. Proper operation of the transmitter prior to adding the filter to the measurement chain.



HARMONICS AND SPURIOUS EMISSIONS (MID CHANNEL, HORIZONTAL)

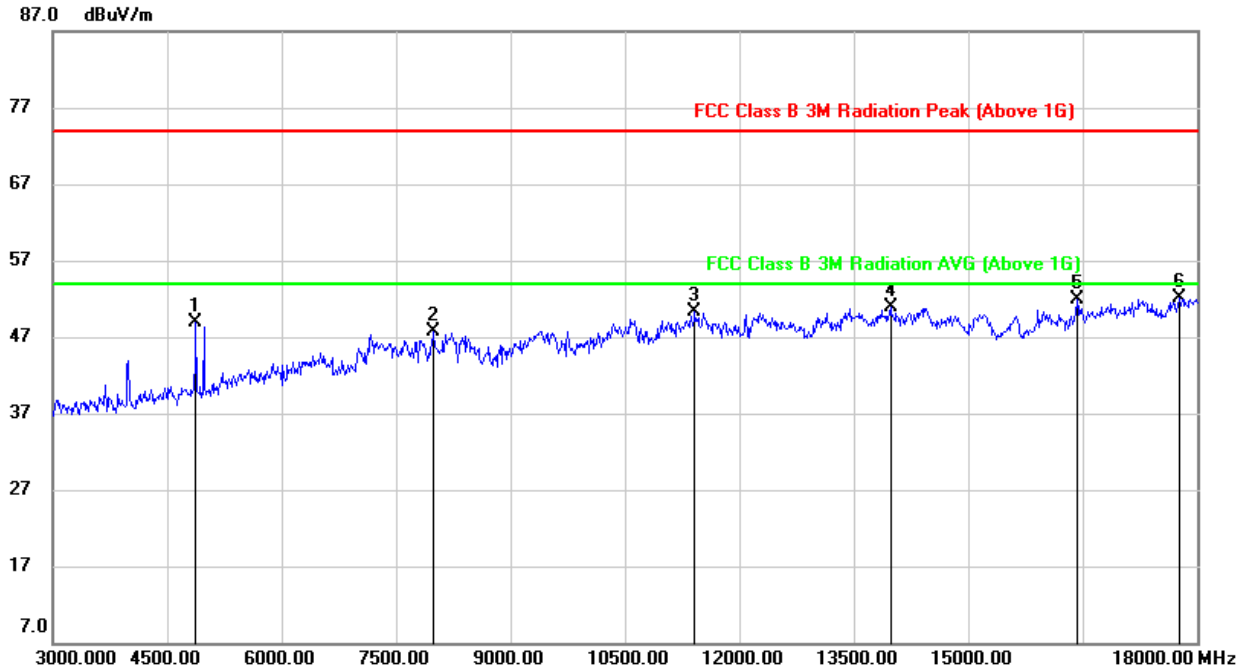

No.	Frequency (MHz)	Reading (dBuV)	Correct (dB/m)	Result (dBuV)	Limit (dBuV)	Margin (dB)	Remark
1	4875.000	48.93	-0.12	48.81	74.00	-25.19	peak
2	7995.000	39.45	8.16	47.61	74.00	-26.39	peak
3	11415.000	36.76	13.46	50.22	74.00	-23.78	peak
4	13980.000	34.63	16.32	50.95	74.00	-23.05	peak
5	16425.000	33.19	18.65	51.84	74.00	-22.16	peak
6	17775.000	29.09	22.97	52.06	74.00	-21.94	peak

- Note: 1. Measurement = Reading Level + Correct Factor.
 2. If Peak Result complies with AV limit, AV Result is deemed to comply with AV limit.
 3. Peak: Peak detector.
 4. The High Pass filter loss factor already add into the correct factor.
 5. Proper operation of the transmitter prior to adding the filter to the measurement chain.



HARMONICS AND SPURIOUS EMISSIONS (MID CHANNEL, VERTICAL)

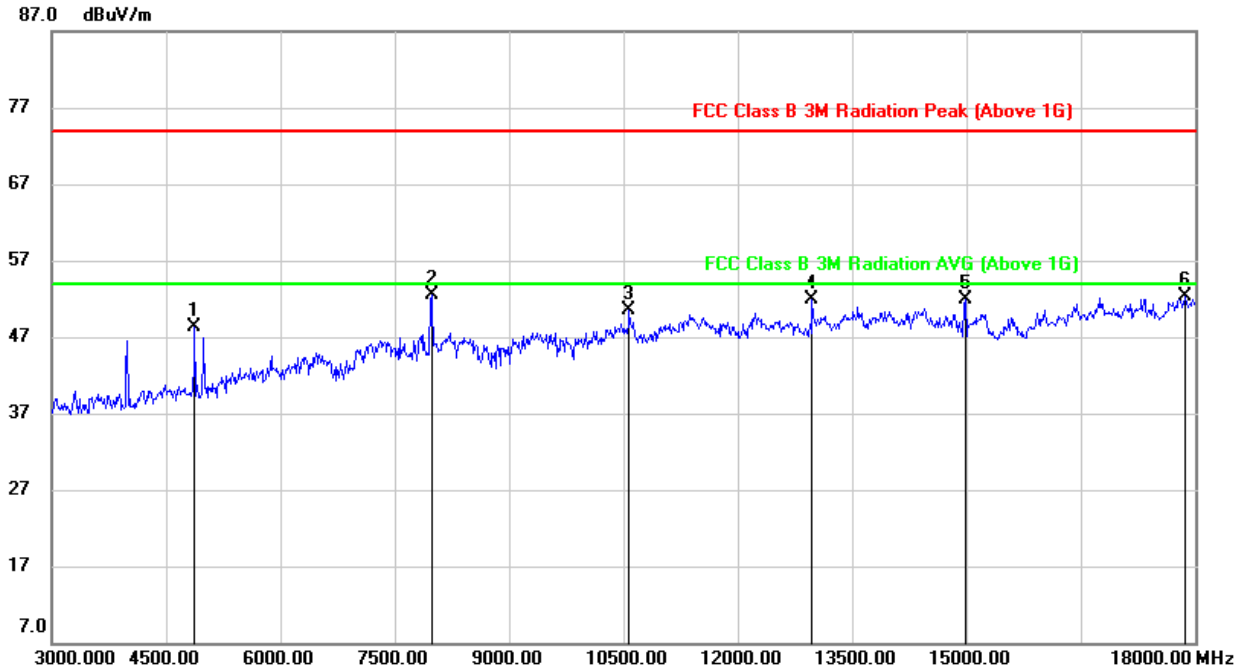

No.	Frequency (MHz)	Reading (dBuV)	Correct (dB/m)	Result (dBuV)	Limit (dBuV)	Margin (dB)	Remark
1	4875.000	48.45	-0.12	48.33	74.00	-25.67	peak
2	7980.000	44.33	8.20	52.53	74.00	-21.47	peak
3	10575.000	37.93	12.52	50.45	74.00	-23.55	peak
4	12975.000	37.15	14.71	51.86	74.00	-22.14	peak
5	14985.000	36.47	15.47	51.94	74.00	-22.06	peak
6	17865.000	29.09	23.19	52.28	74.00	-21.72	peak

- Note: 1. Measurement = Reading Level + Correct Factor.
 2. If Peak Result complies with AV limit, AV Result is deemed to comply with AV limit.
 3. Peak: Peak detector.
 4. The High Pass filter loss factor already add into the correct factor.
 5. Proper operation of the transmitter prior to adding the filter to the measurement chain.



HARMONICS AND SPURIOUS EMISSIONS (HIGH CHANNEL, HORIZONTAL)

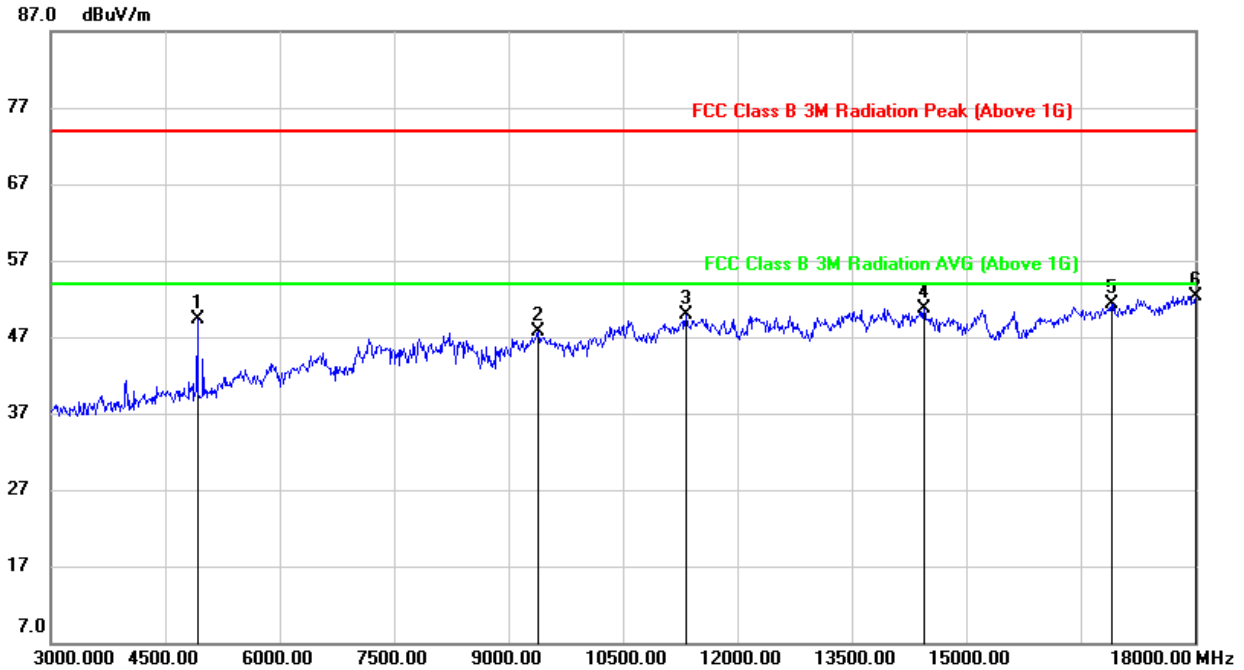

No.	Frequency (MHz)	Reading (dBuV)	Correct (dB/m)	Result (dBuV)	Limit (dBuV)	Margin (dB)	Remark
1	4920.000	49.33	0.02	49.35	74.00	-24.65	peak
2	9390.000	37.38	10.24	47.62	74.00	-26.38	peak
3	11325.000	36.83	13.02	49.85	74.00	-24.15	peak
4	14445.000	34.37	16.37	50.74	74.00	-23.26	peak
5	16905.000	31.36	19.95	51.31	74.00	-22.69	peak
6	18000.000	29.07	23.27	52.34	74.00	-21.66	peak

- Note: 1. Measurement = Reading Level + Correct Factor.
 2. If Peak Result complies with AV limit, AV Result is deemed to comply with AV limit.
 3. Peak: Peak detector.
 4. The High Pass filter loss factor already add into the correct factor.
 5. Proper operation of the transmitter prior to adding the filter to the measurement chain.



HARMONICS AND SPURIOUS EMISSIONS (HIGH CHANNEL, VERTICAL)

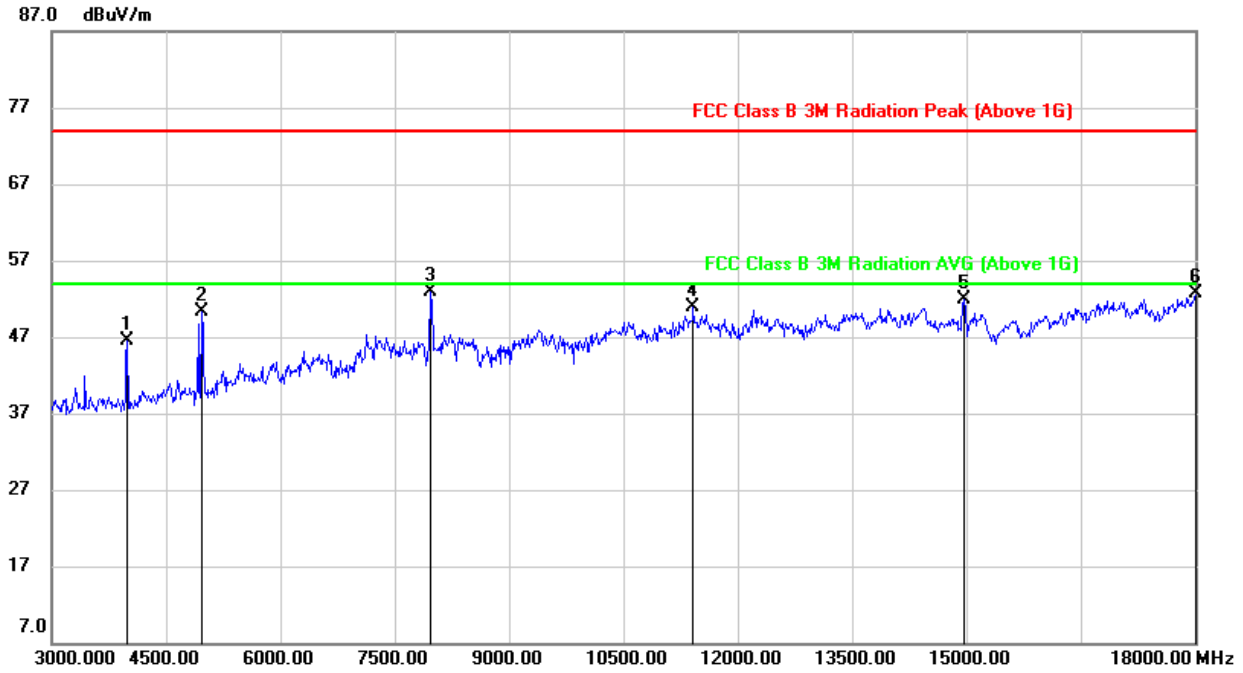

No.	Frequency (MHz)	Reading (dBuV)	Correct (dB/m)	Result (dBuV)	Limit (dBuV)	Margin (dB)	Remark
1	3990.000	49.40	-2.95	46.45	74.00	-27.55	peak
2	4965.000	49.99	0.28	50.27	74.00	-23.73	peak
3	7965.000	44.58	8.26	52.84	74.00	-21.16	peak
4	11415.000	37.44	13.46	50.90	74.00	-23.10	peak
5	14970.000	36.42	15.48	51.90	74.00	-22.10	peak
6	18000.000	29.49	23.27	52.76	74.00	-21.24	peak

- Note: 1. Measurement = Reading Level + Correct Factor.
 2. If Peak Result complies with AV limit, AV Result is deemed to comply with AV limit.
 3. Peak: Peak detector.
 4. The High Pass filter loss factor already add into the correct factor.
 5. Proper operation of the transmitter prior to adding the filter to the measurement chain.



9.2.2. 802.11g SISO MODE

1TX MODE FOR ANT1 (WORST-CASE CONFIGURATION)

HARMONICS AND SPURIOUS EMISSIONS (LOW CHANNEL, HORIZONTAL)

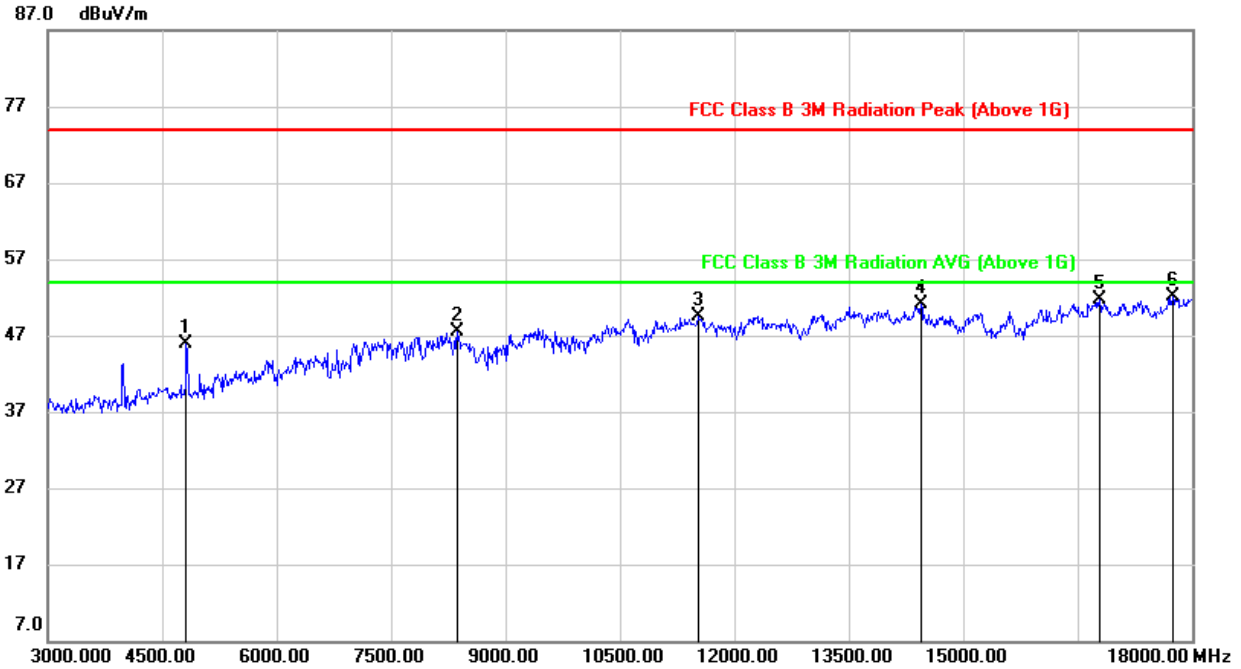

No.	Frequency (MHz)	Reading (dBuV)	Correct (dB/m)	Result (dBuV)	Limit (dBuV)	Margin (dB)	Remark
1	4815.000	46.18	-0.23	45.95	74.00	-28.05	peak
2	8370.000	38.82	8.66	47.48	74.00	-26.52	peak
3	11535.000	35.39	14.10	49.49	74.00	-24.51	peak
4	14445.000	34.72	16.37	51.09	74.00	-22.91	peak
5	16785.000	31.72	19.90	51.62	74.00	-22.38	peak
6	17745.000	29.44	22.68	52.12	74.00	-21.88	peak

- Note:
1. Measurement = Reading Level + Correct Factor.
 2. If Peak Result complies with AV limit, AV Result is deemed to comply with AV limit.
 3. Peak: Peak detector.
 4. The High Pass filter loss factor already add into the correct factor.
 5. Proper operation of the transmitter prior to adding the filter to the measurement chain.



HARMONICS AND SPURIOUS EMISSIONS (LOW CHANNEL, VERTICAL)

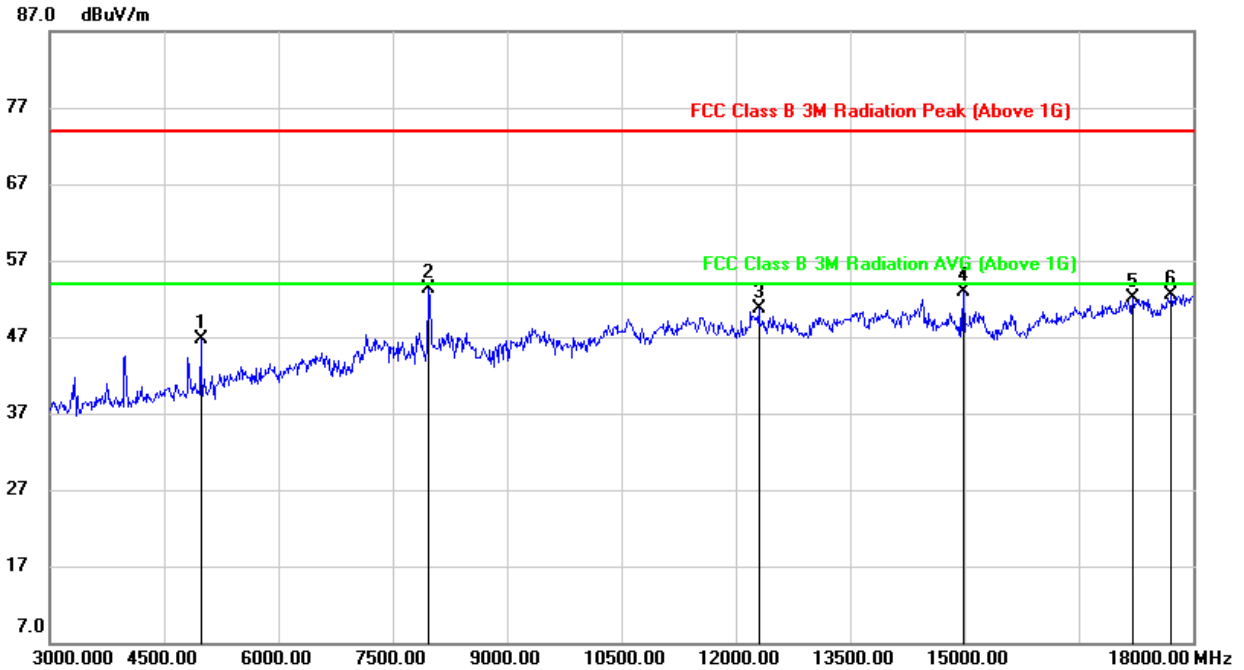

No.	Frequency (MHz)	Reading (dBuV)	Correct (dB/m)	Result (dBuV)	Limit (dBuV)	Margin (dB)	Remark
1	4980.000	46.24	0.37	46.61	74.00	-27.39	peak
2	7965.000	44.96	8.26	53.22	74.00	-20.78	peak
3	12300.000	36.33	14.39	50.72	74.00	-23.28	peak
4	14985.000	37.39	15.47	52.86	74.00	-21.14	peak
5	17205.000	30.97	21.05	52.02	74.00	-21.98	peak
6	17715.000	30.16	22.39	52.55	74.00	-21.45	peak

- Note: 1. Measurement = Reading Level + Correct Factor.
 2. If Peak Result complies with AV limit, AV Result is deemed to comply with AV limit.
 3. Peak: Peak detector.
 4. The High Pass filter loss factor already add into the correct factor.
 5. Proper operation of the transmitter prior to adding the filter to the measurement chain.



HARMONICS AND SPURIOUS EMISSIONS (MID CHANNEL, HORIZONTAL)

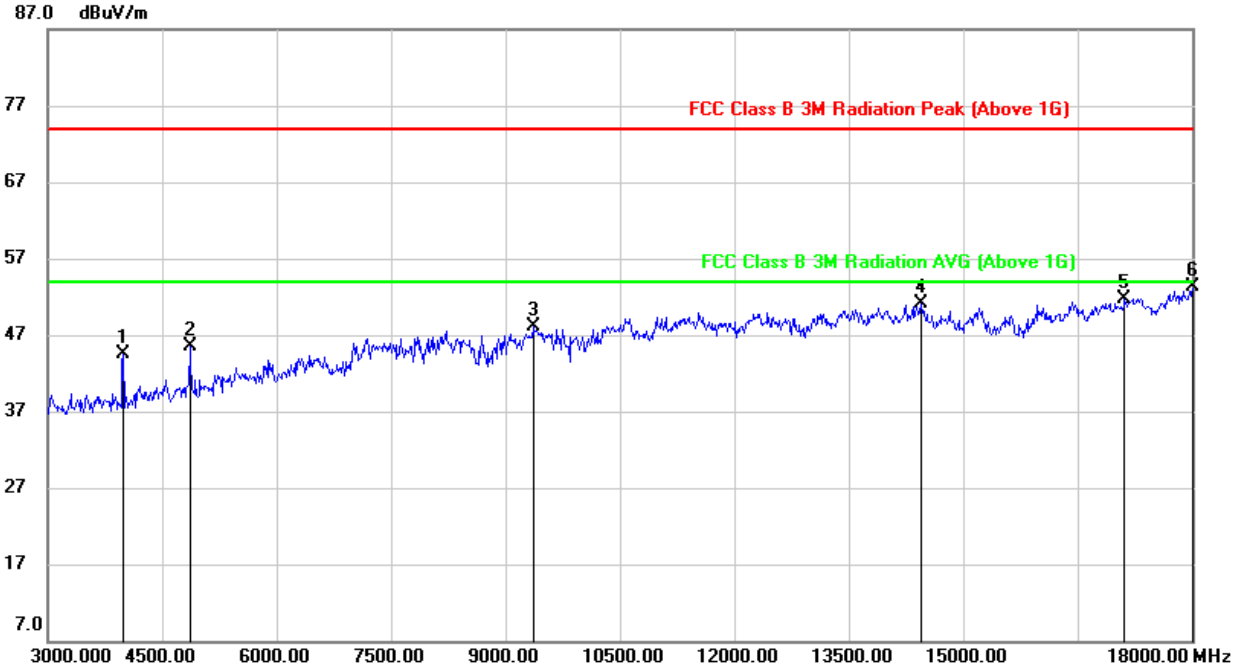

No.	Frequency (MHz)	Reading (dBuV)	Correct (dB/m)	Result (dBuV)	Limit (dBuV)	Margin (dB)	Remark
1	3990.000	47.47	-2.95	44.52	74.00	-29.48	peak
2	4860.000	45.71	-0.15	45.56	74.00	-28.44	peak
3	9360.000	38.14	10.05	48.19	74.00	-25.81	peak
4	14445.000	34.75	16.37	51.12	74.00	-22.88	peak
5	17115.000	30.98	20.81	51.79	74.00	-22.21	peak
6	18000.000	29.95	23.27	53.22	74.00	-20.78	peak

- Note: 1. Measurement = Reading Level + Correct Factor.
 2. If Peak Result complies with AV limit, AV Result is deemed to comply with AV limit.
 3. Peak: Peak detector.
 4. The High Pass filter loss factor already add into the correct factor.
 5. Proper operation of the transmitter prior to adding the filter to the measurement chain.



HARMONICS AND SPURIOUS EMISSIONS (MID CHANNEL, VERTICAL)

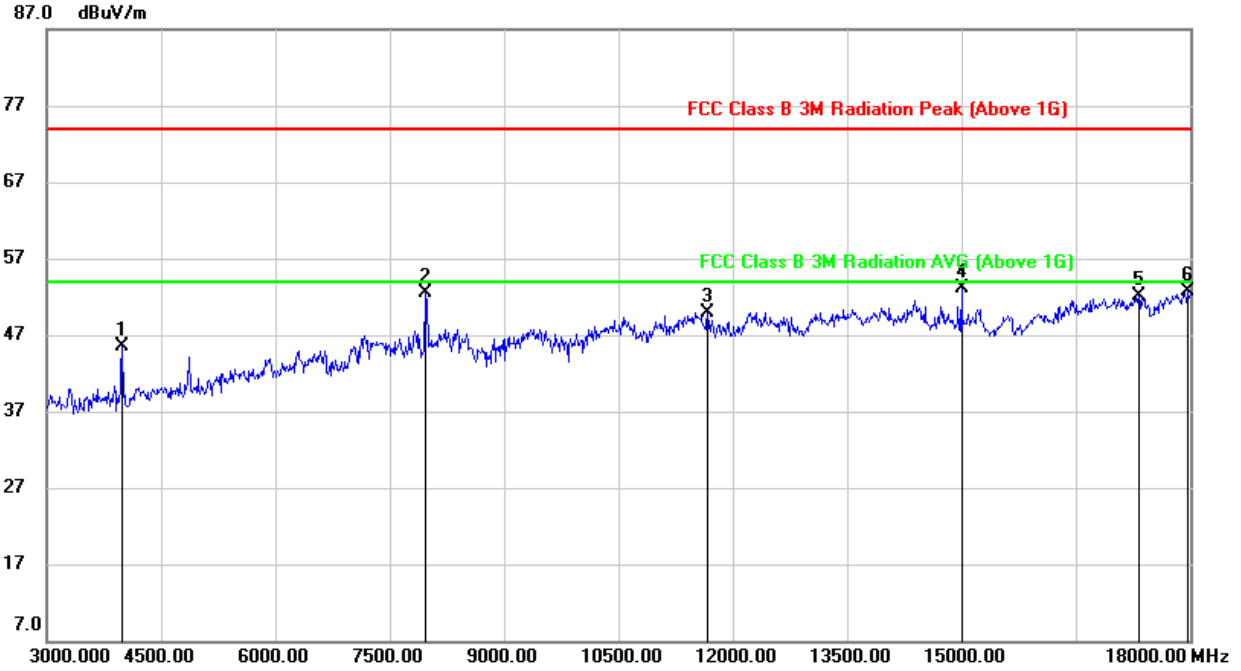

No.	Frequency (MHz)	Reading (dBuV)	Correct (dB/m)	Result (dBuV)	Limit (dBuV)	Margin (dB)	Remark
1	3990.000	48.52	-2.95	45.57	74.00	-28.43	peak
2	7965.000	44.31	8.26	52.57	74.00	-21.43	peak
3	11670.000	36.02	13.80	49.82	74.00	-24.18	peak
4	15000.000	37.62	15.47	53.09	74.00	-20.91	peak
5	17325.000	30.32	21.80	52.12	74.00	-21.88	peak
6	17970.000	29.37	23.24	52.61	74.00	-21.39	peak

- Note: 1. Measurement = Reading Level + Correct Factor.
 2. If Peak Result complies with AV limit, AV Result is deemed to comply with AV limit.
 3. Peak: Peak detector.
 4. The High Pass filter loss factor already add into the correct factor.
 5. Proper operation of the transmitter prior to adding the filter to the measurement chain.



HARMONICS AND SPURIOUS EMISSIONS (HIGH CHANNEL, HORIZONTAL)

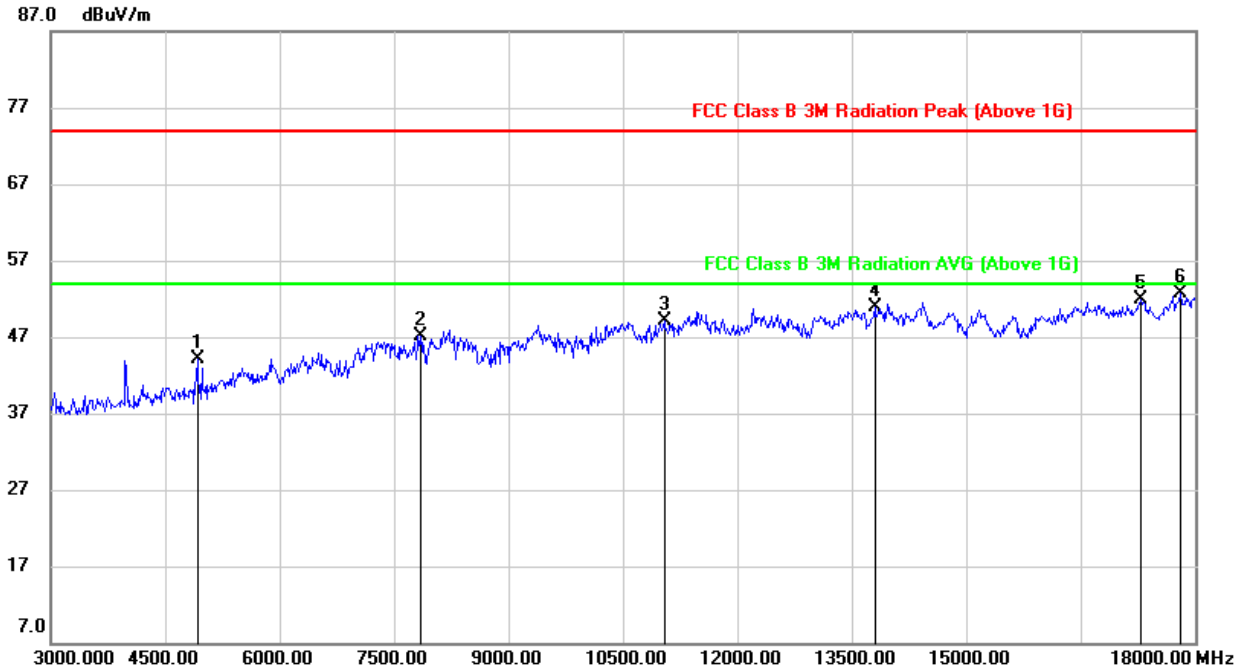

No.	Frequency (MHz)	Reading (dBuV)	Correct (dB/m)	Result (dBuV)	Limit (dBuV)	Margin (dB)	Remark
1	4920.000	43.99	0.02	44.01	74.00	-29.99	peak
2	7845.000	38.41	8.68	47.09	74.00	-26.91	peak
3	11040.000	35.82	13.27	49.09	74.00	-24.91	peak
4	13800.000	34.15	16.81	50.96	74.00	-23.04	peak
5	17295.000	30.04	21.86	51.90	74.00	-22.10	peak
6	17805.000	29.41	23.22	52.63	74.00	-21.37	peak

- Note: 1. Measurement = Reading Level + Correct Factor.
 2. If Peak Result complies with AV limit, AV Result is deemed to comply with AV limit.
 3. Peak: Peak detector.
 4. The High Pass filter loss factor already add into the correct factor.
 5. Proper operation of the transmitter prior to adding the filter to the measurement chain.



HARMONICS AND SPURIOUS EMISSIONS (HIGH CHANNEL, VERTICAL)

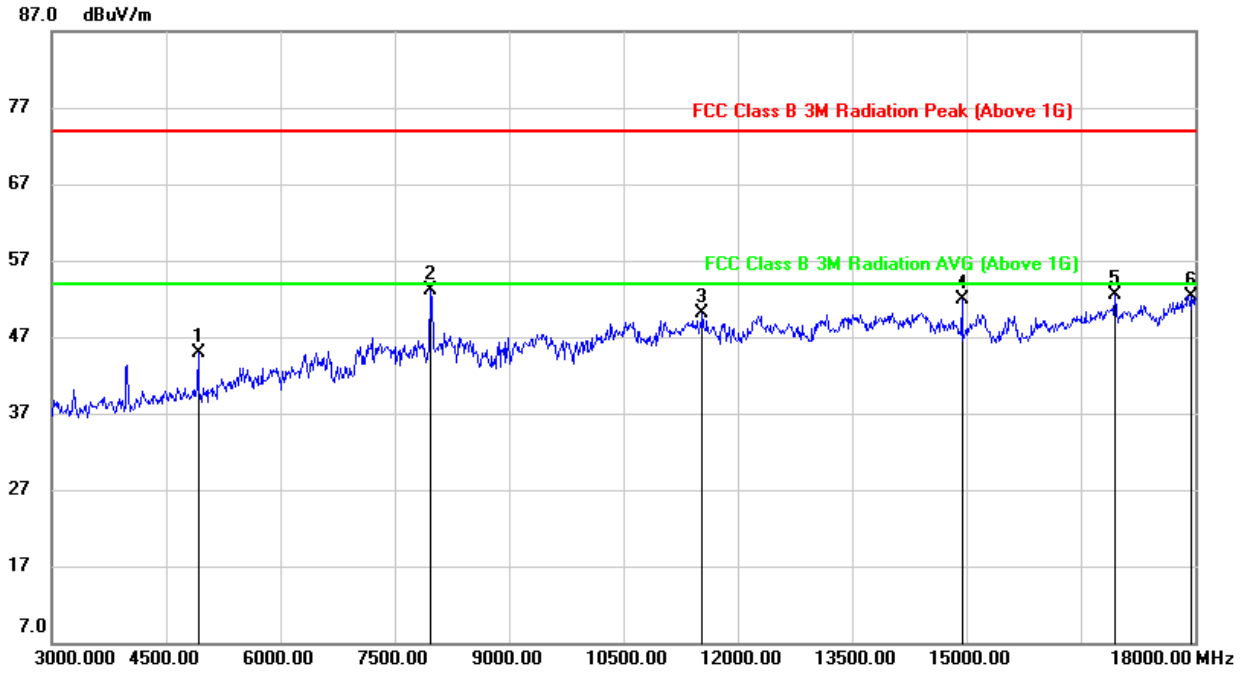

No.	Frequency (MHz)	Reading (dBuV)	Correct (dB/m)	Result (dBuV)	Limit (dBuV)	Margin (dB)	Remark
1	4920.000	44.84	0.02	44.86	74.00	-29.14	peak
2	7965.000	44.76	8.26	53.02	74.00	-20.98	peak
3	11535.000	36.00	14.10	50.10	74.00	-23.90	peak
4	14940.000	36.43	15.50	51.93	74.00	-22.07	peak
5	16950.000	32.35	20.13	52.48	74.00	-21.52	peak
6	17955.000	29.14	23.23	52.37	74.00	-21.63	peak

- Note: 1. Measurement = Reading Level + Correct Factor.
 2. If Peak Result complies with AV limit, AV Result is deemed to comply with AV limit.
 3. Peak: Peak detector.
 4. The High Pass filter loss factor already add into the correct factor.
 5. Proper operation of the transmitter prior to adding the filter to the measurement chain.



9.2.3. 802.11n HT20 MIMO MODE

2TX MODE (WORST-CASE CONFIGURATION)

HARMONICS AND SPURIOUS EMISSIONS (LOW CHANNEL, HORIZONTAL)

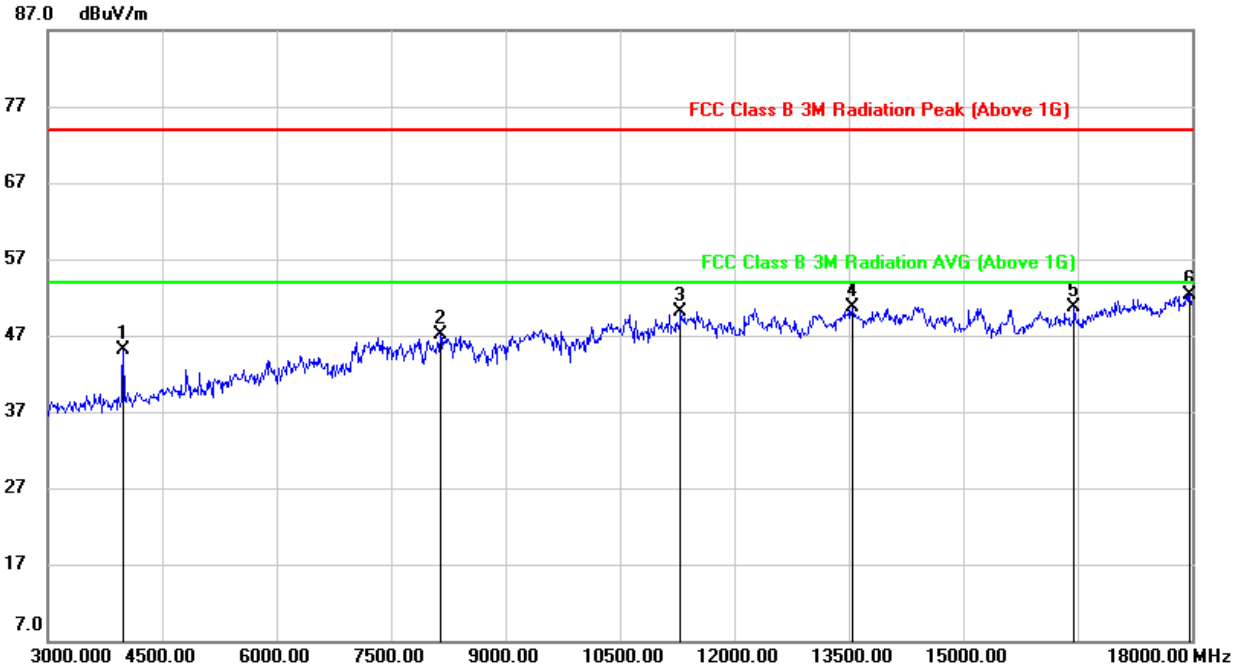

No.	Frequency (MHz)	Reading (dBuV)	Correct (dB/m)	Result (dBuV)	Limit (dBuV)	Margin (dB)	Remark
1	3990.000	48.04	-2.95	45.09	74.00	-28.91	peak
2	8145.000	37.74	9.30	47.04	74.00	-26.96	peak
3	11295.000	37.25	12.91	50.16	74.00	-23.84	peak
4	13545.000	34.84	15.85	50.69	74.00	-23.31	peak
5	16455.000	31.88	18.75	50.63	74.00	-23.37	peak
6	17970.000	29.15	23.24	52.39	74.00	-21.61	peak

- Note:
1. Measurement = Reading Level + Correct Factor.
 2. If Peak Result complies with AV limit, AV Result is deemed to comply with AV limit.
 3. Peak: Peak detector.
 4. The High Pass filter loss factor already add into the correct factor.
 5. Proper operation of the transmitter prior to adding the filter to the measurement chain.



HARMONICS AND SPURIOUS EMISSIONS (LOW CHANNEL, VERTICAL)

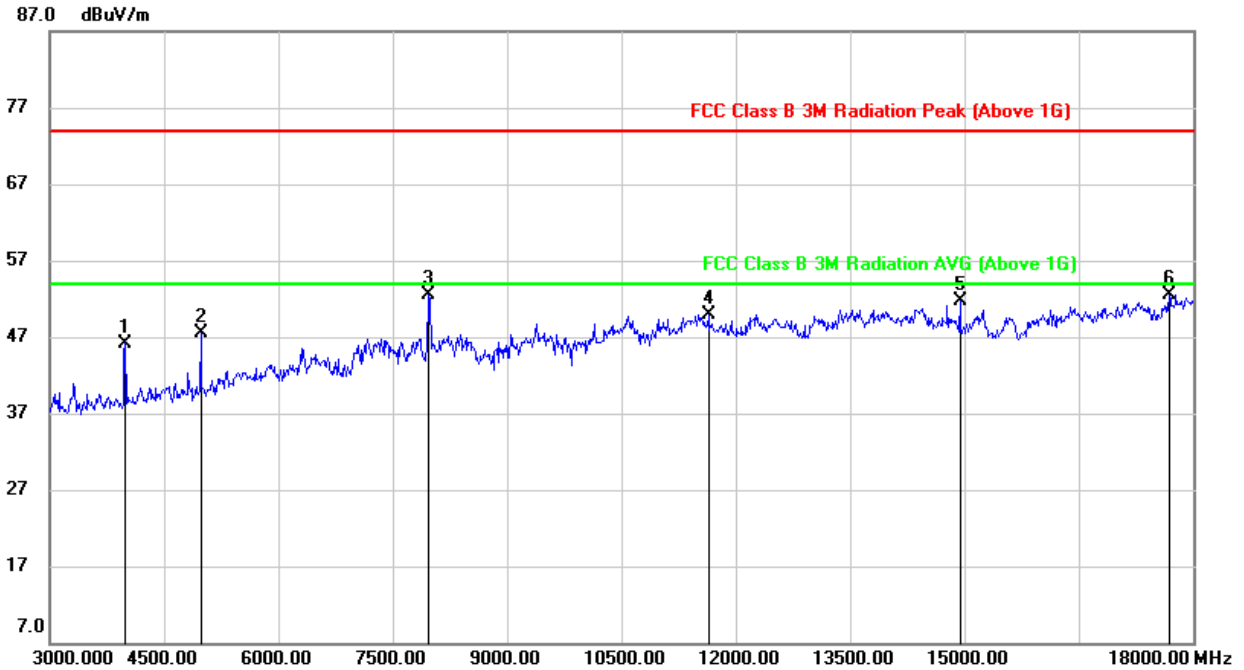

No.	Frequency (MHz)	Reading (dBuV)	Correct (dB/m)	Result (dBuV)	Limit (dBuV)	Margin (dB)	Remark
1	3990.000	49.15	-2.95	46.20	74.00	-27.80	peak
2	4980.000	47.19	0.37	47.56	74.00	-26.44	peak
3	7965.000	44.29	8.26	52.55	74.00	-21.45	peak
4	11640.000	35.89	13.96	49.85	74.00	-24.15	peak
5	14940.000	36.13	15.50	51.63	74.00	-22.37	peak
6	17685.000	30.41	22.11	52.52	74.00	-21.48	peak

- Note: 1. Measurement = Reading Level + Correct Factor.
 2. If Peak Result complies with AV limit, AV Result is deemed to comply with AV limit.
 3. Peak: Peak detector.
 4. The High Pass filter loss factor already add into the correct factor.
 5. Proper operation of the transmitter prior to adding the filter to the measurement chain.



HARMONICS AND SPURIOUS EMISSIONS (MID CHANNEL, HORIZONTAL)

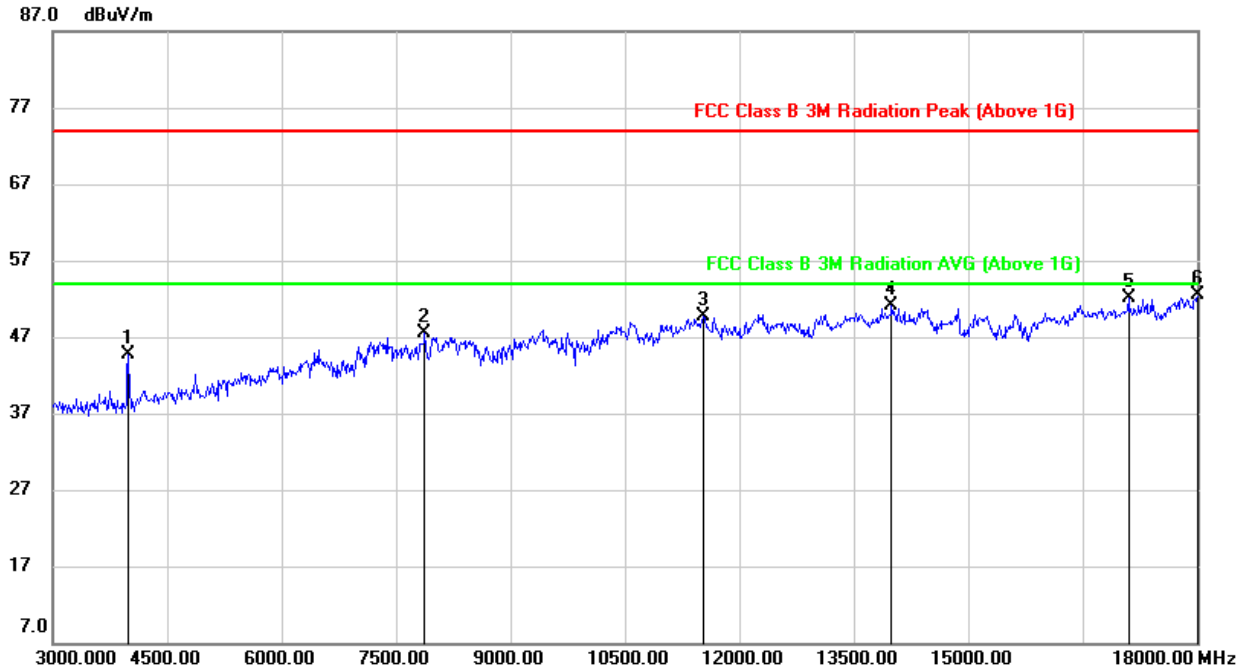

No.	Frequency (MHz)	Reading (dBuV)	Correct (dB/m)	Result (dBuV)	Limit (dBuV)	Margin (dB)	Remark
1	3990.000	47.64	-2.95	44.69	74.00	-29.31	peak
2	7875.000	38.91	8.55	47.46	74.00	-26.54	peak
3	11535.000	35.67	14.10	49.77	74.00	-24.23	peak
4	13995.000	34.80	16.35	51.15	74.00	-22.85	peak
5	17100.000	31.40	20.78	52.18	74.00	-21.82	peak
6	18000.000	29.25	23.27	52.52	74.00	-21.48	peak

- Note: 1. Measurement = Reading Level + Correct Factor.
 2. If Peak Result complies with AV limit, AV Result is deemed to comply with AV limit.
 3. Peak: Peak detector.
 4. The High Pass filter loss factor already add into the correct factor.
 5. Proper operation of the transmitter prior to adding the filter to the measurement chain.



HARMONICS AND SPURIOUS EMISSIONS (MID CHANNEL, VERTICAL)

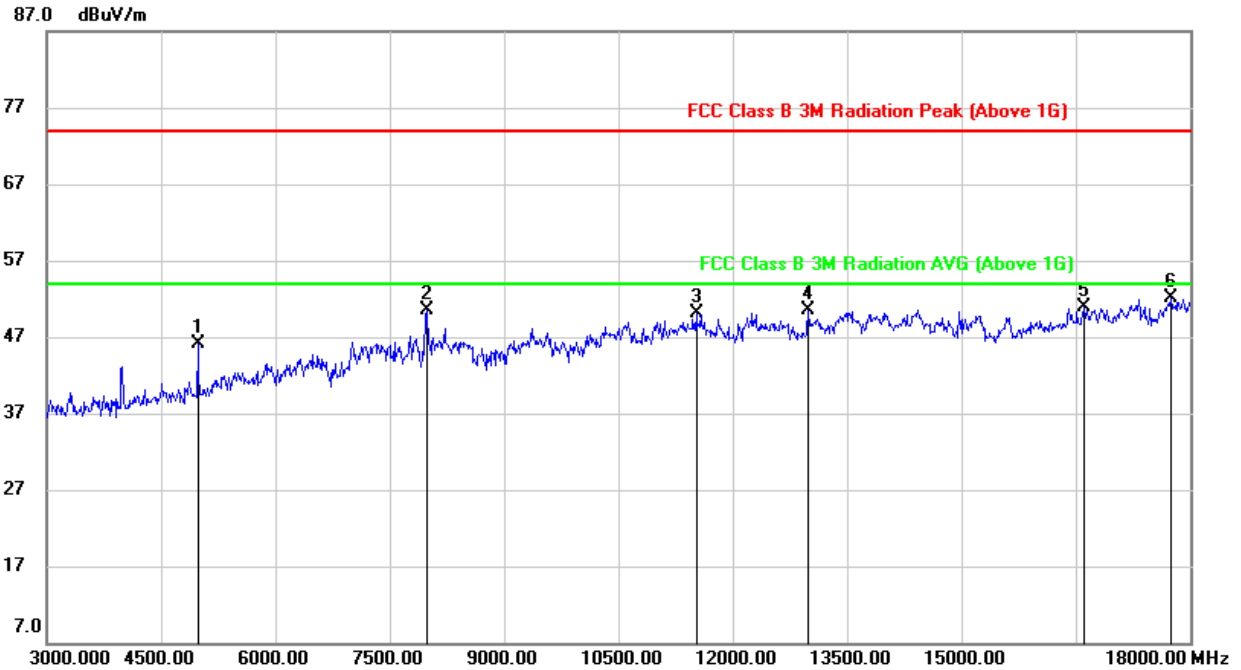

No.	Frequency (MHz)	Reading (dBuV)	Correct (dB/m)	Result (dBuV)	Limit (dBuV)	Margin (dB)	Remark
1	4980.000	45.80	0.37	46.17	74.00	-27.83	peak
2	7995.000	42.40	8.16	50.56	74.00	-23.44	peak
3	11520.000	36.03	14.10	50.13	74.00	-23.87	peak
4	12990.000	35.84	14.71	50.55	74.00	-23.45	peak
5	16605.000	31.46	19.40	50.86	74.00	-23.14	peak
6	17745.000	29.33	22.68	52.01	74.00	-21.99	peak

- Note: 1. Measurement = Reading Level + Correct Factor.
 2. If Peak Result complies with AV limit, AV Result is deemed to comply with AV limit.
 3. Peak: Peak detector.
 4. The High Pass filter loss factor already add into the correct factor.
 5. Proper operation of the transmitter prior to adding the filter to the measurement chain.



HARMONICS AND SPURIOUS EMISSIONS (HIGH CHANNEL, HORIZONTAL)

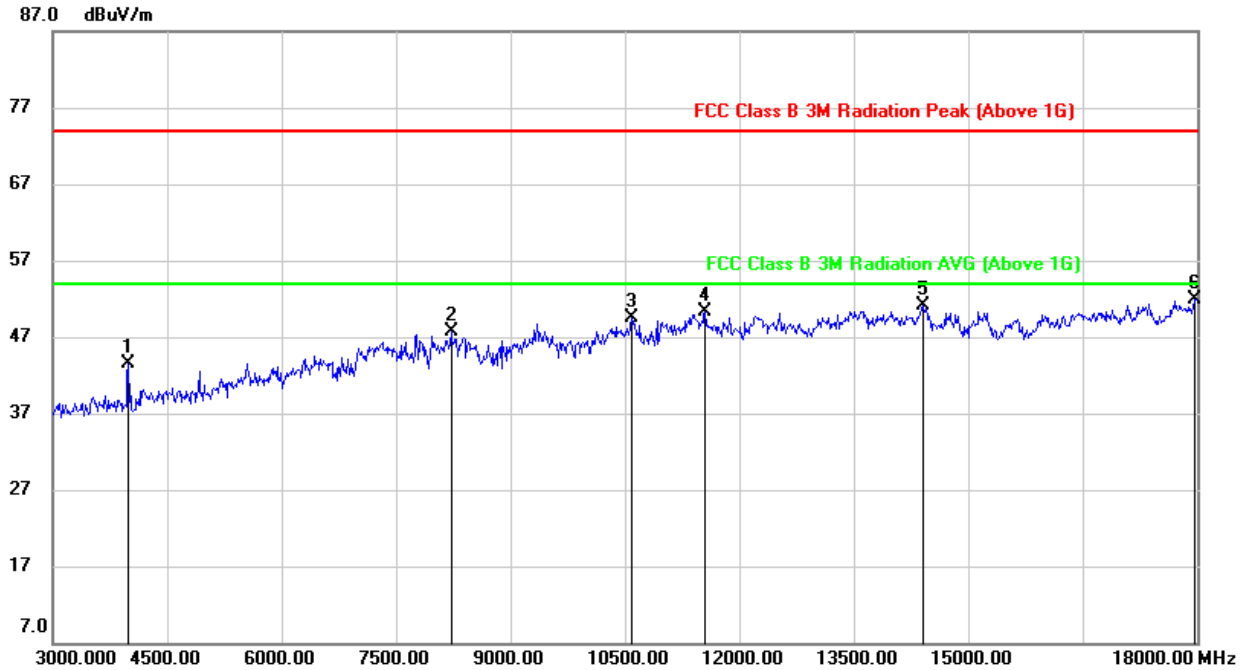

No.	Frequency (MHz)	Reading (dBuV)	Correct (dB/m)	Result (dBuV)	Limit (dBuV)	Margin (dB)	Remark
1	3990.000	46.40	-2.95	43.45	74.00	-30.55	peak
2	8220.000	38.23	9.40	47.63	74.00	-26.37	peak
3	10590.000	36.80	12.68	49.48	74.00	-24.52	peak
4	11550.000	36.08	14.13	50.21	74.00	-23.79	peak
5	14415.000	34.74	16.41	51.15	74.00	-22.85	peak
6	17970.000	28.67	23.24	51.91	74.00	-22.09	peak

- Note: 1. Measurement = Reading Level + Correct Factor.
 2. If Peak Result complies with AV limit, AV Result is deemed to comply with AV limit.
 3. Peak: Peak detector.
 4. The High Pass filter loss factor already add into the correct factor.
 5. Proper operation of the transmitter prior to adding the filter to the measurement chain.



HARMONICS AND SPURIOUS EMISSIONS (HIGH CHANNEL, VERTICAL)

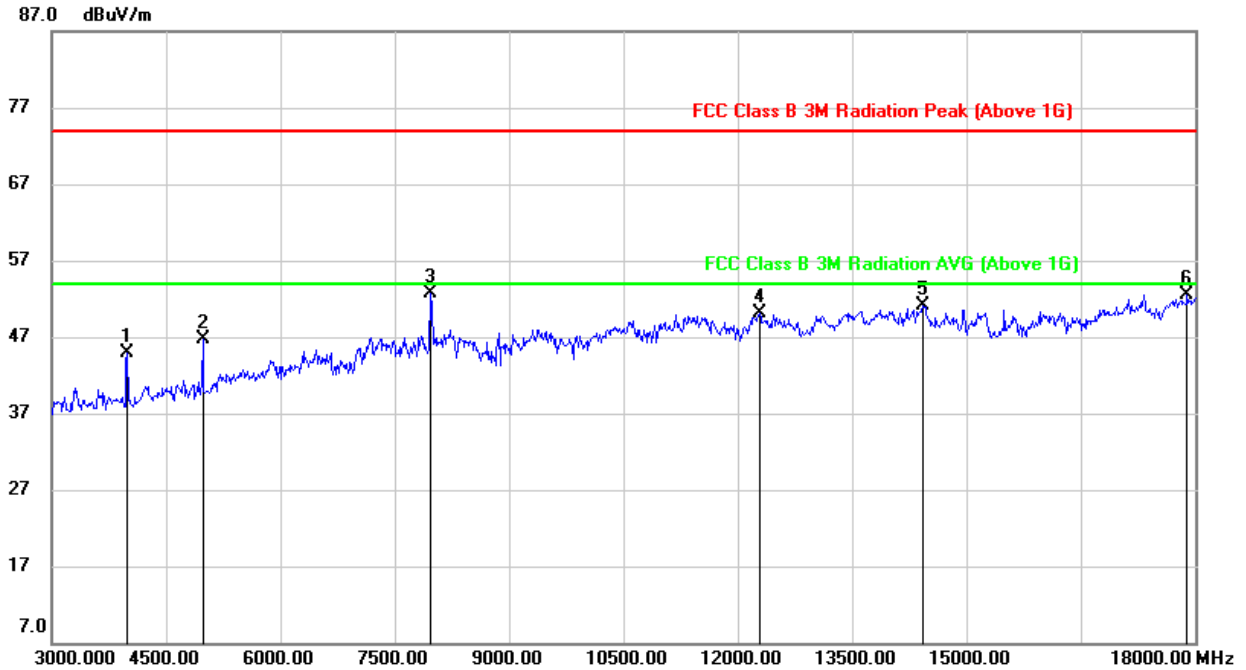

No.	Frequency (MHz)	Reading (dBuV)	Correct (dB/m)	Result (dBuV)	Limit (dBuV)	Margin (dB)	Remark
1	3990.000	47.86	-2.95	44.91	74.00	-29.09	peak
2	4980.000	46.37	0.37	46.74	74.00	-27.26	peak
3	7965.000	44.47	8.26	52.73	74.00	-21.27	peak
4	12285.000	35.80	14.37	50.17	74.00	-23.83	peak
5	14430.000	34.63	16.39	51.02	74.00	-22.98	peak
6	17895.000	29.33	23.16	52.49	74.00	-21.51	peak

- Note: 1. Measurement = Reading Level + Correct Factor.
 2. If Peak Result complies with AV limit, AV Result is deemed to comply with AV limit.
 3. Peak: Peak detector.
 4. The High Pass filter loss factor already add into the correct factor.
 5. Proper operation of the transmitter prior to adding the filter to the measurement chain.



9.2.4. 802.11n HT40 MIMO MODE

2TX MODE (WORST-CASE CONFIGURATION)

HARMONICS AND SPURIOUS EMISSIONS (LOW CHANNEL, HORIZONTAL)

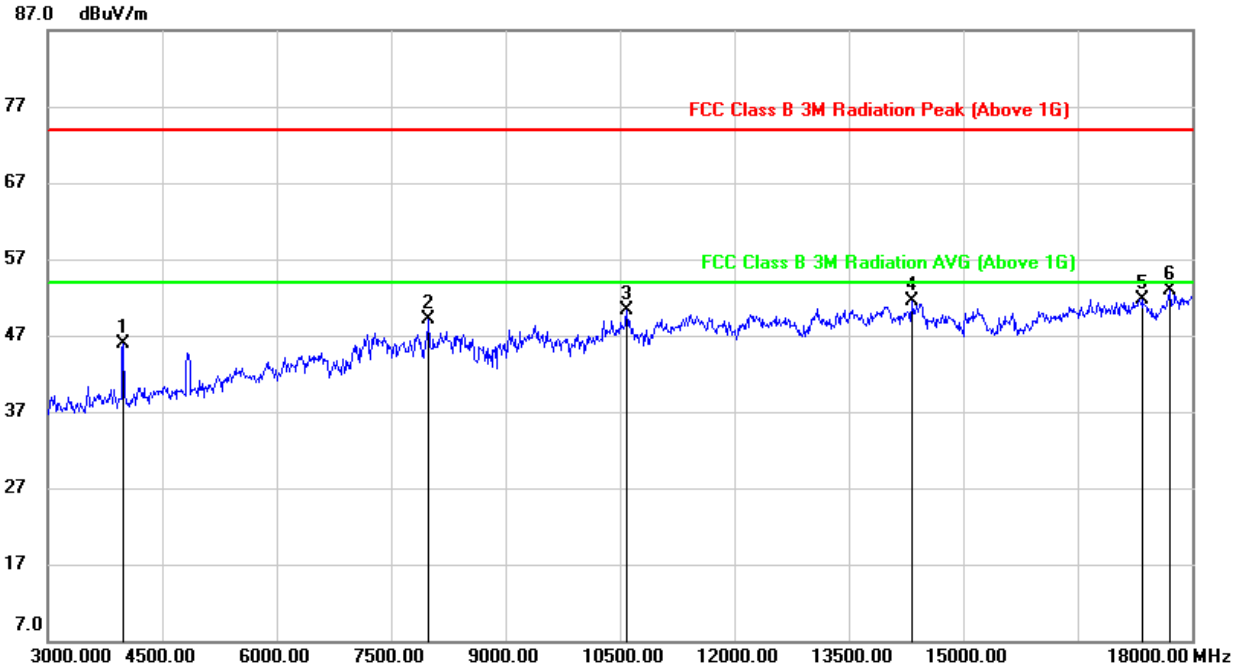

No.	Frequency (MHz)	Reading (dBuV)	Correct (dB/m)	Result (dBuV)	Limit (dBuV)	Margin (dB)	Remark
1	3990.000	48.87	-2.95	45.92	74.00	-28.08	peak
2	7995.000	40.85	8.16	49.01	74.00	-24.99	peak
3	10590.000	37.60	12.68	50.28	74.00	-23.72	peak
4	14325.000	35.15	16.33	51.48	74.00	-22.52	peak
5	17340.000	30.02	21.73	51.75	74.00	-22.25	peak
6	17715.000	30.45	22.39	52.84	74.00	-21.16	peak

- Note:
1. Measurement = Reading Level + Correct Factor.
 2. If Peak Result complies with AV limit, AV Result is deemed to comply with AV limit.
 3. Peak: Peak detector.
 4. The High Pass filter loss factor already add into the correct factor.
 5. Proper operation of the transmitter prior to adding the filter to the measurement chain.



HARMONICS AND SPURIOUS EMISSIONS (LOW CHANNEL, VERTICAL)

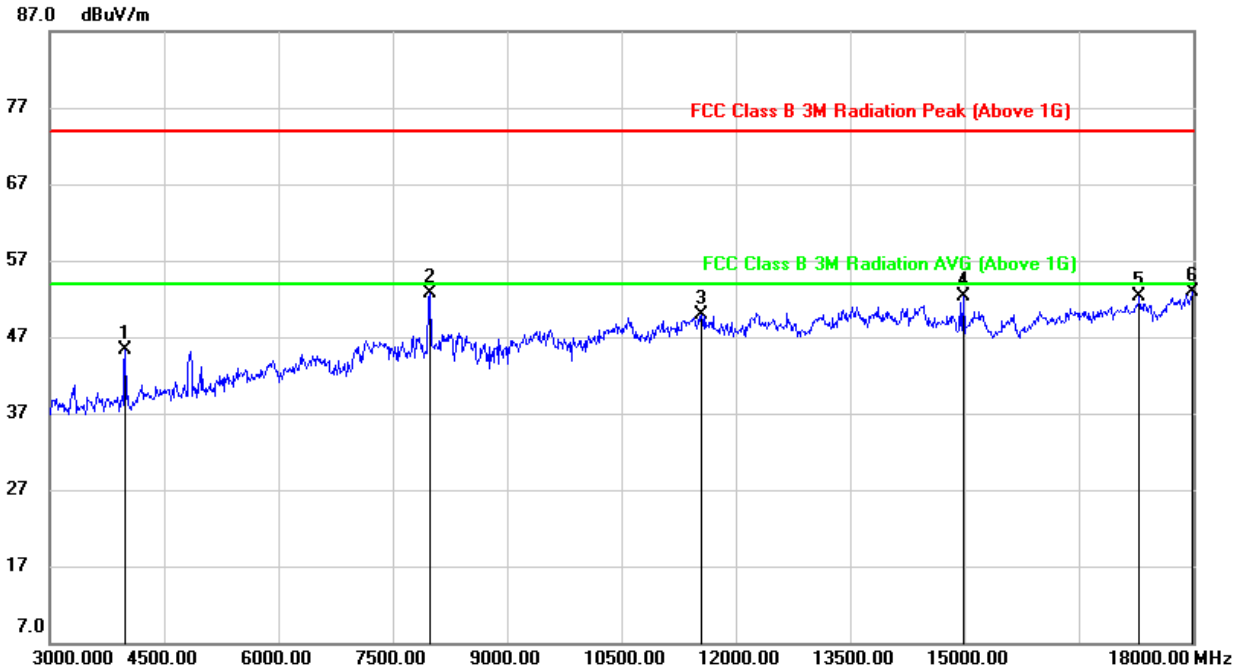

No.	Frequency (MHz)	Reading (dBuV)	Correct (dB/m)	Result (dBuV)	Limit (dBuV)	Margin (dB)	Remark
1	3990.000	48.25	-2.95	45.30	74.00	-28.70	peak
2	7995.000	44.60	8.16	52.76	74.00	-21.24	peak
3	11550.000	35.78	14.13	49.91	74.00	-24.09	peak
4	14985.000	36.93	15.47	52.40	74.00	-21.60	peak
5	17295.000	30.48	21.86	52.34	74.00	-21.66	peak
6	17985.000	29.73	23.25	52.98	74.00	-21.02	peak

- Note: 1. Measurement = Reading Level + Correct Factor.
 2. If Peak Result complies with AV limit, AV Result is deemed to comply with AV limit.
 3. Peak: Peak detector.
 4. The High Pass filter loss factor already add into the correct factor.
 5. Proper operation of the transmitter prior to adding the filter to the measurement chain.



HARMONICS AND SPURIOUS EMISSIONS (MID CHANNEL, HORIZONTAL)

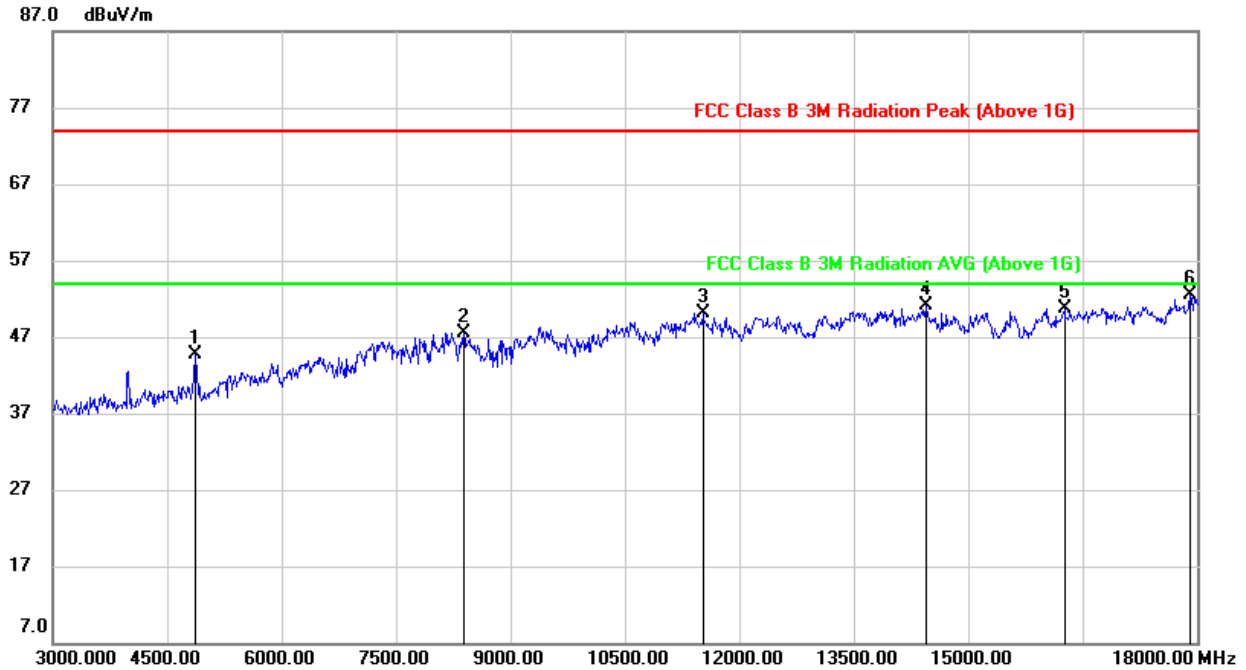

No.	Frequency (MHz)	Reading (dBuV)	Correct (dB/m)	Result (dBuV)	Limit (dBuV)	Margin (dB)	Remark
1	4860.000	44.76	-0.15	44.61	74.00	-29.39	peak
2	8385.000	38.81	8.68	47.49	74.00	-26.51	peak
3	11520.000	36.06	14.10	50.16	74.00	-23.84	peak
4	14445.000	34.76	16.37	51.13	74.00	-22.87	peak
5	16260.000	32.67	18.01	50.68	74.00	-23.32	peak
6	17910.000	29.34	23.17	52.51	74.00	-21.49	peak

- Note: 1. Measurement = Reading Level + Correct Factor.
 2. If Peak Result complies with AV limit, AV Result is deemed to comply with AV limit.
 3. Peak: Peak detector.
 4. The High Pass filter loss factor already add into the correct factor.
 5. Proper operation of the transmitter prior to adding the filter to the measurement chain.



HARMONICS AND SPURIOUS EMISSIONS (MID CHANNEL, VERTICAL)

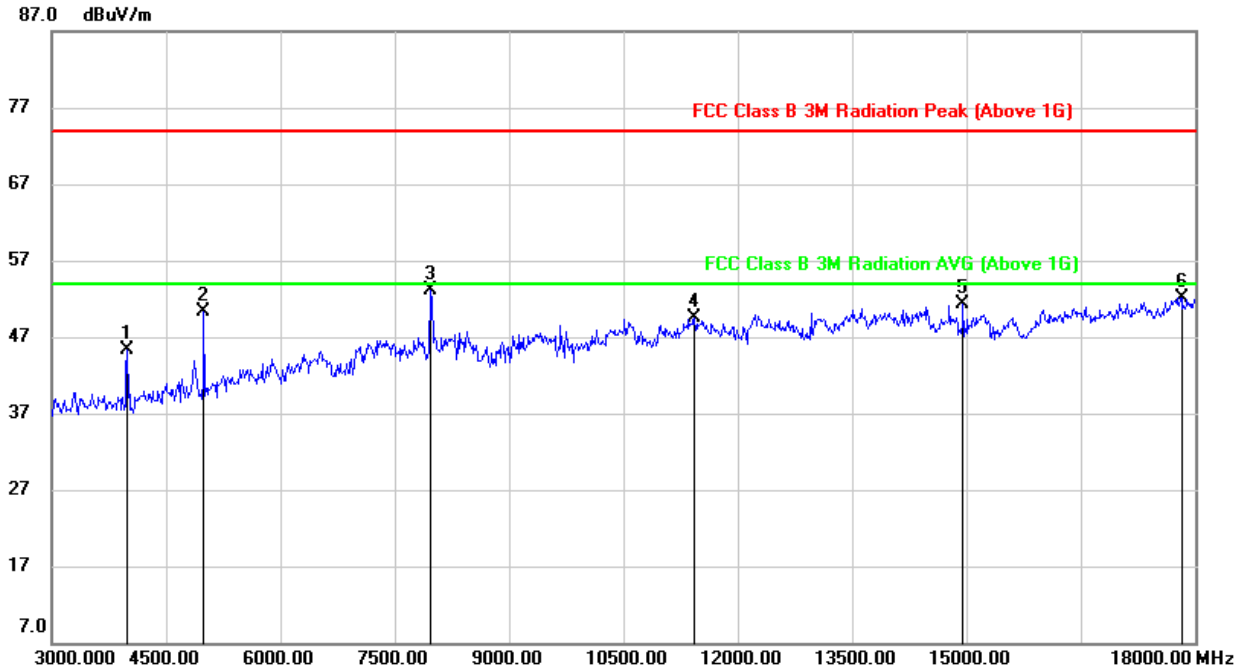

No.	Frequency (MHz)	Reading (dBuV)	Correct (dB/m)	Result (dBuV)	Limit (dBuV)	Margin (dB)	Remark
1	3990.000	48.17	-2.95	45.22	74.00	-28.78	peak
2	4995.000	49.85	0.46	50.31	74.00	-23.69	peak
3	7965.000	44.75	8.26	53.01	74.00	-20.99	peak
4	11430.000	36.03	13.57	49.60	74.00	-24.40	peak
5	14955.000	35.78	15.49	51.27	74.00	-22.73	peak
6	17820.000	28.92	23.21	52.13	74.00	-21.87	peak

- Note: 1. Measurement = Reading Level + Correct Factor.
 2. If Peak Result complies with AV limit, AV Result is deemed to comply with AV limit.
 3. Peak: Peak detector.
 4. The High Pass filter loss factor already add into the correct factor.
 5. Proper operation of the transmitter prior to adding the filter to the measurement chain.



HARMONICS AND SPURIOUS EMISSIONS (HIGH CHANNEL, HORIZONTAL)

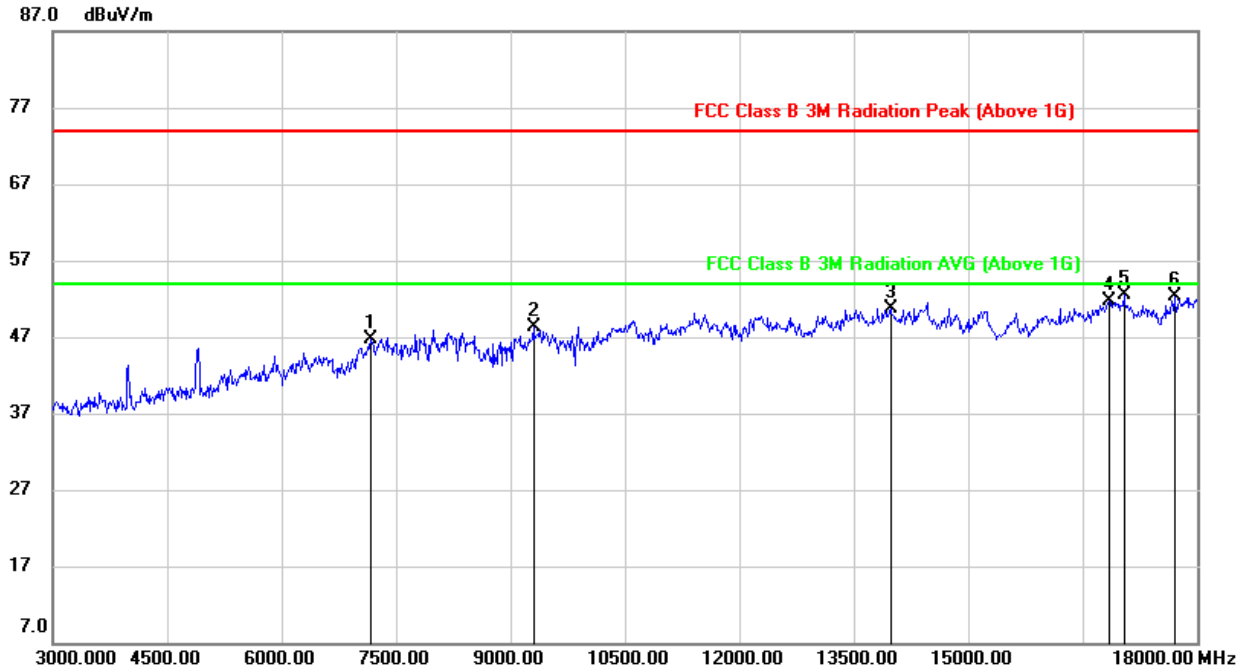

No.	Frequency (MHz)	Reading (dBuV)	Correct (dB/m)	Result (dBuV)	Limit (dBuV)	Margin (dB)	Remark
1	7170.000	39.76	6.87	46.63	74.00	-27.37	peak
2	9300.000	38.63	9.66	48.29	74.00	-25.71	peak
3	13980.000	34.48	16.32	50.80	74.00	-23.20	peak
4	16845.000	31.78	19.92	51.70	74.00	-22.30	peak
5	17040.000	31.94	20.51	52.45	74.00	-21.55	peak
6	17700.000	30.15	22.24	52.39	74.00	-21.61	peak

- Note: 1. Measurement = Reading Level + Correct Factor.
 2. If Peak Result complies with AV limit, AV Result is deemed to comply with AV limit.
 3. Peak: Peak detector.
 4. The High Pass filter loss factor already add into the correct factor.
 5. Proper operation of the transmitter prior to adding the filter to the measurement chain.



HARMONICS AND SPURIOUS EMISSIONS (HIGH CHANNEL, VERTICAL)

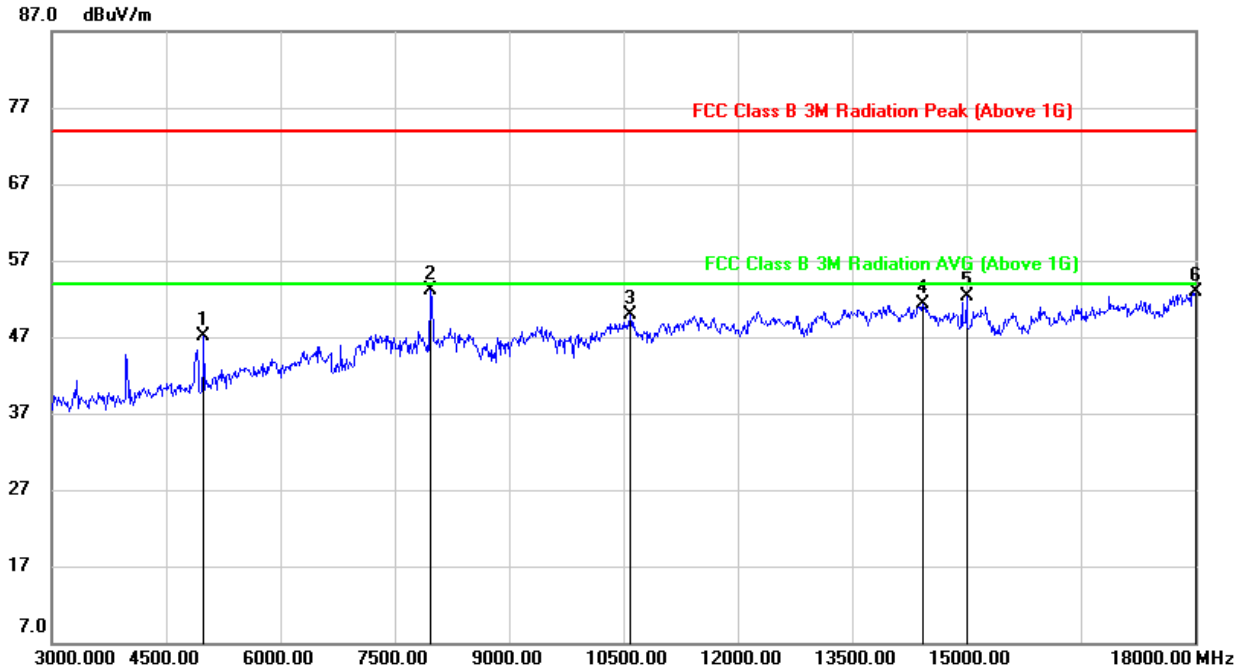

No.	Frequency (MHz)	Reading (dBuV)	Correct (dB/m)	Result (dBuV)	Limit (dBuV)	Margin (dB)	Remark
1	4995.000	46.55	0.46	47.01	74.00	-26.99	peak
2	7965.000	44.85	8.26	53.11	74.00	-20.89	peak
3	10590.000	37.22	12.68	49.90	74.00	-24.10	peak
4	14430.000	34.89	16.39	51.28	74.00	-22.72	peak
5	15000.000	36.84	15.47	52.31	74.00	-21.69	peak
6	18000.000	29.56	23.27	52.83	74.00	-21.17	peak

- Note: 1. Measurement = Reading Level + Correct Factor.
 2. If Peak Result complies with AV limit, AV Result is deemed to comply with AV limit.
 3. Peak: Peak detector.
 4. The High Pass filter loss factor already add into the correct factor.
 5. Proper operation of the transmitter prior to adding the filter to the measurement chain.



9.3. SPURIOUS EMISSIONS (1~3GHz)

9.3.1. 802.11b SISO MODE

1TX MODE FOR ANT1 (WORST-CASE CONFIGURATION)

HARMONICS AND SPURIOUS EMISSIONS (LOW CHANNEL, HORIZONTAL)

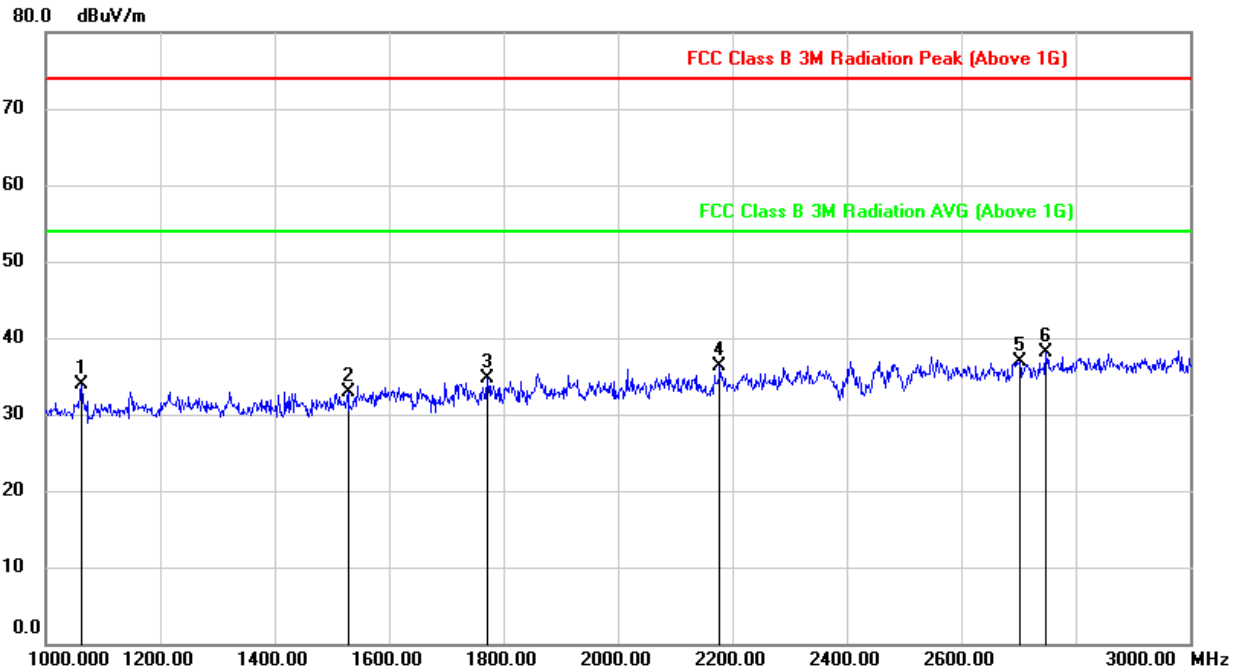

No.	Frequency (MHz)	Reading (dBuV)	Correct (dB/m)	Result (dBuV)	Limit (dBuV)	Margin (dB)	Remark
1	1062.000	47.04	-13.23	33.81	74.00	-40.19	peak
2	1528.000	44.46	-11.49	32.97	74.00	-41.03	peak
3	1772.000	44.65	-9.90	34.75	74.00	-39.25	peak
4	2178.000	44.57	-8.20	36.37	74.00	-37.63	peak
5	2702.000	42.90	-5.96	36.94	74.00	-37.06	peak
6	2748.000	43.76	-5.65	38.11	74.00	-35.89	peak

- Note: 1. Peak Result = Reading Level + Correct Factor.
 2. If Peak Result complies with AV limit, AV Result is deemed to comply with AV limit.
 3. Peak: Peak detector.
 4. The Band Reject filter loss factor already add into the correct factor.
 5. Proper operation of the transmitter prior to adding the filter to the measurement chain.



HARMONICS AND SPURIOUS EMISSIONS (LOW CHANNEL, VERTICAL)

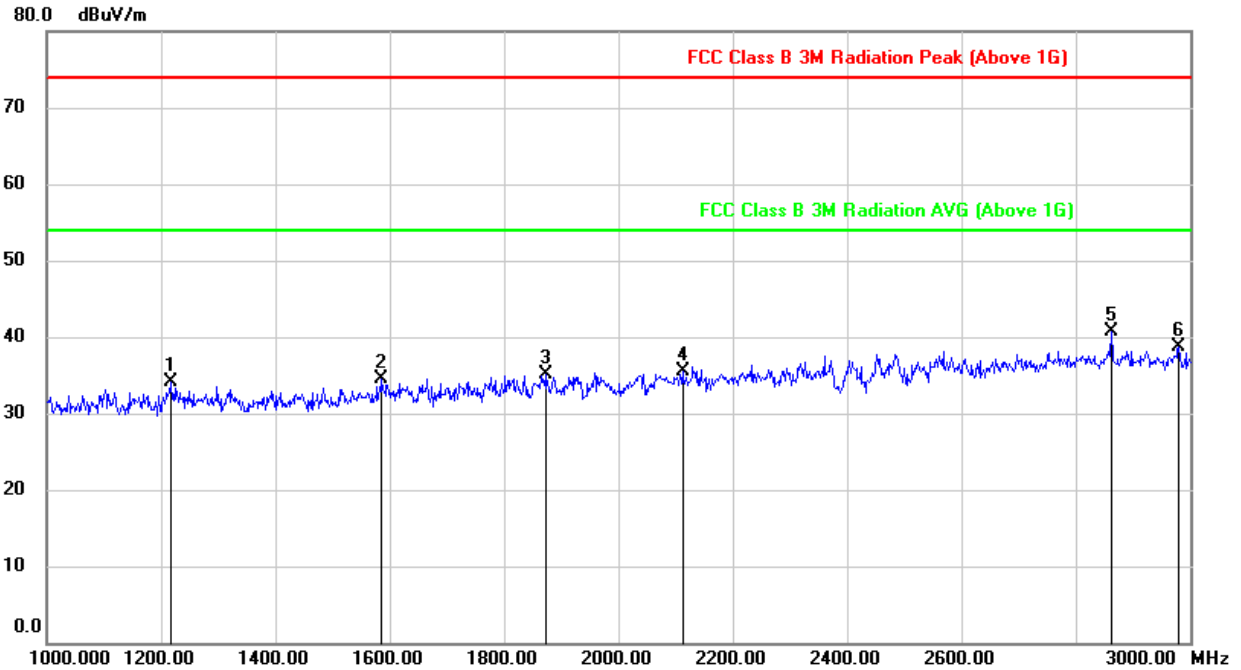

No.	Frequency (MHz)	Reading (dBuV)	Correct (dB/m)	Result (dBuV)	Limit (dBuV)	Margin (dB)	Remark
1	1216.000	46.22	-12.14	34.08	74.00	-39.92	peak
2	1586.000	45.44	-10.96	34.48	74.00	-39.52	peak
3	1872.000	44.47	-9.43	35.04	74.00	-38.96	peak
4	2112.000	44.07	-8.53	35.54	74.00	-38.46	peak
5	2862.000	45.63	-4.95	40.68	74.00	-33.32	peak
6	2980.000	43.13	-4.40	38.73	74.00	-35.27	peak

- Note: 1. Peak Result = Reading Level + Correct Factor.
 2. If Peak Result complies with AV limit, AV Result is deemed to comply with AV limit.
 3. Peak: Peak detector.
 4. The Band Reject filter loss factor already add into the correct factor.
 5. Proper operation of the transmitter prior to adding the filter to the measurement chain.



HARMONICS AND SPURIOUS EMISSIONS (MID CHANNEL, HORIZONTAL)

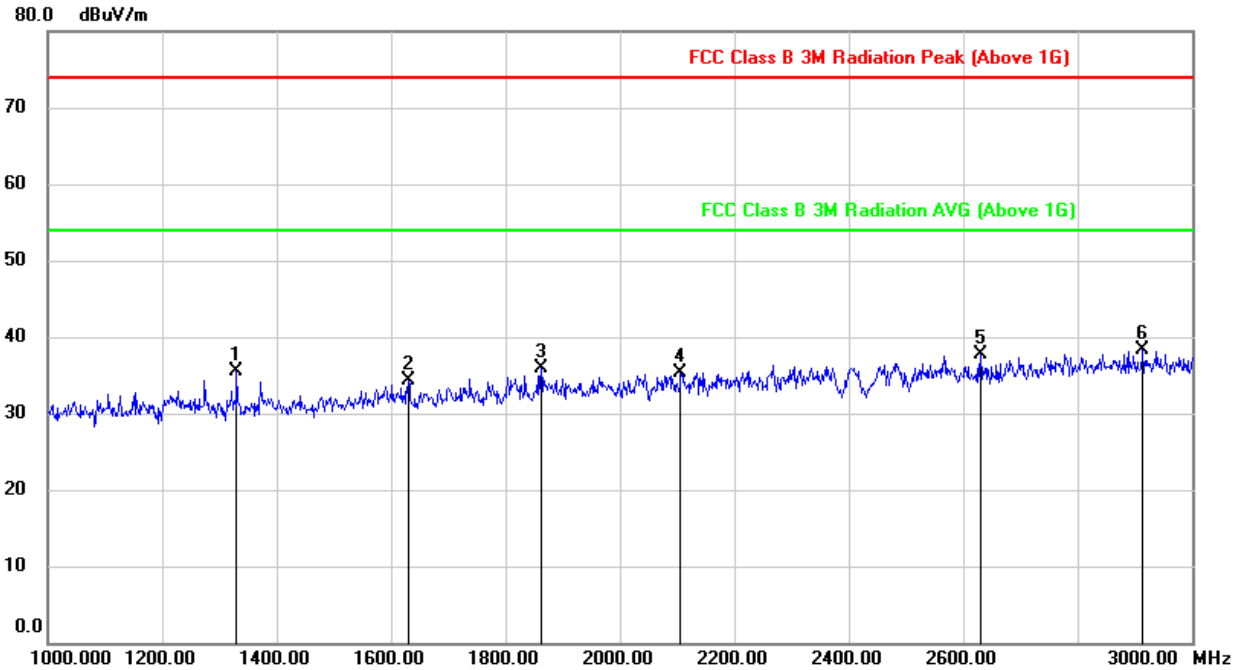

No.	Frequency (MHz)	Reading (dBuV)	Correct (dB/m)	Result (dBuV)	Limit (dBuV)	Margin (dB)	Remark
1	1330.000	47.29	-11.87	35.42	74.00	-38.58	peak
2	1630.000	45.08	-10.76	34.32	74.00	-39.68	peak
3	1862.000	45.33	-9.45	35.88	74.00	-38.12	peak
4	2106.000	43.86	-8.56	35.30	74.00	-38.70	peak
5	2630.000	44.08	-6.40	37.68	74.00	-36.32	peak
6	2914.000	42.94	-4.68	38.26	74.00	-35.74	peak

- Note: 1. Peak Result = Reading Level + Correct Factor.
 2. If Peak Result complies with AV limit, AV Result is deemed to comply with AV limit.
 3. Peak: Peak detector.
 4. The Band Reject filter loss factor already add into the correct factor.
 5. Proper operation of the transmitter prior to adding the filter to the measurement chain.



HARMONICS AND SPURIOUS EMISSIONS (MID CHANNEL, VERTICAL)

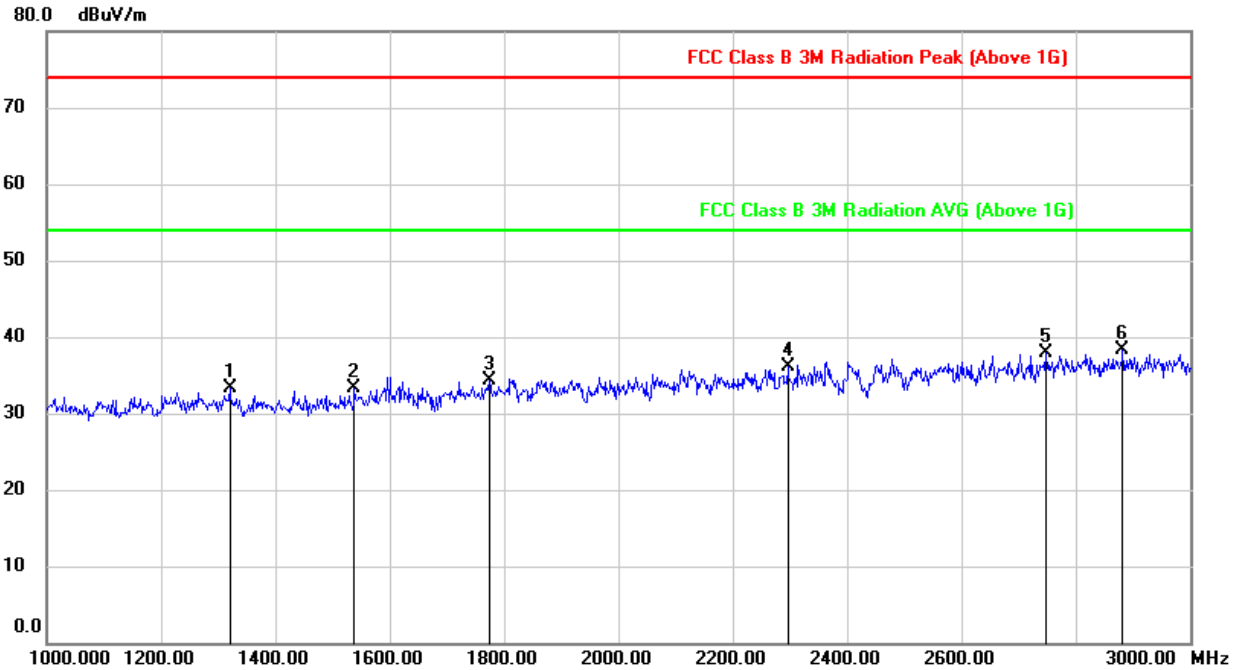

No.	Frequency (MHz)	Reading (dBuV)	Correct (dB/m)	Result (dBuV)	Limit (dBuV)	Margin (dB)	Remark
1	1320.000	45.26	-11.86	33.40	74.00	-40.60	peak
2	1538.000	44.71	-11.41	33.30	74.00	-40.70	peak
3	1774.000	44.17	-9.88	34.29	74.00	-39.71	peak
4	2296.000	43.64	-7.49	36.15	74.00	-37.85	peak
5	2748.000	43.46	-5.65	37.81	74.00	-36.19	peak
6	2882.000	43.15	-4.84	38.31	74.00	-35.69	peak

- Note: 1. Peak Result = Reading Level + Correct Factor.
 2. If Peak Result complies with AV limit, AV Result is deemed to comply with AV limit.
 3. Peak: Peak detector.
 4. The Band Reject filter loss factor already add into the correct factor.
 5. Proper operation of the transmitter prior to adding the filter to the measurement chain.



HARMONICS AND SPURIOUS EMISSIONS (HIGH CHANNEL, HORIZONTAL)

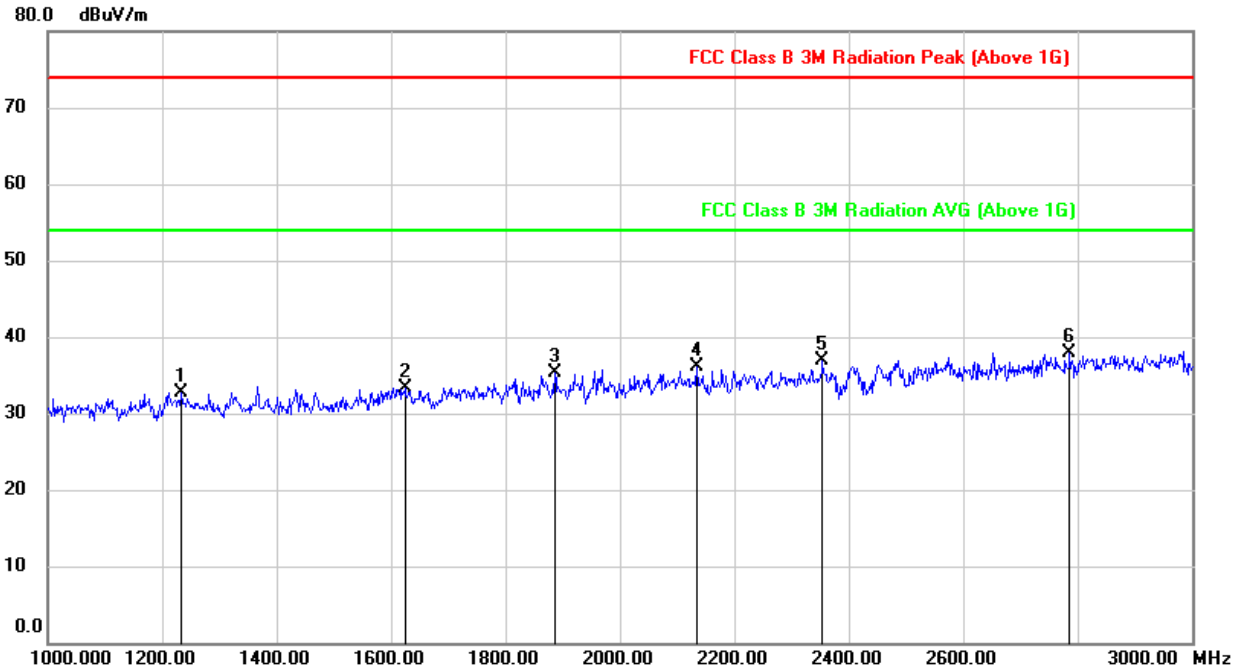

No.	Frequency (MHz)	Reading (dBuV)	Correct (dB/m)	Result (dBuV)	Limit (dBuV)	Margin (dB)	Remark
1	1234.000	44.88	-12.08	32.80	74.00	-41.20	peak
2	1624.000	44.14	-10.77	33.37	74.00	-40.63	peak
3	1886.000	44.73	-9.39	35.34	74.00	-38.66	peak
4	2134.000	44.61	-8.42	36.19	74.00	-37.81	peak
5	2354.000	44.16	-7.22	36.94	74.00	-37.06	peak
6	2786.000	43.24	-5.39	37.85	74.00	-36.15	peak

- Note: 1. Peak Result = Reading Level + Correct Factor.
 2. If Peak Result complies with AV limit, AV Result is deemed to comply with AV limit.
 3. Peak: Peak detector.
 4. The Band Reject filter loss factor already add into the correct factor.
 5. Proper operation of the transmitter prior to adding the filter to the measurement chain.



HARMONICS AND SPURIOUS EMISSIONS (HIGH CHANNEL, VERTICAL)

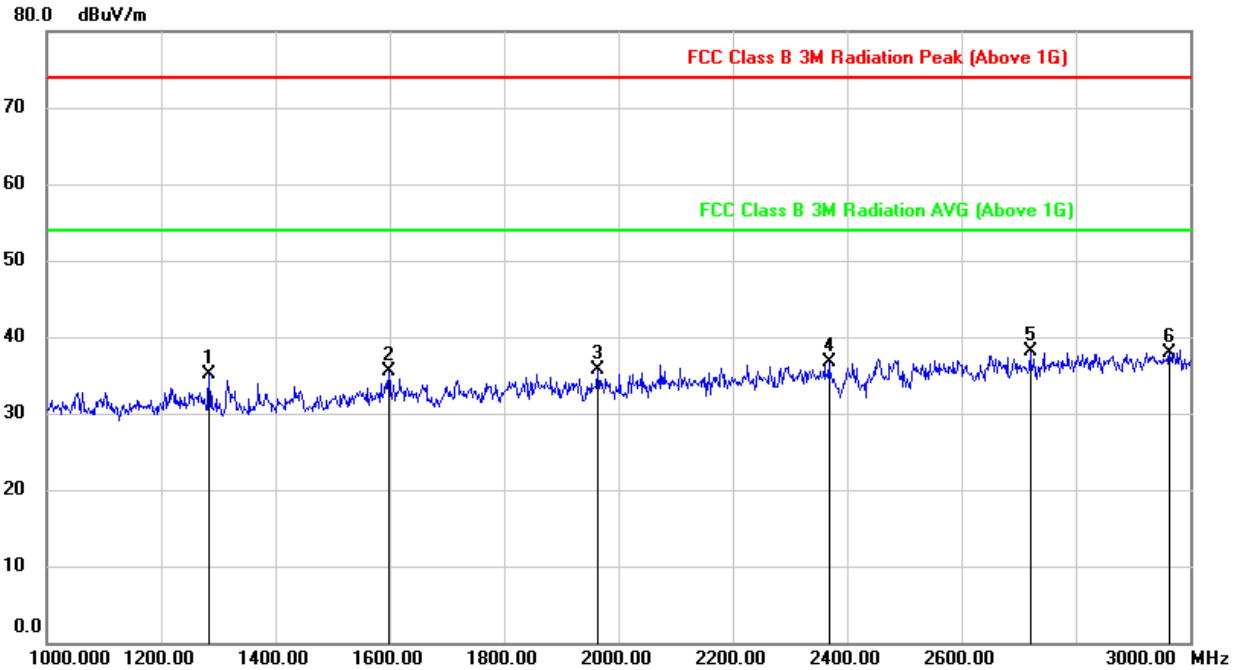

No.	Frequency (MHz)	Reading (dBuV)	Correct (dB/m)	Result (dBuV)	Limit (dBuV)	Margin (dB)	Remark
1	1284.000	46.93	-11.91	35.02	74.00	-38.98	peak
2	1598.000	46.37	-10.85	35.52	74.00	-38.48	peak
3	1964.000	45.16	-9.41	35.75	74.00	-38.25	peak
4	2368.000	43.88	-7.16	36.72	74.00	-37.28	peak
5	2720.000	43.86	-5.84	38.02	74.00	-35.98	peak
6	2964.000	42.48	-4.48	38.00	74.00	-36.00	peak

- Note: 1. Peak Result = Reading Level + Correct Factor.
 2. If Peak Result complies with AV limit, AV Result is deemed to comply with AV limit.
 3. Peak: Peak detector.
 4. The Band Reject filter loss factor already add into the correct factor.
 5. Proper operation of the transmitter prior to adding the filter to the measurement chain.



9.3.2. 802.11g SISO MODE

1TX MODE FOR ANT1 (WORST-CASE CONFIGURATION)

HARMONICS AND SPURIOUS EMISSIONS (LOW CHANNEL, HORIZONTAL)

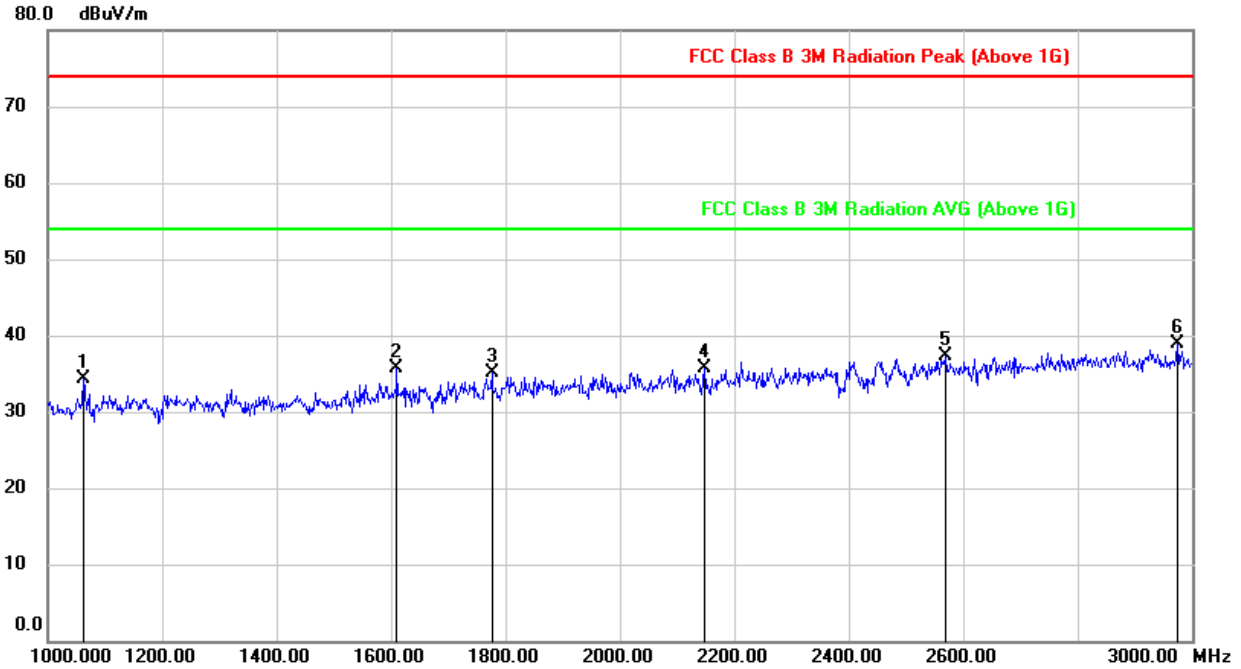

No.	Frequency (MHz)	Reading (dBuV)	Correct (dB/m)	Result (dBuV)	Limit (dBuV)	Margin (dB)	Remark
1	1062.000	47.52	-13.23	34.29	74.00	-39.71	peak
2	1610.000	46.59	-10.80	35.79	74.00	-38.21	peak
3	1776.000	44.88	-9.86	35.02	74.00	-38.98	peak
4	2148.000	44.00	-8.34	35.66	74.00	-38.34	peak
5	2568.000	43.68	-6.46	37.22	74.00	-36.78	peak
6	2974.000	43.29	-4.43	38.86	74.00	-35.14	peak

- Note:
1. Peak Result = Reading Level + Correct Factor.
 2. If Peak Result complies with AV limit, AV Result is deemed to comply with AV limit.
 3. Peak: Peak detector.
 4. The Band Reject filter loss factor already add into the correct factor.
 5. Proper operation of the transmitter prior to adding the filter to the measurement chain.



HARMONICS AND SPURIOUS EMISSIONS (LOW CHANNEL, VERTICAL)

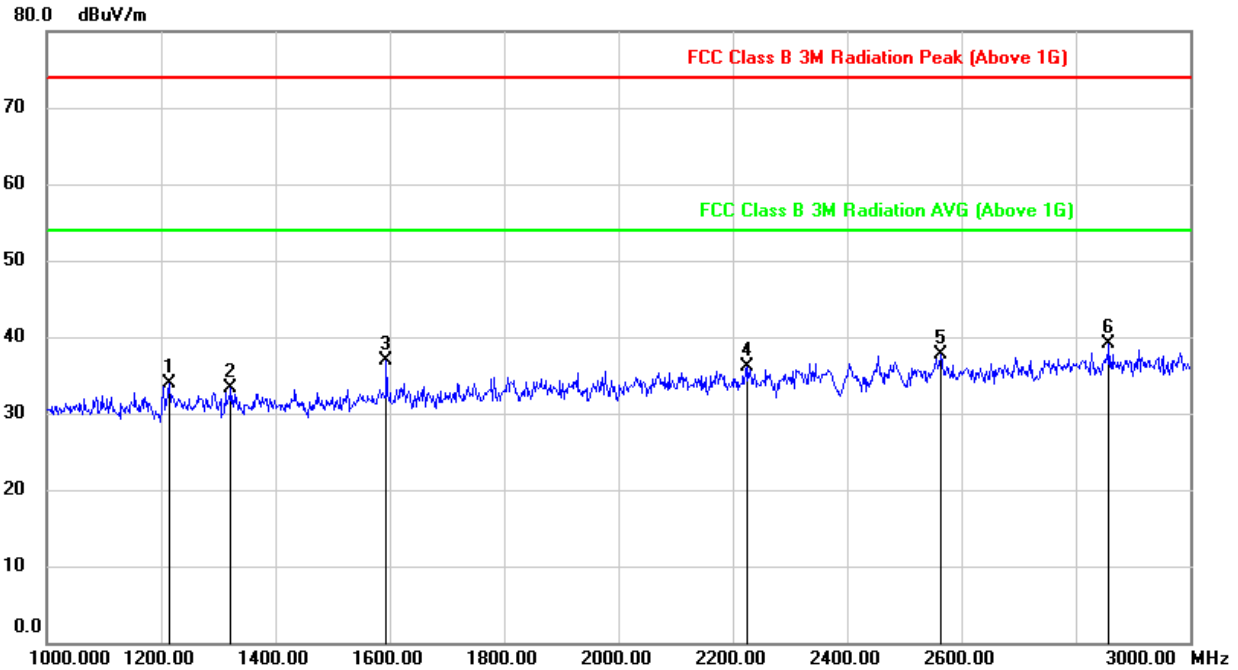

No.	Frequency (MHz)	Reading (dBuV)	Correct (dB/m)	Result (dBuV)	Limit (dBuV)	Margin (dB)	Remark
1	1214.000	46.09	-12.14	33.95	74.00	-40.05	peak
2	1322.000	45.16	-11.86	33.30	74.00	-40.70	peak
3	1594.000	47.73	-10.88	36.85	74.00	-37.15	peak
4	2224.000	44.05	-7.95	36.10	74.00	-37.90	peak
5	2564.000	44.20	-6.43	37.77	74.00	-36.23	peak
6	2858.000	44.00	-4.97	39.03	74.00	-34.97	peak

- Note: 1. Peak Result = Reading Level + Correct Factor.
 2. If Peak Result complies with AV limit, AV Result is deemed to comply with AV limit.
 3. Peak: Peak detector.
 4. The Band Reject filter loss factor already add into the correct factor.
 5. Proper operation of the transmitter prior to adding the filter to the measurement chain.



HARMONICS AND SPURIOUS EMISSIONS (MID CHANNEL, HORIZONTAL)

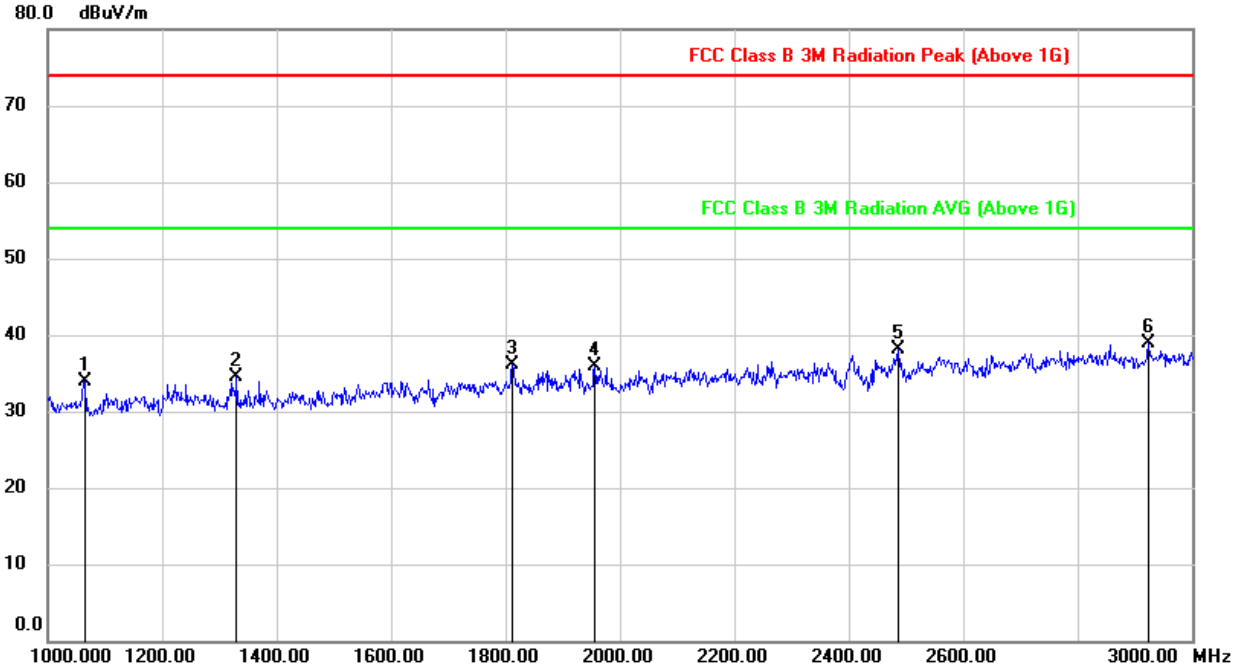

No.	Frequency (MHz)	Reading (dBuV)	Correct (dB/m)	Result (dBuV)	Limit (dBuV)	Margin (dB)	Remark
1	1064.000	47.17	-13.21	33.96	74.00	-40.04	peak
2	1330.000	46.33	-11.87	34.46	74.00	-39.54	peak
3	1812.000	45.61	-9.58	36.03	74.00	-37.97	peak
4	1956.000	45.29	-9.40	35.89	74.00	-38.11	peak
5	2486.000	44.45	-6.29	38.16	74.00	-35.84	peak
6	2924.000	43.45	-4.64	38.81	74.00	-35.19	peak

- Note: 1. Peak Result = Reading Level + Correct Factor.
 2. If Peak Result complies with AV limit, AV Result is deemed to comply with AV limit.
 3. Peak: Peak detector.
 4. The Band Reject filter loss factor already add into the correct factor.
 5. Proper operation of the transmitter prior to adding the filter to the measurement chain.



HARMONICS AND SPURIOUS EMISSIONS (MID CHANNEL, VERTICAL)

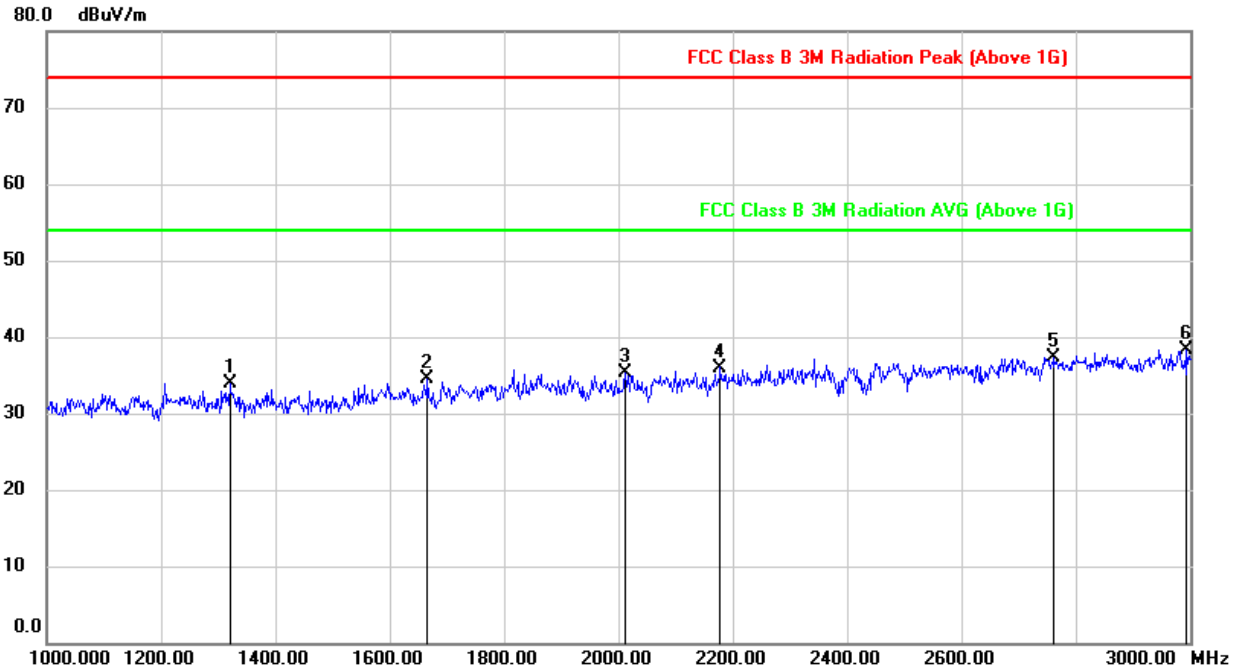

No.	Frequency (MHz)	Reading (dBuV)	Correct (dB/m)	Result (dBuV)	Limit (dBuV)	Margin (dB)	Remark
1	1320.000	45.85	-11.86	33.99	74.00	-40.01	peak
2	1666.000	45.10	-10.68	34.42	74.00	-39.58	peak
3	2012.000	44.66	-9.33	35.33	74.00	-38.67	peak
4	2178.000	44.20	-8.20	36.00	74.00	-38.00	peak
5	2762.000	42.92	-5.55	37.37	74.00	-36.63	peak
6	2994.000	42.64	-4.34	38.30	74.00	-35.70	peak

- Note: 1. Peak Result = Reading Level + Correct Factor.
 2. If Peak Result complies with AV limit, AV Result is deemed to comply with AV limit.
 3. Peak: Peak detector.
 4. The Band Reject filter loss factor already add into the correct factor.
 5. Proper operation of the transmitter prior to adding the filter to the measurement chain.



HARMONICS AND SPURIOUS EMISSIONS (HIGH CHANNEL, HORIZONTAL)

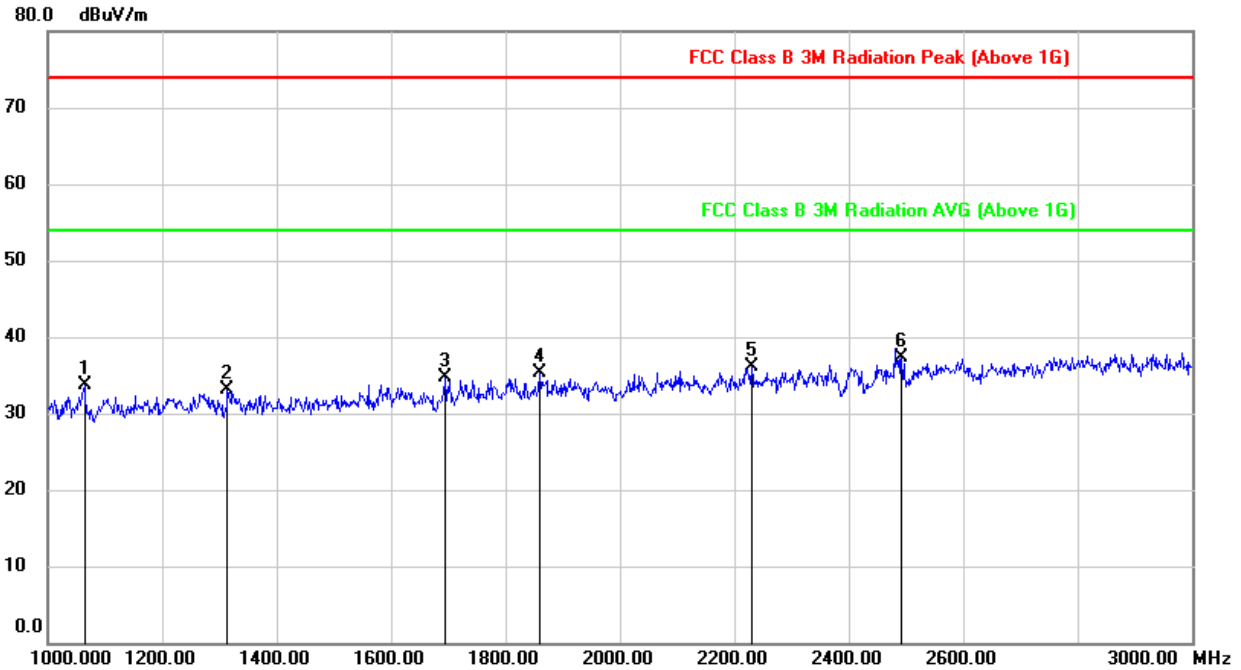

No.	Frequency (MHz)	Reading (dBuV)	Correct (dB/m)	Result (dBuV)	Limit (dBuV)	Margin (dB)	Remark
1	1064.000	46.90	-13.21	33.69	74.00	-40.31	peak
2	1314.000	44.99	-11.85	33.14	74.00	-40.86	peak
3	1694.000	45.26	-10.61	34.65	74.00	-39.35	peak
4	1860.000	44.74	-9.46	35.28	74.00	-38.72	peak
5	2230.000	43.98	-7.91	36.07	74.00	-37.93	peak
6	2492.000	43.58	-6.23	37.35	74.00	-36.65	peak

- Note: 1. Peak Result = Reading Level + Correct Factor.
 2. If Peak Result complies with AV limit, AV Result is deemed to comply with AV limit.
 3. Peak: Peak detector.
 4. The Band Reject filter loss factor already add into the correct factor.
 5. Proper operation of the transmitter prior to adding the filter to the measurement chain.



HARMONICS AND SPURIOUS EMISSIONS (HIGH CHANNEL, VERTICAL)

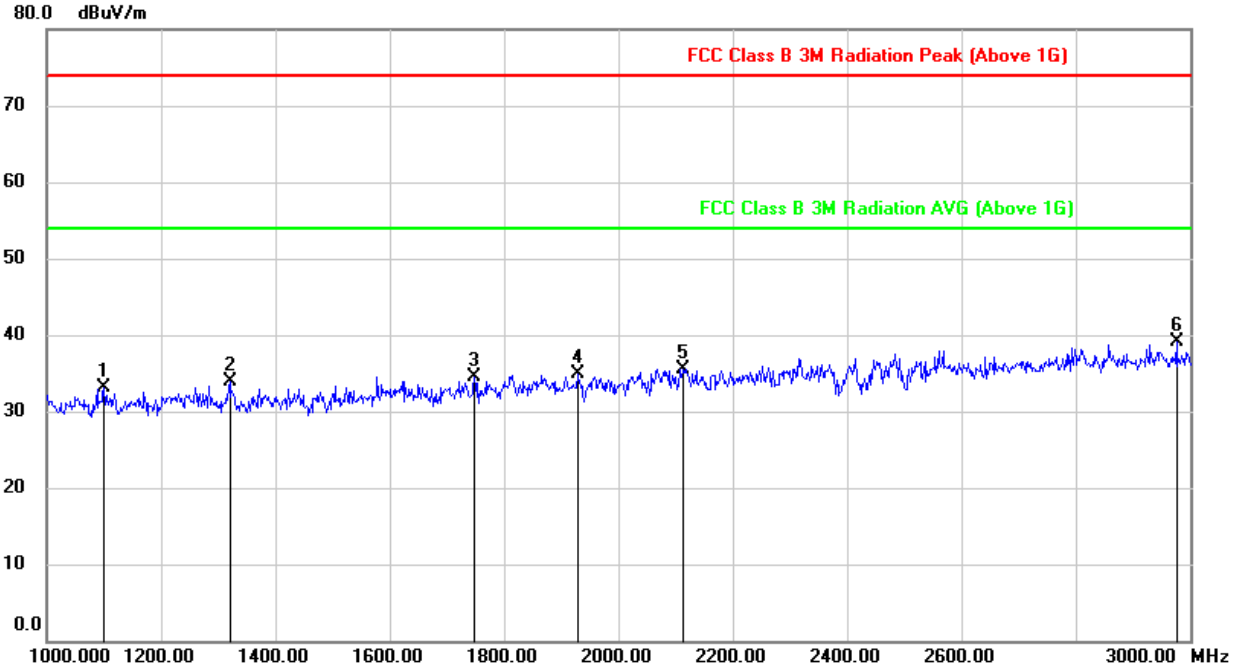

No.	Frequency (MHz)	Reading (dBuV)	Correct (dB/m)	Result (dBuV)	Limit (dBuV)	Margin (dB)	Remark
1	1100.000	46.28	-13.14	33.14	74.00	-40.86	peak
2	1320.000	45.69	-11.86	33.83	74.00	-40.17	peak
3	1748.000	44.71	-10.13	34.58	74.00	-39.42	peak
4	1928.000	44.31	-9.37	34.94	74.00	-39.06	peak
5	2112.000	43.98	-8.53	35.45	74.00	-38.55	peak
6	2976.000	43.58	-4.43	39.15	74.00	-34.85	peak

- Note: 1. Peak Result = Reading Level + Correct Factor.
 2. If Peak Result complies with AV limit, AV Result is deemed to comply with AV limit.
 3. Peak: Peak detector.
 4. The Band Reject filter loss factor already add into the correct factor.
 5. Proper operation of the transmitter prior to adding the filter to the measurement chain.



9.3.3. 802.11n HT20 MIMO MODE

2TX MODE (WORST-CASE CONFIGURATION)

HARMONICS AND SPURIOUS EMISSIONS (LOW CHANNEL, HORIZONTAL)

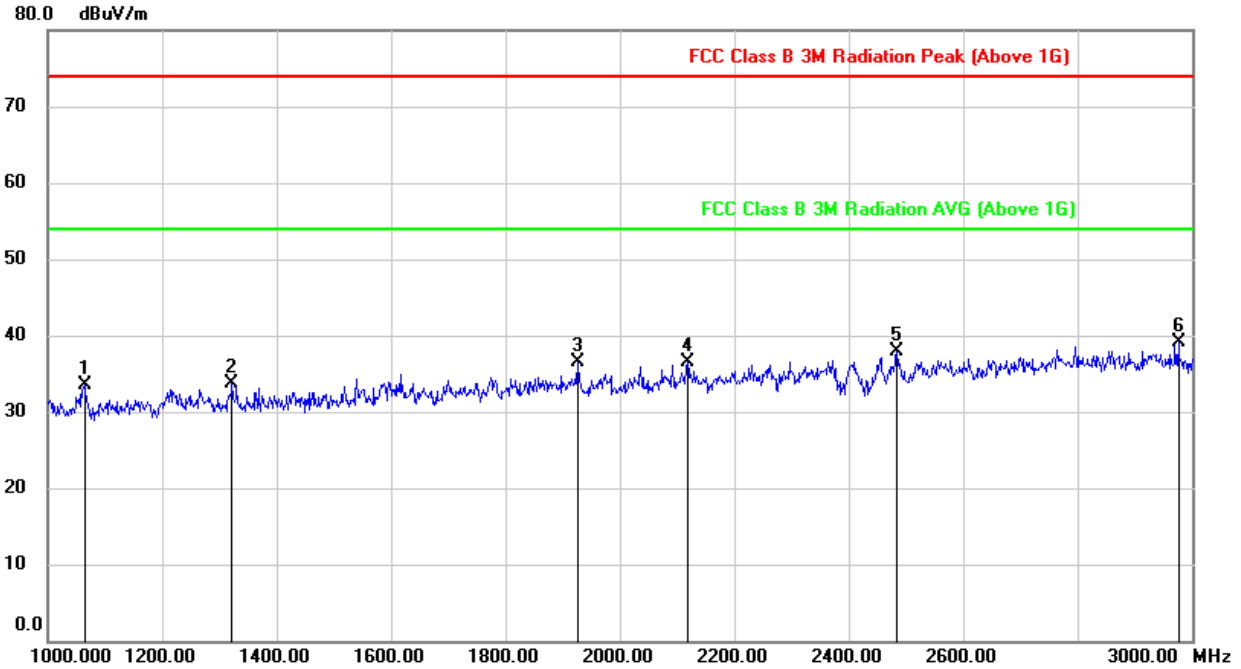

No.	Frequency (MHz)	Reading (dBuV)	Correct (dB/m)	Result (dBuV)	Limit (dBuV)	Margin (dB)	Remark
1	1064.000	46.78	-13.21	33.57	74.00	-40.43	peak
2	1322.000	45.47	-11.86	33.61	74.00	-40.39	peak
3	1926.000	45.84	-9.37	36.47	74.00	-37.53	peak
4	2118.000	45.06	-8.50	36.56	74.00	-37.44	peak
5	2484.000	44.23	-6.30	37.93	74.00	-36.07	peak
6	2976.000	43.49	-4.43	39.06	74.00	-34.94	peak

- Note: 1. Peak Result = Reading Level + Correct Factor.
 2. If Peak Result complies with AV limit, AV Result is deemed to comply with AV limit.
 3. Peak: Peak detector.
 4. The Band Reject filter loss factor already add into the correct factor.
 5. Proper operation of the transmitter prior to adding the filter to the measurement chain.



HARMONICS AND SPURIOUS EMISSIONS (LOW CHANNEL, VERTICAL)

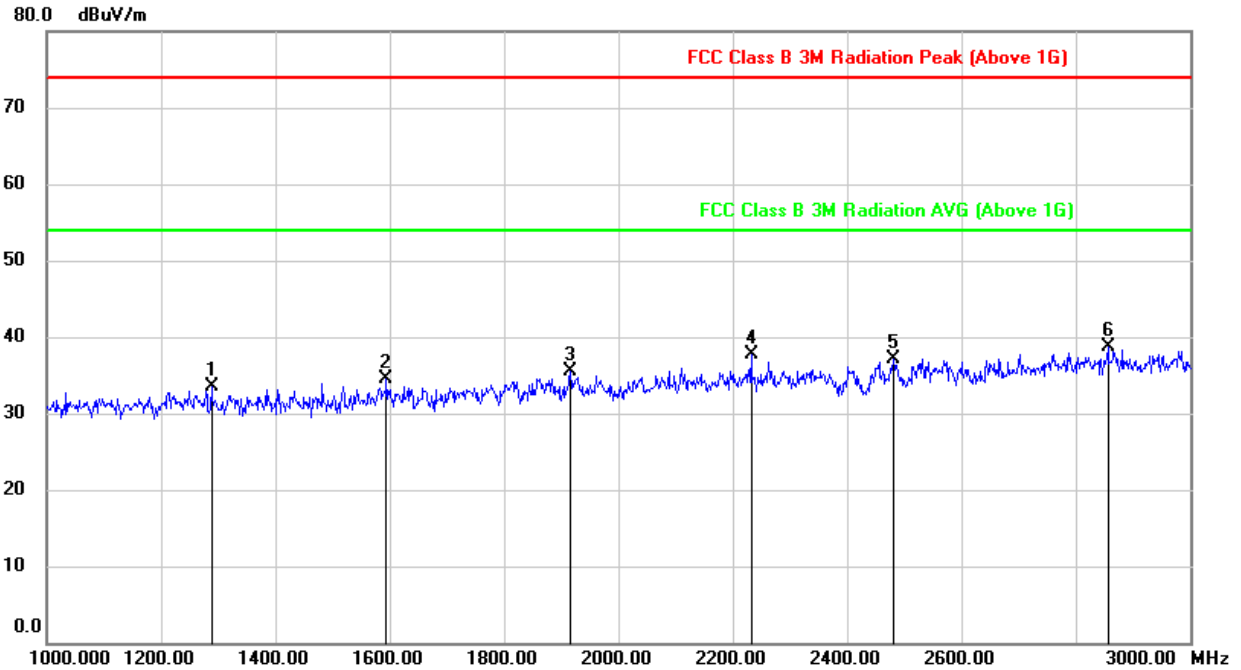

No.	Frequency (MHz)	Reading (dBuV)	Correct (dB/m)	Result (dBuV)	Limit (dBuV)	Margin (dB)	Remark
1	1288.000	45.39	-11.89	33.50	74.00	-40.50	peak
2	1594.000	45.40	-10.88	34.52	74.00	-39.48	peak
3	1916.000	44.94	-9.36	35.58	74.00	-38.42	peak
4	2232.000	45.67	-7.89	37.78	74.00	-36.22	peak
5	2480.000	43.48	-6.34	37.14	74.00	-36.86	peak
6	2856.000	43.73	-4.99	38.74	74.00	-35.26	peak

- Note: 1. Peak Result = Reading Level + Correct Factor.
 2. If Peak Result complies with AV limit, AV Result is deemed to comply with AV limit.
 3. Peak: Peak detector.
 4. The Band Reject filter loss factor already add into the correct factor.
 5. Proper operation of the transmitter prior to adding the filter to the measurement chain.



HARMONICS AND SPURIOUS EMISSIONS (MID CHANNEL, HORIZONTAL)

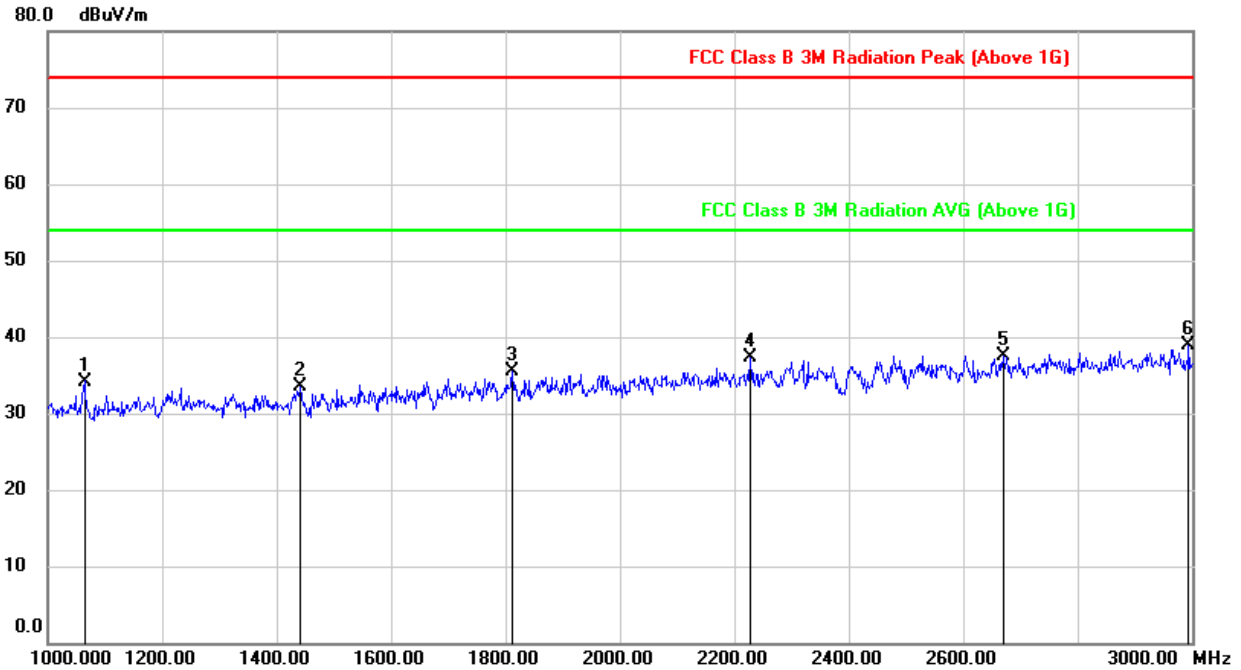

No.	Frequency (MHz)	Reading (dBuV)	Correct (dB/m)	Result (dBuV)	Limit (dBuV)	Margin (dB)	Remark
1	1064.000	47.41	-13.21	34.20	74.00	-39.80	peak
2	1442.000	45.28	-11.84	33.44	74.00	-40.56	peak
3	1812.000	45.09	-9.58	35.51	74.00	-38.49	peak
4	2228.000	45.22	-7.92	37.30	74.00	-36.70	peak
5	2670.000	43.69	-6.16	37.53	74.00	-36.47	peak
6	2994.000	43.30	-4.34	38.96	74.00	-35.04	peak

- Note: 1. Peak Result = Reading Level + Correct Factor.
 2. If Peak Result complies with AV limit, AV Result is deemed to comply with AV limit.
 3. Peak: Peak detector.
 4. The Band Reject filter loss factor already add into the correct factor.
 5. Proper operation of the transmitter prior to adding the filter to the measurement chain.



HARMONICS AND SPURIOUS EMISSIONS (MID CHANNEL, VERTICAL)

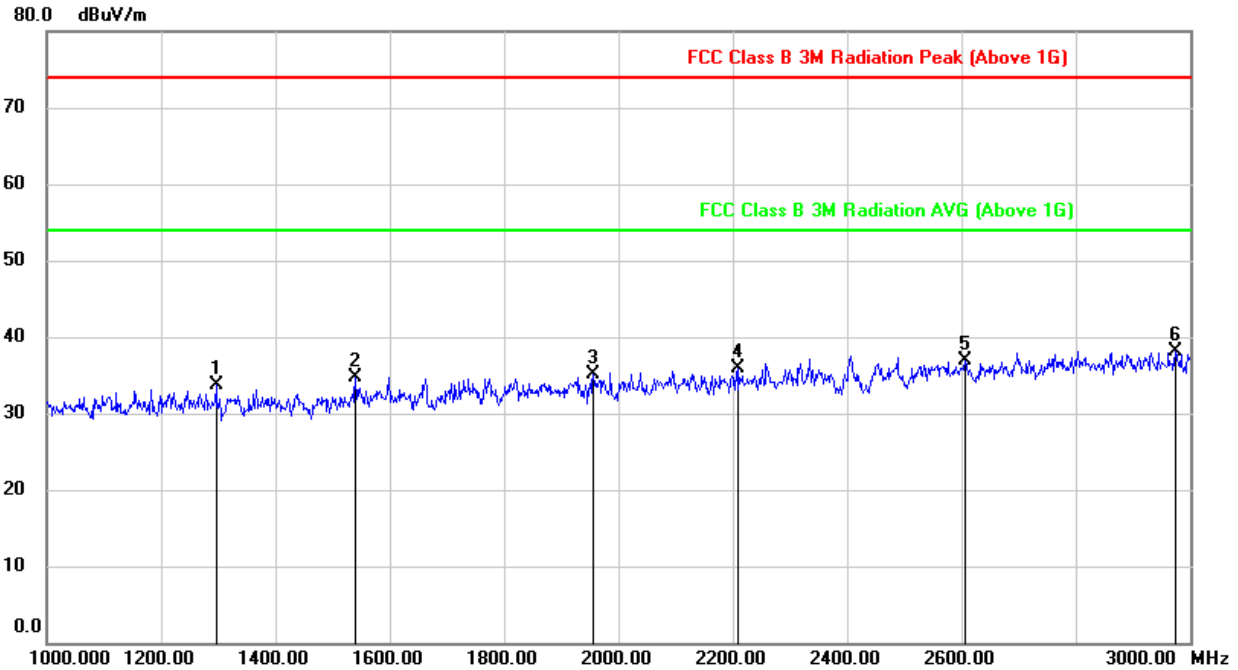

No.	Frequency (MHz)	Reading (dBuV)	Correct (dB/m)	Result (dBuV)	Limit (dBuV)	Margin (dB)	Remark
1	1296.000	45.62	-11.87	33.75	74.00	-40.25	peak
2	1540.000	46.13	-11.39	34.74	74.00	-39.26	peak
3	1956.000	44.52	-9.40	35.12	74.00	-38.88	peak
4	2210.000	43.87	-8.03	35.84	74.00	-38.16	peak
5	2606.000	43.40	-6.55	36.85	74.00	-37.15	peak
6	2974.000	42.50	-4.43	38.07	74.00	-35.93	peak

- Note: 1. Peak Result = Reading Level + Correct Factor.
 2. If Peak Result complies with AV limit, AV Result is deemed to comply with AV limit.
 3. Peak: Peak detector.
 4. The Band Reject filter loss factor already add into the correct factor.
 5. Proper operation of the transmitter prior to adding the filter to the measurement chain.



HARMONICS AND SPURIOUS EMISSIONS (HIGH CHANNEL, HORIZONTAL)

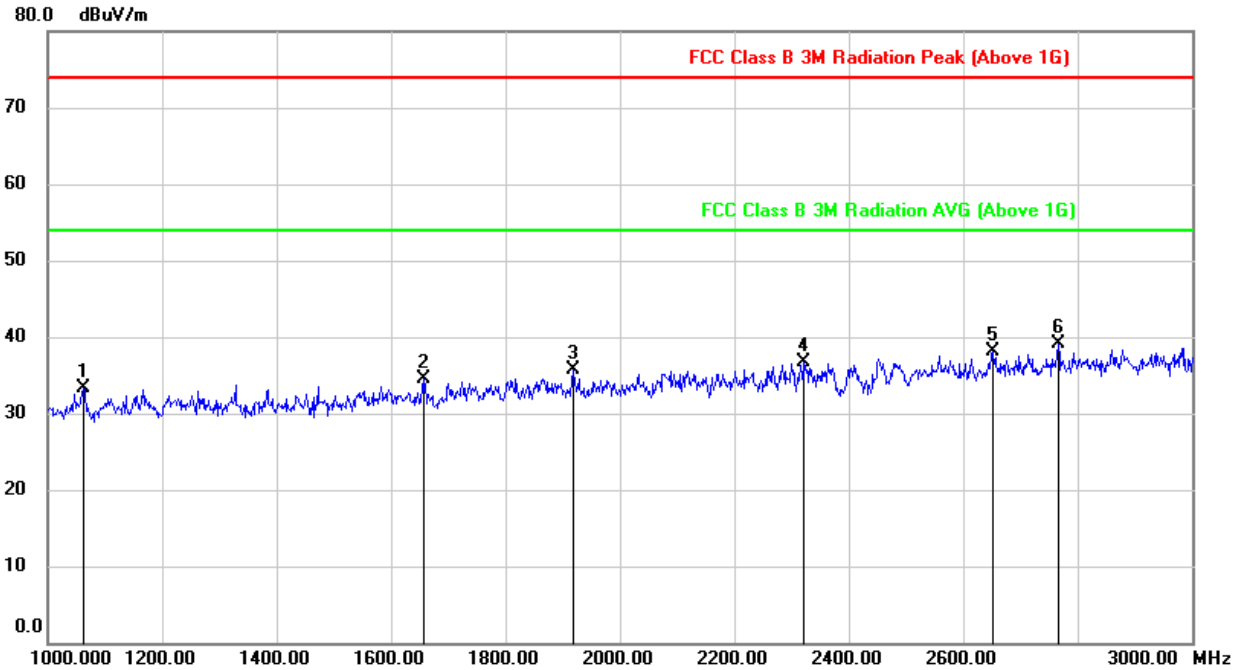

No.	Frequency (MHz)	Reading (dBuV)	Correct (dB/m)	Result (dBuV)	Limit (dBuV)	Margin (dB)	Remark
1	1062.000	46.55	-13.23	33.32	74.00	-40.68	peak
2	1656.000	45.23	-10.71	34.52	74.00	-39.48	peak
3	1918.000	45.07	-9.36	35.71	74.00	-38.29	peak
4	2320.000	44.01	-7.38	36.63	74.00	-37.37	peak
5	2652.000	44.40	-6.26	38.14	74.00	-35.86	peak
6	2766.000	44.60	-5.52	39.08	74.00	-34.92	peak

- Note: 1. Peak Result = Reading Level + Correct Factor.
 2. If Peak Result complies with AV limit, AV Result is deemed to comply with AV limit.
 3. Peak: Peak detector.
 4. The Band Reject filter loss factor already add into the correct factor.
 5. Proper operation of the transmitter prior to adding the filter to the measurement chain.



HARMONICS AND SPURIOUS EMISSIONS (HIGH CHANNEL, VERTICAL)

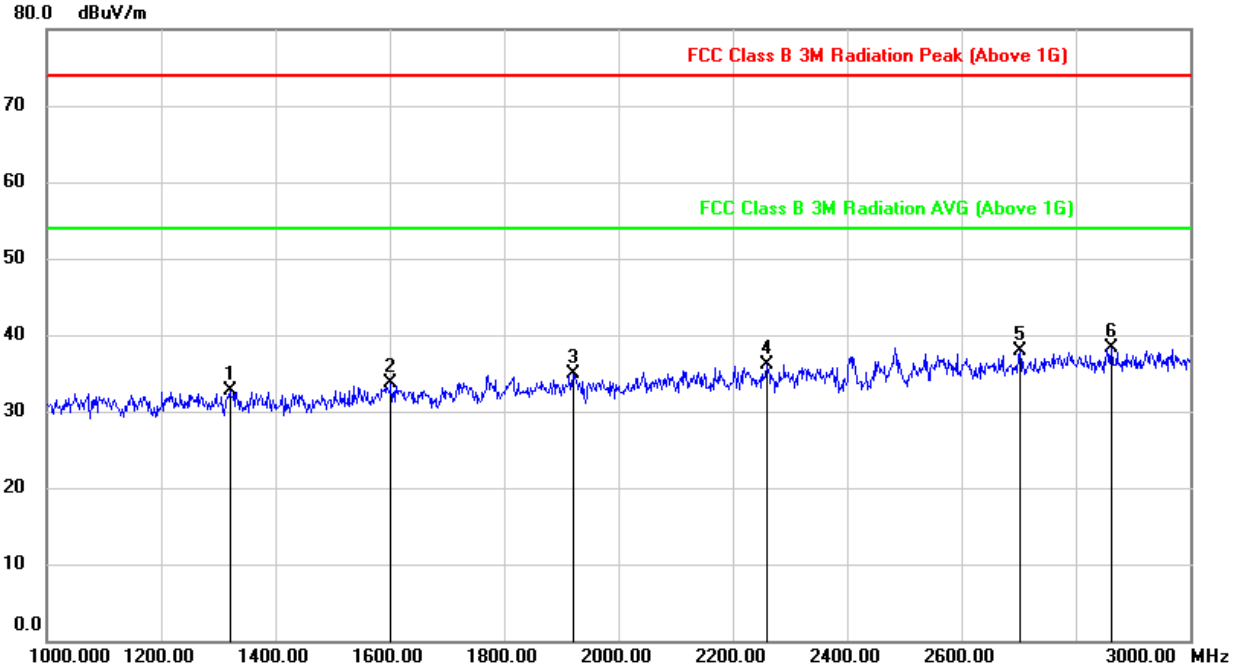

No.	Frequency (MHz)	Reading (dBuV)	Correct (dB/m)	Result (dBuV)	Limit (dBuV)	Margin (dB)	Remark
1	1320.000	44.65	-11.86	32.79	74.00	-41.21	peak
2	1602.000	44.49	-10.82	33.67	74.00	-40.33	peak
3	1920.000	44.20	-9.36	34.84	74.00	-39.16	peak
4	2260.000	43.78	-7.72	36.06	74.00	-37.94	peak
5	2702.000	43.89	-5.96	37.93	74.00	-36.07	peak
6	2862.000	43.23	-4.95	38.28	74.00	-35.72	peak

- Note: 1. Peak Result = Reading Level + Correct Factor.
 2. If Peak Result complies with AV limit, AV Result is deemed to comply with AV limit.
 3. Peak: Peak detector.
 4. The Band Reject filter loss factor already add into the correct factor.
 5. Proper operation of the transmitter prior to adding the filter to the measurement chain.



9.3.4. 802.11n HT40 MIMO MODE

2TX MODE (WORST-CASE CONFIGURATION)

HARMONICS AND SPURIOUS EMISSIONS (LOW CHANNEL, HORIZONTAL)

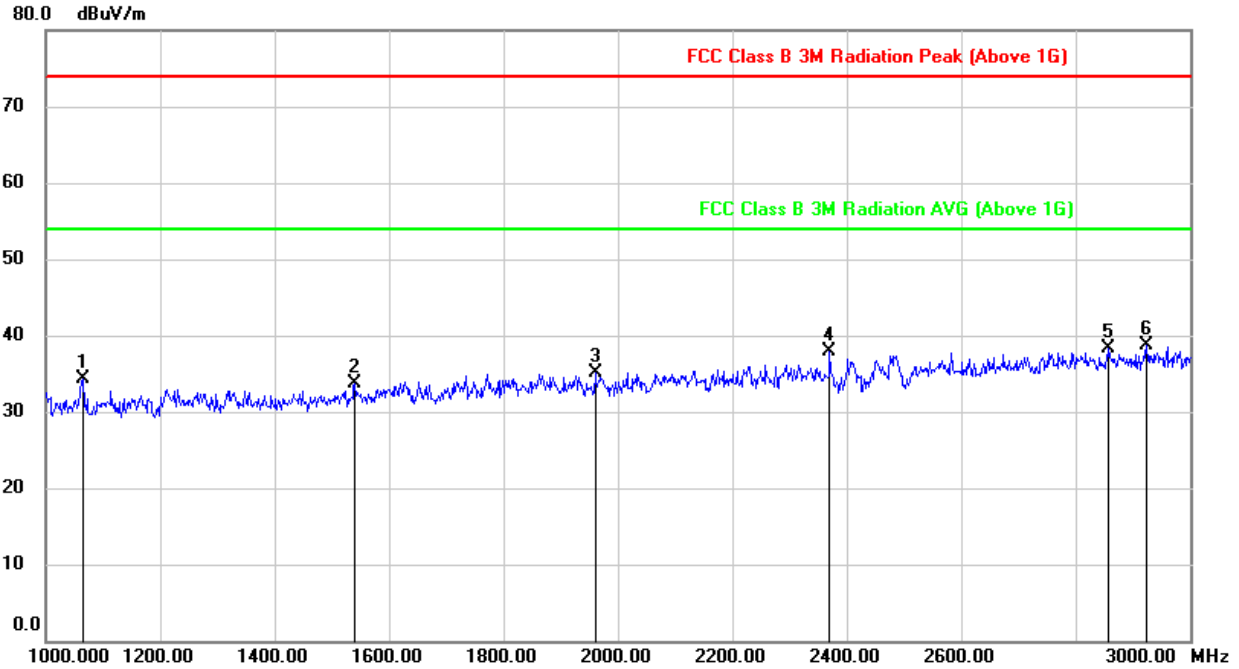

No.	Frequency (MHz)	Reading (dBuV)	Correct (dB/m)	Result (dBuV)	Limit (dBuV)	Margin (dB)	Remark
1	1066.000	47.46	-13.21	34.25	74.00	-39.75	peak
2	1540.000	45.01	-11.39	33.62	74.00	-40.38	peak
3	1960.000	44.50	-9.40	35.10	74.00	-38.90	peak
4	2370.000	44.98	-7.14	37.84	74.00	-36.16	peak
5	2858.000	43.33	-4.97	38.36	74.00	-35.64	peak
6	2924.000	43.40	-4.64	38.76	74.00	-35.24	peak

- Note:
1. Peak Result = Reading Level + Correct Factor.
 2. If Peak Result complies with AV limit, AV Result is deemed to comply with AV limit.
 3. Peak: Peak detector.
 4. The Band Reject filter loss factor already add into the correct factor.
 5. Proper operation of the transmitter prior to adding the filter to the measurement chain.



HARMONICS AND SPURIOUS EMISSIONS (LOW CHANNEL, VERTICAL)

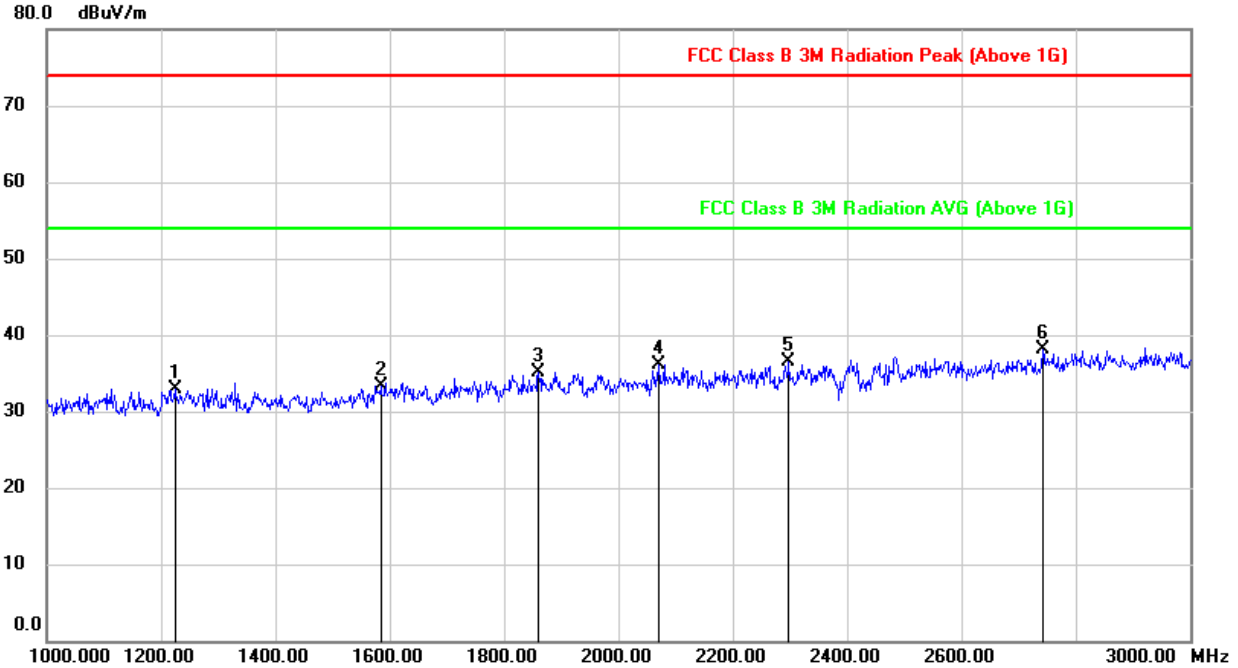

No.	Frequency (MHz)	Reading (dBuV)	Correct (dB/m)	Result (dBuV)	Limit (dBuV)	Margin (dB)	Remark
1	1224.000	45.04	-12.12	32.92	74.00	-41.08	peak
2	1584.000	44.36	-10.98	33.38	74.00	-40.62	peak
3	1860.000	44.62	-9.46	35.16	74.00	-38.84	peak
4	2070.000	45.00	-8.84	36.16	74.00	-37.84	peak
5	2298.000	43.95	-7.48	36.47	74.00	-37.53	peak
6	2742.000	43.80	-5.69	38.11	74.00	-35.89	peak

- Note: 1. Peak Result = Reading Level + Correct Factor.
 2. If Peak Result complies with AV limit, AV Result is deemed to comply with AV limit.
 3. Peak: Peak detector.
 4. The Band Reject filter loss factor already add into the correct factor.
 5. Proper operation of the transmitter prior to adding the filter to the measurement chain.



HARMONICS AND SPURIOUS EMISSIONS (MID CHANNEL, HORIZONTAL)

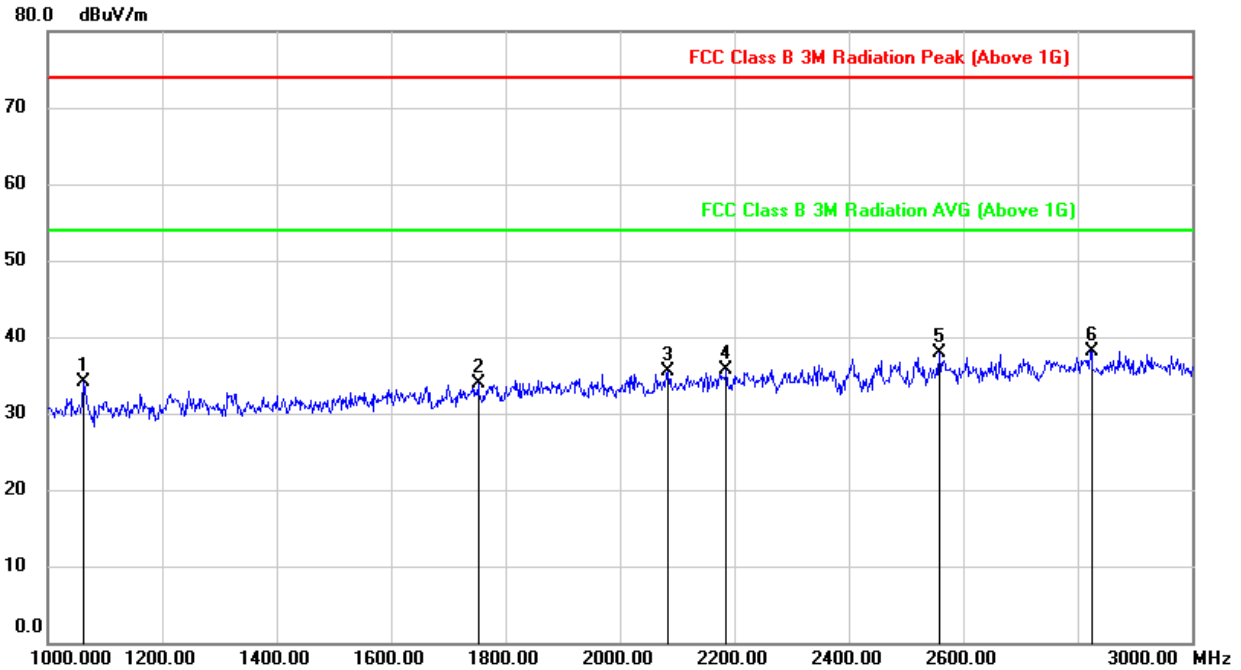

No.	Frequency (MHz)	Reading (dBuV)	Correct (dB/m)	Result (dBuV)	Limit (dBuV)	Margin (dB)	Remark
1	1062.000	47.28	-13.23	34.05	74.00	-39.95	peak
2	1752.000	43.90	-10.09	33.81	74.00	-40.19	peak
3	2084.000	44.23	-8.72	35.51	74.00	-38.49	peak
4	2186.000	43.87	-8.16	35.71	74.00	-38.29	peak
5	2558.000	44.25	-6.40	37.85	74.00	-36.15	peak
6	2824.000	43.25	-5.15	38.10	74.00	-35.90	peak

- Note:
1. Peak Result = Reading Level + Correct Factor.
 2. If Peak Result complies with AV limit, AV Result is deemed to comply with AV limit.
 3. Peak: Peak detector.
 4. The Band Reject filter loss factor already add into the correct factor.
 5. Proper operation of the transmitter prior to adding the filter to the measurement chain.



HARMONICS AND SPURIOUS EMISSIONS (MID CHANNEL, VERTICAL)

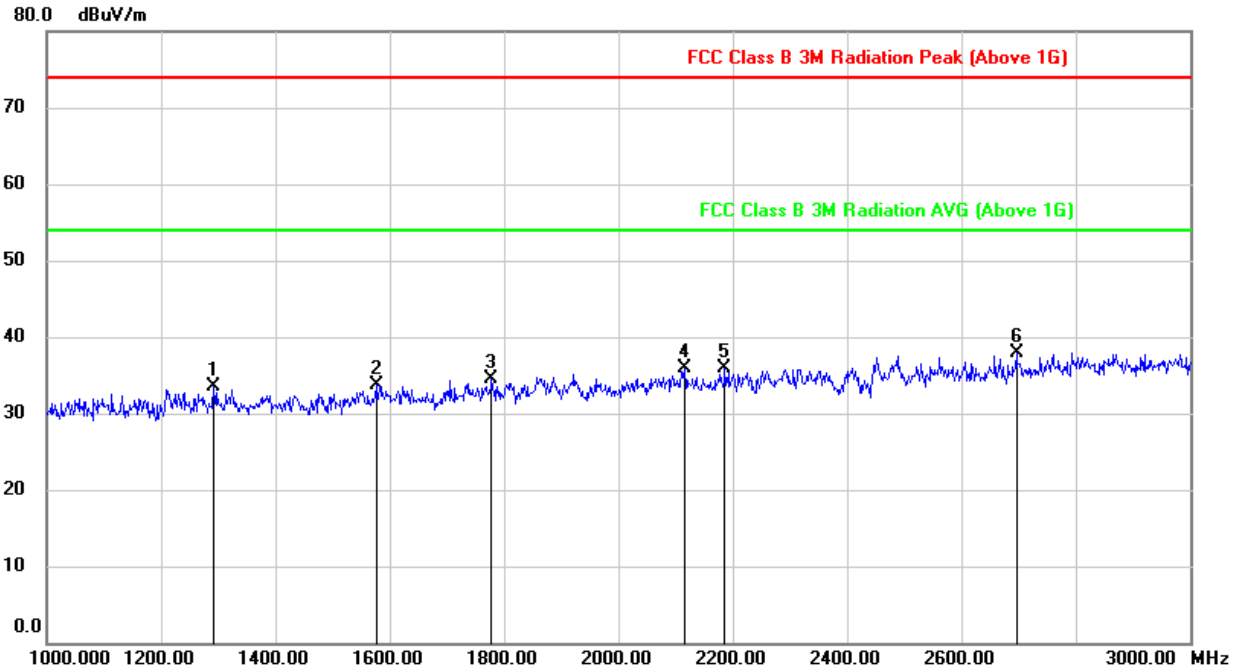

No.	Frequency (MHz)	Reading (dBuV)	Correct (dB/m)	Result (dBuV)	Limit (dBuV)	Margin (dB)	Remark
1	1292.000	45.34	-11.87	33.47	74.00	-40.53	peak
2	1576.000	44.75	-11.05	33.70	74.00	-40.30	peak
3	1778.000	44.38	-9.83	34.55	74.00	-39.45	peak
4	2116.000	44.36	-8.51	35.85	74.00	-38.15	peak
5	2186.000	44.15	-8.16	35.99	74.00	-38.01	peak
6	2696.000	43.82	-6.00	37.82	74.00	-36.18	peak

- Note: 1. Peak Result = Reading Level + Correct Factor.
 2. If Peak Result complies with AV limit, AV Result is deemed to comply with AV limit.
 3. Peak: Peak detector.
 4. The Band Reject filter loss factor already add into the correct factor.
 5. Proper operation of the transmitter prior to adding the filter to the measurement chain.



HARMONICS AND SPURIOUS EMISSIONS (HIGH CHANNEL, HORIZONTAL)

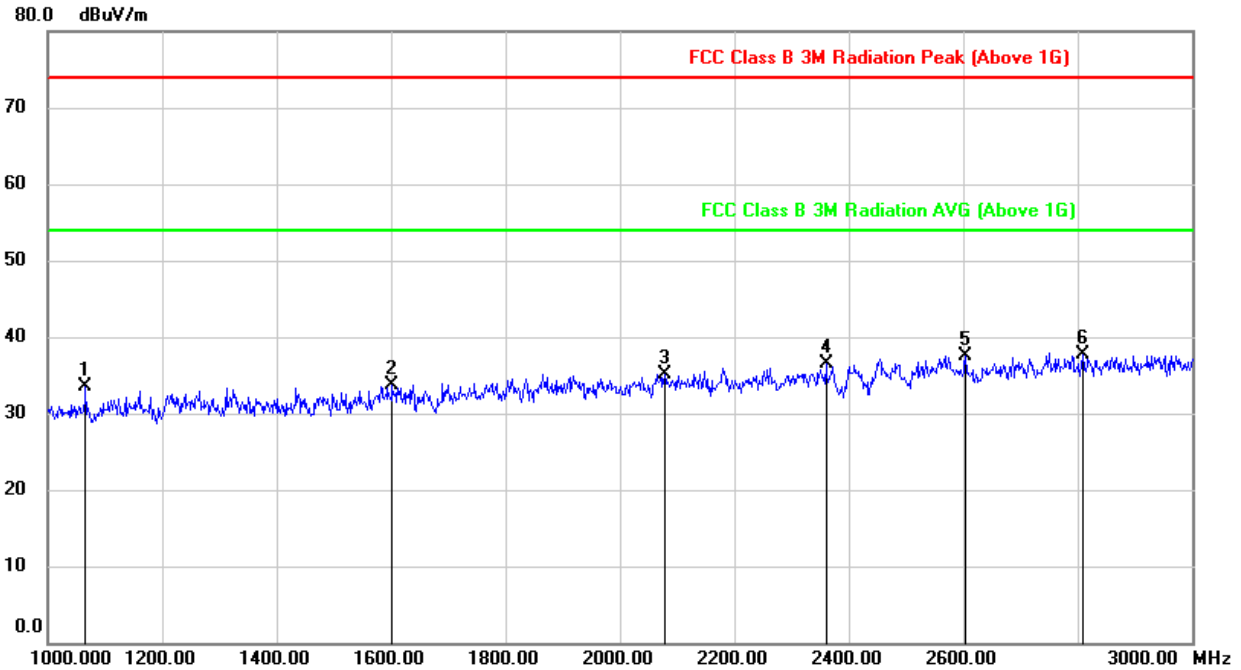

No.	Frequency (MHz)	Reading (dBuV)	Correct (dB/m)	Result (dBuV)	Limit (dBuV)	Margin (dB)	Remark
1	1066.000	46.62	-13.21	33.41	74.00	-40.59	peak
2	1602.000	44.45	-10.82	33.63	74.00	-40.37	peak
3	2078.000	43.86	-8.77	35.09	74.00	-38.91	peak
4	2360.000	43.64	-7.19	36.45	74.00	-37.55	peak
5	2604.000	44.14	-6.56	37.58	74.00	-36.42	peak
6	2810.000	43.02	-5.23	37.79	74.00	-36.21	peak

- Note: 1. Peak Result = Reading Level + Correct Factor.
 2. If Peak Result complies with AV limit, AV Result is deemed to comply with AV limit.
 3. Peak: Peak detector.
 4. The Band Reject filter loss factor already add into the correct factor.
 5. Proper operation of the transmitter prior to adding the filter to the measurement chain.



HARMONICS AND SPURIOUS EMISSIONS (HIGH CHANNEL, VERTICAL)

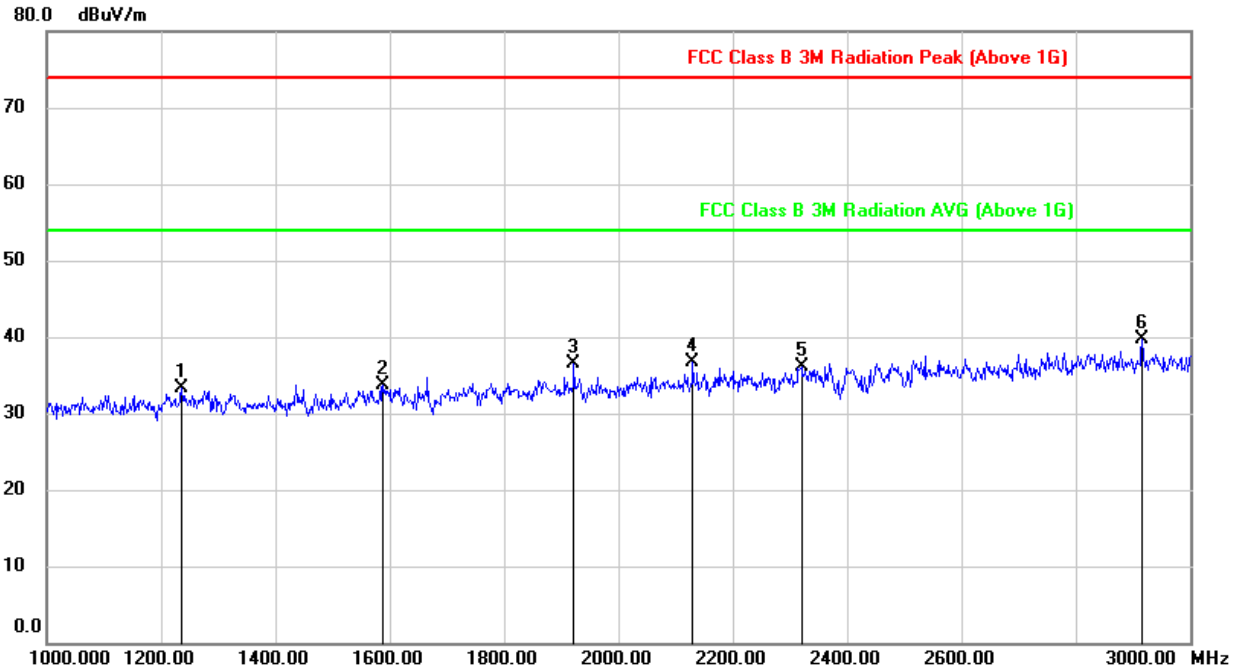

No.	Frequency (MHz)	Reading (dBuV)	Correct (dB/m)	Result (dBuV)	Limit (dBuV)	Margin (dB)	Remark
1	1236.000	45.32	-12.08	33.24	74.00	-40.76	peak
2	1588.000	44.69	-10.95	33.74	74.00	-40.26	peak
3	1922.000	45.83	-9.37	36.46	74.00	-37.54	peak
4	2130.000	45.18	-8.45	36.73	74.00	-37.27	peak
5	2320.000	43.52	-7.38	36.14	74.00	-37.86	peak
6	2916.000	44.43	-4.67	39.76	74.00	-34.24	peak

- Note: 1. Peak Result = Reading Level + Correct Factor.
 2. If Peak Result complies with AV limit, AV Result is deemed to comply with AV limit.
 3. Peak: Peak detector.
 4. The Band Reject filter loss factor already add into the correct factor.
 5. Proper operation of the transmitter prior to adding the filter to the measurement chain.



9.4. WORST-CASE CO-LOCATION

9.4.1. BT GFSK AND 802.11n HT40 MIMO MODE

SPURIOUS EMISSIONS (LOW CHANNEL, WORST-CASE CONFIGURATION, HORIZONTAL)

1-3GHz

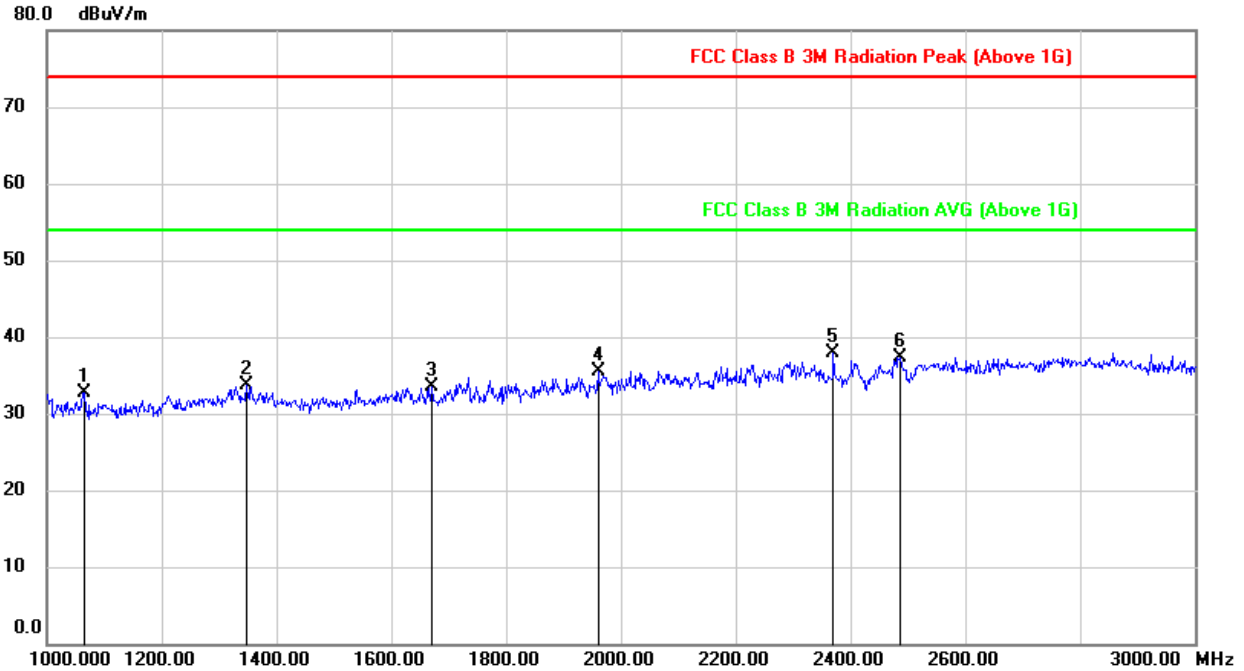

No.	Frequency (MHz)	Reading (dBuV)	Correct (dB/m)	Result (dBuV)	Limit (dBuV)	Margin (dB)	Remark
1	1066.000	45.96	-13.21	32.75	74.00	-41.25	peak
2	1348.000	45.53	-11.87	33.66	74.00	-40.34	peak
3	1670.000	44.11	-10.67	33.44	74.00	-40.56	peak
4	1960.000	45.00	-9.40	35.60	74.00	-38.40	peak
5	2370.000	44.98	-7.14	37.84	74.00	-36.16	peak
6	2486.000	43.51	-6.29	37.22	74.00	-36.78	peak

- Note: 1. Peak Result = Reading Level + Correct Factor.
 2. If Peak Result complies with AV limit, AV Result is deemed to comply with AV limit.
 3. Peak: Peak detector.
 4. The Band Reject filter loss factor already add into the correct factor.
 5. Proper operation of the transmitter prior to adding the filter to the measurement chain.



3-18GHz

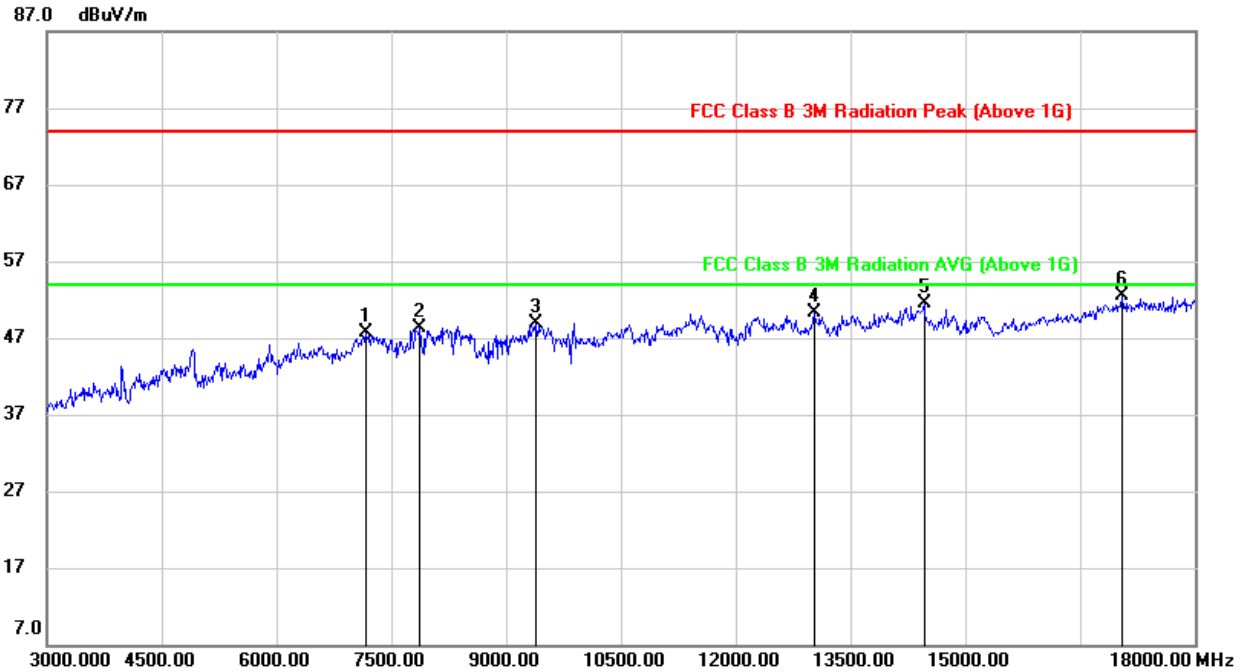

No.	Frequency (MHz)	Reading (dBuV)	Correct (dB/m)	Result (dBuV)	Limit (dBuV)	Margin (dB)	Remark
1	7170.000	40.76	6.87	47.63	74.00	-26.37	peak
2	7875.000	39.79	8.55	48.34	74.00	-25.66	peak
3	9390.000	38.75	10.24	48.99	74.00	-25.01	peak
4	13020.000	35.46	14.77	50.23	74.00	-23.77	peak
5	14460.000	35.22	16.35	51.57	74.00	-22.43	peak
6	17040.000	31.94	20.51	52.45	74.00	-21.55	peak

- Note:
1. Peak Result = Reading Level + Correct Factor.
 2. If Peak Result complies with AV limit, AV Result is deemed to comply with AV limit.
 3. Peak: Peak detector.
 4. The Band Reject filter loss factor already add into the correct factor.
 5. Proper operation of the transmitter prior to adding the filter to the measurement chain.



SPURIOUS EMISSIONS (LOW CHANNEL, WORST-CASE CONFIGURATION, VERTICAL)

1-3GHz

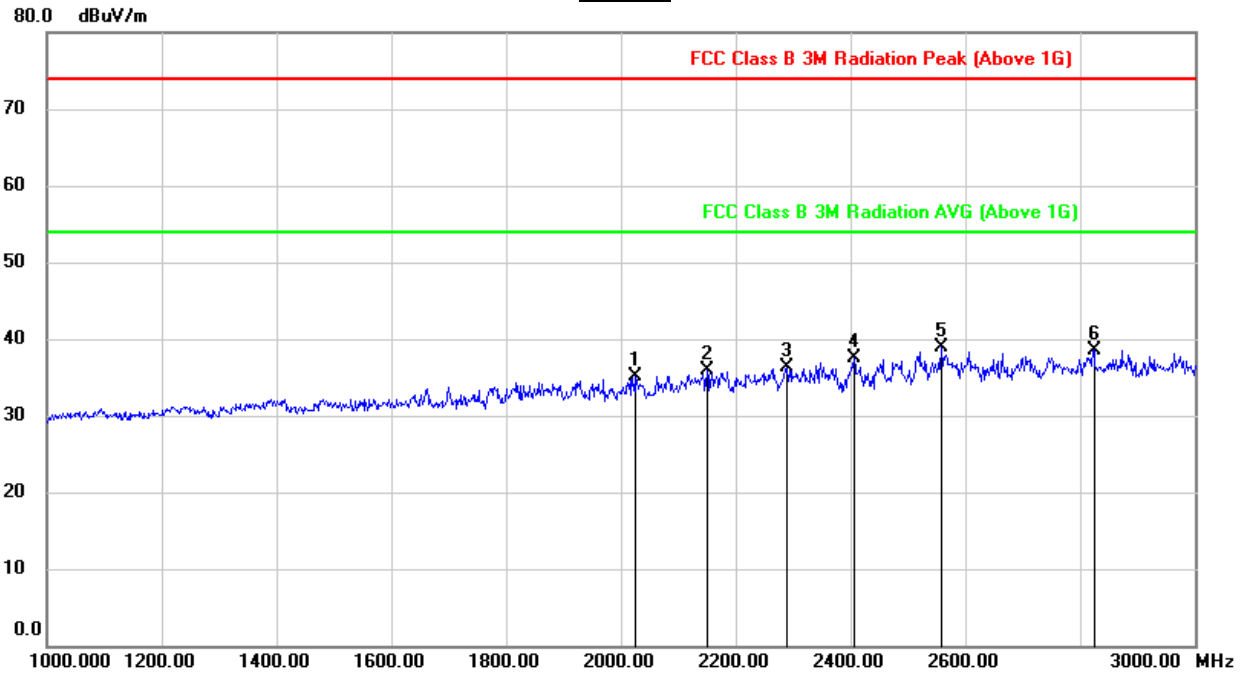

No.	Frequency (MHz)	Reading (dBuV)	Correct (dB/m)	Result (dBuV)	Limit (dBuV)	Margin (dB)	Remark
1	2026.000	44.28	-9.21	35.07	74.00	-38.93	peak
2	2150.000	44.24	-8.34	35.90	74.00	-38.10	peak
3	2288.000	43.94	-7.54	36.40	74.00	-37.60	peak
4	2406.000	44.52	-6.95	37.57	74.00	-36.43	peak
5	2558.000	45.25	-6.40	38.85	74.00	-35.15	peak
6	2824.000	43.75	-5.15	38.60	74.00	-35.40	peak

- Note:
1. Peak Result = Reading Level + Correct Factor.
 2. If Peak Result complies with AV limit, AV Result is deemed to comply with AV limit.
 3. Peak: Peak detector.
 4. The Band Reject filter loss factor already add into the correct factor.
 5. Proper operation of the transmitter prior to adding the filter to the measurement chain.



3-18GHz

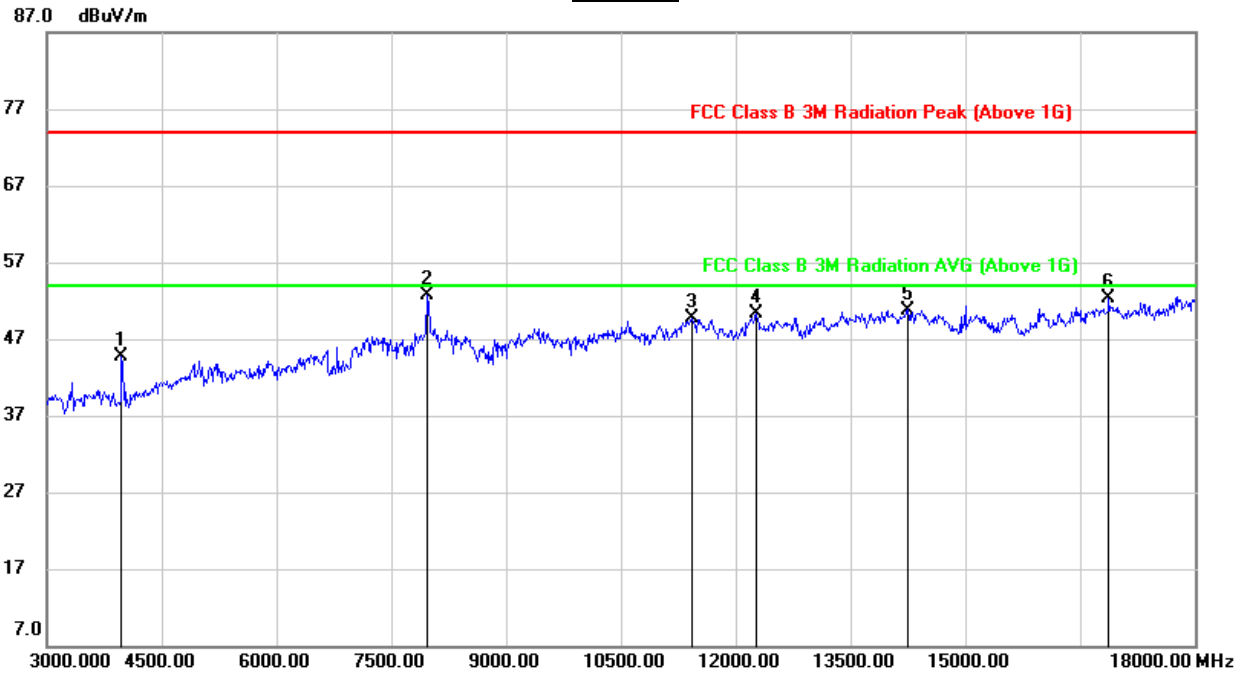

No.	Frequency (MHz)	Reading (dBuV)	Correct (dB/m)	Result (dBuV)	Limit (dBuV)	Margin (dB)	Remark
1	3975.000	47.69	-2.98	44.71	74.00	-29.29	peak
2	7965.000	44.35	8.26	52.61	74.00	-21.39	peak
3	11430.000	36.23	13.57	49.80	74.00	-24.20	peak
4	12270.000	36.02	14.34	50.36	74.00	-23.64	peak
5	14250.000	34.41	16.39	50.80	74.00	-23.20	peak
6	16875.000	32.31	19.93	52.24	74.00	-21.76	peak

- Note:
1. Peak Result = Reading Level + Correct Factor.
 2. If Peak Result complies with AV limit, AV Result is deemed to comply with AV limit.
 3. Peak: Peak detector.
 4. The Band Reject filter loss factor already add into the correct factor.
 5. Proper operation of the transmitter prior to adding the filter to the measurement chain.



RESTRICTED BANDEDGE (LOW CHANNEL, WORST-CASE CONFIGURATION, HORIZONTAL)

PEAK

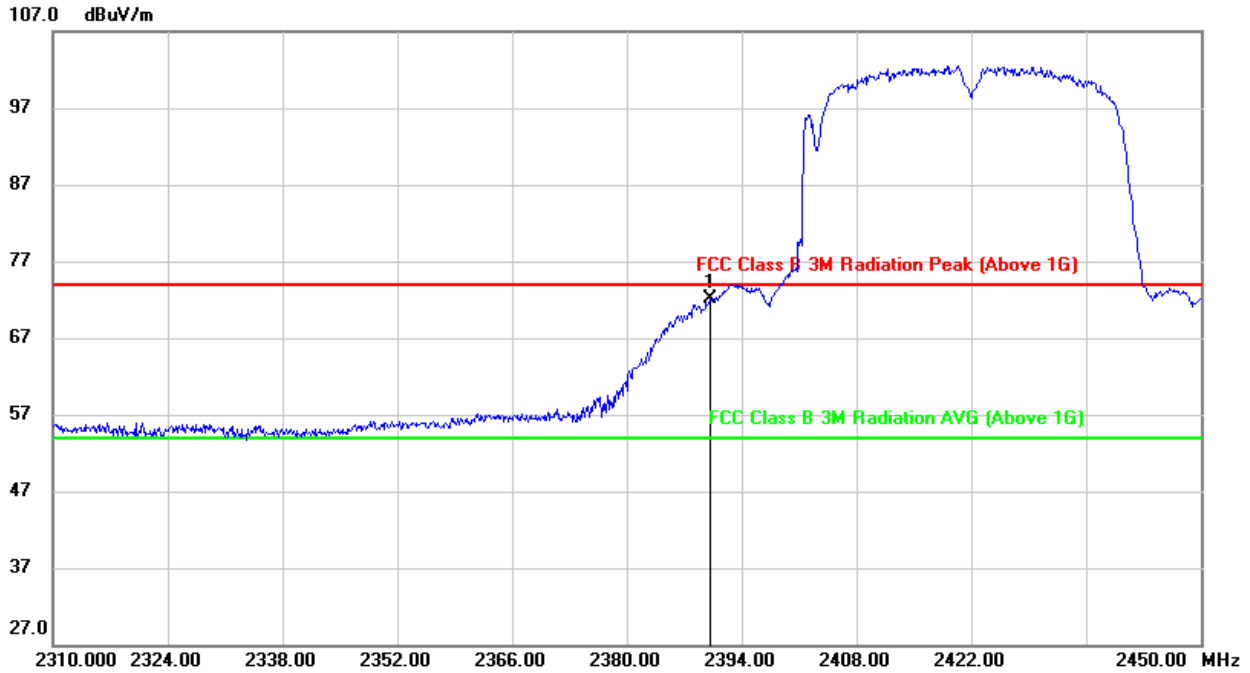

No.	Frequency (MHz)	Reading (dBuV)	Correct (dB/m)	Result (dBuV)	Limit (dBuV)	Margin (dB)	Remark
1	2390.000	39.12	32.94	72.06	74.00	-1.94	peak

- Note: 1. Measurement = Reading Level + Correct Factor.
 2. If Peak Result complies with AV limit, AV Result is deemed to comply with AV limit.
 3. Peak: Peak detector.
 4. Only the worst case emission was recorded, if it complies with the limit, the other emissions deemed to comply with the limit.



AVG

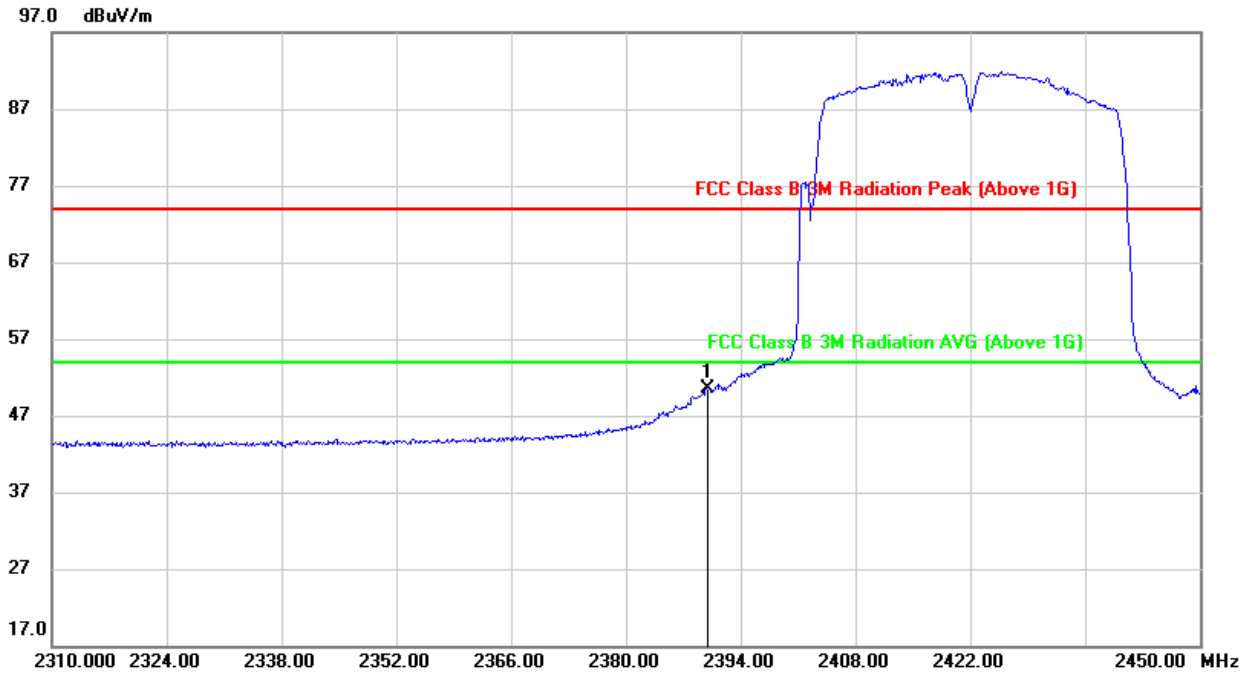

No.	Frequency (MHz)	Reading (dBuV)	Correct (dB/m)	Result (dBuV)	Limit (dBuV)	Margin (dB)	Remark
1	2390.000	17.62	32.94	50.56	54.00	-3.44	AVG

- Note:
1. Measurement = Reading Level + Correct Factor.
 2. If Peak Result complies with AV limit, AV Result is deemed to comply with AV limit.
 3. AVG: $VBW=1/T_{on}$ where: t_{on} is transmit duration.
 4. For transmit duration, please refer to clause 8.1.
 5. Only the worst case emission was recorded, if it complies with the limit, the other emissions deemed to comply with the limit.



RESTRICTED BANDEDGE (LOW CHANNEL, VERTICAL)

PEAK

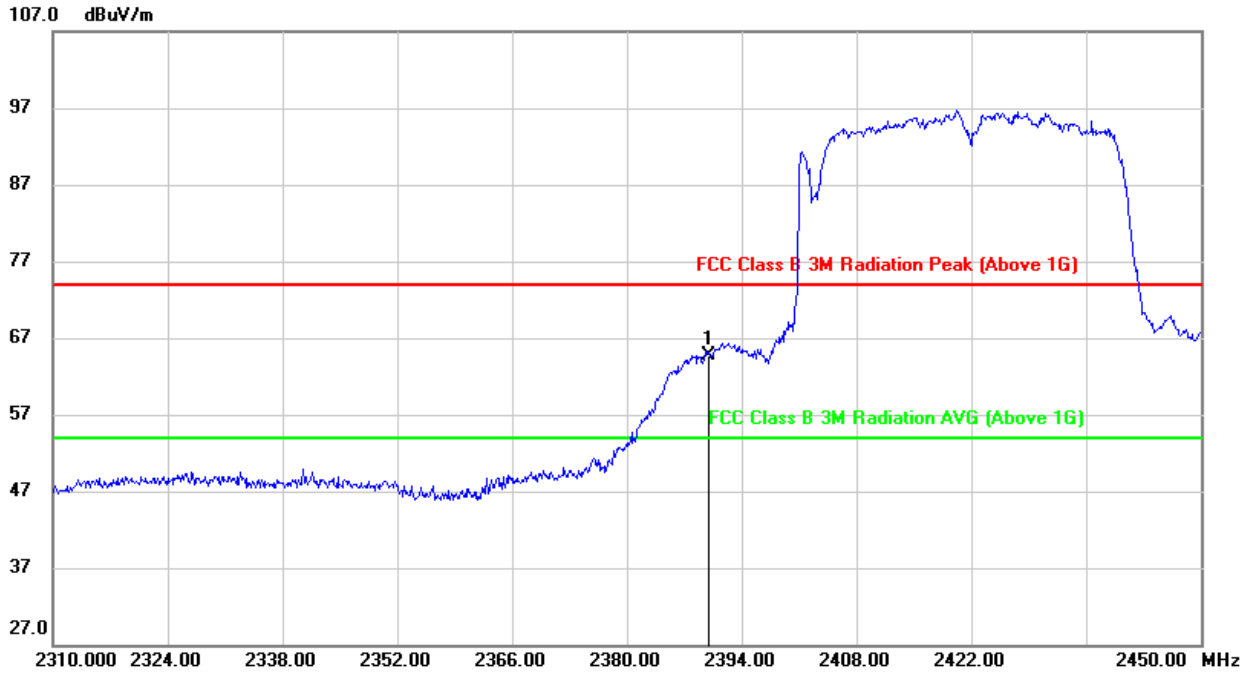

No.	Frequency (MHz)	Reading (dBuV)	Correct (dB/m)	Result (dBuV)	Limit (dBuV)	Margin (dB)	Remark
1	2390.000	31.80	32.94	64.74	74.00	-9.26	peak

- Note: 1. Measurement = Reading Level + Correct Factor.
 2. If Peak Result complies with AV limit, AV Result is deemed to comply with AV limit.
 3. Peak: Peak detector.
 4. Only the worst case emission was recorded, if it complies with the limit, the other emissions deemed to comply with the limit.



AVG

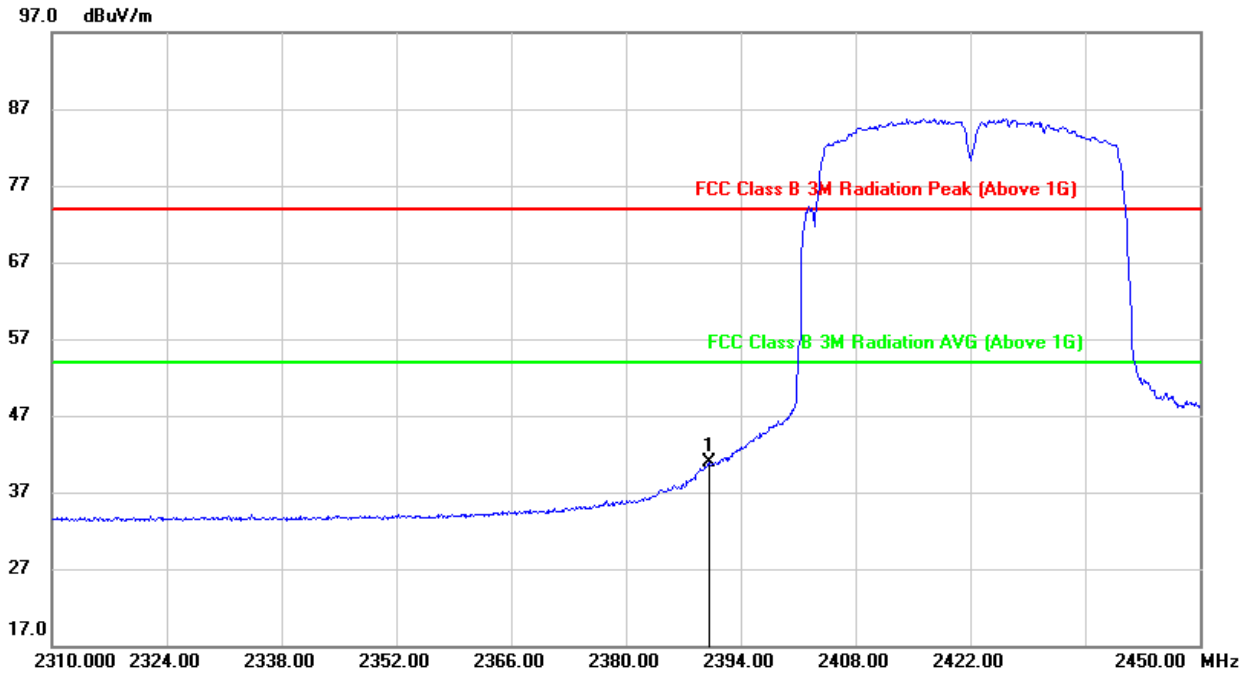

No.	Frequency (MHz)	Reading (dBuV)	Correct (dB/m)	Result (dBuV)	Limit (dBuV)	Margin (dB)	Remark
1	2390.000	7.92	32.94	40.86	54.00	-13.14	AVG

- Note:
1. Measurement = Reading Level + Correct Factor.
 2. If Peak Result complies with AV limit, AV Result is deemed to comply with AV limit.
 3. AVG: $VBW=1/Ton$ where: ton is transmit duration.
 4. For transmit duration, please refer to clause 8.1.
 5. Only the worst case emission was recorded, if it complies with the limit, the other emissions deemed to comply with the limit.



9.5. SPURIOUS EMISSIONS (18~26GHz)

9.5.1. 802.11n HT20 MIMO MODE

2TX MODE (WORST-CASE CONFIGURATION)

SPURIOUS EMISSIONS (MID CHANNEL, HORIZONTAL)

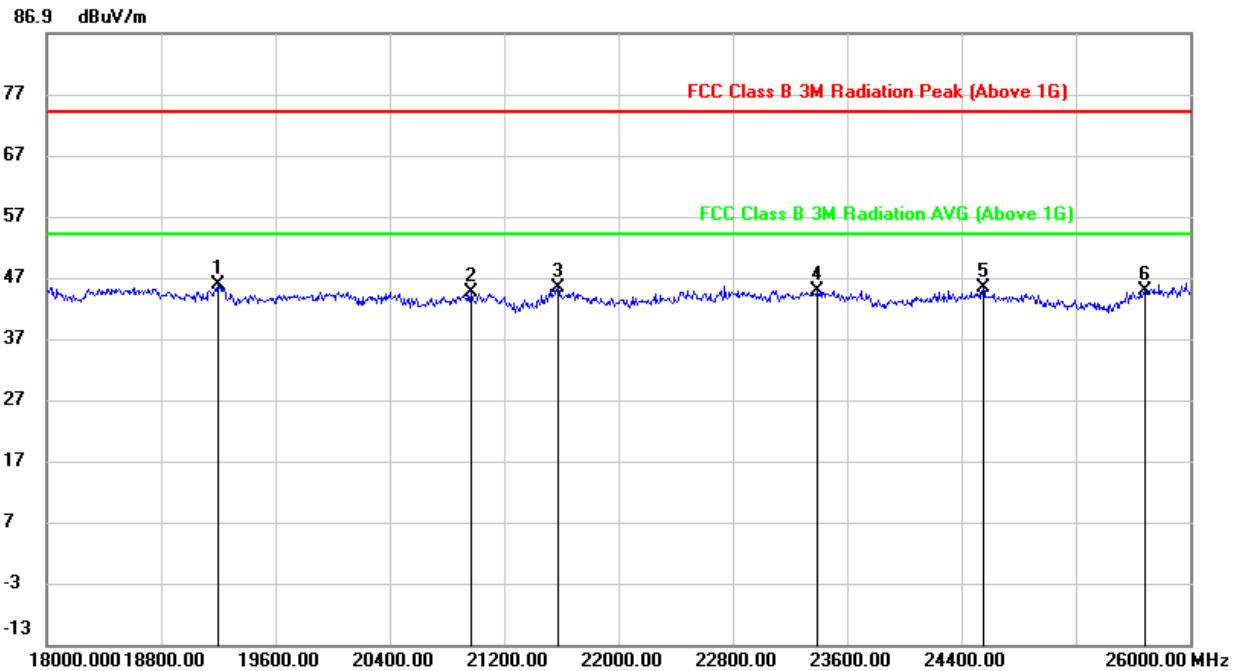

No.	Frequency (MHz)	Reading (dBuV/m)	Correct (dB/m)	Result (dBuV/m)	Limit (dBuV/m)	Margin (dB)	Remark
1	18253.289	49.50	-5.55	43.95	74.00	-30.05	peak
2	18825.911	49.01	-5.36	43.65	74.00	-30.35	peak
3	20457.304	48.93	-5.39	43.54	74.00	-30.46	peak
4	22197.394	49.99	-4.27	45.72	74.00	-28.28	peak
5	22742.711	48.46	-3.70	44.76	74.00	-29.24	peak
6	24841.078	47.85	-2.24	45.61	74.00	-28.39	peak

- Note: 1. Measurement = Reading Level + Correct Factor.
 2. If Peak Result complies with AV limit, AV Result is deemed to comply with AV limit.
 3. Peak: Peak detector.



SPURIOUS EMISSIONS (MID CHANNEL, VERTICAL)

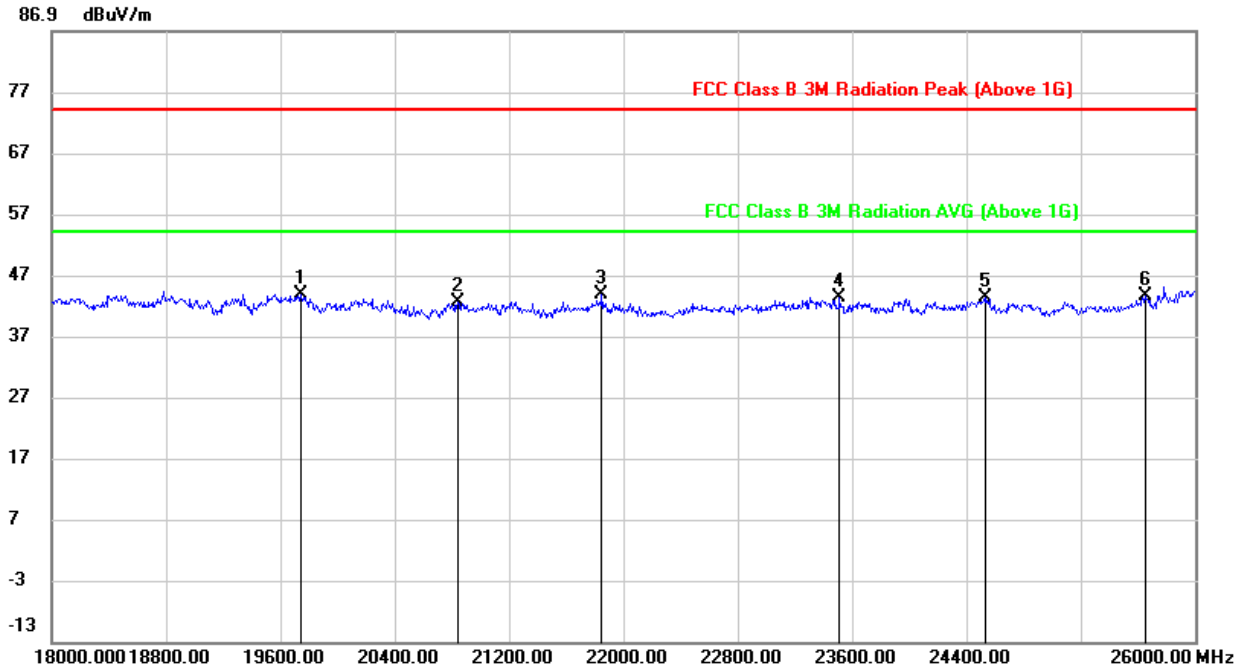

No.	Frequency (MHz)	Reading (dBuV)	Correct (dB/m)	Result (dBuV)	Limit (dBuV)	Margin (dB)	Remark
1	19744.000	48.08	-4.35	43.73	74.00	-30.27	peak
2	20840.000	47.77	-5.18	42.59	74.00	-31.41	peak
3	21848.000	49.76	-5.95	43.81	74.00	-30.19	peak
4	23512.000	48.01	-4.76	43.25	74.00	-30.75	peak
5	24528.000	45.86	-2.51	43.35	74.00	-30.65	peak
6	25648.000	45.12	-1.53	43.59	74.00	-30.41	peak

- Note: 1. Measurement = Reading Level + Correct Factor.
 2. If Peak Result complies with AV limit, AV Result is deemed to comply with AV limit.
 3. Peak: Peak detector.

Note: All test mode has been tested, only the worst data record in the report.



9.6. SPURIOUS EMISSIONS (0.03 ~ 1 GHz)

9.6.1. 802.11n HT20 MIMO MODE

2TX MODE (WORST-CASE CONFIGURATION)

SPURIOUS EMISSIONS (MID CHANNEL, HORIZONTAL)

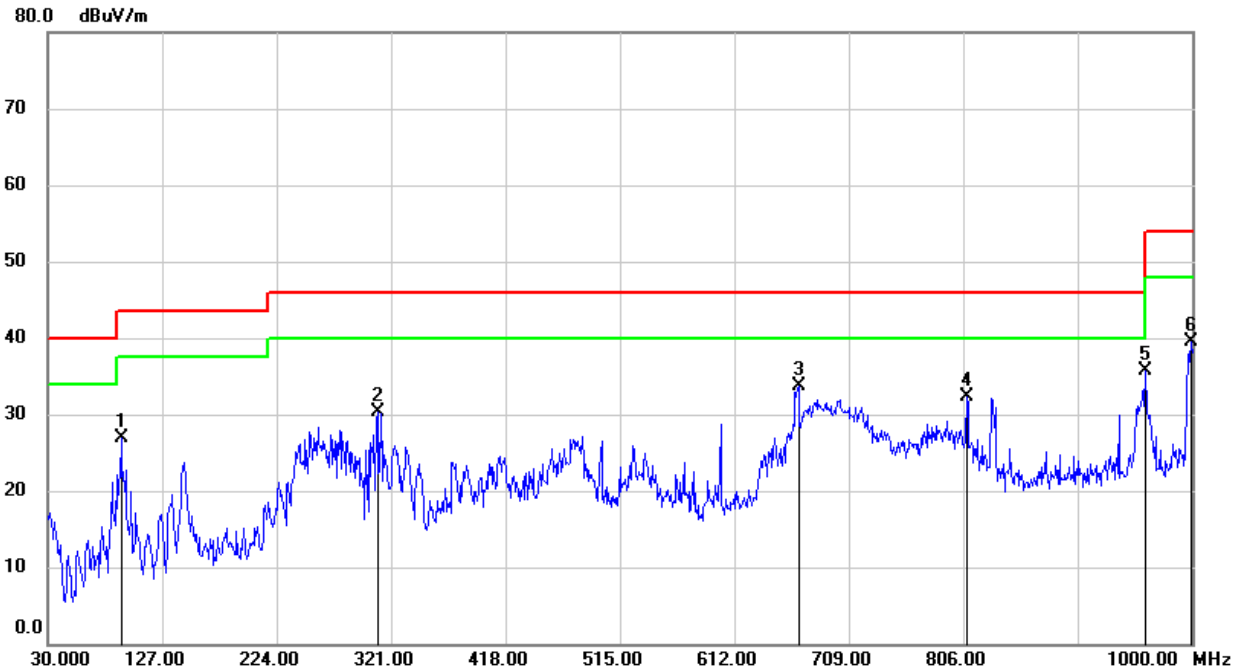

No.	Frequency (MHz)	Reading (dBuV)	Correct (dB/m)	Result (dBuV/m)	Limit (dBuV/m)	Margin (dB)	Remark
1	92.0800	48.10	-21.23	26.87	43.50	-16.63	QP
2	310.3299	44.14	-13.79	30.35	46.00	-15.65	QP
3	666.3200	41.03	-7.23	33.80	46.00	-12.20	QP
4	808.9099	37.51	-5.27	32.24	46.00	-13.76	QP
5	960.2300	39.19	-3.46	35.73	54.00	-18.27	QP
6	999.0300	42.39	-2.86	39.53	54.00	-14.47	QP

- Note: 1. Result Level = Read Level + Correct Factor.
 2. If Peak Result complies with QP limit, QP Result is deemed to comply with QP limit.
 3. Test setup: RBW: 120 kHz, VBW: 300 kHz, Sweep time: auto.



SPURIOUS EMISSIONS (MID CHANNEL, VERTICAL)

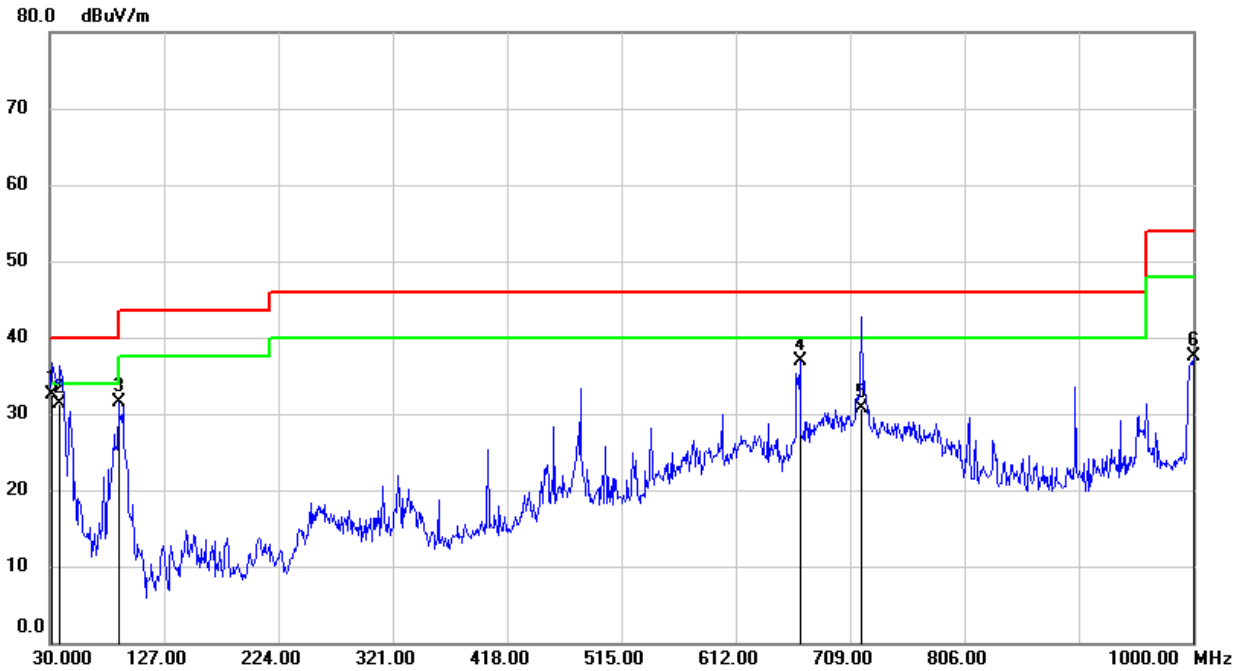

No.	Frequency (MHz)	Reading (dBuV)	Correct (dB/m)	Result (dBuV/m)	Limit (dBuV/m)	Margin (dB)	Remark
1	31.9400	49.84	-17.29	32.55	40.00	-7.45	QP
2	38.7300	49.08	-17.87	31.21	40.00	-8.79	QP
3	88.2000	52.44	-21.03	31.41	43.50	-12.09	QP
4	666.3200	44.11	-7.23	36.88	46.00	-9.12	QP
5	718.7000	36.75	-6.13	30.62	46.00	-15.38	QP
6	1000.0000	40.27	-2.84	37.43	54.00	-16.57	QP

- Note: 1. Result Level = Read Level + Correct Factor.
 2. If Peak Result complies with QP limit, QP Result is deemed to comply with QP limit.
 3. Test setup: RBW: 120 kHz, VBW: 300 kHz, Sweep time: auto

Note: All test mode has been tested, only the worst data record in the report.



9.7. SPURIOUS EMISSIONS BELOW 30M

9.7.1. 802. 11n HT20 MIMO MODE

2TX MODE (WORST-CASE CONFIGURATION)

SPURIOUS EMISSIONS (LOW CHANNEL, LOOP ANTENNA FACE ON TO THE EUT, WORST-CASE CONFIGURATION)

9kHz~ 150kHz

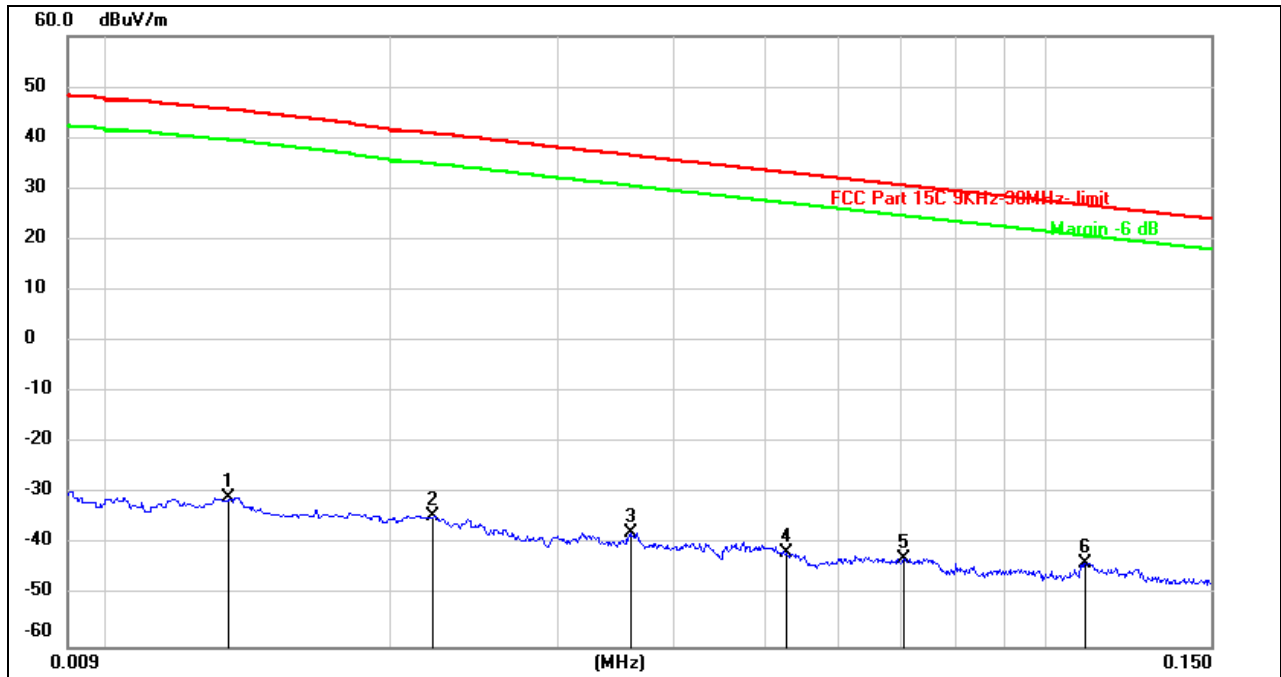

No.	Frequency (MHz)	Reading (dBuV)	Correct (dB/m)	Result (dBuV)	Limit (dBuV)	Margin (dB)	Remark
1	0.0134	70.73	-101.39	-30.66	45.55	-76.21	peak
2	0.0221	67.13	-101.35	-34.22	40.84	-75.06	peak
3	0.0359	63.72	-101.42	-37.70	36.59	-74.29	peak
4	0.0529	59.80	-101.49	-41.69	33.16	-74.85	peak
5	0.0704	58.92	-101.57	-42.65	30.65	-73.30	peak
6	0.1101	58.25	-101.77	-43.52	26.77	-70.29	peak

Note: 1. Measurement = Reading Level + Correct Factor.

2. If Peak Result complies with AV and QP limit, AV and QP Result are deemed to comply with AV limit.

3. All 3 polarizations(Horizontal, Face-on and Face-off) of the loop antenna had been tested, but only the worst data recorded in the report.



150kHz ~ 0.49MHz

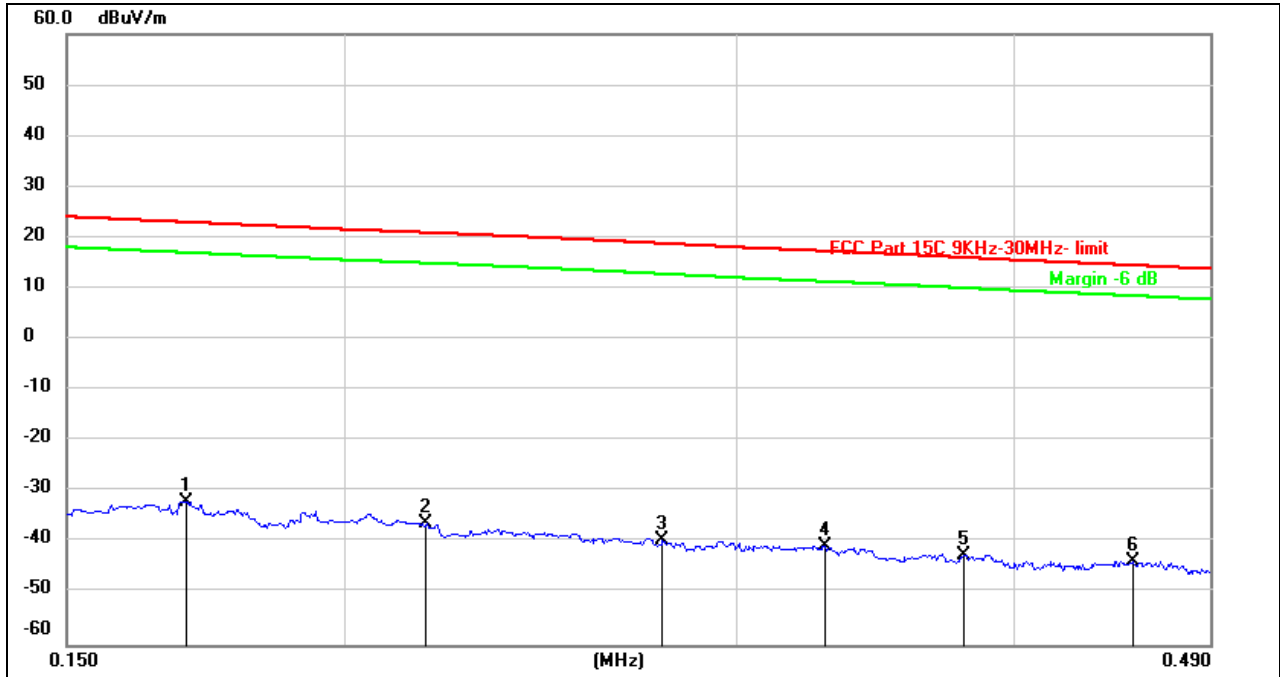

No.	Frequency (MHz)	Reading (dBuV)	Correct (dB/m)	Result (dBuV)	Limit (dBuV)	Margin (dB)	Remark
1	0.1696	69.74	-101.67	-31.93	23.02	-54.95	peak
2	0.2177	65.62	-101.75	-36.13	20.96	-57.09	peak
3	0.2782	62.29	-101.83	-39.54	18.83	-58.37	peak
4	0.3286	61.21	-101.88	-40.67	17.34	-58.01	peak
5	0.3800	59.52	-101.94	-42.42	16.06	-58.48	peak
6	0.4521	58.31	-102.01	-43.70	14.54	-58.24	peak

- Note: 1. Measurement = Reading Level + Correct Factor.
 2. If Peak Result complies with AV and QP limit, AV and QP Result are deemed to comply with AV limit.
 3. All 3 polarizations(Horizontal, Face-on and Face-off) of the loop antenna had been tested, but only the worst data recorded in the report.



0.49MHz ~ 30MHz

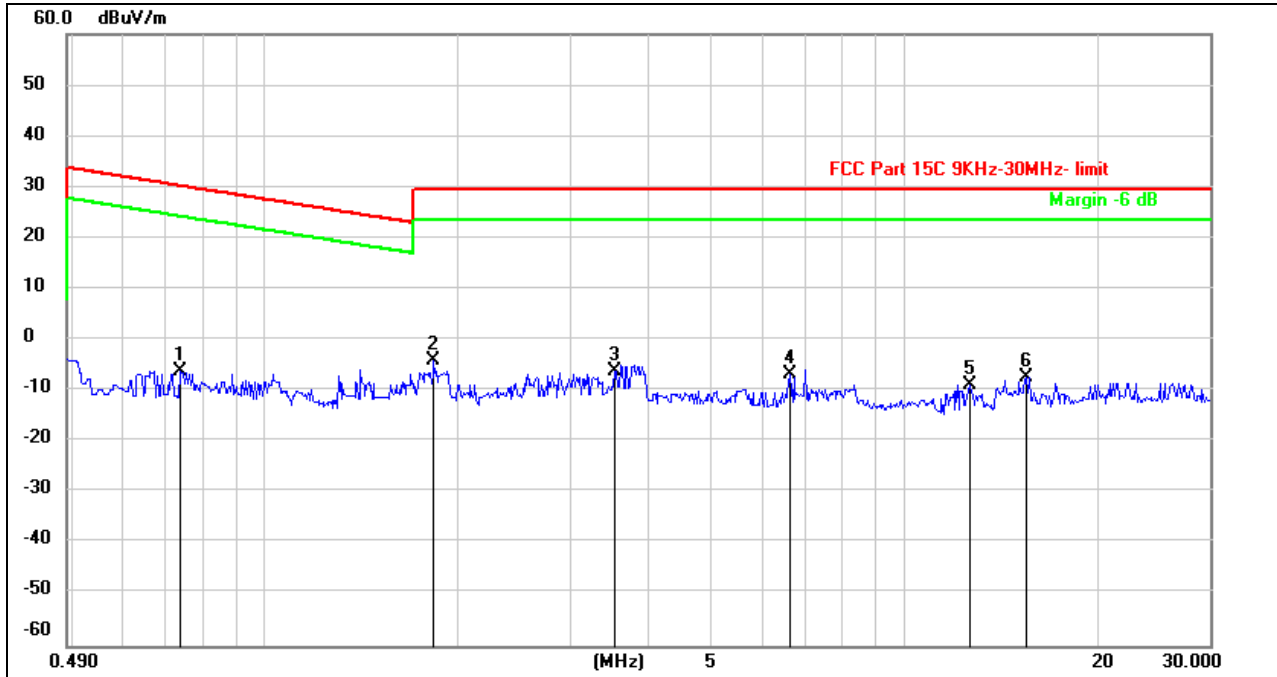

No.	Frequency (MHz)	Reading (dBuV)	Correct (dB/m)	Result (dBuV)	Limit (dBuV)	Margin (dB)	Remark
1	0.7364	55.87	-62.11	-6.24	30.28	-36.52	peak
2	1.8357	57.93	-61.89	-3.96	29.54	-33.50	peak
3	3.5295	55.19	-61.45	-6.26	29.54	-35.80	peak
4	6.6280	54.40	-61.26	-6.86	29.54	-36.40	peak
5	12.6775	51.96	-60.92	-8.96	29.54	-38.50	peak
6	15.4809	53.70	-61.00	-7.30	29.54	-36.84	peak

Note: 1. Measurement = Reading Level + Correct Factor.

2. If Peak Result complies with AV and QP limit, AV and QP Result are deemed to comply with AV limit.

3. All 3 polarizations(Horizontal, Face-on and Face-off) of the loop antenna had been tested, but only the worst data recorded in the report.

Note: All test mode has been tested, only the worst data record in the report.

10. AC POWER LINE CONDUCTED EMISSIONS

LIMITS

Please refer to CFR 47 FCC §15.207 (a) and ISED RSS-Gen Clause 8.8

FREQUENCY (MHz)	Quasi-peak	Average
0.15 -0.5	66 - 56 *	56 - 46 *
0.50 -5.0	56.00	46.00
5.0 -30.0	60.00	50.00

TEST SETUP AND PROCEDURE

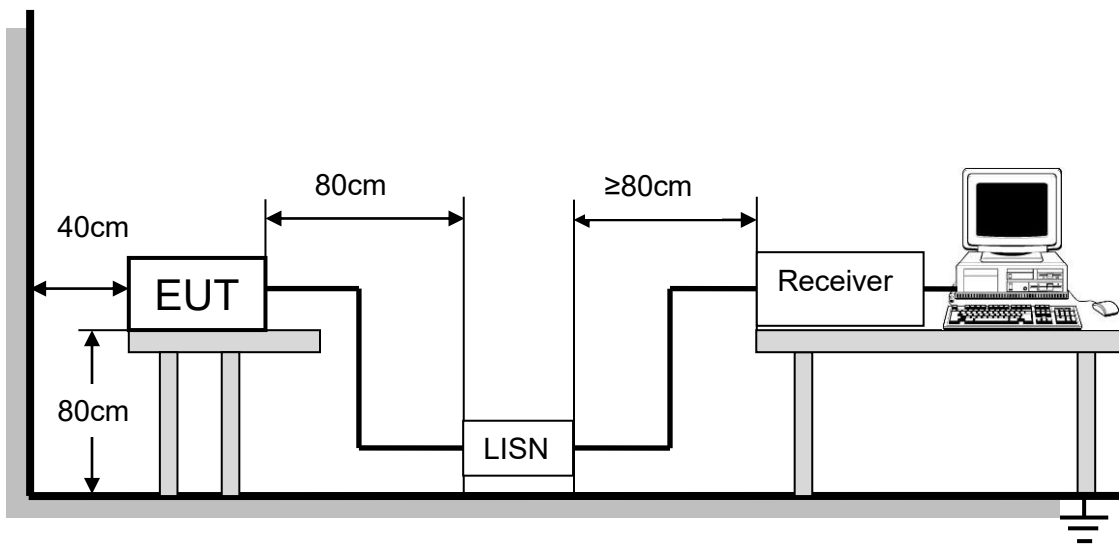

The EUT is put on a table of non-conducting material that is 80cm high. The vertical conducting wall of shielding is located 40cm to the rear of the EUT. The power line of the EUT is connected to the AC mains through a Artificial Mains Network (A.M.N.). A EMI Measurement Receiver (R&S Test Receiver ESR3) is used to test the emissions from both sides of AC line. According to the requirements in Section 6.2 of ANSI C63.10-2013. Conducted emissions from the EUT measured in the frequency range between 0.15 MHz and 30MHz using CISPR Quasi-Peak and average detector mode. The bandwidth of EMI test receiver is set at 9kHz.

The arrangement of the equipment is installed to meet the standards and operating in a manner, which tends to maximize its emission characteristics in a normal application.

TEST ENVIRONMENT

Temperature	21°C	Relative Humidity	61%
Atmosphere Pressure	101kPa	Test Voltage	AC 120V, 60HZ



TEST RESULTS

10.1. 802.11n HT20 MIMO MODE

2TX MODE (WORST-CASE CONFIGURATION)

LINE N RESULTS (MID CHANNEL)

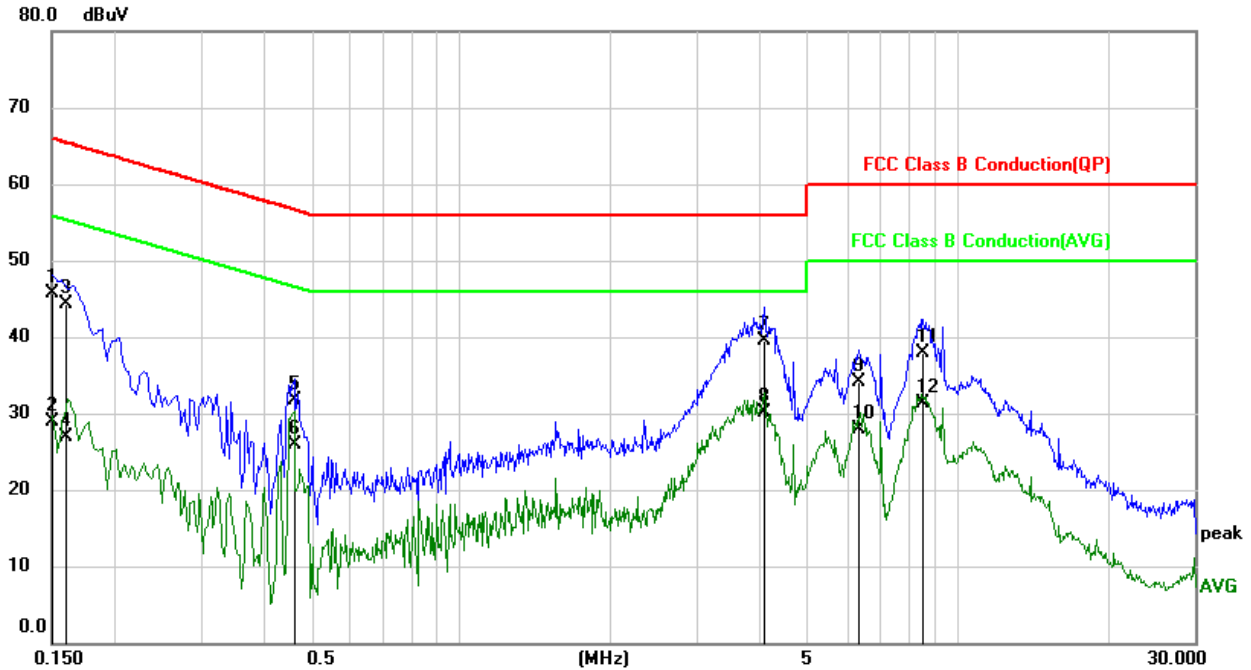

No.	Frequency (MHz)	Reading (dBuV)	Correct (dB)	Result (dBuV)	Limit (dBuV)	Margin (dB)	Remark
1	0.1510	36.18	9.60	45.78	65.94	-20.16	QP
2	0.1510	19.35	9.60	28.95	55.94	-26.99	AVG
3	0.1612	34.75	9.60	44.35	65.40	-21.05	QP
4	0.1612	17.23	9.60	26.83	55.40	-28.57	AVG
5	0.4597	22.20	9.60	31.80	56.70	-24.90	QP
6	0.4597	16.38	9.60	25.98	46.70	-20.72	AVG
7	4.0782	29.81	9.66	39.47	56.00	-16.53	QP
8	4.0782	20.47	9.66	30.13	46.00	-15.87	AVG
9	6.3555	24.46	9.71	34.17	60.00	-25.83	QP
10	6.3555	18.12	9.71	27.83	50.00	-22.17	AVG
11	8.4995	28.27	9.73	38.00	60.00	-22.00	QP
12	8.4995	21.55	9.73	31.28	50.00	-18.72	AVG

- Note: 1. Result = Reading +Correct Factor.
 2. If QP Result complies with AV limit, AV Result is deemed to comply with AV limit.
 3. Test setup: RBW: 200 Hz (9 kHz—150 kHz), 9 kHz (150 kHz—30 MHz).
 4. Step size: 80Hz (0.009MHz-0.15MHz), 4 kHz (0.15MHz-30MHz), Scan time: auto.



LINE L RESULTS (MID CHANNEL)

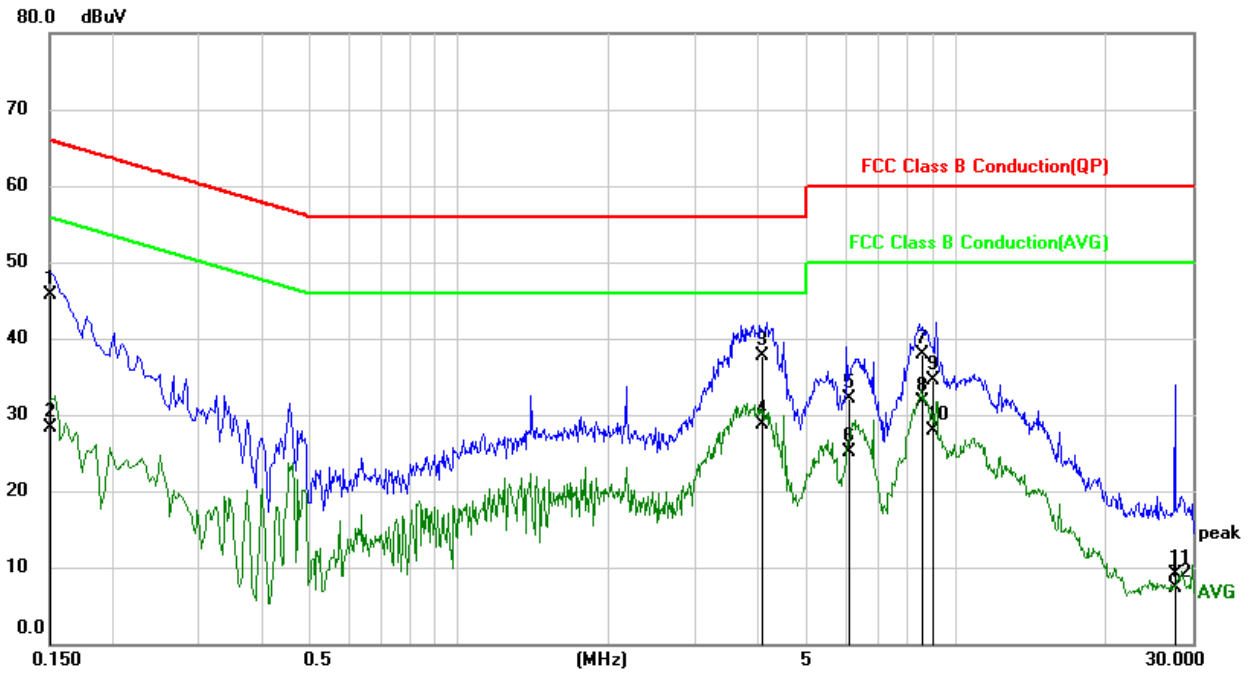

No.	Frequency (MHz)	Reading (dBuV)	Correct (dB)	Result (dBuV)	Limit (dBuV)	Margin (dB)	Remark
1	0.1507	36.12	9.61	45.73	65.96	-20.23	QP
2	0.1507	18.60	9.61	28.21	55.96	-27.75	AVG
3	4.0903	28.10	9.66	37.76	56.00	-18.24	QP
4	4.0903	19.04	9.66	28.70	46.00	-17.30	AVG
5	6.1009	22.38	9.71	32.09	60.00	-27.91	QP
6	6.1009	15.30	9.71	25.01	50.00	-24.99	AVG
7	8.5216	28.27	9.73	38.00	60.00	-22.00	QP
8	8.5216	21.92	9.73	31.65	50.00	-18.35	AVG
9	9.0834	24.81	9.73	34.54	60.00	-25.46	QP
10	9.0834	18.26	9.73	27.99	50.00	-22.01	AVG
11	27.5918	-0.71	9.87	9.16	60.00	-50.84	QP
12	27.5918	-2.55	9.87	7.32	50.00	-42.68	AVG

- Note: 1. Result = Reading +Correct Factor.
 2. If QP Result complies with AV limit, AV Result is deemed to comply with AV limit.
 3. Test setup: RBW: 200 Hz (9 kHz—150 kHz), 9 kHz (150 kHz—30 MHz).
 4. Step size: 80Hz (0.009MHz-0.15MHz), 4 kHz (0.15MHz-30MHz), Scan time: auto.

Note: All test mode has been tested, only the worst data record in the report.



11. ANTENNA REQUIREMENTS

APPLICABLE REQUIREMENTS

Please refer to FCC §15.203

An intentional radiator shall be designed to ensure that no antenna other than that furnished by the responsible party shall be used with the device. The use of a permanently attached antenna or of an antenna that uses a unique coupling to the intentional radiator shall be considered sufficient to comply with the provisions of this section. The manufacturer may design the unit so that a broken antenna can be replaced by the user, but the use of a standard antenna jack or electrical connector is prohibited.

Please refer to FCC §15.247(b)(4)

The conducted output power limit specified in paragraph (b) of this section is based on the use of antennas with directional gains that do not exceed 6 dBi. Except as shown in paragraph (c) of this section, if transmitting antennas of directional gain greater than 6 dBi are used, the conducted output power from the intentional radiator shall be reduced below the stated values in paragraphs (b)(1), (b)(2), and (b)(3) of this section, as appropriate, by the amount in dB that the directional gain of the antenna exceeds 6 dBi.

RESULTS

Complies

END OF REPORT