

# FCC Radio Test Report

## FCC ID: 2AC23-WL6E

This report concerns: Original Grant

**Project No.** : 1904C050  
**Equipment** : WIFI Module  
**Test Model** : WL6ER1510  
**Series Model** : N/A  
**Applicant** : Hui Zhou Gaoshengda Technology Co.,LTD  
**Address** : NO.75 Zhongkai Development Area, Huizhou, Guangdong

**Date of Receipt** : Apr. 11, 2019  
**Date of Test** : Apr. 12, 2019 ~ May 08, 2019  
**Issued Date** : May 10, 2019  
**Tested by** : BTL Inc.

**Testing Engineer** : Chay Cai  
 (Chay Cai)

**Technical Manager** : Steven Lu  
 (Steven Lu)

**Authorized Signatory** : Ethan Ma  
 (Ethan Ma)

# B T L I N C .

No.3, Jinshagang 1st Road, Shixia, Dalang Town, Dongguan, Guangdong, China.

TEL: +86-769-8318-3000 FAX: +86-769-8319-6000



Certificate #5123.02

### **Declaration**

**BTL** represents to the client that testing is done in accordance with standard procedures as applicable and that test instruments used has been calibrated with standards traceable to international standard(s) and/or national standard(s).

**BTL's** reports apply only to the specific samples tested under conditions. It is manufacture's responsibility to ensure that additional production units of this model are manufactured with the identical electrical and mechanical components. **BTL** shall have no liability for any declarations, inferences or generalizations drawn by the client or others from **BTL** issued reports.

The report must not be used by the client to claim product certification, approval, or endorsement by NVLAP, NIST, A2LA, or any agency of the U.S. Government.

This report is the confidential property of the client. As a mutual protection to the clients, the public and ourselves, the test report shall not be reproduced, except in full, without our written approval.

**BTL's** laboratory quality assurance procedures are in compliance with the **ISO/IEC 17025** requirements, and accredited by the conformity assessment authorities listed in this test report.

**BTL** is not responsible for the sampling stage, so the results only apply to the sample as received.

The information, data and test plan are provided by manufacturer which may affect the validity of results, so it is manufacturer's responsibility to ensure that the apparatus meets the essential requirements of applied standards and in all the possible configurations as representative of its intended use.

### **Limitation**

For the use of the authority's logo is limited unless the Test Standard(s)/Scope(s)/Item(s) mentioned in this test report is (are) included in the conformity assessment authorities acceptance respective.

Please note that the measurement uncertainty is provided for informational purpose only and are not use in determining the Pass/Fail results.

**Table of Contents****Page**

<b>REPORT ISSUED HISTORY</b>	<b>6</b>
<b>1 . GENERAL SUMMARY</b>	<b>7</b>
<b>2 . SUMMARY OF TEST RESULTS</b>	<b>8</b>
2.1 TEST FACILITY	9
2.2 MEASUREMENT UNCERTAINTY	9
<b>3 . GENERAL INFORMATION</b>	<b>10</b>
3.1 GENERAL DESCRIPTION OF EUT	10
3.2 DESCRIPTION OF TEST MODES	11
3.3 PARAMETERS OF TEST SOFTWARE	13
3.4 DUTY CYCLE	14
3.5 BLOCK DIAGRAM SHOWING THE CONFIGURATION OF SYSTEM TESTED	15
3.6 SUPPORT UNITS	15
<b>4 . AC POWER LINE CONDUCTED EMISSIONS TEST</b>	<b>16</b>
4.1 LIMIT	16
4.2 TEST PROCEDURE	16
4.3 DEVIATION FROM TEST STANDARD	16
4.4 TEST SETUP	17
4.5 EUT OPERATION CONDITIONS	17
4.6 EUT TEST CONDITIONS	17
4.7 TEST RESULTS	17
<b>5 . RADIATED EMISSIONS TEST</b>	<b>18</b>
5.1 LIMIT	18
5.2 TEST PROCEDURE	19
5.3 DEVIATION FROM TEST STANDARD	19
5.4 TEST SETUP	19
5.5 EUT OPERATION CONDITIONS	21
5.6 EUT TEST CONDITIONS	21
5.7 TEST RESULTS - 9 KHZ TO 30 MHZ	21
5.8 TEST RESULTS - 30 MHZ TO 1000 MHZ	21
5.9 TEST RESULTS - ABOVE 1000 MHZ	21
<b>6 . BANDWIDTH TEST</b>	<b>22</b>
6.1 LIMIT	22
6.2 TEST PROCEDURE	22

<b>Table of Contents</b>	<b>Page</b>
<b>6.3 DEVIATION FROM STANDARD</b>	<b>22</b>
<b>6.4 TEST SETUP</b>	<b>22</b>
<b>6.5 EUT OPERATION CONDITIONS</b>	<b>22</b>
<b>6.6 EUT TEST CONDITIONS</b>	<b>22</b>
<b>6.7 TEST RESULTS</b>	<b>22</b>
<b>7 . MAXIMUM OUTPUT POWER TEST</b>	<b>23</b>
<b>7.1 LIMIT</b>	<b>23</b>
<b>7.2 TEST PROCEDURE</b>	<b>23</b>
<b>7.3 DEVIATION FROM STANDARD</b>	<b>23</b>
<b>7.4 TEST SETUP</b>	<b>23</b>
<b>7.5 EUT OPERATION CONDITIONS</b>	<b>23</b>
<b>7.6 EUT TEST CONDITIONS</b>	<b>23</b>
<b>7.7 TEST RESULTS</b>	<b>23</b>
<b>8 . CONDUCTED SPURIOUS EMISSIONS</b>	<b>24</b>
<b>8.1 LIMIT</b>	<b>24</b>
<b>8.2 TEST PROCEDURE</b>	<b>24</b>
<b>8.3 DEVIATION FROM STANDARD</b>	<b>24</b>
<b>8.4 TEST SETUP</b>	<b>24</b>
<b>8.5 EUT OPERATION CONDITIONS</b>	<b>24</b>
<b>8.6 EUT TEST CONDITIONS</b>	<b>24</b>
<b>8.7 TEST RESULTS</b>	<b>24</b>
<b>9 . POWER SPECTRAL DENSITY TEST</b>	<b>25</b>
<b>9.1 LIMIT</b>	<b>25</b>
<b>9.2 TEST PROCEDURE</b>	<b>25</b>
<b>9.3 DEVIATION FROM STANDARD</b>	<b>25</b>
<b>9.4 TEST SETUP</b>	<b>25</b>
<b>9.5 EUT OPERATION CONDITIONS</b>	<b>25</b>
<b>9.6 EUT TEST CONDITIONS</b>	<b>25</b>
<b>9.7 TEST RESULTS</b>	<b>25</b>
<b>10 . MEASUREMENT INSTRUMENTS LIST</b>	<b>26</b>
<b>11 . EUT TEST PHOTO</b>	<b>28</b>
<b>APPENDIX A - AC POWER LINE CONDUCTED EMISSIONS</b>	<b>33</b>
<b>APPENDIX B - RADIATED EMISSION - 9 KHZ TO 30 MHZ</b>	<b>36</b>

**Table of Contents****Page**

<b>APPENDIX C - RADIATED EMISSION - 30 MHZ TO 1000 MHZ</b>	<b>41</b>
<b>APPENDIX D - RADIATED EMISSION- ABOVE 1000 MHZ</b>	<b>44</b>
<b>APPENDIX E - BANDWIDTH</b>	<b>93</b>
<b>APPENDIX F - MAXIMUM OUTPUT POWER</b>	<b>96</b>
<b>APPENDIX G - CONDUCTED SPURIOUS EMISSIONS</b>	<b>98</b>
<b>APPENDIX H - POWER SPECTRAL DENSITY</b>	<b>103</b>

### REPORT ISSUED HISTORY

Report Version	Description	Issued Date
R00	Original Issue.	May 10, 2019

## 1. GENERAL SUMMARY

Equipment : WIFI Module  
Brand Name : GSD  
Test Model : WL6ER1510  
Series Model : N/A  
Applicant : Hui Zhou Gaoshengda Technology Co.,LTD  
Manufacturer : Hui Zhou Gaoshengda Technology Co.,LTD  
Address : NO.75 Zhongkai Development Area,Huizhou,Guangdong  
Factory : Hui Zhou Gaoshengda Technology Co.,LTD  
Address : NO.75 Zhongkai Development Area,Huizhou,Guangdong  
Date of Test : Apr. 12, 2019 ~ May 08, 2019  
Test Sample : Engineering Sample No.: D190403745 for conducted, D190404553 for radiated.  
Standard(s) : FCC Part15, Subpart C (15.247)  
ANSI C63.10-2013  
KDB 558074 D01 15.247 Meas Guidance

The above equipment has been tested and found compliance with the requirement of the relative standards by BTL Inc.

The test data, data evaluation, and equipment configuration contained in our test report (Ref No. BTL-FCCP-1-1904C050) were obtained utilizing the test procedures, test instruments, test sites that has been accredited by the Authority of A2LA according to the ISO/IEC 17025 quality assessment standard and technical standard(s).

**Test results included in this report are only for the WLAN 2.4 GHz part.**

## 2. SUMMARY OF TEST RESULTS

Test procedures according to the technical standard(s):

Applied Standard(s): FCC Part15, Subpart C (15.247)				
Standard(s) Section	Test Item	Test Result	Judgment	Remark
15.207	AC Power Line Conducted Emissions	APPENDIX A	PASS	-----
15.247(d) 15.205(a) 15.209(a)	Radiated Emissions	APPENDIX B APPENDIX C APPENDIX D	PASS	-----
15.247(a)(2)	Bandwidth	APPENDIX E	PASS	-----
15.247(b)(3)	Maximum Output Power	APPENDIX F	PASS	-----
15.247(d)	Conducted Spurious Emissions	APPENDIX G	PASS	-----
15.247(e)	Power Spectral Density	APPENDIX H	PASS	-----
15.203	Antenna Requirement	-----	PASS	-----

Note:

(1) "N/A" denotes test is not applicable in this test report.



## 2.1 TEST FACILITY

The test facilities used to collect the test data in this report is at the location of No.3, Jinshagang 1st Road, Shixia, Dalang Town, Dongguan, Guangdong, China.

BTL's Test Firm Registration Number for FCC: 357015

BTL's Designation Number for FCC: CN1240

## 2.2 MEASUREMENT UNCERTAINTY

ISO/IEC 17025 requires that an estimate of the measurement uncertainties associated with the emissions test results be included in the report. The measurement uncertainties given below are based on a 95% confidence level (based on a coverage factor (k=2))

The BTL measurement uncertainty as below table:

### A. AC power line conducted emissions test:

Test Site	Method	Measurement Frequency Range	U, (dB)
DG-C02	CISPR	150 kHz ~ 30 MHz	2.32

### B. Radiated emissions test:

Test Site	Method	Measurement Frequency Range	Ant. H / V	U, (dB)
DG-CB03	CISPR	9 KHz~30 MHz	V	3.79
		9 KHz~30 MHz	H	3.57
		30 MHz~200 MHz	V	3.82
		30 MHz~200 MHz	H	3.78
		200 MHz~1,000 MHz	V	4.10
		200 MHz~1,000 MHz	H	4.06
		1 GHz~18 GHz	V	3.12
		1 GHz~18 GHz	H	3.68
		18 GHz~40 GHz	V	4.15
		18 GHz~40 GHz	H	4.14

Note: Unless specifically mentioned, the uncertainty of measurement has not been taken into account to declare the compliance or non-compliance to the specification.

### 3. GENERAL INFORMATION

#### 3.1 GENERAL DESCRIPTION OF EUT

Equipment	WIFI Module
Brand Name	GSD
Test Model	WL6ER1510
Series Model	N/A
Model Difference(s)	N/A
Software Version	V1.0
Hardware Version	V1.0
Power Source	DC voltage supplied from external power supply.
Power Rating	DC 5V
Operation Frequency	2412 MHz ~ 2462 MHz
Modulation Type	IEEE 802.11b: DSSS IEEE 802.11g: OFDM IEEE 802.11n: OFDM
Bit Rate of Transmitter	IEEE 802.11b: 11/5.5/2/1 Mbps IEEE 802.11g: 54/48/36/24/18/12/9/6 Mbps IEEE 802.11n: up to 150 Mbps
Maximum Output Power	IEEE 802.11b: 16.02 dBm (0.0400 W) IEEE 802.11g: 14.43 dBm (0.0277 W) IEEE 802.11n (HT20): 12.48 dBm (0.0177 W) IEEE 802.11n (HT40): 12.53 dBm (0.0179 W)

Note:

1. For a more detailed features description, please refer to the manufacturer's specifications or the user's manual.

2. Channel List:

CH01 - CH11 for 802.11b, 802.11g, 802.11n(20 MHz)							
CH03 - CH09 for 802.11n(40 MHz)							
Channel	Frequency (MHz)	Channel	Frequency (MHz)	Channel	Frequency (MHz)	Channel	Frequency (MHz)
01	2412	04	2427	07	2442	10	2457
02	2417	05	2432	08	2447	11	2462
03	2422	06	2437	09	2452		

3. Antenna Specification:

Ant.	Brand	Model Name	Antenna Type	Connector	Gain (dBi)
1	N/A	N/A	PCB	N/A	2.50

### 3.2 DESCRIPTION OF TEST MODES

The test system was pre-tested based on the consideration of all possible combinations of EUT operation mode.

Pretest Mode	Description
Mode 1	TX B Mode Channel 01/06/11
Mode 2	TX G Mode Channel 01/06/11
Mode 3	TX N-20 MHz Mode Channel 01/06/11
Mode 4	TX N-40 MHz Mode Channel 03/06/09
Mode 5	TX B Mode Channel 11

Following mode(s) as (were) found to be the worst case(s) and selected for the final test.

<b>AC power line conducted emissions test</b>	
Final Test Mode:	Description
Mode 5	TX B Mode Channel 11

<b>Radiated emissions test</b>	
Final Test Mode:	Description
Mode 1	TX B Mode Channel 01/06/11
Mode 2	TX G Mode Channel 01/06/11
Mode 3	TX N-20 MHz Mode Channel 01/06/11
Mode 4	TX N-40 MHz Mode Channel 03/06/09

<b>Conducted test</b>	
Final Test Mode:	Description
Mode 1	TX B Mode Channel 01/06/11
Mode 2	TX G Mode Channel 01/06/11
Mode 3	TX N-20 MHz Mode Channel 01/06/11
Mode 4	TX N-40 MHz Mode Channel 03/06/09

NOTE:

- (1) The measurements are performed at the high, middle, low available channels.
- (2) 802.11b mode: CCK (1 Mbps)  
802.11g mode: BPSK (6 Mbps)  
802.11n HT20 mode : BPSK (6.5 Mbps)  
802.11n HT40 mode : BPSK (13.5 Mbps)  
For radiated emission tests, the highest output powers were set for final test.
- (3) For radiated emission below 1 GHz test, the IEEE 802.11b channel 11 is found to be the worst case and recorded.
- (4) For radiated emission above 1 GHz test, 1GHz~26.5GHz have been pre-tested and in this report only recorded the worst case. The remaining spurious points are all below the limit value of 20dB.

### 3.3 PARAMETERS OF TEST SOFTWARE

Test Software	UI_mptool v1.0.0.1		
Frequency (MHz)	2412	2437	2462
IEEE 802.11b	33	32	33
IEEE 802.11g	38	38	38
IEEE 802.11n (HT20)	34	34	34
Frequency (MHz)	2422	2437	2452
IEEE 802.11n (HT40)	34	34	34

### 3.4 DUTY CYCLE

If duty cycle is  $\geq 98\%$ , duty factor is not required.  
 If duty cycle is  $< 98\%$ , duty factor shall be considered.  
 The output power = measured power + duty factor.

**IEEE 802.11b**

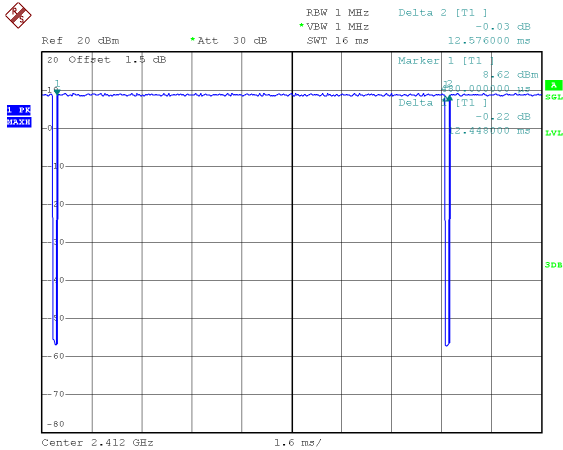

Date: 7.MAY.2019 20:10:30

Duty cycle =  $12.448 \text{ ms} / 12.576 \text{ ms} = 98.98\%$   
 Duty Factor =  $10 \log(1/\text{Duty cycle}) = 0.00$

**IEEE 802.11n (HT20)**

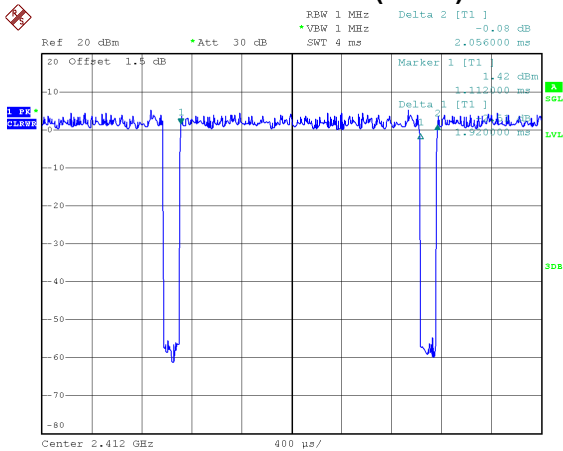

Date: 7.MAY.2019 20:11:52

Duty cycle =  $1.920 \text{ ms} / 2.056 \text{ ms} = 93.39\%$   
 Duty Factor =  $10 \log(1/\text{Duty cycle}) = 0.30$

**IEEE 802.11g**

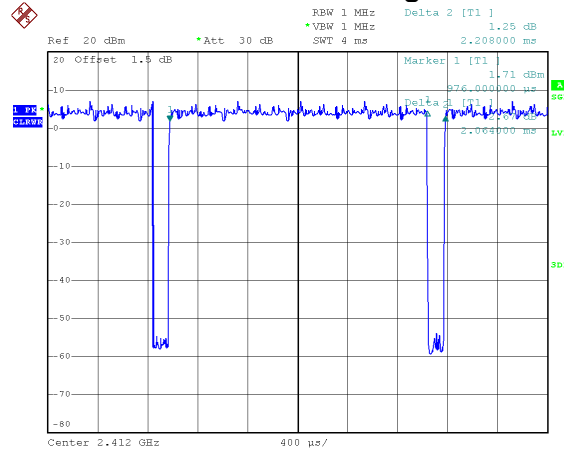

Date: 7.MAY.2019 20:11:20

Duty cycle =  $2.064 \text{ ms} / 2.208 \text{ ms} = 93.48\%$   
 Duty Factor =  $10 \log(1/\text{Duty cycle}) = 0.29$

**IEEE 802.11n (HT40)**

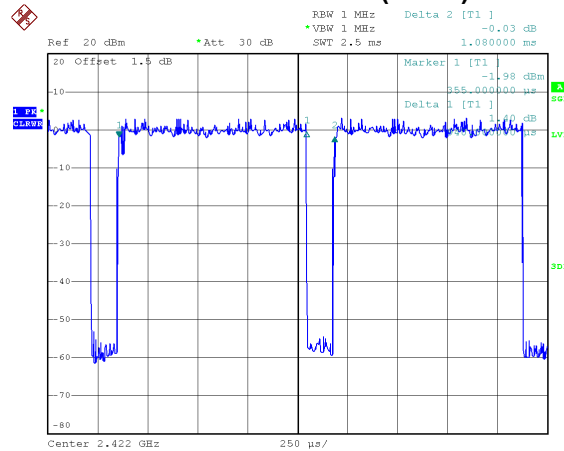

Date: 7.MAY.2019 20:12:15

Duty cycle =  $0.940 \text{ ms} / 1.080 \text{ ms} = 87.04\%$   
 Duty Factor =  $10 \log(1/\text{Duty cycle}) = 0.60$

**NOTE:**

For IEEE 802.11g and IEEE 802.11n (HT20):  
 For radiated emissions frequency above 1 GHz, the resolution bandwidth of test receiver/spectrum analyzer is 1 MHz and the video bandwidth is 1 kHz (Duty cycle  $< 98\%$ ).

For IEEE 802.11n (HT40):  
 For radiated emissions frequency above 1 GHz, the resolution bandwidth of test receiver/spectrum analyzer is 1 MHz and the video bandwidth is 2 kHz (Duty cycle  $< 98\%$ ).

**3.5 BLOCK DIAGRAM SHOWING THE CONFIGURATION OF SYSTEM TESTED**

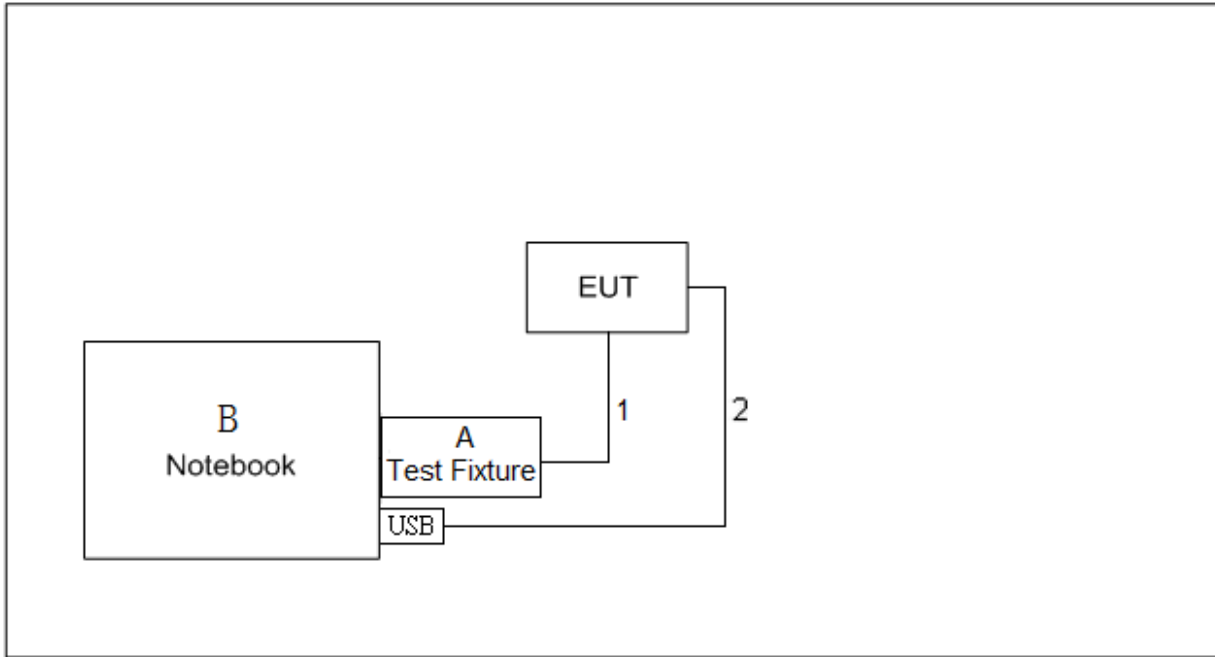

**3.6 SUPPORT UNITS**

Item	Equipment	Mfr/Brand	Model/Type No.	Series No.
A	Test Fixture	N/A	N/A	N/A
B	Notebook	Lenovo	V310-14ISK	LR07GZNB

Item	Shielded Type	Ferrite Core	Length	Note
1	NO	NO	0.2m	Data Cable
2	NO	NO	0.3m	DC Cable

## 4. AC POWER LINE CONDUCTED EMISSIONS TEST

### 4.1 LIMIT

Frequency of Emission (MHz)	Limit (dB $\mu$ V)	
	Quasi-peak	Average
0.15 - 0.50	66 to 56*	56 to 46*
0.50 - 5.0	56	46
5.0 - 30.0	60	50

NOTE:

- (1) The tighter limit applies at the band edges.
- (2) The limit of " \* " marked band means the limitation decreases linearly with the logarithm of the frequency in the range.

The following table is the setting of the receiver

Receiver Parameters	Setting
Attenuation	10 dB
Start Frequency	0.15 MHz
Stop Frequency	30 MHz
IF Bandwidth	9 kHz

### 4.2 TEST PROCEDURE

- a. The EUT was placed 0.8 meters from the horizontal ground plane with EUT being connected to the power mains through a line impedance stabilization network (LISN). All other support equipment powered from additional LISN(s). The LISN provide 50 Ohm/ 50uH of coupling impedance for the measuring instrument.
- b. Interconnecting cables that hang closer than 40 cm to the ground plane shall be folded back and forth in the center forming a bundle 30 to 40 cm long.
- c. I/O cables that are not connected to a peripheral shall be bundled in the center. The end of the cable may be terminated, if required, using the correct terminating impedance. The overall length shall not exceed 1 m.
- d. LISN at least 80 cm from nearest part of EUT chassis.
- e. For the actual test configuration, please refer to the related Item -EUT Test Photos.

### 4.3 DEVIATION FROM TEST STANDARD

No deviation



**4.4 TEST SETUP**

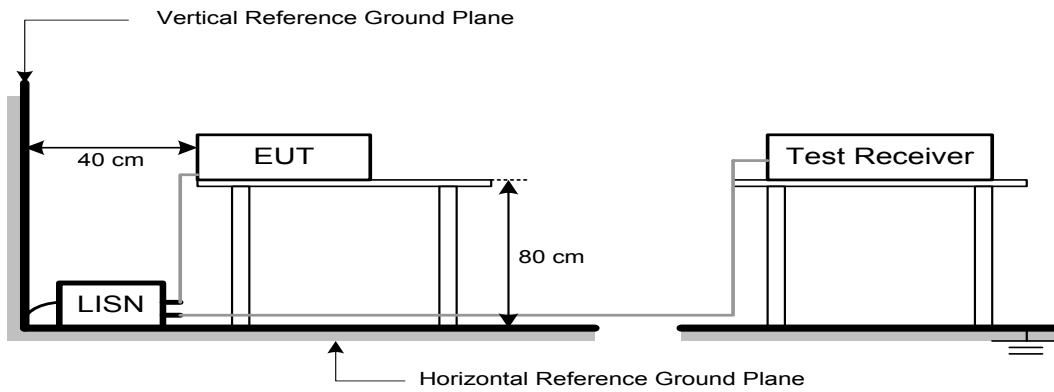

**4.5 EUT OPERATION CONDITIONS**

EUT was programmed to be in continuously transmitting mode.

**4.6 EUT TEST CONDITIONS**

Temperature: 25°C    Relative Humidity: 53%    Test Voltage: AC 120V/60Hz

**4.7 TEST RESULTS**

Please refer to the APPENDIX A.

## 5. RADIATED EMISSIONS TEST

### 5.1 LIMIT

In case the emission fall within the restricted band specified on 15.205(a), then the 15.209(a) limit in the table below has to be followed.

#### LIMITS OF RADIATED EMISSION MEASUREMENT (9 kHz-1000 MHz)

Frequency (MHz)	Field Strength (microvolts/meter)	Measurement Distance (meters)
0.009-0.490	2400/F(kHz)	300
0.490-1.705	24000/F(kHz)	30
1.705-30.0	30	30
30-88	100	3
88-216	150	3
216-960	200	3
Above 960	500	3

#### LIMITS OF RADIATED EMISSION MEASUREMENT (Above 1000 MHz)

Frequency (MHz)	(dBuV/m at 3 m)	
	Peak	Average
Above 1000	74	54

#### NOTE:

- (1) The limit for radiated test was performed according to FCC PART 15C.
- (2) The tighter limit applies at the band edges.
- (3) Emission level (dBuV/m)=20log Emission level (uV/m).

Spectrum Parameter	Setting
Attenuation	Auto
Start Frequency	1000 MHz
Stop Frequency	10th carrier harmonic
RBW / VBW (Emission in restricted band)	1 MHz / 3 MHz for Peak, 1 MHz / 1/T for Average

Receiver Parameter	Setting
Attenuation	Auto
Start ~ Stop Frequency	9 kHz~90 kHz for PK/AVG detector
Start ~ Stop Frequency	90 kHz~110 kHz for QP detector
Start ~ Stop Frequency	110 kHz~490 kHz for PK/AVG detector
Start ~ Stop Frequency	490 kHz~30 MHz for QP detector
Start ~ Stop Frequency	30 MHz~1000 MHz for QP detector

**5.2 TEST PROCEDURE**

- a. The measuring distance of 3 m shall be used for measurements. The EUT was placed on the top of a rotating table 0.8 meter above the ground at a 3 meter semi-anechoic chamber. The table was rotated 360 degrees to determine the position of the highest radiation.(below 1 GHz)
- b. The measuring distance of 3 m shall be used for measurements. The EUT was placed on the top of a rotating table 1.5 meter above the ground at a 3 meter semi-anechoic chamber. The table was rotated 360 degrees to determine the position of the highest radiation.(above 1 GHz)
- c. The height of the equipment or of the substitution antenna shall be 0.8m or 1.5m; the height of the test antenna shall vary between 1 m to 4 m. Both horizontal and vertical polarizations of the antenna are set to make the measurement.
- d. For each suspected emission, the EUT was arranged to its worst case and then the antenna was tuned to heights find the maximum reading (used Bore sight function).
- e. The receiver system was set to peak and average detect function and specified bandwidth with maximum hold mode when the test frequency is above 1 GHz.
- f. The initial step in collecting radiated emission data is a receiver peak detector mode pre-scanning the measurement frequency range. Significant peaks are then marked and then Quasi Peak detector mode re-measured.
- g. All readings are Peak unless otherwise stated QP in column of Note. Peak denotes that the Peak reading compliance with the QP Limits and then QP Mode measurement didn't perform. (below 1 GHz)
- h. All readings are Peak Mode value unless otherwise stated AVG in column of Note. If the Peak Mode Measured value compliance with the Peak Limits and lower than AVG Limits, the EUT shall be deemed to meet both Peak & AVG Limits and then only Peak Mode was measured, but AVG Mode didn't perform. (above 1 GHz)
- i. For the actual test configuration, please refer to the related Item -EUT Test Photos.

**5.3 DEVIATION FROM TEST STANDARD**

No deviation

**5.4 TEST SETUP**

**9 kHz-30 MHz**

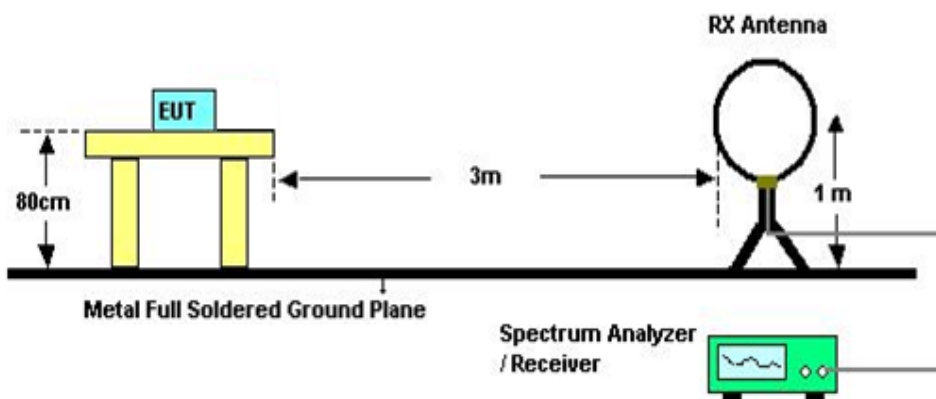

30 MHz to 1 GHz

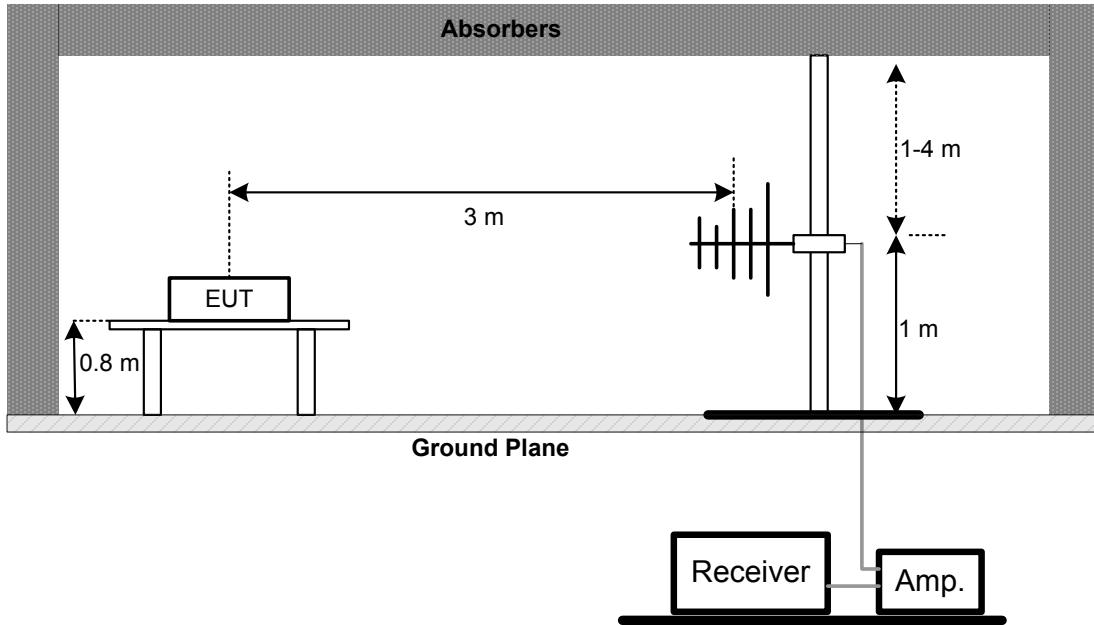

Above 1 GHz

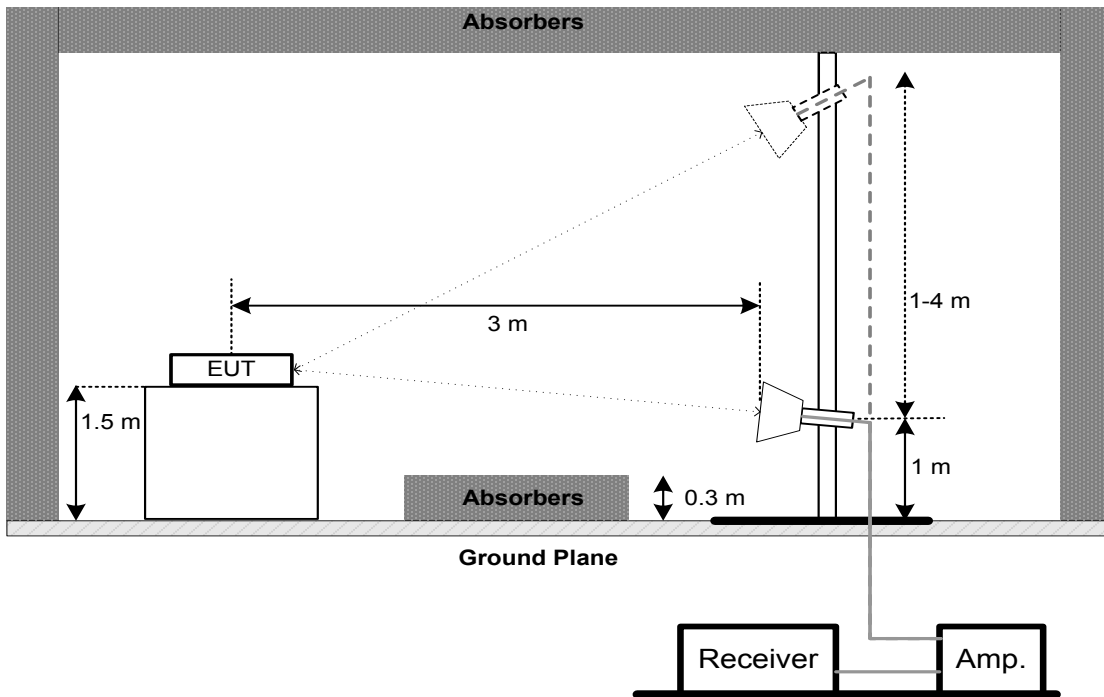

### 5.5 EUT OPERATION CONDITIONS

The EUT was programmed to be in continuously transmitting mode.

### 5.6 EUT TEST CONDITIONS

Temperature: 24°C    Relative Humidity: 68%    Test Voltage: DC 5V

### 5.7 TEST RESULTS - 9 KHZ TO 30 MHZ

Please refer to the APPENDIX B

Remark:

- (1) Distance extrapolation factor =  $40 \log (\text{specific distance} / \text{test distance})$  (dB).
- (2) Limit line = specific limits (dBuV) + distance extrapolation factor.

### 5.8 TEST RESULTS - 30 MHZ TO 1000 MHZ

Please refer to the APPENDIX C.

### 5.9 TEST RESULTS - ABOVE 1000 MHZ

Please refer to the APPENDIX D.

Remark:

- (1) No limit: This is fundamental signal, the judgment is not applicable.  
For fundamental signal judgment was referred to Peak output test.

## 6. BANDWIDTH TEST

### 6.1 LIMIT

FCC Part15, Subpart C (15.247)		
Section	Test Item	Limit
15.247(a)(2)	6 dB Bandwidth	Minimum 500 kHz
	99% Emission Bandwidth	-

### 6.2 TEST PROCEDURE

- The EUT was directly connected to the spectrum analyzer and antenna output port as show in the block diagram below.
- Spectrum Setting: RBW= 100 kHz, VBW=300 kHz, Sweep time = 2.5 ms.
- The bandwidth was performed in accordance with method 11.8 of ANSI C63.10-2013.

### 6.3 DEVIATION FROM STANDARD

No deviation.

### 6.4 TEST SETUP

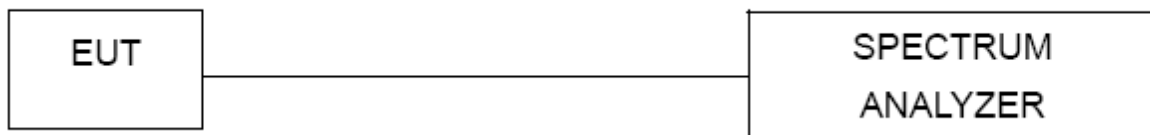

### 6.5 EUT OPERATION CONDITIONS

The EUT was programmed to be in continuously transmitting mode.

### 6.6 EUT TEST CONDITIONS

Temperature: 24°C    Relative Humidity: 65%    Test Voltage: DC 5V

### 6.7 TEST RESULTS

Please refer to the APPENDIX E.

**7. MAXIMUM OUTPUT POWER TEST**

**7.1 LIMIT**

FCC Part15, Subpart C (15.247)		
Section	Test Item	Limit
15.247(b)(3)	Maximum Output Power	1 Watt or 30dBm

**7.2 TEST PROCEDURE**

- a. The EUT was directly connected to the power meter and antenna output port as show in the block diagram below.
- b. The maximum conducted output power was performed in accordance with method 11.9.1.3 of ANSI C63.10-2013.

**7.3 DEVIATION FROM STANDARD**

No deviation.

**7.4 TEST SETUP**



**7.5 EUT OPERATION CONDITIONS**

The EUT was programmed to be in continuously transmitting mode.

**7.6 EUT TEST CONDITIONS**

Temperature: 24°C    Relative Humidity: 65%    Test Voltage: DC 5V

**7.7 TEST RESULTS**

Please refer to the APPENDIX F.

**8. CONDUCTED SPURIOUS EMISSIONS**

**8.1 LIMIT**

In any 100 kHz bandwidth outside the frequency band in which the spread spectrum or digitally modulated intentional radiator is operating, the radio frequency power that is produced by the intentional radiator shall be at least 20 dB below that in the 100 kHz bandwidth within the band that contains the highest level of the desired power, based on either an RF conducted or a radiated measurement, provided the transmitter demonstrates compliance with the peak Output Power limits. If the transmitter complies with the Output Power limits based on the use of RMS averaging over a time interval, as permitted under paragraph (b)(3) of this section, the attenuation required under this paragraph shall be 30 dB instead of 20 dB. Attenuation below the general limits specified in Section 15.209(a) is not required. In addition, radiated emissions which fall in the restricted bands, as defined in Section 15.205(a), must also comply with the radiated emission limits specified in Section 15.209(a) (see Section 15.205(c)).

**8.2 TEST PROCEDURE**

- a. The EUT was directly connected to the spectrum analyzer and antenna output port as show in the block diagram below.
- b. Spectrum Setting: RBW= 100 kHz, VBW=300 kHz, Sweep time = Auto.

**8.3 DEVIATION FROM STANDARD**

No deviation.

**8.4 TEST SETUP**

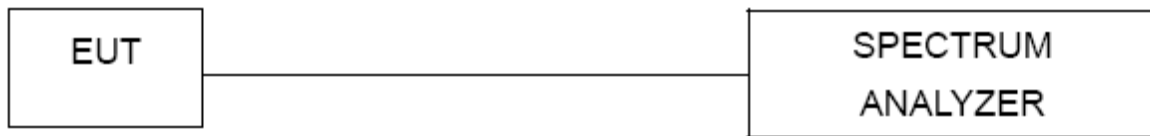

**8.5 EUT OPERATION CONDITIONS**

The EUT was programmed to be in continuously transmitting mode.

**8.6 EUT TEST CONDITIONS**

Temperature: 24°C    Relative Humidity: 65%    Test Voltage: DC 5V

**8.7 TEST RESULTS**

Please refer to the APPENDIX G.



## 9. POWER SPECTRAL DENSITY TEST

### 9.1 LIMIT

FCC Part15, Subpart C (15.247)		
Section	Test Item	Limit
15.247(e)	Power Spectral Density	8 dBm (in any 3 kHz)

### 9.2 TEST PROCEDURE

- a. The EUT was directly connected to the spectrum analyzer and antenna output port as show in the block diagram below.
- b. Spectrum Setting: RBW=3 kHz, VBW=10 kHz, Sweep time = Auto.
- c. The Power Spectral Density was performed in accordance with method 11.10.2 of ANSI C63.10-2013.

### 9.3 DEVIATION FROM STANDARD

No deviation.

### 9.4 TEST SETUP

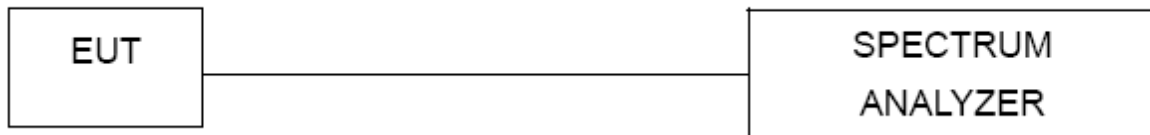

### 9.5 EUT OPERATION CONDITIONS

The EUT was programmed to be in continuously transmitting mode.

### 9.6 EUT TEST CONDITIONS

Temperature: 24°C    Relative Humidity: 65%    Test Voltage: DC 5V

### 9.7 TEST RESULTS

Please refer to the APPENDIX H.

## 10. MEASUREMENT INSTRUMENTS LIST

AC Power Line Conducted Emissions					
Item	Kind of Equipment	Manufacturer	Type No.	Serial No.	Calibrated until
1	EMI Test Receiver	R&S	ESCI	100382	Mar. 10, 2020
2	LISN	EMCO	3816/2	52765	Mar. 10, 2020
3	50ohm Terminator	SHX	TF5-3	15041305	Mar. 10, 2020
4	Artificial-Mains Network	SCHWARZBECK	NSLK 8127	8127685	Mar. 10, 2020
5	TRANSIENT LIMITER	EM	EM-7600	772	Mar. 10, 2020
6	Measurement Software	Farad	EZ-EMC Ver.NB-03A1-01	N/A	N/A
7	Cable	N/A	RG223	12m	Mar. 12, 2020

Radiated Emissions - 9 kHz to 30 MHz					
Item	Kind of Equipment	Manufacturer	Type No.	Serial No.	Calibrated until
1	Loop Antenna	EM	EM-6876-1	230	Jan. 15, 2020
2	Cable	N/A	RG 213/U	C-102	Jun. 01, 2019
3	EMI Test Receiver	R&S	ESCI	100895	Mar. 10, 2020
4	Measurement Software	Farad	EZ-EMC Ver.NB-03A1-01	N/A	N/A

Radiated Emissions - 30 MHz to 1 GHz					
Item	Kind of Equipment	Manufacturer	Type No.	Serial No.	Calibrated until
1	Antenna	Schwarzbeck	VULB9160	9160-3232	Mar. 09, 2020
2	Amplifier	HP	8447D	2944A09673	Aug. 11, 2019
3	Receiver	Agilent	N9038A	MY52130039	Aug. 11, 2019
4	Cable	emci	LMR-400(30MHz-1GHz)(8m+5m)	N/A	May 25, 2019
5	Controller	CT	SC100	N/A	N/A
6	Controller	MF	MF-7802	MF780208416	N/A
7	Measurement Software	Farad	EZ-EMC Ver.NB-03A1-01	N/A	N/A

Radiated Emissions - Above 1 GHz					
Item	Kind of Equipment	Manufacturer	Type No.	Serial No.	Calibrated until
1	Double Ridged Guide Antenna	ETS	3115	75789	Mar. 09, 2020
2	Broad-Band Horn Antenna	Schwarzbeck	BBHA 9170	9170319	Jun. 30, 2019
3	Amplifier	Agilent	8449B	3008A02333	Mar. 10, 2020
4	Microwave Preamplifier With Adaptor	EMC INSTRUMENT	EMC2654045	980039 & HA01	Mar. 10, 2020
5	Receiver	Agilent	N9038A	MY52130039	Aug. 11, 2019
6	Controller	CT	SC100	N/A	N/A
7	Controller	MF	MF-7802	MF780208416	N/A
8	Cable	mitron	B10-01-01-12M	18072744	Jul. 30, 2019
9	Measurement Software	Farad	EZ-EMC Ver.NB-03A1-01	N/A	N/A

Bandwidth					
Item	Kind of Equipment	Manufacturer	Type No.	Serial No.	Calibrated until
1	Spectrum Analyzer	R&S	FSP40	100185	Aug. 11, 2019

Maximum Output Power					
Item	Kind of Equipment	Manufacturer	Type No.	Serial No.	Calibrated until
1	P-series power meter	Agilent	N1911A	MY45100473	Aug. 11, 2019
2	wideband power sensor	Agilent	N1921A	MY51100041	Aug. 11, 2019

Antenna Conducted Spurious Emissions					
Item	Kind of Equipment	Manufacturer	Type No.	Serial No.	Calibrated until
1	Spectrum Analyzer	R&S	FSP40	100185	Aug. 11, 2019

Power Spectral Density					
Item	Kind of Equipment	Manufacturer	Type No.	Serial No.	Calibrated until
1	Spectrum Analyzer	R&S	FSP40	100185	Aug. 11, 2019

Remark: "N/A" denotes no model name, serial no. or calibration specified.  
 All calibration period of equipment list is one year.

**11. EUT TEST PHOTO****AC Power Line Conducted Emissions Test Photos**

### Radiated Emissions Test Photos

9 kHz to 30 MHz



### Radiated Emissions Test Photos

30 MHz to 1 GHz

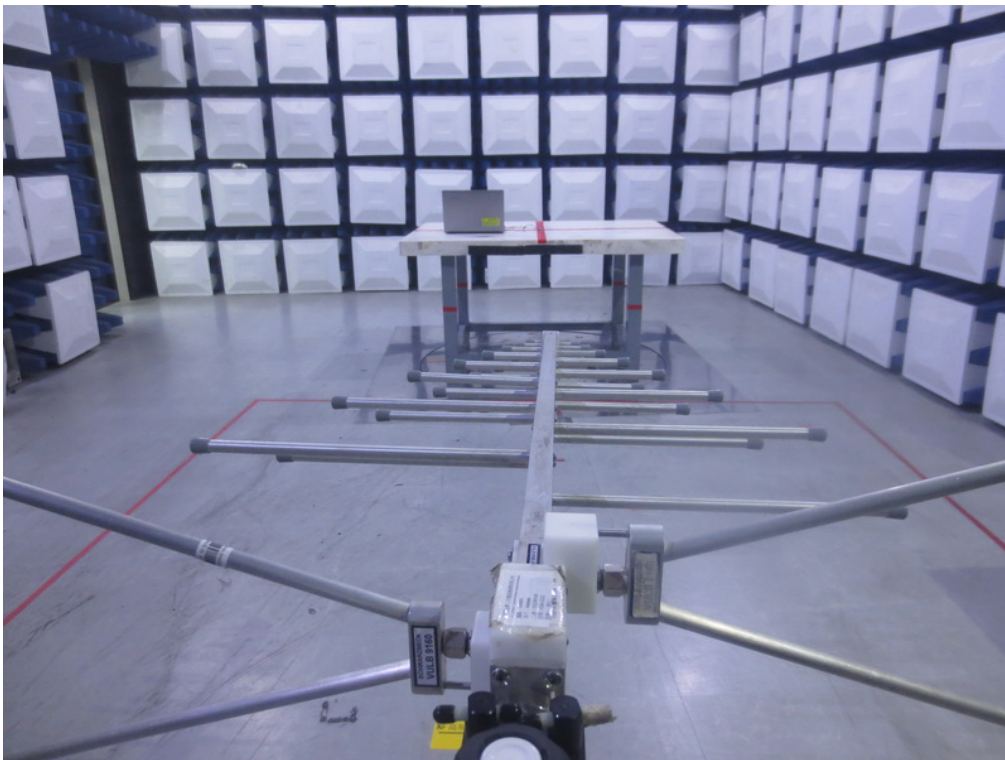
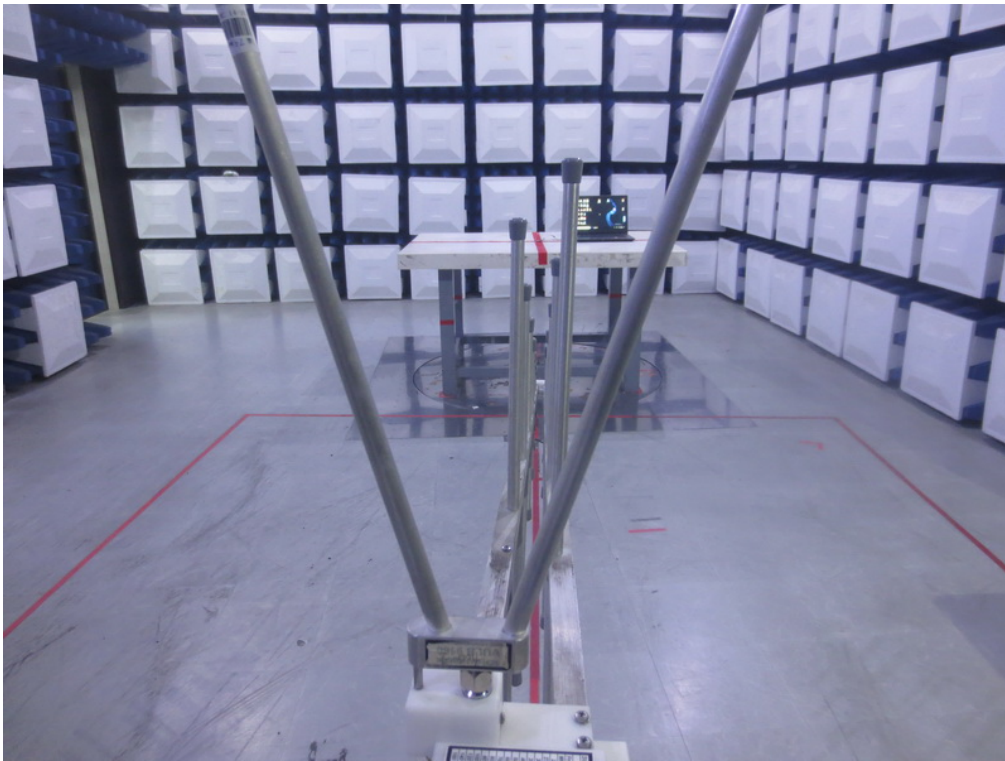

**Radiated Emissions Test Photos**  
**Above 1 GHz**

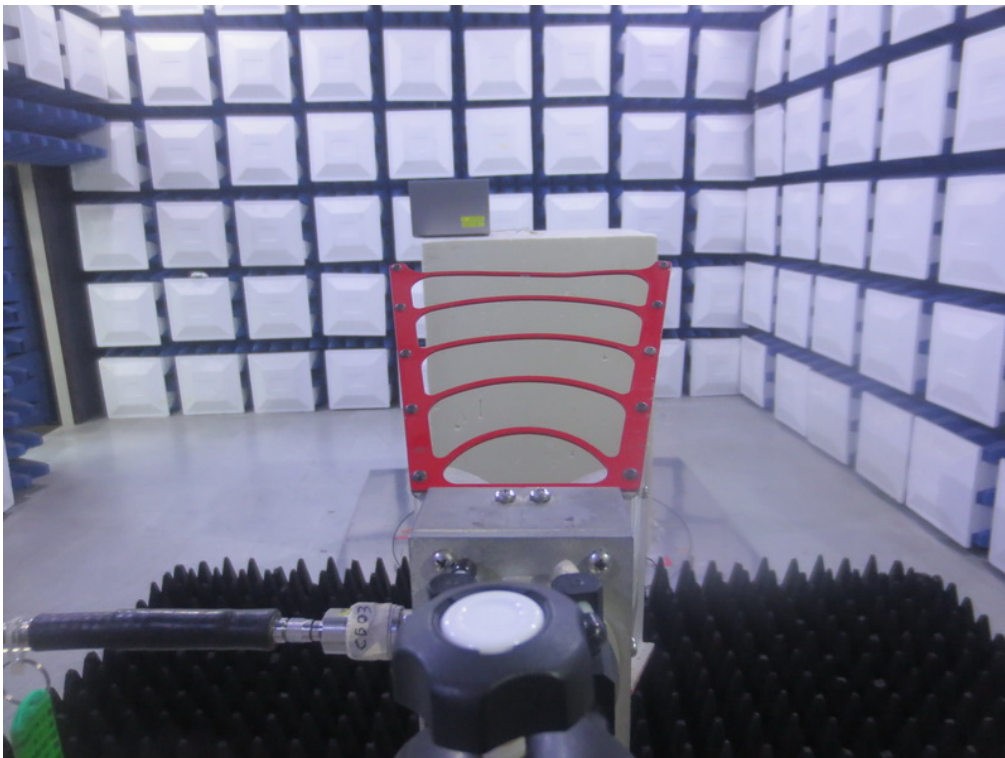
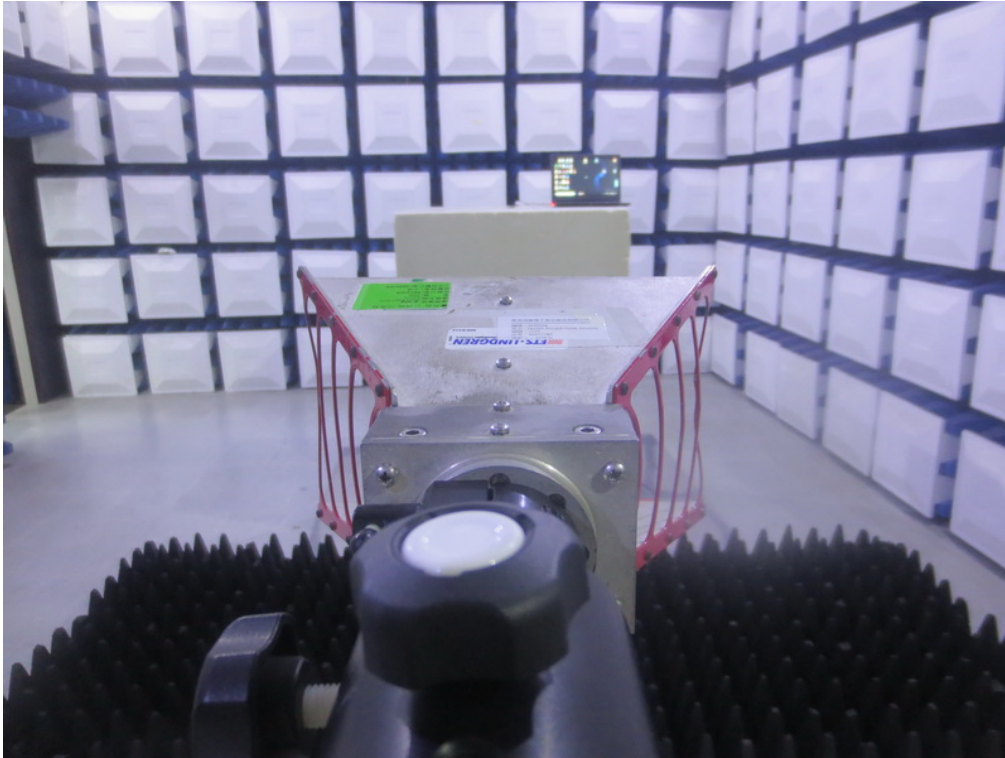

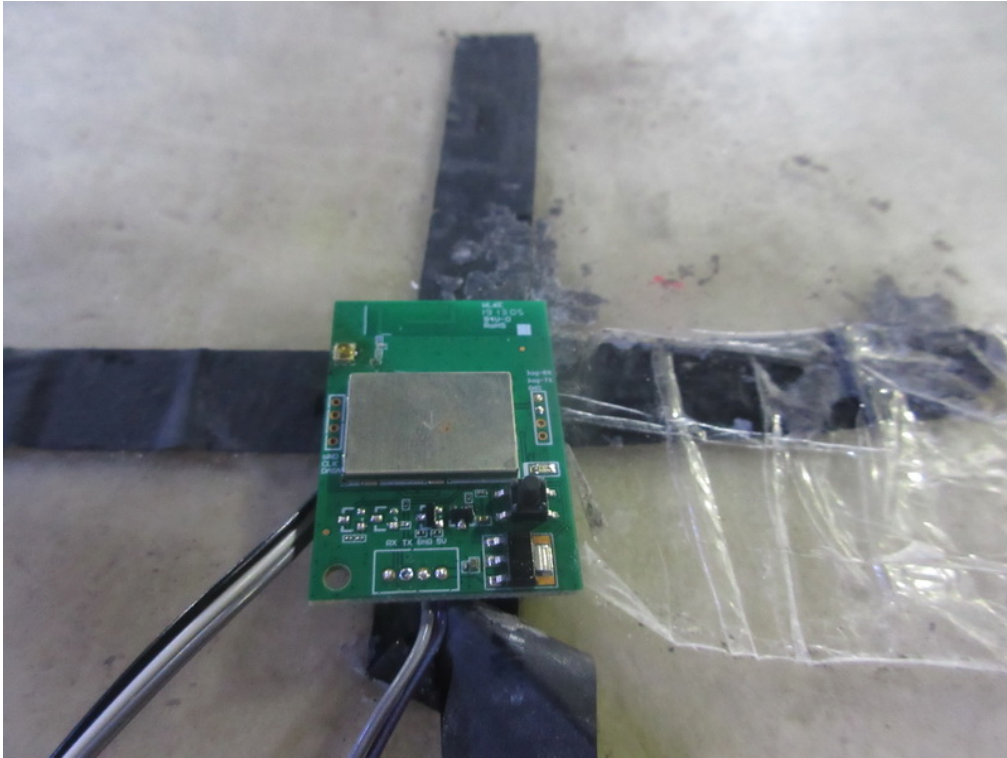



## APPENDIX A - AC POWER LINE CONDUCTED EMISSIONS

Test Mode: TX B MODE CHANNEL 11 (USB Support)

**Line**

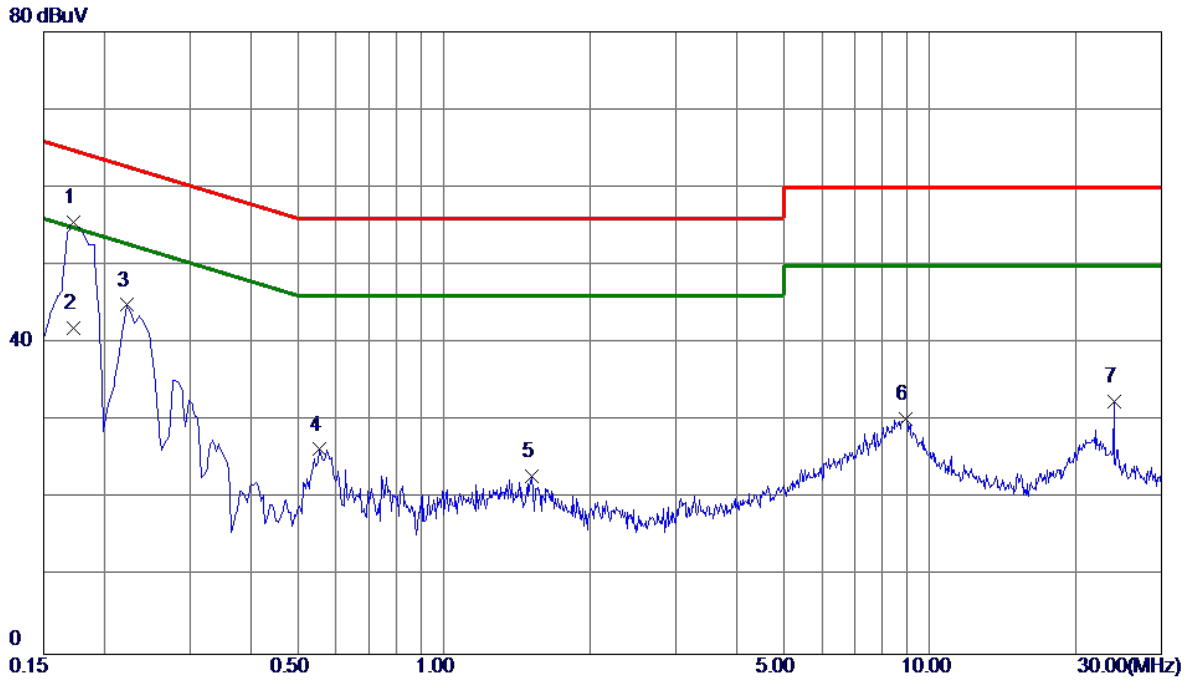

No.	Freq. MHz	Reading Level dBuV	Correct Factor dB	Measure ment dBuV	Limit dBuV	Margin dB	Detector	Comment
1 *	0.1725	45.07	10.47	55.54	64.84	-9.30	Peak	
2	0.1725	31.40	10.47	41.87	54.84	-12.97	AVG	
3	0.2220	34.41	10.47	44.88	62.74	-17.86	Peak	
4	0.5550	15.81	10.51	26.32	56.00	-29.68	Peak	
5	1.5135	12.28	10.60	22.88	56.00	-33.12	Peak	
6	8.8979	19.27	10.91	30.18	60.00	-29.82	Peak	
7	24.0000	21.46	11.01	32.47	60.00	-27.53	Peak	

**REMARKS:**

- (1) Measurement Value = Reading Level + Correct Factor.
- (2) Margin Level = Measurement Value - Limit Value.

Test Mode: TX B MODE CHANNEL 11 (USB Support)

Neutral

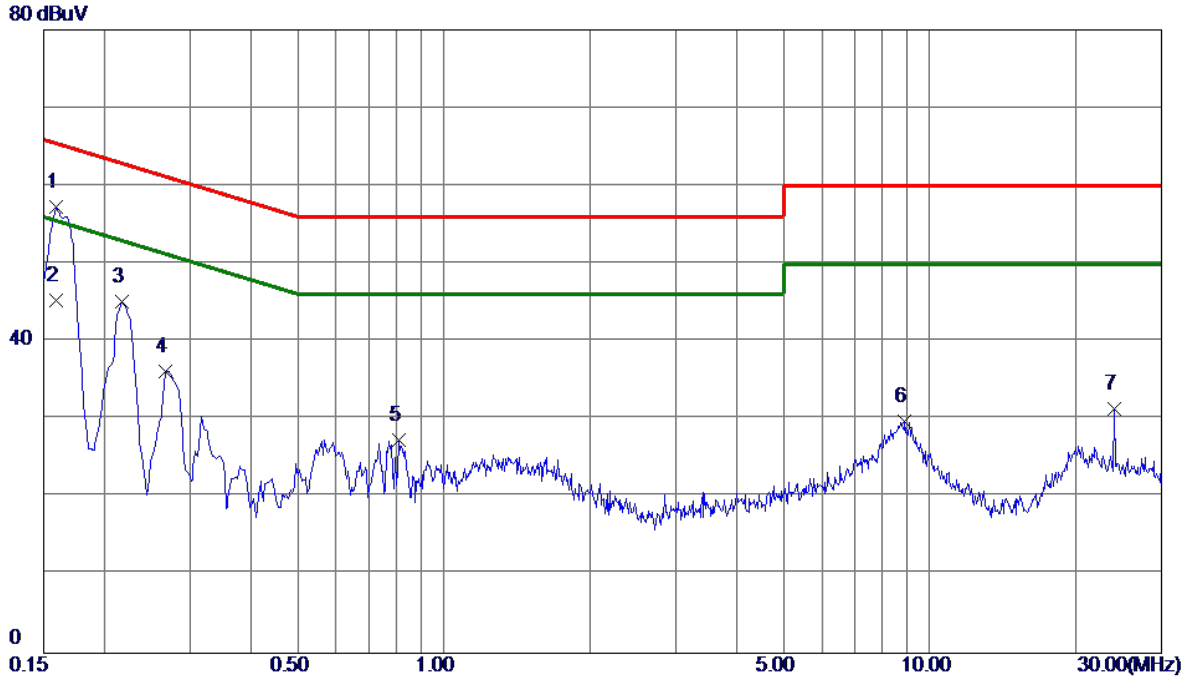

No.	Freq. MHz	Reading Level dBuV	Correct Factor dB	Measure ment dBuV	Limit dBuV	Margin dB	Detector	Comment
1 *	0.1590	46.88	10.43	57.31	65.52	-8.21	Peak	
2	0.1590	34.90	10.43	45.33	55.52	-10.19	AVG	
3	0.2175	34.59	10.46	45.05	62.91	-17.86	Peak	
4	0.2670	25.70	10.46	36.16	61.21	-25.05	Peak	
5	0.8070	16.84	10.50	27.34	56.00	-28.66	Peak	
6	8.8935	18.94	10.86	29.80	60.00	-30.20	Peak	
7	24.0000	20.40	11.01	31.41	60.00	-28.59	Peak	

REMARKS:

- (1) Measurement Value = Reading Level + Correct Factor.
- (2) Margin Level = Measurement Value - Limit Value.

## APPENDIX B - RADIATED EMISSION - 9 KHZ TO 30 MHZ

Test Mode: TX B MODE CHANNEL 11

**Ant 0°**

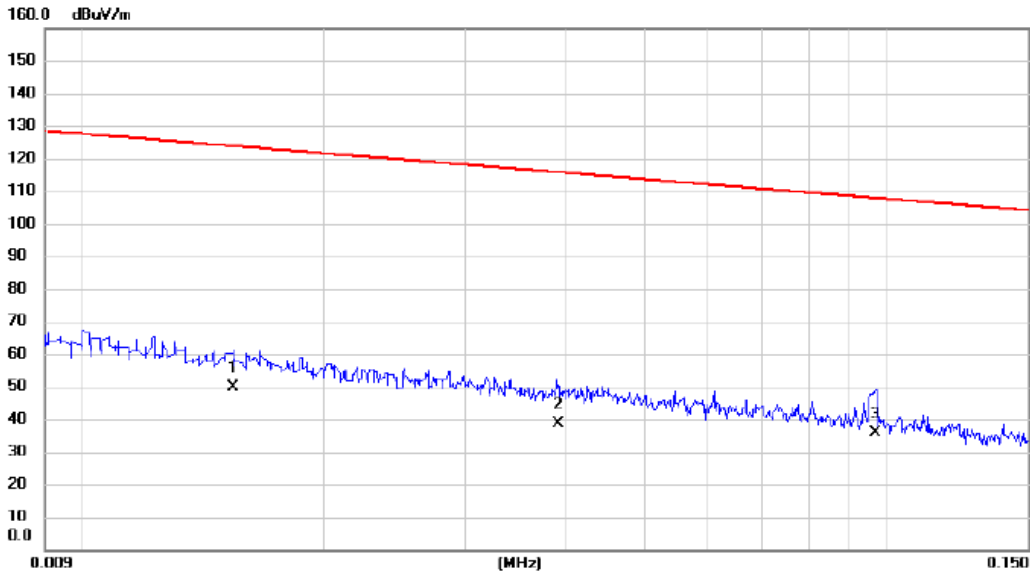

No.	Mk.	Freq. MHz	Reading Level dBuV	Correct Factor dB	Measure- ment dBuV/m	Limit dBuV/m	Margin dB	Detector	Comment
1		0.0154	34.60	15.20	49.80	123.85	-74.05	AVG	
2		0.0391	24.80	13.89	38.69	115.76	-77.07	AVG	
3	*	0.0970	22.30	13.54	35.84	107.87	-72.03	QP	

**REMARKS:**

- (1) Measurement Value = Reading Level + Correct Factor.
- (2) Margin Level = Measurement Value - Limit Value.

Test Mode: TX B MODE CHANNEL 11

Ant 0°

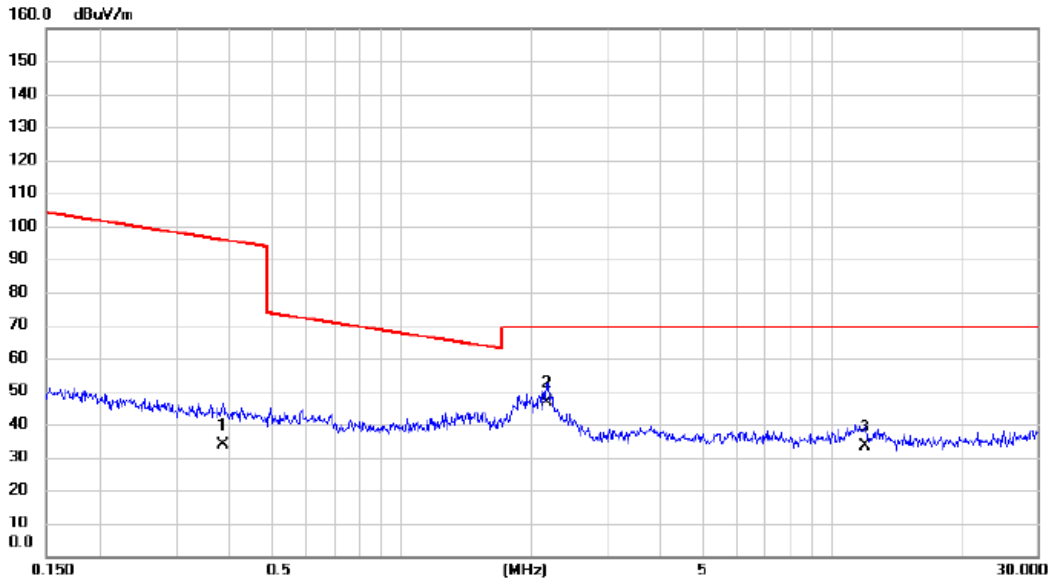

No.	Mk.	Freq. MHz	Reading Level dBuV	Correct Factor dB	Measure- ment dBuV/m	Limit dBuV/m	Margin dB	Detector	Comment
1		0.3851	20.60	13.34	33.94	95.89	-61.95	AVG	
2	*	2.1781	34.80	11.71	46.51	69.54	-23.03	QP	
3		11.9327	21.60	11.61	33.21	69.54	-36.33	QP	

REMARKS:

(1) Measurement Value = Reading Level + Correct Factor.

(2) Margin Level = Measurement Value - Limit Value.

Test Mode: TX B MODE CHANNEL 11

**Ant 90°**

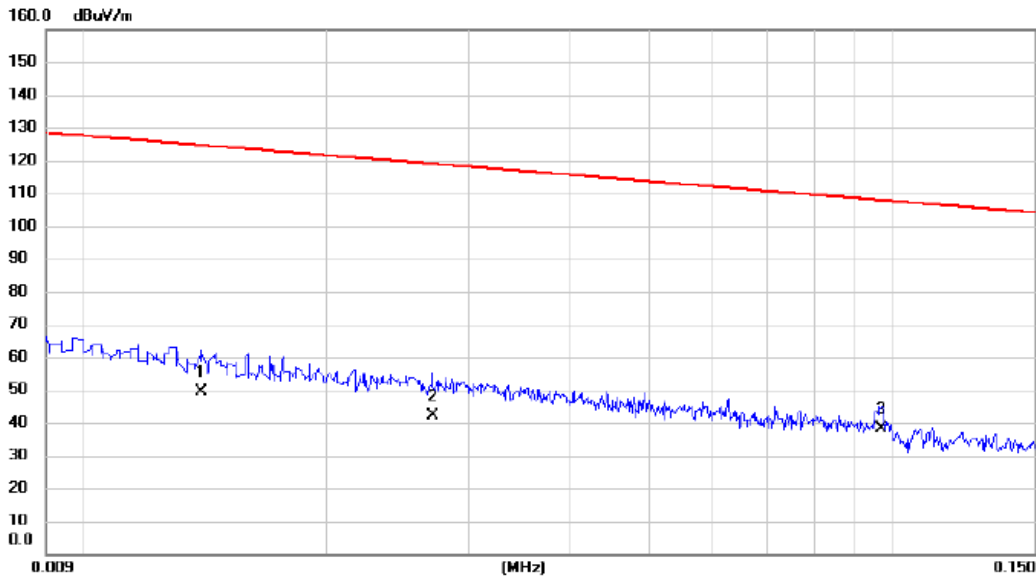

No.	Mk.	Freq. MHz	Reading Level dBuV	Correct Factor dB	Measure- ment dBuV/m	Limit dBuV/m	Margin dB	Detector	Comment
1		0.0140	33.60	15.62	49.22	124.68	-75.46	AVG	
2		0.0271	28.50	13.84	42.34	118.95	-76.61	AVG	
3	*	0.0970	24.60	13.54	38.14	107.87	-69.73	QP	

**REMARKS:**

- (1) Measurement Value = Reading Level + Correct Factor.
- (2) Margin Level = Measurement Value - Limit Value.

Test Mode: TX B MODE CHANNEL 11

Ant 90°

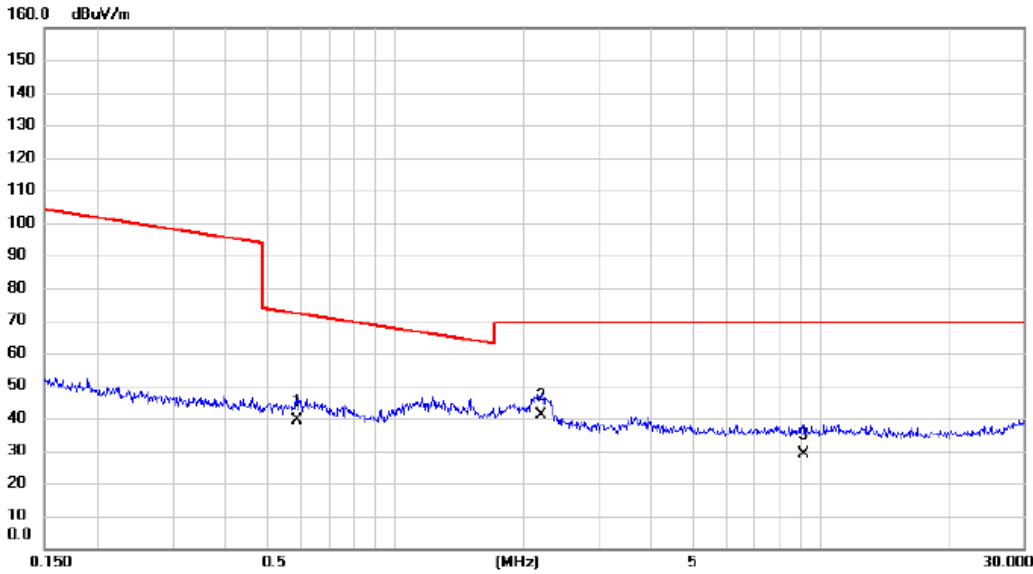

No.	Mk.	Freq. MHz	Reading Level dBuV	Correct Factor dB	Measure- ment dBuV/m	Limit dBuV/m	Margin dB	Detector	Comment
1		0.5885	26.40	12.89	39.29	72.21	-32.92	QP	
2	*	2.2015	29.30	11.70	41.00	69.54	-28.54	QP	
3		9.1073	17.40	11.50	28.90	69.54	-40.64	QP	

**REMARKS:**

- (1) Measurement Value = Reading Level + Correct Factor.
- (2) Margin Level = Measurement Value - Limit Value.



## APPENDIX C - RADIATED EMISSION - 30 MHZ TO 1000 MHZ

Test Mode: TX B MODE CHANNEL 11

Vertical

80 dBuV/m

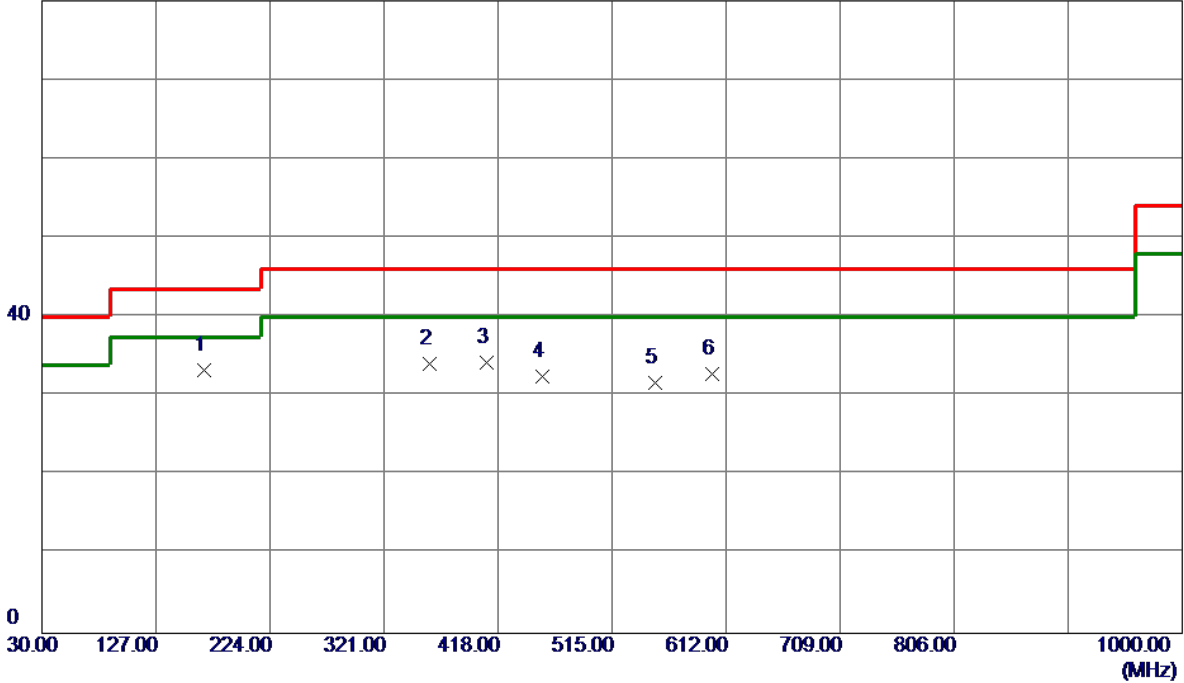

No.	Freq. MHz	Reading Level dBuV/m	Correct Factor dB	Measure ment dBuV/m	Limit dBuV/m	Margin dB	Detector	Comment
1 *	168.2250	45.58	-12.23	33.35	43.50	-10.15	Peak	
2	359.8000	44.65	-10.51	34.14	46.00	-11.86	Peak	
3	407.8150	43.59	-9.32	34.27	46.00	-11.73	Peak	
4	455.8300	40.60	-8.10	32.50	46.00	-13.50	Peak	
5	551.8600	38.96	-7.22	31.74	46.00	-14.26	Peak	
6	599.8750	38.65	-5.80	32.85	46.00	-13.15	Peak	

REMARKS:

- (1) Measurement Value = Reading Level + Correct Factor.
- (2) Margin Level = Measurement Value - Limit Value.

Test Mode: TX B MODE CHANNEL 11

Horizontal

80 dBuV/m

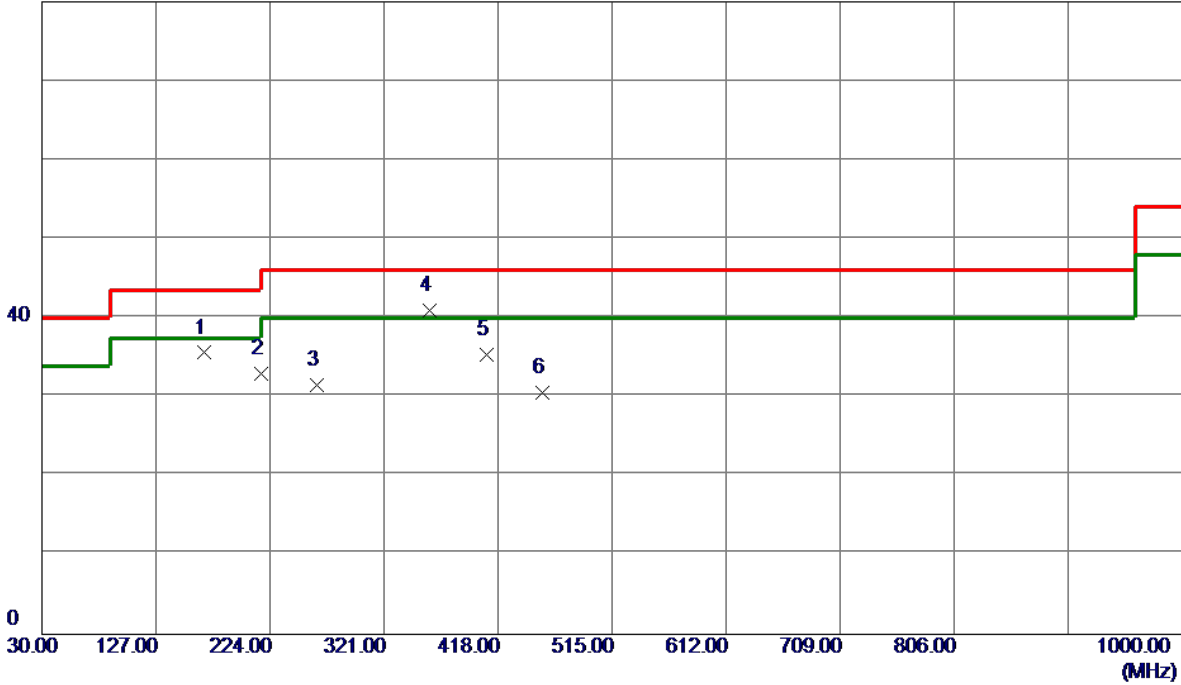

No.	Freq. MHz	Reading Level dBuV/m	Correct Factor dB	Measure ment dBuV/m	Limit dBuV/m	Margin dB	Detector	Comment
1	168.2250	47.83	-12.23	35.60	43.50	-7.90	Peak	
2	216.2400	48.02	-15.07	32.95	46.00	-13.05	Peak	
3	263.7700	44.45	-12.89	31.56	46.00	-14.44	Peak	
4 *	359.8000	51.52	-10.51	41.01	46.00	-4.99	Peak	
5	407.8150	44.75	-9.32	35.43	46.00	-10.57	Peak	
6	455.8300	38.64	-8.10	30.54	46.00	-15.46	Peak	

REMARKS:

- (1) Measurement Value = Reading Level + Correct Factor.
- (2) Margin Level = Measurement Value - Limit Value.

## APPENDIX D - RADIATED EMISSION- ABOVE 1000 MHZ

Orthogonal Axis	X
Test Mode:	TX B Mode 2412 MHz

**Vertical**

130 dBuV/m

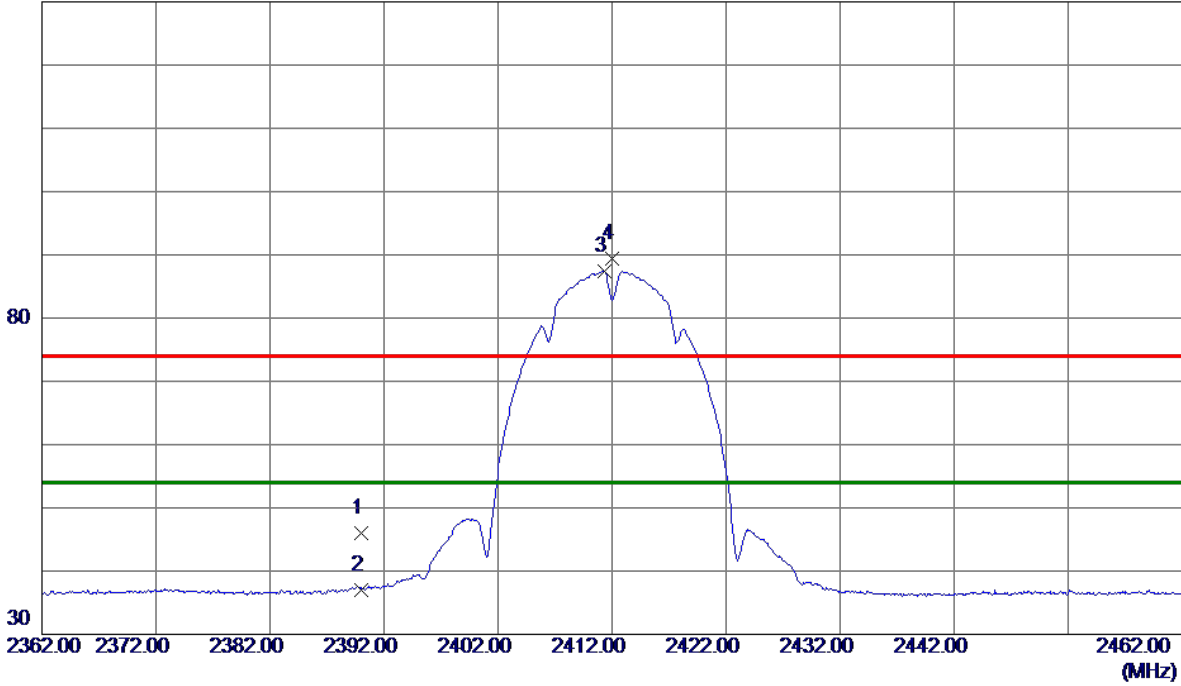

No.	Freq. MHz	Reading Level dBuV/m	Correct Factor dB	Measure ment dBuV/m	Limit dBuV/m	Margin dB	Detector	Comment
1	2390.0000	39.56	6.53	46.09	74.00	-27.91	Peak	
2	2390.0000	30.56	6.53	37.09	54.00	-16.91	AVG	
3 *	2411.3000	80.91	6.51	87.42	54.00	33.42	AVG	No Limit
4	2411.9500	82.98	6.51	89.49	74.00	15.49	Peak	No Limit

**REMARKS:**

- (1) Measurement Value = Reading Level + Correct Factor.
- (2) Margin Level = Measurement Value - Limit Value.

Orthogonal Axis	X
Test Mode:	TX B Mode 2412 MHz

**Vertical**

80 dBuV/m

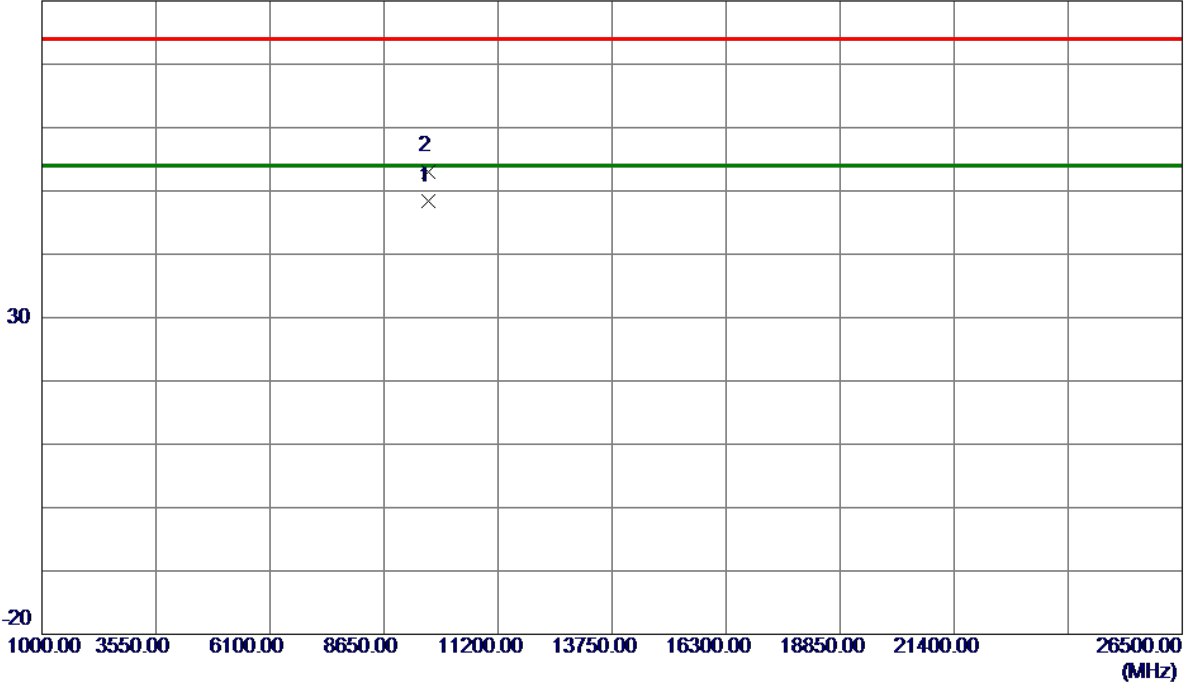

No.	Freq. MHz	Reading Level dBuV/m	Correct Factor dB	Measure ment dBuV/m	Limit dBuV/m	Margin dB	Detector	Comment
1 *	9648.1289	37.79	10.70	48.49	54.00	-5.51	AVG	
2	9648.1730	42.40	10.70	53.10	74.00	-20.90	Peak	

**REMARKS:**

- (1) Measurement Value = Reading Level + Correct Factor.
- (2) Margin Level = Measurement Value - Limit Value.

Orthogonal Axis	X
Test Mode:	TX B Mode 2412 MHz

**Horizontal**

130 dBuV/m

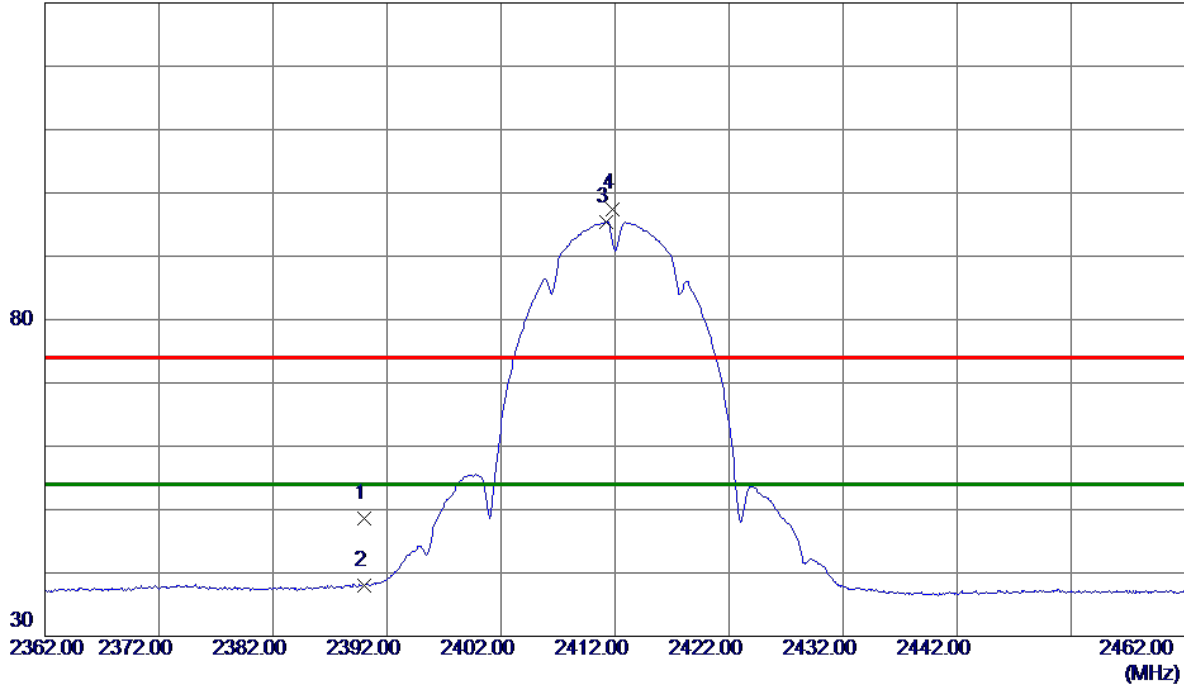

No.	Freq. MHz	Reading Level dBuV/m	Correct Factor dB	Measure ment dBuV/m	Limit dBuV/m	Margin dB	Detector	Comment
1	2390.0000	42.02	6.53	48.55	74.00	-25.45	Peak	
2	2390.0000	31.56	6.53	38.09	54.00	-15.91	AVG	
3 *	2411.2500	88.97	6.51	95.48	54.00	41.48	AVG	No Limit
4	2411.7500	90.99	6.51	97.50	74.00	23.50	Peak	No Limit

**REMARKS:**

- (1) Measurement Value = Reading Level + Correct Factor.
- (2) Margin Level = Measurement Value - Limit Value.

Orthogonal Axis	X
Test Mode:	TX B Mode 2412 MHz

**Horizontal**

80 dBuV/m

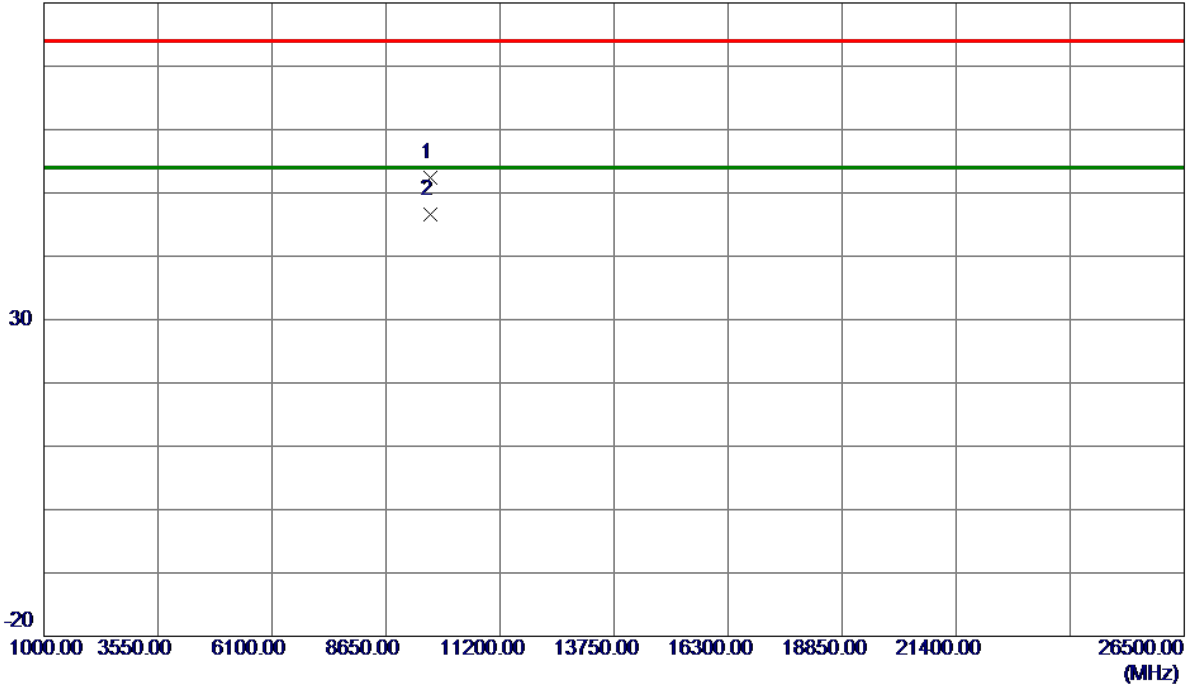

No.	Freq. MHz	Reading Level dBuV/m	Correct Factor dB	Measure ment dBuV/m	Limit dBuV/m	Margin dB	Detector	Comment
1	9648.0870	41.61	10.70	52.31	74.00	-21.69	Peak	
2 *	9648.1130	35.82	10.70	46.52	54.00	-7.48	AVG	

**REMARKS:**

- (1) Measurement Value = Reading Level + Correct Factor.
- (2) Margin Level = Measurement Value - Limit Value.



Orthogonal Axis	X
Test Mode:	TX B Mode 2437 MHz

**Vertical**

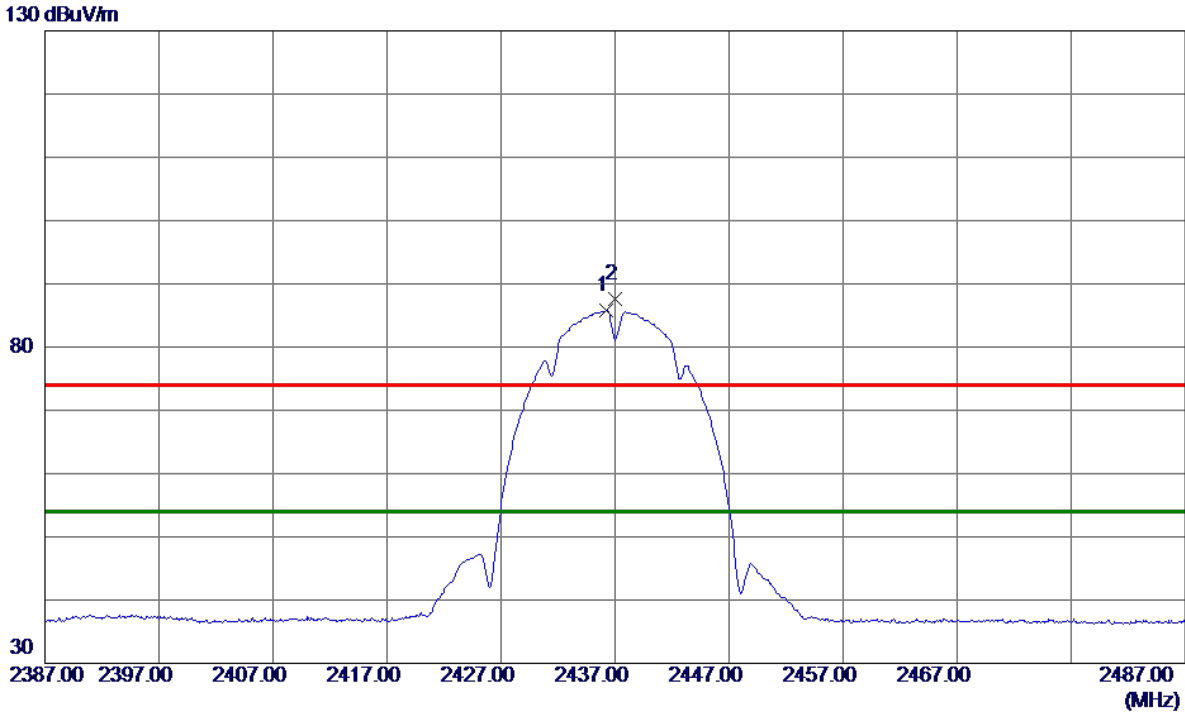

No.	Freq. MHz	Reading Level dBuV/m	Correct Factor dB	Measure ment dBuV/m	Limit dBuV/m	Margin dB	Detector	Comment
1 *	2436.2500	79.26	6.48	85.74	54.00	31.74	AVG	No Limit
2	2436.9500	81.07	6.48	87.55	74.00	13.55	Peak	No Limit

**REMARKS:**

- (1) Measurement Value = Reading Level + Correct Factor.
- (2) Margin Level = Measurement Value - Limit Value.

Orthogonal Axis	X
Test Mode:	TX B Mode 2437 MHz

**Vertical**

80 dBuV/m

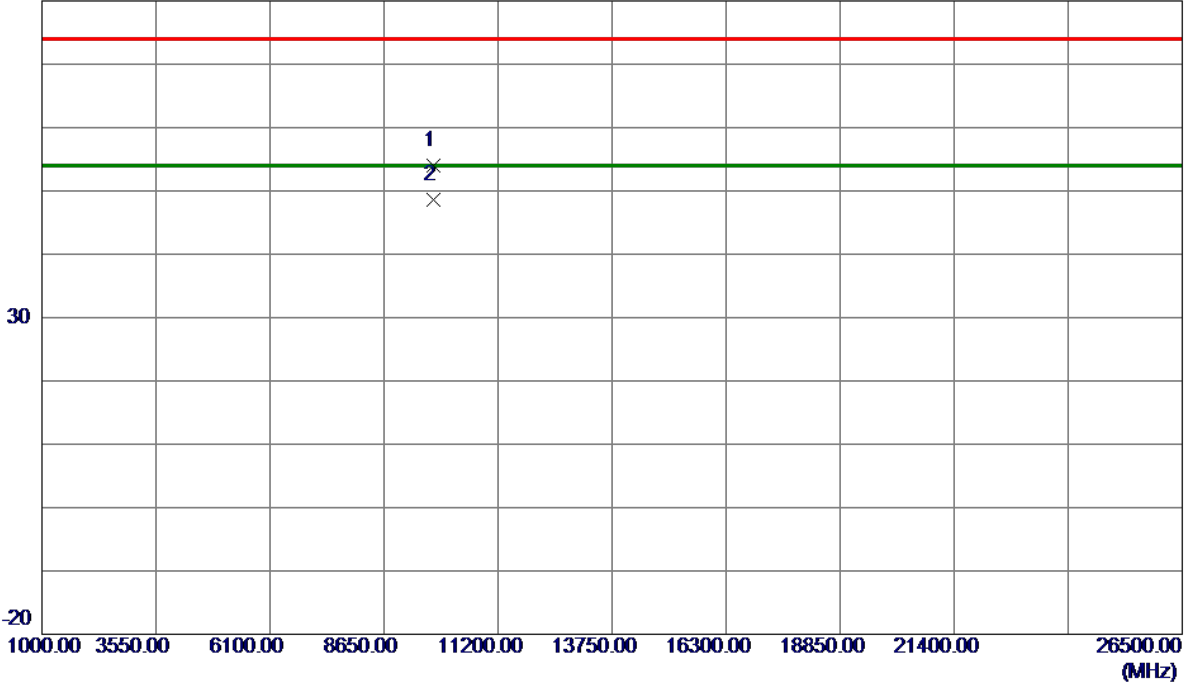

No.	Freq. MHz	Reading Level dBuV/m	Correct Factor dB	Measure ment dBuV/m	Limit dBuV/m	Margin dB	Detector	Comment
1	9748.0610	43.33	10.70	54.03	74.00	-19.97	Peak	
2 *	9748.0990	37.89	10.70	48.59	54.00	-5.41	AVG	

**REMARKS:**

- (1) Measurement Value = Reading Level + Correct Factor.
- (2) Margin Level = Measurement Value - Limit Value.

Orthogonal Axis	X
Test Mode:	TX B Mode 2437 MHz

**Horizontal**

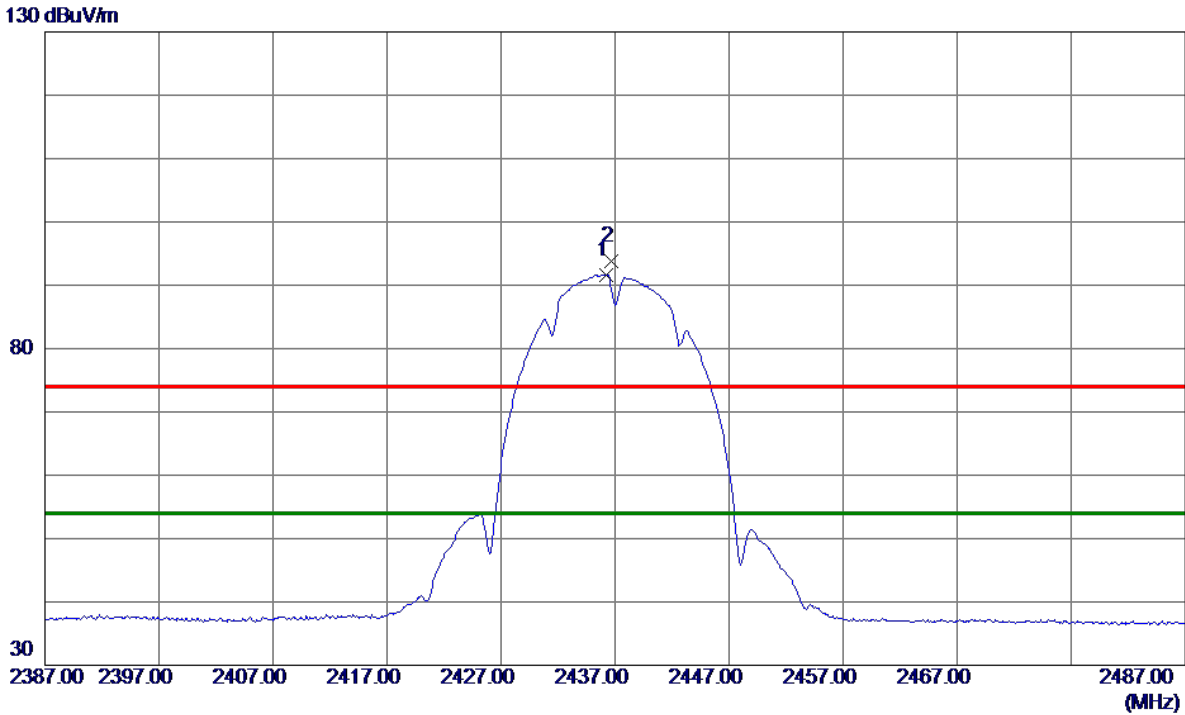

No.	Freq. MHz	Reading Level dBuV/m	Correct Factor dB	Measure ment dBuV/m	Limit dBuV/m	Margin dB	Detector	Comment
1 *	2436.2500	85.19	6.48	91.67	54.00	37.67	AVG	No Limit
2	2436.7000	87.24	6.48	93.72	74.00	19.72	Peak	No Limit

**REMARKS:**

- (1) Measurement Value = Reading Level + Correct Factor.
- (2) Margin Level = Measurement Value - Limit Value.

Orthogonal Axis	X
Test Mode:	TX B Mode 2437 MHz

**Horizontal**

80 dBuV/m

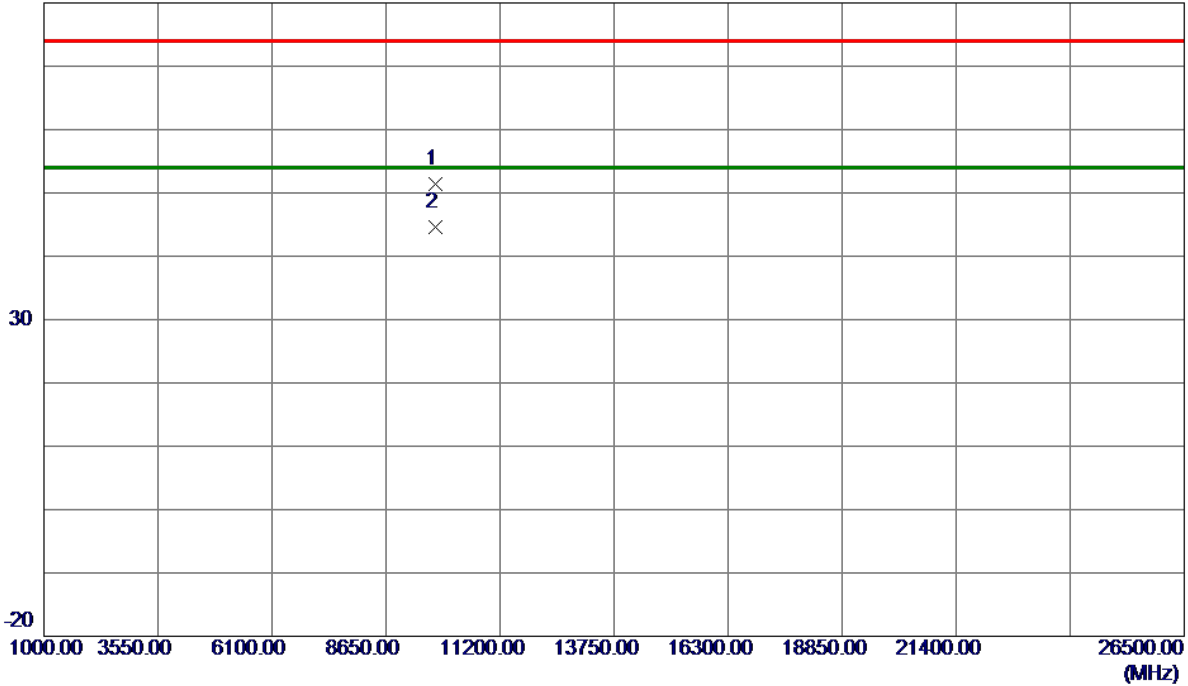

No.	Freq. MHz	Reading Level dBuV/m	Correct Factor dB	Measure ment dBuV/m	Limit dBuV/m	Margin dB	Detector	Comment
1	9748.0220	40.74	10.70	51.44	74.00	-22.56	Peak	
2 *	9748.1220	33.89	10.70	44.59	54.00	-9.41	AVG	

**REMARKS:**

- (1) Measurement Value = Reading Level + Correct Factor.
- (2) Margin Level = Measurement Value - Limit Value.

Orthogonal Axis	X
Test Mode:	TX B Mode 2462 MHz

**Vertical**

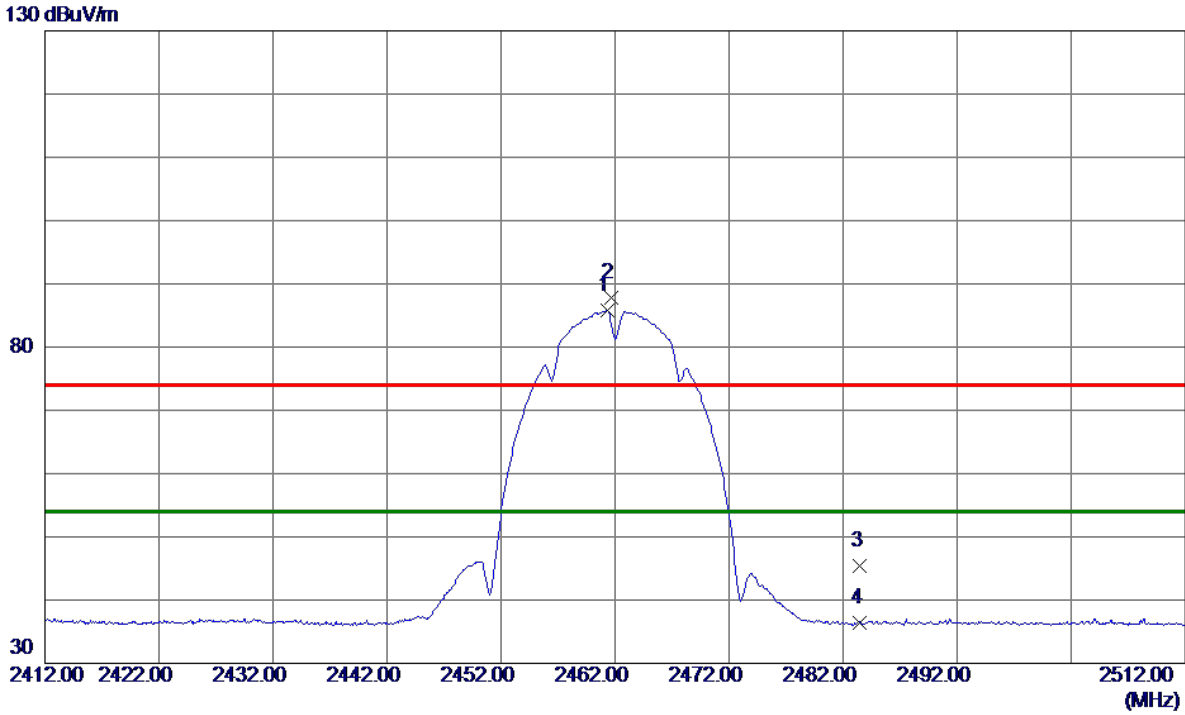

No.	Freq. MHz	Reading Level dBuV/m	Correct Factor dB	Measure ment dBuV/m	Limit dBuV/m	Margin dB	Detector	Comment
1 *	2461.3000	79.32	6.45	85.77	54.00	31.77	AVG	No Limit
2	2461.6500	81.36	6.45	87.81	74.00	13.81	Peak	No Limit
3	2483.5000	38.95	6.42	45.37	74.00	-28.63	Peak	
4	2483.5000	29.93	6.42	36.35	54.00	-17.65	AVG	

**REMARKS:**

- (1) Measurement Value = Reading Level + Correct Factor.
- (2) Margin Level = Measurement Value - Limit Value.

Orthogonal Axis	X
Test Mode:	TX B Mode 2462 MHz

**Vertical**

80 dBuV/m

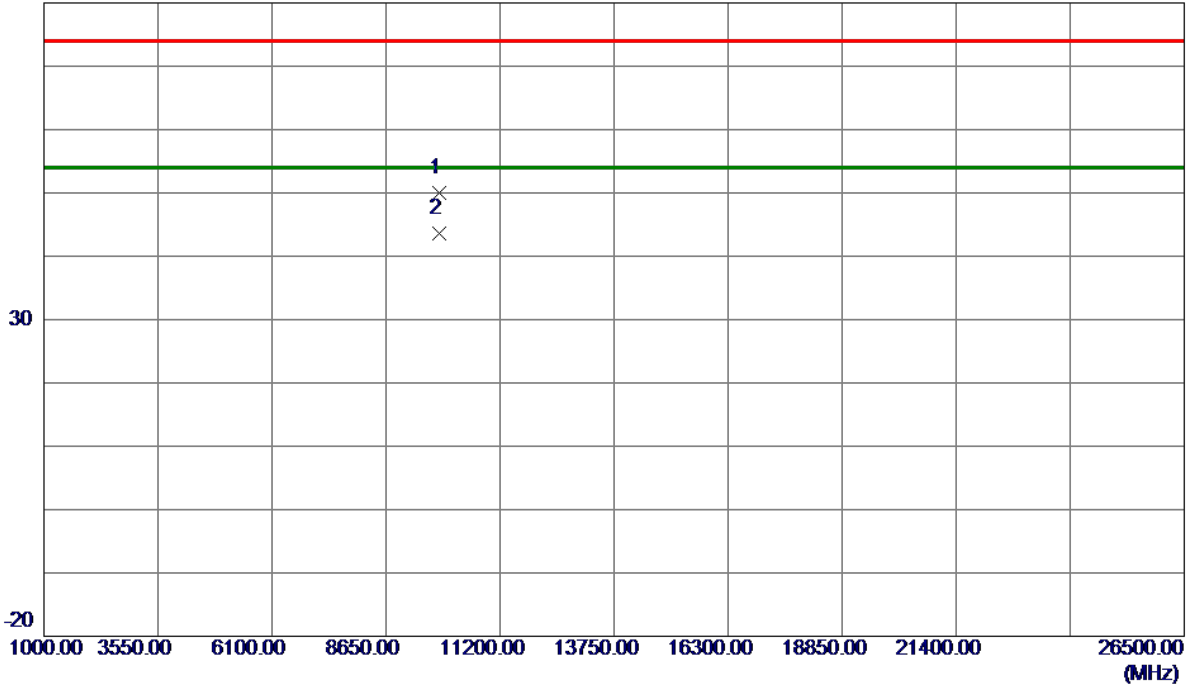

No.	Freq. MHz	Reading Level dBuV/m	Correct Factor dB	Measure ment dBuV/m	Limit dBuV/m	Margin dB	Detector	Comment
1	9848.1230	39.26	10.69	49.95	74.00	-24.05	Peak	
2 *	9848.1270	32.86	10.69	43.55	54.00	-10.45	AVG	

**REMARKS:**

- (1) Measurement Value = Reading Level + Correct Factor.
- (2) Margin Level = Measurement Value - Limit Value.

Orthogonal Axis	X
Test Mode:	TX B Mode 2462 MHz

**Horizontal**

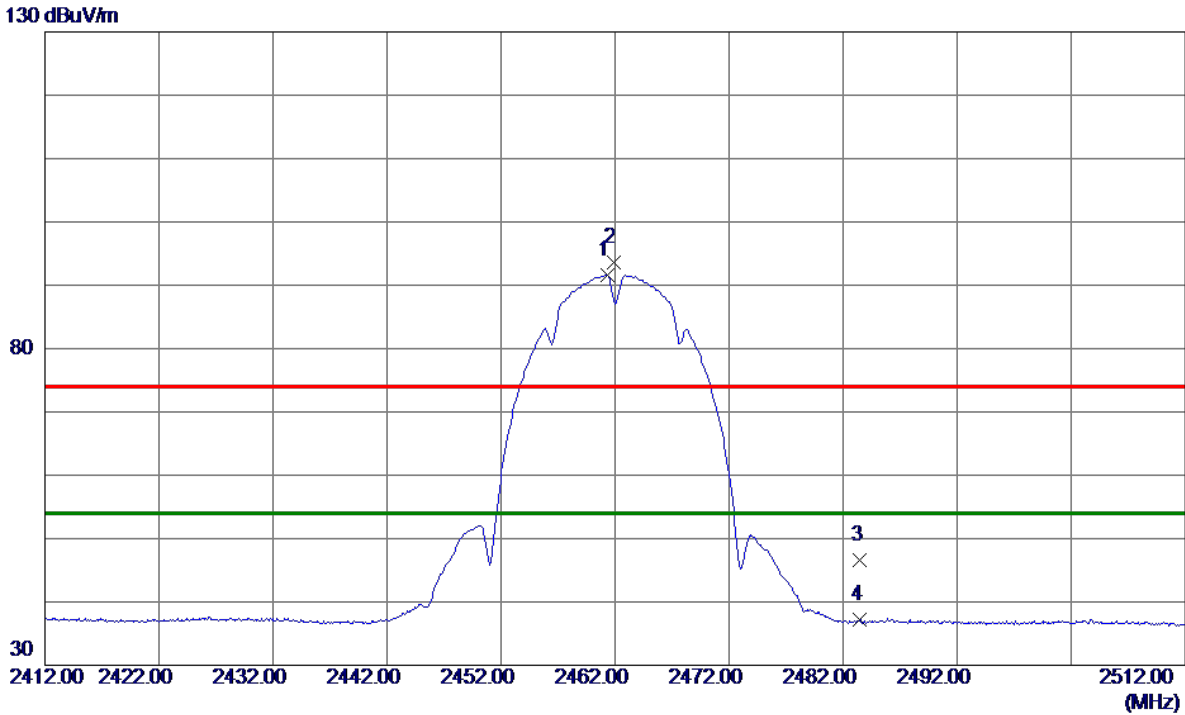

No.	Freq. MHz	Reading Level dBuV/m	Correct Factor dB	Measure ment dBuV/m	Limit dBuV/m	Margin dB	Detector	Comment
1 *	2461.3000	85.19	6.45	91.64	54.00	37.64	AVG	No Limit
2	2461.9000	87.16	6.45	93.61	74.00	19.61	Peak	No Limit
3	2483.5000	40.17	6.42	46.59	74.00	-27.41	Peak	
4	2483.5000	30.73	6.42	37.15	54.00	-16.85	AVG	

**REMARKS:**

- (1) Measurement Value = Reading Level + Correct Factor.
- (2) Margin Level = Measurement Value - Limit Value.

Orthogonal Axis	X
Test Mode:	TX B Mode 2462 MHz

**Horizontal**

80 dBuV/m

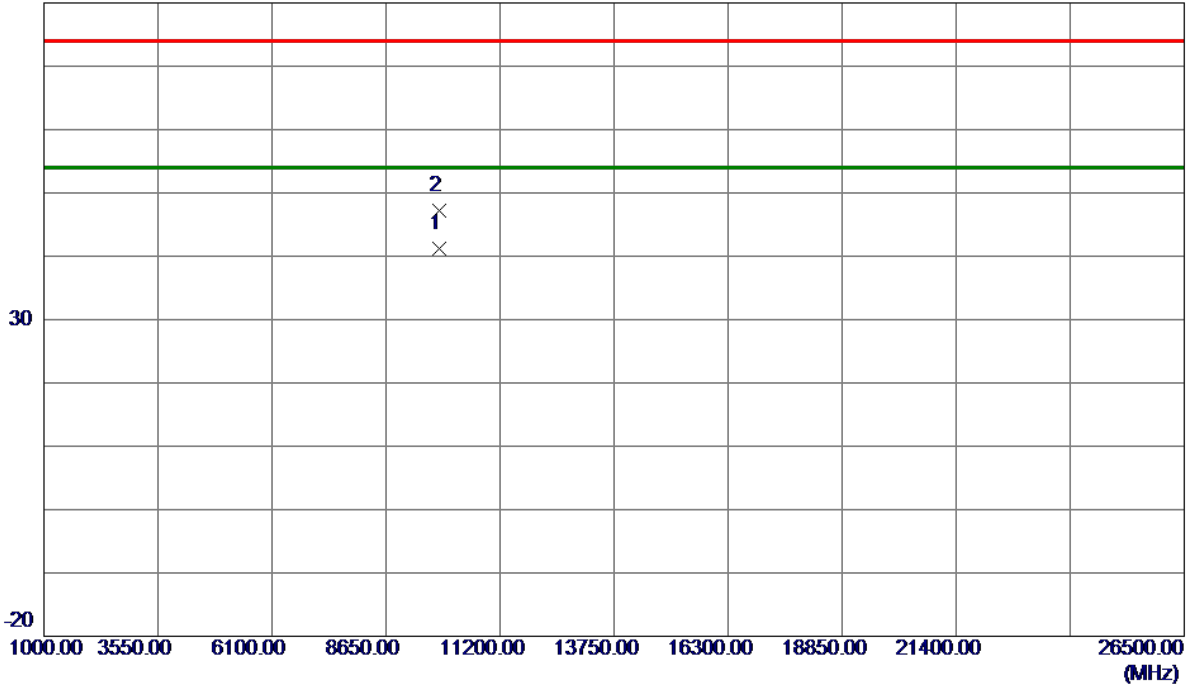

No.	Freq. MHz	Reading Level dBuV/m	Correct Factor dB	Measure ment dBuV/m	Limit dBuV/m	Margin dB	Detector	Comment
1 *	9848.1550	30.52	10.69	41.21	54.00	-12.79	AVG	
2	9848.2150	36.59	10.69	47.28	74.00	-26.72	Peak	

**REMARKS:**

- (1) Measurement Value = Reading Level + Correct Factor.
- (2) Margin Level = Measurement Value - Limit Value.



Orthogonal Axis	X
Test Mode:	TX G Mode 2412 MHz

**Vertical**

130 dBuV/m

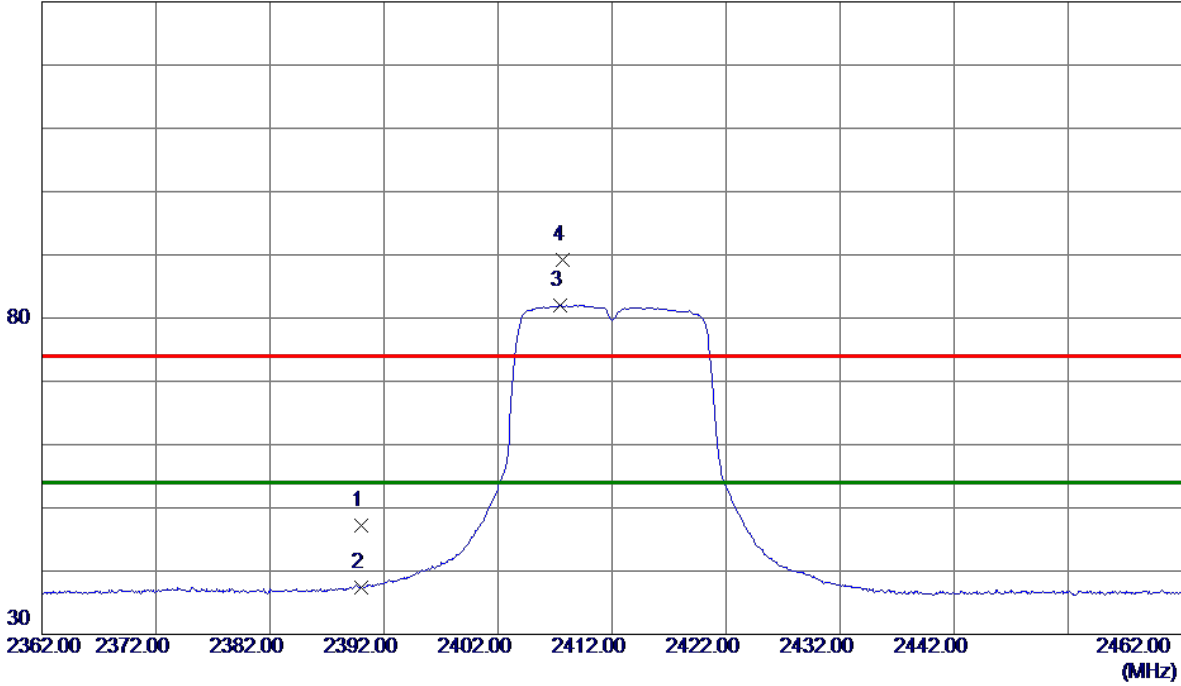

No.	Freq. MHz	Reading Level dBuV/m	Correct Factor dB	Measure ment dBuV/m	Limit dBuV/m	Margin dB	Detector	Comment
1	2390.0000	40.69	6.53	47.22	74.00	-26.78	Peak	
2	2390.0000	30.93	6.53	37.46	54.00	-16.54	AVG	
3 *	2407.4000	75.46	6.51	81.97	54.00	27.97	AVG	No Limit
4	2407.6500	82.64	6.51	89.15	74.00	15.15	Peak	No Limit

**REMARKS:**

- (1) Measurement Value = Reading Level + Correct Factor.
- (2) Margin Level = Measurement Value - Limit Value.

Orthogonal Axis	X
Test Mode:	TX G Mode 2412 MHz

**Vertical**

80 dBuV/m

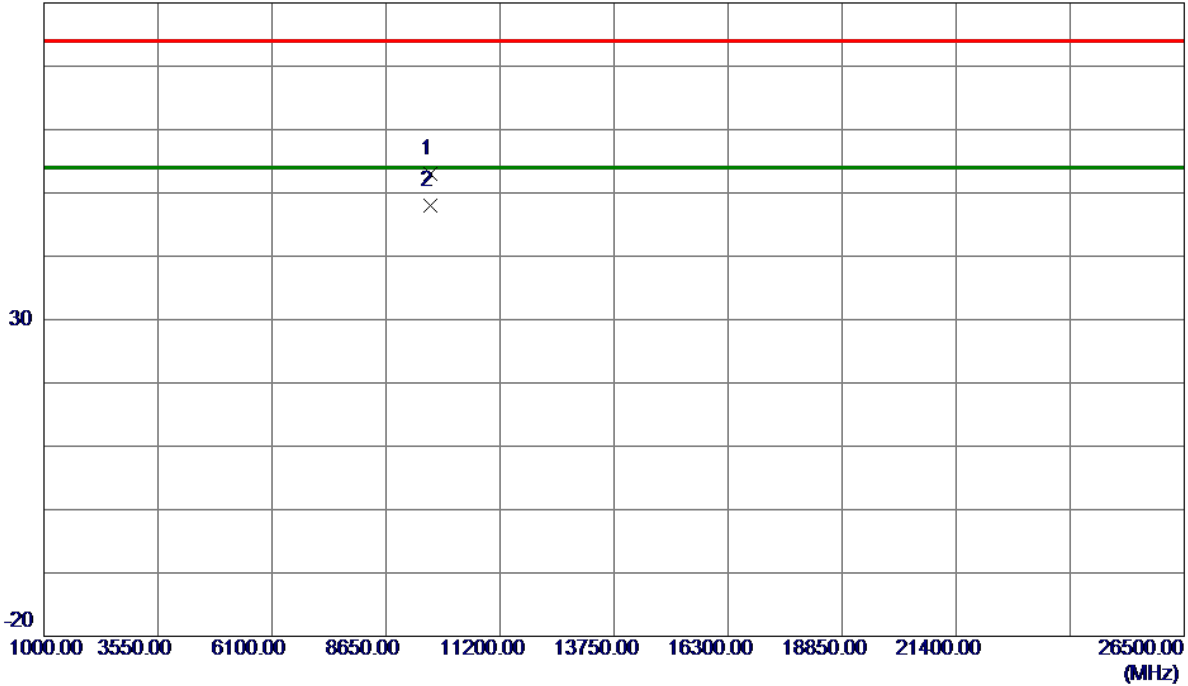

No.	Freq. MHz	Reading Level dBuV/m	Correct Factor dB	Measure ment dBuV/m	Limit dBuV/m	Margin dB	Detector	Comment
1	9648.1230	42.21	10.70	52.91	74.00	-21.09	Peak	
2 *	9648.1280	37.24	10.70	47.94	54.00	-6.06	AVG	

**REMARKS:**

- (1) Measurement Value = Reading Level + Correct Factor.
- (2) Margin Level = Measurement Value - Limit Value.

Orthogonal Axis	X
Test Mode:	TX G Mode 2412 MHz

### Horizontal

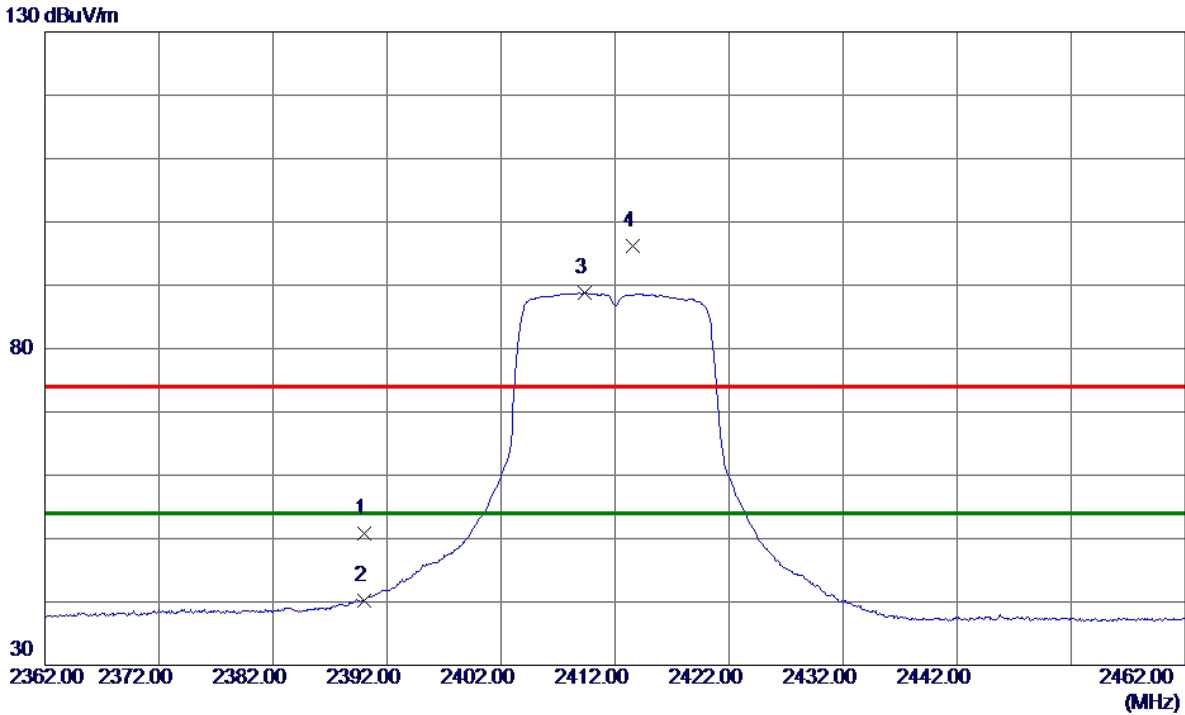

No.	Freq. MHz	Reading Level dBuV/m	Correct Factor dB	Measure ment dBuV/m	Limit dBuV/m	Margin dB	Detector	Comment
1	2390.0000	44.34	6.53	50.87	74.00	-23.13	Peak	
2	2390.0000	33.67	6.53	40.20	54.00	-13.80	AVG	
3 *	2409.3000	82.24	6.51	88.75	54.00	34.75	AVG	No Limit
4	2413.5500	89.63	6.50	96.13	74.00	22.13	Peak	No Limit

**REMARKS:**

- (1) Measurement Value = Reading Level + Correct Factor.
- (2) Margin Level = Measurement Value - Limit Value.

Orthogonal Axis	X
Test Mode:	TX G Mode 2412 MHz

**Horizontal**

80 dBuV/m

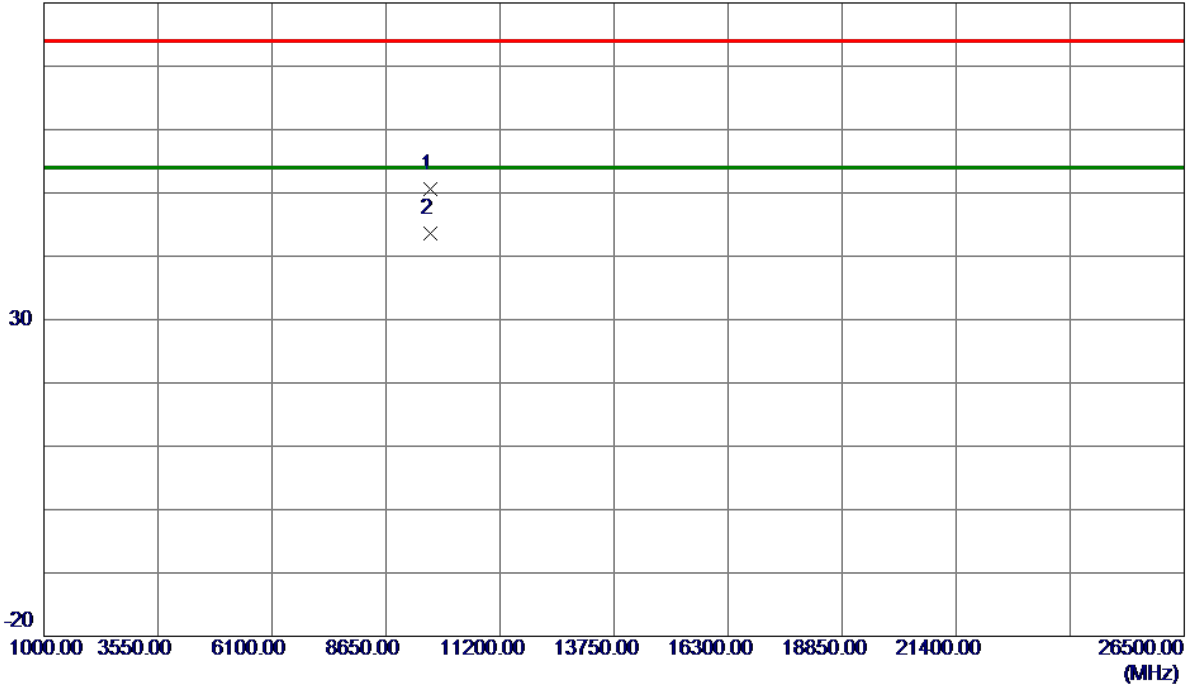

No.	Freq. MHz	Reading Level dBuV/m	Correct Factor dB	Measure ment dBuV/m	Limit dBuV/m	Margin dB	Detector	Comment
1	9648.0900	39.92	10.70	50.62	74.00	-23.38	Peak	
2 *	9648.1920	32.89	10.70	43.59	54.00	-10.41	AVG	

**REMARKS:**

- (1) Measurement Value = Reading Level + Correct Factor.
- (2) Margin Level = Measurement Value - Limit Value.

Orthogonal Axis	X
Test Mode:	TX G Mode 2437 MHz

**Vertical**

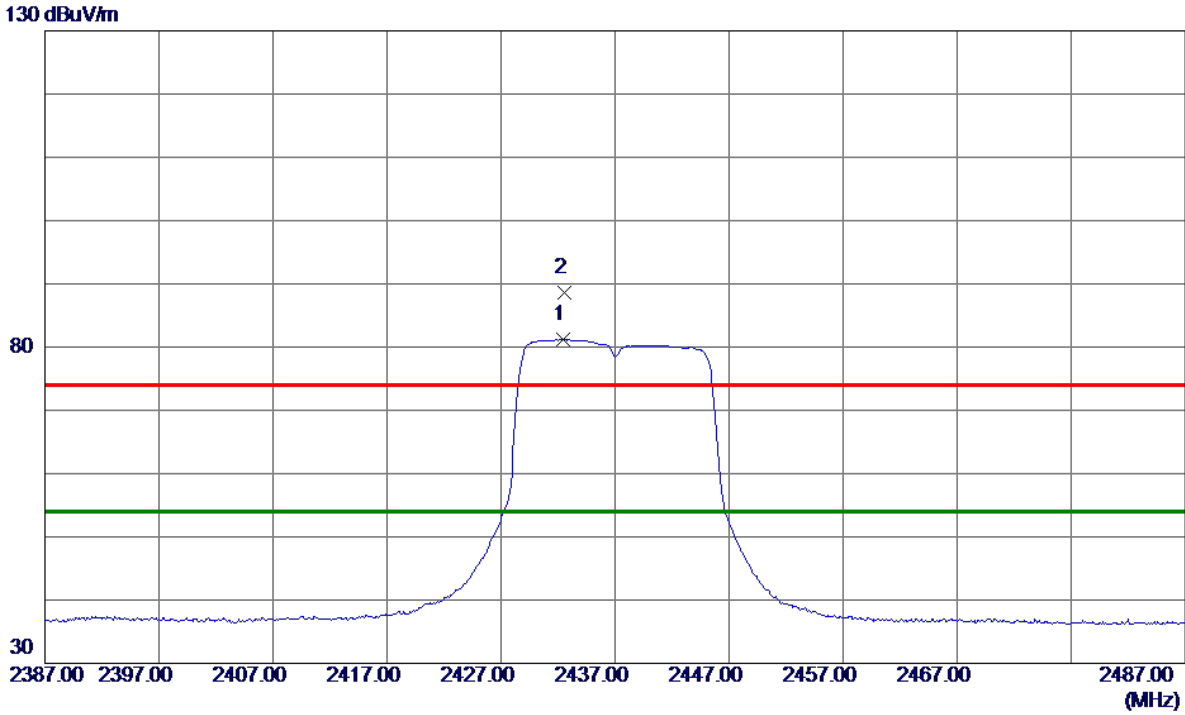

No.	Freq. MHz	Reading Level dBuV/m	Correct Factor dB	Measure ment dBuV/m	Limit dBuV/m	Margin dB	Detector	Comment
1 *	2432.4000	74.73	6.48	81.21	54.00	27.21	AVG	No Limit
2	2432.6000	82.05	6.48	88.53	74.00	14.53	Peak	No Limit

**REMARKS:**

- (1) Measurement Value = Reading Level + Correct Factor.
- (2) Margin Level = Measurement Value - Limit Value.

Orthogonal Axis	X
Test Mode:	TX G Mode 2437 MHz

**Vertical**

80 dBuV/m

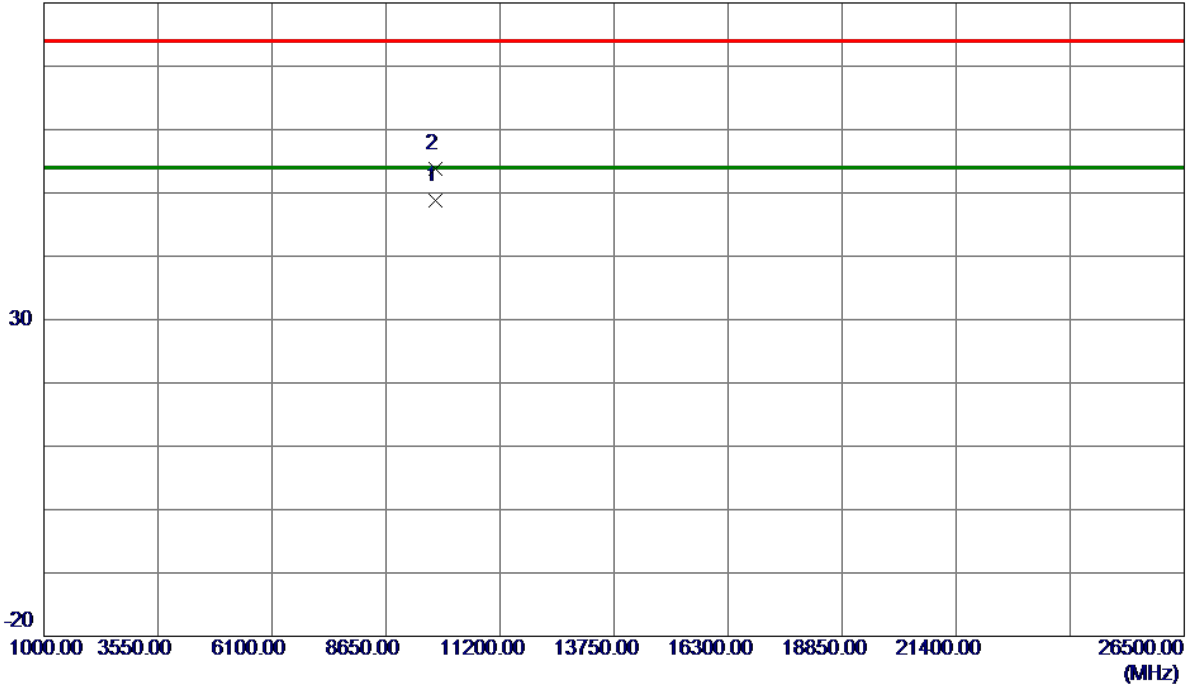

No.	Freq. MHz	Reading Level dBuV/m	Correct Factor dB	Measure ment dBuV/m	Limit dBuV/m	Margin dB	Detector	Comment
1 *	9748.1360	38.14	10.70	48.84	54.00	-5.16	AVG	
2	9748.2009	43.09	10.70	53.79	74.00	-20.21	Peak	

**REMARKS:**

- (1) Measurement Value = Reading Level + Correct Factor.
- (2) Margin Level = Measurement Value - Limit Value.

Orthogonal Axis	X
Test Mode:	TX G Mode 2437 MHz

### Horizontal

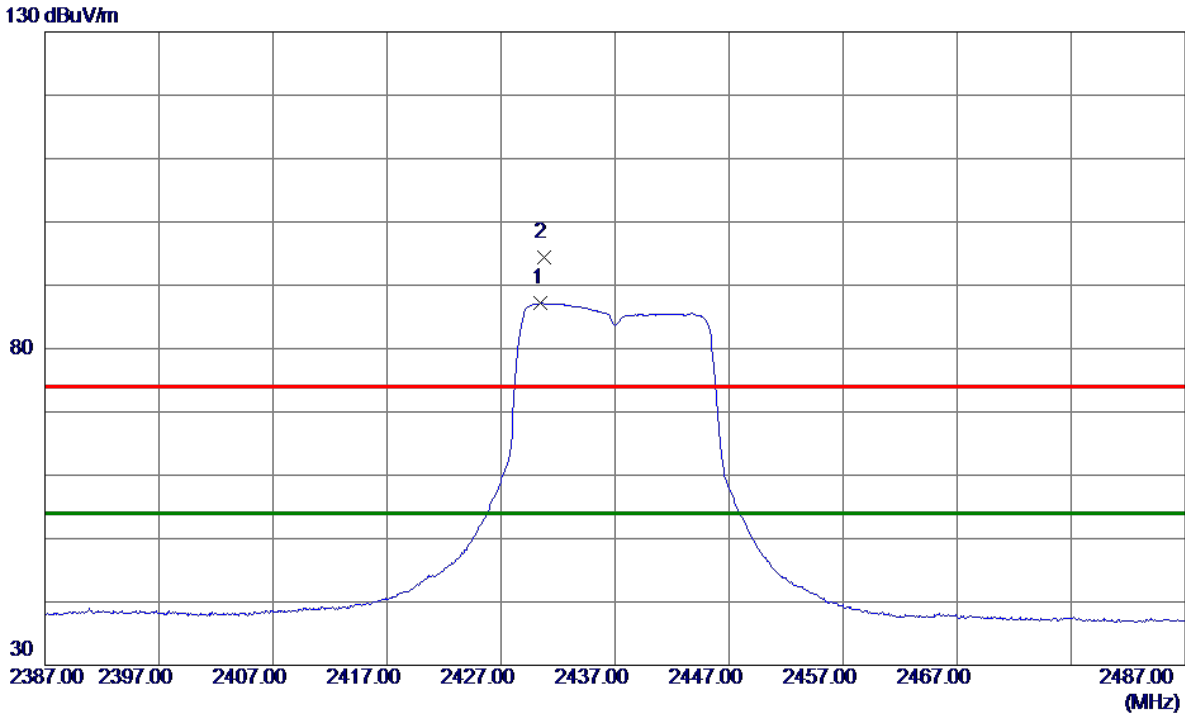

No.	Freq. MHz	Reading Level dBuV/m	Correct Factor dB	Measure ment dBuV/m	Limit dBuV/m	Margin dB	Detector	Comment
1 *	2430.5000	80.66	6.48	87.14	54.00	33.14	AVG	No Limit
2	2430.7500	87.96	6.48	94.44	74.00	20.44	Peak	No Limit

**REMARKS:**

- (1) Measurement Value = Reading Level + Correct Factor.
- (2) Margin Level = Measurement Value - Limit Value.

Orthogonal Axis	X
Test Mode:	TX G Mode 2437 MHz

**Horizontal**

80 dBuV/m

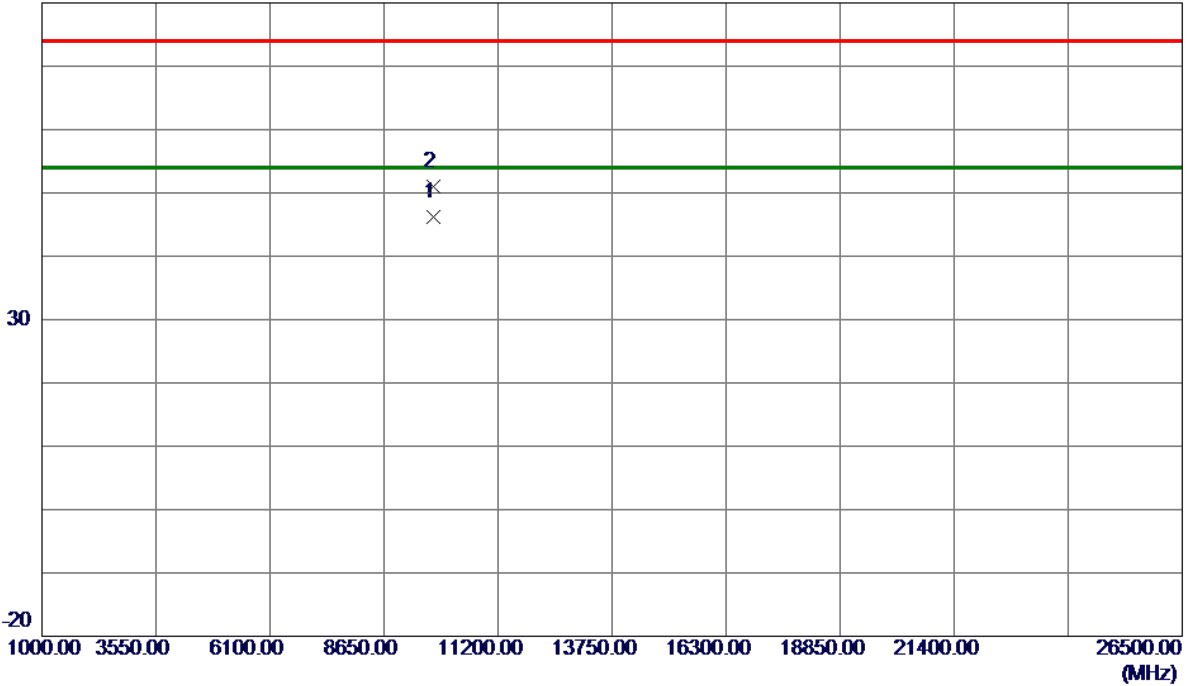

No.	Freq. MHz	Reading Level dBuV/m	Correct Factor dB	Measure ment dBuV/m	Limit dBuV/m	Margin dB	Detector	Comment
1 *	9748.1510	35.52	10.70	46.22	54.00	-7.78	AVG	
2	9748.2030	40.35	10.70	51.05	74.00	-22.95	Peak	

**REMARKS:**

- (1) Measurement Value = Reading Level + Correct Factor.
- (2) Margin Level = Measurement Value - Limit Value.



Orthogonal Axis	X
Test Mode:	TX G Mode 2462 MHz

**Vertical**

130 dBuV/m

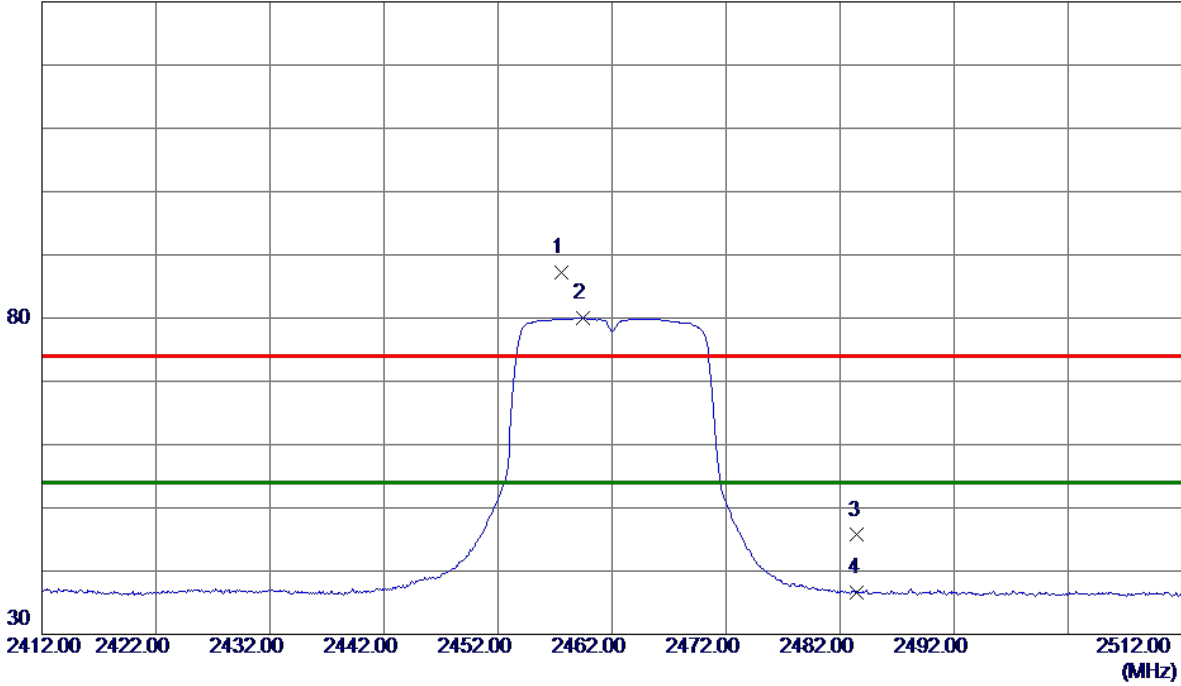

No.	Freq. MHz	Reading Level dBuV/m	Correct Factor dB	Measure ment dBuV/m	Limit dBuV/m	Margin dB	Detector	Comment
1	2457.6000	80.82	6.45	87.27	74.00	13.27	Peak	No Limit
2 *	2459.4500	73.53	6.45	79.98	54.00	25.98	AVG	No Limit
3	2483.5000	39.28	6.42	45.70	74.00	-28.30	Peak	
4	2483.5000	30.18	6.42	36.60	54.00	-17.40	AVG	

**REMARKS:**

- (1) Measurement Value = Reading Level + Correct Factor.
- (2) Margin Level = Measurement Value - Limit Value.

Orthogonal Axis	X
Test Mode:	TX G Mode 2462 MHz

**Vertical**

80 dBuV/m

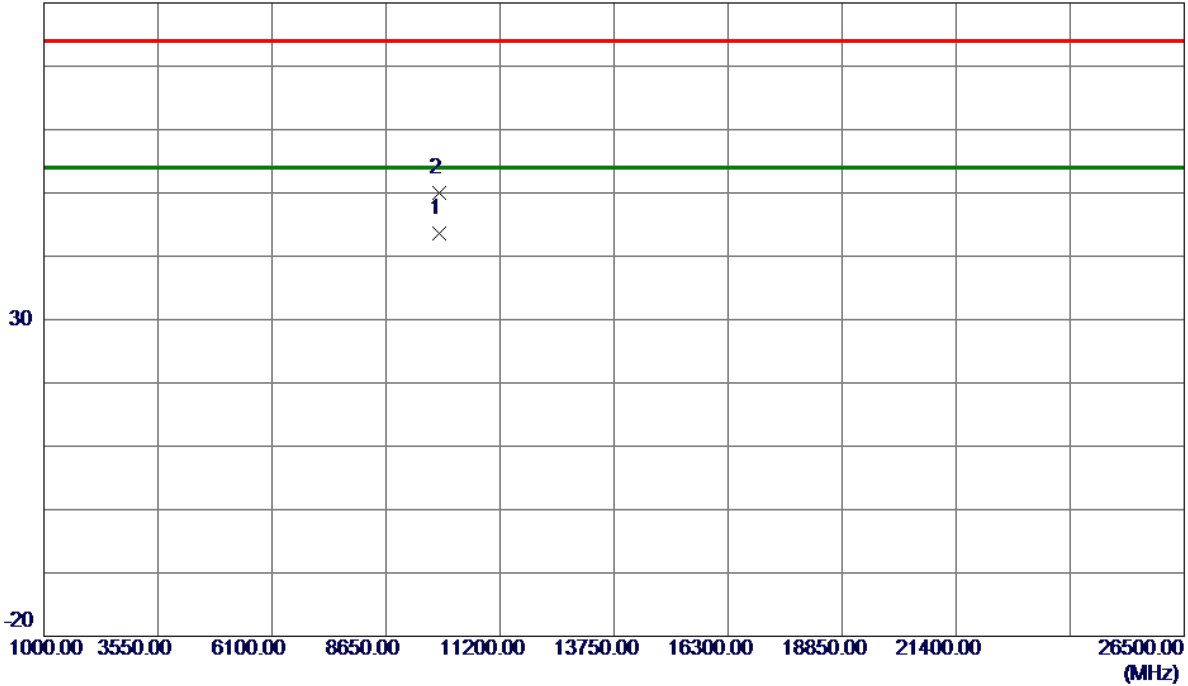

No.	Freq. MHz	Reading Level dBuV/m	Correct Factor dB	Measure ment dBuV/m	Limit dBuV/m	Margin dB	Detector	Comment
1 *	9848.1780	32.93	10.69	43.62	54.00	-10.38	AVG	
2	9848.3170	39.36	10.69	50.05	74.00	-23.95	Peak	

**REMARKS:**

- (1) Measurement Value = Reading Level + Correct Factor.
- (2) Margin Level = Measurement Value - Limit Value.

Orthogonal Axis	X
Test Mode:	TX G Mode 2462 MHz

**Horizontal**

130 dBuV/m

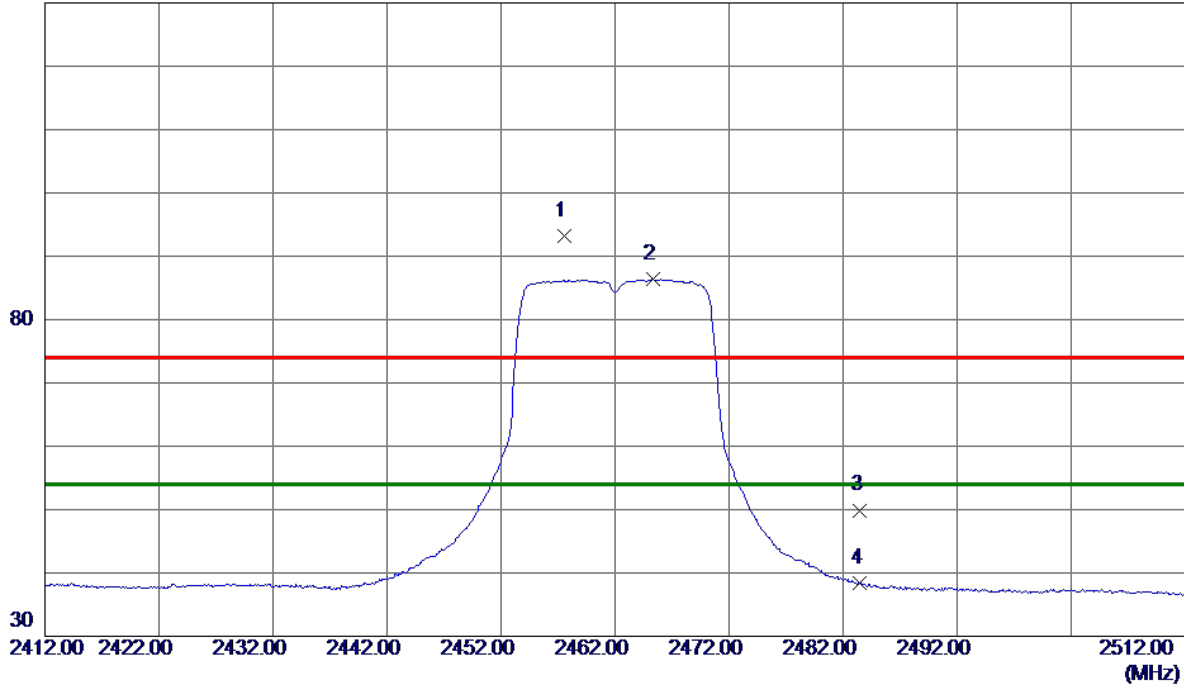

No.	Freq. MHz	Reading Level dBuV/m	Correct Factor dB	Measure ment dBuV/m	Limit dBuV/m	Margin dB	Detector	Comment
1	2457.6000	86.79	6.45	93.24	74.00	19.24	Peak	No Limit
2 *	2465.3000	79.92	6.44	86.36	54.00	32.36	AVG	No Limit
3	2483.5000	43.48	6.42	49.90	74.00	-24.10	Peak	
4	2483.5000	31.90	6.42	38.32	54.00	-15.68	AVG	

**REMARKS:**

- (1) Measurement Value = Reading Level + Correct Factor.
- (2) Margin Level = Measurement Value - Limit Value.

Orthogonal Axis	X
Test Mode:	TX G Mode 2462 MHz

**Horizontal**

80 dBuV/m

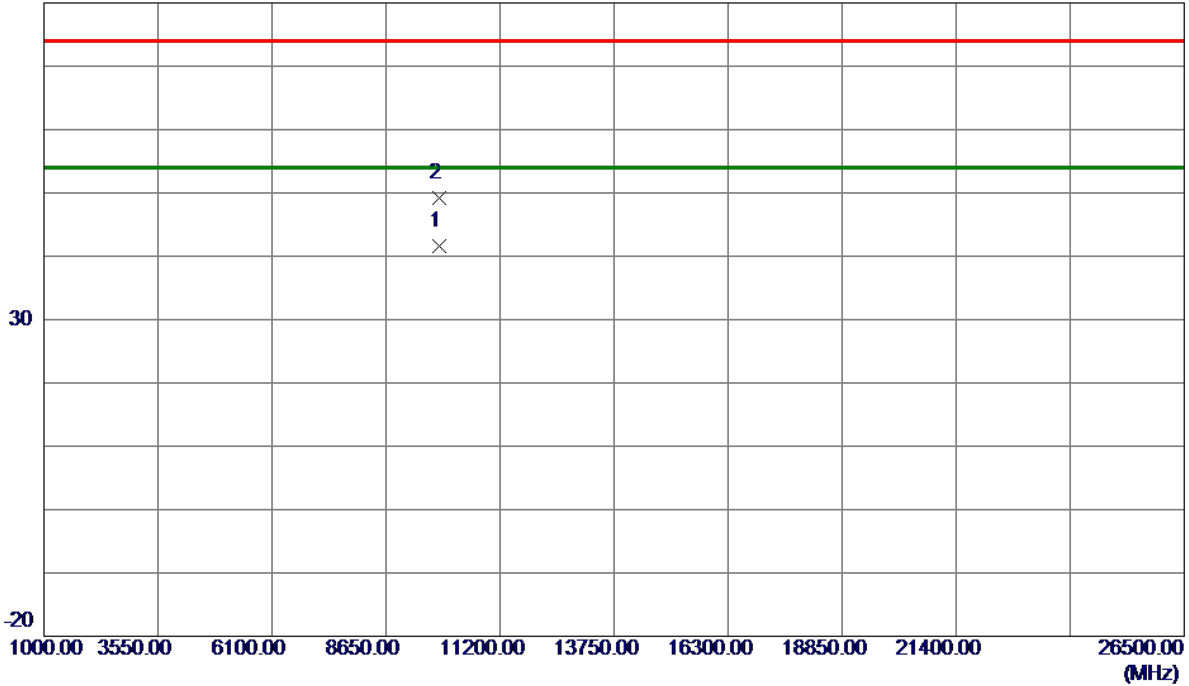

No.	Freq. MHz	Reading Level dBuV/m	Correct Factor dB	Measure ment dBuV/m	Limit dBuV/m	Margin dB	Detector	Comment
1 *	9848.0960	30.88	10.69	41.57	54.00	-12.43	AVG	
2	9848.1740	38.53	10.69	49.22	74.00	-24.78	Peak	

**REMARKS:**

- (1) Measurement Value = Reading Level + Correct Factor.
- (2) Margin Level = Measurement Value - Limit Value.

Orthogonal Axis	X
Test Mode:	TX N-20M Mode 2412 MHz

**Vertical**

130 dBuV/m

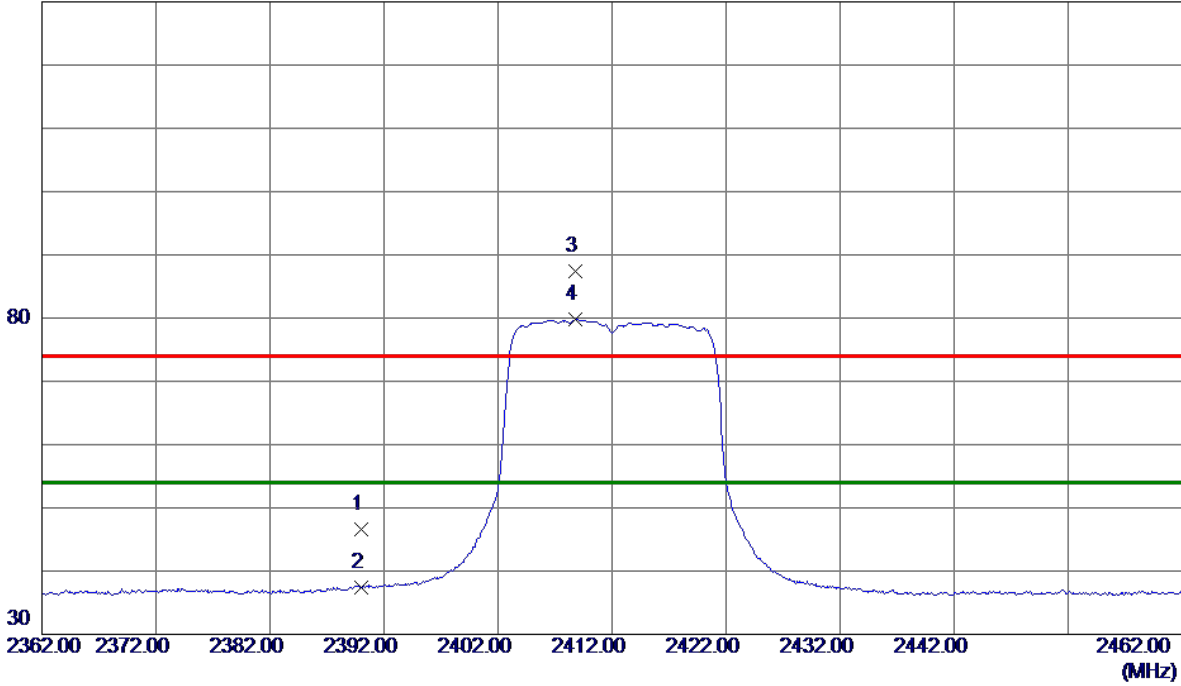

No.	Freq. MHz	Reading Level dBuV/m	Correct Factor dB	Measure ment dBuV/m	Limit dBuV/m	Margin dB	Detector	Comment
1	2390.0000	40.16	6.53	46.69	74.00	-27.31	Peak	
2	2390.0000	30.92	6.53	37.45	54.00	-16.55	AVG	
3	2408.8000	80.88	6.51	87.39	74.00	13.39	Peak	No Limit
4 *	2408.8000	73.24	6.51	79.75	54.00	25.75	AVG	No Limit

**REMARKS:**

- (1) Measurement Value = Reading Level + Correct Factor.
- (2) Margin Level = Measurement Value - Limit Value.

Orthogonal Axis	X
Test Mode:	TX N-20M Mode 2412 MHz

**Vertical**

80 dBuV/m

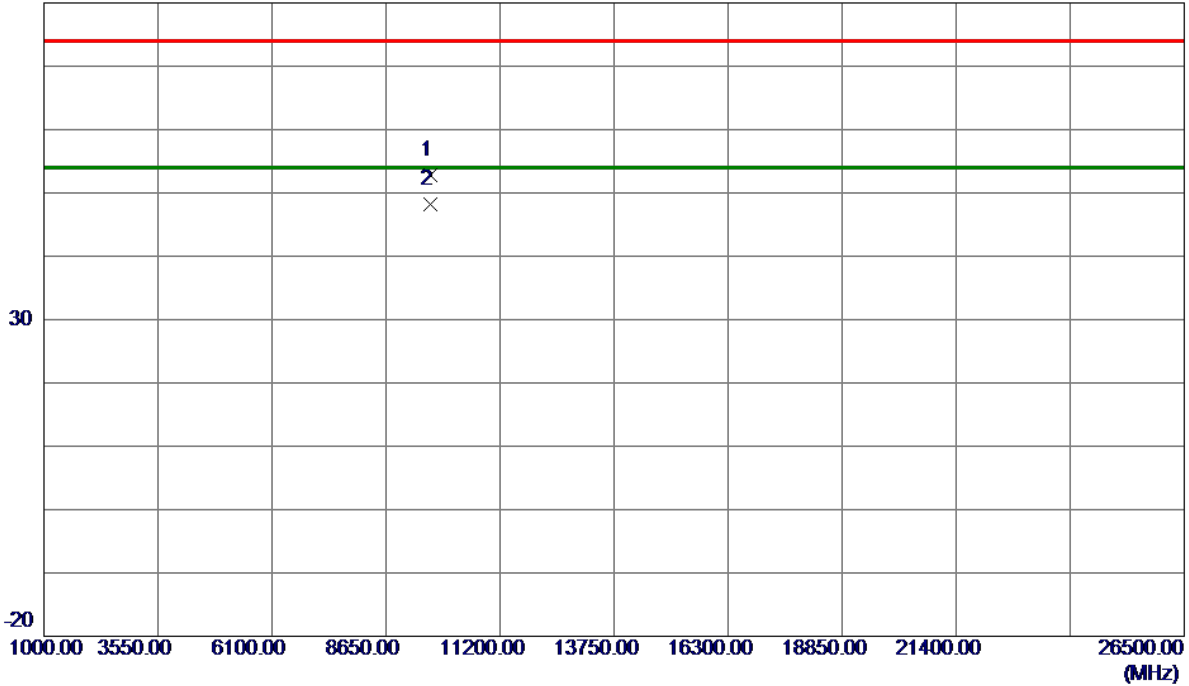

No.	Freq. MHz	Reading Level dBuV/m	Correct Factor dB	Measure ment dBuV/m	Limit dBuV/m	Margin dB	Detector	Comment
1	9647.9360	42.15	10.70	52.85	74.00	-21.15	Peak	
2 *	9648.1560	37.45	10.70	48.15	54.00	-5.85	AVG	

**REMARKS:**

- (1) Measurement Value = Reading Level + Correct Factor.
- (2) Margin Level = Measurement Value - Limit Value.

Orthogonal Axis	X
Test Mode:	TX N-20M Mode 2412 MHz

**Horizontal**

130 dBuV/m

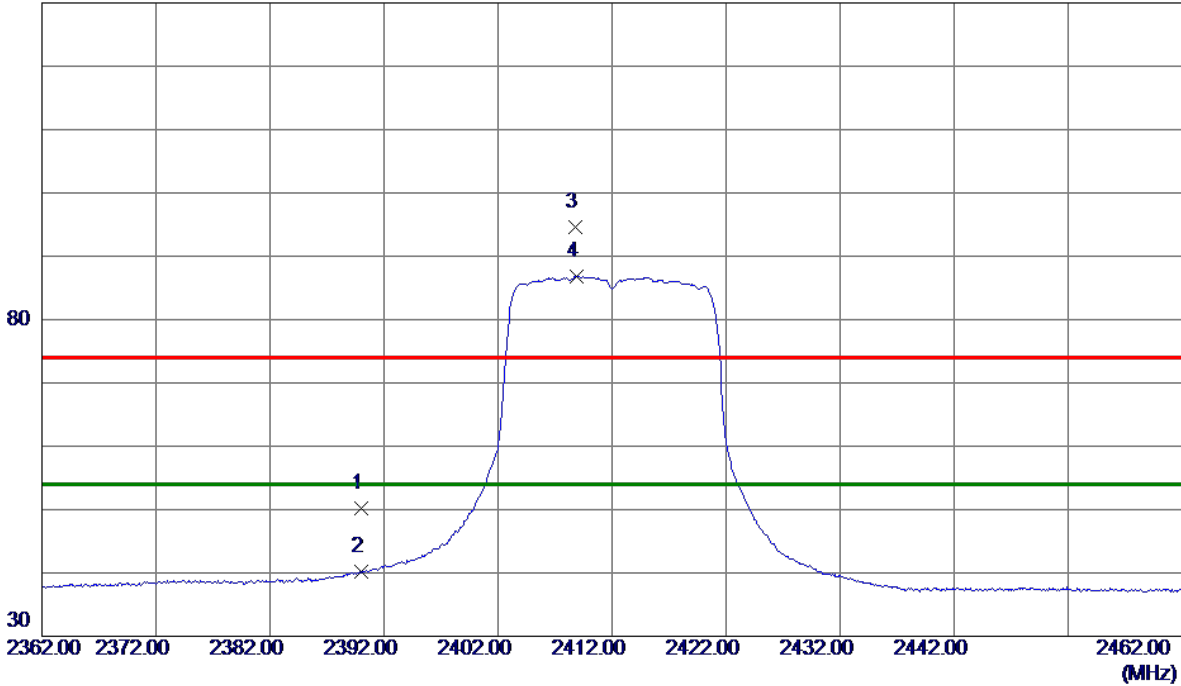

No.	Freq. MHz	Reading Level dBuV/m	Correct Factor dB	Measure ment dBuV/m	Limit dBuV/m	Margin dB	Detector	Comment
1	2390.0000	43.62	6.53	50.15	74.00	-23.85	Peak	
2	2390.0000	33.60	6.53	40.13	54.00	-13.87	AVG	
3	2408.8000	88.05	6.51	94.56	74.00	20.56	Peak	No Limit
4 *	2408.9000	80.35	6.51	86.86	54.00	32.86	AVG	No Limit

**REMARKS:**

- (1) Measurement Value = Reading Level + Correct Factor.
- (2) Margin Level = Measurement Value - Limit Value.

Orthogonal Axis	X
Test Mode:	TX N-20M Mode 2412 MHz

**Horizontal**

80 dBuV/m

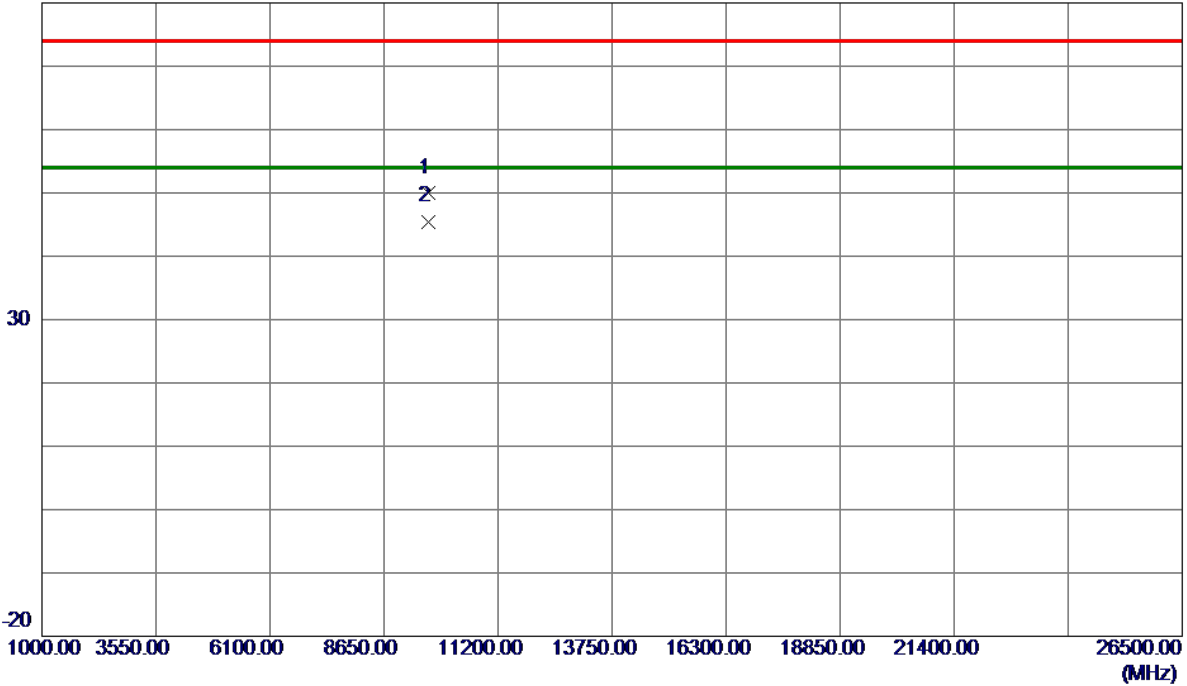

No.	Freq. MHz	Reading Level dBuV/m	Correct Factor dB	Measure ment dBuV/m	Limit dBuV/m	Margin dB	Detector	Comment
1	9648.1220	39.25	10.70	49.95	74.00	-24.05	Peak	
2 *	9648.1910	34.80	10.70	45.50	54.00	-8.50	AVG	

**REMARKS:**

- (1) Measurement Value = Reading Level + Correct Factor.
- (2) Margin Level = Measurement Value - Limit Value.



Orthogonal Axis	X
Test Mode:	TX N-20M Mode 2437 MHz

**Vertical**

130 dBuV/m

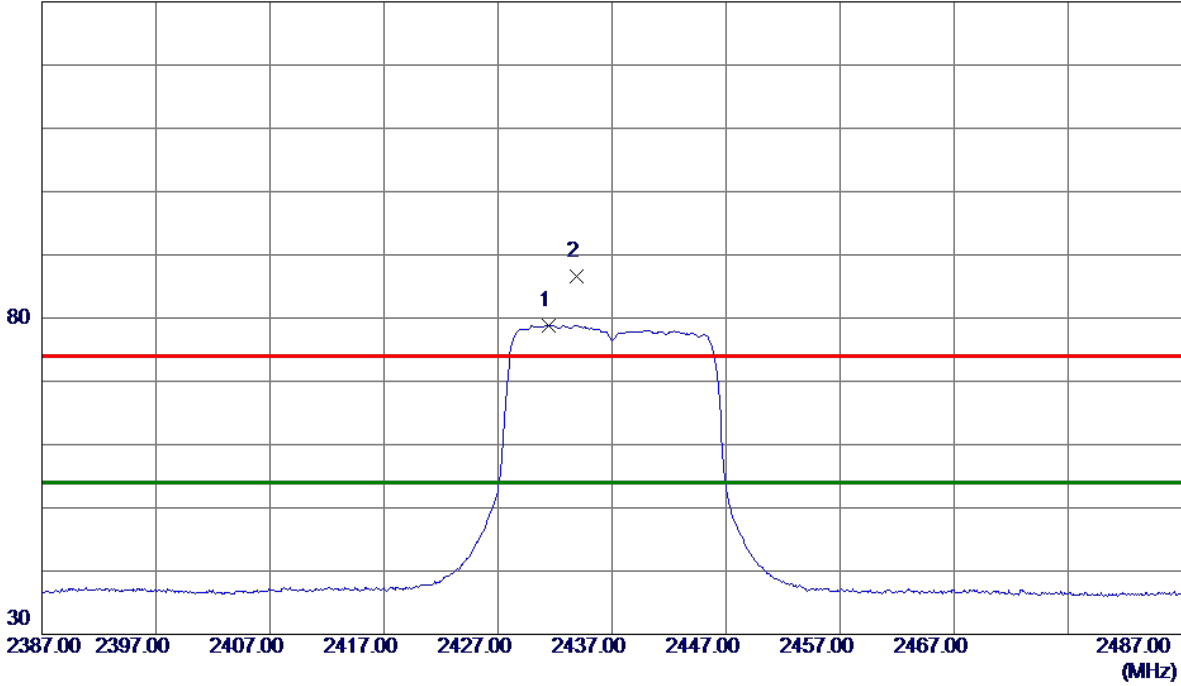

No.	Freq. MHz	Reading Level dBuV/m	Correct Factor dB	Measure ment dBuV/m	Limit dBuV/m	Margin dB	Detector	Comment
1 *	2431.4000	72.41	6.48	78.89	54.00	24.89	AVG	No Limit
2	2433.9000	80.15	6.48	86.63	74.00	12.63	Peak	No Limit

**REMARKS:**

- (1) Measurement Value = Reading Level + Correct Factor.
- (2) Margin Level = Measurement Value - Limit Value.

Orthogonal Axis	X
Test Mode:	TX N-20M Mode 2437 MHz

**Vertical**

80 dBuV/m

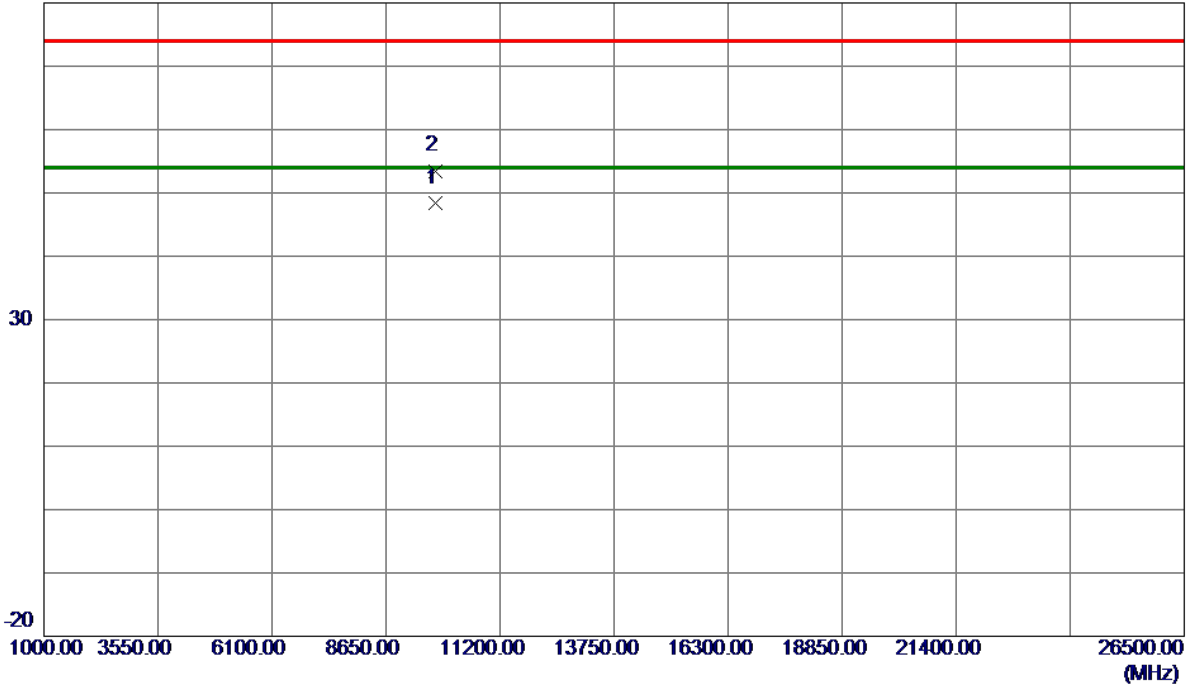

No.	Freq. MHz	Reading Level dBuV/m	Correct Factor dB	Measure ment dBuV/m	Limit dBuV/m	Margin dB	Detector	Comment
1 *	9748.1660	37.66	10.70	48.36	54.00	-5.64	AVG	
2	9748.1730	42.80	10.70	53.50	74.00	-20.50	Peak	

**REMARKS:**

- (1) Measurement Value = Reading Level + Correct Factor.
- (2) Margin Level = Measurement Value - Limit Value.

Orthogonal Axis	X
Test Mode:	TX N-20M Mode 2437 MHz

### Horizontal

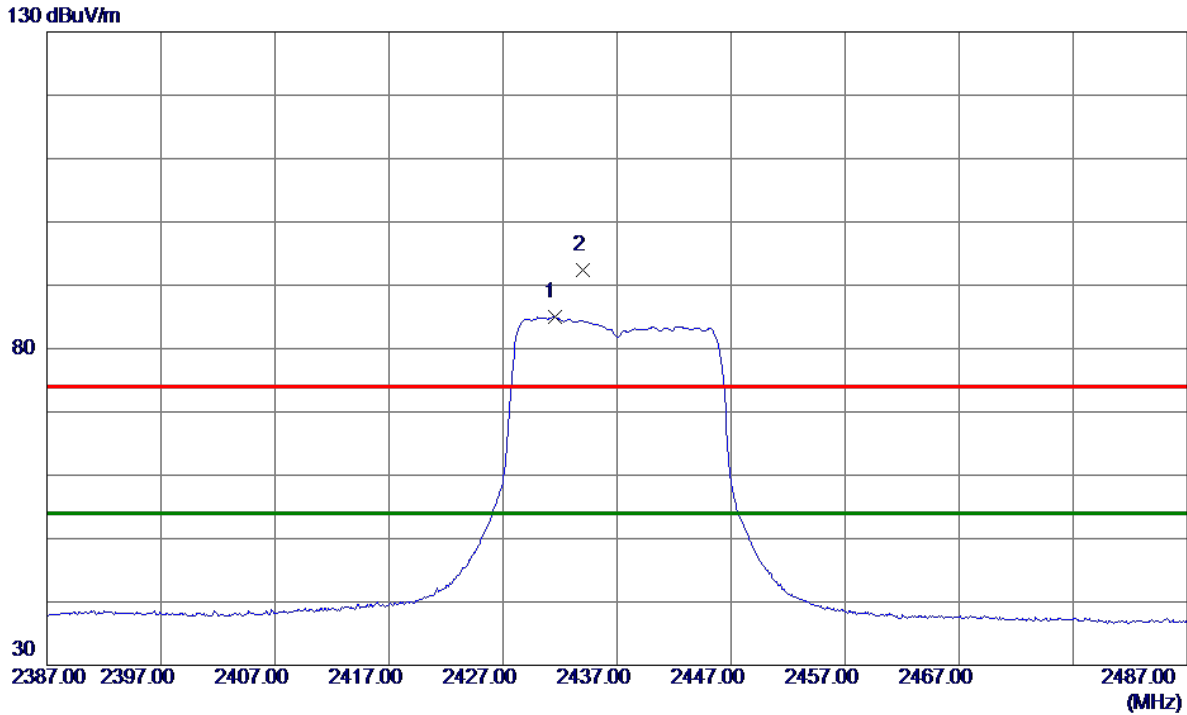

No.	Freq. MHz	Reading Level dBuV/m	Correct Factor dB	Measure ment dBuV/m	Limit dBuV/m	Margin dB	Detector	Comment
1 *	2431.5000	78.48	6.48	84.96	54.00	30.96	AVG	No Limit
2	2434.0500	85.93	6.48	92.41	74.00	18.41	Peak	No Limit

**REMARKS:**

- (1) Measurement Value = Reading Level + Correct Factor.
- (2) Margin Level = Measurement Value - Limit Value.

Orthogonal Axis	X
Test Mode:	TX N-20M Mode 2437 MHz

**Horizontal**

80 dBuV/m

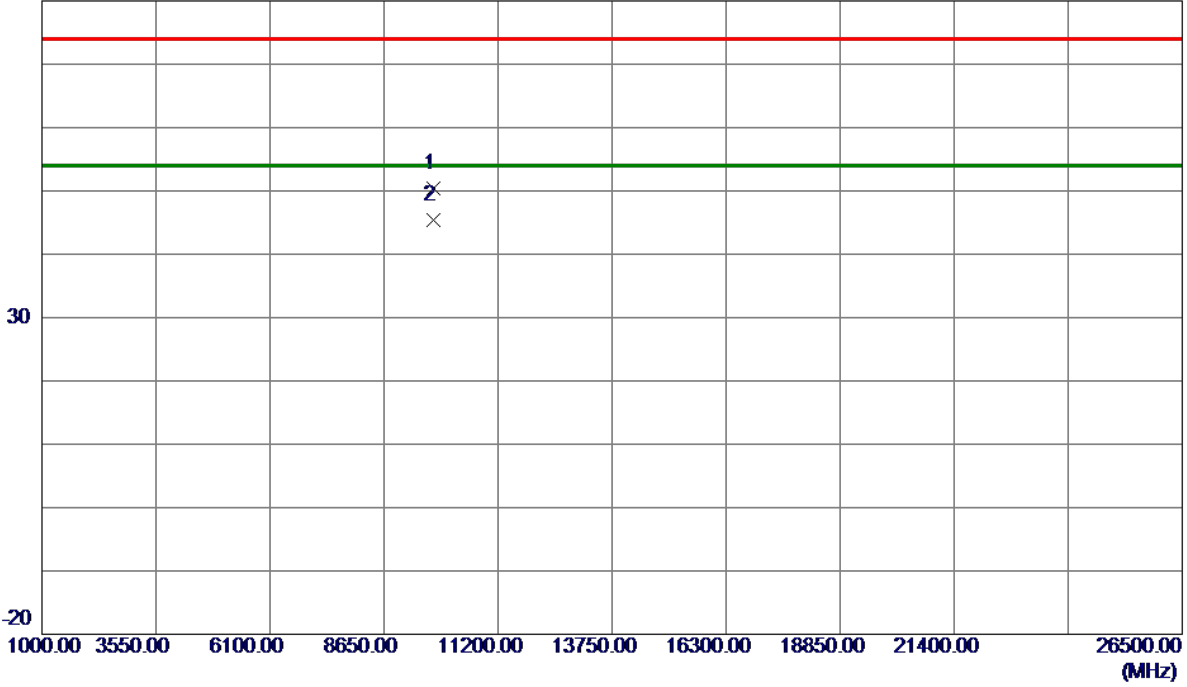

No.	Freq. MHz	Reading Level dBuV/m	Correct Factor dB	Measure ment dBuV/m	Limit dBuV/m	Margin dB	Detector	Comment
1	9748.1250	39.64	10.70	50.34	74.00	-23.66	Peak	
2 *	9748.1720	34.62	10.70	45.32	54.00	-8.68	AVG	

**REMARKS:**

- (1) Measurement Value = Reading Level + Correct Factor.
- (2) Margin Level = Measurement Value - Limit Value.

Orthogonal Axis	X
Test Mode:	TX N-20M Mode 2462 MHz

**Vertical**

130 dBuV/m

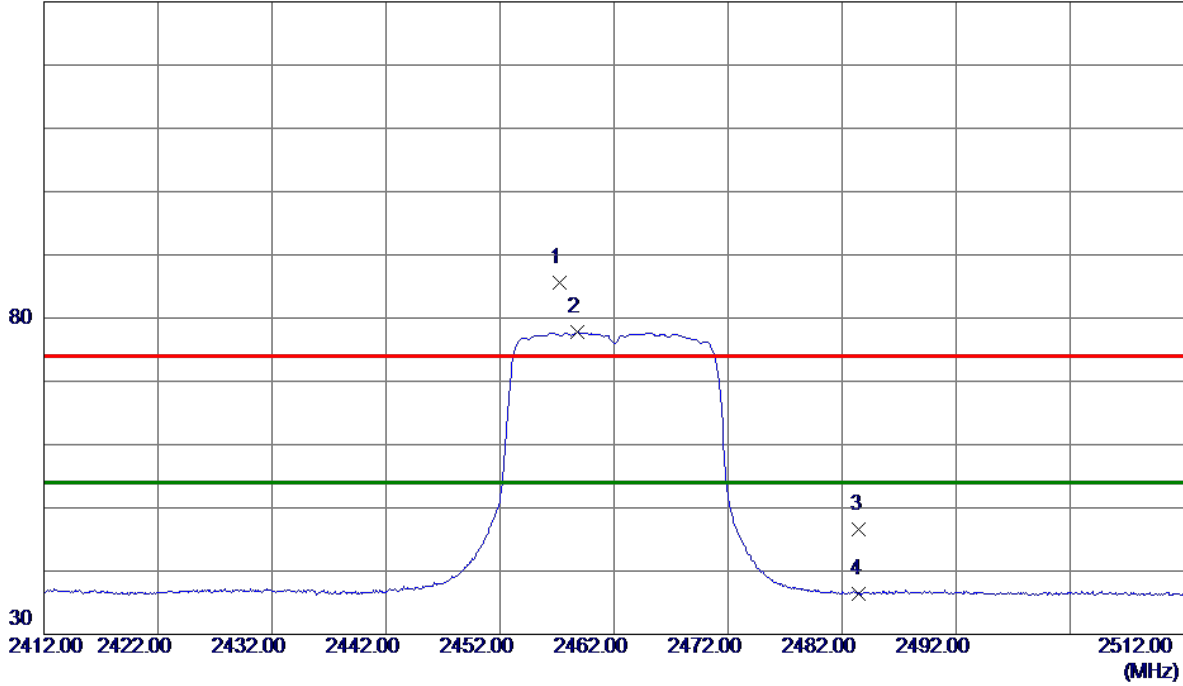

No.	Freq. MHz	Reading Level dBuV/m	Correct Factor dB	Measure ment dBuV/m	Limit dBuV/m	Margin dB	Detector	Comment
1	2457.2000	79.22	6.45	85.67	74.00	11.67	Peak	No Limit
2 *	2458.8000	71.32	6.45	77.77	54.00	23.77	AVG	No Limit
3	2483.5000	40.21	6.42	46.63	74.00	-27.37	Peak	
4	2483.5000	30.03	6.42	36.45	54.00	-17.55	AVG	

**REMARKS:**

- (1) Measurement Value = Reading Level + Correct Factor.
- (2) Margin Level = Measurement Value - Limit Value.

Orthogonal Axis	X
Test Mode:	TX N-20M Mode 2462 MHz

**Vertical**

80 dBuV/m

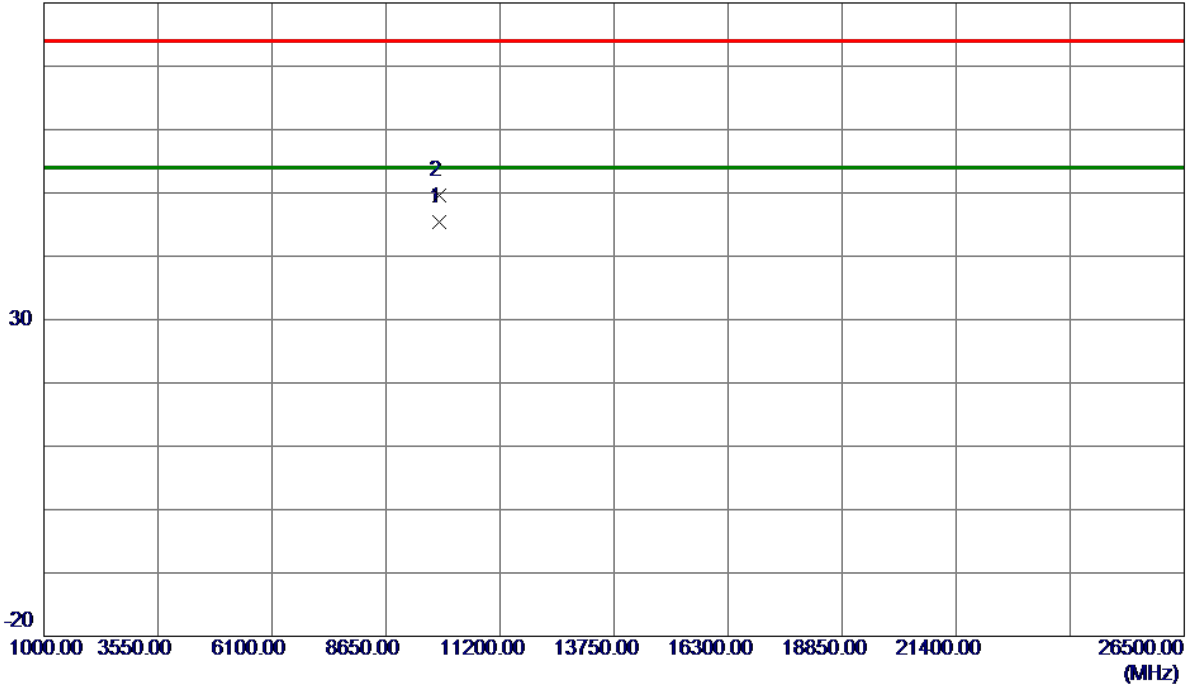

No.	Freq. MHz	Reading Level dBuV/m	Correct Factor dB	Measure ment dBuV/m	Limit dBuV/m	Margin dB	Detector	Comment
1 *	9848.0920	34.66	10.69	45.35	54.00	-8.65	AVG	
2	9848.2670	38.85	10.69	49.54	74.00	-24.46	Peak	

**REMARKS:**

- (1) Measurement Value = Reading Level + Correct Factor.
- (2) Margin Level = Measurement Value - Limit Value.

Orthogonal Axis	X
Test Mode:	TX N-20M Mode 2462 MHz

**Horizontal**

130 dBuV/m

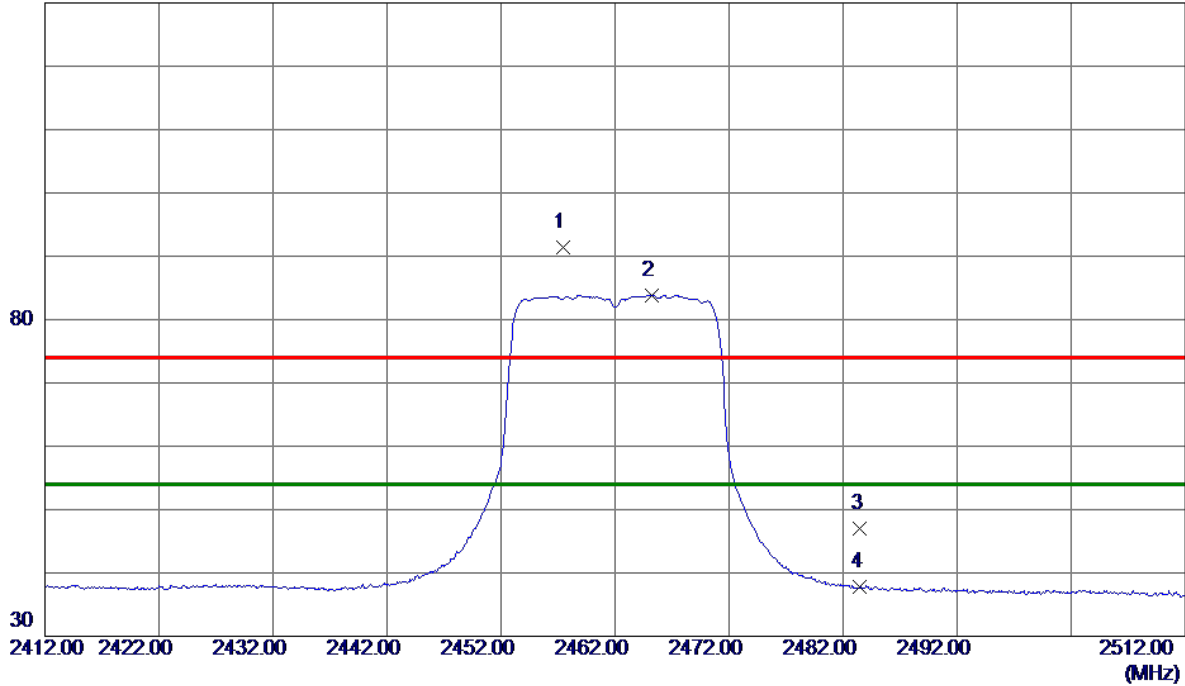

No.	Freq. MHz	Reading Level dBuV/m	Correct Factor dB	Measure ment dBuV/m	Limit dBuV/m	Margin dB	Detector	Comment
1	2457.4000	84.99	6.45	91.44	74.00	17.44	Peak	No Limit
2 *	2465.2500	77.39	6.44	83.83	54.00	29.83	AVG	No Limit
3	2483.5000	40.64	6.42	47.06	74.00	-26.94	Peak	
4	2483.5000	31.31	6.42	37.73	54.00	-16.27	AVG	

**REMARKS:**

- (1) Measurement Value = Reading Level + Correct Factor.
- (2) Margin Level = Measurement Value - Limit Value.

Orthogonal Axis	X
Test Mode:	TX N-20M Mode 2462 MHz

**Horizontal**

80 dBuV/m

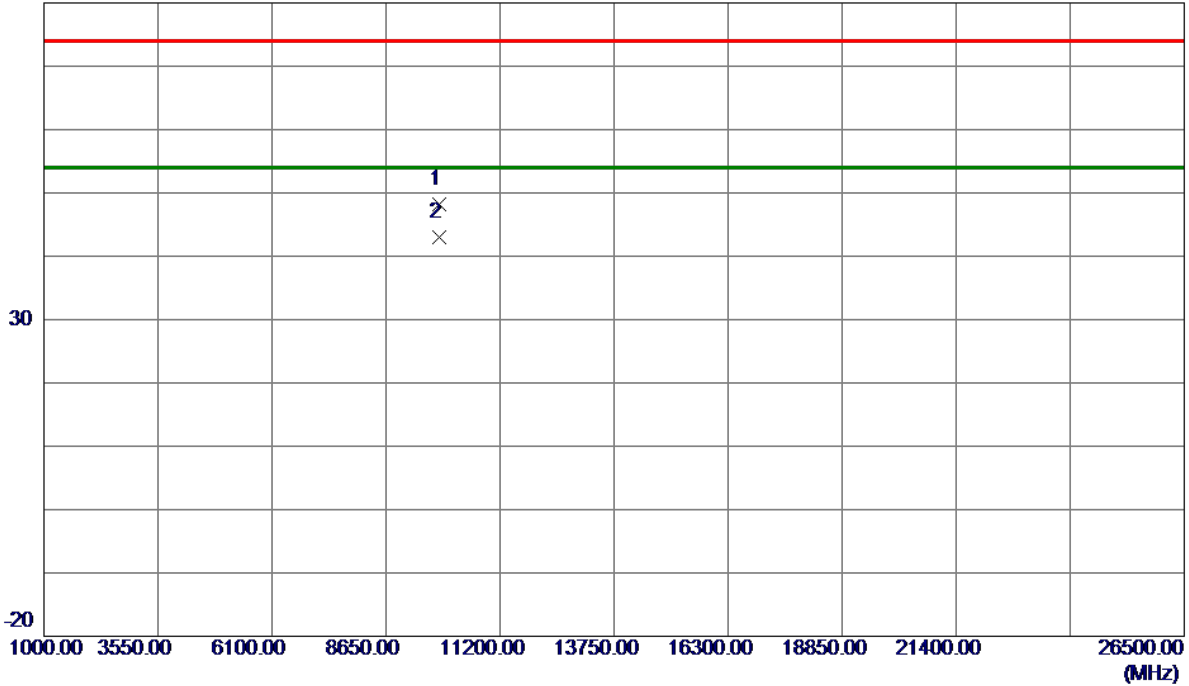

No.	Freq. MHz	Reading Level dBuV/m	Correct Factor dB	Measure ment dBuV/m	Limit dBuV/m	Margin dB	Detector	Comment
1	9848.1490	37.59	10.69	48.28	74.00	-25.72	Peak	
2 *	9848.2070	32.25	10.69	42.94	54.00	-11.06	AVG	

**REMARKS:**

- (1) Measurement Value = Reading Level + Correct Factor.
- (2) Margin Level = Measurement Value - Limit Value.



Orthogonal Axis	X
Test Mode:	TX N-40M Mode 2422MHz

**Vertical**

130 dBuV/m

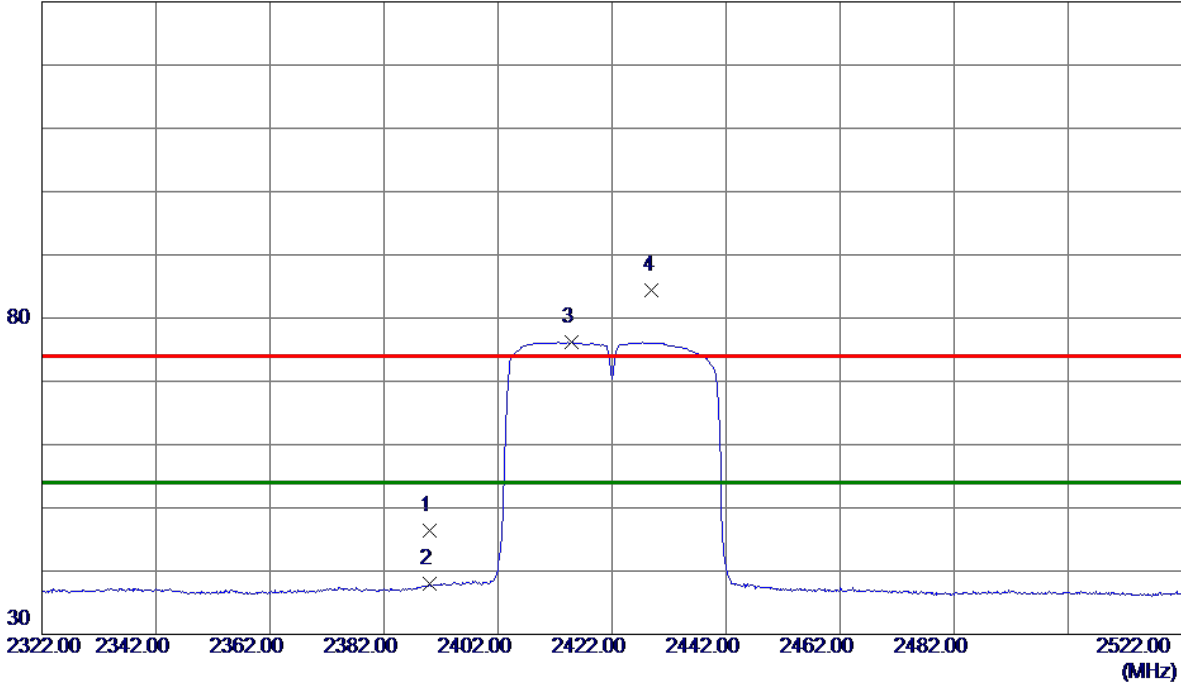

No.	Freq. MHz	Reading Level dBuV/m	Correct Factor dB	Measure ment dBuV/m	Limit dBuV/m	Margin dB	Detector	Comment
1	2390.0000	39.83	6.53	46.36	74.00	-27.64	Peak	
2	2390.0000	31.43	6.53	37.96	54.00	-16.04	AVG	
3 *	2414.9000	69.66	6.50	76.16	54.00	22.16	AVG	No Limit
4	2429.0000	77.98	6.49	84.47	74.00	10.47	Peak	No Limit

**REMARKS:**

- (1) Measurement Value = Reading Level + Correct Factor.
- (2) Margin Level = Measurement Value - Limit Value.

Orthogonal Axis	X
Test Mode:	TX N-40M Mode 2422MHz

**Vertical**

80 dBuV/m

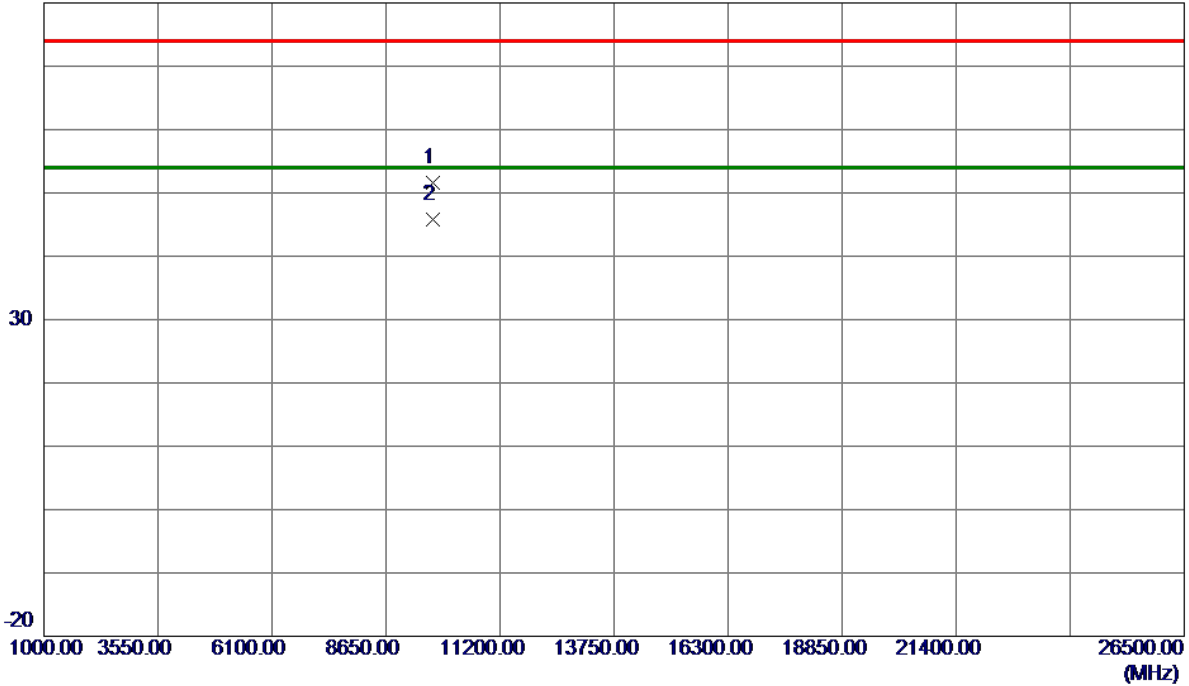

No.	Freq. MHz	Reading Level dBuV/m	Correct Factor dB	Measure ment dBuV/m	Limit dBuV/m	Margin dB	Detector	Comment
1	9687.9650	40.92	10.70	51.62	74.00	-22.38	Peak	
2 *	9688.1300	35.06	10.70	45.76	54.00	-8.24	AVG	

**REMARKS:**

- (1) Measurement Value = Reading Level + Correct Factor.
- (2) Margin Level = Measurement Value - Limit Value.

Orthogonal Axis	X
Test Mode:	TX N-40M Mode 2422MHz

**Horizontal**

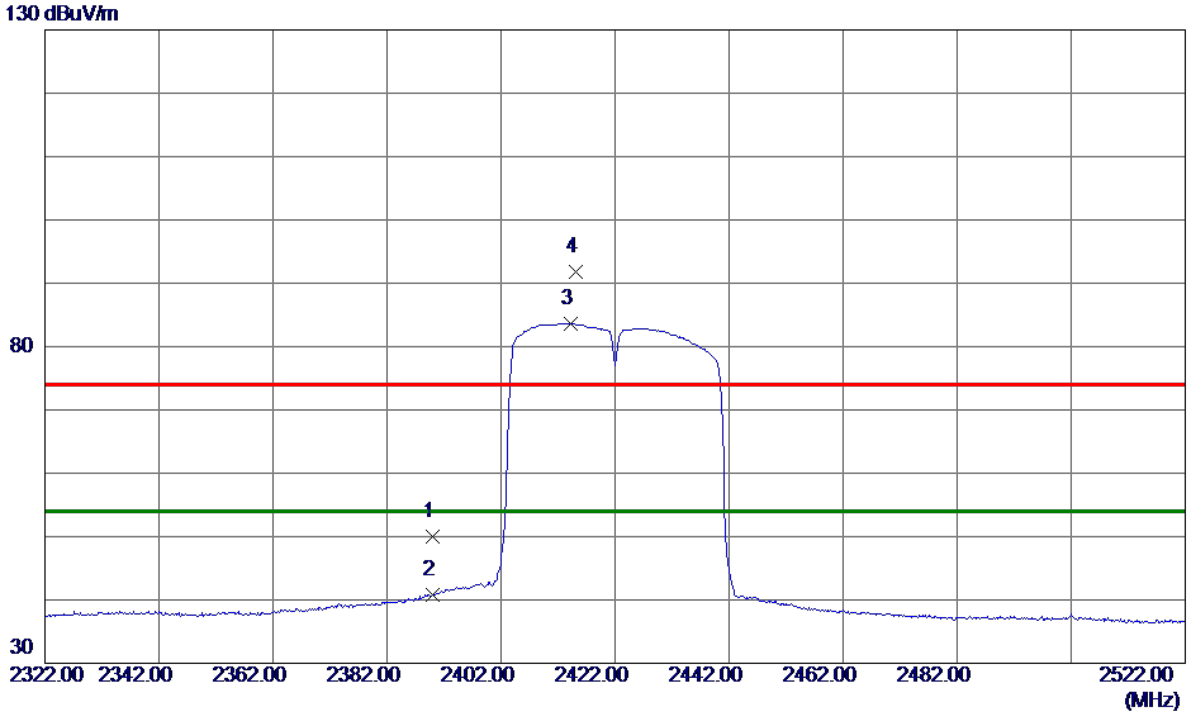

No.	Freq. MHz	Reading Level dBuV/m	Correct Factor dB	Measure ment dBuV/m	Limit dBuV/m	Margin dB	Detector	Comment
1	2390.0000	43.40	6.53	49.93	74.00	-24.07	Peak	
2	2390.0000	34.18	6.53	40.71	54.00	-13.29	AVG	
3 *	2414.2000	77.11	6.50	83.61	54.00	29.61	AVG	No Limit
4	2415.2000	85.34	6.50	91.84	74.00	17.84	Peak	No Limit

**REMARKS:**

- (1) Measurement Value = Reading Level + Correct Factor.
- (2) Margin Level = Measurement Value - Limit Value.

Orthogonal Axis	X
Test Mode:	TX N-40M Mode 2422MHz

**Horizontal**

80 dBuV/m

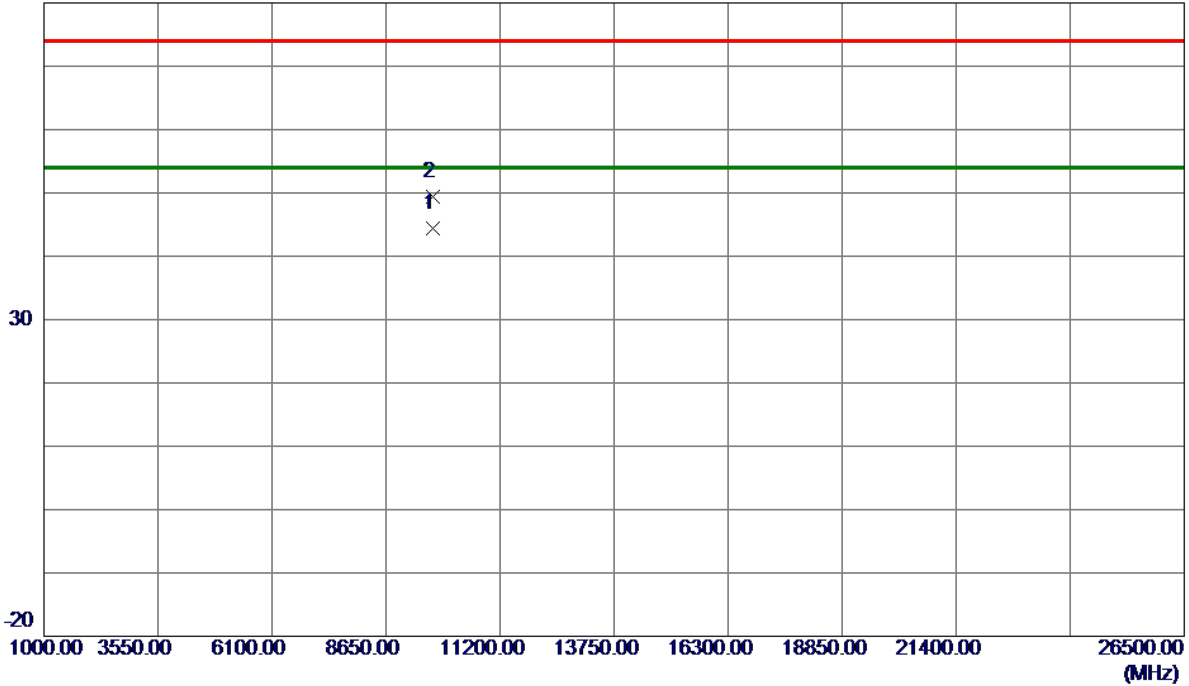

No.	Freq. MHz	Reading Level dBuV/m	Correct Factor dB	Measure ment dBuV/m	Limit dBuV/m	Margin dB	Detector	Comment
1 *	9688.1760	33.74	10.70	44.44	54.00	-9.56	AVG	
2	9688.2440	38.65	10.70	49.35	74.00	-24.65	Peak	

**REMARKS:**

- (1) Measurement Value = Reading Level + Correct Factor.
- (2) Margin Level = Measurement Value - Limit Value.

Orthogonal Axis	X
Test Mode:	TX N-40M Mode 2437 MHz

**Vertical**

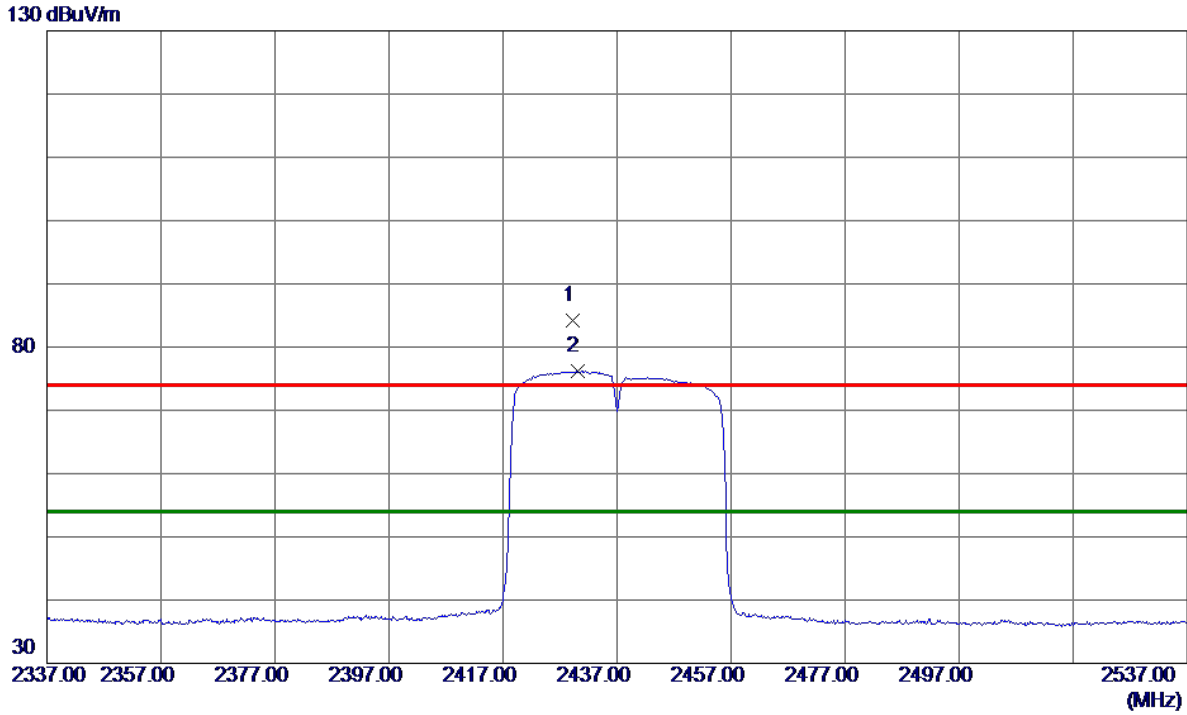

No.	Freq. MHz	Reading Level dBuV/m	Correct Factor dB	Measure ment dBuV/m	Limit dBuV/m	Margin dB	Detector	Comment
1	2429.3000	77.70	6.49	84.19	74.00	10.19	Peak	No Limit
2 *	2430.0000	69.73	6.49	76.22	54.00	22.22	AVG	No Limit

**REMARKS:**

- (1) Measurement Value = Reading Level + Correct Factor.
- (2) Margin Level = Measurement Value - Limit Value.

Orthogonal Axis	X
Test Mode:	TX N-40M Mode 2437 MHz

**Vertical**

80 dBuV/m

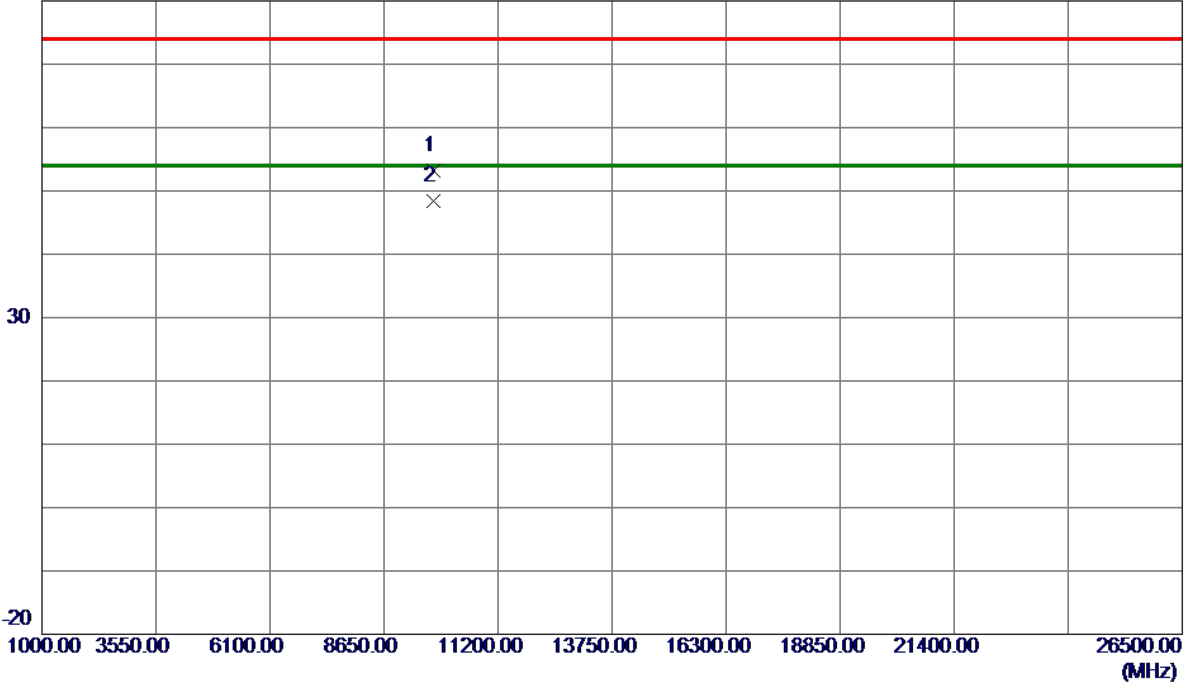

No.	Freq. MHz	Reading Level dBuV/m	Correct Factor dB	Measure ment dBuV/m	Limit dBuV/m	Margin dB	Detector	Comment
1	9748.0340	42.53	10.70	53.23	74.00	-20.77	Peak	
2 *	9748.1830	37.67	10.70	48.37	54.00	-5.63	AVG	

**REMARKS:**

- (1) Measurement Value = Reading Level + Correct Factor.
- (2) Margin Level = Measurement Value - Limit Value.

Orthogonal Axis	X
Test Mode:	TX N-40M Mode 2437 MHz

**Horizontal**

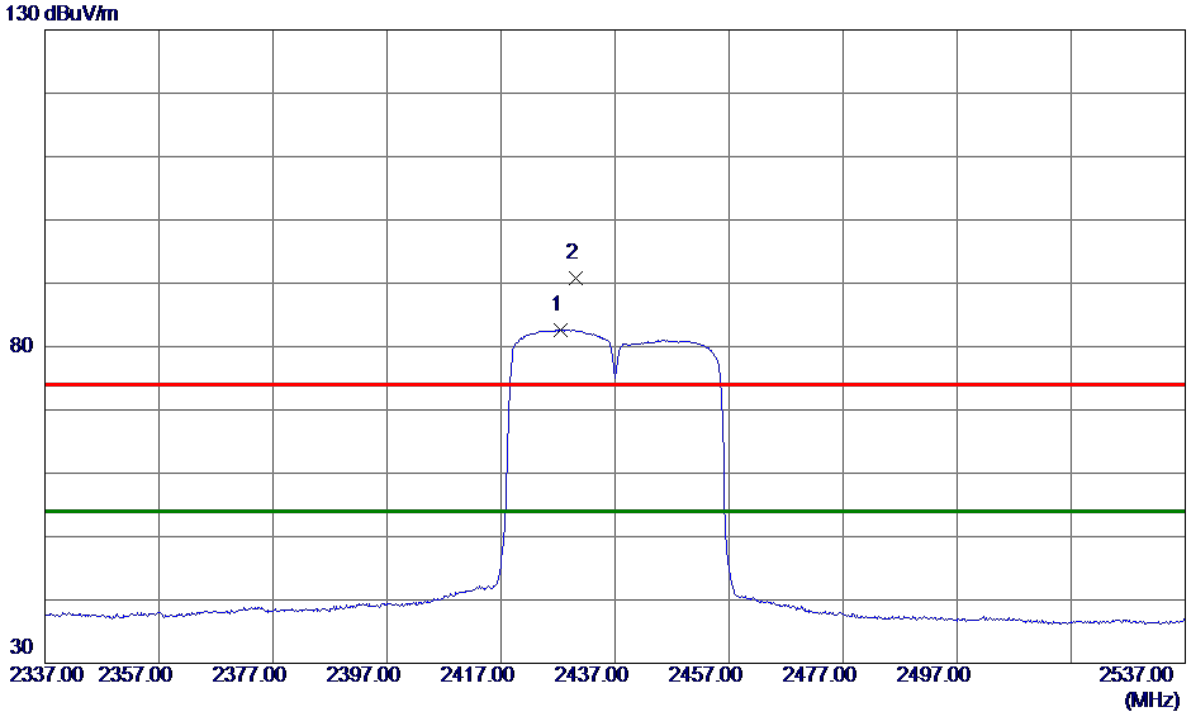

No.	Freq. MHz	Reading Level dBuV/m	Correct Factor dB	Measure ment dBuV/m	Limit dBuV/m	Margin dB	Detector	Comment
1 *	2427.5000	76.12	6.49	82.61	54.00	28.61	AVG	No Limit
2	2430.2000	84.39	6.49	90.88	74.00	16.88	Peak	No Limit

**REMARKS:**

- (1) Measurement Value = Reading Level + Correct Factor.
- (2) Margin Level = Measurement Value - Limit Value.

Orthogonal Axis	X
Test Mode:	TX N-40M Mode 2437 MHz

**Horizontal**

80 dBuV/m

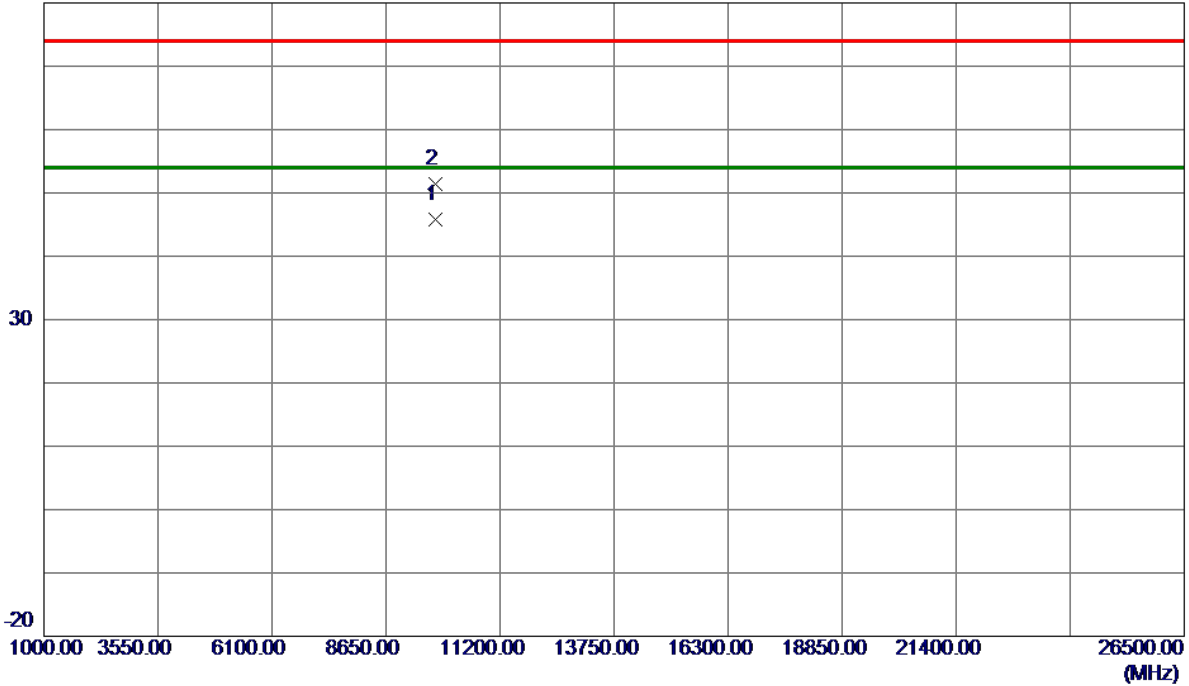

No.	Freq. MHz	Reading Level dBuV/m	Correct Factor dB	Measure ment dBuV/m	Limit dBuV/m	Margin dB	Detector	Comment
1 *	9748.1470	35.12	10.70	45.82	54.00	-8.18	AVG	
2	9748.1910	40.74	10.70	51.44	74.00	-22.56	Peak	

**REMARKS:**

- (1) Measurement Value = Reading Level + Correct Factor.
- (2) Margin Level = Measurement Value - Limit Value.



Orthogonal Axis	X
Test Mode:	TX N-40M Mode 2452 MHz

**Vertical**

130 dBuV/m

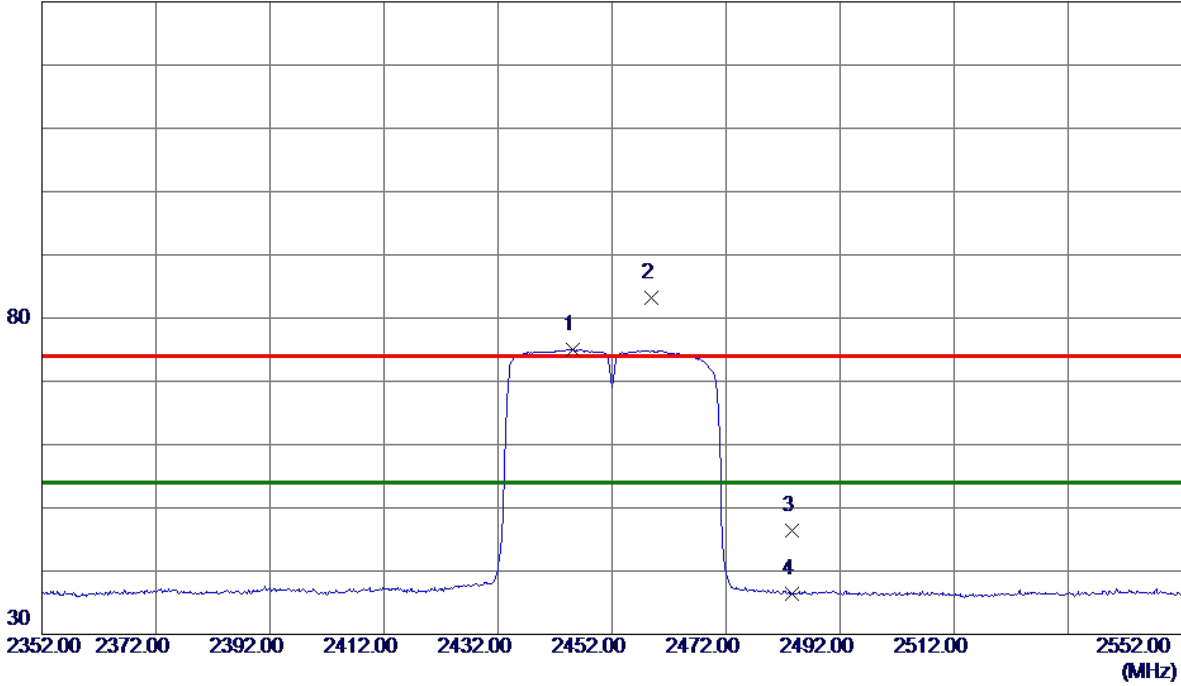

No.	Freq. MHz	Reading Level dBuV/m	Correct Factor dB	Measure ment dBuV/m	Limit dBuV/m	Margin dB	Detector	Comment
1 *	2445.1000	68.58	6.47	75.05	54.00	21.05	AVG	No Limit
2	2458.8000	76.76	6.45	83.21	74.00	9.21	Peak	No Limit
3	2483.5000	39.99	6.42	46.41	74.00	-27.59	Peak	
4	2483.5000	30.05	6.42	36.47	54.00	-17.53	AVG	

**REMARKS:**

- (1) Measurement Value = Reading Level + Correct Factor.
- (2) Margin Level = Measurement Value - Limit Value.

Orthogonal Axis	X
Test Mode:	TX N-40M Mode 2452 MHz

**Vertical**

80 dBuV/m

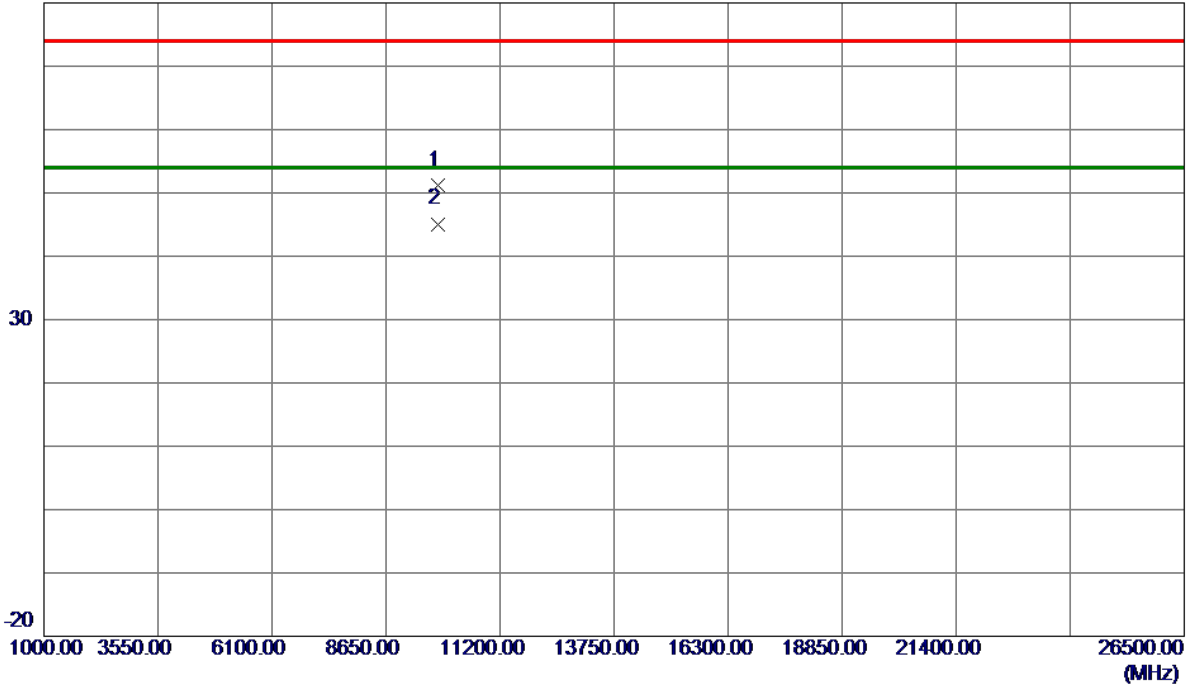

No.	Freq. MHz	Reading Level dBuV/m	Correct Factor dB	Measure ment dBuV/m	Limit dBuV/m	Margin dB	Detector	Comment
1	9808.1520	40.54	10.70	51.24	74.00	-22.76	Peak	
2 *	9808.1540	34.40	10.70	45.10	54.00	-8.90	AVG	

**REMARKS:**

- (1) Measurement Value = Reading Level + Correct Factor.
- (2) Margin Level = Measurement Value - Limit Value.

Orthogonal Axis	X
Test Mode:	TX N-40M Mode 2452 MHz

**Horizontal**

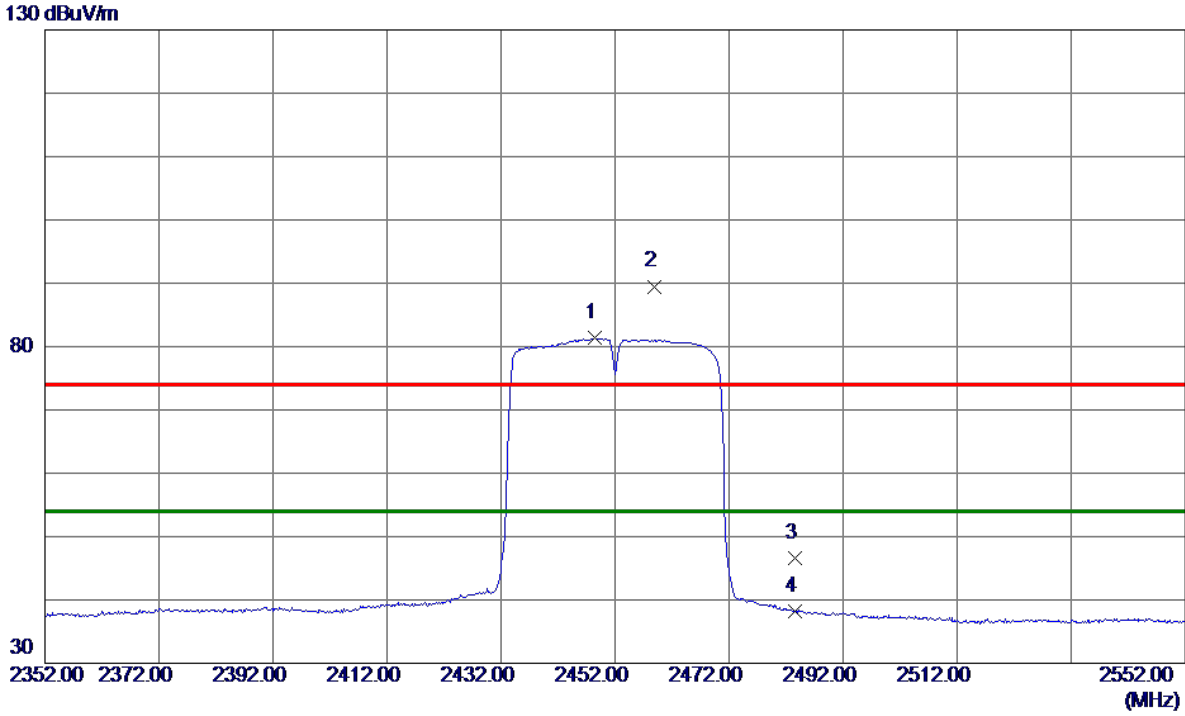

No.	Freq. MHz	Reading Level dBuV/m	Correct Factor dB	Measure ment dBuV/m	Limit dBuV/m	Margin dB	Detector	Comment
1 *	2448.5000	74.91	6.46	81.37	54.00	27.37	AVG	No Limit
2	2458.9000	83.05	6.45	89.50	74.00	15.50	Peak	No Limit
3	2483.5000	40.17	6.42	46.59	74.00	-27.41	Peak	
4	2483.5000	31.73	6.42	38.15	54.00	-15.85	AVG	

**REMARKS:**

- (1) Measurement Value = Reading Level + Correct Factor.
- (2) Margin Level = Measurement Value - Limit Value.

Orthogonal Axis	X
Test Mode:	TX N-40M Mode 2452 MHz

**Horizontal**

80 dBuV/m

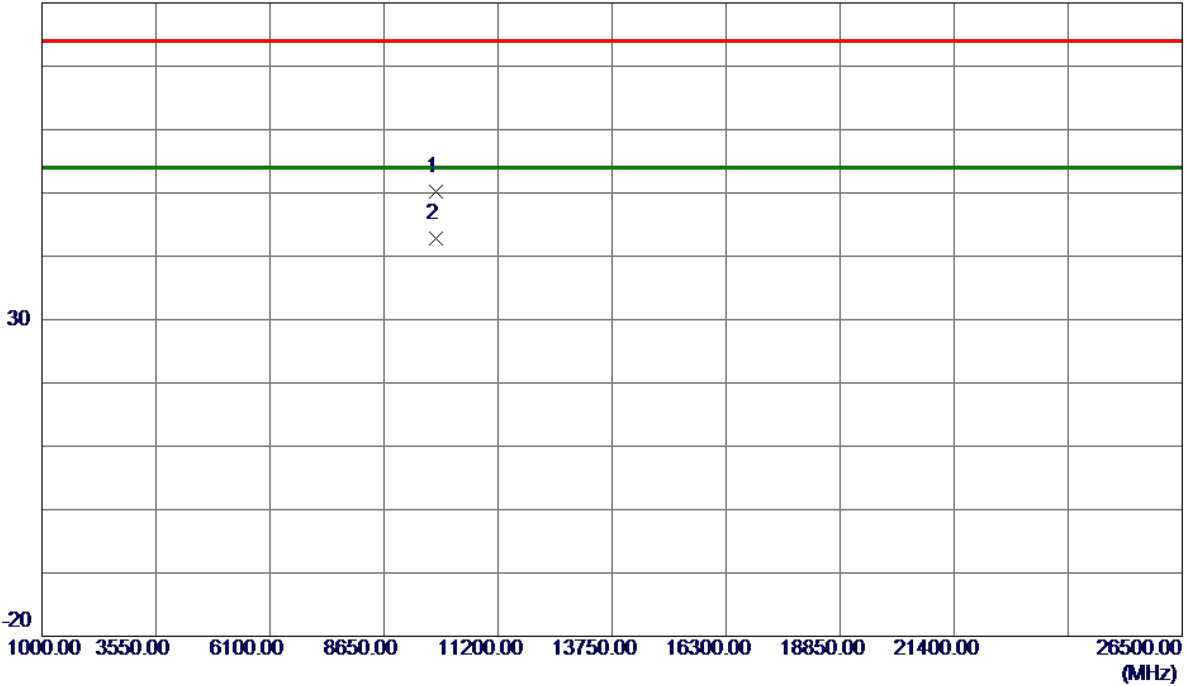

No.	Freq. MHz	Reading Level dBuV/m	Correct Factor dB	Measure ment dBuV/m	Limit dBuV/m	Margin dB	Detector	Comment
1	9808.1449	39.49	10.70	50.19	74.00	-23.81	Peak	
2 *	9808.1810	32.16	10.70	42.86	54.00	-11.14	AVG	

**REMARKS:**

- (1) Measurement Value = Reading Level + Correct Factor.
- (2) Margin Level = Measurement Value - Limit Value.

## APPENDIX E - BANDWIDTH

Test Mode	TX B Mode
-----------	-----------

Channel	Frequency (MHz)	6 dB Bandwidth (MHz)	99 % Emission Bandwidth (MHz)	6 dB Bandwidth Min. Limit (kHz)	Result
01	2412	10.11	14.92	500	Complies
06	2437	10.10	14.84	500	Complies
11	2462	10.11	14.88	500	Complies

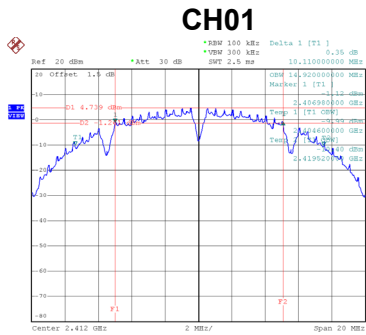

Date: 7.MAY.2019 11:16:46

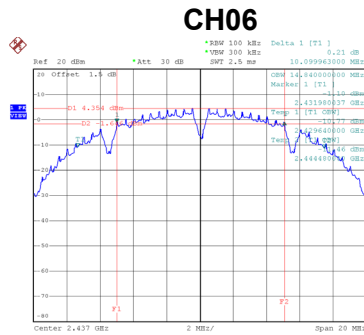

Date: 7.MAY.2019 11:18:21

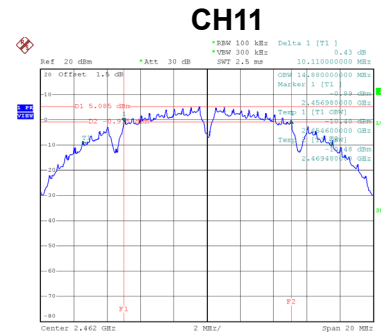

Date: 7.MAY.2019 11:20:23

Test Mode	TX G Mode
-----------	-----------

Channel	Frequency (MHz)	6 dB Bandwidth (MHz)	99 % Emission Bandwidth (MHz)	6 dB Bandwidth Min. Limit (kHz)	Result
01	2412	16.44	16.52	500	Complies
06	2437	16.38	16.52	500	Complies
11	2462	16.42	16.52	500	Complies

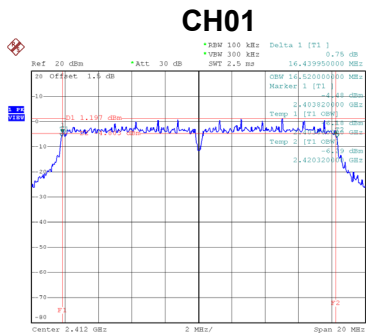

Date: 7.MAY.2019 11:23:09

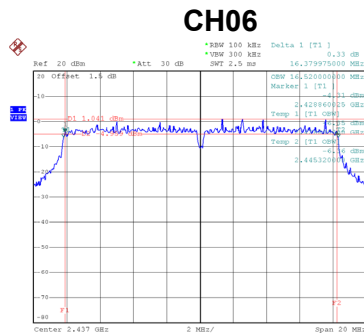

Date: 7.MAY.2019 11:24:56

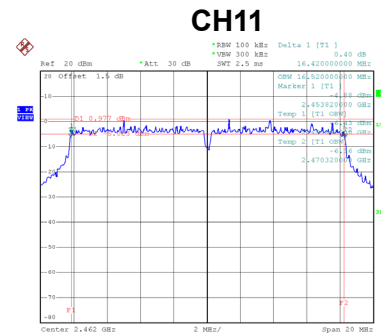

Date: 7.MAY.2019 11:27:43

Test Mode	TX N-20M Mode
-----------	---------------

Channel	Frequency (MHz)	6 dB Bandwidth (MHz)	99 % Emission Bandwidth (MHz)	6 dB Bandwidth Min. Limit (kHz)	Result
01	2412	17.62	17.68	500	Complies
06	2437	17.58	17.68	500	Complies
11	2462	17.58	17.60	500	Complies

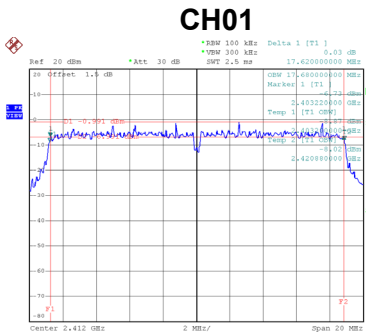

Date: 7.MAY.2019 11:31:57

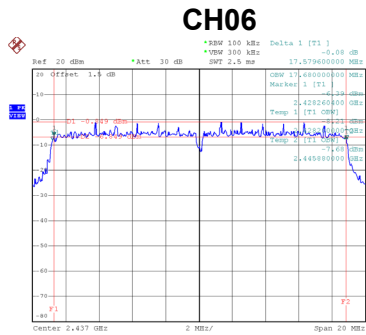

Date: 7.MAY.2019 11:35:52

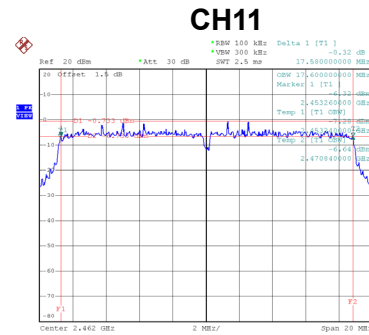

Date: 7.MAY.2019 11:43:43

Test Mode	TX N-40M Mode
-----------	---------------

Channel	Frequency (MHz)	6 dB Bandwidth (MHz)	99 % Emission Bandwidth (MHz)	6 dB Bandwidth Min. Limit (kHz)	Result
03	2422	34.76	35.92	500	Complies
06	2437	35.27	35.84	500	Complies
09	2452	35.28	35.84	500	Complies

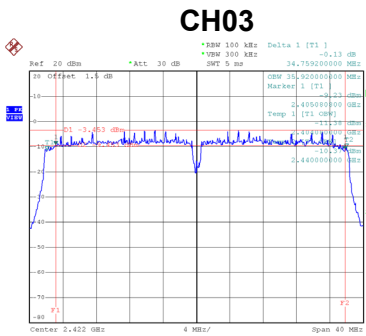

Date: 7.MAY.2019 11:46:34

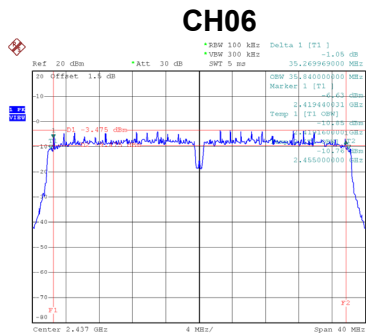

Date: 7.MAY.2019 11:49:06

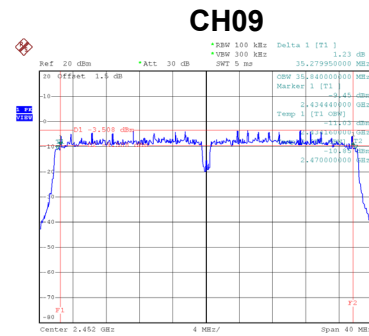

Date: 7.MAY.2019 11:51:34

## APPENDIX F - MAXIMUM OUTPUT POWER



Test Mode	TX B Mode
-----------	-----------

Channel	Frequency (MHz)	Output Power (dBm)	Output Power (W)	Max. Limit (dBm)	Max. Limit (W)	Result
01	2412	15.88	0.0387	30.00	1.0000	Complies
06	2437	15.96	0.0394	30.00	1.0000	Complies
11	2462	16.02	0.0400	30.00	1.0000	Complies

Test Mode	TX G Mode
-----------	-----------

Channel	Frequency (MHz)	Output Power (dBm)	Output Power (W)	Max. Limit (dBm)	Max. Limit (W)	Result
01	2412	14.21	0.0264	30.00	1.0000	Complies
06	2437	14.34	0.0272	30.00	1.0000	Complies
11	2462	14.43	0.0278	30.00	1.0000	Complies

Test Mode	TX N-20M Mode
-----------	---------------

Channel	Frequency (MHz)	Output Power (dBm)	Output Power (W)	Max. Limit (dBm)	Max. Limit (W)	Result
01	2412	12.24	0.0167	30.00	1.0000	Complies
06	2437	12.45	0.0176	30.00	1.0000	Complies
11	2462	12.48	0.0177	30.00	1.0000	Complies

Test Mode	TX N-40M Mode
-----------	---------------

Channel	Frequency (MHz)	Output Power (dBm)	Output Power (W)	Max. Limit (dBm)	Max. Limit (W)	Result
03	2422	12.42	0.0175	30.00	1.0000	Complies
06	2437	12.51	0.0178	30.00	1.0000	Complies
09	2452	12.53	0.0179	30.00	1.0000	Complies

## APPENDIX G - CONDUCTED SPURIOUS EMISSIONS

Test Mode TX B Mode

### Bandedge-CH01

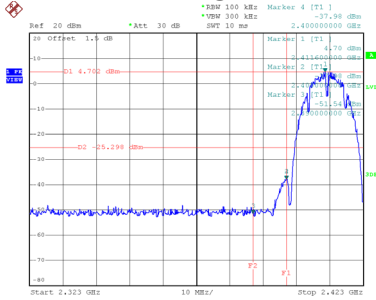

Date: 7.MAY.2019 11:16:18

### Bandedge-CH11

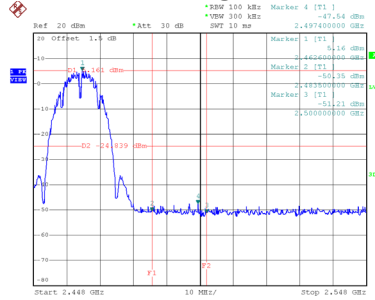

Date: 7.MAY.2019 11:19:56

### CH01 – 10th Harmonic of the fundamental frequency

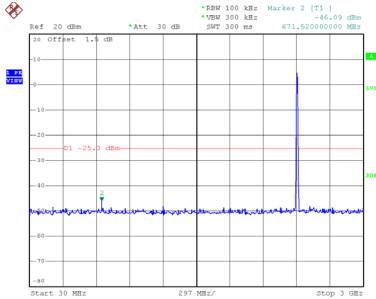

Date: 7.MAY.2019 11:17:00

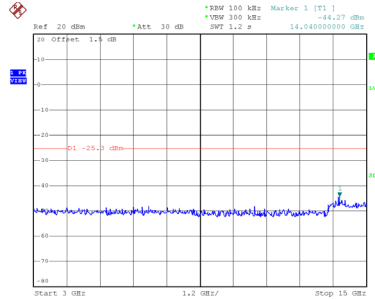

Date: 7.MAY.2019 11:17:08

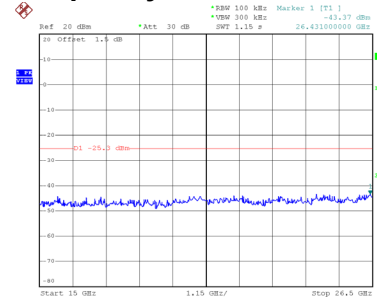

Date: 7.MAY.2019 11:17:16

### CH06 – 10th Harmonic of the fundamental frequency

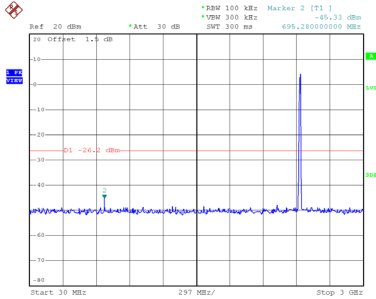

Date: 7.MAY.2019 11:18:42

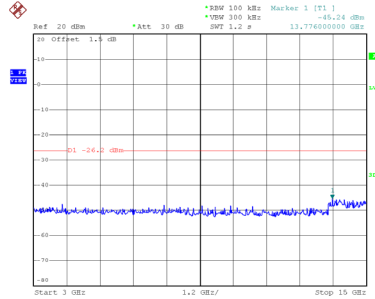

Date: 7.MAY.2019 11:18:50

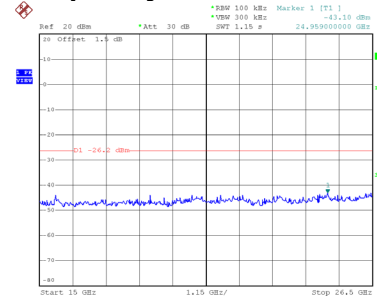

Date: 7.MAY.2019 11:18:59

### CH11 – 10th Harmonic of the fundamental frequency

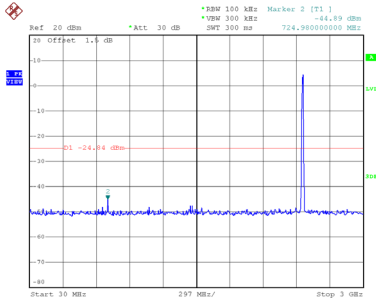

Date: 7.MAY.2019 11:20:37

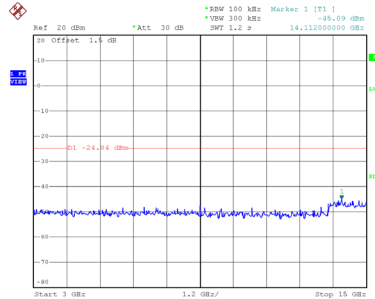

Date: 7.MAY.2019 11:20:45

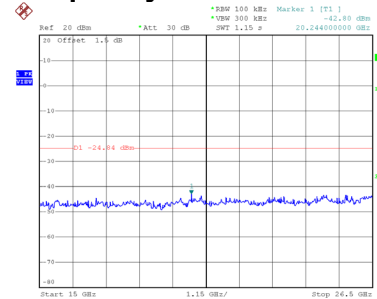

Date: 7.MAY.2019 11:20:54

Test Mode TX G Mode

### Bandedge-CH01

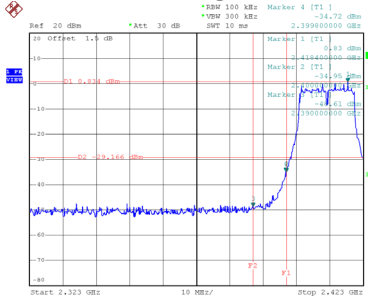

Date: 7.MAY.2019 11:22:54

### Bandedge-CH11

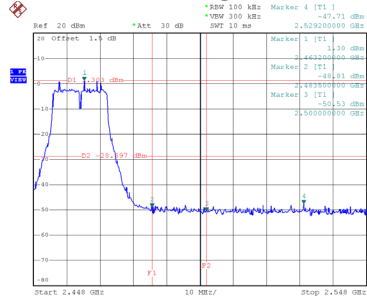

Date: 7.MAY.2019 11:27:28

### CH01 – 10th Harmonic of the fundamental frequency

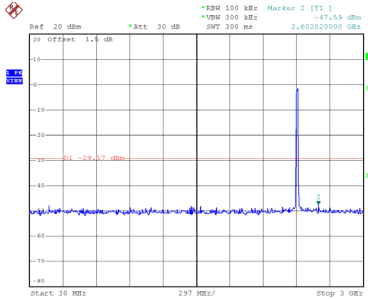

Date: 7.MAY.2019 11:23:22

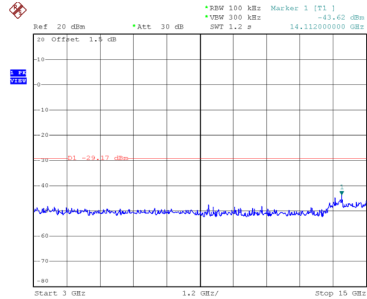

Date: 7.MAY.2019 11:23:31

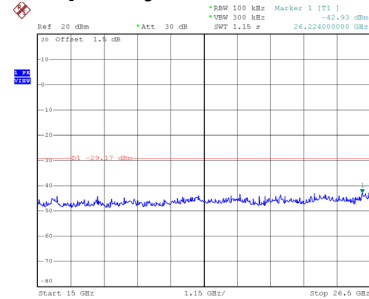

Date: 7.MAY.2019 11:23:39

### CH06 – 10th Harmonic of the fundamental frequency

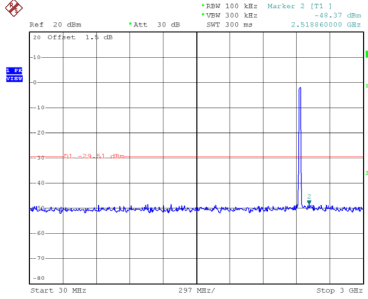

Date: 7.MAY.2019 11:25:18

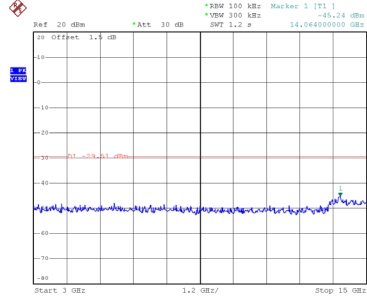

Date: 7.MAY.2019 11:25:26

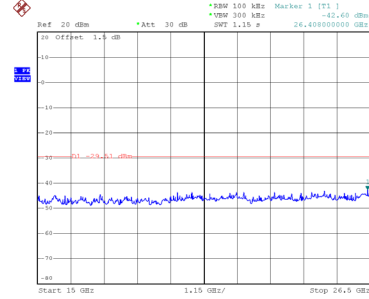

Date: 7.MAY.2019 11:25:34

### CH11 – 10th Harmonic of the fundamental frequency

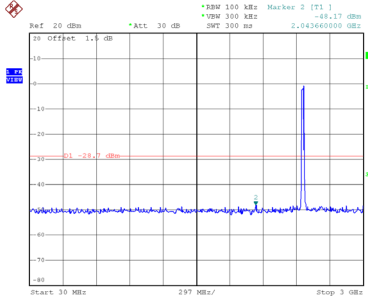

Date: 7.MAY.2019 11:27:57

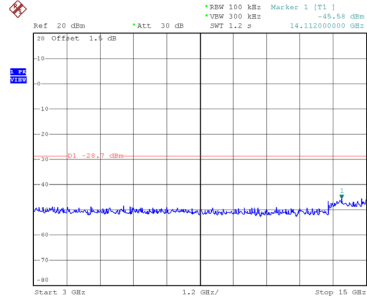

Date: 7.MAY.2019 11:28:05

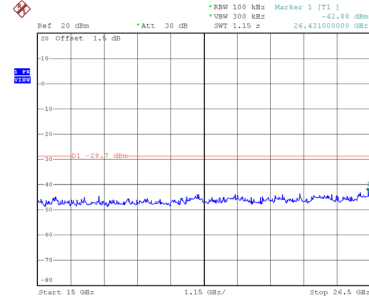

Date: 7.MAY.2019 11:28:13

Test Mode TX N-20M Mode

### Bandedge-CH01

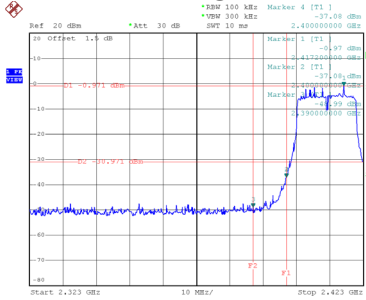

Date: 7.MAY.2019 11:31:44

### Bandedge-CH11

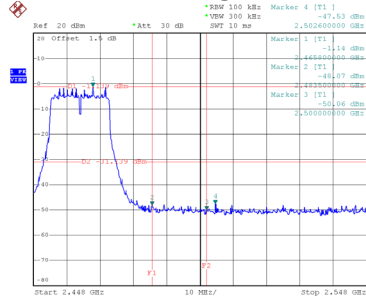

Date: 7.MAY.2019 11:43:30

### CH01 – 10th Harmonic of the fundamental frequency

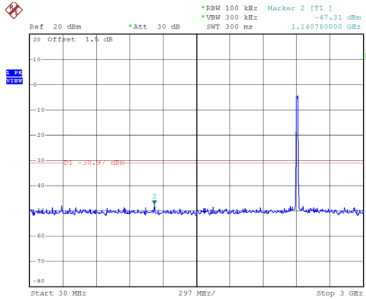

Date: 7.MAY.2019 11:32:11

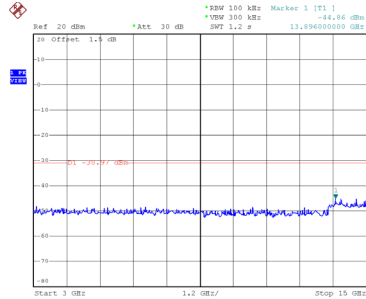

Date: 7.MAY.2019 11:32:19

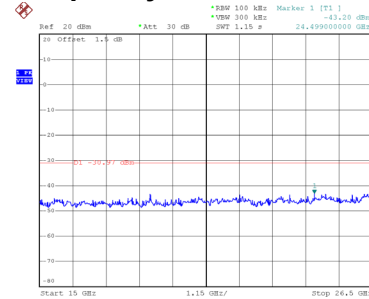

Date: 7.MAY.2019 11:32:27

### CH06 – 10th Harmonic of the fundamental frequency

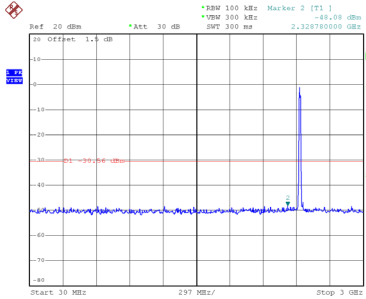

Date: 7.MAY.2019 11:36:14

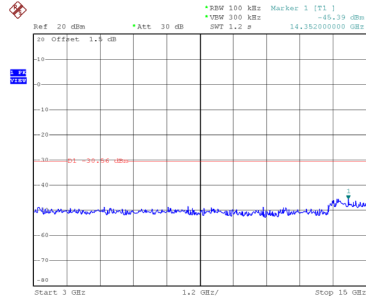

Date: 7.MAY.2019 11:36:22

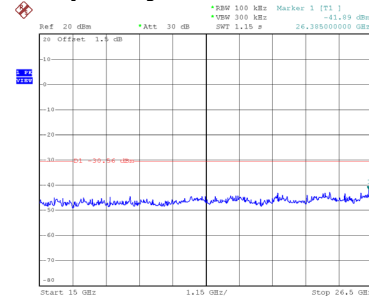

Date: 7.MAY.2019 11:36:30

### CH11 – 10th Harmonic of the fundamental frequency

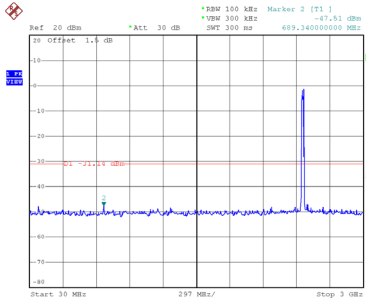

Date: 7.MAY.2019 11:43:57

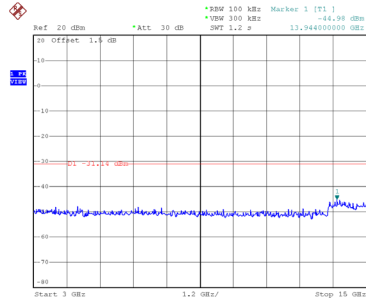

Date: 7.MAY.2019 11:44:05

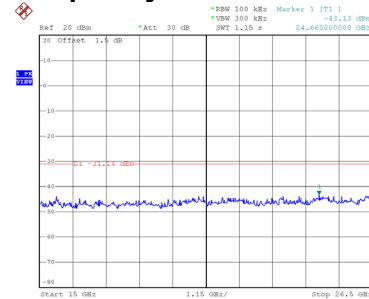

Date: 7.MAY.2019 11:44:13

Test Mode TX N-40M Mode

### Bandedge-CH03

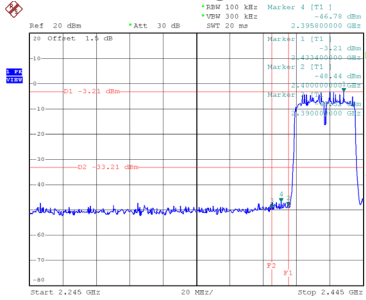

Date: 7.MAY.2019 11:46:20

### Bandedge-CH09

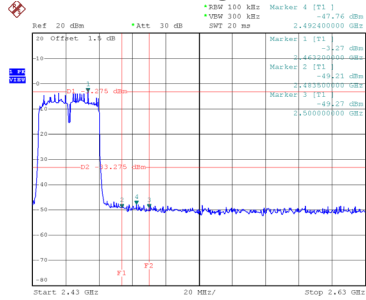

Date: 7.MAY.2019 11:51:21

### CH03 – 10th Harmonic of the fundamental frequency

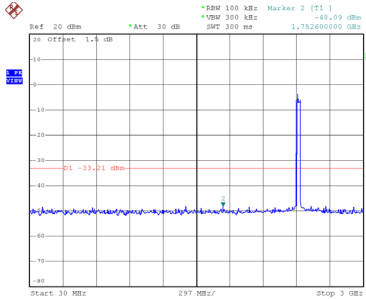

Date: 7.MAY.2019 11:46:48

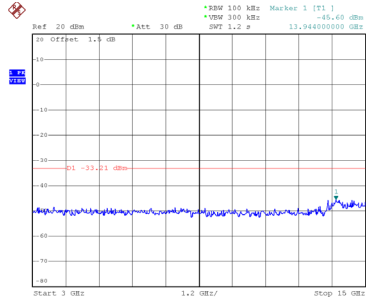

Date: 7.MAY.2019 11:46:56

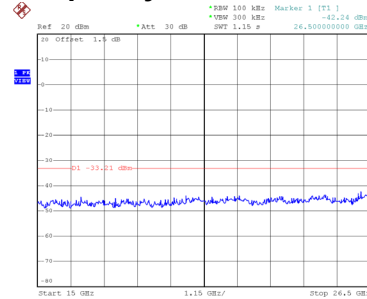

Date: 7.MAY.2019 11:47:04

### CH06 – 10th Harmonic of the fundamental frequency

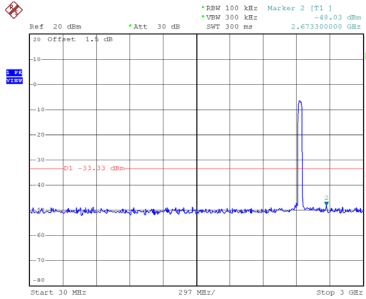

Date: 7.MAY.2019 11:49:27

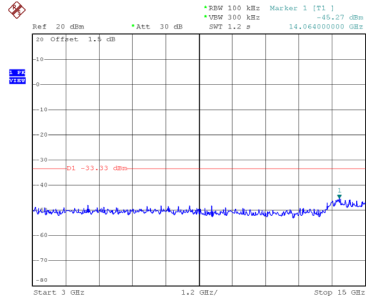

Date: 7.MAY.2019 11:49:35

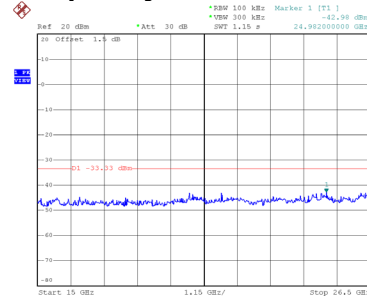

Date: 7.MAY.2019 11:49:43

### CH09 – 10th Harmonic of the fundamental frequency

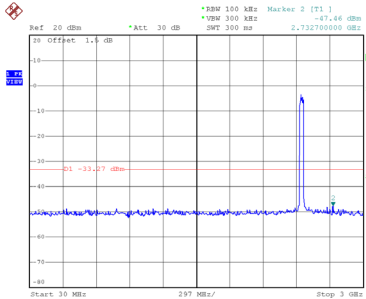

Date: 7.MAY.2019 11:51:47

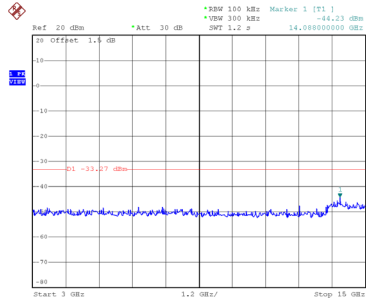

Date: 7.MAY.2019 11:51:56

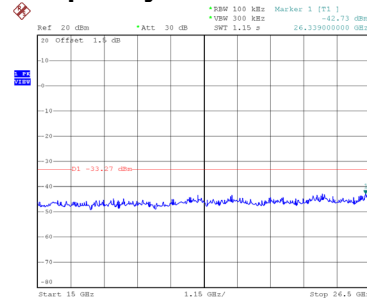

Date: 7.MAY.2019 11:52:04

## APPENDIX H - POWER SPECTRAL DENSITY

Test Mode	TX B Mode
-----------	-----------

Channel	Frequency (MHz)	Power Spectral Density (dBm/3kHz)	Max. Limit (dBm/3kHz)	Result
01	2412	-11.32	8	Complies
06	2437	-11.11	8	Complies
11	2462	-10.75	8	Complies

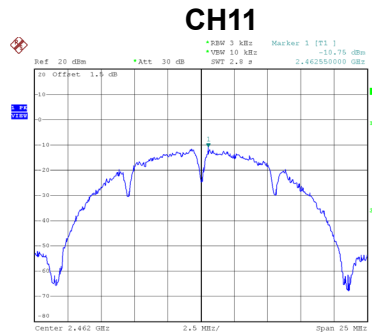
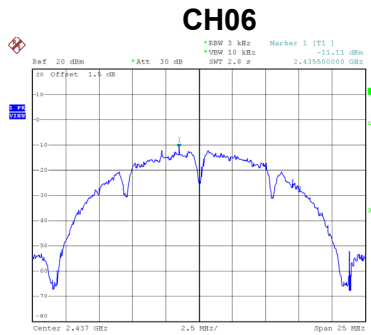
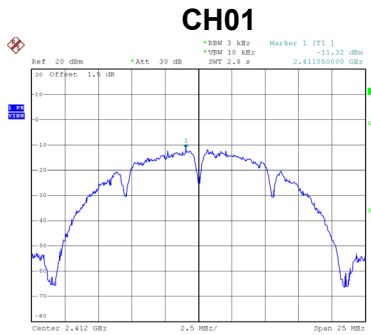

Test Mode	TX G Mode
-----------	-----------

Channel	Frequency (MHz)	Power Spectral Density (dBm/3kHz)	Max. Limit (dBm/3kHz)	Result
01	2412	-16.06	8	Complies
06	2437	-16.02	8	Complies
11	2462	-16.12	8	Complies

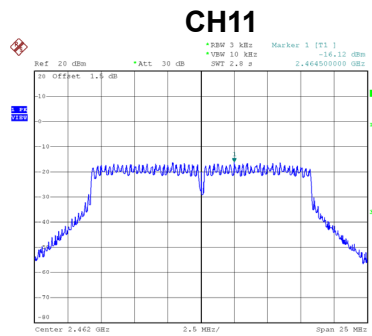
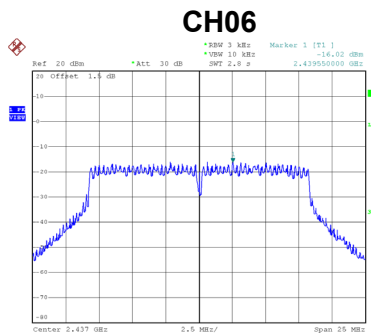
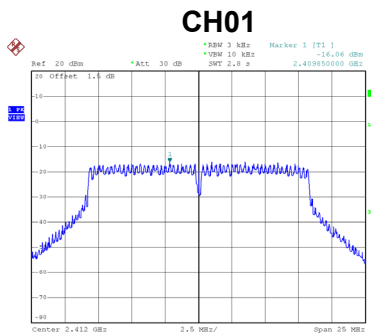



Test Mode	TX N-20M Mode
-----------	---------------

Channel	Frequency (MHz)	Power Spectral Density (dBm/3kHz)	Max. Limit (dBm/3kHz)	Result
01	2412	-16.65	8	Complies
06	2437	-17.56	8	Complies
11	2462	-16.44	8	Complies

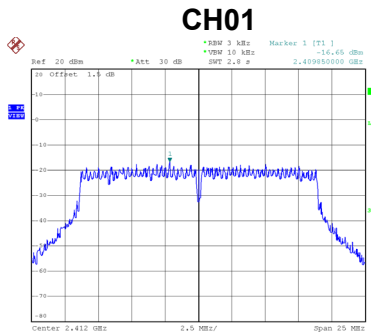

Date: 7.MAY.2019 11:35:20

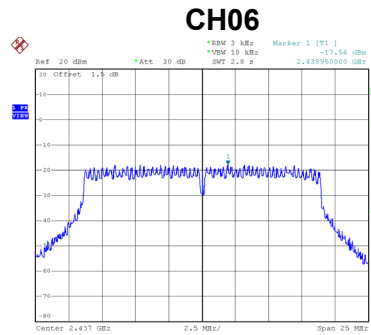

Date: 7.MAY.2019 11:42:55

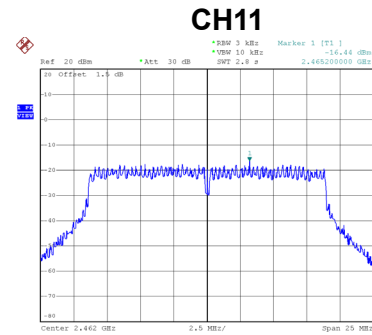

Date: 7.MAY.2019 11:45:14

Test Mode	TX N-40M Mode
-----------	---------------

Channel	Frequency (MHz)	Power Spectral Density (dBm/3kHz)	Max. Limit (dBm/3kHz)	Result
03	2422	-19.94	8	Complies
06	2437	-20.10	8	Complies
09	2452	-19.06	8	Complies

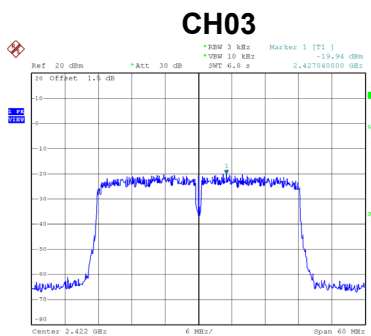

Date: 7.MAY.2019 11:48:27

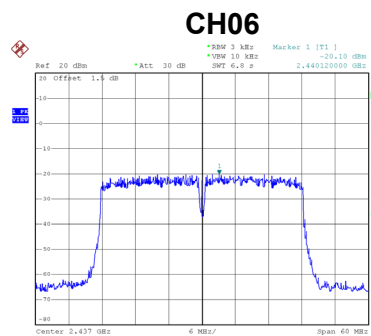

Date: 7.MAY.2019 11:50:45

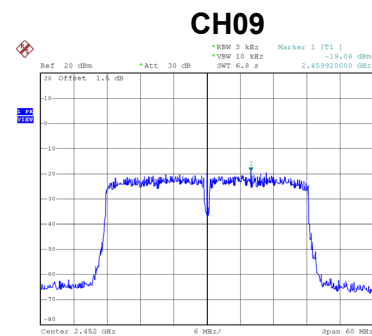

Date: 7.MAY.2019 11:53:13

End of Test Report