

FCC Radio Test Report

FCC ID: 2AC23-WCT3EM2611
FCC 47 CFR Part 15 Subpart E

Product : WIFI Module

Trade Name : GSD

Model Number : WCT3EM2611

Firmware Version Identification Number (FVIN): 1.0

Issued for

Hui Zhou Gaoshengda Technology Co.,LTD

NO.75 Zhongkai Development Area, Huizhou, Guangdong, China

Issued by

Shenzhen ATL Testing Technology Co., Ltd.

F/4, Building 10, Dayuan Industrial Zone, Xili Town, Nanshan District, Shenzhen,
China

Tel.: +86-0755-26909822 Fax.: +86-0755-61605504

Website: www.atllab.org

Note: This report shall not be reproduced except in full, without the written approval of Shenzhen ATL Testing Technology Co., Ltd.. This document may be altered or revised by Shenzhen ATL Testing Technology Co., Ltd. personnel only, and shall be noted in the revision section of the document. The test results in the report only apply to the tested sample

TEST RESULT CERTIFICATION

Product : WIFI Module
Applicant..... : Hui Zhou Gaoshengda Technology Co.,LTD
Address : NO.75 Zhongkai Development Area, Huizhou, Guangdong, China
Manufacturer..... : Hui Zhou Gaoshengda Technology Co.,LTD
Address : NO.75 Zhongkai Development Area, Huizhou, Guangdong, China
Model No. : WCT3EM2611
Standards : FCC Part 15 Subpart C (15.407)
Test Method..... : ANSI C63.10: 2013
KDB 789033 D02 General UNII Test Procedures New Rules v01

The above equipment has been tested by Shenzhen ATL Testing Technology Co., Ltd. and found compliance with the requirements set forth in the technical standards mentioned above. The results of testing in this report apply only to the product/system, which was tested. Other similar equipment will not necessarily produce the same results due to production tolerance and measurement uncertainties.

Test.....:

Date of receipt of test item 2016-09-20
Date(s) of performance of test 2016-09-21 to 2016-10-31
Test Result.....: Pass

Testing by	:	<u>Si feifei</u>	Date	:	<u>2016-10-31</u>
		(Si feifei)			
Check by	:	<u>Xie Lingling</u>	Date	:	<u>2016-11-04</u>
		(Xie Lingling)			
Approved by	:	<u>Xu Peng</u>	Date	:	<u>2016-11-04</u>
		(Xu Peng)			

Table of Contents	Page
1 . TEST SUMMARY	5
1.1 TEST FACILITY	6
1.2 MEASUREMENT UNCERTAINTY	6
2 . GENERAL INFORMATION	7
2.1 GENERAL DESCRIPTION OF EUT	7
2.2 DESCRIPTION OF TEST MODES	9
2.3 DESCRIPTION OF TEST SETUP	11
2.4 DESCRIPTION TEST PERIPHERAL AND EUT PERIPHERAL	12
2.5 EUT Exercise Software	13
3 . CONDUCTED EMISSION TEST	14
3.1 CONDUCTED EMISSION MEASUREMENT (Frequency Range 150KHz-30MHz)	14
3.2 TEST PROCEDURE	14
3.3 TEST SETUP	15
3.4 TEST INSTRUMENTS	15
3.5 EUT OPERATING CONDITIONS	15
3.6 TEST RESULTS	16
4 . RADIATED EMISSION MEASUREMENT	18
4.1 RADIATED EMISSION LIMIT (Frequency Range 9KHz-1000MHz)	18
4.2 TEST PROCEDURE	19
4.3 TEST SETUP	19
4.4 TEST INSTRUMENTS	20
4.5 EUT OPERATING CONDITIONS	21
4.6 TEST RESULTS	22
5 . MAXIMUM CONDUCTED OUTPUT POWER MEASUREMENT	54
5.1 LIMITS	54
5.2 TEST PROCEDURE	54
5.3 TEST SETUP	54
5.4 TEST INSTRUMENTS	54
5.5 EUT OPERATING CONDITIONS	54
5.6 TEST RESULTS	54
6 . OCCUPIED BANDWIDTH MEASUREMENT	57
6.1 LIMITS	57
6.2 TEST PROCEDURE	57

Table of Contents	Page
6.3 TEST SETUP	57
6.4 TEST INSTRUMENTS	57
6.5 EUT OPERATING CONDITIONS	58
6.6 TEST RESULTS	58
7 . POWER SPECTRAL DENSITY	81
7.1 LIMITS	81
7.2 TEST PROCEDURE	81
7.3 TEST SETUP	81
7.4 TEST INSTRUMENTS	81
7.5 EUT OPERATING CONDITIONS	81
7.6 TEST RESULTS	81
8 . BAND EDGE EMISSION	118
8.1 LIMITS	118
8.2 TEST PROCEDURE	118
8.3 TEST SETUP	118
8.4 TEST INSTRUMENTS	118
8.5 EUT OPERATING CONDITIONS	118
8.6 TEST RESULTS	118
9 . ANTENNA REQUIREMENT	131
9.1 LIMITS	131
9.2 TEST PROCEDURE	131
9.3 TEST SETUP	131
9.4 TEST INSTRUMENTS	131
9.5 EUT OPERATING CONDITIONS	131
9.6 TEST RESULTS	132
10 . ANTENNA REQUIREMENT	134
10.1 REQUIREMENT	134
10.2 ANTENNA CONNECTOR CONSTRUCTION	134

1. TEST SUMMARY

Test procedures according to the technical standards:

FCC Part 15 Subpart E (15.407)/RSS 247				
Standard Section		Test Item	Judgment	Remark
15.207	RSS Gen 7.2.4	AC Power Conducted Emission	PASS	
15.407(b)	RSS 247 6.2.1&6.2.4	Band Edge Emission	PASS	
15.407(a)	RSS 247 6.2	Peak Output Power	PASS	
15.407(a)	RSS 247 6.2.1&6.2.4	6dB/26dB RF Bandwidth	PASS	
15.407(a)	RSS 247 6.2.1&6.2.4	Power Spectral Density	PASS	
15.407(b)/ 15.205	RSS 247 6.2.1&6.2.4	Transmitter Radiated Emissions	PASS	
15.407(g)	RSS 247 6.2.4	Frequency Stability	PASS	
15.203		Antenna Requirement	PASS	

NOTE:

(1) "N/A" denotes test is not applicable in this Test Report

(2) The test results of this report relate only to the tested sample(s) identified in this report.

1.1 TEST FACILITY

Shenzhen ATL Testing Technology Co., Ltd.

Add. : F/4, Building 10, Dayuan Industrial Zone, Xili Town, Nanshan District, Shenzhen, China

1.2 MEASUREMENT UNCERTAINTY

The reported uncertainty of measurement $y \pm U$, where expanded uncertainty U is based on a standard uncertainty multiplied by a coverage factor of $k=2$, providing a level of confidence of approximately **95** %.

A. Conducted Emission :

The measurement uncertainty is evaluated as ± 3.2 dB.

B. Radiated Measurement :

The measurement uncertainty is evaluated as ± 3.7 dB.

2. GENERAL INFORMATION

2.1 GENERAL DESCRIPTION OF EUT

Equipment	WIFI Module
Model Name	WCT3EM2611
Additional Model Number(s)	N/A
Model Difference	N/A
Frequency Range	U-NII-1: 5150~5250MHz U-NII-3: 5725~5850MHz
Modulation Type	802.11a: OFDM(QPSK, BPSK, 16QAM) 802.11n: OFDM(QPSK, BPSK, 16QAM, 64QAM) 802.11ac: OFDM(QPSK, BPSK, 16QAM, 64QAM, 256QAM)
Data Rate	802.11a: 6/9/12/18/24/36/48/54 Mbps 802.11n: up to 300 Mbps 802.11ac: up to 866.7 Mbps
RF Output Power	U-NII-1: 802.11a: 15.92 dBm 802.11n(HT20): 14.98 dBm 802.11n(HT40): 13.31 dBm 802.11ac(20): 13.38 dBm 802.11ac(40): 13.12 dBm 802.11ac(80): 13.29 dBm U-NII-3: 802.11a: 15.14 dBm 802.11n(HT20): 15.11 dBm 802.11n(HT40): 13.58 dBm 802.11ac(20): 15.35 dBm 802.11ac(40): 13.15 dBm 802.11ac(80): 12.87 dBm
Antenna Type	PIFA Antenna Max. Gain: 5150~5250: 3.0 dBi Max. Gain: 5725~5850: 3.0 dBi
Power Source	DC Powered by host system.
Power Rating	DC 5V from USB interference.
Remark	More details EUT technical specifications, please refer to the User's Manual.

Note:

- (1) This Test Report is FCC Part 15 Subpart C, 15.407 for IEEE 802.11a/n/ac. And the Test procedure follows the FCC KDB 789033 D02 General UNII Test Procedures New Rules v01.

(2) Transmitting mode with antennas

Mode	TX Antenna (s)
802.11a	1
802.11n(HT20)	2
802.11n(HT40)	2
802.11ac(20)	2
802.11ac(40)	2
802.11ac(80)	2

(3) Channel List.

5 GHz U-NII-1 Band				
Frequency Band	Channel No.	Frequency	Channel No.	Frequency
5150~5250 MHz	36	5180 MHz	44	5220 MHz
	38	5190 MHz	46	5230 MHz
	40	5200 MHz	48	5240 MHz
	42	5210 MHz		

For 802.11a, 802.11n(HT20) and 802.11ac(20), use channel 36, 40, 44, 48
 For 802.11n(HT40) and 802.11ac(40), use channel 38, 46
 For 802.11ac(80), use channel 42

5 GHz U-NII-3 Band				
Frequency Band	Channel No.	Frequency	Channel No.	Frequency
5725~5850 MHz	149	5745 MHz	157	5785 MHz
	151	5755 MHz	159	5795 MHz
	153	5765 MHz	161	5805 MHz
	155	5775 MHz	165	5825 MHz

For 802.11a, 802.11n(HT20) and 802.11ac(20), use channel 149, 153, 157, 161, 165
 For 802.11n(HT40) and 802.11ac(40), use channel 151, 159
 For 802.11ac(80), use channel 155

2.2 DESCRIPTION OF TEST MODES

To investigate the maximum EMI emission characteristics generates from EUT, the test system was pre-scanning tested base on the consideration of following EUT operation mode or test configuration mode which possible have effect on EMI emission level. Each of these EUT operation mode(s) or test configuration mode(s) mentioned above was evaluated respectively.

Pretest Mode	Description
Mode 1	WiFi TX Mode
Mode 2	WiFi TX 802.11a Mode
Mode 3	WiFi TX 802.11n(HT20)Mode
Mode 4	WiFi TX 802.11n(HT40) Mode
Mode 5	WiFi TX 802.11ac(20)Mode
Mode 6	WiFi TX 802.11ac(40) Mode
Mode 7	WiFi TX 802.11ac(80) Mode

For Conducted Test	
Final Test Mode	Description
Mode 2	WiFi TX Mode

For Radiated Test	
Final Test Mode	Description
Mode 1	WiFi TX Mode
Mode 2	WiFi TX 802.11a Mode
Mode 3	WiFi TX 802.11n(HT20)Mode
Mode 4	WiFi TX 802.11n(HT40) Mode
Mode 5	WiFi TX 802.11ac(20)Mode
Mode 6	WiFi TX 802.11ac(40) Mode
Mode 7	WiFi TX 802.11ac(80) Mode

Note:

- (1) Software used to control the EUT for staying in continuous transmitting mode was programmed. After verification, all tests were carried out with the worst case test modes as shown below.
- (2) IEEE 802.11a Mode with OFDM:
U-NII-1: Channel (36/40/48) with 6Mbps data rate were chosen for full testing.
U-NII-3: Channel (149/157/165) with 6Mbps data rate were chosen for full testing.
- (3) IEEE 802.11n(HT20) Mode:
U-NII-1:Channel (36/40/48) with MCS 0 data rate were chosen for full testing.
U-NII-3:Channel (149/157/165) with MCS 0 data rate were chosen for full testing.
- (4) IEEE 802.11n(HT40) Mode:
U-NII-1: Channel (38/46) with MCS 0 data rate were chosen for full testing.
U-NII-3: Channel (151/159) with MCS 0 data rate were chosen for full testing.
- (5) IEEE 802.11ac(20) Mode:
U-NII-1:Channel (36/40/48) with MCS 1/Nss2 data rate were chosen for full testing.
U-NII-3:Channel (149/157/165) with MCS 1/Nss2 data rate were chosen for full testing.
- (6) IEEE 802.11ac(40) Mode:
U-NII-1: Channel (38/46) with MCS 1/Nss2 data rate were chosen for full testing.
U-NII-3: Channel (151/159) with MCS 1/Nss2 data rate were chosen for full testing.
- (7) IEEE 802.11ac(80) Mode:
U-NII-1: Channel (42) with MCS 1/Nss2 data rate were chosen for full testing.
U-NII-3: Channel (155) with MCS 1/Nss2 data rate were chosen for full testing.
- (8) By preliminary testing and verifying three axis (X, Y and Z) position of EUT transmitted status, it was found that "X axis" position was the worst, then the final test was executed the worst condition and test data were recorded in this report.

2.3 DESCRIPTION OF TEST SETUP

Radiated Emission

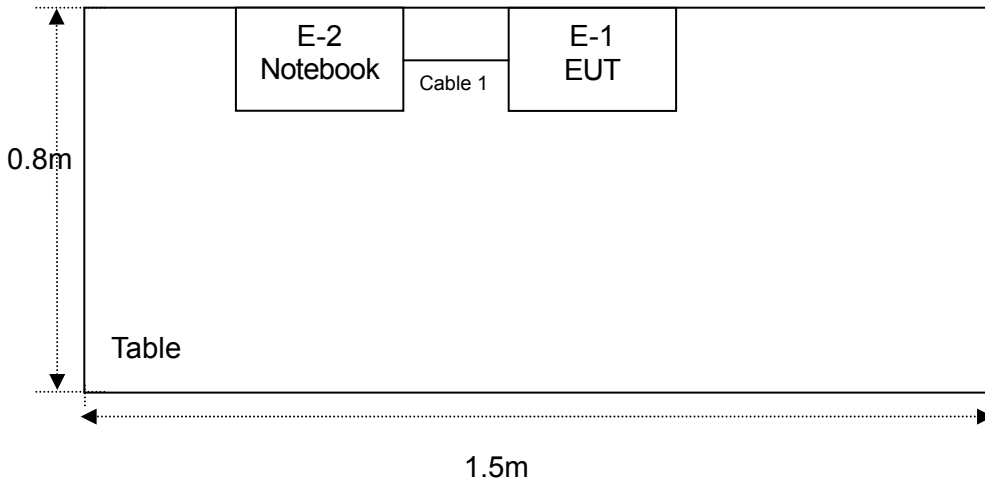

2.4 DESCRIPTION TEST PERIPHERAL AND EUT PERIPHERAL

The EUT has been tested as an independent unit together with other necessary accessories or support units. The following support units or accessories were used to form a representative test configuration during the tests.

Item	Equipment	Mfr/Brand	Model/Type No.	Series No.	Note
E-1	WIFI Module	GSD	WCT3EM2611	N/A	EUT
E-2	Notebook	LENOVO	P405	DOC	

Item	Shielded Type	Ferrite Core	Length	Note
1	NO	NO	15cm	

Note:

- (1) The support equipment was authorized by Declaration of Confirmation.
- (2) For detachable type I/O cable should be specified the length in cm in 『Length』 column.
- (3) “YES” means “shielded” “with core”; “NO” means “unshielded” “without core”.

2.5 EUT Exercise Software

Power Parameters for Testing			
Test Software Version	MT7662UQA.exe		
Mode	Channel/ Parameters U-NII-1		
802.11a	CH 36	CH 40	CH 48
	DEF	DEF	DEF
802.11n(HT20)	CH 36	CH 40	CH 48
	DEF	DEF	DEF
802.11ac(20)	CH 36	CH 40	CH 48
	DEF	DEF	DEF
802.11n(HT40)	CH 38	CH 46	
	DEF	DEF	
802.11ac(40)	CH 38	CH 46	
	DEF	DEF	
802.11ac(80)	CH 42		
	DEF		

Power Parameters for Testing			
Test Software Version	MT7662UQA.exe		
Mode	Channel/ Parameters U-NII-3		
802.11a	CH 149	CH 157	CH 165
	DEF	DEF	DEF
802.11n(HT20)	CH 149	CH 157	CH 165
	DEF	DEF	DEF
802.11ac(20)	CH 149	CH 157	CH 165
	DEF	DEF	DEF
802.11n(HT40)	CH 151	CH 159	
	DEF	DEF	
802.11ac(40)	CH 151	CH 159	
	DEF	DEF	
802.11ac(80)	CH 155		
	DEF		

3. CONDUCTED EMISSION TEST

3.1 CONDUCTED EMISSION MEASUREMENT (Frequency Range 150KHz-30MHz)

FREQUENCY (MHz)	Quasi-peak	Average
	dBuV	dBuV
0.15 -0.5	66 - 56 *	56 - 46 *
0.50 -5.0	56.00	46.00
5.0 -30.0	60.00	50.00

Note:

- (1) The tighter limit applies at the band edges.
- (2) The limit of " * " marked band means the limitation decreases linearly with the logarithm of the frequency in the range.

The following table is the setting of the receiver

Receiver Parameters	Setting
Attenuation	10 dB
Start Frequency	0.15 MHz
Stop Frequency	30 MHz
IF Bandwidth	9 kHz

3.2 TEST PROCEDURE

- a. The EUT was placed 0.8 meters from the horizontal ground plane with EUT being connected to the power mains through a line impedance stabilization network (LISN). All other support equipments powered from additional LISN(s). The LISN provide 50 Ohm/ 50uH of coupling impedance for the measuring instrument.
- b. Interconnecting cables that hang closer than 40 cm to the ground plane shall be folded back and forth in the center forming a bundle 30 to 40 cm long.
- c. I/O cables that are not connected to a peripheral shall be bundled in the center. The end of the cable may be terminated, if required, using the correct terminating impedance. The overall length shall not exceed 1 m.
- d. LISN at least 80 cm from nearest part of EUT chassis.
- e. For the actual test configuration, please refer to the related Item –EUT Test Photos.

3.3 TEST SETUP

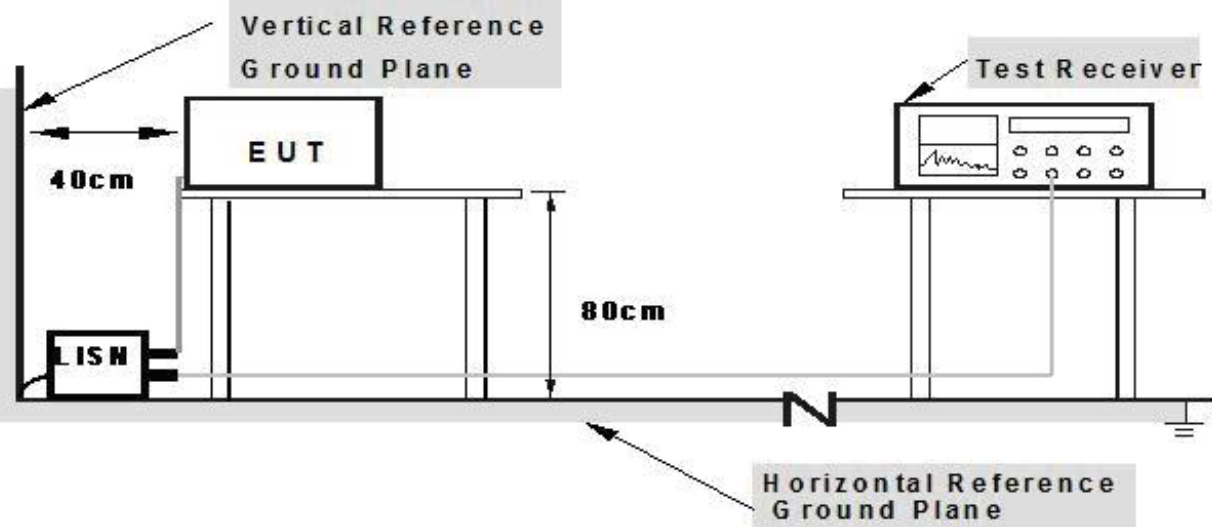

- Note: 1. Support units were connected to second LISN.**
2. Both of LISNs (AMN) are 80 cm from EUT and at least 80 from other units and other metal planes

3.4 TEST INSTRUMENTS

Equipment	Manufacturer	Type No.	Serial No.	Last calibration	Calibrated until	Calibration period
LISN	R&S	NSLK81	8126466	Jul. 04. 2016	Jul. 03. 2017	1 year
LISN	R&S	NSLK81	8126487	Dec. 23, 2015	Dec. 22, 2016	1 year
50Ω Switch	ANRITSU CORP	MP59B	6200983704	Jul. 04. 2016	Jul. 03. 2017	1 year
Test Cable	N/A	C01	N/A	Jul. 04. 2016	Jul. 03. 2017	1 year
Test Cable	N/A	C02	N/A	Jul. 04. 2016	Jul. 03. 2017	1 year
Test Cable	N/A	C03	N/A	Jul. 04. 2016	Jul. 03. 2017	1 year
EMI Test Receiver	R&S	ESCI	1166.595	Jul. 04. 2016	Jul. 03. 2017	1 year
Passive Voltage Probe	ESH2-Z3	R&S	100196	Jul. 04. 2016	Jul. 03. 2017	1 year

3.5 EUT OPERATING CONDITIONS

The EUT tested system was configured as the statements of 2.3 Unless otherwise a special operating condition is specified in the follows during the testing.

3.6 TEST RESULTS

EUT :	WIFI Module	Model Name. :	WCT3EM2611
Temperature :	26 °C	Relative Humidity :	56%
Pressure :	1010hPa	Terminal:	Line
Test Mode :	WIFI TX Mode (802.11a CH36)		
Test Voltage :	120V/ 60Hz		

No.	Mk.	Freq. MHz	Reading Level dBuV	Correct Factor dB	Measure- ment dBuV	Limit dBuV	Over dB	Detector
1		0.1500	32.91	9.92	42.83	66.00	-23.17	peak
2	*	0.4020	28.81	10.02	38.83	57.81	-18.98	peak
3		0.6660	21.88	10.10	31.98	56.00	-24.02	peak
4		1.2660	22.08	10.06	32.14	56.00	-23.86	peak
5		1.6580	22.01	10.06	32.07	56.00	-23.93	peak
6		2.6860	20.62	10.04	30.66	56.00	-25.34	peak

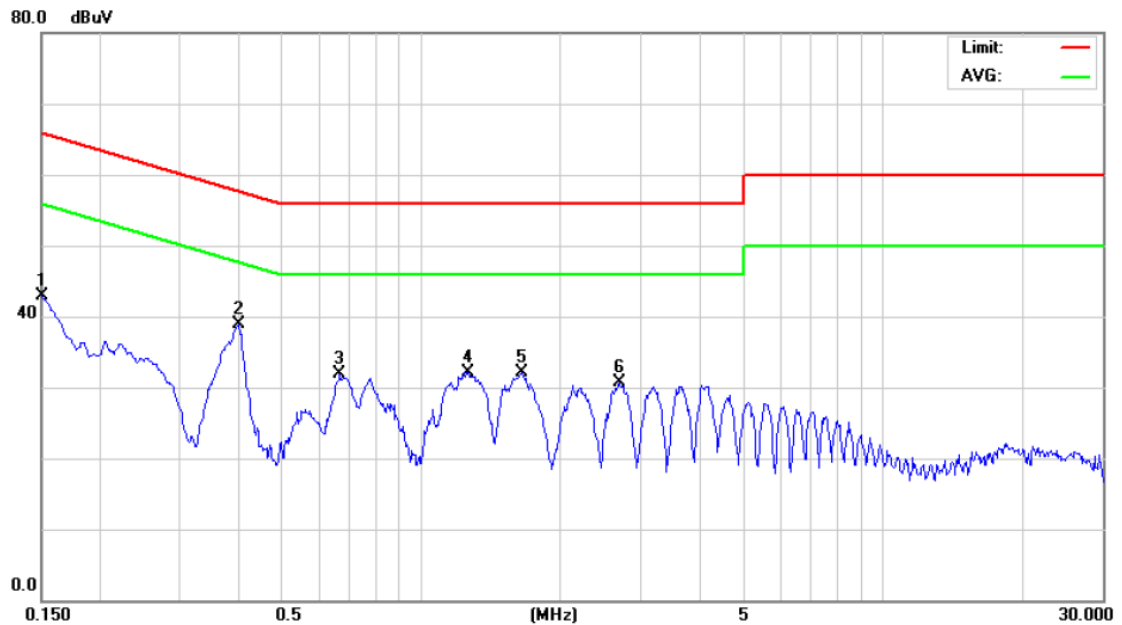

EUT :	WIFI Module	Model Name. :	WCT3EM2611
Temperature :	26 °C	Relative Humidity :	56%
Pressure :	1010hPa	Terminal:	Neutral
Test Mode :	WIFI TX Mode (802.11a CH36)		
Test Voltage :	120V/ 60Hz		

No.	Mk.	Freq. MHz	Reading Level dBuV	Correct Factor dB	Measure- ment dBuV	Limit dBuV	Over dB	Detector
1		0.1500	32.19	10.12	42.31	66.00	-23.69	peak
2	*	0.3980	29.29	10.05	39.34	57.90	-18.56	peak
3		0.6700	22.02	10.02	32.04	56.00	-23.96	peak
4		1.6060	22.65	10.10	32.75	56.00	-23.25	peak
5		3.2060	21.62	10.06	31.68	56.00	-24.32	peak
6		4.0940	21.84	10.06	31.90	56.00	-24.10	peak

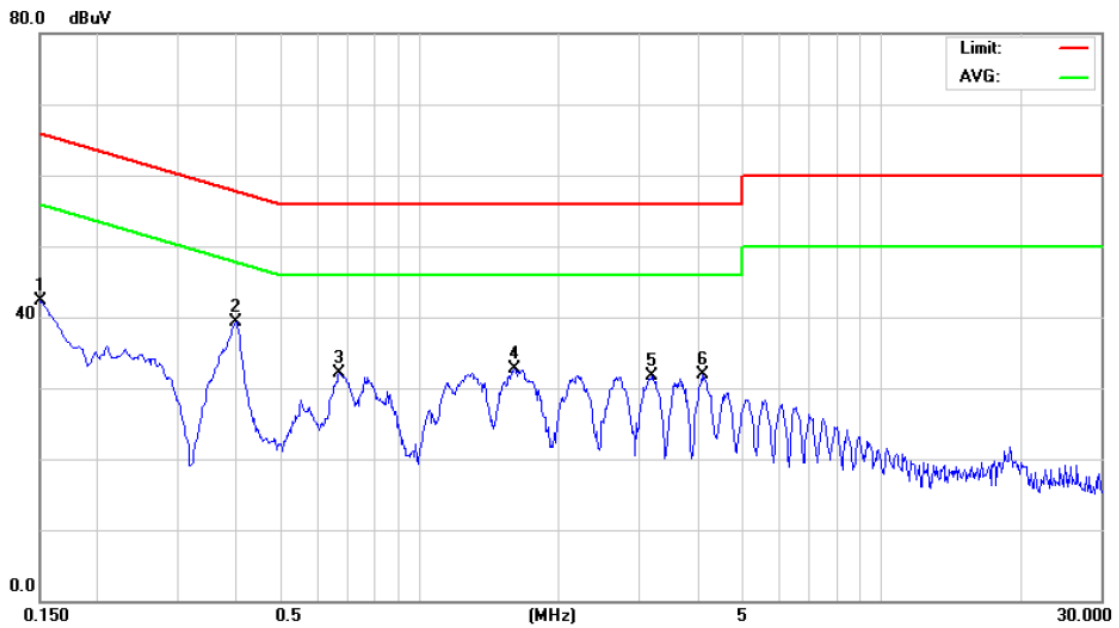

4. RADIATED EMISSION MEASUREMENT

4.1 RADIATED EMISSION LIMIT (Frequency Range 9KHz-1000MHz)

20 dBc in any 100 kHz bandwidth outside the operating frequency band. In case the emission fall within the restricted band specified on 15.205(a) and RSS-247 Section 3, then the 15.209(a) and RSS-General limit in the table below has to be followed.

FREQUENCY (MHz)	Field Strength (uV/m at meter)	Measurement Distance (meters)
0.009 -0.490	2400/F(KHz)	300
0.490 -1.705	24000/F(KHz)	30
1.705 -30.0	30	30
30 -88	100	3
88 -216	150	3
216~960	200	3
Above 960	500	3

RADIATED EMISSION LIMITS (Above 1000MHz)

FREQUENCY (MHz)	Class A (dBuV/m)(at 3 M)		Class B (dBuV/m)(at 3 M)	
	Peak	Average		Peak
Above 1000	80	60	74	54

Limits of emission out of the restricted bands

FREQUENCY (MHz)	EIRP Limits (dBm)	Equivalent Field Strength (dBuV/m)(at 3 M)
5150~5250	-27	68.3
5725~5825	-27 (beyond 10 MHz of the band edge)	68.3
	-17 (within 10 MHz of the band edge)	78.3

Note:

- (1) The limit for radiated test was performed according to FCC PART 15C.
- (2) The tighter limit applies at the band edges.
- (2) Emission Level(dBuV/m)=20log Emission Level(uV/m)

The following table is the setting of the receiver

Receiver Parameter	Setting
Attenuation	Auto
Start Frequency~ Stop Frequency	9kHz~150kHz/ RB 200Hz for QP
Start Frequency~ Stop Frequency	150kHz~30MHz/ RB 9kHz for QP
Start Frequency~ Stop Frequency	30MHz~1000MHz/ RB120kHz for QP

The following table is the setting of the spectrum

Spectrum Parameter	Setting
Attenuation	Auto
Start Frequency	1000 MHz
Stop Frequency	10 th carrier harmonic
RB/ VB (emission in restricted band)	1MHz/ 3 MHz for Peak, 1MHz/ 10Hz for Average

4.2 TEST PROCEDURE

- a. The measuring distance of at 3 m shall be used for measurements at frequency up to 1GHz. For frequencies above 1GHz, any suitable measuring distance may be used.
- b. The EUT was placed on the top of a rotating table 0.8 meters above the ground at a 3 meter open area test site. The table was rotated 360 degrees to determine the position of the highest radiation.
- c. The height of the equipment or of the substitution antenna shall be 1.5 m; the height of the test antenna shall vary between 1 m to 4 m. Both horizontal and vertical polarizations of the antenna are set to make the measurement.
- d. The initial step in collecting conducted emission data is a spectrum analyzer peak detector mode pre-scanning the measurement frequency range. Significant peaks are then marked and then Quasi Peak detector mode re-measured, above 1G Average detector mode will be instead.
- e. If the Peak Mode measured value compliance with and lower than Quasi Peak Mode Limit, the EUT shall be deemed to meet QP Limits and then no additional QP Mode measurement performed.
- f. For the actual test configuration, please refer to the related Item –EUT Test Photos.

Note:

Both horizontal and vertical antenna polarities were tested.

And performed pretest to three orthogonal axis. The worst case emissions were reported.

4.3 TEST SETUP

(A) Radiated Emission Test Set-Up Frequency Below 30MHz

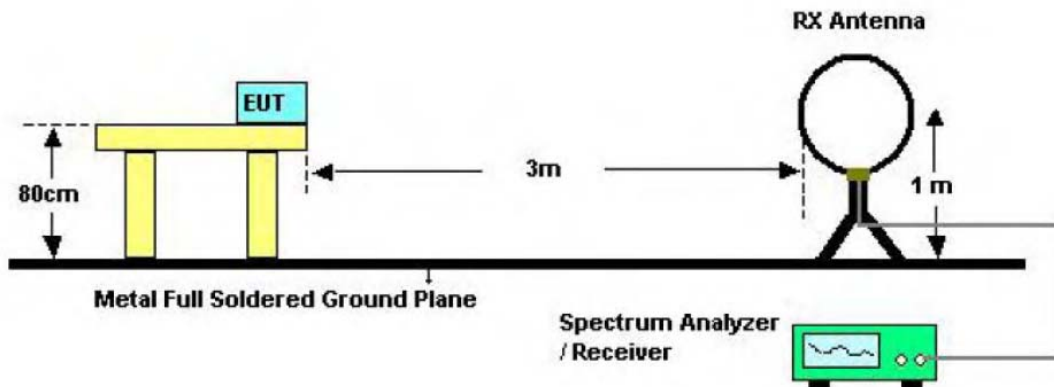

(B) Radiated Emission Test Set-Up Frequency Below 1 GHz

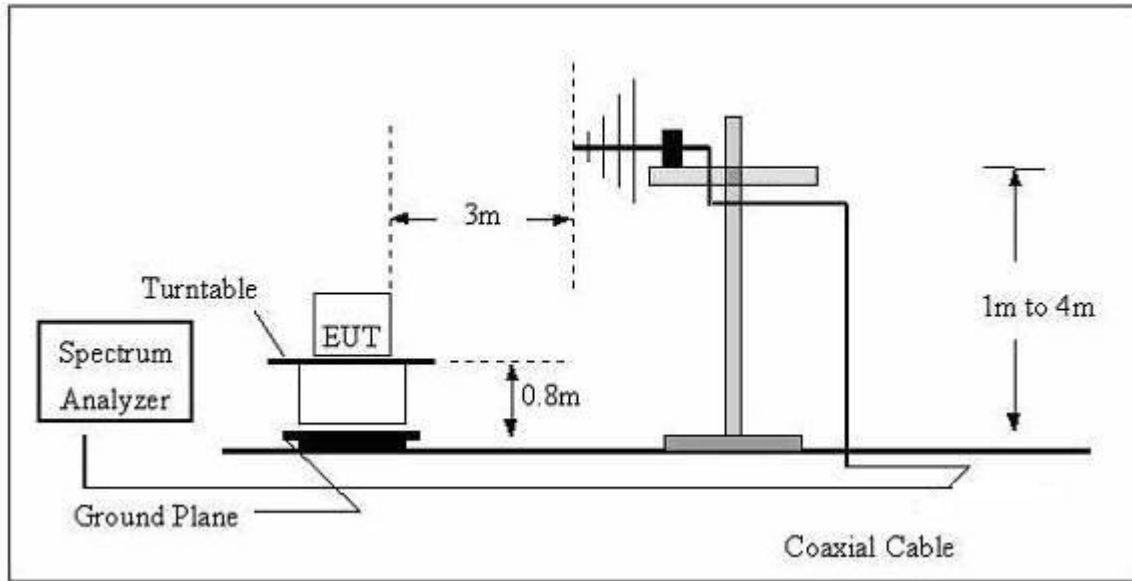

(C) Radiated Emission Test Set-Up Frequency Above 1GHz

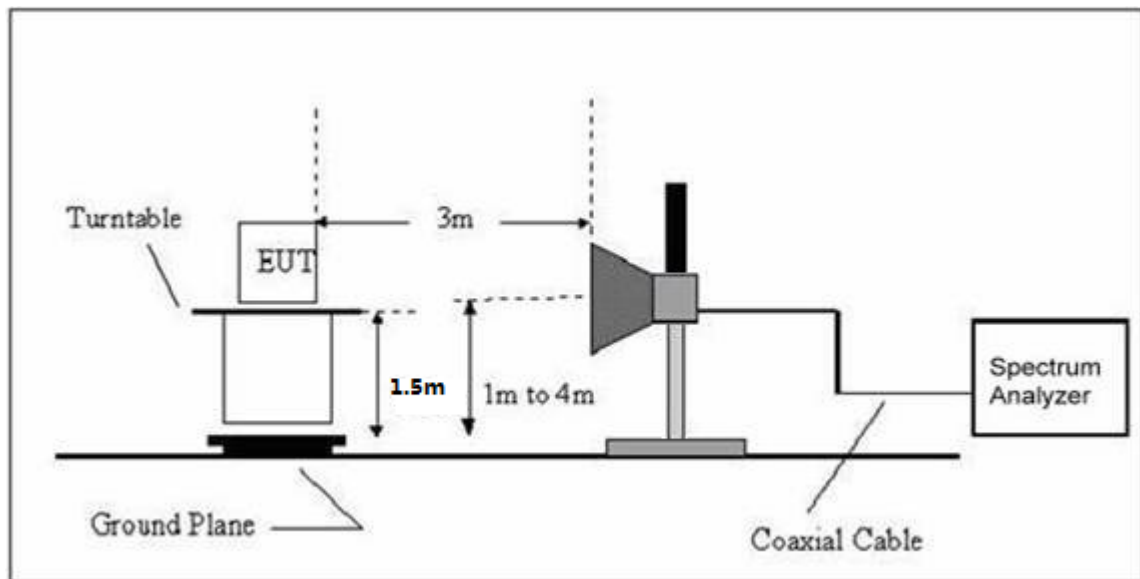

4.4 TEST INSTRUMENTS

Equipment	Manufacturer	Type No.	Serial No.	Last calibration	Calibrated until	Calibration period
Broadband Antenna	R&S	VULB 9168	VULB 9168-456	Jul. 04. 2016	Jul. 03. 2017	1 year
Test Cable	N/A	R-01	N/A	Dec. 23, 2015	Dec. 22, 2016	1 year
Test Cable	N/A	R-02	N/A	Dec. 23, 2015	Dec. 22, 2016	1 year
EMI Test Receiver	R&S	ESCI	101324	Jul. 04. 2016	Jul. 03. 2017	1 year
Antenna Mast	EM	SC100_1	N/A	N/A	N/A	N/A

Turn Table	EM	SC100	060531	N/A	N/A	N/A
50Ω Switch	Anritsu Corp	MP59B	6200983705	Jul. 04. 2016	Jul. 03. 2017	1 year
Spectrum Analyzer	R&S	FSP40	100154	Jul. 04. 2016	Jul. 03. 2017	1 year
Horn Antenna	R&S	HF906	10029	Jul. 04. 2016	Jul. 03. 2017	1 year
Amplifier	EM	EM-30180	060538	Jul. 04. 2016	Jul. 03. 2017	1 year

4.5 EUT OPERATING CONDITIONS

The EUT tested system was configured as the statements of **2.3** Unless otherwise a special operating condition is specified in the follows during the testing.

4.6 TEST RESULTS

4.6.1 TEST RESULTS (Bellow 1GHz)

EUT :	WIFI Module	Model Name. :	WCT3EM2611
Temperature :	26 °C	Relative Humidity :	56%
Pressure :	1010hPa	Ant. Pol.:	Horizontal
Test Mode :	WIFI TX Mode (802.11a CH36)		
Test Voltage :	DC 5V		

No.	Mk.	Freq. MHz	Reading Level dBm	Correct Factor dB	Measure- ment dBm	Limit dBm	Over dB	Detector
1	!	36.7900	42.73	-7.25	35.48	40.00	-4.52	peak
2	!	227.8800	56.63	-14.90	41.73	46.00	-4.27	peak
3	!	250.1900	56.19	-13.10	43.09	46.00	-2.91	peak
4	*	298.6900	54.84	-11.61	43.23	46.00	-2.77	peak
5	!	377.2600	51.64	-10.12	41.52	46.00	-4.48	peak
6		710.9400	41.04	-2.87	38.17	46.00	-7.83	peak

Remark:

Factor = Antenna Factor + Cable Loss.

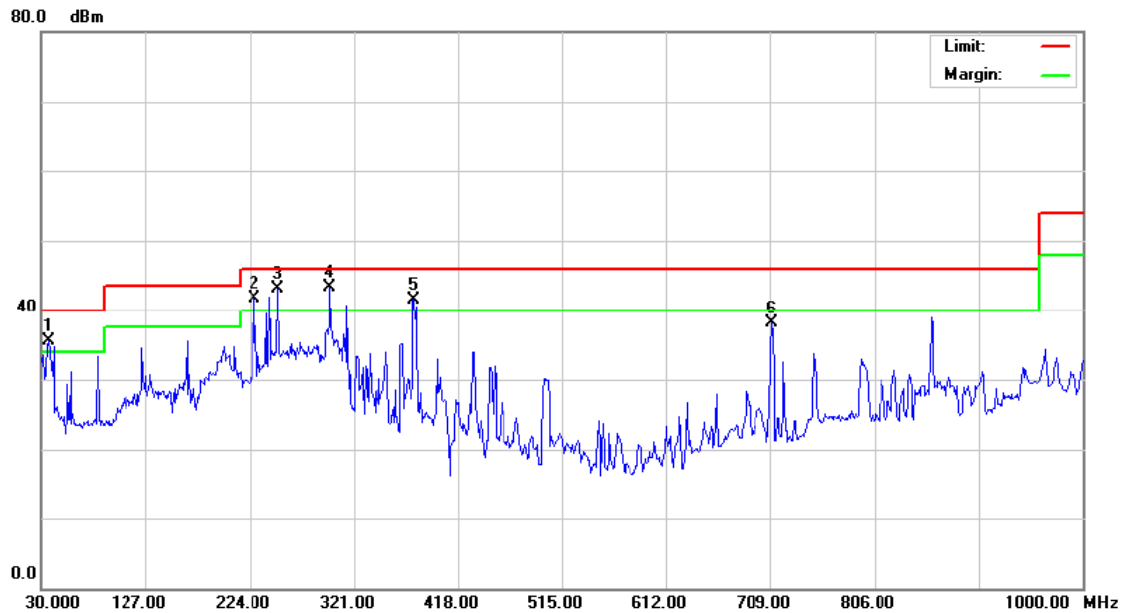

EUT :	WIFI Module	Model Name. :	WCT3EM2611
Temperature :	26 °C	Relative Humidity :	56%
Pressure :	1010hPa	Ant. Pol.:	Vertical
Test Mode :	WIFI TX Mode (802.11a CH36)		
Test Voltage :	DC 5V		

No.	Mk.	Freq. MHz	Reading Level dBm	Correct Factor dB	Measure- ment dBm	Limit dBm	Over dB	Detector
1	!	36.7900	43.52	-7.25	36.27	40.00	-3.73	peak
2	*	242.4300	57.22	-13.44	43.78	46.00	-2.22	peak
3	!	298.6900	54.43	-11.61	42.82	46.00	-3.18	peak
4	!	328.7600	53.03	-11.75	41.28	46.00	-4.72	peak
5	!	377.2600	52.59	-10.12	42.47	46.00	-3.53	peak
6	!	431.5800	50.28	-8.75	41.53	46.00	-4.47	peak

Remark:

Factor = Antenna Factor + Cable Loss.

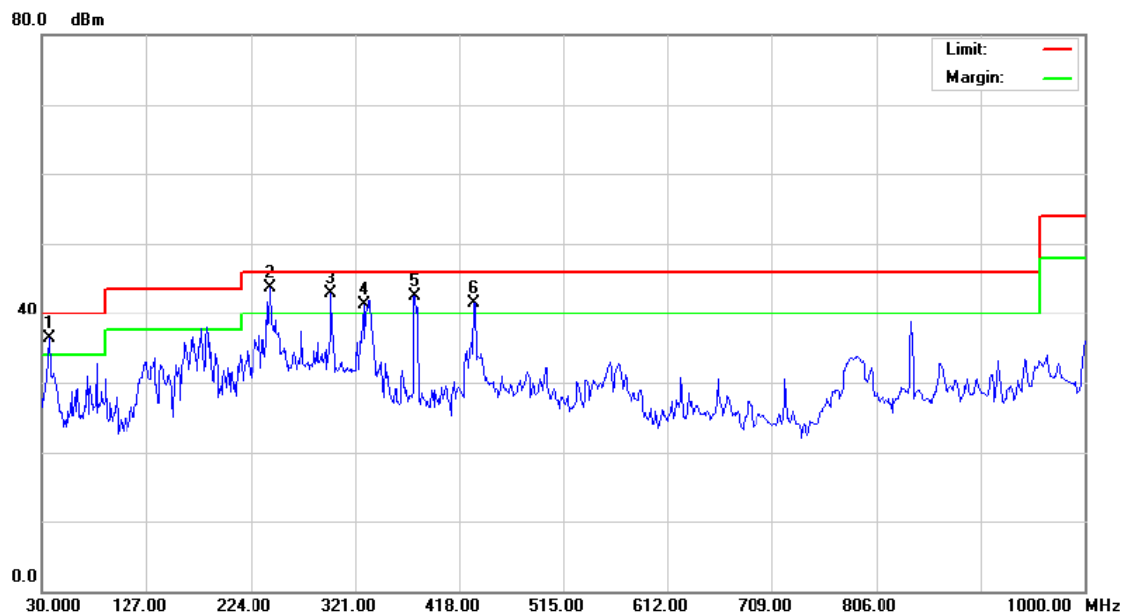

EUT :	WIFI Module	Model Name. :	WCT3EM2611
Temperature :	26 °C	Relative Humidity :	56%
Pressure :	1010hPa	Ant. Pol.:	Horizontal
Test Mode :	WIFI TX Mode (802.11a CH149)		
Test Voltage :	DC 5V		

No.	Mk.	Freq. MHz	Reading Level dBm	Correct Factor dB	Measure- ment dBm	Limit dBm	Over dB	Detector
1		165.8000	50.58	-15.03	35.55	43.50	-7.95	peak
2	!	250.1900	54.69	-13.10	41.59	46.00	-4.41	peak
3	!	298.6900	53.34	-11.61	41.73	46.00	-4.27	peak
4	!	377.2600	51.64	-10.12	41.52	46.00	-4.48	peak
5		710.9400	41.54	-2.87	38.67	46.00	-7.33	peak
6	*	859.3500	42.63	-0.74	41.89	46.00	-4.11	peak

Remark:

Factor = Antenna Factor + Cable Loss.

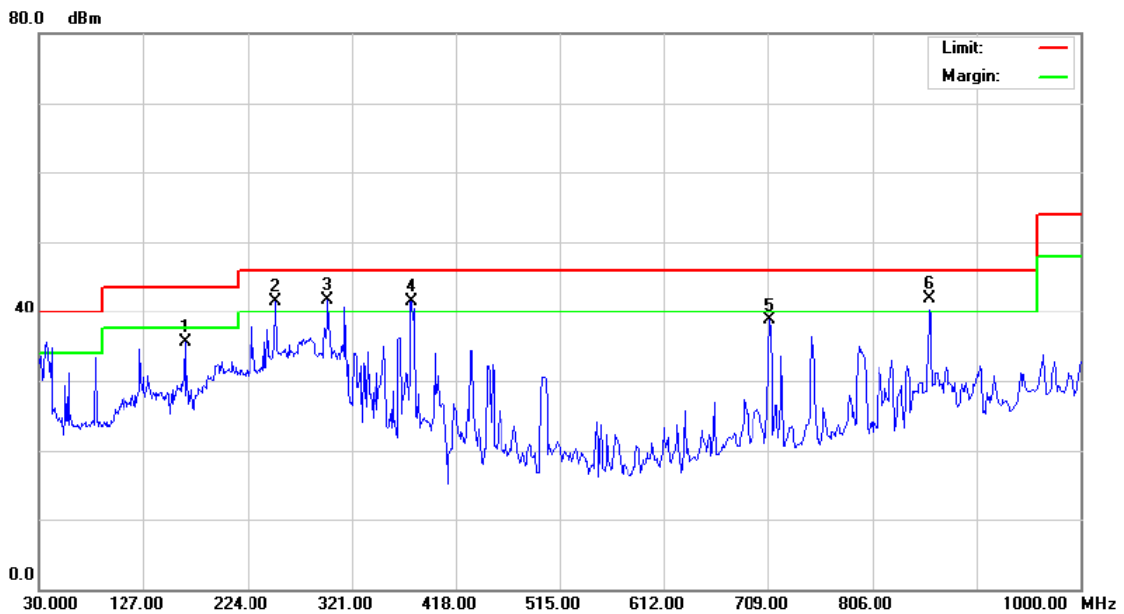

EUT :	WIFI Module	Model Name. :	WCT3EM2611
Temperature :	26 °C	Relative Humidity :	56%
Pressure :	1010hPa	Ant. Pol.:	Vertical
Test Mode :	WIFI TX Mode (802.11a CH149)		
Test Voltage :	DC 5V		

No.	Mk.	Freq. MHz	Reading Level dBuV	Correct Factor dB	Measure- ment dBuV/m	Limit dBuV/m	Over dB	Detector
1		183.8440	56.33	-19.00	37.33	43.50	-6.17	peak
2	!	243.3771	60.22	-18.56	41.66	46.00	-4.34	peak
3	*	299.3158	59.43	-16.73	42.70	46.00	-3.30	peak
4	!	333.6865	58.22	-16.34	41.88	46.00	-4.12	peak
5		377.2590	53.59	-15.92	37.67	46.00	-8.33	peak
6		432.5457	51.78	-15.28	36.50	46.00	-9.50	peak

Remark:

Factor = Antenna Factor + Cable Loss.

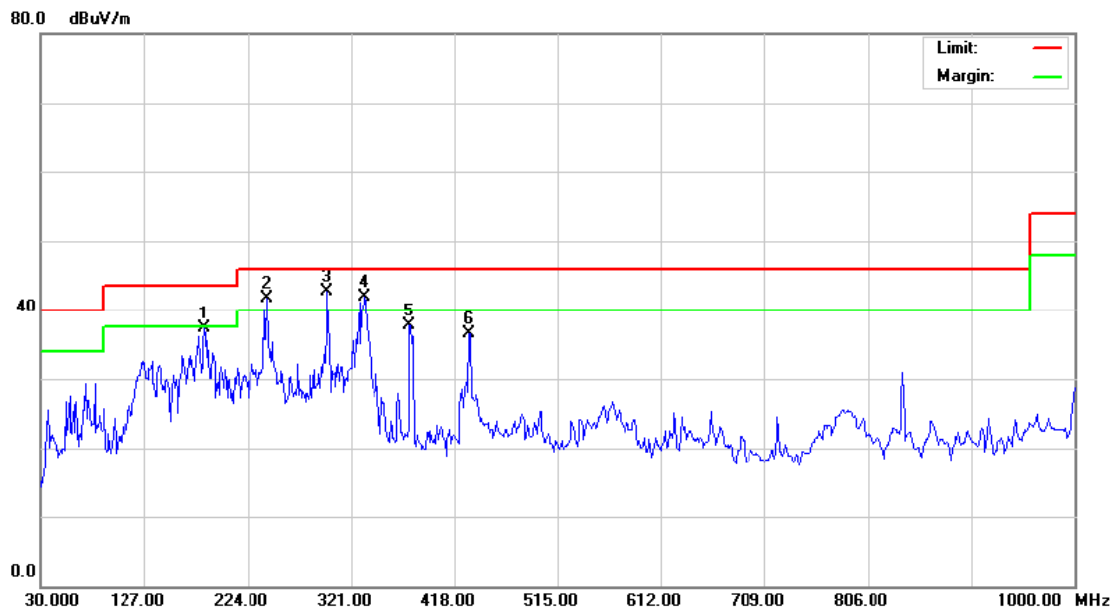

4.6.2 TEST RESULTS (Above 1GHz)

EUT :	WIFI Module	Model Name. :	WCT3EM2611
Temperature :	26 °C	Relative Humidity :	56%
Pressure :	1010hPa	Ant. Pol.:	Horizontal
Test Mode :	WIFI TX Mode (802.11a CH36)		
Test Voltage :	DC 5V		

No. Mk.	Freq.	Reading Level	Correct Factor	Measurement	Limit	Over	Detector	Comment
	MHz	dBuV	dB	dBuV/m	dBuV/m	dB		
1	5150.000	53.86	8.69	62.55	68.30	-5.75	peak	
2	5150.000	41.54	8.69	50.23	54.00	-3.77	AVG	
3 X	5184.200	98.20	8.79	106.99	68.30	38.69	peak	FUNDAMENTAL FREQUENCY
4 *	5186.400	88.63	8.80	97.43	54.00	43.43	AVG	FUNDAMENTAL FREQUENCY

No. Mk.	Freq.	Reading Level	Correct Factor	Measurement	Limit	Over	Detector	Comment
	MHz	dBuV	dB	dBuV/m	dBuV/m	dB		
1 *	10359.87	32.97	15.58	48.55	54.00	-5.45	AVG	
2	10360.45	45.17	15.59	60.76	68.30	-7.54	peak	

Remark:

Factor = Antenna Factor + Cable Loss.

EUT :	WIFI Module	Model Name. :	WCT3EM2611
Temperature :	26 °C	Relative Humidity :	56%
Pressure :	1010hPa	Ant. Pol.:	Vertical
Test Mode :	WIFI TX Mode (802.11a CH36)		
Test Voltage :	DC 5V		

No. Mk.	Freq.	Reading Level	Correct Factor	Measurement	Limit	Over	Detector	Comment
	MHz	dBuV	dB	dBuV/m	dBuV/m	dB		
1	5150.000	53.89	8.69	62.58	68.30	-5.72	peak	
2	5150.000	40.43	8.69	49.12	54.00	-4.88	AVG	
3 X	5174.000	97.14	8.76	105.90	68.30	37.60	peak	FUNDAMENTAL FREQUENCY
4 *	5175.000	87.88	8.76	96.64	54.00	42.64	AVG	FUNDAMENTAL FREQUENCY

No. Mk.	Freq.	Reading Level	Correct Factor	Measurement	Limit	Over	Detector	Comment
	MHz	dBuV	dB	dBuV/m	dBuV/m	dB		
1 *	10359.87	32.97	15.58	48.55	54.00	-5.45	AVG	
2	10361.00	45.08	15.60	60.68	68.30	-7.62	peak	

Remark:

Factor = Antenna Factor + Cable Loss.

EUT :	WIFI Module	Model Name. :	WCT3EM2611
Temperature :	26 °C	Relative Humidity :	56%
Pressure :	1010hPa	Ant. Pol.:	Horizontal
Test Mode :	WIFI TX Mode (802.11a CH40)		
Test Voltage :	DC 5V		

No. Mk.	Freq.	Reading Level	Correct Factor	Measurement	Limit	Over	Detector	Comment
	MHz	dBuV	dB	dBuV/m	dBuV/m	dB		
1	10399.66	43.91	15.66	59.57	68.30	-8.73	peak	
2 *	10400.67	32.12	15.66	47.78	54.00	-6.22	AVG	

Remark:

Factor = Antenna Factor + Cable Loss.

EUT :	WIFI Module	Model Name. :	WCT3EM2611
Temperature :	26 °C	Relative Humidity :	56%
Pressure :	1010hPa	Ant. Pol.:	Vertical
Test Mode :	WIFI TX Mode (802.11a CH40)		
Test Voltage :	DC 5V		

No. Mk.	Freq.	Reading Level	Correct Factor	Measurement	Limit	Over	Detector	Comment
	MHz	dBuV	dB	dBuV/m	dBuV/m	dB		
1	10399.46	43.74	15.66	59.40	68.30	-8.90	peak	
2 *	10399.87	31.98	15.66	47.64	54.00	-6.36	AVG	

Remark:

Factor = Antenna Factor + Cable Loss.

EUT :	WIFI Module	Model Name. :	WCT3EM2611
Temperature :	26 °C	Relative Humidity :	56%
Pressure :	1010hPa	Ant. Pol.:	Horizontal
Test Mode :	WIFI TX Mode (802.11a CH48)		
Test Voltage :	DC 5V		

No. Mk.	Freq.	Reading Level	Correct Factor	Measurement	Limit	Over	Detector	Comment
	MHz	dBuV	dB	dBuV/m	dBuV/m	dB		
1 *	5235.000	87.83	8.93	96.76	54.00	42.76	AVG	FUNDAMENTAL FREQUENCY
2 X	5245.200	97.09	8.96	106.05	68.30	37.75	peak	FUNDAMENTAL FREQUENCY
3	5350.000	45.70	9.08	54.78	68.30	-13.52	peak	
4	5350.000	34.96	9.08	44.04	54.00	-9.96	AVG	

No. Mk.	Freq.	Reading Level	Correct Factor	Measurement	Limit	Over	Detector	Comment
	MHz	dBuV	dB	dBuV/m	dBuV/m	dB		
1 *	10479.95	31.97	15.79	47.76	54.00	-6.24	AVG	
2	10480.16	43.29	15.79	59.08	68.30	-9.22	peak	

Remark:

Factor = Antenna Factor + Cable Loss.

EUT :	WIFI Module	Model Name. :	WCT3EM2611
Temperature :	26 °C	Relative Humidity :	56%
Pressure :	1010hPa	Ant. Pol.:	Vertical
Test Mode :	WIFI TX Mode (802.11a CH48)		
Test Voltage :	DC 5V		

No. Mk.	Freq.	Reading Level	Correct Factor	Measurement	Limit	Over	Detector	Comment
	MHz	dBuV	dB	dBuV/m	dBuV/m	dB		
1 X	5246.400	97.76	8.96	106.72	68.30	38.42	peak	FUNDAMENTAL FREQUENCY
2 *	5246.400	88.26	8.96	97.22	54.00	43.22	AVG	FUNDAMENTAL FREQUENCY
3	5350.000	45.80	9.08	54.88	68.30	-13.42	peak	
4	5350.000	34.26	9.08	43.34	54.00	-10.66	AVG	

No. Mk.	Freq.	Reading Level	Correct Factor	Measurement	Limit	Over	Detector	Comment
	MHz	dBuV	dB	dBuV/m	dBuV/m	dB		
1 *	10479.79	32.35	15.79	48.14	54.00	-5.86	AVG	
2	10480.45	44.07	15.79	59.86	68.30	-8.44	peak	

Remark:

Factor = Antenna Factor + Cable Loss.

EUT :	WIFI Module	Model Name. :	WCT3EM2611
Temperature :	26 °C	Relative Humidity :	56%
Pressure :	1010hPa	Ant. Pol.:	Horizontal
Test Mode :	WIFI TX Mode (802.11n(HT20) CH36)		
Test Voltage :	DC 5V		

No. Mk.	Freq.	Reading Level	Correct Factor	Measurement	Limit	Over	Detector	Comment
	MHz	dBuV	dB	dBuV/m	dBuV/m	dB		
1	5150.000	50.84	8.69	59.53	68.30	-8.77	peak	
2	5150.000	39.25	8.69	47.94	54.00	-6.06	AVG	
3 X	5174.200	97.60	8.76	106.36	68.30	38.06	peak	FUNDAMENTAL FREQUENCY
4 *	5185.400	87.86	8.79	96.65	54.00	42.65	AVG	FUNDAMENTAL FREQUENCY

No. Mk.	Freq.	Reading Level	Correct Factor	Measurement	Limit	Over	Detector	Comment
	MHz	dBuV	dB	dBuV/m	dBuV/m	dB		
1 *	10359.70	32.22	15.58	47.80	54.00	-6.20	AVG	
2	10360.84	44.36	15.60	59.96	68.30	-8.34	peak	

Remark:

Factor = Antenna Factor + Cable Loss.

EUT :	WIFI Module	Model Name. :	WCT3EM2611
Temperature :	26 °C	Relative Humidity :	56%
Pressure :	1010hPa	Ant. Pol.:	Vertical
Test Mode :	WIFI TX Mode (802.11n(HT20) CH36)		
Test Voltage :	DC 5V		

No. Mk.	Freq.	Reading Level	Correct Factor	Measurement	Limit	Over	Detector	Comment
	MHz	dBuV	dB	dBuV/m	dBuV/m	dB		
1	5150.000	50.53	8.69	59.22	68.30	-9.08	peak	
2	5150.000	37.83	8.69	46.52	54.00	-7.48	AVG	
3 *	5173.800	87.10	8.76	95.86	54.00	41.86	AVG	FUNDAMENTAL FREQUENCY
4 X	5183.800	97.29	8.79	106.08	68.30	37.78	peak	FUNDAMENTAL FREQUENCY

No. Mk.	Freq.	Reading Level	Correct Factor	Measurement	Limit	Over	Detector	Comment
	MHz	dBuV	dB	dBuV/m	dBuV/m	dB		
1 *	10359.90	32.40	15.58	47.98	54.00	-6.02	AVG	
2	10360.75	44.00	15.60	59.60	68.30	-8.70	peak	

Remark:

Factor = Antenna Factor + Cable Loss.

EUT :	WIFI Module	Model Name. :	WCT3EM2611
Temperature :	26 °C	Relative Humidity :	56%
Pressure :	1010hPa	Ant. Pol.:	Horizontal
Test Mode :	WIFI TX Mode (802.11n(HT20) CH40)		
Test Voltage :	DC 5V		

No. Mk.	Freq.	Reading Level	Correct Factor	Measurement	Limit	Over	Detector	Comment
	MHz	dBuV	dB	dBuV/m	dBuV/m	dB		
1	10399.76	44.01	15.66	59.67	68.30	-8.63	peak	
2 *	10400.45	32.21	15.66	47.87	54.00	-6.13	AVG	

Remark:

Factor = Antenna Factor + Cable Loss.

EUT :	WIFI Module	Model Name. :	WCT3EM2611
Temperature :	26 °C	Relative Humidity :	56%
Pressure :	1010hPa	Ant. Pol.:	Vertical
Test Mode :	WIFI TX Mode (802.11n(HT20) CH40)		
Test Voltage :	DC 5V		

No. Mk.	Freq.	Reading Level	Correct Factor	Measurement	Limit	Over	Detector	Comment
	MHz	dBuV	dB	dBuV/m	dBuV/m	dB		
1	10399.87	43.79	15.66	59.45	68.30	-8.85	peak	
2 *	10400.76	32.19	15.66	47.85	54.00	-6.15	AVG	

Remark:

Factor = Antenna Factor + Cable Loss.

EUT :	WIFI Module	Model Name. :	WCT3EM2611
Temperature :	26 °C	Relative Humidity :	56%
Pressure :	1010hPa	Ant. Pol.:	Horizontal
Test Mode :	WIFI TX Mode (802.11n(HT20) CH48)		
Test Voltage :	DC 5V		

No. Mk.	Freq.	Reading Level	Correct Factor	Measurement	Limit	Over	Detector	Comment
	MHz	dBuV	dB	dBuV/m	dBuV/m	dB		
1 *	5234.000	85.95	8.93	94.88	54.00	40.88	AVG	FUNDAMENTAL FREQUENCY
2 X	5245.600	97.69	8.96	106.65	68.30	38.35	peak	FUNDAMENTAL FREQUENCY
3	5350.000	44.52	9.08	53.60	68.30	-14.70	peak	
4	5350.000	34.78	9.08	43.86	54.00	-10.14	AVG	

No. Mk.	Freq.	Reading Level	Correct Factor	Measurement	Limit	Over	Detector	Comment
	MHz	dBuV	dB	dBuV/m	dBuV/m	dB		
1 *	10479.86	32.47	15.79	48.26	54.00	-5.74	AVG	
2	10480.86	44.27	15.79	60.06	68.30	-8.24	peak	

Remark:
Factor = Antenna Factor + Cable Loss.

EUT :	WIFI Module	Model Name. :	WCT3EM2611
Temperature :	26 °C	Relative Humidity :	56%
Pressure :	1010hPa	Ant. Pol.:	Vertical
Test Mode :	WIFI TX Mode (802.11n(HT20) CH48)		
Test Voltage :	DC 5V		

No. Mk.	Freq.	Reading Level	Correct Factor	Measurement	Limit	Over	Detector	Comment
	MHz	dBuV	dB	dBuV/m	dBuV/m	dB		
1 *	5233.000	86.12	8.93	95.05	54.00	41.05	AVG	FUNDAMENTAL FREQUENCY
2 X	5244.400	96.94	8.96	105.90	68.30	37.60	peak	FUNDAMENTAL FREQUENCY
3	5350.000	45.58	9.08	54.66	68.30	-13.64	peak	
4	5350.000	34.00	9.08	43.08	54.00	-10.92	AVG	

No. Mk.	Freq.	Reading Level	Correct Factor	Measurement	Limit	Over	Detector	Comment
	MHz	dBuV	dB	dBuV/m	dBuV/m	dB		
1	10479.46	44.69	15.79	60.48	68.30	-7.82	peak	
2 *	10480.93	31.86	15.79	47.65	54.00	-6.35	AVG	

Remark:
Factor = Antenna Factor + Cable Loss.

EUT :	WIFI Module	Model Name. :	WCT3EM2611
Temperature :	26 °C	Relative Humidity :	56%
Pressure :	1010hPa	Ant. Pol.:	Horizontal
Test Mode :	WIFI TX Mode (802.11ac(20) CH36)		
Test Voltage :	DC 5V		

No. Mk.	Freq.	Reading Level	Correct Factor	Measurement	Limit	Over	Detector	Comment
	MHz	dBuV	dB	dBuV/m	dBuV/m	dB		
1	5150.000	50.02	8.69	58.71	68.30	-9.59	peak	
2	5150.000	38.73	8.69	47.42	54.00	-6.58	AVG	
3 X	5182.800	98.08	8.78	106.86	68.30	38.56	peak	FUNDAMENTAL FREQUENCY
4 *	5185.600	88.34	8.79	97.13	54.00	43.13	AVG	FUNDAMENTAL FREQUENCY

No. Mk.	Freq.	Reading Level	Correct Factor	Measurement	Limit	Over	Detector	Comment
	MHz	dBuV	dB	dBuV/m	dBuV/m	dB		
1 *	10359.60	31.98	15.58	47.56	54.00	-6.44	AVG	
2	10360.75	44.00	15.60	59.60	68.30	-8.70	peak	

Remark:

Factor = Antenna Factor + Cable Loss.

EUT :	WIFI Module	Model Name. :	WCT3EM2611
Temperature :	26 °C	Relative Humidity :	56%
Pressure :	1010hPa	Ant. Pol.:	Vertical
Test Mode :	WIFI TX Mode (802.11ac(20) CH36)		
Test Voltage :	DC 5V		

No. Mk.	Freq.	Reading Level	Correct Factor	Measurement	Limit	Over	Detector	Comment
	MHz	dBuV	dB	dBuV/m	dBuV/m	dB		
1	5150.000	50.96	8.69	59.65	68.30	-8.65	peak	
2	5150.000	37.76	8.69	46.45	54.00	-7.55	AVG	
3 *	5173.600	87.34	8.76	96.10	54.00	42.10	AVG	FUNDAMENTAL FREQUENCY
4 X	5177.800	97.44	8.77	106.21	68.30	37.91	peak	FUNDAMENTAL FREQUENCY

No. Mk.	Freq.	Reading Level	Correct Factor	Measurement	Limit	Over	Detector	Comment
	MHz	dBuV	dB	dBuV/m	dBuV/m	dB		
1 *	10359.53	32.27	15.58	47.85	54.00	-6.15	AVG	
2	10360.86	44.45	15.60	60.05	68.30	-8.25	peak	

Remark:

Factor = Antenna Factor + Cable Loss.

EUT :	WIFI Module	Model Name. :	WCT3EM2611
Temperature :	26 °C	Relative Humidity :	56%
Pressure :	1010hPa	Ant. Pol.:	Horizontal
Test Mode :	WIFI TX Mode (802.11ac(20) CH40)		
Test Voltage :	DC 5V		

No. Mk.	Freq.	Reading Level	Correct Factor	Measurement	Limit	Over	Detector	Comment
	MHz	dBuV	dB	dBuV/m	dBuV/m	dB		
1	10399.86	31.42	15.66	47.08	54.00	-6.92	AVG	
2 *	10400.75	43.83	15.66	59.49	54.00	5.49	AVG	

Remark:

Factor = Antenna Factor + Cable Loss.

EUT :	WIFI Module	Model Name. :	WCT3EM2611
Temperature :	26 °C	Relative Humidity :	56%
Pressure :	1010hPa	Ant. Pol.:	Vertical
Test Mode :	WIFI TX Mode (802.11ac(20) CH40)		
Test Voltage :	DC 5V		

No. Mk.	Freq.	Reading Level	Correct Factor	Measurement	Limit	Over	Detector	Comment
	MHz	dBuV	dB	dBuV/m	dBuV/m	dB		
1 *	10399.87	32.15	15.66	47.81	54.00	-6.19	AVG	
2	10400.45	44.10	15.66	59.76	68.30	-8.54	peak	

Remark:

Factor = Antenna Factor + Cable Loss.

EUT :	WIFI Module	Model Name. :	WCT3EM2611
Temperature :	26 °C	Relative Humidity :	56%
Pressure :	1010hPa	Ant. Pol.:	Horizontal
Test Mode :	WIFI TX Mode (802.11ac(20) CH48)		
Test Voltage :	DC 5V		

No. Mk.	Freq.	Reading Level	Correct Factor	Measurement	Limit	Over	Detector	Comment
	MHz	dBuV	dB	dBuV/m	dBuV/m	dB		
1 *	5235.800	89.05	8.93	97.98	54.00	43.98	AVG	FUNDAMENTAL FREQUENCY
2 X	5244.800	98.88	8.96	107.84	68.30	39.54	peak	FUNDAMENTAL FREQUENCY
3	5350.000	44.00	9.08	53.08	68.30	-15.22	peak	
4	5350.000	34.71	9.08	43.79	54.00	-10.21	AVG	

No. Mk.	Freq.	Reading Level	Correct Factor	Measurement	Limit	Over	Detector	Comment
	MHz	dBuV	dB	dBuV/m	dBuV/m	dB		
1 *	10480.01	31.73	15.79	47.52	54.00	-6.48	AVG	
2	10480.64	44.23	15.79	60.02	68.30	-8.28	peak	

Remark:

Factor = Antenna Factor + Cable Loss.

EUT :	WIFI Module	Model Name. :	WCT3EM2611
Temperature :	26 °C	Relative Humidity :	56%
Pressure :	1010hPa	Ant. Pol.:	Vertical
Test Mode :	WIFI TX Mode (802.11ac(20) CH48)		
Test Voltage :	DC 5V		

No. Mk.	Freq.	Reading Level	Correct Factor	Measurement	Limit	Over	Detector	Comment
	MHz	dBuV	dB	dBuV/m	dBuV/m	dB		
1 *	5232.600	87.67	8.93	96.60	54.00	42.60	AVG	FUNDAMENTAL FREQUENCY
2 X	5234.800	98.03	8.93	106.96	68.30	38.66	peak	FUNDAMENTAL FREQUENCY
3	5350.000	43.82	9.08	52.90	68.30	-15.40	peak	
4	5350.000	34.61	9.08	43.69	54.00	-10.31	AVG	

No. Mk.	Freq.	Reading Level	Correct Factor	Measurement	Limit	Over	Detector	Comment
	MHz	dBuV	dB	dBuV/m	dBuV/m	dB		
1 *	10479.98	31.11	15.79	46.90	54.00	-7.10	AVG	
2	10480.84	44.09	15.79	59.88	68.30	-8.42	peak	

Remark:

Factor = Antenna Factor + Cable Loss.

EUT :	WIFI Module	Model Name. :	WCT3EM2611
Temperature :	26 °C	Relative Humidity :	56%
Pressure :	1010hPa	Ant. Pol.:	Horizontal
Test Mode :	WIFI TX Mode (802.11n(HT40) CH38)		
Test Voltage :	DC 5V		

No. Mk.	Freq.	Reading Level	Correct Factor	Measurement	Limit	Over	Detector	Comment
	MHz	dBuV	dB	dBuV/m	dBuV/m	dB		
1	5150.000	48.39	8.69	57.08	68.30	-11.22	peak	
2	5150.000	36.90	8.69	45.59	54.00	-8.41	AVG	
3 X	5176.800	93.31	8.77	102.08	68.30	33.78	peak	FUNDAMENTAL FREQUENCY
4 *	5188.200	82.61	8.80	91.41	54.00	37.41	AVG	FUNDAMENTAL FREQUENCY

No. Mk.	Freq.	Reading Level	Correct Factor	Measurement	Limit	Over	Detector	Comment
	MHz	dBuV	dB	dBuV/m	dBuV/m	dB		
1 *	10379.77	31.56	15.61	47.17	54.00	-6.83	AVG	
2	10380.79	44.44	15.62	60.06	68.30	-8.24	peak	

Remark:

Factor = Antenna Factor + Cable Loss.

EUT :	WIFI Module	Model Name. :	WCT3EM2611
Temperature :	26 °C	Relative Humidity :	56%
Pressure :	1010hPa	Ant. Pol.:	Vertical
Test Mode :	WIFI TX Mode (802.11n(HT40) CH38)		
Test Voltage :	DC 5V		

No. Mk.	Freq.	Reading Level	Correct Factor	Measurement	Limit	Over	Detector	Comment
	MHz	dBuV	dB	dBuV/m	dBuV/m	dB		
1	5150.000	48.01	8.69	56.70	68.30	-11.60	peak	
2	5150.000	36.91	8.69	45.60	54.00	-8.40	AVG	
3 *	5188.400	82.53	8.80	91.33	54.00	37.33	AVG	FUNDAMENTAL FREQUENCY
4 X	5192.000	93.30	8.81	102.11	68.30	33.81	peak	FUNDAMENTAL FREQUENCY

No. Mk.	Freq.	Reading Level	Correct Factor	Measurement	Limit	Over	Detector	Comment
	MHz	dBuV	dB	dBuV/m	dBuV/m	dB		
1 *	10379.50	31.99	15.61	47.60	54.00	-6.40	AVG	
2	10380.64	43.75	15.62	59.37	68.30	-8.93	peak	

Remark:

Factor = Antenna Factor + Cable Loss.

EUT :	WIFI Module	Model Name. :	WCT3EM2611
Temperature :	26 °C	Relative Humidity :	56%
Pressure :	1010hPa	Ant. Pol.:	Horizontal
Test Mode :	WIFI TX Mode (802.11n(HT40) CH46)		
Test Voltage :	DC 5V		

No. Mk.	Freq.	Reading Level	Correct Factor	Measurement	Limit	Over	Detector	Comment
	MHz	dBuV	dB	dBuV/m	dBuV/m	dB		
1 X	5214.400	95.34	8.87	104.21	68.30	35.91	peak	FUNDAMENTAL FREQUENCY
2 *	5228.200	85.14	8.92	94.06	54.00	40.06	AVG	FUNDAMENTAL FREQUENCY
3	5350.000	44.79	9.08	53.87	68.30	-14.43	peak	
4	5350.000	34.47	9.08	43.55	54.00	-10.45	AVG	

No. Mk.	Freq.	Reading Level	Correct Factor	Measurement	Limit	Over	Detector	Comment
	MHz	dBuV	dB	dBuV/m	dBuV/m	dB		
1 *	10459.65	32.16	15.76	47.92	54.00	-6.08	AVG	
2	10460.74	44.00	15.76	59.76	68.30	-8.54	peak	

Remark:

Factor = Antenna Factor + Cable Loss.

EUT :	WIFI Module	Model Name. :	WCT3EM2611
Temperature :	26 °C	Relative Humidity :	56%
Pressure :	1010hPa	Ant. Pol.:	Vertical
Test Mode :	WIFI TX Mode (802.11n(HT40) CH46)		
Test Voltage :	DC 5V		

No. Mk.	Freq.	Reading Level	Correct Factor	Measurement	Limit	Over	Detector	Comment
	MHz	dBuV	dB	dBuV/m	dBuV/m	dB		
1 *	5231.600	85.37	8.92	94.29	54.00	40.29	AVG	FUNDAMENTAL FREQUENCY
2 X	5243.000	95.91	8.96	104.87	68.30	36.57	peak	FUNDAMENTAL FREQUENCY
3	5350.000	44.48	9.08	53.56	68.30	-14.74	peak	
4	5350.000	33.25	9.08	42.33	54.00	-11.67	AVG	

No. Mk.	Freq.	Reading Level	Correct Factor	Measurement	Limit	Over	Detector	Comment
	MHz	dBuV	dB	dBuV/m	dBuV/m	dB		
1 *	10459.86	31.93	15.76	47.69	54.00	-6.31	AVG	
2	10460.50	43.94	15.76	59.70	68.30	-8.60	peak	

Remark:

Factor = Antenna Factor + Cable Loss.

EUT :	WIFI Module	Model Name. :	WCT3EM2611
Temperature :	26 °C	Relative Humidity :	56%
Pressure :	1010hPa	Ant. Pol.:	Horizontal
Test Mode :	WIFI TX Mode (802.11ac(40) CH38)		
Test Voltage :	DC 5V		

No. Mk.	Freq.	Reading Level	Correct Factor	Measurement	Limit	Over	Detector	Comment
	MHz	dBuV	dB	dBuV/m	dBuV/m	dB		
1	5150.000	50.93	8.69	59.62	68.30	-8.68	peak	
2	5150.000	39.54	8.69	48.23	54.00	-5.77	AVG	
3 *	5186.800	84.56	8.80	93.36	54.00	39.36	AVG	FUNDAMENTAL FREQUENCY
4 X	5206.400	95.07	8.85	103.92	68.30	35.62	peak	FUNDAMENTAL FREQUENCY

No. Mk.	Freq.	Reading Level	Correct Factor	Measurement	Limit	Over	Detector	Comment
	MHz	dBuV	dB	dBuV/m	dBuV/m	dB		
1 *	10379.70	33.36	15.61	48.97	54.00	-5.03	AVG	
2	10380.69	44.18	15.62	59.80	68.30	-8.50	peak	

Remark:

Factor = Antenna Factor + Cable Loss.

EUT :	WIFI Module	Model Name. :	WCT3EM2611
Temperature :	26 °C	Relative Humidity :	56%
Pressure :	1010hPa	Ant. Pol.:	Vertical
Test Mode :	WIFI TX Mode (802.11ac(40) CH38)		
Test Voltage :	DC 5V		

No. Mk.	Freq.	Reading Level	Correct Factor	Measurement	Limit	Over	Detector	Comment
	MHz	dBuV	dB	dBuV/m	dBuV/m	dB		
1	5150.000	50.00	8.69	58.69	68.30	-9.61	peak	
2	5150.000	38.68	8.69	47.37	68.30	-20.93	peak	
3 *	5188.200	83.69	8.80	92.49	54.00	38.49	AVG	FUNDAMENTAL FREQUENCY
4 X	5192.000	94.50	8.81	103.31	68.30	35.01	peak	FUNDAMENTAL FREQUENCY

No. Mk.	Freq.	Reading Level	Correct Factor	Measurement	Limit	Over	Detector	Comment
	MHz	dBuV	dB	dBuV/m	dBuV/m	dB		
1 *	10379.45	31.84	15.61	47.45	54.00	-6.55	AVG	
2	10380.64	43.30	15.62	58.92	68.30	-9.38	peak	

Remark:

Factor = Antenna Factor + Cable Loss.

EUT :	WIFI Module	Model Name. :	WCT3EM2611
Temperature :	26 °C	Relative Humidity :	56%
Pressure :	1010hPa	Ant. Pol.:	Horizontal
Test Mode :	WIFI TX Mode (802.11ac(40) CH46)		
Test Voltage :	DC 5V		

No. Mk.	Freq.	Reading Level	Correct Factor	Measurement	Limit	Over	Detector	Comment
	MHz	dBuV	dB	dBuV/m	dBuV/m	dB		
1 *	5226.600	85.41	8.90	94.31	54.00	40.31	AVG	FUNDAMENTAL FREQUENCY
2 X	5231.600	95.97	8.92	104.89	68.30	36.59	peak	FUNDAMENTAL FREQUENCY
3	5350.000	45.00	9.08	54.08	68.30	-14.22	peak	
4	5350.000	34.19	9.08	43.27	54.00	-10.73	AVG	

No. Mk.	Freq.	Reading Level	Correct Factor	Measurement	Limit	Over	Detector	Comment
	MHz	dBuV	dB	dBuV/m	dBuV/m	dB		
1 *	10459.91	31.83	15.76	47.59	54.00	-6.41	AVG	
2	10460.12	44.11	15.76	59.87	68.30	-8.43	peak	

Remark:

Factor = Antenna Factor + Cable Loss.

EUT :	WIFI Module	Model Name. :	WCT3EM2611
Temperature :	26 °C	Relative Humidity :	56%
Pressure :	1010hPa	Ant. Pol.:	Vertical
Test Mode :	WIFI TX Mode (802.11ac(40) CH46)		
Test Voltage :	DC 5V		

No. Mk.	Freq.	Reading Level	Correct Factor	Measurement	Limit	Over	Detector	Comment
	MHz	dBuV	dB	dBuV/m	dBuV/m	dB		
1 *	5228.200	85.31	8.92	94.23	54.00	40.23	AVG	FUNDAMENTAL FREQUENCY
2 X	5235.200	95.72	8.93	104.65	68.30	36.35	peak	FUNDAMENTAL FREQUENCY
3	5350.000	45.61	9.08	54.69	68.30	-13.61	peak	
4	5350.000	34.07	9.08	43.15	54.00	-10.85	AVG	

No. Mk.	Freq.	Reading Level	Correct Factor	Measurement	Limit	Over	Detector	Comment
	MHz	dBuV	dB	dBuV/m	dBuV/m	dB		
1 *	10459.78	31.74	15.76	47.50	54.00	-6.50	AVG	
2	10460.74	43.91	15.76	59.67	68.30	-8.63	peak	

Remark:

Factor = Antenna Factor + Cable Loss.

EUT :	WIFI Module	Model Name. :	WCT3EM2611
Temperature :	26 °C	Relative Humidity :	56%
Pressure :	1010hPa	Ant. Pol.:	Horizontal
Test Mode :	WIFI TX Mode (802.11ac(80) CH42)		
Test Voltage :	DC 5V		

No. Mk.	Freq.	Reading Level	Correct Factor	Measurement	Limit	Over	Detector	Comment
	MHz	dBuV	dB	dBuV/m	dBuV/m	dB		
1	5150.000	54.19	8.69	62.88	68.30	-5.42	peak	
2	5150.000	40.29	8.69	48.98	54.00	-5.02	AVG	
3 X	5219.400	92.14	8.89	101.03	68.30	32.73	peak	FUNDAMENTAL FREQUENCY
4 *	5237.200	82.83	8.93	91.76	54.00	37.76	AVG	FUNDAMENTAL FREQUENCY
3	5350.000	45.98	9.08	55.06	68.30	-13.24	peak	
4	5350.000	35.02	9.08	44.10	54.00	-9.90	AVG	

No. Mk.	Freq.	Reading Level	Correct Factor	Measurement	Limit	Over	Detector	Comment
	MHz	dBuV	dB	dBuV/m	dBuV/m	dB		
1	10419.65	44.98	15.69	60.67	68.30	-7.63	peak	
2 *	10420.14	32.61	15.69	48.30	54.00	-5.70	AVG	

Remark:

Factor = Antenna Factor + Cable Loss.

EUT :	WIFI Module	Model Name. :	WCT3EM2611
Temperature :	26 °C	Relative Humidity :	56%
Pressure :	1010hPa	Ant. Pol.:	Vertical
Test Mode :	WIFI TX Mode (802.11ac(80) CH42)		
Test Voltage :	DC 5V		

No. Mk.	Freq.	Reading Level	Correct Factor	Measurement	Limit	Over	Detector	Comment
	MHz	dBuV	dB	dBuV/m	dBuV/m	dB		
1	5150.000	48.90	8.69	57.59	68.30	-10.71	peak	
2	5150.000	38.01	8.69	46.70	54.00	-7.30	AVG	
3 *	5228.000	82.74	8.92	91.66	54.00	37.66	AVG	FUNDAMENTAL FREQUENCY
4 X	5236.800	92.93	8.93	101.86	68.30	33.56	peak	FUNDAMENTAL FREQUENCY
3	5350.000	45.70	9.08	54.78	68.30	-13.52	peak	
4	5350.000	34.97	9.08	44.05	54.00	-9.95	AVG	

No. Mk.	Freq.	Reading Level	Correct Factor	Measurement	Limit	Over	Detector	Comment
	MHz	dBuV	dB	dBuV/m	dBuV/m	dB		
1	10419.86	44.18	15.69	59.87	68.30	-8.43	peak	
2 *	10420.68	32.53	15.69	48.22	54.00	-5.78	AVG	

Remark:

Factor = Antenna Factor + Cable Loss.

EUT :	WIFI Module	Model Name. :	WCT3EM2611
Temperature :	26 °C	Relative Humidity :	56%
Pressure :	1010hPa	Ant. Pol.:	Horizontal
Test Mode :	WIFI TX Mode (802.11a CH149)		
Test Voltage :	DC 5V		

No. Mk.	Freq.	Reading Level	Correct Factor	Measurement	Limit	Over	Detector	Comment
	MHz	dBuV	dB	dBuV/m	dBuV/m	dB		
1	5725.000	49.20	9.78	58.98	68.30	-9.32	peak	
2	5725.000	37.66	9.78	47.44	54.00	-6.56	AVG	
3 *	5740.200	84.59	9.83	94.42	54.00	40.42	AVG	FUNDAMENTAL FREQUENCY
4 X	5741.000	94.87	9.83	104.70	68.30	36.40	peak	FUNDAMENTAL FREQUENCY

No. Mk.	Freq.	Reading Level	Correct Factor	Measurement	Limit	Over	Detector	Comment
	MHz	dBuV	dB	dBuV/m	dBuV/m	dB		
1 *	11489.87	32.57	16.64	49.21	54.00	-4.79	AVG	
2	11490.89	44.16	16.64	60.80	68.30	-7.50	peak	

Remark:

Factor = Antenna Factor + Cable Loss.

EUT :	WIFI Module	Model Name. :	WCT3EM2611
Temperature :	26 °C	Relative Humidity :	56%
Pressure :	1010hPa	Ant. Pol.:	Vertical
Test Mode :	WIFI TX Mode (802.11a CH149)		
Test Voltage :	DC 5V		

No. Mk.	Freq.	Reading Level	Correct Factor	Measurement	Limit	Over	Detector	Comment
	MHz	dBuV	dB	dBuV/m	dBuV/m	dB		
1	5725.000	48.78	9.78	58.56	68.30	-9.74	peak	
2	5725.000	36.86	9.78	46.64	54.00	-7.36	AVG	
3 X	5749.200	93.83	9.84	103.67	68.30	35.37	peak	FUNDAMENTAL FREQUENCY
4 *	5751.200	82.65	9.85	92.50	54.00	38.50	AVG	FUNDAMENTAL FREQUENCY

No. Mk.	Freq.	Reading Level	Correct Factor	Measurement	Limit	Over	Detector	Comment
	MHz	dBuV	dB	dBuV/m	dBuV/m	dB		
1 *	11489.61	33.53	16.64	50.17	54.00	-3.83	AVG	
2	11490.87	44.92	16.64	61.56	68.30	-6.74	peak	

Remark:

Factor = Antenna Factor + Cable Loss.

EUT :	WIFI Module	Model Name. :	WCT3EM2611
Temperature :	26 °C	Relative Humidity :	56%
Pressure :	1010hPa	Ant. Pol.:	Horizontal
Test Mode :	WIFI TX Mode (802.11a CH157)		
Test Voltage :	DC 5V		

No.	Mk.	Freq.	Reading Level	Correct Factor	Measurement	Limit	Over	Detector	Comment
		MHz	dBuV	dB	dBuV/m	dBuV/m	dB		
1	*	11569.42	32.79	16.80	49.59	54.00	-4.41	AVG	
2		11570.60	44.07	16.80	60.87	68.30	-7.43	peak	

Remark:

Factor = Antenna Factor + Cable Loss.

EUT :	WIFI Module	Model Name. :	WCT3EM2611
Temperature :	26 °C	Relative Humidity :	56%
Pressure :	1010hPa	Ant. Pol.:	Vertical
Test Mode :	WIFI TX Mode (802.11a CH157)		
Test Voltage :	DC 5V		

No.	Mk.	Freq.	Reading Level	Correct Factor	Measurement	Limit	Over	Detector	Comment
		MHz	dBuV	dB	dBuV/m	dBuV/m	dB		
1	*	11569.74	33.60	16.80	50.40	54.00	-3.60	AVG	
2		11570.75	44.79	16.80	61.59	68.30	-6.71	peak	

Remark:

Factor = Antenna Factor + Cable Loss.

EUT :	WIFI Module	Model Name. :	WCT3EM2611
Temperature :	26 °C	Relative Humidity :	56%
Pressure :	1010hPa	Ant. Pol.:	Horizontal
Test Mode :	WIFI TX Mode (802.11a CH165)		
Test Voltage :	DC 5V		

No. Mk.	Freq.	Reading Level	Correct Factor	Measurement	Limit	Over	Detector	Comment
	MHz	dBuV	dB	dBuV/m	dBuV/m	dB		
1 *	5820.000	85.88	10.05	95.93	54.00	41.93	AVG	FUNDAMENTAL FREQUENCY
2 X	5831.200	95.58	10.08	105.66	68.30	37.36	peak	FUNDAMENTAL FREQUENCY
3	5850.000	49.74	10.13	59.87	68.30	-8.43	peak	
4	5850.000	38.48	10.13	48.61	54.00	-5.39	AVG	

No. Mk.	Freq.	Reading Level	Correct Factor	Measurement	Limit	Over	Detector	Comment
	MHz	dBuV	dB	dBuV/m	dBuV/m	dB		
1 *	11649.94	32.71	16.99	49.70	54.00	-4.30	AVG	
2	11651.16	43.30	16.99	60.29	68.30	-8.01	peak	

Remark:

Factor = Antenna Factor + Cable Loss.

EUT :	WIFI Module	Model Name. :	WCT3EM2611
Temperature :	26 °C	Relative Humidity :	56%
Pressure :	1010hPa	Ant. Pol.:	Vertical
Test Mode :	WIFI TX Mode (802.11a CH165)		
Test Voltage :	DC 5V		

No. Mk.	Freq.	Reading Level	Correct Factor	Measurement	Limit	Over	Detector	Comment
	MHz	dBuV	dB	dBuV/m	dBuV/m	dB		
1 X	5821.200	94.44	10.05	104.49	68.30	36.19	peak	FUNDAMENTAL FREQUENCY
2 *	5831.200	84.44	10.08	94.52	54.00	40.52	AVG	FUNDAMENTAL FREQUENCY
3	5850.000	49.54	10.13	59.67	68.30	-8.63	peak	
4	5850.000	37.06	10.13	47.19	54.00	-6.81	AVG	

No. Mk.	Freq.	Reading Level	Correct Factor	Measurement	Limit	Over	Detector	Comment
	MHz	dBuV	dB	dBuV/m	dBuV/m	dB		
1 *	11649.57	33.74	16.99	50.73	54.00	-3.27	AVG	
2	11650.68	44.20	16.99	61.19	68.30	-7.11	peak	

Remark:

Factor = Antenna Factor + Cable Loss.

EUT :	WIFI Module	Model Name. :	WCT3EM2611
Temperature :	26 °C	Relative Humidity :	56%
Pressure :	1010hPa	Ant. Pol.:	Horizontal
Test Mode :	WIFI TX Mode (802.11n(HT20) CH149)		
Test Voltage :	DC 5V		

No. Mk.	Freq.	Reading Level	Correct Factor	Measurement	Limit	Over	Detector	Comment
	MHz	dBuV	dB	dBuV/m	dBuV/m	dB		
1	5725.000	49.47	9.78	59.25	68.30	-9.05	peak	
2	5725.000	38.21	9.78	47.99	54.00	-6.01	AVG	
3 *	5740.400	82.72	9.83	92.55	54.00	38.55	AVG	FUNDAMENTAL FREQUENCY
4 X	5751.200	93.59	9.85	103.44	68.30	35.14	peak	FUNDAMENTAL FREQUENCY

No. Mk.	Freq.	Reading Level	Correct Factor	Measurement	Limit	Over	Detector	Comment
	MHz	dBuV	dB	dBuV/m	dBuV/m	dB		
1 *	11489.86	32.26	16.64	48.90	54.00	-5.10	AVG	
2	11490.60	43.09	16.64	59.73	68.30	-8.57	peak	

Remark:

Factor = Antenna Factor + Cable Loss.

EUT :	WIFI Module	Model Name. :	WCT3EM2611
Temperature :	26 °C	Relative Humidity :	56%
Pressure :	1010hPa	Ant. Pol.:	Vertical
Test Mode :	WIFI TX Mode (802.11n(HT20) CH149)		
Test Voltage :	DC 5V		

No. Mk.	Freq.	Reading Level	Correct Factor	Measurement	Limit	Over	Detector	Comment
	MHz	dBuV	dB	dBuV/m	dBuV/m	dB		
1	5725.000	48.28	9.78	58.06	68.30	-10.24	peak	
2	5725.000	37.19	9.78	46.97	54.00	-7.03	AVG	
3 *	5739.200	80.92	9.82	90.74	54.00	36.74	AVG	FUNDAMENTAL FREQUENCY
4 X	5750.800	91.93	9.85	101.78	68.30	33.48	peak	FUNDAMENTAL FREQUENCY

No. Mk.	Freq.	Reading Level	Correct Factor	Measurement	Limit	Over	Detector	Comment
	MHz	dBuV	dB	dBuV/m	dBuV/m	dB		
1 *	11489.86	32.26	16.64	48.90	54.00	-5.10	AVG	
2	11490.60	43.09	16.64	59.73	68.30	-8.57	peak	

Remark:

Factor = Antenna Factor + Cable Loss.

EUT :	WIFI Module	Model Name. :	WCT3EM2611
Temperature :	26 °C	Relative Humidity :	56%
Pressure :	1010hPa	Ant. Pol.:	Horizontal
Test Mode :	WIFI TX Mode (802.11n(HT20) CH157)		
Test Voltage :	DC 5V		

No. Mk.	Freq.	Reading Level	Correct Factor	Measurement	Limit	Over	Detector	Comment
	MHz	dBuV	dB	dBuV/m	dBuV/m	dB		
1 *	11569.92	32.66	16.80	49.46	54.00	-4.54	AVG	
2	11570.78	43.48	16.80	60.28	68.30	-8.02	peak	

Remark:

Factor = Antenna Factor + Cable Loss.

EUT :	WIFI Module	Model Name. :	WCT3EM2611
Temperature :	26 °C	Relative Humidity :	56%
Pressure :	1010hPa	Ant. Pol.:	Vertical
Test Mode :	WIFI TX Mode (802.11n(HT20) CH157)		
Test Voltage :	DC 5V		

No. Mk.	Freq.	Reading Level	Correct Factor	Measurement	Limit	Over	Detector	Comment
	MHz	dBuV	dB	dBuV/m	dBuV/m	dB		
1 *	11569.66	33.64	16.80	50.44	54.00	-3.56	AVG	
2	11570.80	44.07	16.80	60.87	68.30	-7.43	peak	

Remark:

Factor = Antenna Factor + Cable Loss.

EUT :	WIFI Module	Model Name. :	WCT3EM2611
Temperature :	26 °C	Relative Humidity :	56%
Pressure :	1010hPa	Ant. Pol.:	Horizontal
Test Mode :	WIFI TX Mode (802.11n(HT20) CH165)		
Test Voltage :	DC 5V		

No. Mk.	Freq.	Reading Level	Correct Factor	Measurement	Limit	Over	Detector	Comment
	MHz	dBuV	dB	dBuV/m	dBuV/m	dB		
1 X	5819.000	95.54	10.05	105.59	68.30	37.29	peak	FUNDAMENTAL FREQUENCY
2 *	5830.400	85.09	10.08	95.17	54.00	41.17	AVG	FUNDAMENTAL FREQUENCY
3	5850.000	51.43	10.13	61.56	68.30	-6.74	peak	
4	5850.000	39.33	10.13	49.46	54.00	-4.54	AVG	

No. Mk.	Freq.	Reading Level	Correct Factor	Measurement	Limit	Over	Detector	Comment
	MHz	dBuV	dB	dBuV/m	dBuV/m	dB		
1 *	11649.82	31.90	16.99	48.89	54.00	-5.11	AVG	
2	11650.90	43.21	16.99	60.20	68.30	-8.10	peak	

Remark:

Factor = Antenna Factor + Cable Loss.

EUT :	WIFI Module	Model Name. :	WCT3EM2611
Temperature :	26 °C	Relative Humidity :	56%
Pressure :	1010hPa	Ant. Pol.:	Vertical
Test Mode :	WIFI TX Mode (802.11n(HT20) CH165)		
Test Voltage :	DC 5V		

No. Mk.	Freq.	Reading Level	Correct Factor	Measurement	Limit	Over	Detector	Comment
	MHz	dBuV	dB	dBuV/m	dBuV/m	dB		
1 *	5819.600	83.29	10.05	93.34	54.00	39.34	AVG	FUNDAMENTAL FREQUENCY
2 X	5831.200	93.95	10.08	104.03	68.30	35.73	peak	FUNDAMENTAL FREQUENCY
3	5850.000	49.65	10.13	59.78	68.30	-8.52	peak	
4	5850.000	38.43	10.13	48.56	54.00	-5.44	AVG	

No. Mk.	Freq.	Reading Level	Correct Factor	Measurement	Limit	Over	Detector	Comment
	MHz	dBuV	dB	dBuV/m	dBuV/m	dB		
1 *	11649.88	33.09	16.99	50.08	54.00	-3.92	AVG	
2	11650.89	43.90	16.99	60.89	68.30	-7.41	peak	

Remark:

Factor = Antenna Factor + Cable Loss.

EUT :	WIFI Module	Model Name. :	WCT3EM2611
Temperature :	26 °C	Relative Humidity :	56%
Pressure :	1010hPa	Ant. Pol.:	Horizontal
Test Mode :	WIFI TX Mode (802.11ac(20) CH149)		
Test Voltage :	DC 5V		

No. Mk.	Freq.	Reading Level	Correct Factor	Measurement	Limit	Over	Detector	Comment
	MHz	dBuV	dB	dBuV/m	dBuV/m	dB		
1	5725.000	48.64	9.78	58.42	68.30	-9.88	peak	
2	5725.000	38.08	9.78	47.86	54.00	-6.14	AVG	
3 X	5738.600	93.31	9.81	103.12	68.30	34.82	peak	FUNDAMENTAL FREQUENCY
4 *	5751.200	82.48	9.85	92.33	54.00	38.33	AVG	FUNDAMENTAL FREQUENCY

No. Mk.	Freq.	Reading Level	Correct Factor	Measurement	Limit	Over	Detector	Comment
	MHz	dBuV	dB	dBuV/m	dBuV/m	dB		
1 *	11489.58	31.67	16.64	48.31	54.00	-5.69	AVG	
2	11490.93	43.04	16.64	59.68	68.30	-8.62	peak	

Remark:

Factor = Antenna Factor + Cable Loss.

EUT :	WIFI Module	Model Name. :	WCT3EM2611
Temperature :	26 °C	Relative Humidity :	56%
Pressure :	1010hPa	Ant. Pol.:	Vertical
Test Mode :	WIFI TX Mode (802.11ac(20) CH149)		
Test Voltage :	DC 5V		

No. Mk.	Freq.	Reading Level	Correct Factor	Measurement	Limit	Over	Detector	Comment
	MHz	dBuV	dB	dBuV/m	dBuV/m	dB		
1	5725.000	48.40	9.78	58.18	68.30	-10.12	peak	
2	5725.000	37.57	9.78	47.35	54.00	-6.65	AVG	
3 X	5740.200	92.82	9.83	102.65	68.30	34.35	peak	FUNDAMENTAL FREQUENCY
4 *	5751.600	82.03	9.85	91.88	54.00	37.88	AVG	FUNDAMENTAL FREQUENCY

No. Mk.	Freq.	Reading Level	Correct Factor	Measurement	Limit	Over	Detector	Comment
	MHz	dBuV	dB	dBuV/m	dBuV/m	dB		
1 *	11489.67	31.68	16.64	48.32	54.00	-5.68	AVG	
2	11491.23	42.14	16.64	58.78	68.30	-9.52	peak	

Remark:

Factor = Antenna Factor + Cable Loss.

EUT :	WIFI Module	Model Name. :	WCT3EM2611
Temperature :	26 °C	Relative Humidity :	56%
Pressure :	1010hPa	Ant. Pol.:	Horizontal
Test Mode :	WIFI TX Mode (802.11ac(20) CH157)		
Test Voltage :	DC 5V		

No.	Mk.	Freq.	Reading Level	Correct Factor	Measurement	Limit	Over	Detector	Comment
		MHz	dBuV	dB	dBuV/m	dBuV/m	dB		
1	*	11569.37	30.39	16.80	47.19	54.00	-6.81	AVG	
2		11570.68	42.04	16.80	58.84	68.30	-9.46	peak	

Remark:

Factor = Antenna Factor + Cable Loss.

EUT :	WIFI Module	Model Name. :	WCT3EM2611
Temperature :	26 °C	Relative Humidity :	56%
Pressure :	1010hPa	Ant. Pol.:	Vertical
Test Mode :	WIFI TX Mode (802.11ac(20) CH157)		
Test Voltage :	DC 5V		

No.	Mk.	Freq.	Reading Level	Correct Factor	Measurement	Limit	Over	Detector	Comment
		MHz	dBuV	dB	dBuV/m	dBuV/m	dB		
1	*	11569.70	30.79	16.80	47.59	54.00	-6.41	AVG	
2		11570.54	42.18	16.80	58.98	68.30	-9.32	peak	

Remark:

Factor = Antenna Factor + Cable Loss.

EUT :	WIFI Module	Model Name. :	WCT3EM2611
Temperature :	26 °C	Relative Humidity :	56%
Pressure :	1010hPa	Ant. Pol.:	Horizontal
Test Mode :	WIFI TX Mode (802.11ac(20) CH165)		
Test Voltage :	DC 5V		

No. Mk.	Freq.	Reading Level	Correct Factor	Measurement	Limit	Over	Detector	Comment
	MHz	dBuV	dB	dBuV/m	dBuV/m	dB		
1 *	5830.000	84.19	10.08	94.27	54.00	40.27	AVG	FUNDAMENTAL FREQUENCY
2 X	5832.800	94.69	10.08	104.77	68.30	36.47	peak	FUNDAMENTAL FREQUENCY
3	5850.000	49.01	10.13	59.14	68.30	-9.16	peak	
4	5850.000	37.33	10.13	47.46	54.00	-6.54	AVG	

No. Mk.	Freq.	Reading Level	Correct Factor	Measurement	Limit	Over	Detector	Comment
	MHz	dBuV	dB	dBuV/m	dBuV/m	dB		
1 *	11649.67	31.49	16.99	48.48	54.00	-5.52	AVG	
2	11650.86	42.51	16.99	59.50	68.30	-8.80	peak	

Remark:

Factor = Antenna Factor + Cable Loss.

EUT :	WIFI Module	Model Name. :	WCT3EM2611
Temperature :	26 °C	Relative Humidity :	56%
Pressure :	1010hPa	Ant. Pol.:	Vertical
Test Mode :	WIFI TX Mode (802.11ac(20) CH165)		
Test Voltage :	DC 5V		

No. Mk.	Freq.	Reading Level	Correct Factor	Measurement	Limit	Over	Detector	Comment
	MHz	dBuV	dB	dBuV/m	dBuV/m	dB		
1 X	5819.200	93.63	10.05	103.68	68.30	35.38	peak	FUNDAMENTAL FREQUENCY
2 *	5831.400	83.31	10.08	93.39	54.00	39.39	AVG	FUNDAMENTAL FREQUENCY
3	5850.000	50.09	10.13	60.22	68.30	-8.08	peak	
4	5850.000	38.62	10.13	48.75	54.00	-5.25	AVG	

No. Mk.	Freq.	Reading Level	Correct Factor	Measurement	Limit	Over	Detector	Comment
	MHz	dBuV	dB	dBuV/m	dBuV/m	dB		
1 *	11649.60	32.09	16.99	49.08	54.00	-4.92	AVG	
2	11650.75	42.59	16.99	59.58	68.30	-8.72	peak	

Remark:

Factor = Antenna Factor + Cable Loss.

EUT :	WIFI Module	Model Name. :	WCT3EM2611
Temperature :	26 °C	Relative Humidity :	56%
Pressure :	1010hPa	Ant. Pol.:	Horizontal
Test Mode :	WIFI TX Mode (802.11n(HT40) CH151)		
Test Voltage :	DC 5V		

No. Mk.	Freq.	Reading Level	Correct Factor	Measurement	Limit	Over	Detector	Comment
	MHz	dBuV	dB	dBuV/m	dBuV/m	dB		
1	5725.000	49.78	9.78	59.56	68.30	-8.74	peak	
2	5725.000	37.35	9.78	47.13	54.00	-6.87	AVG	
3 X	5741.800	90.89	9.83	100.72	68.30	32.42	peak	FUNDAMENTAL FREQUENCY
4 *	5753.000	80.16	9.86	90.02	54.00	36.02	AVG	FUNDAMENTAL FREQUENCY

No. Mk.	Freq.	Reading Level	Correct Factor	Measurement	Limit	Over	Detector	Comment
	MHz	dBuV	dB	dBuV/m	dBuV/m	dB		
1 *	11509.67	31.64	16.66	48.30	54.00	-5.70	AVG	
2	11510.90	42.87	16.67	59.54	68.30	-8.76	peak	

Remark:

Factor = Antenna Factor + Cable Loss.

EUT :	WIFI Module	Model Name. :	WCT3EM2611
Temperature :	26 °C	Relative Humidity :	56%
Pressure :	1010hPa	Ant. Pol.:	Vertical
Test Mode :	WIFI TX Mode (802.11n(HT40) CH151)		
Test Voltage :	DC 5V		

No. Mk.	Freq.	Reading Level	Correct Factor	Measurement	Limit	Over	Detector	Comment
	MHz	dBuV	dB	dBuV/m	dBuV/m	dB		
1	5725.000	47.72	9.78	57.50	68.30	-10.80	peak	
2	5725.000	37.20	9.78	46.98	54.00	-7.02	AVG	
3 X	5741.400	91.25	9.83	101.08	68.30	32.78	peak	FUNDAMENTAL FREQUENCY
4 *	5752.200	80.86	9.85	90.71	54.00	36.71	AVG	FUNDAMENTAL FREQUENCY

No. Mk.	Freq.	Reading Level	Correct Factor	Measurement	Limit	Over	Detector	Comment
	MHz	dBuV	dB	dBuV/m	dBuV/m	dB		
1 *	11509.94	31.81	16.66	48.47	54.00	-5.53	AVG	
2	11511.20	42.22	16.67	58.89	68.30	-9.41	peak	

Remark:

Factor = Antenna Factor + Cable Loss.

EUT :	WIFI Module	Model Name. :	WCT3EM2611
Temperature :	26 °C	Relative Humidity :	56%
Pressure :	1010hPa	Ant. Pol.:	Horizontal
Test Mode :	WIFI TX Mode (802.11n(HT40) CH159)		
Test Voltage :	DC 5V		

No. Mk.	Freq.	Reading Level	Correct Factor	Measurement	Limit	Over	Detector	Comment
	MHz	dBuV	dB	dBuV/m	dBuV/m	dB		
1 X	5793.000	92.70	9.96	102.66	68.30	34.36	peak	FUNDAMENTAL FREQUENCY
2 *	5796.600	82.05	9.98	92.03	54.00	38.03	AVG	FUNDAMENTAL FREQUENCY
3	5850.000	48.76	10.13	58.89	68.30	-9.41	peak	
4	5850.000	37.83	10.13	47.96	54.00	-6.04	AVG	

No. Mk.	Freq.	Reading Level	Correct Factor	Measurement	Limit	Over	Detector	Comment
	MHz	dBuV	dB	dBuV/m	dBuV/m	dB		
1 *	11590.26	31.74	16.85	48.59	54.00	-5.41	AVG	
2	11591.34	42.89	16.85	59.74	68.30	-8.56	peak	

Remark:

Factor = Antenna Factor + Cable Loss.

EUT :	WIFI Module	Model Name. :	WCT3EM2611
Temperature :	26 °C	Relative Humidity :	56%
Pressure :	1010hPa	Ant. Pol.:	Vertical
Test Mode :	WIFI TX Mode (802.11n(HT40) CH159)		
Test Voltage :	DC 5V		

No. Mk.	Freq.	Reading Level	Correct Factor	Measurement	Limit	Over	Detector	Comment
	MHz	dBuV	dB	dBuV/m	dBuV/m	dB		
1 *	5792.000	81.36	9.96	91.32	54.00	37.32	AVG	FUNDAMENTAL FREQUENCY
2 X	5807.200	92.06	10.02	102.08	68.30	33.78	peak	FUNDAMENTAL FREQUENCY
3	5850.000	38.25	10.13	48.38	68.30	-19.92	peak	
4 X	5850.000	49.19	10.13	59.32	54.00	5.32	AVG	

No. Mk.	Freq.	Reading Level	Correct Factor	Measurement	Limit	Over	Detector	Comment
	MHz	dBuV	dB	dBuV/m	dBuV/m	dB		
1 *	11589.89	32.20	16.85	49.05	54.00	-4.95	AVG	
2	11590.86	42.04	16.85	58.89	68.30	-9.41	peak	

Remark:

Factor = Antenna Factor + Cable Loss.

EUT :	WIFI Module	Model Name. :	WCT3EM2611
Temperature :	26 °C	Relative Humidity :	56%
Pressure :	1010hPa	Ant. Pol.:	Horizontal
Test Mode :	WIFI TX Mode (802.11ac(40) CH151)		
Test Voltage :	DC 5V		

No. Mk.	Freq.	Reading Level	Correct Factor	Measurement	Limit	Over	Detector	Comment
	MHz	dBuV	dB	dBuV/m	dBuV/m	dB		
1	5725.000	49.91	9.78	59.69	68.30	-8.61	peak	
2	5725.000	38.22	9.78	48.00	54.00	-6.00	AVG	
3 *	5751.800	81.39	9.85	91.24	54.00	37.24	AVG	FUNDAMENTAL FREQUENCY
4 X	5758.200	92.02	9.87	101.89	68.30	33.59	peak	FUNDAMENTAL FREQUENCY

No. Mk.	Freq.	Reading Level	Correct Factor	Measurement	Limit	Over	Detector	Comment
	MHz	dBuV	dB	dBuV/m	dBuV/m	dB		
1 *	11509.91	30.98	16.66	47.64	54.00	-6.36	AVG	
2	11510.54	41.83	16.67	58.50	68.30	-9.80	peak	

Remark:

Factor = Antenna Factor + Cable Loss.

EUT :	WIFI Module	Model Name. :	WCT3EM2611
Temperature :	26 °C	Relative Humidity :	56%
Pressure :	1010hPa	Ant. Pol.:	Vertical
Test Mode :	WIFI TX Mode (802.11ac(40) CH151)		
Test Voltage :	DC 5V		

No. Mk.	Freq.	Reading Level	Correct Factor	Measurement	Limit	Over	Detector	Comment
	MHz	dBuV	dB	dBuV/m	dBuV/m	dB		
1	5725.000	48.24	9.78	58.02	68.30	-10.28	peak	
2	5725.000	36.29	9.78	46.07	54.00	-7.93	AVG	
3 *	5751.600	80.23	9.85	90.08	54.00	36.08	AVG	FUNDAMENTAL FREQUENCY
4 X	5758.400	91.25	9.87	101.12	68.30	32.82	peak	FUNDAMENTAL FREQUENCY

No. Mk.	Freq.	Reading Level	Correct Factor	Measurement	Limit	Over	Detector	Comment
	MHz	dBuV	dB	dBuV/m	dBuV/m	dB		
1 *	11509.80	31.41	16.66	48.07	54.00	-5.93	AVG	
2	11510.69	42.88	16.67	59.55	68.30	-8.75	peak	

Remark:

Factor = Antenna Factor + Cable Loss.

EUT :	WIFI Module	Model Name. :	WCT3EM2611
Temperature :	26 °C	Relative Humidity :	56%
Pressure :	1010hPa	Ant. Pol.:	Horizontal
Test Mode :	WIFI TX Mode (802.11ac(40) CH159)		
Test Voltage :	DC 5V		

No. Mk.	Freq.	Reading Level	Correct Factor	Measurement	Limit	Over	Detector	Comment
	MHz	dBuV	dB	dBuV/m	dBuV/m	dB		
1 *	5799.400	81.45	9.98	91.43	54.00	37.43	AVG	FUNDAMENTAL FREQUENCY
2 X	5807.000	91.77	10.01	101.78	68.30	33.48	peak	FUNDAMENTAL FREQUENCY
3	5850.000	50.55	10.13	60.68	68.30	-7.62	peak	
4	5850.000	39.13	10.13	49.26	54.00	-4.74	AVG	

No. Mk.	Freq.	Reading Level	Correct Factor	Measurement	Limit	Over	Detector	Comment
	MHz	dBuV	dB	dBuV/m	dBuV/m	dB		
1 *	11590.12	31.60	16.85	48.45	54.00	-5.55	AVG	
2	11591.51	42.04	16.85	58.89	68.30	-9.41	peak	

Remark:
Factor = Antenna Factor + Cable Loss.

EUT :	WIFI Module	Model Name. :	WCT3EM2611
Temperature :	26 °C	Relative Humidity :	56%
Pressure :	1010hPa	Ant. Pol.:	Vertical
Test Mode :	WIFI TX Mode (802.11ac(40) CH159)		
Test Voltage :	DC 5V		

No. Mk.	Freq.	Reading Level	Correct Factor	Measurement	Limit	Over	Detector	Comment
	MHz	dBuV	dB	dBuV/m	dBuV/m	dB		
1 *	5793.200	79.98	9.96	89.94	54.00	35.94	AVG	FUNDAMENTAL FREQUENCY
2 X	5802.800	90.21	10.00	100.21	68.30	31.91	peak	FUNDAMENTAL FREQUENCY
3	5850.000	48.57	10.13	58.70	68.30	-9.60	peak	
4	5850.000	36.75	10.13	46.88	54.00	-7.12	AVG	

No. Mk.	Freq.	Reading Level	Correct Factor	Measurement	Limit	Over	Detector	Comment
	MHz	dBuV	dB	dBuV/m	dBuV/m	dB		
1 *	11589.67	31.73	16.85	48.58	54.00	-5.42	AVG	
2	11590.89	42.05	16.85	58.90	68.30	-9.40	peak	

Remark:
Factor = Antenna Factor + Cable Loss.

EUT :	WIFI Module	Model Name. :	WCT3EM2611
Temperature :	26 °C	Relative Humidity :	56%
Pressure :	1010hPa	Ant. Pol.:	Horizontal
Test Mode :	WIFI TX Mode (802.11ac(80) CH155)		
Test Voltage :	DC 5V		

No. Mk.	Freq.	Reading Level	Correct Factor	Measurement	Limit	Over	Detector	Comment
	MHz	dBuV	dB	dBuV/m	dBuV/m	dB		
1	5725.000	51.07	9.78	60.85	68.30	-7.45	peak	
2	5725.000	38.18	9.78	47.96	54.00	-6.04	AVG	
3 X	5766.000	90.59	9.89	100.48	68.30	32.18	peak	FUNDAMENTAL FREQUENCY
4 *	5810.800	79.94	10.02	89.96	54.00	35.96	AVG	FUNDAMENTAL FREQUENCY
3	5850.000	48.69	10.13	58.82	68.30	-9.48	peak	
4	5850.000	37.63	10.13	47.76	54.00	-6.24	AVG	

No. Mk.	Freq.	Reading Level	Correct Factor	Measurement	Limit	Over	Detector	Comment
	MHz	dBuV	dB	dBuV/m	dBuV/m	dB		
1 *	11549.76	31.65	16.75	48.40	54.00	-5.60	AVG	
2	11550.85	42.20	16.75	58.95	68.30	-9.35	peak	

Remark:

Factor = Antenna Factor + Cable Loss.

EUT :	WIFI Module	Model Name. :	WCT3EM2611
Temperature :	26 °C	Relative Humidity :	56%
Pressure :	1010hPa	Ant. Pol.:	Vertical
Test Mode :	WIFI TX Mode (802.11ac(80) CH155)		
Test Voltage :	DC 5V		

No. Mk.	Freq.	Reading Level	Correct Factor	Measurement	Limit	Over	Detector	Comment
	MHz	dBuV	dB	dBuV/m	dBuV/m	dB		
1	5725.000	48.78	9.78	58.56	68.30	-9.74	peak	
2	5725.000	36.71	9.78	46.49	54.00	-7.51	AVG	
3 X	5800.600	90.21	9.99	100.20	68.30	31.90	peak	FUNDAMENTAL FREQUENCY
4 *	5802.200	79.82	10.00	89.82	54.00	35.82	AVG	FUNDAMENTAL FREQUENCY
3	5850.000	48.56	10.13	58.69	68.30	-9.61	peak	
4	5850.000	37.05	10.13	47.18	54.00	-6.82	AVG	

No. Mk.	Freq.	Reading Level	Correct Factor	Measurement	Limit	Over	Detector	Comment
	MHz	dBuV	dB	dBuV/m	dBuV/m	dB		
1 *	11549.69	31.76	16.75	48.51	54.00	-5.49	AVG	
2	11550.87	42.20	16.75	58.95	68.30	-9.35	peak	

Remark:

Factor = Antenna Factor + Cable Loss.

5. MAXIMUM CONDUCTED OUTPUT POWER MEASUREMENT

5.1 LIMITS

FCC Part 15.407, subpart E/RSS-247	
Frequency Range (MHz)	Limits
5150~5250	Fixed: 30 dBm (1W) Mobile and Portable: 24 dBm (250mW)
5725~5850	30 dBm (1W)

5.2 TEST PROCEDURE

The measurement is according to section 3 of FCC KDB 789033 D02 General UNII Test Procedures New Rules v01.

The EUT was directly connected to the power meter and antenna output port as show in the block diagram as bellow.

5.3 TEST SETUP

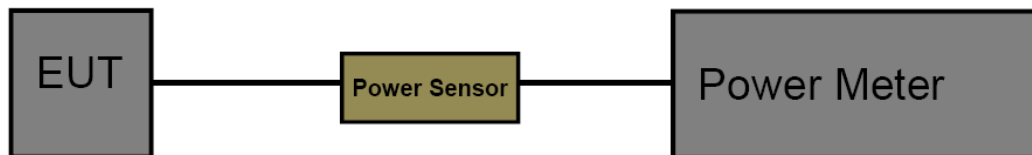

5.4 TEST INSTRUMENTS

Equipment	Manufacturer	Type No.	Serial No.	Last calibration	Calibrated until	Calibration period
P-Series Power Meter	Agilent	N1911A	MY45100482	Jul. 04. 2016	Jul. 03. 2017	1 year
Wideband Power Sensor	Agilent	N1921A	MY51200145	Jul. 04. 2016	Jul. 03. 2017	1 year

5.5 EUT OPERATING CONDITIONS

The EUT was set to continuously transmitting in the maximum power during the test.

5.6 TEST RESULTS

Conducted Power 5150~5250					
802.11a Power					
Channel	Frequency	Conducted Power (dBm)			Max. Limit (dBm)
		Ant. 0	Ant. 1	Total	
36	5180 MHz	15.37		15.37	24
40	5200 MHz	15.69		15.69	
48	5240 MHz	15.92		15.92	
802.11n(HT20) Power					
Channel	Frequency	Conducted Power (dBm)			Max. Limit (dBm)
		Ant. 0	Ant. 1	Total	
36	5180 MHz	12.21	11.05	14.67	24
40	5200 MHz	12.32	11.13	14.77	
48	5240 MHz	12.56	11.30	14.98	
802.11ac(20) Power					
Channel	Frequency	Conducted Power (dBm)			Max. Limit (dBm)
		Ant. 0	Ant. 1	Total	
36	5180 MHz	10.45	9.61	13.06	24
40	5200 MHz	10.56	9.89	13.24	
48	5240 MHz	10.78	9.92	13.38	
802.11n(HT40) Power					
Channel	Frequency	Conducted Power (dBm)			Max. Limit (dBm)
		Ant. 0	Ant. 1	Total	
38	5190 MHz	10.45	9.56	13.03	24
46	5240 MHz	10.88	9.63	13.31	
802.11ac(40) Power					
Channel	Frequency	Conducted Power (dBm)			Max. Limit (dBm)
		Ant. 0	Ant. 1	Total	
38	5190 MHz	10.23	9.18	12.74	24
46	5240 MHz	10.60	9.57	13.12	
802.11ac(80) Power					
Channel	Frequency	Conducted Power (dBm)			Max. Limit (dBm)
		Ant. 0	Ant. 1	Total	
42	5210 MHz	10.65	9.88	13.29	24
Note: The Antenna Gain is -1.0 dBi					

Conducted Power 5725~5850					
802.11a Power					
Channel	Frequency	Conducted Power (dBm)			Max. Limit (dBm)
		Ant. 0	Ant. 1	Total	
149	5745 MHz	14.95		14.95	30
157	5785 MHz	15.03		15.03	
165	5825 MHz	15.14		15.14	
802.11n(HT20) Power					
Channel	Frequency	Conducted Power (dBm)			Max. Limit (dBm)
		Ant. 0	Ant. 1	Total	
149	5745 MHz	12.22	11.56	14.91	30
157	5785 MHz	12.34	11.64	15.01	
165	5825 MHz	12.48	11.69	15.11	
802.11ac(20) Power					
Channel	Frequency	Conducted Power (dBm)			Max. Limit (dBm)
		Ant. 0	Ant. 1	Total	
149	5745 MHz	12.32	11.70	15.03	30
157	5785 MHz	12.54	11.76	15.17	
165	5825 MHz	12.79	11.85	15.35	
802.11n(HT40) Power					
Channel	Frequency	Conducted Power (dBm)			Max. Limit (dBm)
		Ant. 0	Ant. 1	Total	
151	5755 MHz	10.48	10.32	13.58	30
159	5795 MHz	10.67	10.44	13.56	
802.11ac(40) Power					
Channel	Frequency	Conducted Power (dBm)			Max. Limit (dBm)
		Ant. 0	Ant. 1	Total	
151	5755 MHz	10.25	9.87	13.07	30
159	5795 MHz	10.32	9.96	13.15	
802.11ac(80) Power					
Channel	Frequency	Conducted Power (dBm)			Max. Limit (dBm)
		Ant. 0	Ant. 1	Total	
159	5795 MHz	10.02	9.70	12.87	30

Note: The Antenna Gain is -1.0 dBi.

6. OCCUPIED BANDWIDTH MEASUREMENT

6.1 LIMITS

FCC Part 15.407, subpart E/ RSS 247	
Frequency Range (MHz)	Requirement
5150~5250	26 dB Bandwidth
5725~5850	6 dB Bandwidth>500 KHz

6.2 TEST PROCEDURE

The EUT was directly connected to the power meter and antenna output port as show in the block diagram as bellow.

Spectrum Parameters	Setting
6 dB Bandwidth	
Attenuation	Auto
Span	>6 dB Bandwidth
RBW	100 kHz
VBW	≥3RBW
Detector	Peak
Trace	Max Hold
26 dB Bandwidth	
Sweep Time	Auto
Spectrum Parameters	Setting
Attenuation	Auto
Span	>26 dB Bandwidth
RBW	1% of the emission bandwidth
VBW	≥RBW
Detector	Peak
Trace	Max Hold

6.3 TEST SETUP

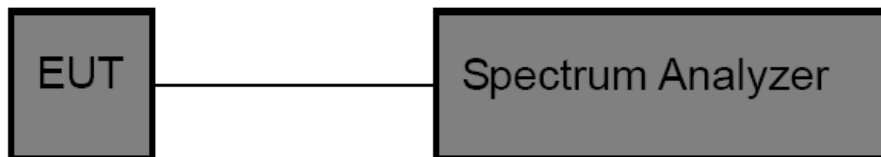

6.4 TEST INSTRUMENTS

Equipment	Manufacturer	Type No.	Serial No.	Last calibration	Calibrated until	Calibration period
Spectrum Analyzer	R&S	FSP40	100154	Jul. 04. 2016	Jul. 03. 2017	1 year

6.5 EUT OPERATING CONDITIONS

The EUT was set to continuously transmitting in the maximum power during the test.

6.6 TEST RESULTS

802.11a Mode			
Frequency (MHz)	26dB Bandwidth (MHz)	99% OBW (MHz)	Limit
5180	21.4900	17.00	N/A
5200	21.4884	17.00	
5240	21.4890	17.00	

802.11a Mode 5180 MHz

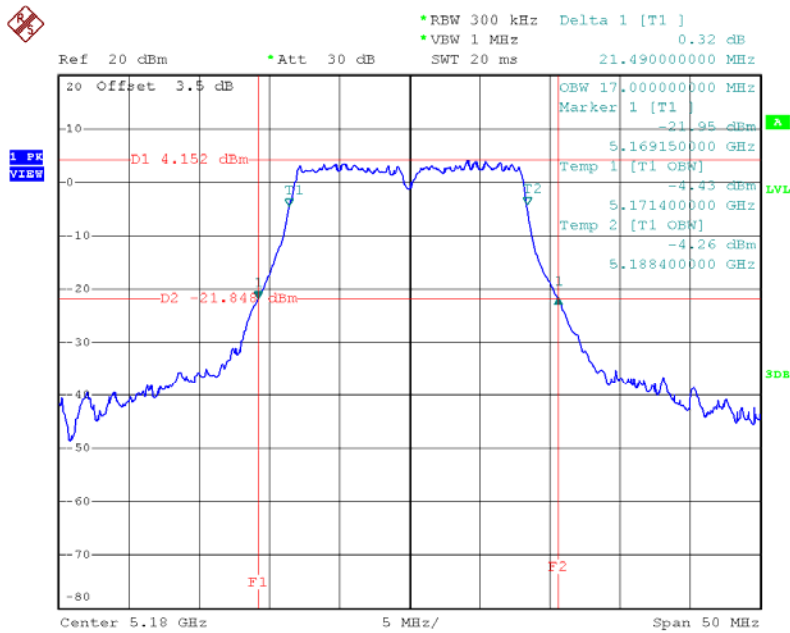

Date: 30.OCT.2016 12:22:32

802.11a Mode 5200 MHz

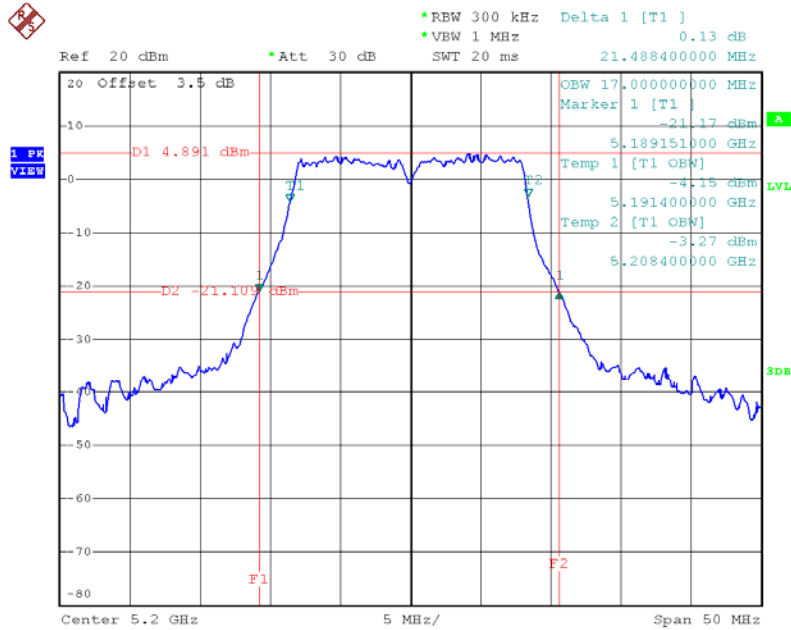

Date: 30.OCT.2016 12:23:34

802.11a Mode 5240 MHz

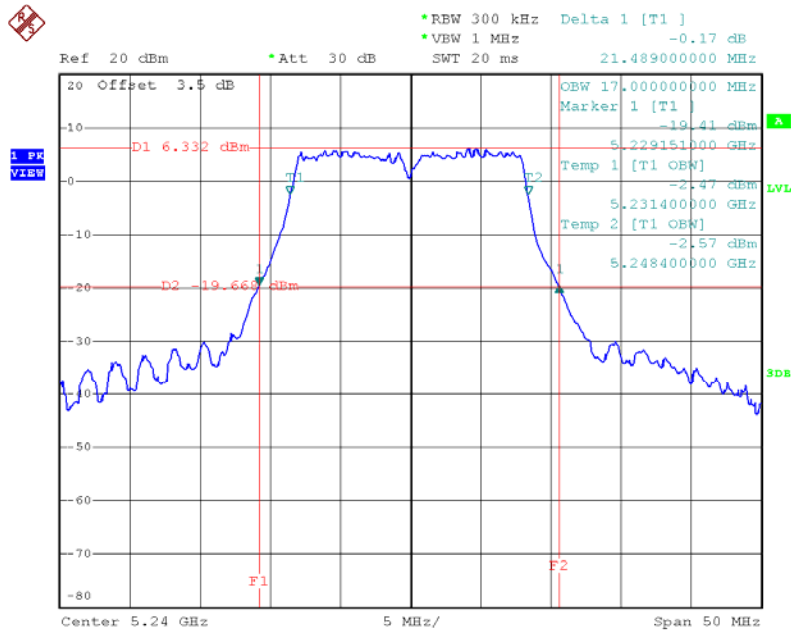

Date: 30.OCT.2016 12:24:41

802.11n(HT20) Mode			
Frequency (MHz)	26dB Bandwidth (MHz)	99% OBW (MHz)	Limit
5180	22.19995	17.90	N/A
5200	22.2900	17.90	
5240	22.2900	18.00	

802.11n(HT20) Mode 5180 MHz

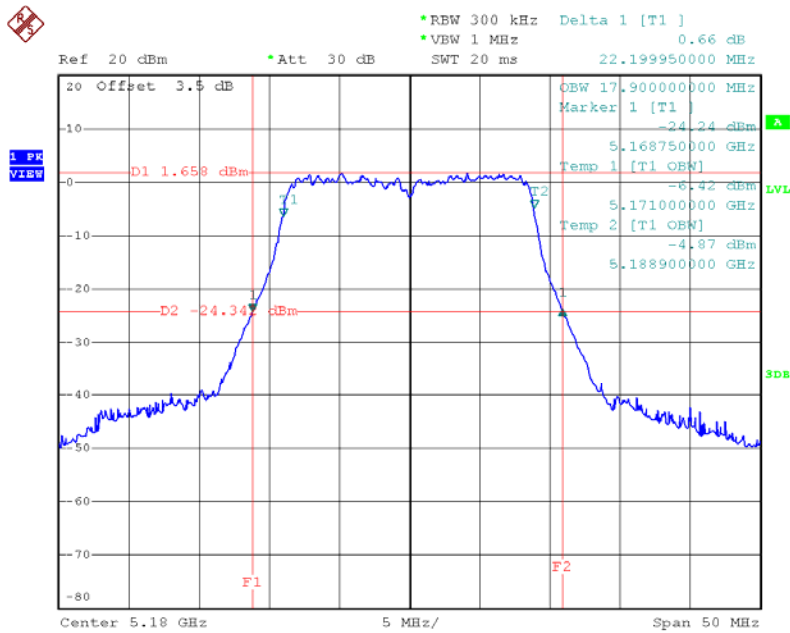

Date: 30.OCT.2016 12:29:19

802.11n(HT20) Mode 5200 MHz

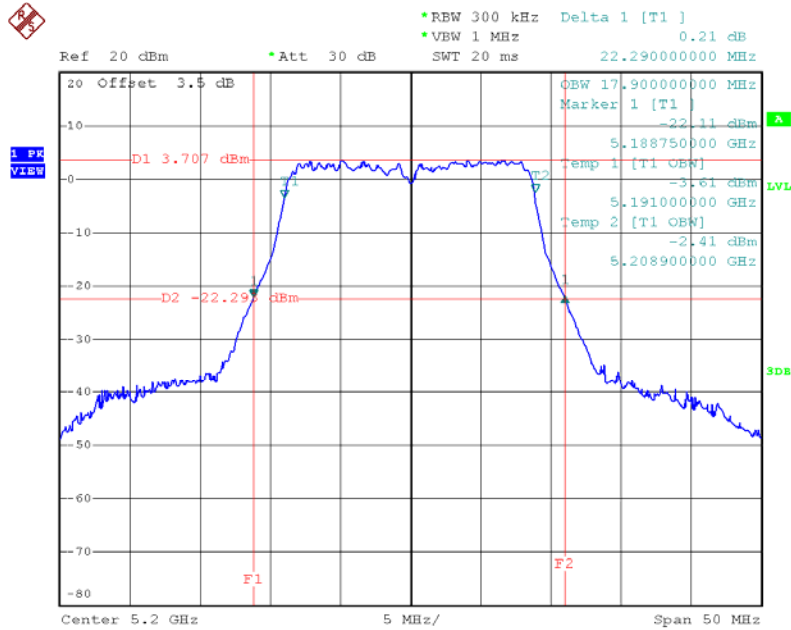

Date: 30.OCT.2016 14:26:20

802.11n(HT20) Mode 5240 MHz

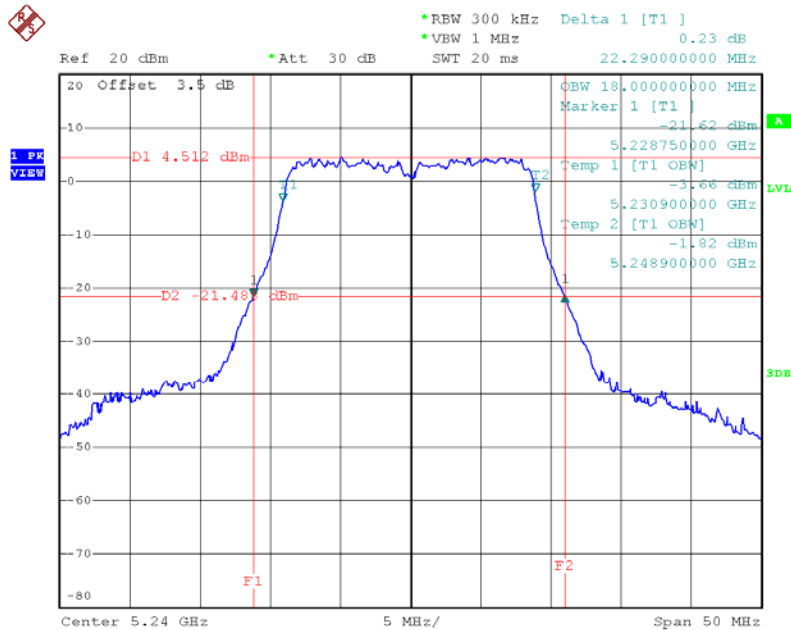

Date: 30.OCT.2016 14:28:31

802.11ac(20) Mode			
Frequency (MHz)	26dB Bandwidth (MHz)	99% OBW (MHz)	Limit
5180	22.19995	18.10	N/A
5200	22.2890	18.10	
5240	22.2890	18.00	

802.11ac(20) Mode 5180 MHz

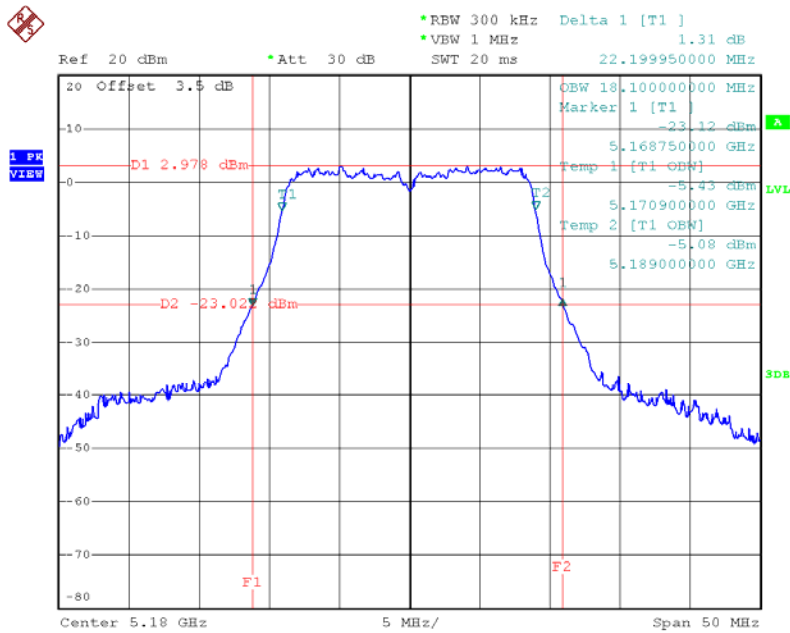

Date: 30.OCT.2016 14:47:21

802.11ac(20) Mode 5200 MHz

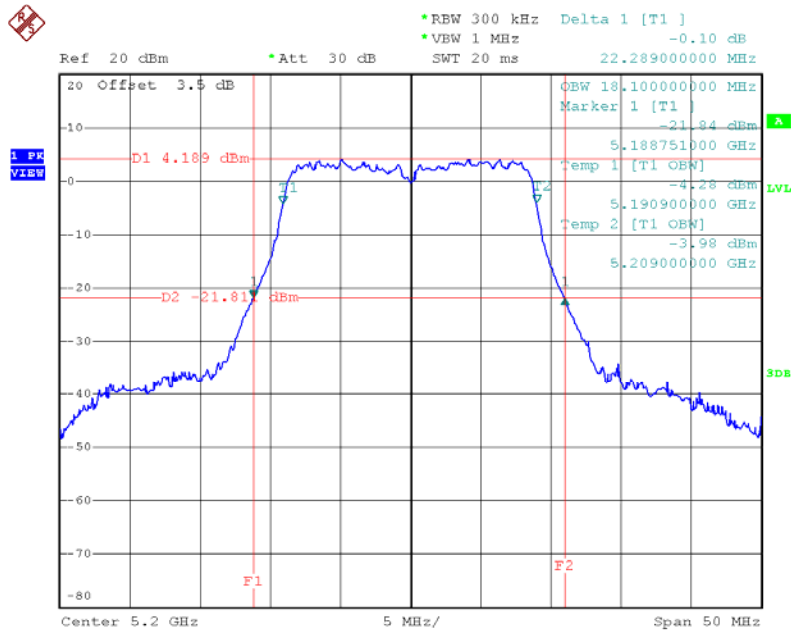

Date: 30.OCT.2016 14:48:23

802.11ac(20) Mode 5240 MHz

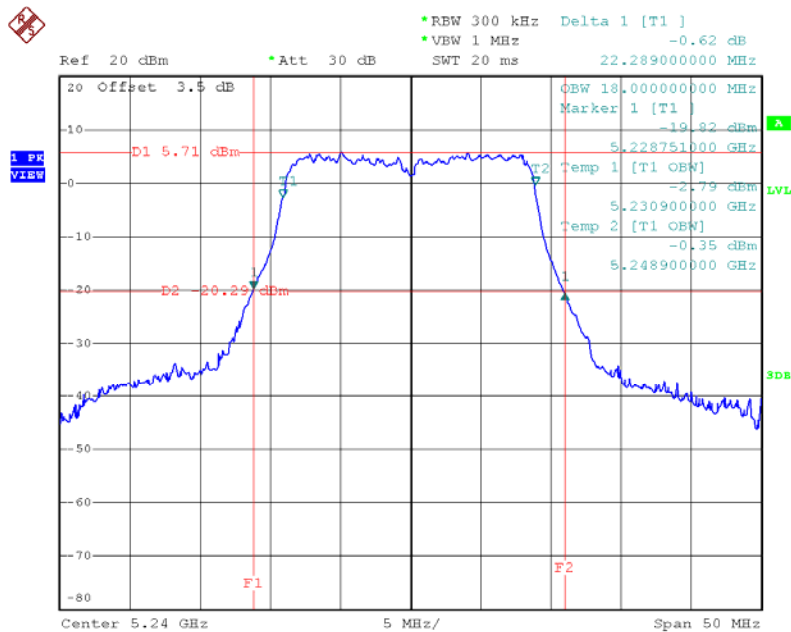

Date: 30.OCT.2016 14:49:26

802.11n(HT40) Mode			
Frequency (MHz)	26dB Bandwidth (MHz)	99% OBW (MHz)	Limit
5190	43.0091	36.40	N/A
5230	43.1000	36.40	

802.11n(HT40) Mode 5190 MHz

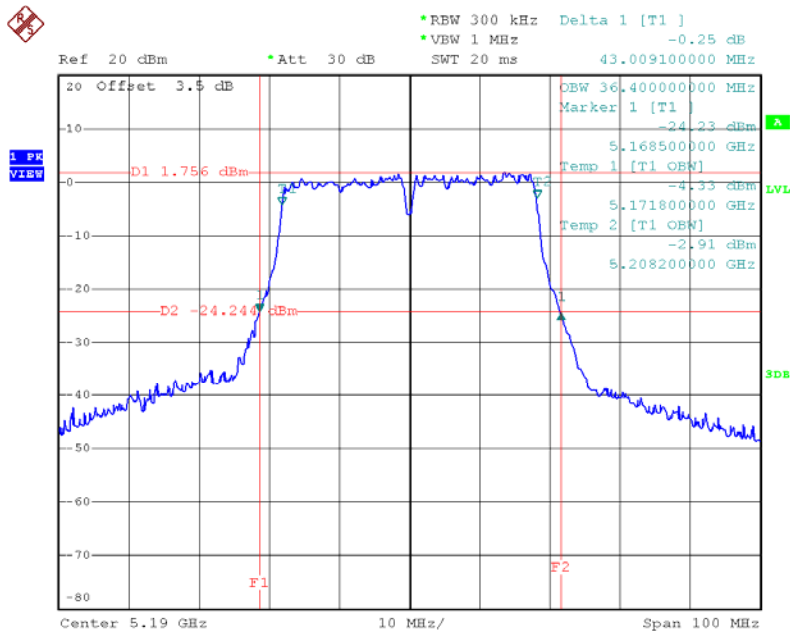

Date: 30.OCT.2016 14:59:36

802.11n(HT40) Mode 5230 MHz

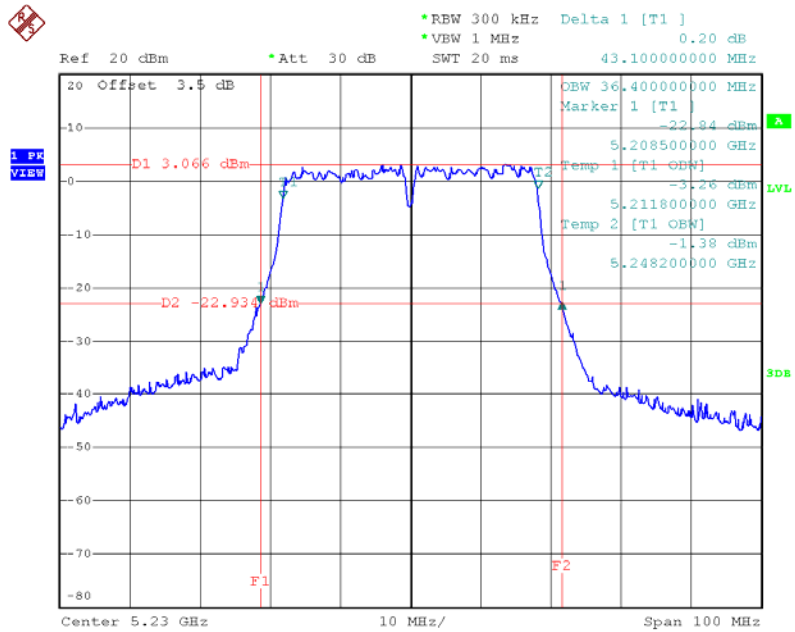

Date: 30.OCT.2016 15:00:48

802.11ac(40) Mode			
Frequency (MHz)	26dB Bandwidth (MHz)	99% OBW (MHz)	Limit
5190	43.0091	36.40	N/A
5230	43.1000	36.40	

802.11ac(40) Mode 5190 MHz

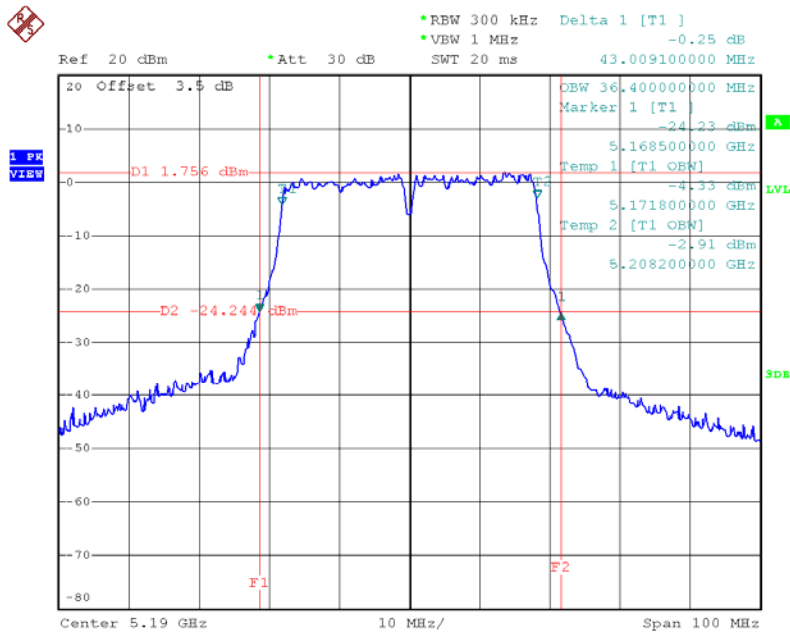

Date: 30.OCT.2016 14:59:36

802.11ac(40) Mode 5230 MHz

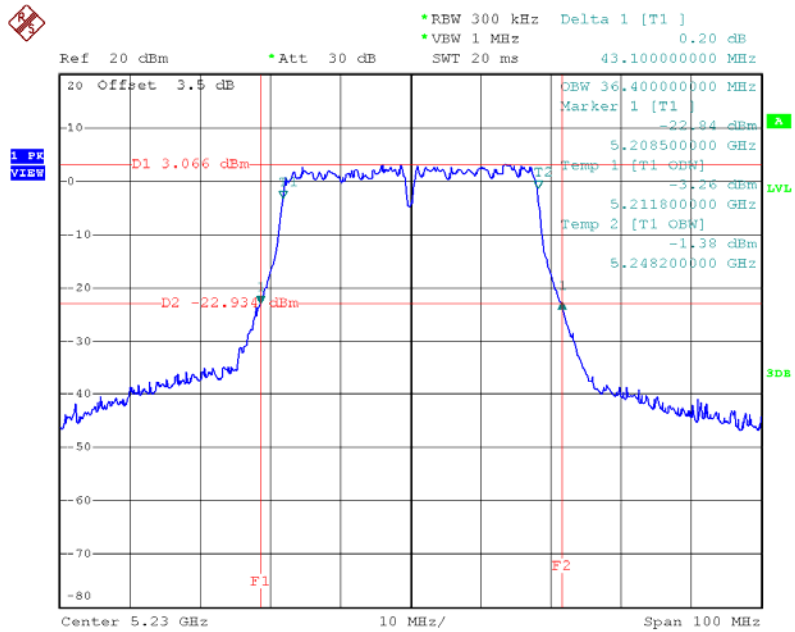

Date: 30.OCT.2016 15:00:48

802.11ac(80) Mode			
Frequency (MHz)	26dB Bandwidth (MHz)	99% OBW (MHz)	Limit
5210	82.599975	75.60	N/A

802.11ac(80) Mode 5210 MHz

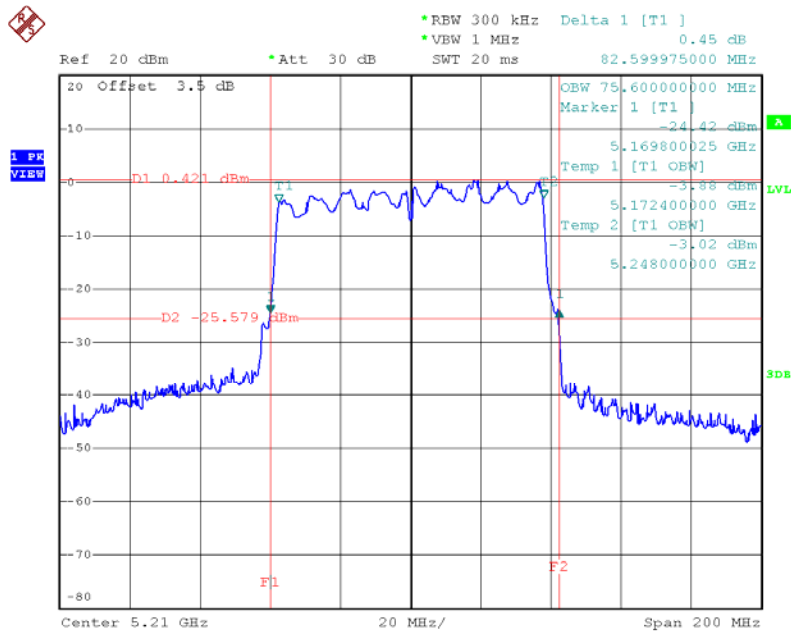

Date: 30.OCT.2016 15:37:02

802.11a Mode			
Frequency (MHz)	6dB Bandwidth (MHz)	99% OBW (MHz)	Limit
5745	16.549975	16.60	≥500 kHz
5785	16.799975	16.70	
5825	16.699950	16.70	

802.11a Mode 5745MHz

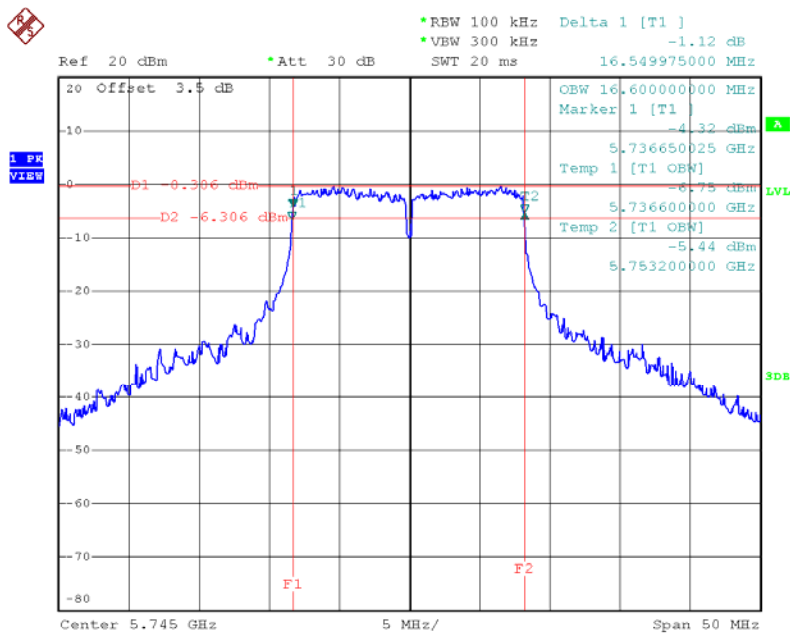

Date: 30.OCT.2016 12:26:05

802.11a Mode 5785MHz

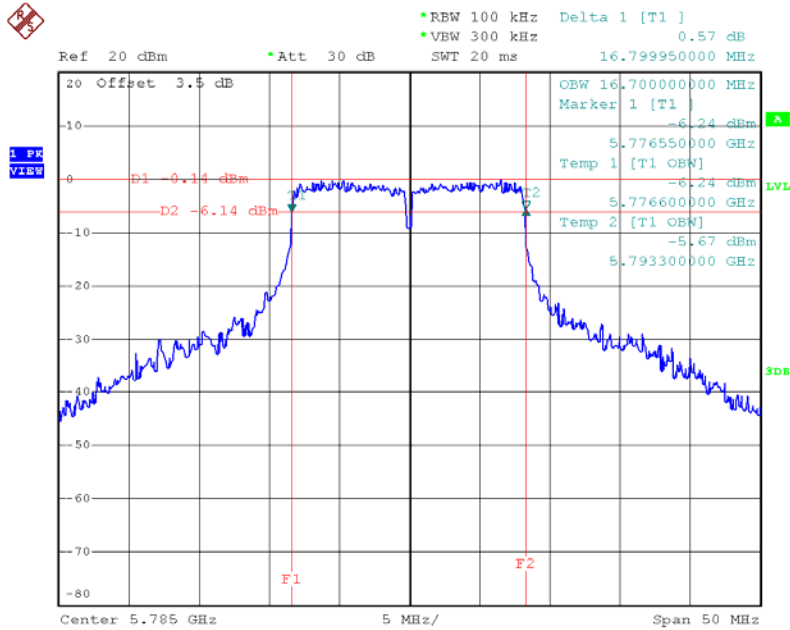

Date: 30.OCT.2016 12:27:00

802.11a Mode 5825MHz

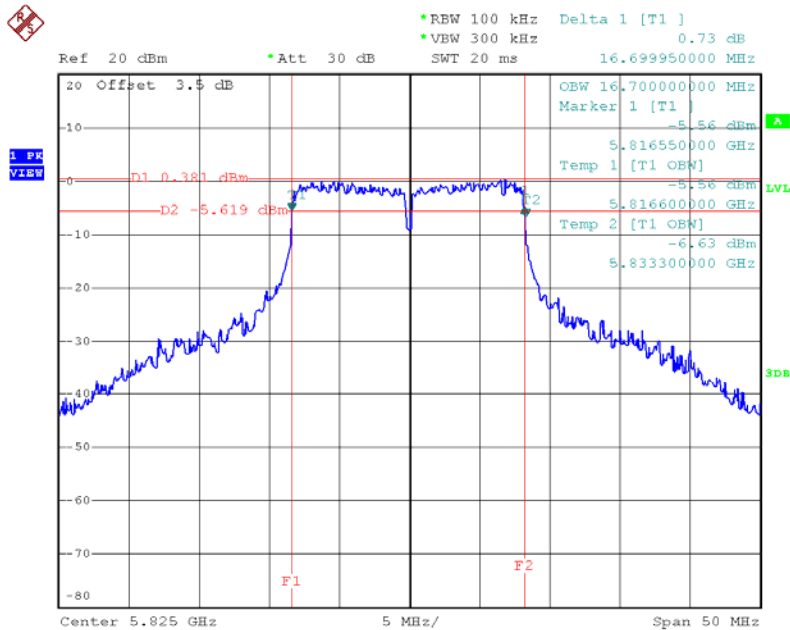

Date: 30.OCT.2016 12:27:54

802.11n(HT20) Mode			
Frequency (MHz)	6dB Bandwidth (MHz)	99% OBW (MHz)	Limit
5745	17.849992	17.80	≥500 kHz
5785	17.899950	17.90	
5825	17.849975	18.00	

802.11n(HT20) Mode 5745MHz

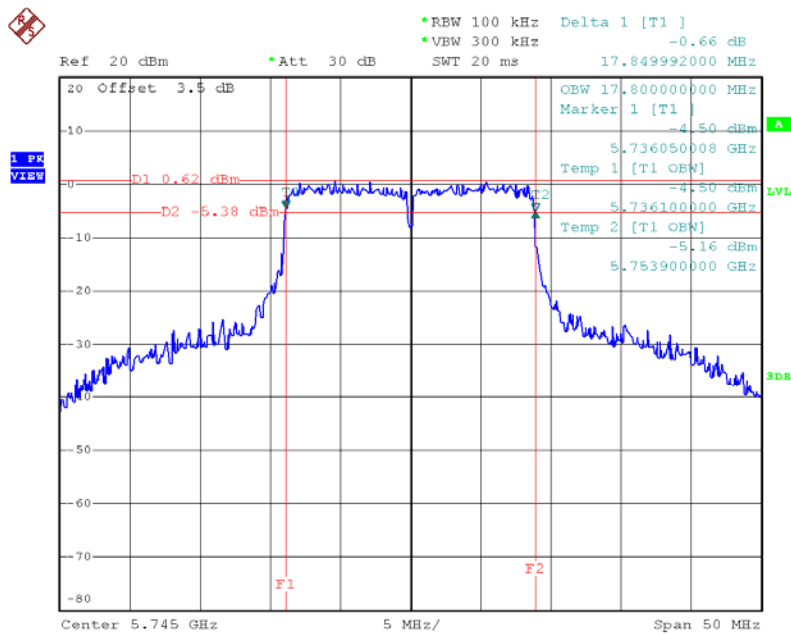

Date: 30.OCT.2016 14:29:37

802.11n(HT20) Mode 5785MHz

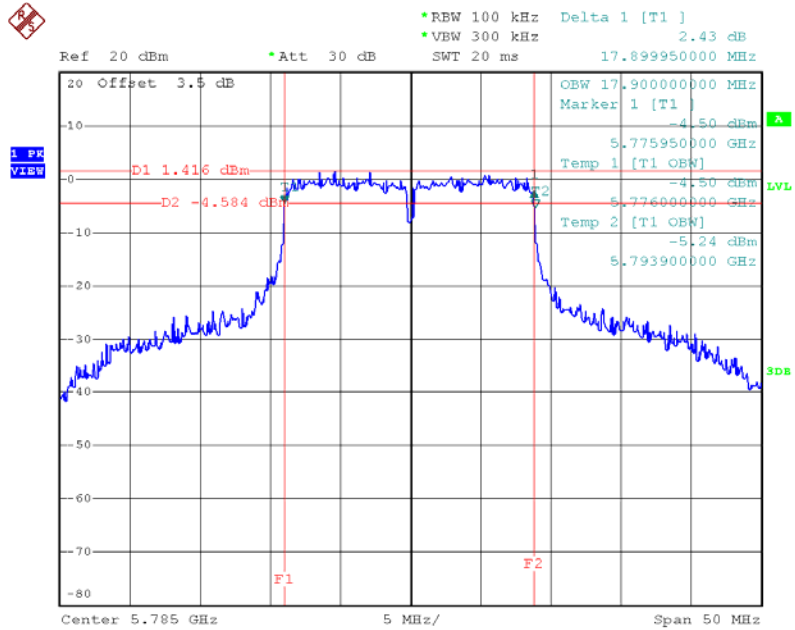

Date: 30.OCT.2016 14:35:05

802.11n(HT20) Mode 5825MHz

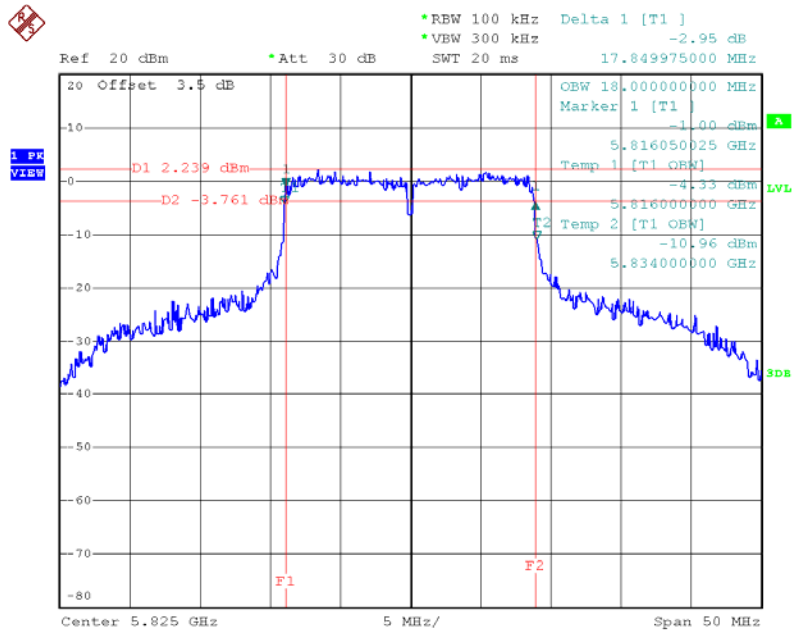

Date: 30.OCT.2016 14:36:16

802.11ac(20) Mode			
Frequency (MHz)	6dB Bandwidth (MHz)	99% OBW (MHz)	Limit
5745	17.799925	19.40	>=500 kHz
5785	17.799925	18.60	
5825	17.789392	19.40	

802.11ac(20) Mode 5745MHz

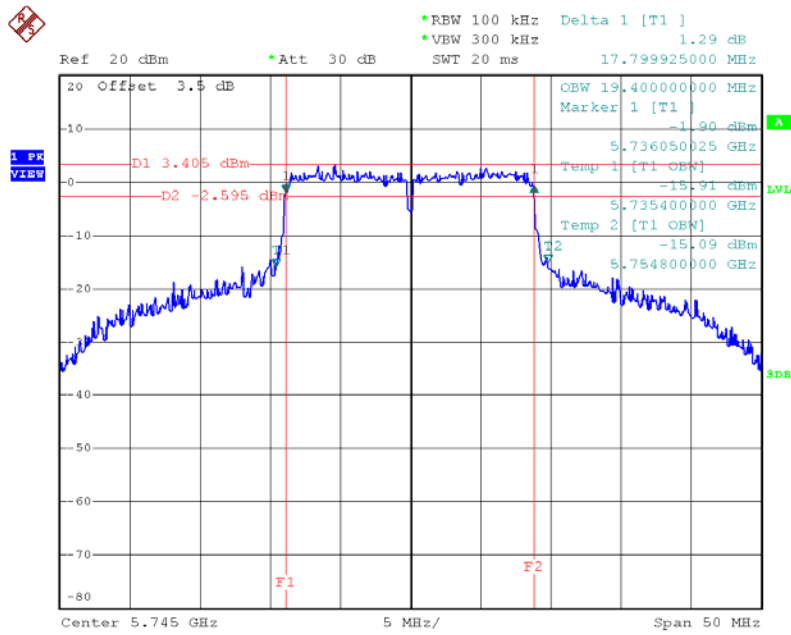

Date: 30.OCT.2016 14:50:27

802.11ac(20) Mode 5785MHz

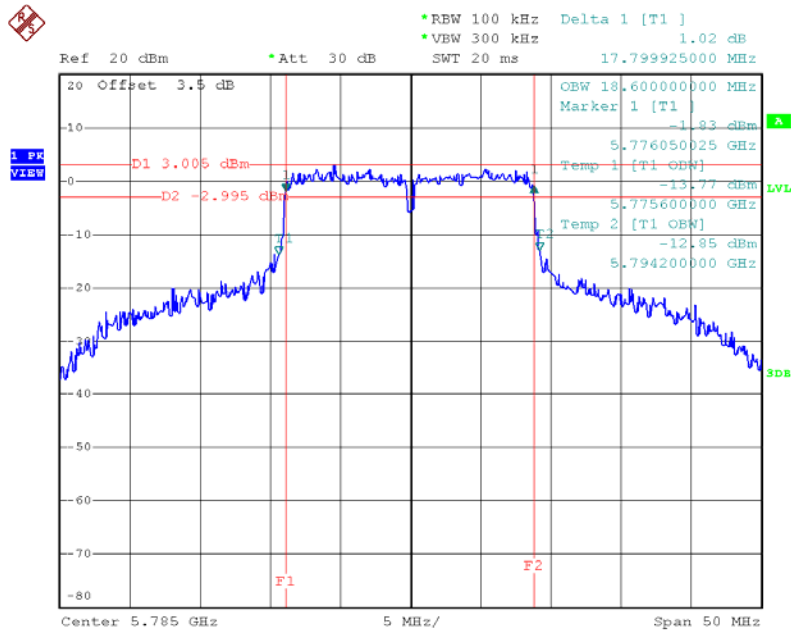

Date: 30.OCT.2016 14:54:38

802.11ac(20) Mode 5825MHz

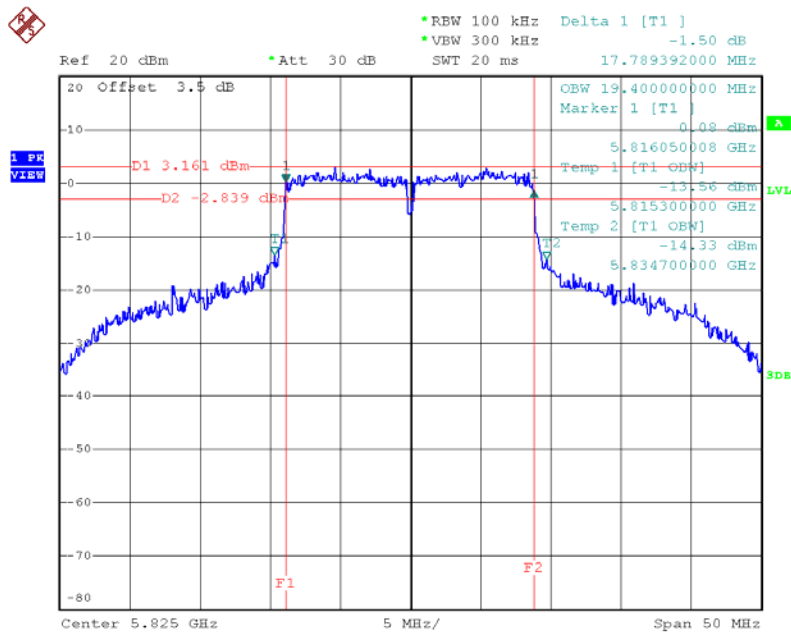

Date: 30.OCT.2016 14:55:37

802.11n(HT40) Mode			
Frequency (MHz)	6dB Bandwidth (MHz)	99% OBW (MHz)	Limit
5755	36.90000	39.60	>=500 kHz
5795	36.799937	50.40	

802.11n(HT40) Mode 5755MHz

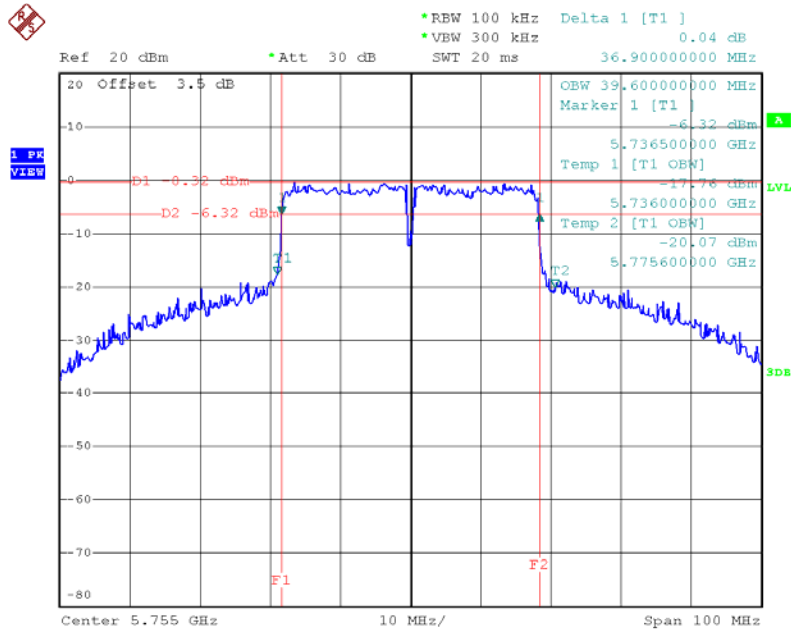

Date: 30.OCT.2016 15:02:00

802.11n(HT40) Mode 5795MHz

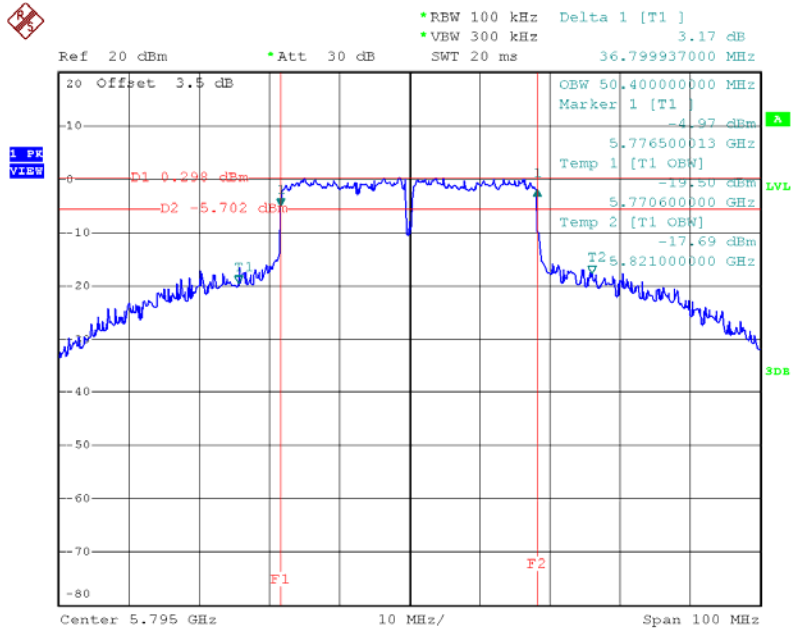

Date: 30.OCT.2016 15:06:26

802.11ac(40) Mode			
Frequency (MHz)	6dB Bandwidth (MHz)	99% OBW (MHz)	Limit
5755	36.80910	38.80	≥500 kHz
5795	36.799937	38.20	

802.11ac(40) Mode 5755MHz

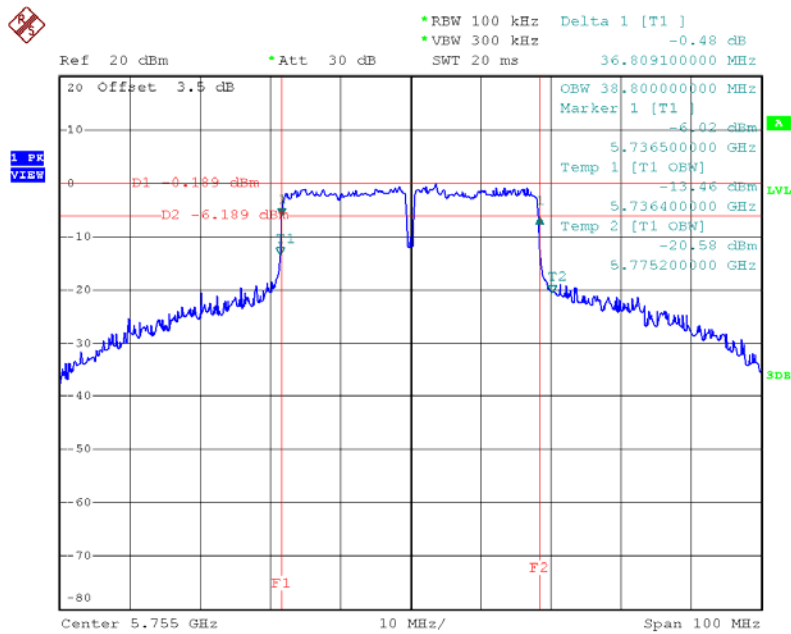

Date: 30.OCT.2016 15:13:05

802.11ac(40) Mode 5795MHz

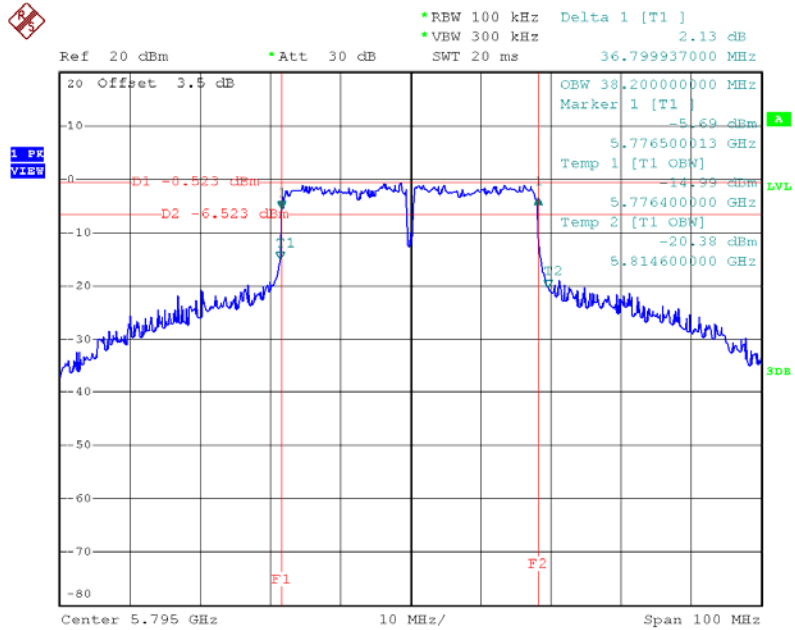

Date: 30.OCT.2016 15:15:37

802.11ac(80) Mode			
Frequency (MHz)	6dB Bandwidth (MHz)	99% OBW (MHz)	Limit
5775	77.199937	85.20	>=500 kHz

802.11ac(80) Mode 5775MHz

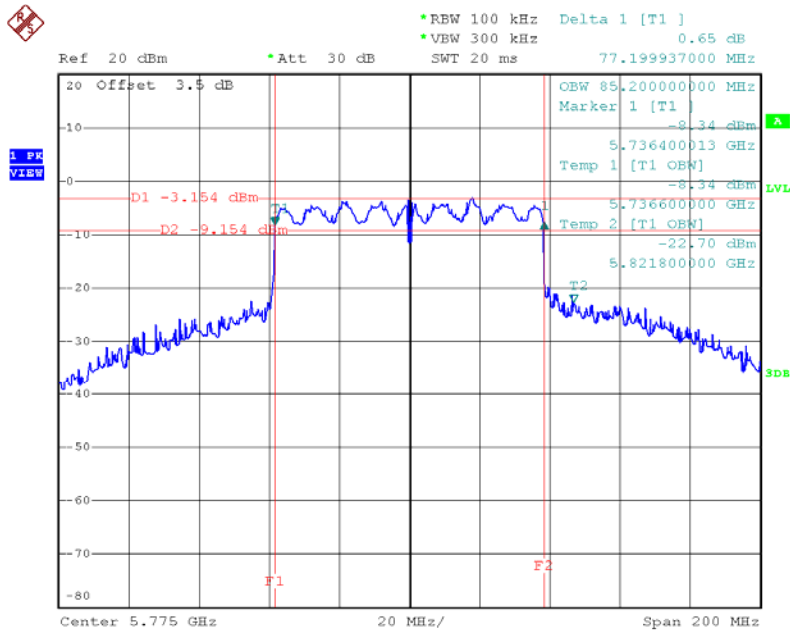

Date: 30.OCT.2016 15:41:31

7. POWER SPECTRAL DENSITY

7.1 LIMITS

FCC Part 15.407, Subpart E/ RSS 247	
Frequency Range (MHz)	Limits
5150~5250	Mobile and Portable: 11 dBm/MHz Other: 17 dBm/MHz
5725~5850	30 dBm/500kHz

7.2 TEST PROCEDURE

The EUT was directly connected to the power meter and antenna output port as show in the block diagram as bellow.

Spectrum Parameters	Setting
Attenuation	Auto
Span	Set the span to encompass the EBW
RBW	1 MHz
VBW	3 MHz
Detector	RMS
Trace	Max Hold
Sweep Time	Auto
Trace	100 Traces in power averaging

7.3 TEST SETUP

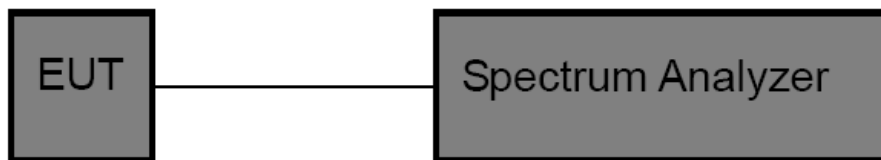

7.4 TEST INSTRUMENTS

Equipment	Manufacturer	Type No.	Serial No.	Last calibration	Calibrated until	Calibration period
Spectrum Analyzer	R&S	FSP40	100154	Jul. 04. 2016	Jul. 03. 2017	1 year

7.5 EUT OPERATING CONDITIONS

The EUT was set to continuously transmitting in the maximum power during the test.

7.6 TEST RESULTS

802.11a Mode					
Frequency (MHz)	Power Density (dBm/MHz)			Limit (dBm/MHz)	Result
	ANT 0	ANT 1	Total		
5180	1.55		1.55	11	Pass
5200	2.44		2.44		
5240	3.61		3.61		

802.11a Mode 5180 MHz

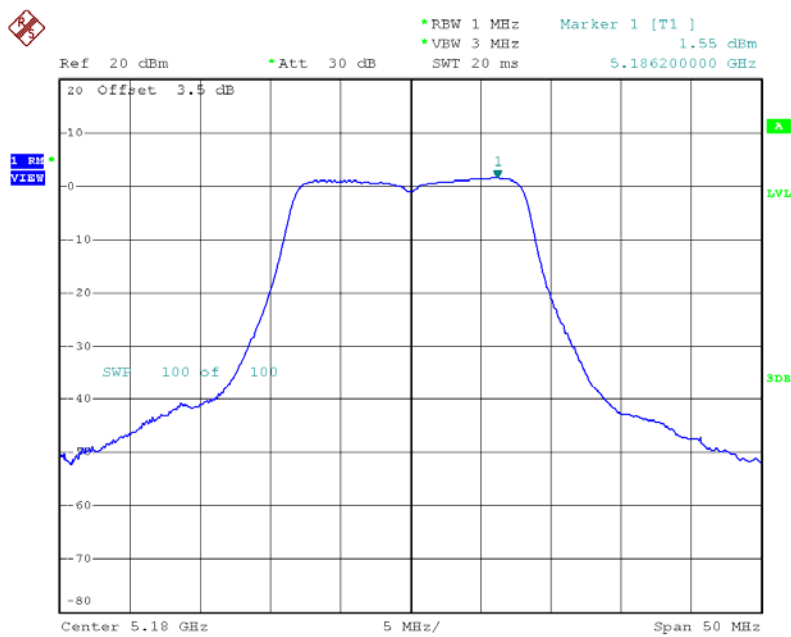

Date: 30.OCT.2016 12:22:41

802.11a Mode 5200 MHz

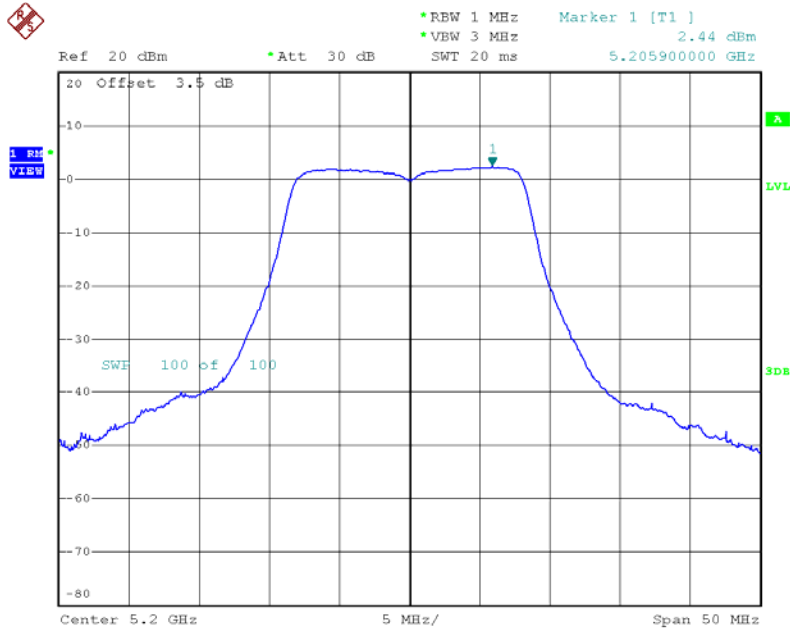

Date: 30.OCT.2016 12:23:44

802.11a Mode 5240 MHz

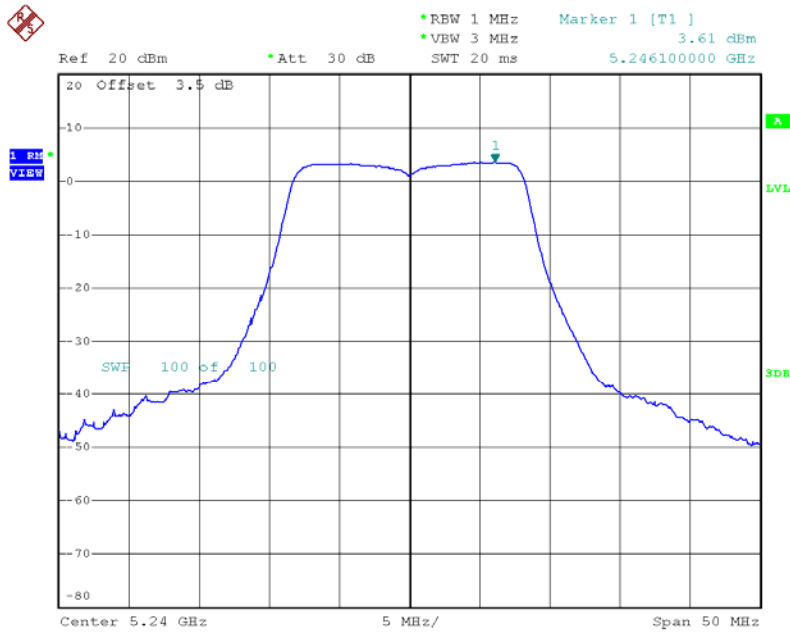

Date: 30.OCT.2016 12:24:51

802.11n(HT20) Mode					
Frequency (MHz)	Power Density (dBm/MHz)			Limit (dBm/MHz)	Result
	ANT 0	ANT 1	Total		
5180	-0.87	-1.09	2.03	11	Pass
5200	1.23	0.92	4.08		
5240	2.06	0.93	4.54		

802.11n(HT20) Mode 5180 MHz-ANT 0

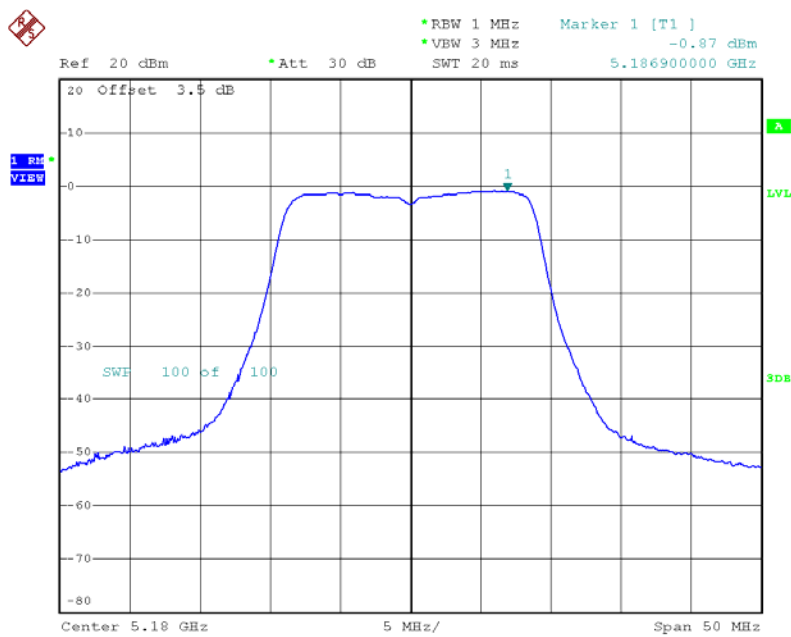

Date: 30.OCT.2016 12:29:28

802.11n(HT20) Mode 5200 MHz-ANT 0

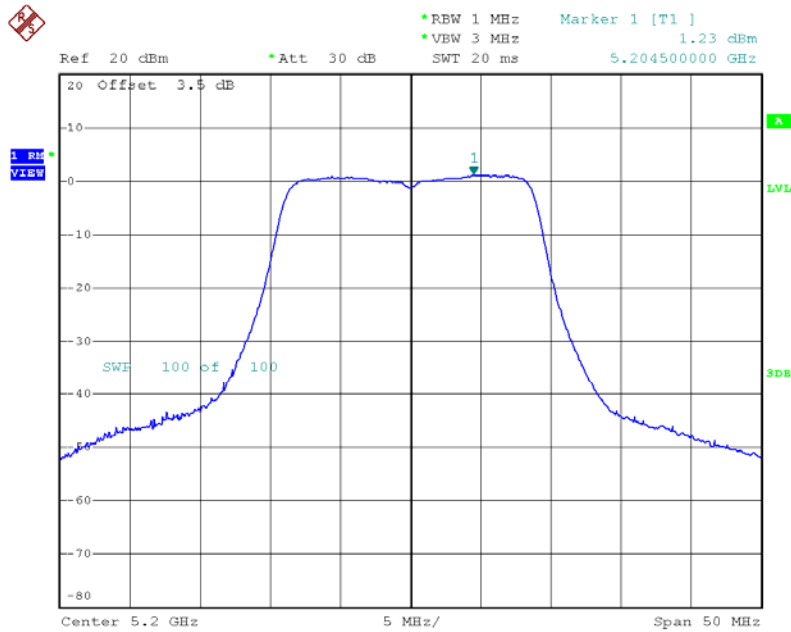

Date: 30.OCT.2016 14:26:30

802.11n(HT20) Mode 5240 MHz-ANT 0

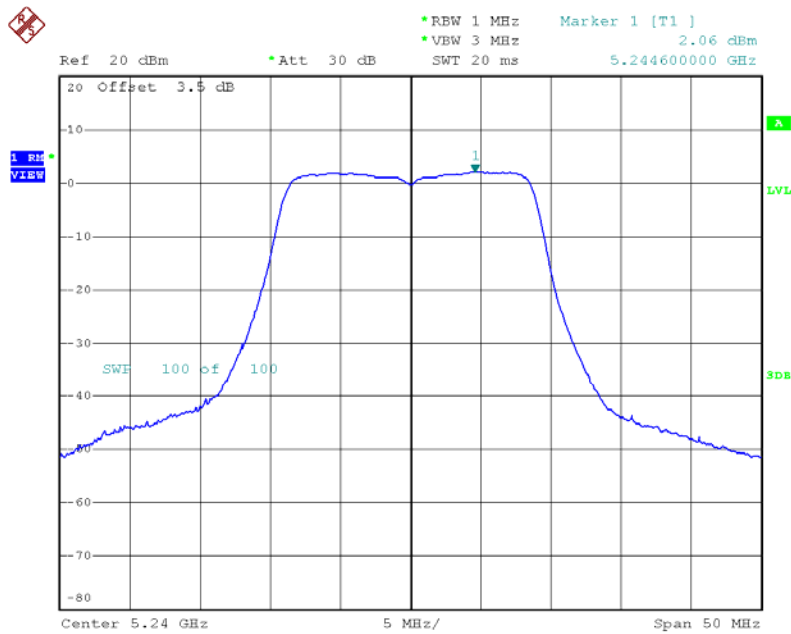

Date: 30.OCT.2016 14:28:41

802.11n(HT20) Mode 5180 MHz-ANT 1

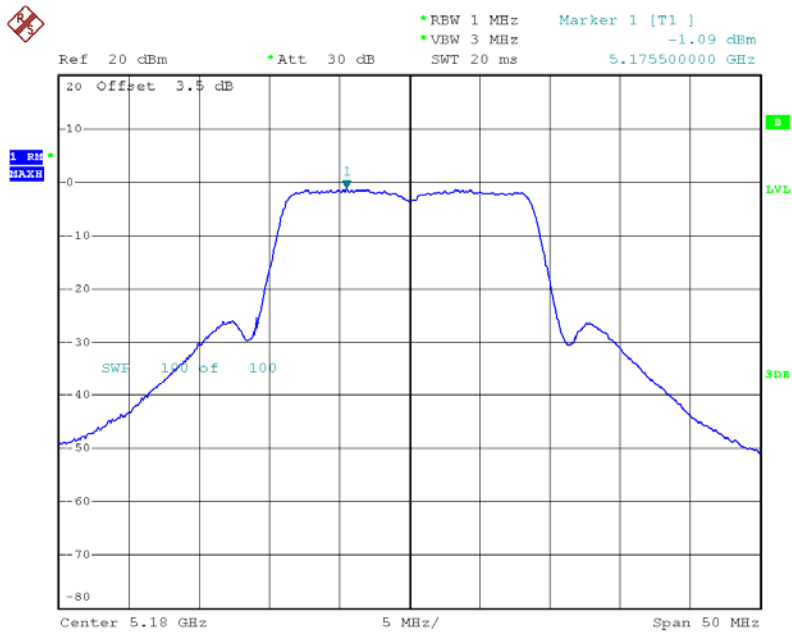

Date: 30.OCT.2016 11:50:59

802.11n(HT20) Mode 5200 MHz-ANT 1

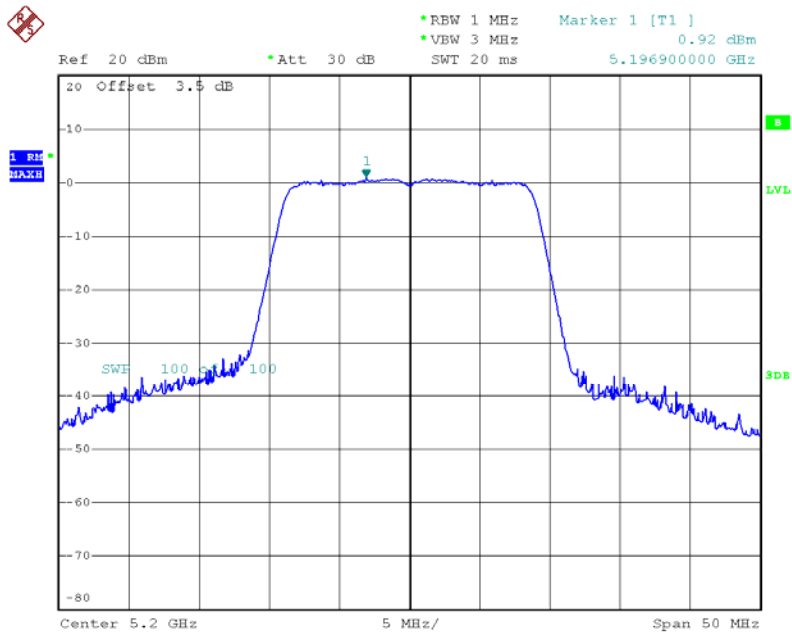

Date: 30.OCT.2016 13:20:09

802.11n(HT20) Mode 5240 MHz-ANT 1

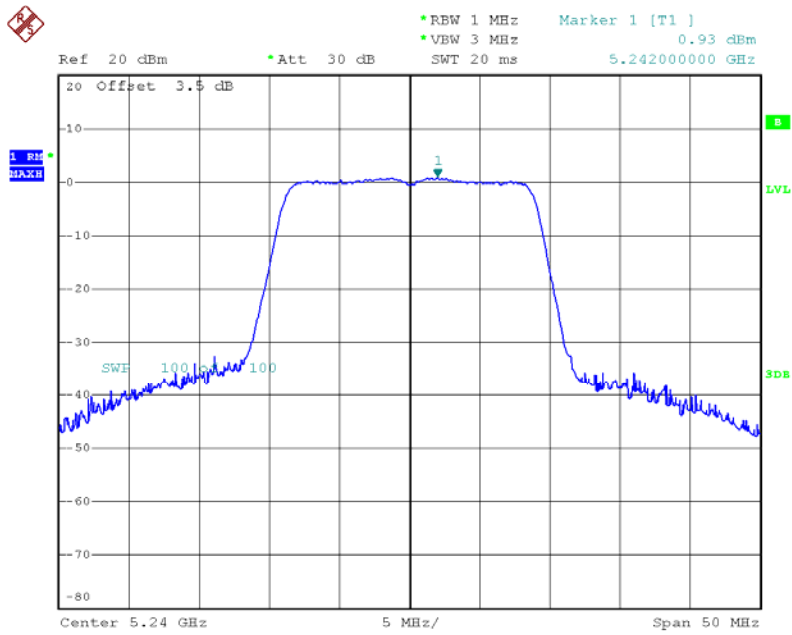

Date: 30.OCT.2016 13:16:41

802.11ac(20) Mode					
Frequency (MHz)	Power Density (dBm/MHz)			Limit (dBm/MHz)	Result
	ANT 0	ANT 1	Total		
5180	0.83	0.33	3.59	11	Pass
5200	1.94	0.94	4.47		
5240	3.18	0.98	5.22		

802.11ac(20) Mode 5180 MHz-ANT 0

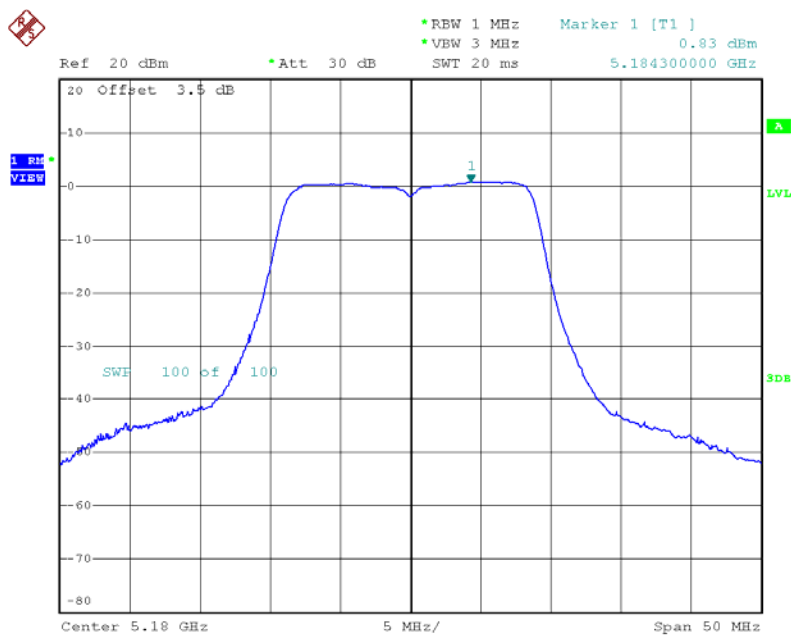

Date: 30.OCT.2016 14:47:31

802.11ac(20) Mode 5200 MHz-ANT 0

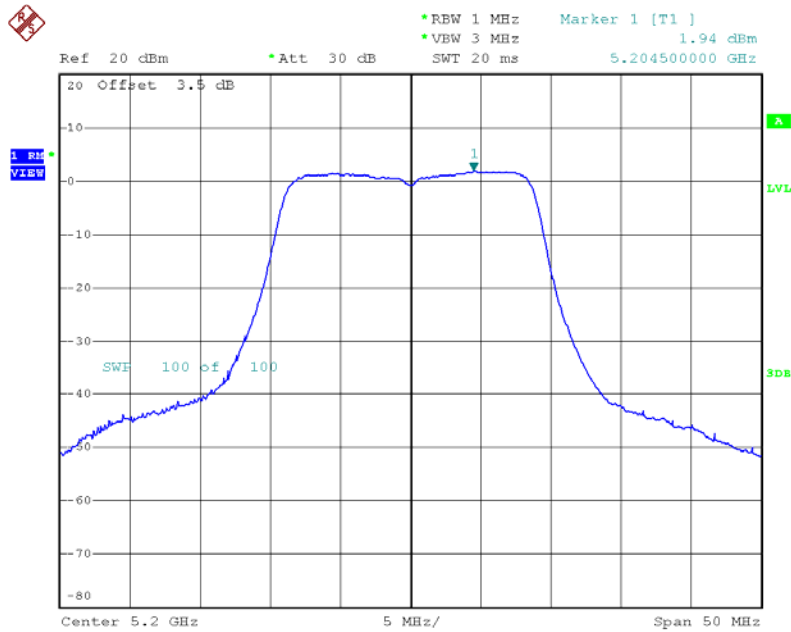

Date: 30.OCT.2016 14:48:33

802.11ac(20) Mode 5240 MHz-ANT 0

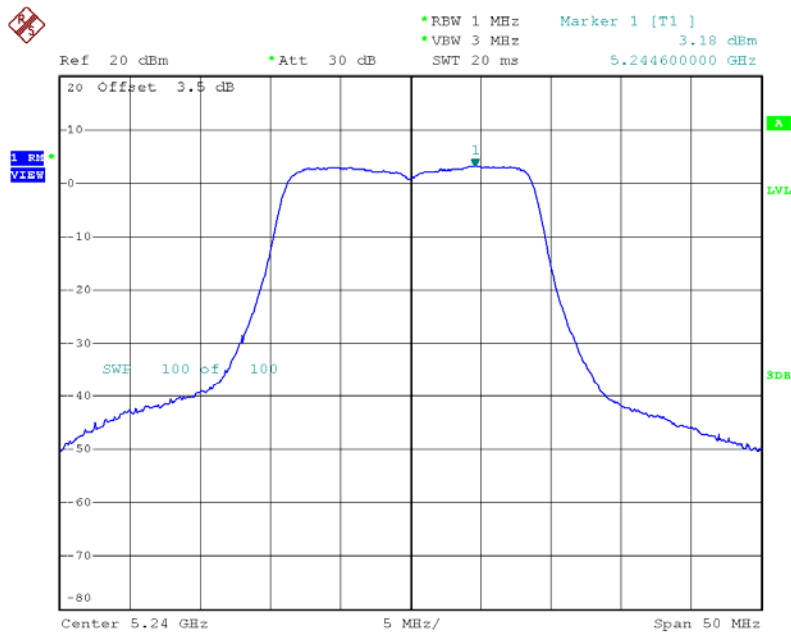

Date: 30.OCT.2016 14:49:35

802.11ac(20) Mode 5180 MHz-ANT 1

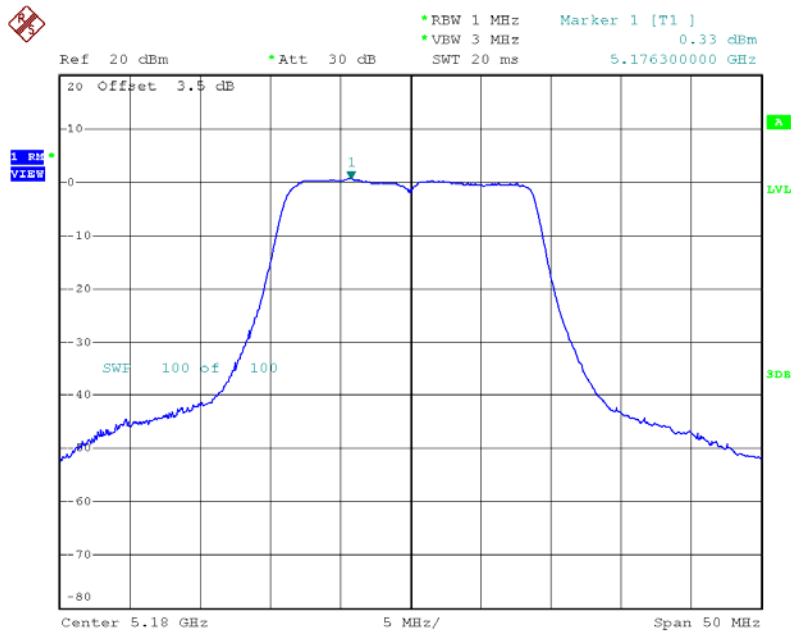

Date: 30.OCT.2016 13:07:31

802.11ac(20) Mode 5200 MHz-ANT 1

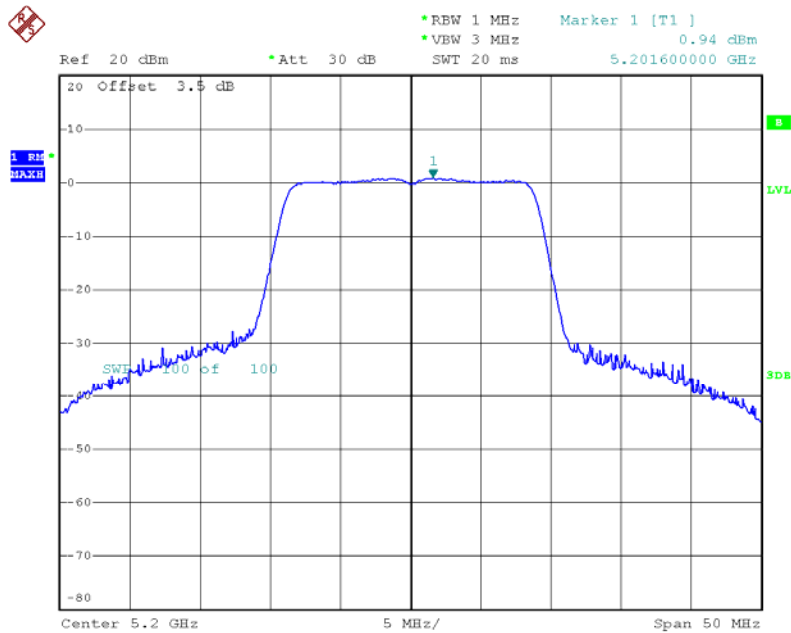

Date: 30.OCT.2016 13:03:17

802.11ac(20) Mode 5240 MHz-ANT 1

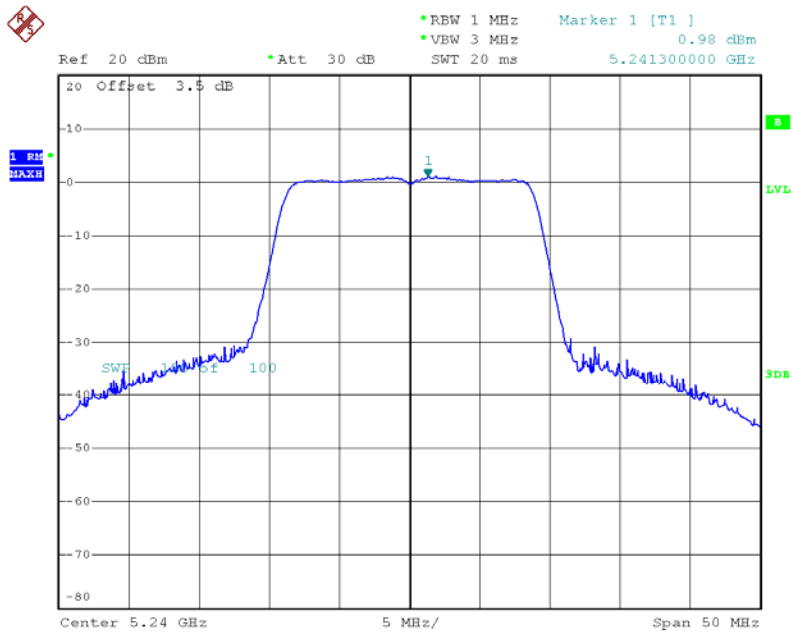

Date: 30.OCT.2016 12:51:59

801.11n(HT40) Mode					
Frequency (MHz)	Power Density (dBm/MHz)			Limit (dBm/MHz)	Result
	ANT 0	ANT 1	Total		
5190	-0.97	-1.95	1.57	11	Pass
5230	0.34	-0.48	2.95		

802.11n (HT40) Mode 5190 MHz-ANT 0

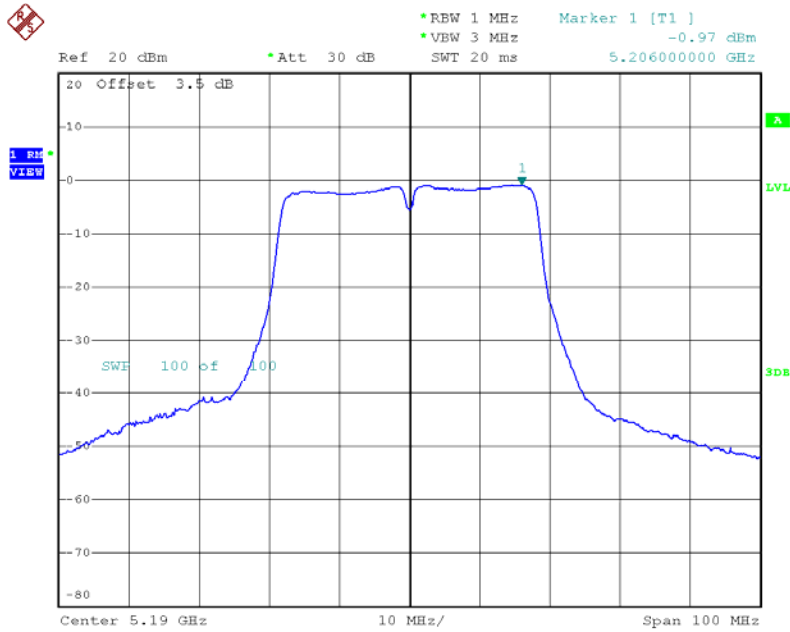

Date: 30.OCT.2016 14:59:45

802.11n (HT40) Mode 5230 MHz-ANT 0

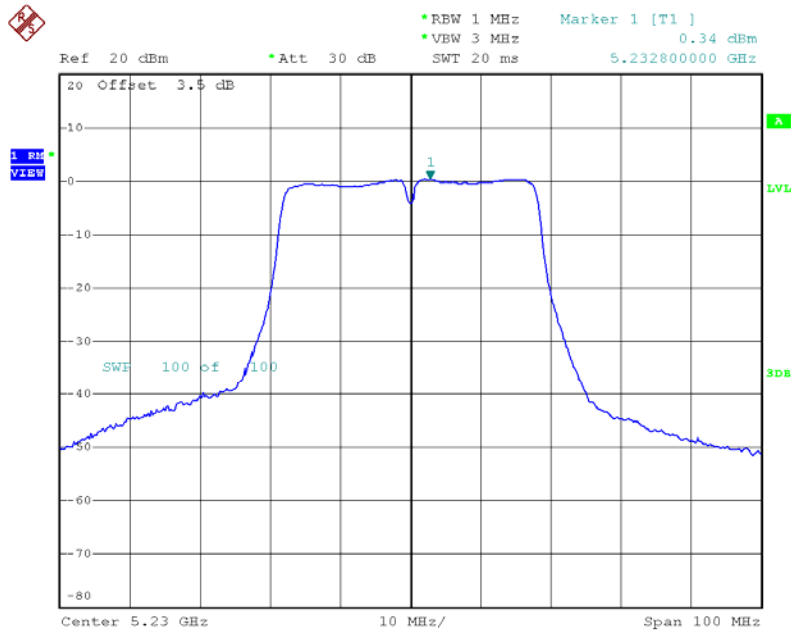

Date: 30.OCT.2016 15:00:58

802.11n (HT40) Mode 5190 MHz-ANT 1

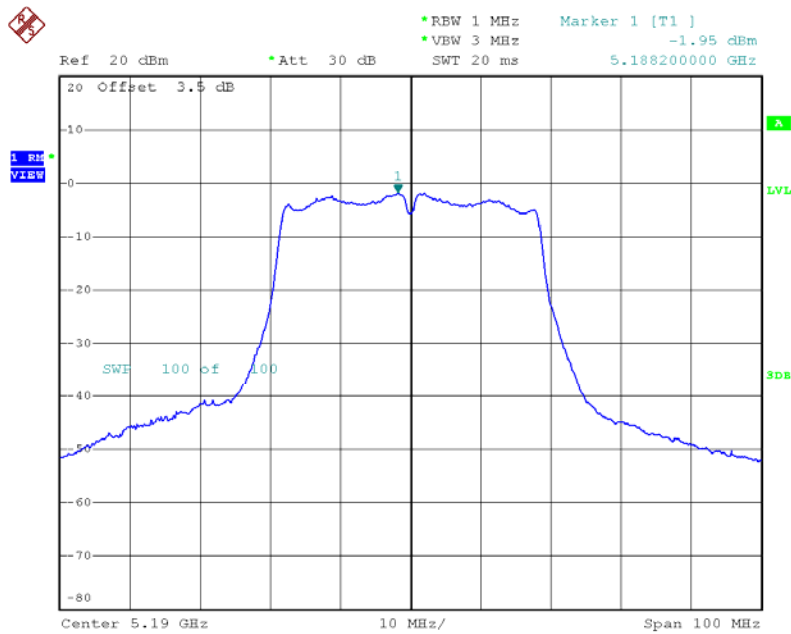

Date: 30.OCT.2016 14:29:45

802.11n (HT40) Mode 5230 MHz-ANT 1

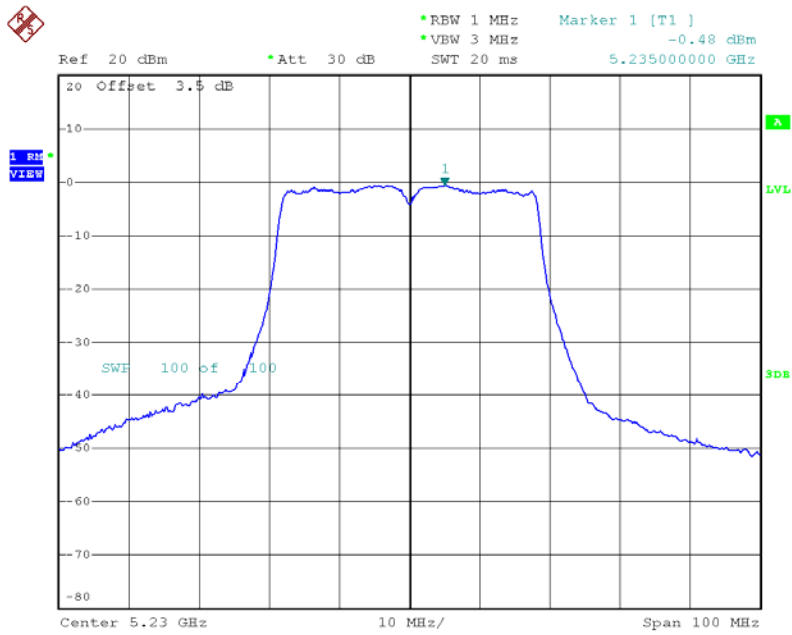

Date: 30.OCT.2016 14:22:58

801.11ac(40) Mode					
Frequency (MHz)	Power Density (dBm/MHz)			Limit (dBm/MHz)	Result
	ANT 0	ANT 1	Total		
5190	-1.69	-2.80	0.80	11	Pass
5230	0.08	-0.64	2.74		

802.11ac (40) Mode 5190 MHz-ANT 0

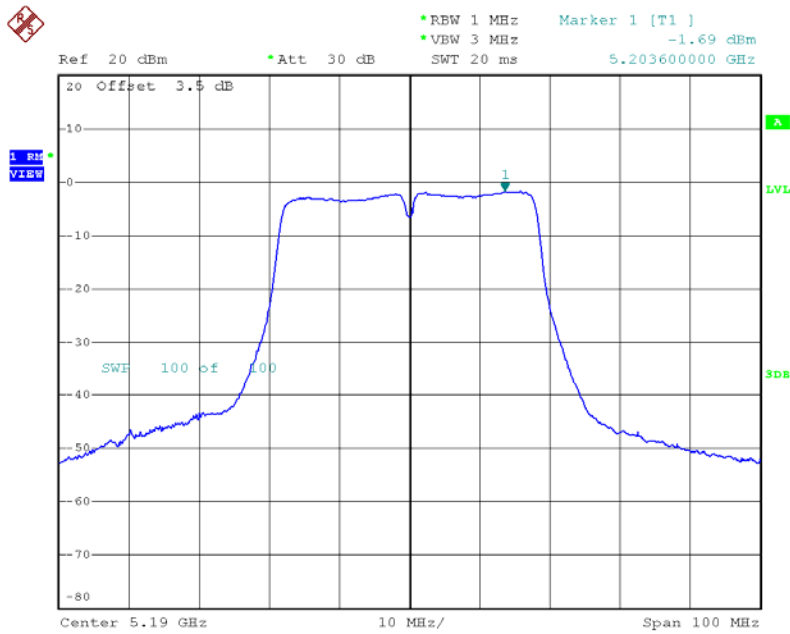

Date: 30.OCT.2016 15:10:54

802.11ac (40) Mode 5230 MHz-ANT 0

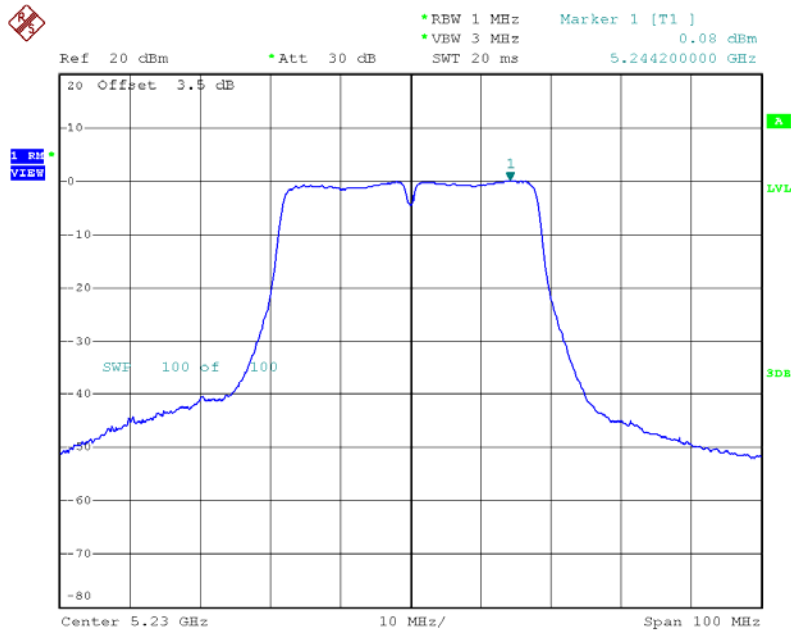

Date: 30.OCT.2016 15:12:03

802.11ac (40) Mode 5190 MHz-ANT 1

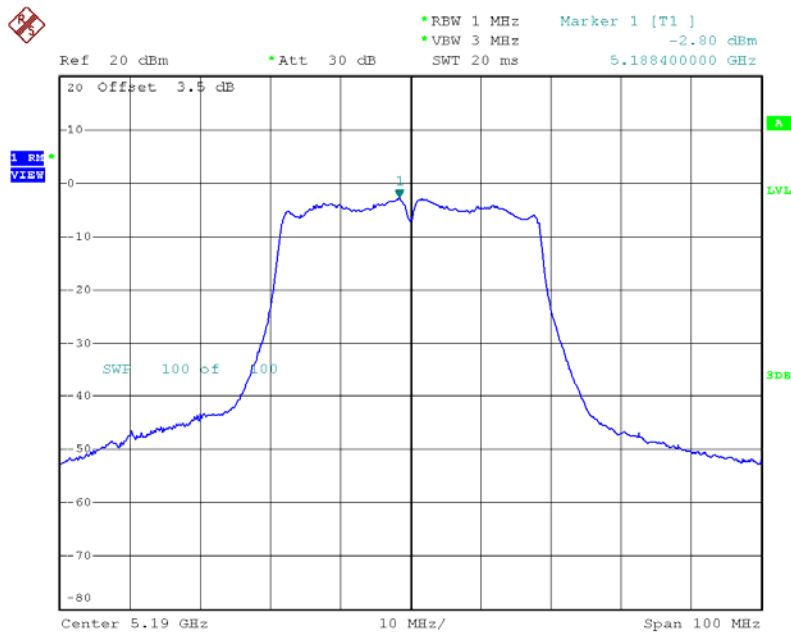

Date: 30.OCT.2016 12:00:54

802.11ac (40) Mode 5230 MHz-ANT 1

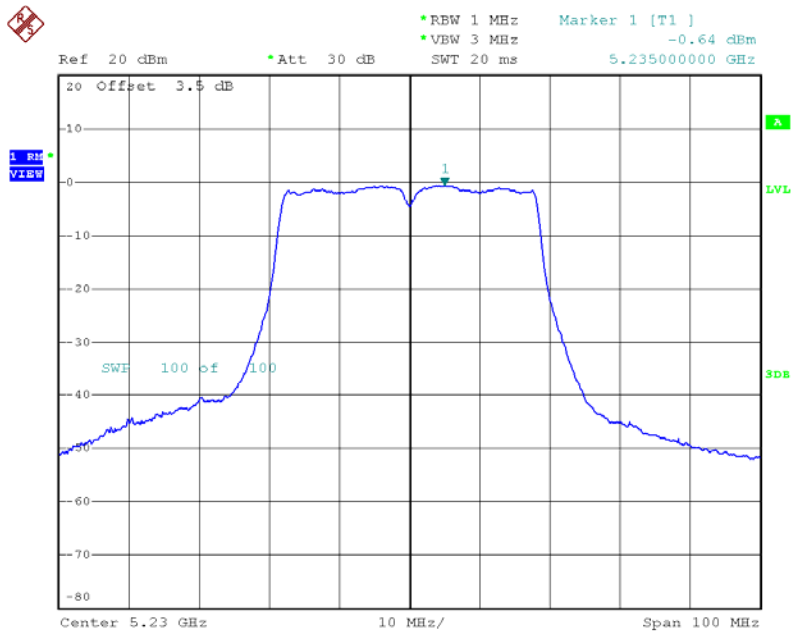

Date: 30.OCT.2016 13:12:03

801.11ac(80) Mode					
Frequency (MHz)	Power Density (dBm/MHz)			Limit (dBm/MHz)	Result
	ANT 0	ANT 1	Total		
5210	-2.21	-2.53	0.64	11	Pass

802.11ac (80) Mode 5210 MHz-ANT 0

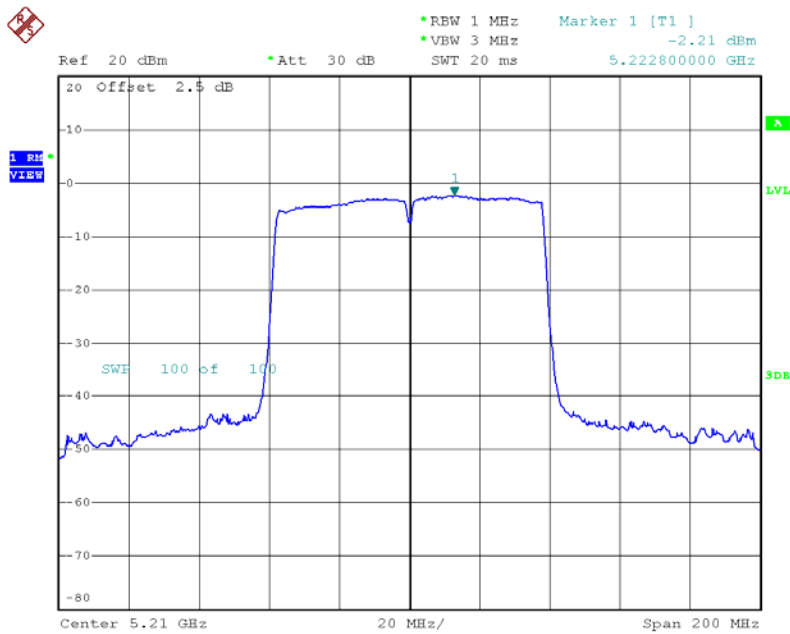

Date: 30.OCT.2016 15:44:11

802.11ac (80) Mode 5210 MHz-ANT 1

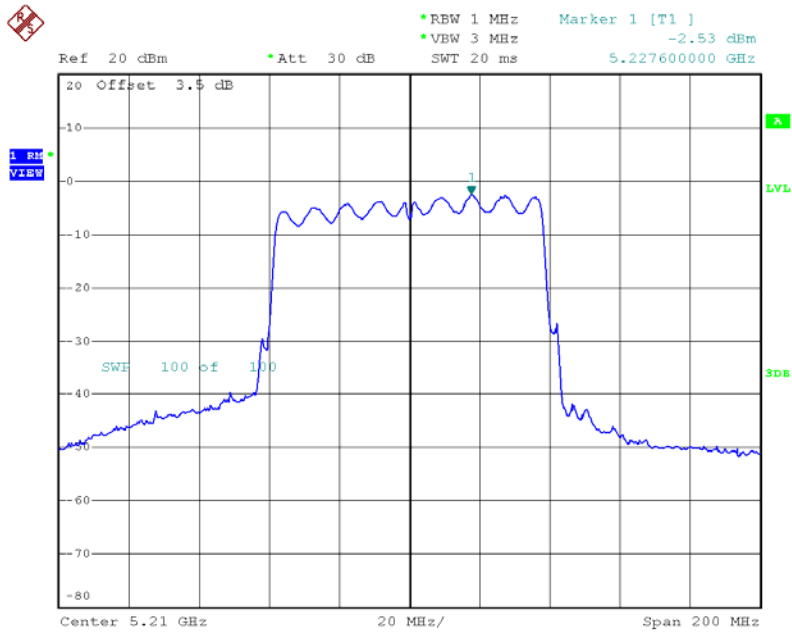

Date: 30.OCT.2016 15:37:15

802.11a Mode					
Frequency (MHz)	Power Density (dBm/MHz)			Limit (dBm/500KHz)	Result
	ANT 0	ANT 1	Total		
5745	0.25		-2.76	30	Pass
5785	-0.03		-3.04		
5825	0.16		-2.85		
Remark: Bandwidth factor=-3.01 dBm					

802.11a Mode 5745 MHz

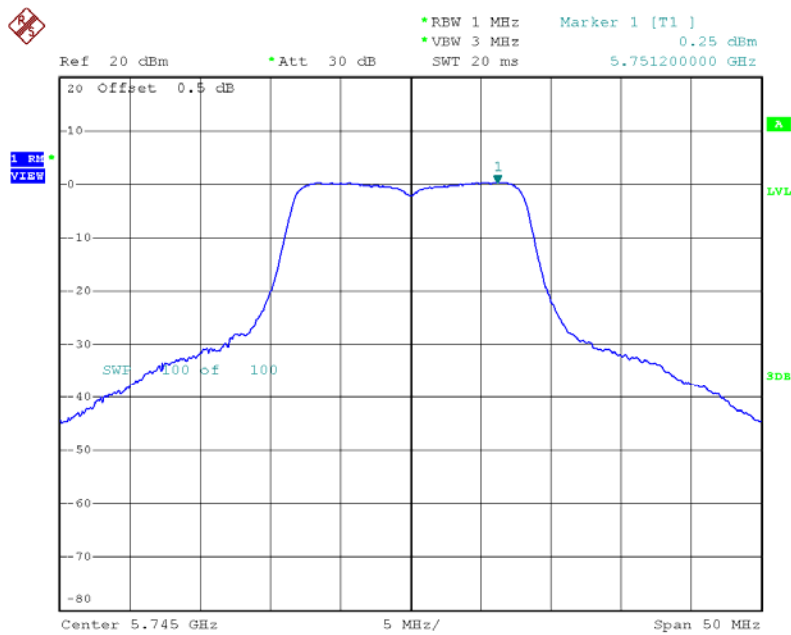

Date: 30.OCT.2016 12:25:33

802.11a Mode 5785 MHz

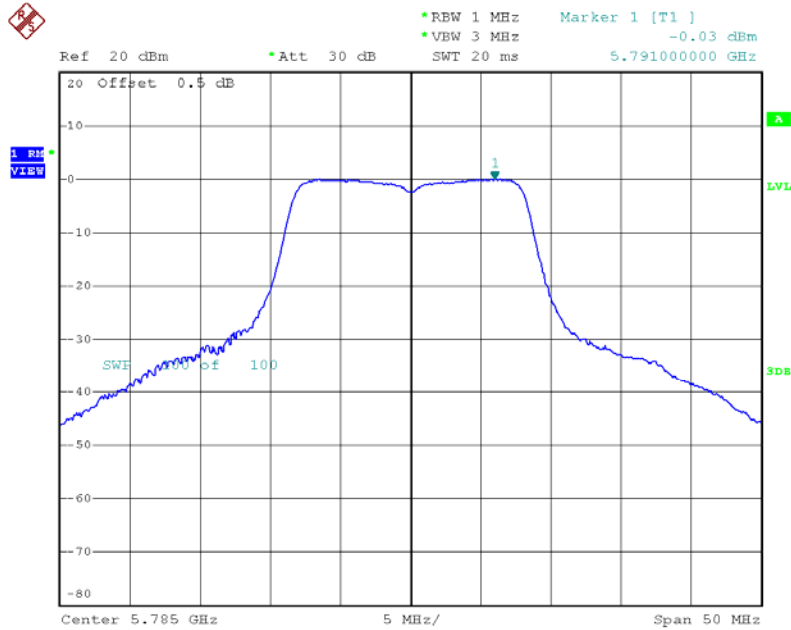

Date: 30.OCT.2016 12:27:09

802.11a Mode 5825 MHz

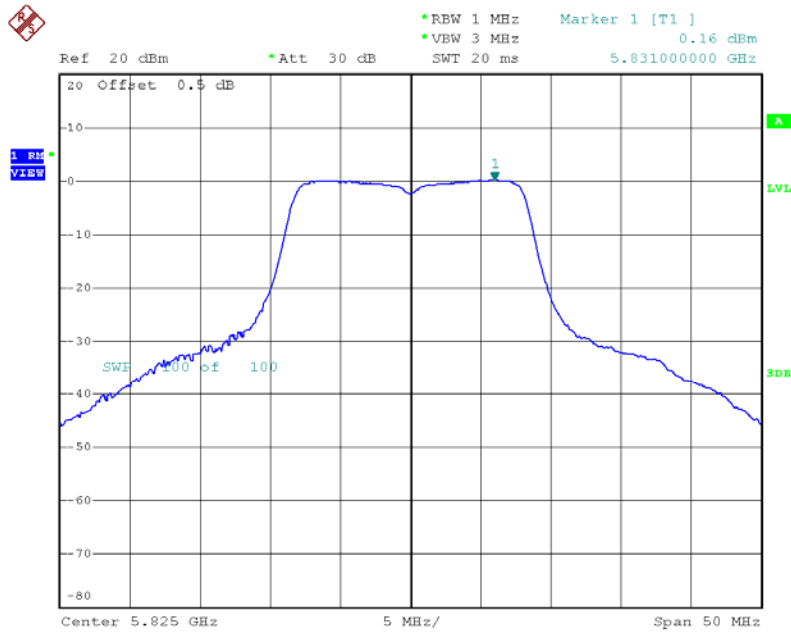

Date: 30.OCT.2016 12:28:04

802.11n(20) Mode					
Frequency (MHz)	Power Density(dBm/MHz)			Limit (dBm/500KHz)	Result
	ANT 0	ANT 1	Total		
5745	0.32	0.30	0.31	30	Pass
5785	0.97	0.78	0.87		
5825	1.92	1.22	1.58		

Remark: Bandwidth factor=-3.01 dBm

802.11n(HT20) Mode 5745 MHz-ANT 0

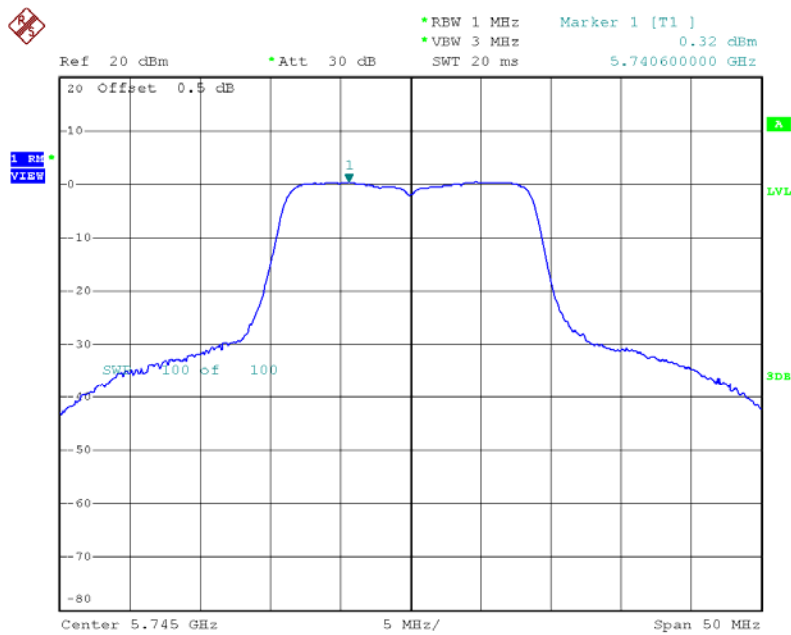

Date: 30.OCT.2016 14:29:47

802.11n(HT20) Mode 5785 MHz-ANT 0

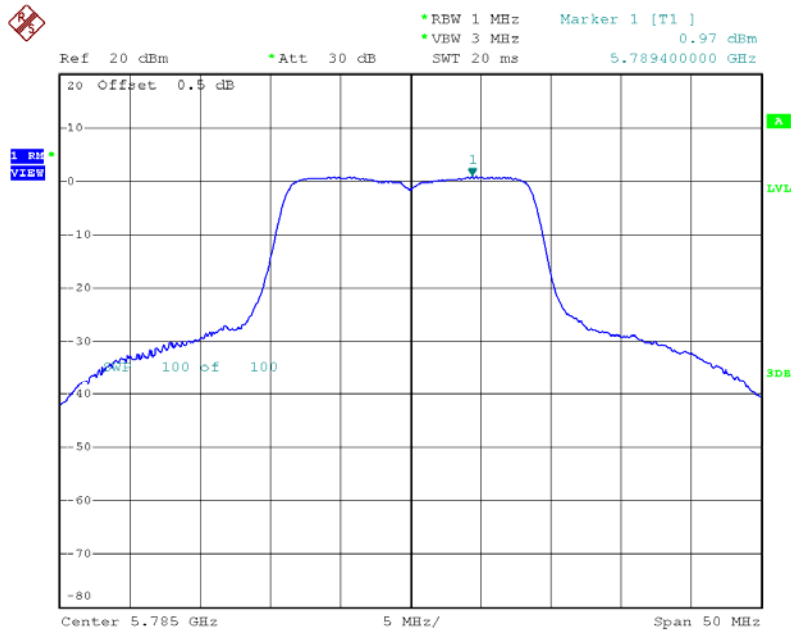

Date: 30.OCT.2016 14:35:15

802.11n(HT20) Mode 5825 MHz-ANT 0

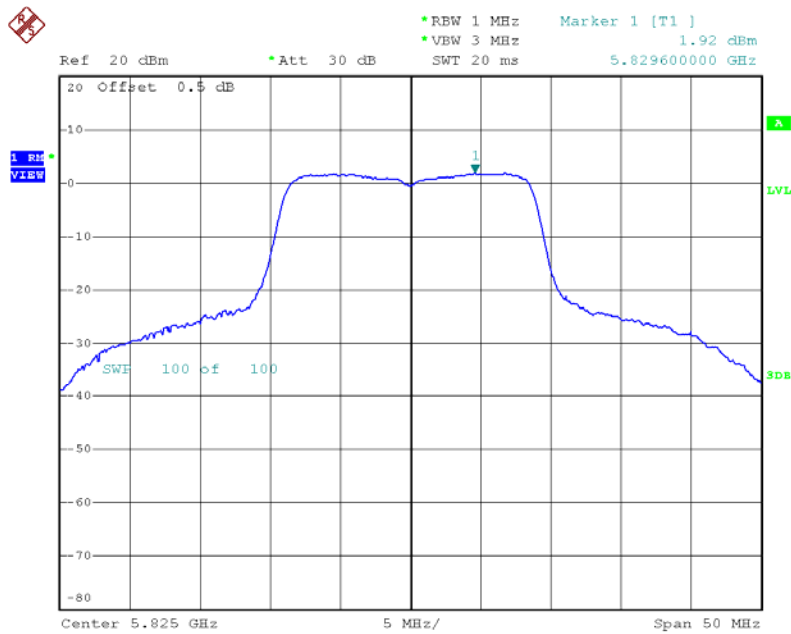

Date: 30.OCT.2016 14:36:25

802.11n(HT20) Mode 5745 MHz-ANT 1

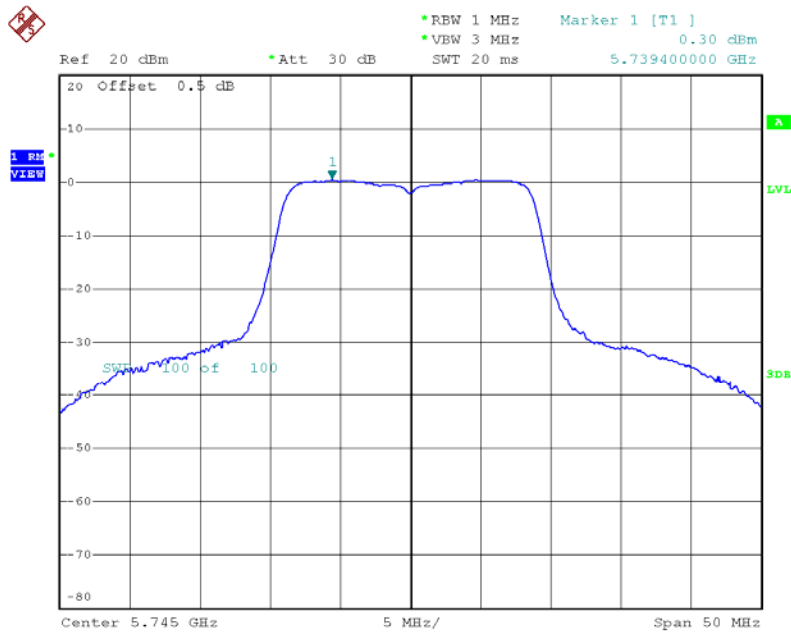

Date: 30.OCT.2016 16:24:01

802.11n(HT20) Mode 5785 MHz-ANT 1

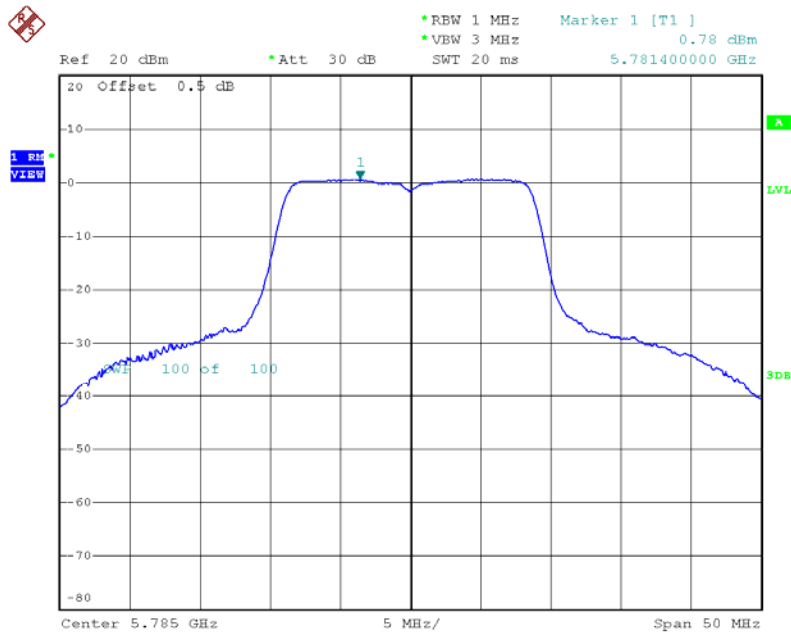

Date: 30.OCT.2016 16:28:43

802.11n(HT20) Mode 5825 MHz-ANT 1

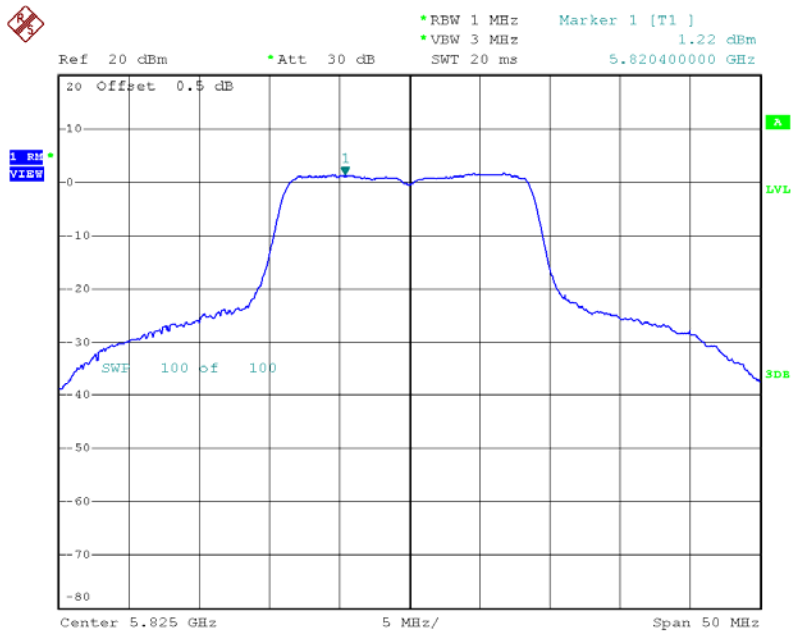

Date: 30.OCT.2016 16:34:25

802.11ac(20) Mode					
Frequency (MHz)	Power Density(dBm/MHz)			Limit (dBm/500KHz)	Result
	ANT 0	ANT 1	Total		
5745	2.53	2.30	2.41	30	Pass
5785	2.46	2.04	2.25		
5825	2.73	1.95	2.35		

Remark: Bandwidth factor=-3.01 dBm

802.11ac(20) Mode 5745 MHz-ANT 0

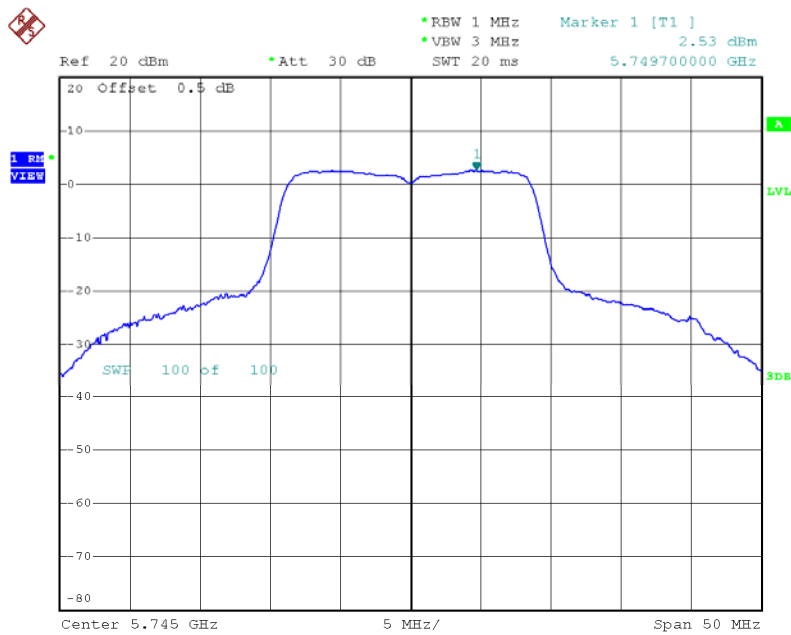

Date: 30.OCT.2016 14:50:37

802.11ac(20) Mode 5785 MHz-ANT 0

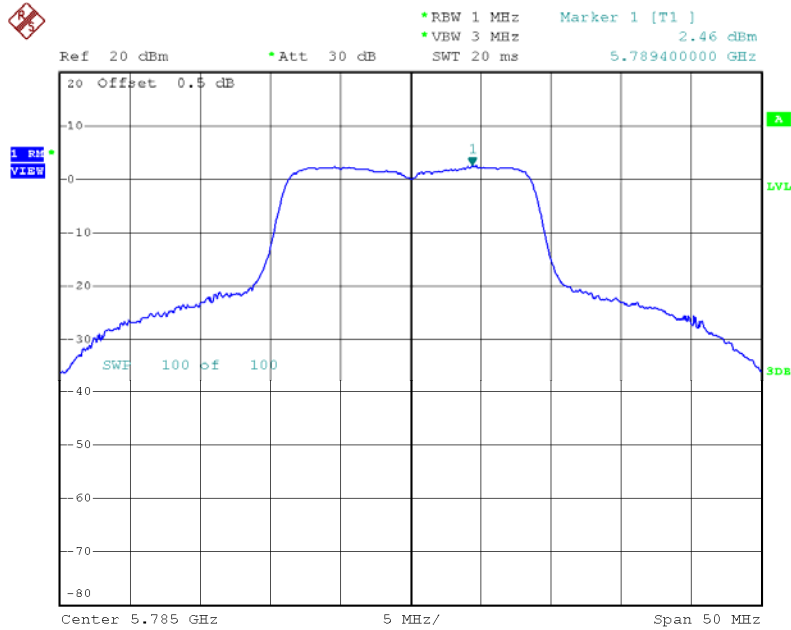

Date: 30.OCT.2016 14:54:48

802.11ac(20) Mode 5825 MHz-ANT 0

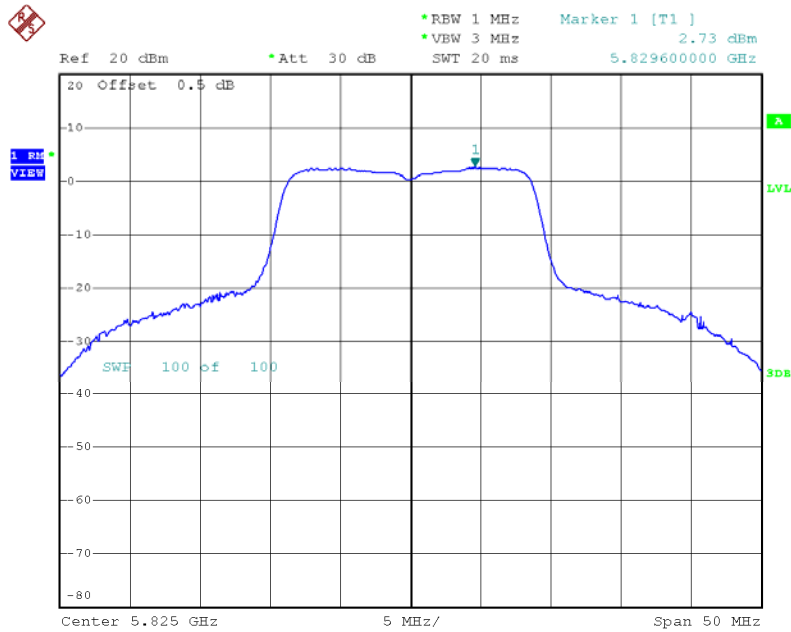

Date: 30.OCT.2016 14:55:47

802.11ac(20) Mode 5745 MHz-ANT 1

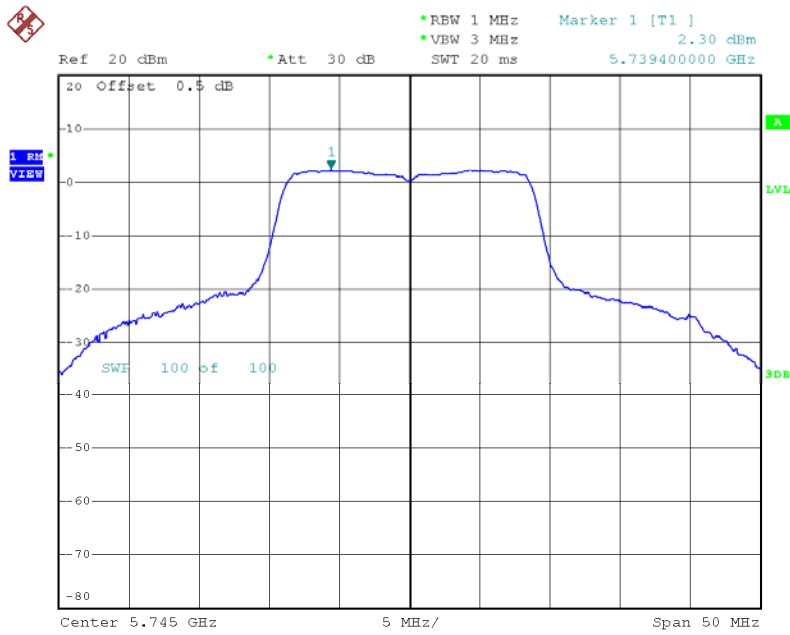

Date: 30.OCT.2016 17:21:36

802.11ac(20) Mode 5785 MHz-ANT 1

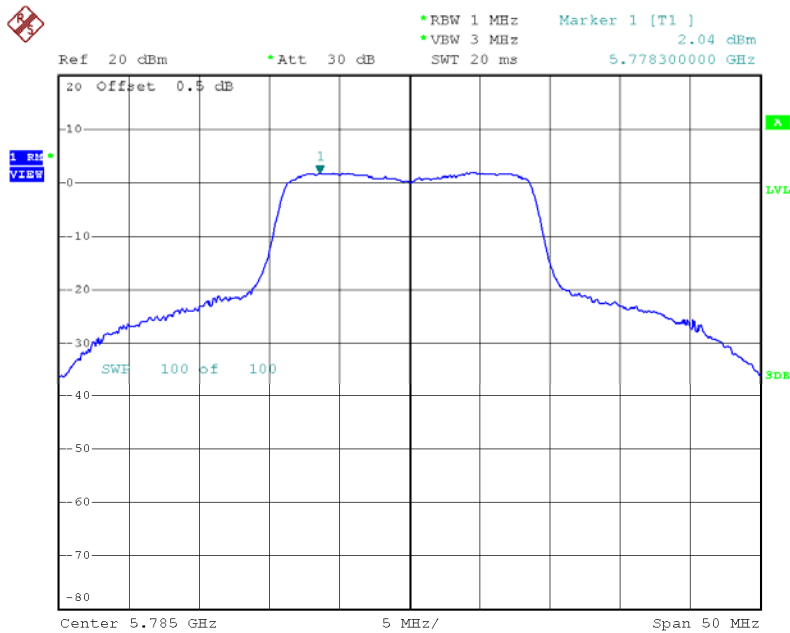

Date: 30.OCT.2016 17:17:21

802.11ac(20) Mode 5825 MHz-ANT 1

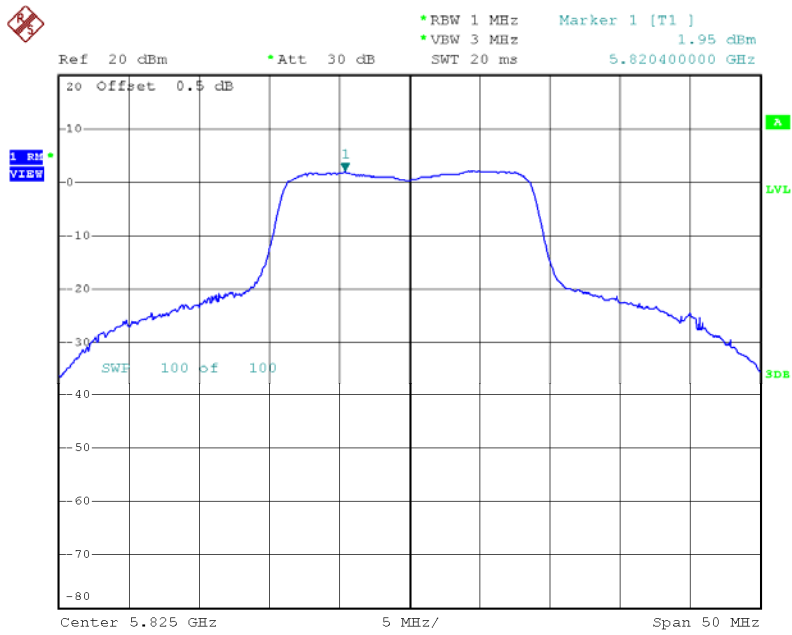

Date: 30.OCT.2016 17:22:38

802.11n(40) Mode					
Frequency (MHz)	Power Density (dBm/MHz)			Limit (dBm/500KHz)	Result
	ANT 0	ANT 1	Total		
5755	-0.49	-0.75	-0.61	30	Pass
5795	0.19	-0.12	0.03		

Remark: Bandwidth factor=-3.01 dBm

802.11n(HT40) Mode 5755 MHz-ANT 0

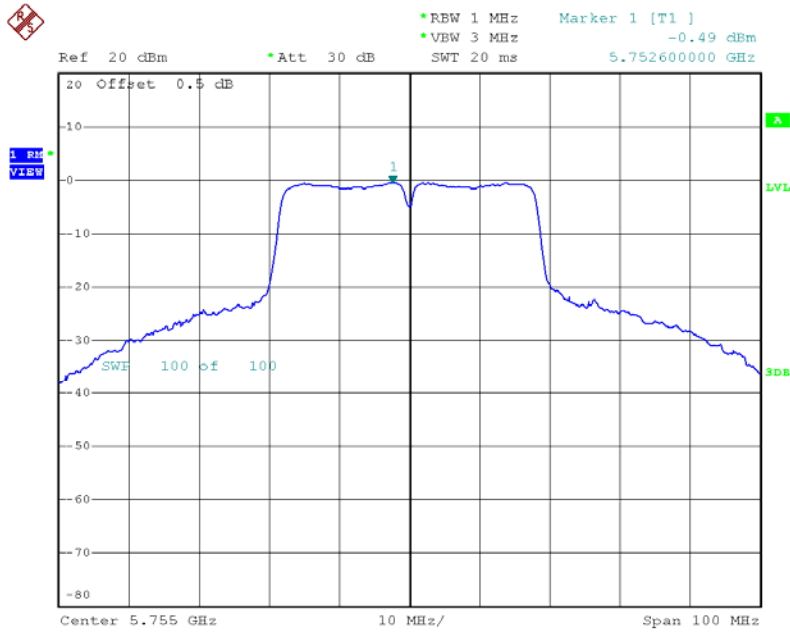

Date: 30.OCT.2016 15:02:09

802.11n(HT40) Mode 5795 MHz-ANT 0

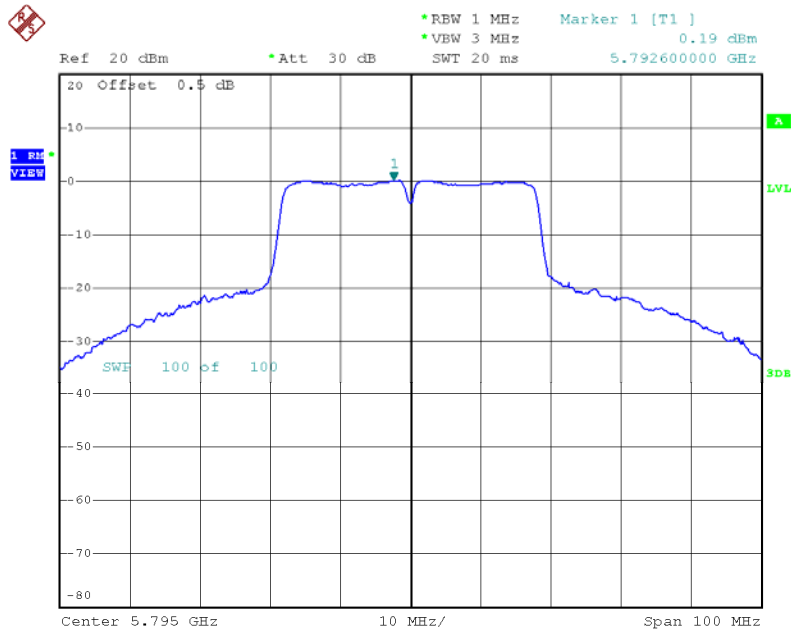

Date: 30.OCT.2016 15:06:35

802.11n(HT40) Mode 5755 MHz-ANT 1

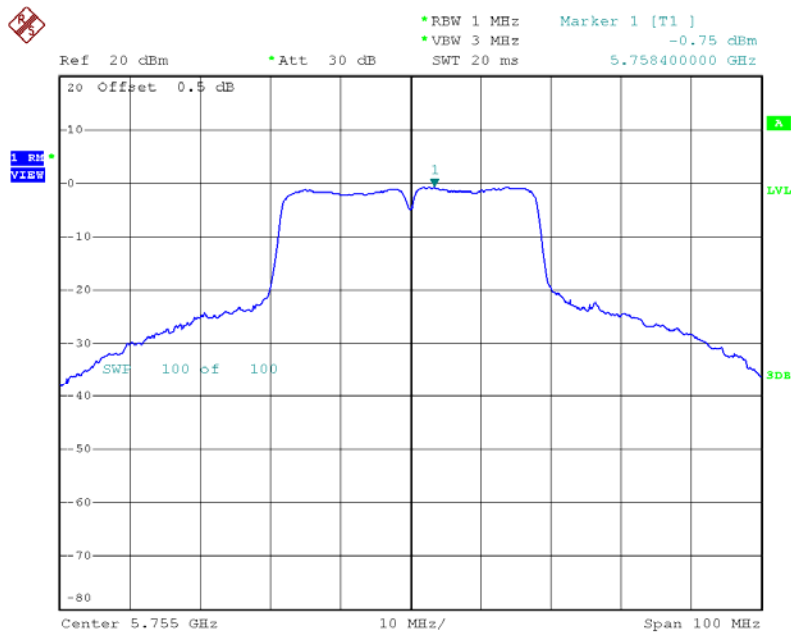

Date: 30.OCT.2016 17:24:52

802.11n(HT40) Mode 5795 MHz-ANT 1

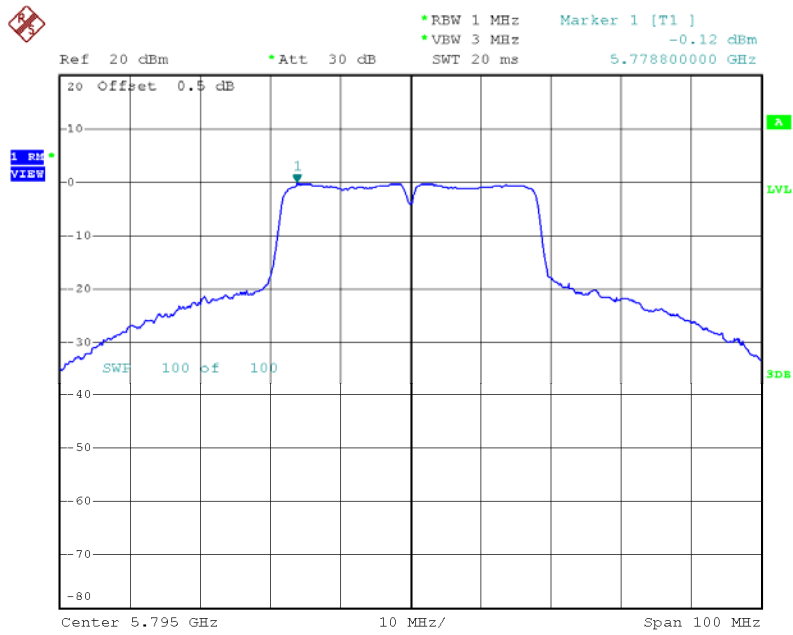

Date: 30.OCT.2016 17:26:59

802.11ac(40) Mode					
Frequency (MHz)	Power Density (dBm/MHz)			Limit (dBm/500KHz)	Result
	ANT 0	ANT 1	Total		
5755	-0.58	-0.78	-0.67	30	Pass
5795	-0.59	-0.92	-0.75		

Remark: Bandwidth factor=-3.01 dBm

802.11ac(40) Mode 5755 MHz-ANT 0

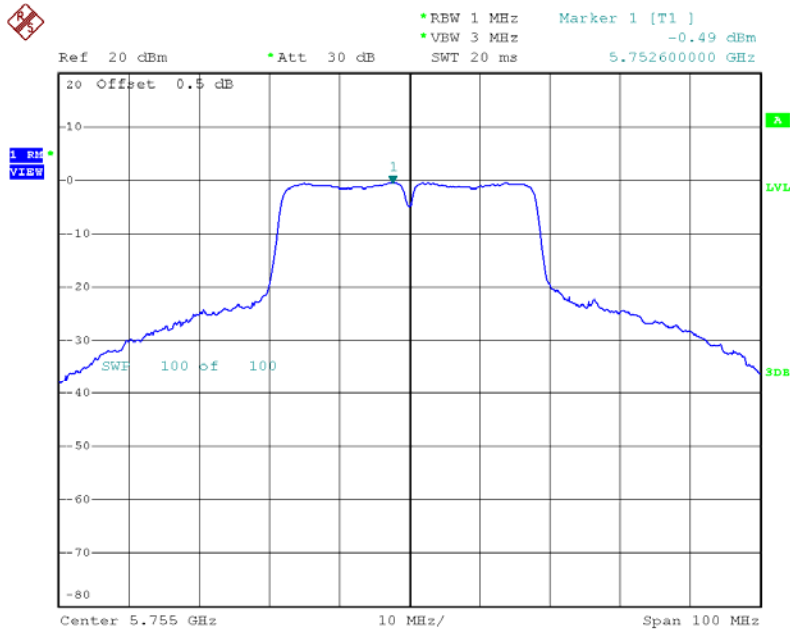

Date: 30.OCT.2016 15:02:09

802.11ac(40) Mode 5795 MHz-ANT 0

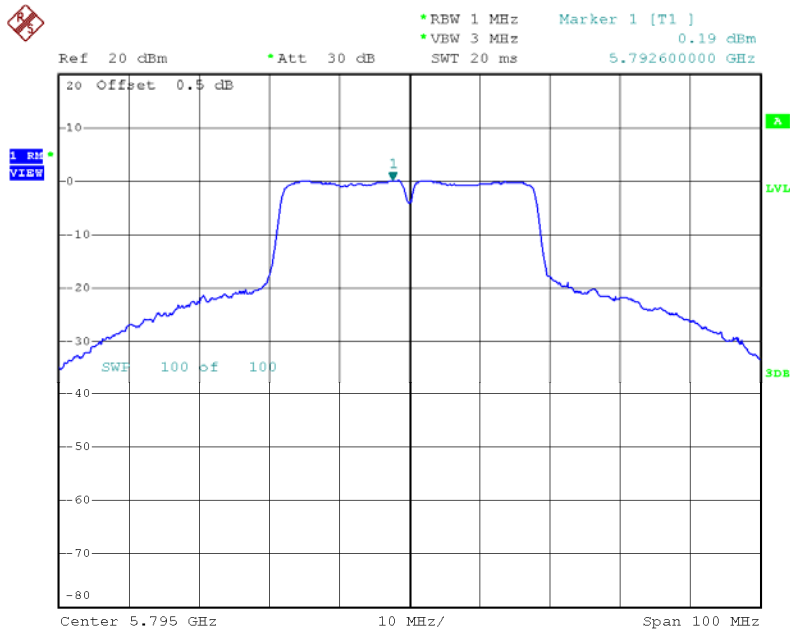

Date: 30.OCT.2016 15:06:35

802.11ac(40) Mode 5755 MHz-ANT 1

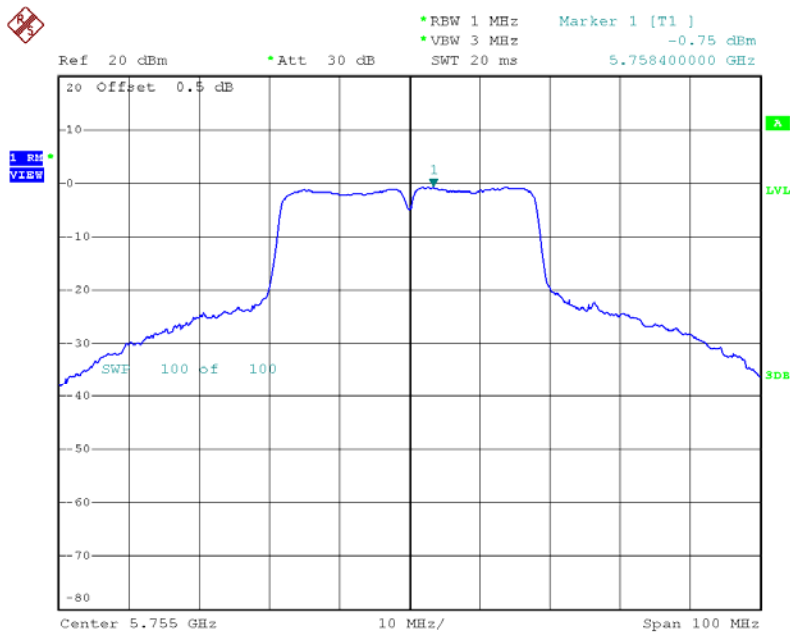

Date: 30.OCT.2016 17:24:52

802.11ac(40) Mode 5795 MHz-ANT 1

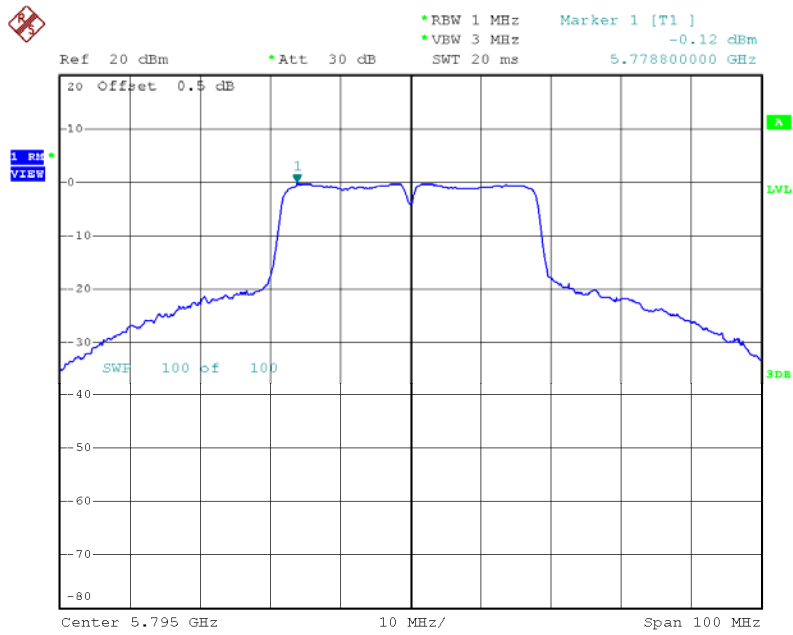

Date: 30.OCT.2016 17:26:59

802.11ac(80) Mode					
Frequency (MHz)	Power Density (dBm/MHz)			Limit (dBm/500KHz)	Result
	ANT 0	ANT 1	Total		
5775	-3.31	-3.94	-3.61	30	Pass
Remark: Bandwidth factor=-3.01 dBm					

802.11ac(80) Mode 5775 MHz-ANT 0

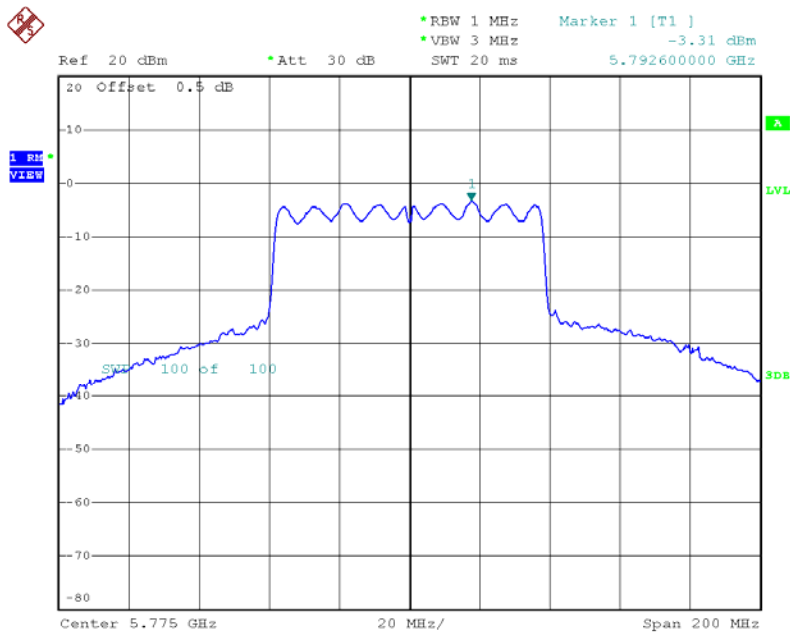

Date: 30.OCT.2016 15:41:44

802.11ac(80) Mode 5775 MHz-ANT 1

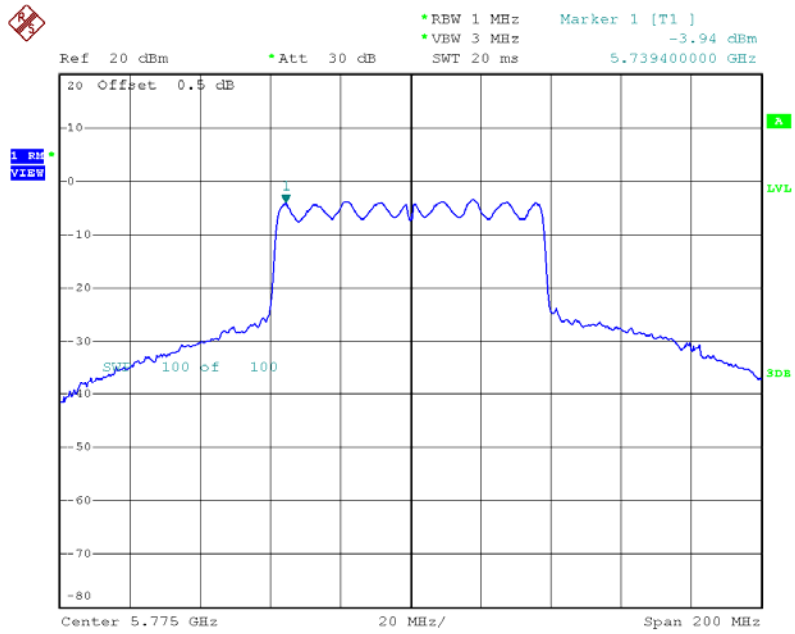

Date: 30.OCT.2016 17:33:08

8. BAND EDGE EMISSION

8.1 LIMITS

FCC Part 15.407, Subpart E/RSS 247	
Frequency Range (MHz)	Limits
5150~5250	-27 dBm/MHz
5725~5850	Below -17 dBm/MHz within 10MHz of band edge, below -27 dBm/MHz beyond 10MHz

8.2 TEST PROCEDURE

The EUT was directly connected to the power meter and antenna output port as show in the block diagram as bellow.

Spectrum Parameters	Setting
Attenuation	Auto
RBW	1 MHz
VBW	3 MHz
Detector	Peak
Trace	Max Hold
Sweep Time	Auto

8.3 TEST SETUP

Conducted Emission Test Setup

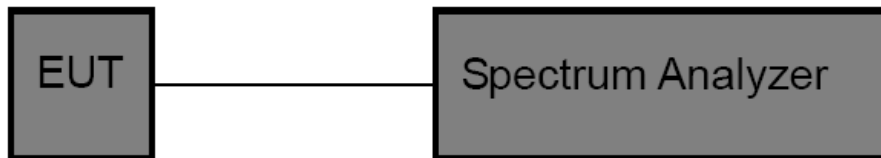

8.4 TEST INSTRUMENTS

Equipment	Manufacturer	Type No.	Serial No.	Last calibration	Calibrated until	Calibration period
Spectrum Analyzer	R&S	FSP40	100154	Jul. 04. 2016	Jul. 03. 2017	1 year

8.5 EUT OPERATING CONDITIONS

The EUT was set to continuously transmitting in the maximum power during the test.

8.6 TEST RESULTS

Only showed the worst mode data of ANT 0 transmitting.

802.11a Mode CH36

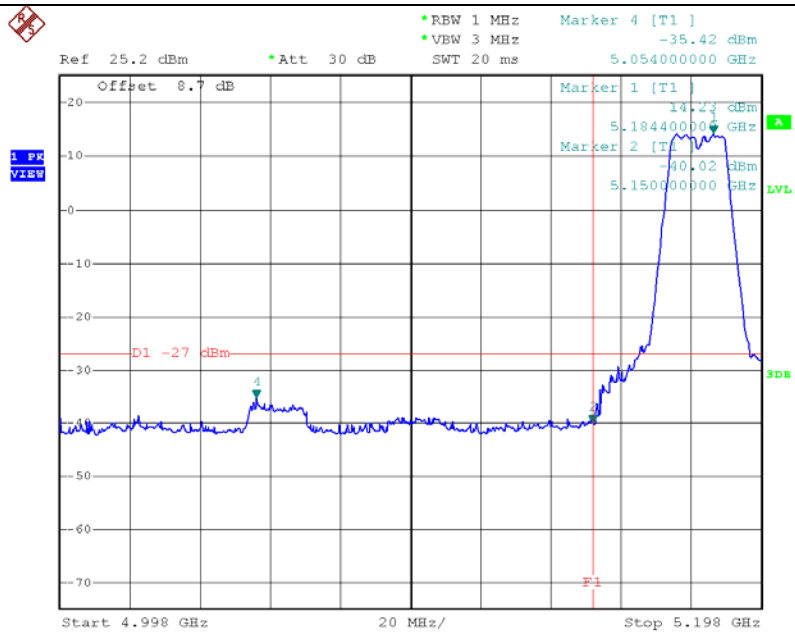

Date: 30.OCT.2016 12:22:49

802.11a Mode CH48

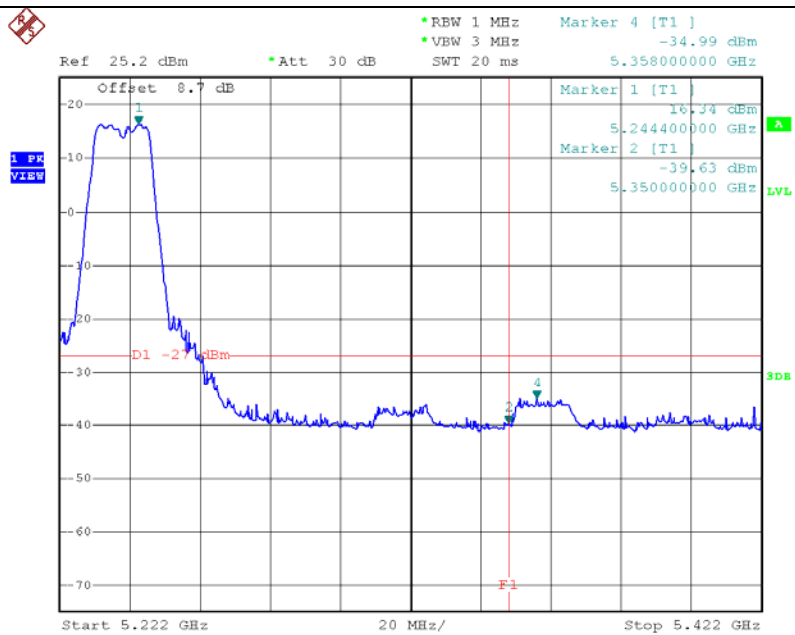

Date: 30.OCT.2016 12:24:59

802.11n(HT20) Mode CH36

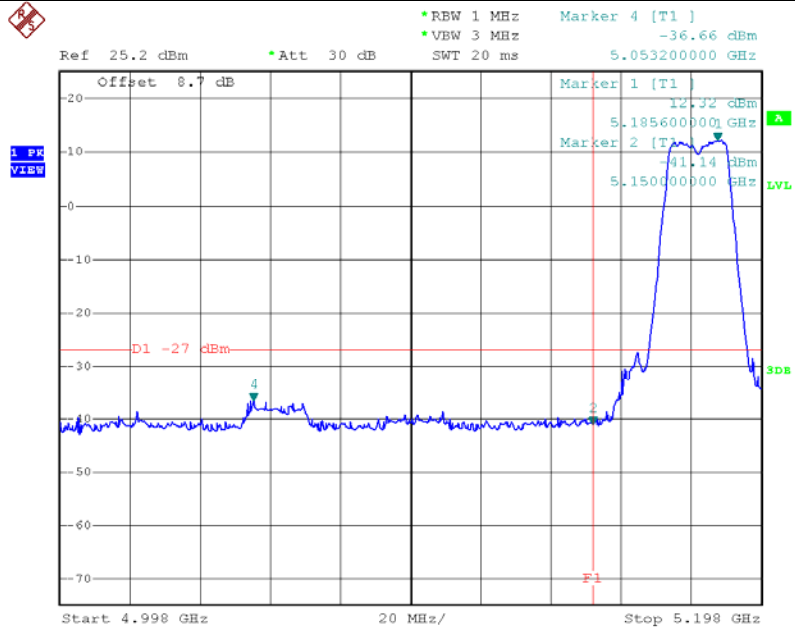

Date: 30.OCT.2016 12:29:36

802.11n(HT20) Mode CH48

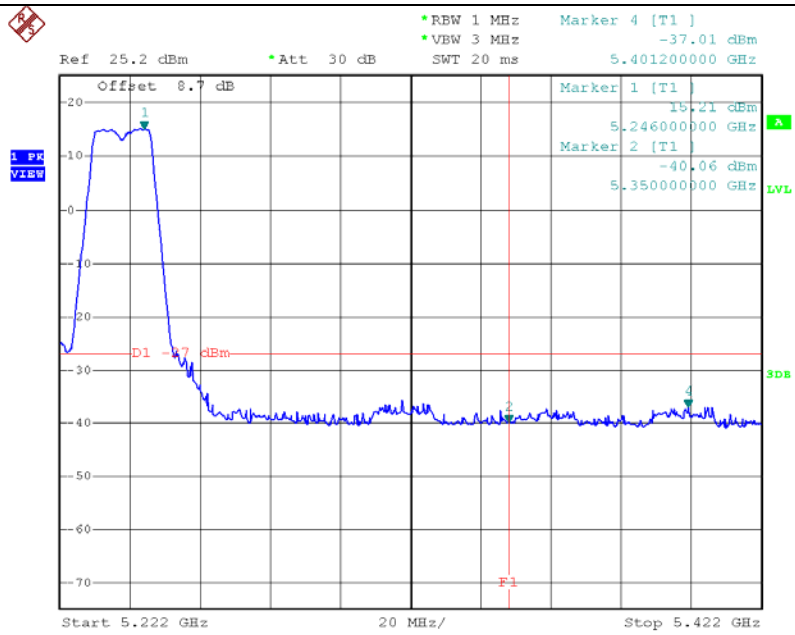

Date: 30.OCT.2016 14:28:48

802.11ac(20) Mode CH36

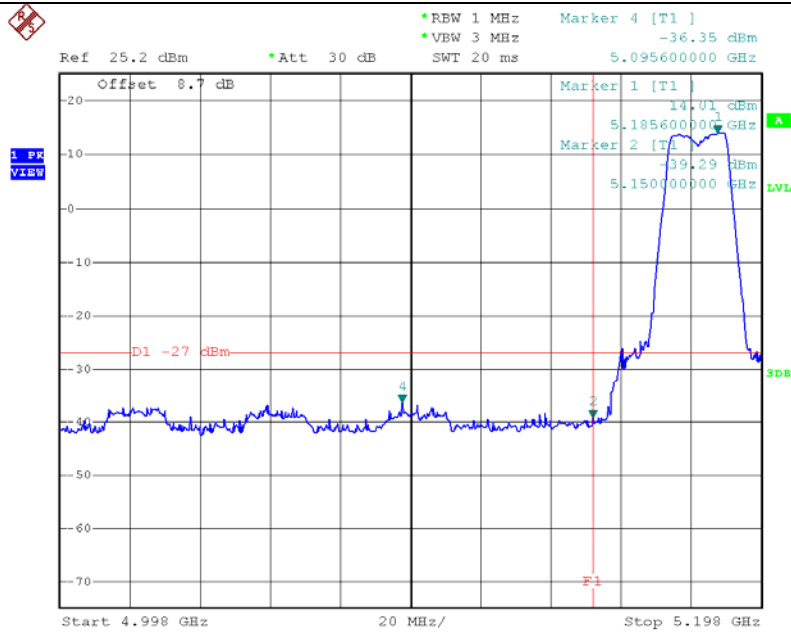

Date: 30.OCT.2016 14:47:39

802.11ac(20) Mode CH48

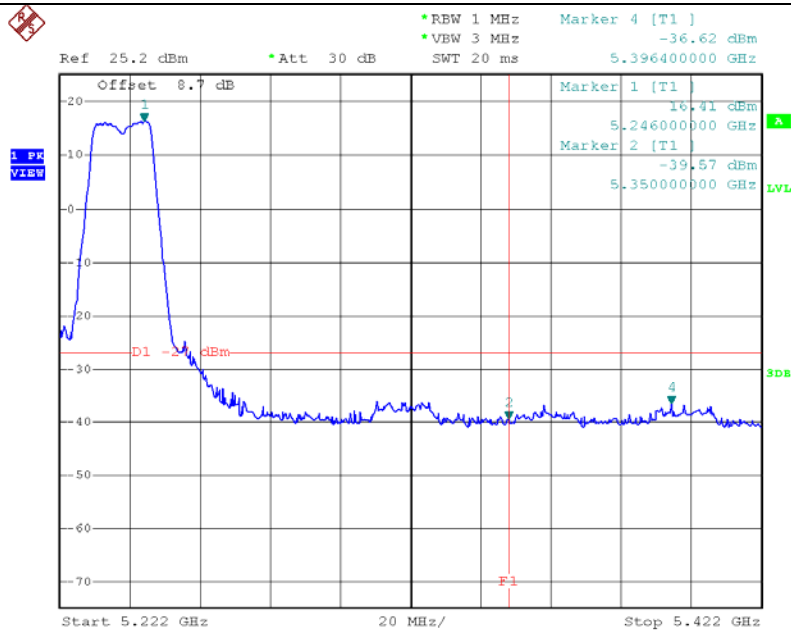

Date: 30.OCT.2016 14:49:43

802.11n(HT40) Mode CH38

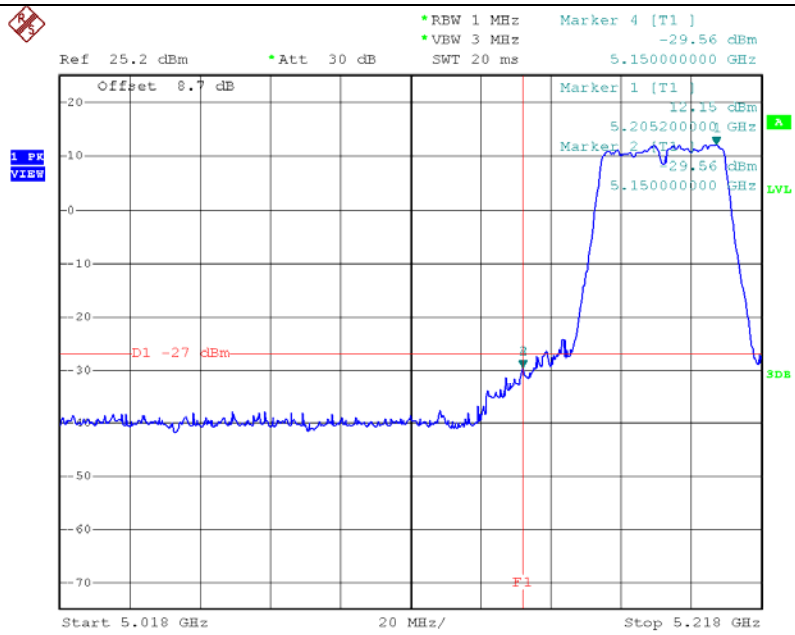

Date: 30.OCT.2016 14:59:53

802.11n(HT40) Mode CH46

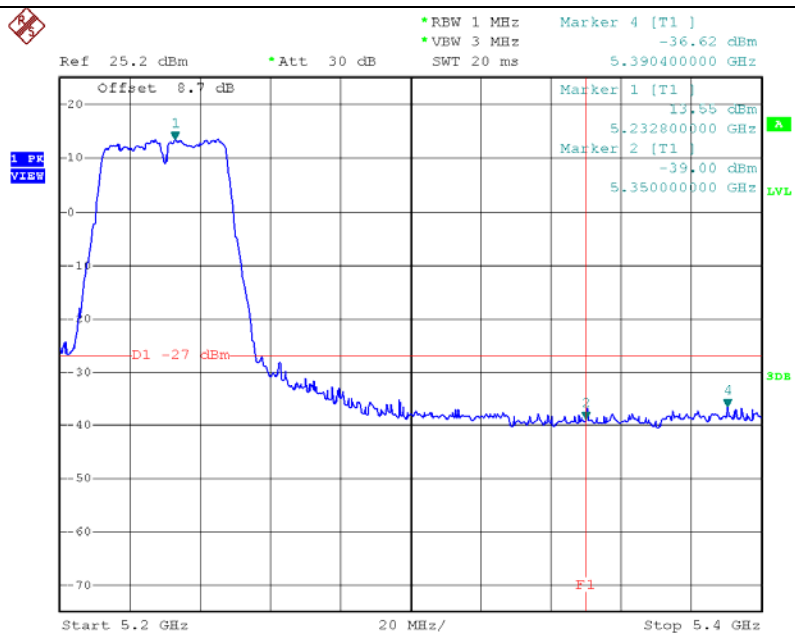

Date: 30.OCT.2016 15:01:06

802.11ac(40) Mode CH38

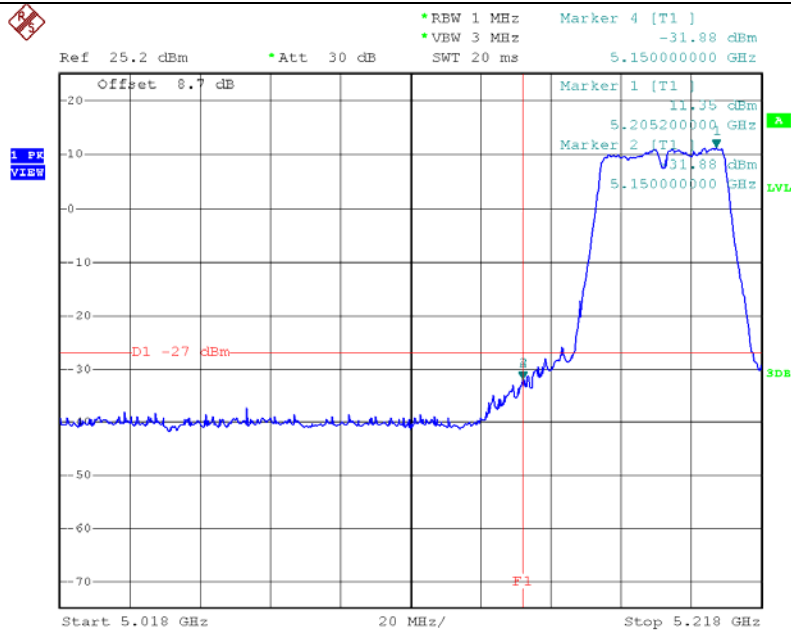

Date: 30.OCT.2016 15:11:02

802.11ac(40) Mode CH46

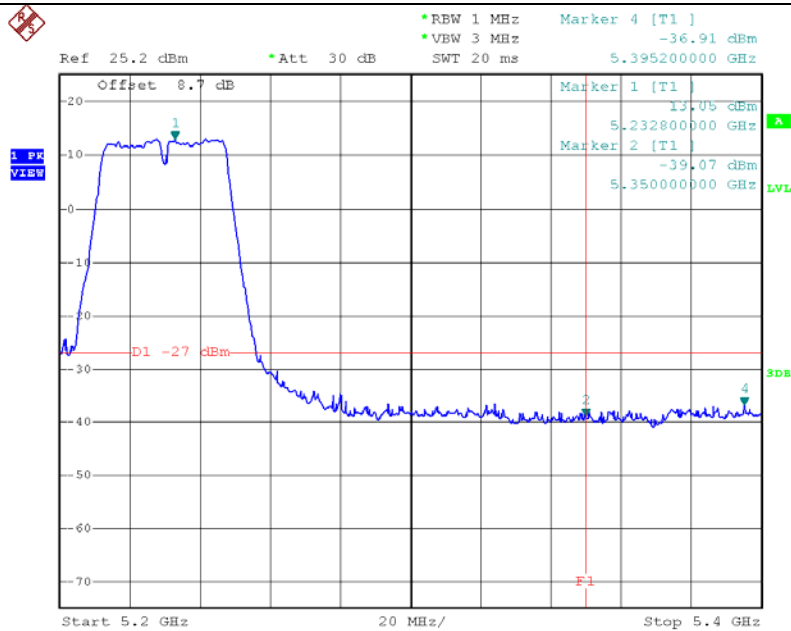

Date: 30.OCT.2016 15:12:11

802.11ac(80) Mode CH42

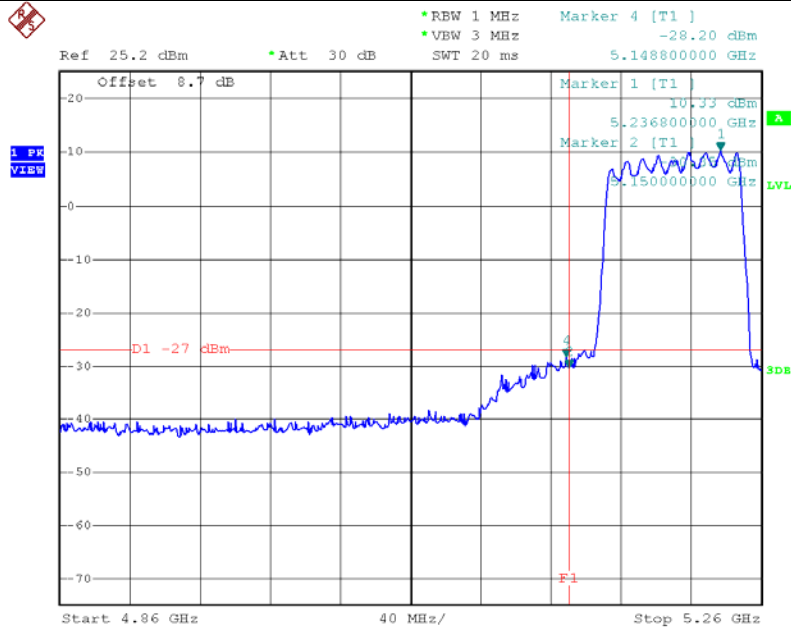

Date: 30.OCT.2016 15:37:23

802.11ac(80) Mode CH42

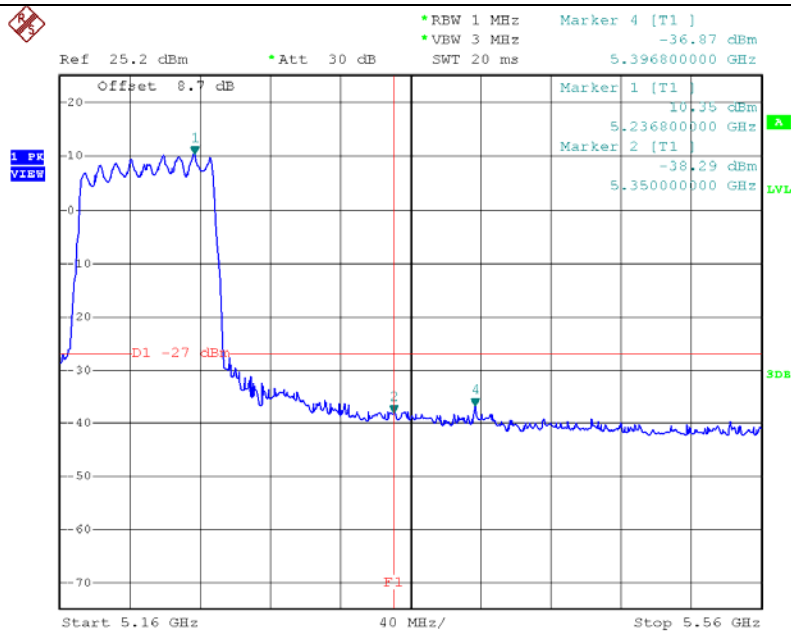

Date: 30.OCT.2016 15:37:30

802.11a Mode CH149

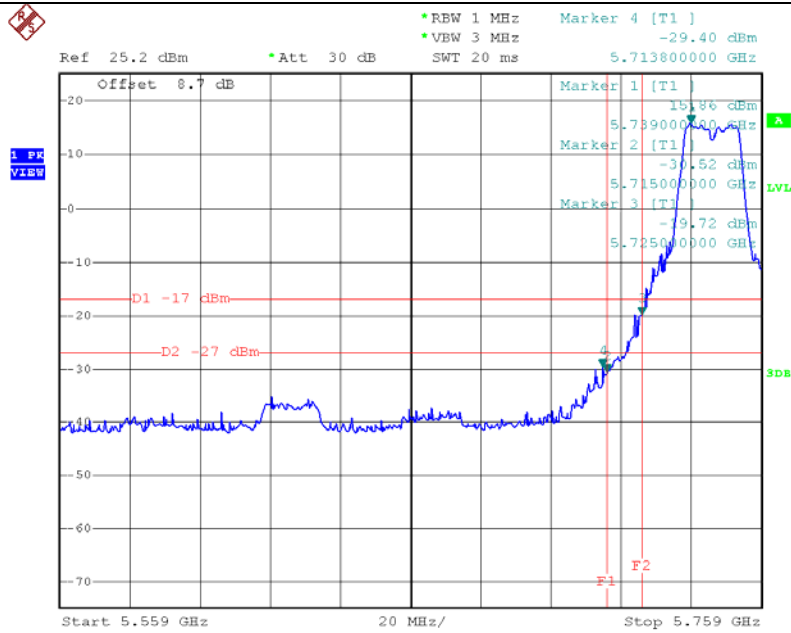

Date: 30.OCT.2016 12:26:13

802.11a Mode CH165

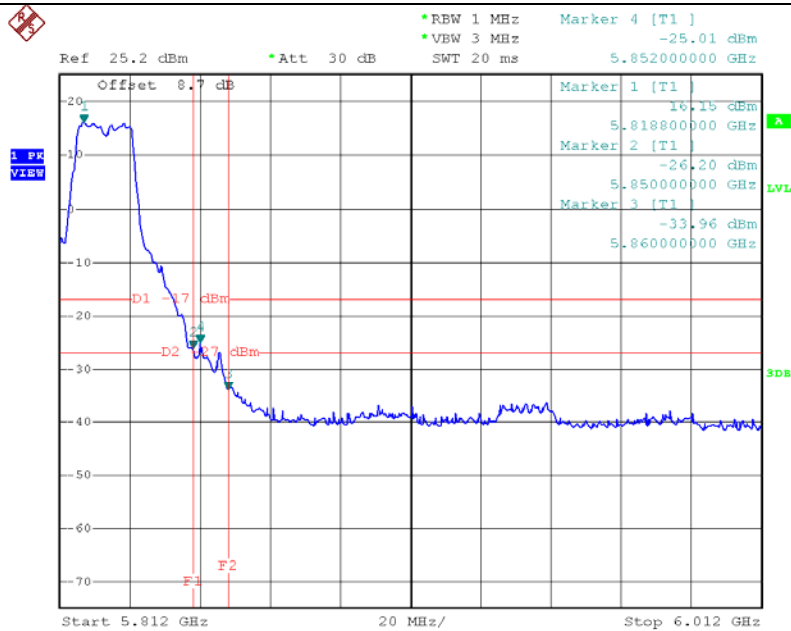

Date: 30.OCT.2016 12:28:11

802.11n(HT20) Mode CH149

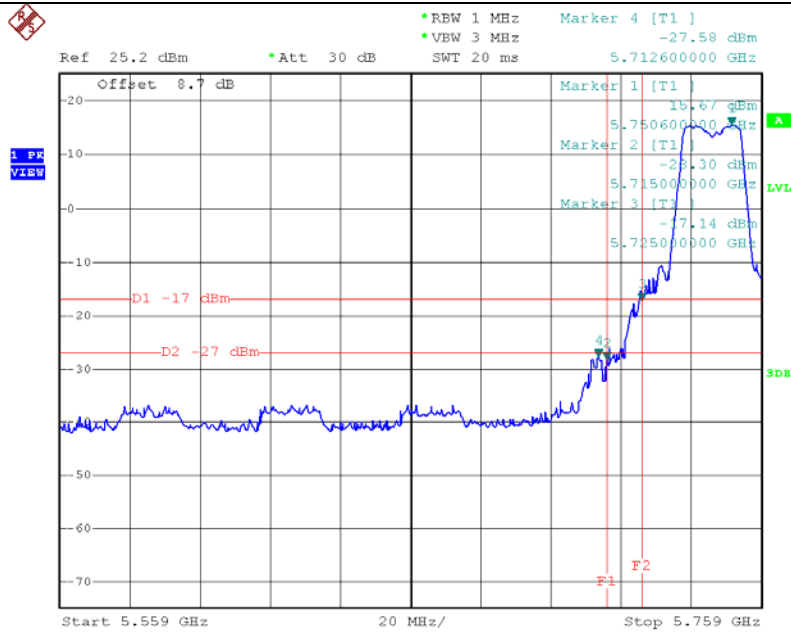

Date: 30.OCT.2016 14:32:28

802.11n(HT20) Mode CH165

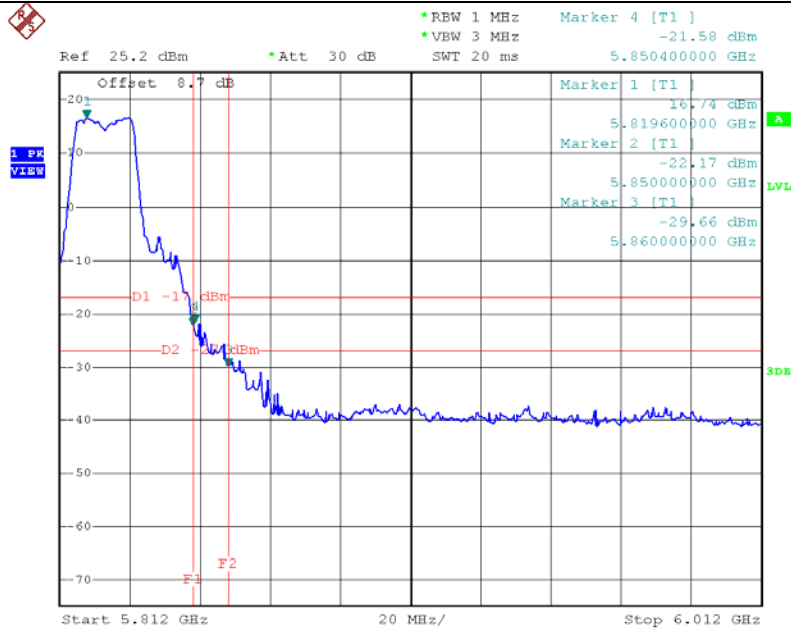

Date: 30.OCT.2016 14:44:24

802.11ac(20) Mode CH149

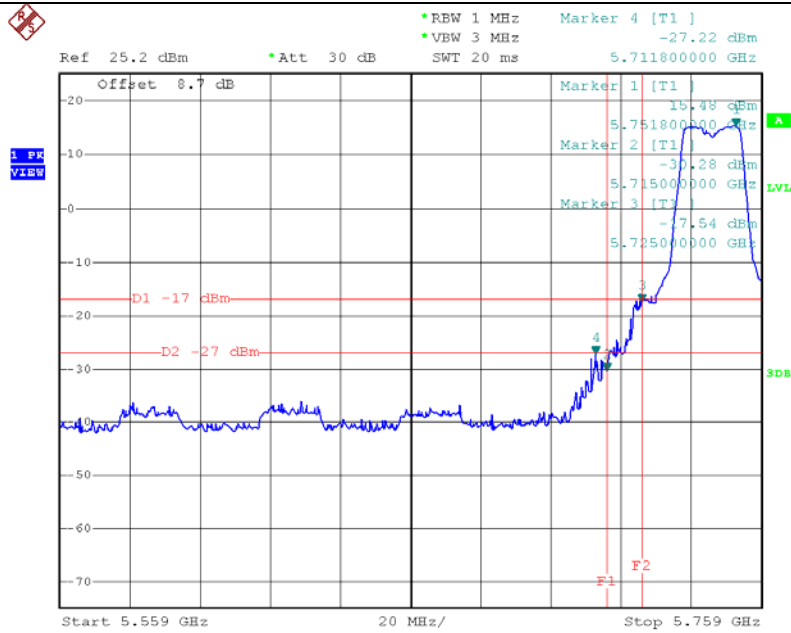

Date: 30.OCT.2016 14:53:16

802.11ac(20) Mode CH165

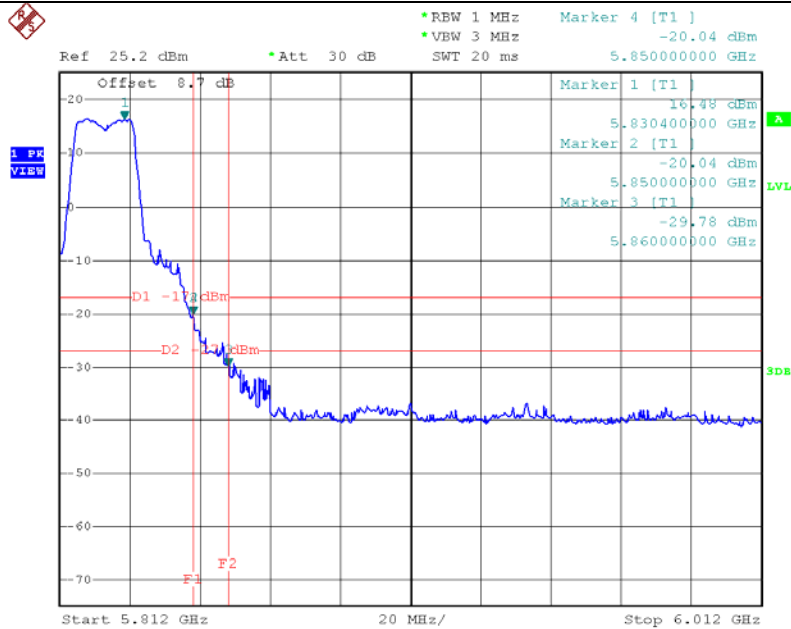

Date: 30.OCT.2016 14:56:38

802.11n(HT40) Mode CH151

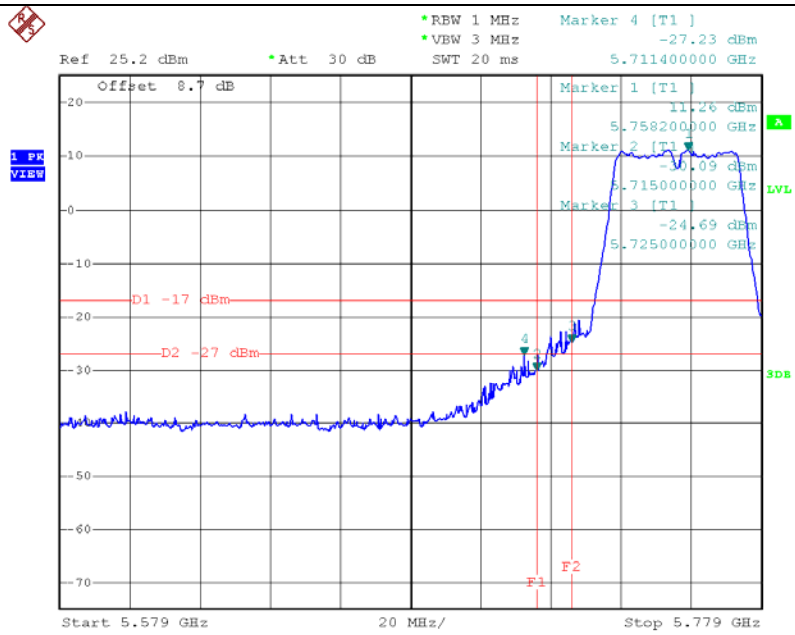

Date: 30.OCT.2016 15:03:38

802.11n(HT40) Mode CH159

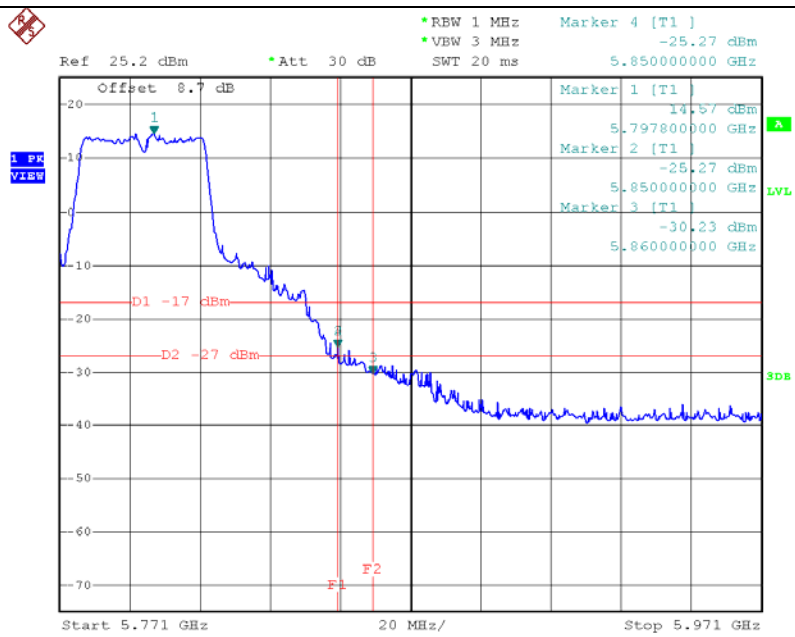

Date: 30.OCT.2016 15:08:23

802.11ac(40) Mode CH151

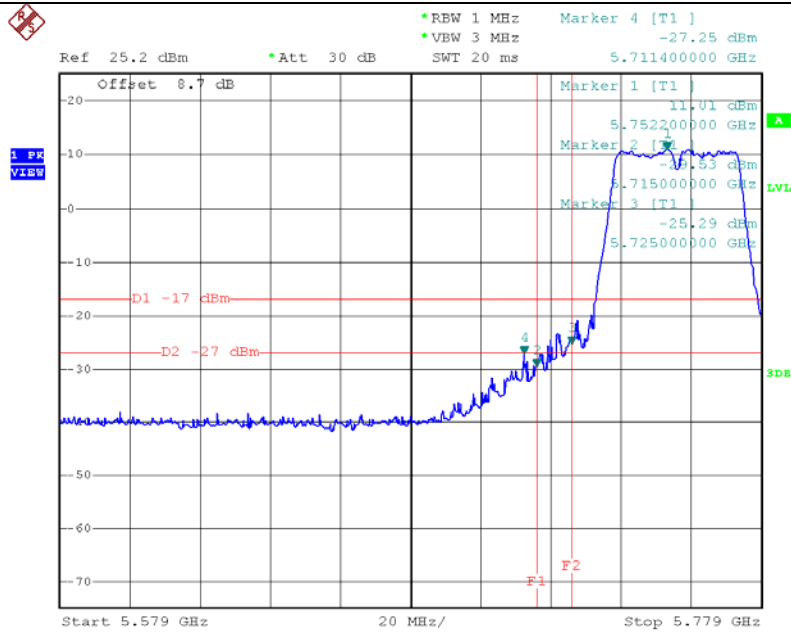

Date: 30.OCT.2016 15:14:23

802.11ac(40) Mode CH159

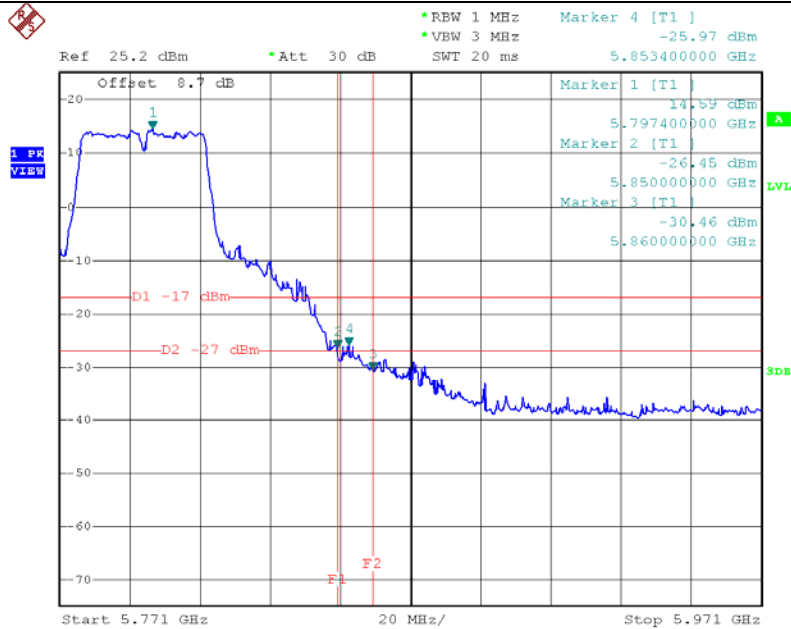

Date: 30.OCT.2016 15:18:02

802.11ac(80) Mode CH155

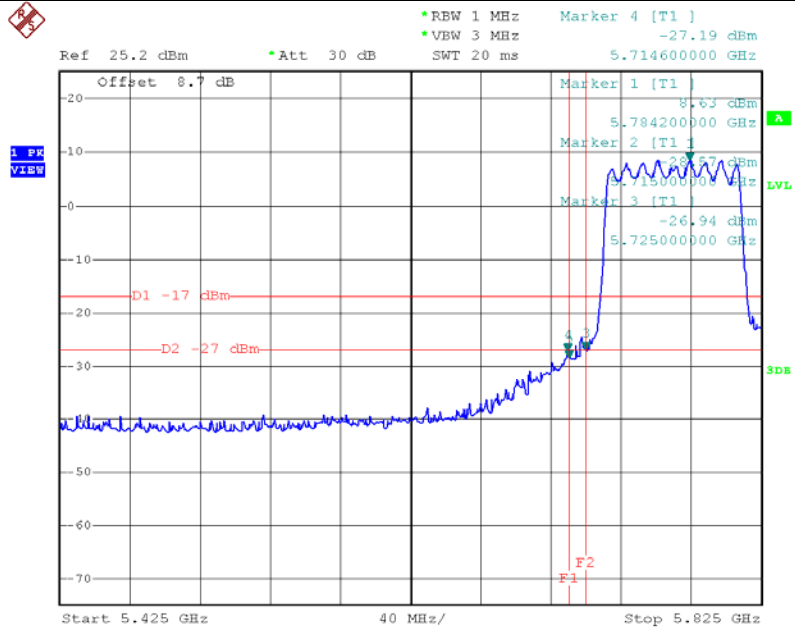

Date: 30.OCT.2016 15:48:49

802.11ac(80) Mode CH155

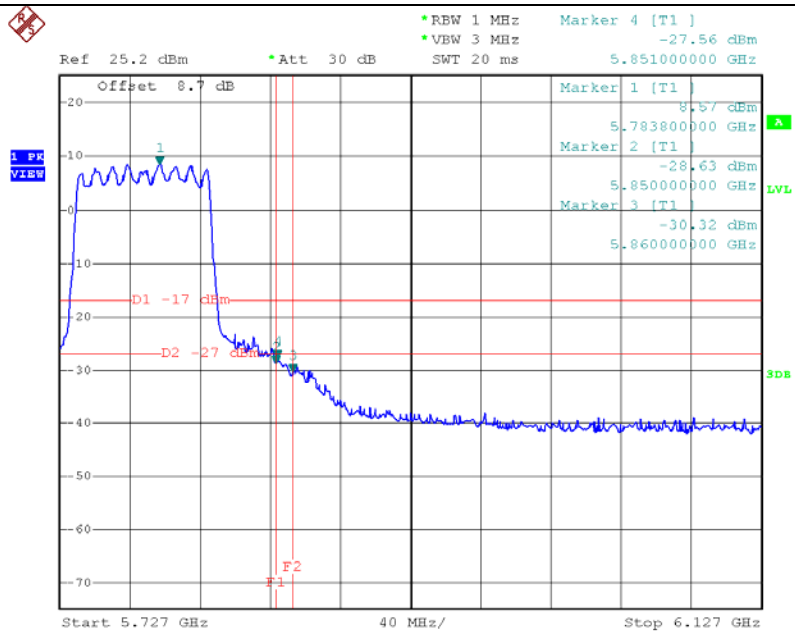

Date: 30.OCT.2016 15:48:57

9. ANTENNA REQUIREMENT

9.1 LIMITS

FCC Part 15.407, Subpart E/RSS 247	
Frequency Range (MHz)	Limits
5150~5250	Specified in the user's manual, the center frequency tolerance shall be ± 20 ppm maximum for the 5GHz band.
5725~5850	

9.2 TEST PROCEDURE

The EUT was directly connected to the power meter and antenna output port as show in the block diagram as bellow.

Spectrum Parameters	Setting
Attenuation	Auto
Span	Entire absence of modulation emissions bandwidth
RBW	10 kHz
VBW	10 kHz
Detector	Peak
Trace	Max Hold
Sweep Time	Auto

The test extreme voltage is to change the primary supply voltage from 85 to 115 percent of the nominal value.

User manual temperature is 0°C~50°C

9.3 TEST SETUP

Conducted Emission Test Setup

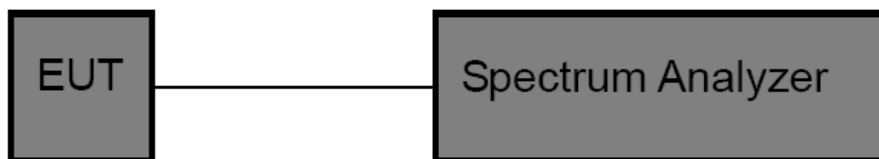

9.4 TEST INSTRUMENTS

Equipment	Manufacturer	Type No.	Serial No.	Last calibration	Calibrated until	Calibration period
Spectrum Analyzer	R&S	FSP40	100154	Jul. 04. 2016	Jul. 03. 2017	1 year

9.5 EUT OPERATING CONDITIONS

The EUT was set to continuously transmitting in the maximum power during the test.

9.6 TEST RESULTS

5150~5250 Band (5180MHz)	
Voltage vs. Frequency Stability	
Voltage (V)	Measurement Frequency (MHz)
132	5179.9683
120	5179.9676
118	5179.9665
Max. Deviation (MHz)	0.0335
Max. Deviation (ppm)	6.47
Temperature vs. Frequency Stability	
Temperature (°C)	Measurement Frequency (MHz)
0	5179.9677
10	5179.9671
20	5179.9665
30	5179.9660
40	5179.9667
50	5179.9663
Max. Deviation (MHz)	0.0339
Max. Deviation (ppm)	6.56

5725~5850 Band (5745MHz)	
Voltage vs. Frequency Stability	
Voltage (V)	Measurement Frequency (MHz)
132	5744.9789
120	5744.9787
118	5744.9790
Max. Deviation (MHz)	0.0213
Max. Deviation (ppm)	3.71
Temperature vs. Frequency Stability	
Temperature (°C)	Measurement Frequency (MHz)
0	5744.9789
10	5744.9783
20	5744.9781
30	5744.9786
40	5744.9784
50	5744.9784
Max. Deviation (MHz)	0.0219
Max. Deviation (ppm)	3.81

10. ANTENNA REQUIREMENT

10.1 REQUIREMENT

Antenna Requirement (15.203)	An intentional radiator shall be designed to ensure that no antenna other than that furnished by the responsible party shall be used with the device. The use of a permanently attached antenna or of an antenna that uses a unique coupling to the intentional radiator shall be considered sufficient to comply with the provisions of this Section. The manufacturer may design the unit so that a broken antenna can be replaced by the user, but the use of a standard antenna jack or electrical connector is prohibited.
Antenna Requirement (15.407)	If transmitting antennas of directional gain greater than 6 dBi are used, the power shall be reduced by the amount in dB that the directional gain of the antenna exceeds 6 dBi.

10.2 ANTENNA CONNECTOR CONSTRUCTION

The EUT antenna is a PIFA Antenna. And the maximum gain of this antenna is 3.0 dBi for 5150~5250 MHz, 3.0 dBi for 5725~5850 MHz.

It complies with the standard requirement.