



**FCC 47 CFR PART 15 SUBPART C  
INDUSTRY CANADA RSS-247 ISSUE 2**

**CERTIFICATION TEST REPORT**

*For*

**WIFI+BT module**

**MODEL NUMBER: WCT0LR2201J**

**FCC ID: 2AC23-WCT0LR2201J  
IC: 12290A-WCT0LR2201J**

**REPORT NUMBER: 4788196596.1-1**

**ISSUE DATE: November 24, 2017**

*Prepared for*

**Hui Zhou Gaoshengda Technology Co.,LTD  
HuaXing RD,NO 2,ZhongKai High Technology Development  
Area,Huizhou,Guangdong, China**

*Prepared by*

**UL Verification Services (Guangzhou) Co., Ltd, Song Shan Lake Branch  
Room 101, Building 10, Innovation Technology Park,  
Song Shan Lake Hi tech Development Zone, Dongguan, 523808, China  
Tel: +86 769 33871725  
Fax: +86 769 33871725  
Website: [www.ul.com](http://www.ul.com)**

Revision History

<u>Rev.</u>	<u>Issue Date</u>	<u>Revisions</u>	<u>Revised By</u>
--	11/24/2017	Initial Issue	

Summary of Test Results			
Clause	Test Items	FCC/IC Rules	Test Results
1	6db DTS Bandwidth and 99% Bandwidth	FCC 15.247 (a) (2) RSS-247 Clause 5.2 (a) RSS-Gen Clause 6.6	PASS
2	Peak Conducted Power	FCC 15.247 (b) (3) RSS-247 Clause 5.4 (e)	PASS
3	Power Spectral Density	FCC 15.247 (e) RSS-247 Clause 5.2 (b)	PASS
4	Conducted Band edge And Spurious emission	FCC 15.247 (d) RSS-247 Clause 5.5	PASS
5	Radiated Band edges and Spurious emission	FCC 15.247 (d) FCC 15.209 FCC 15.205 RSS-247 Clause 5.5 RSS-GEN Clause 8.9 RSS-GEN Clause 8.10	PASS
6	Conducted Emission Test For AC Power Port	FCC 15.207 RSS-GEN Clause 8.8	PASS
7	Antenna Requirement	FCC 15.203 RSS-GEN Clause 8.3	PASS

## TABLE OF CONTENTS

<b>1. ATTESTATION OF TEST RESULTS .....</b>	<b>6</b>
<b>2. TEST METHODOLOGY .....</b>	<b>7</b>
<b>3. FACILITIES AND ACCREDITATION .....</b>	<b>7</b>
<b>4. CALIBRATION AND UNCERTAINTY .....</b>	<b>8</b>
4.1. <i>MEASURING INSTRUMENT CALIBRATION .....</i>	<i>8</i>
4.2. <i>MEASUREMENT UNCERTAINTY.....</i>	<i>8</i>
<b>5. EQUIPMENT UNDER TEST .....</b>	<b>9</b>
5.1. <i>DESCRIPTION OF EUT .....</i>	<i>9</i>
5.2. <i>MAXIMUM OUTPUT POWER.....</i>	<i>9</i>
5.3. <i>CHANNEL LIST.....</i>	<i>9</i>
5.4. <i>TEST CHANNEL CONFIGURATION.....</i>	<i>10</i>
5.5. <i>THE WORSE CASE POWER SETTING PARAMETER.....</i>	<i>10</i>
5.6. <i>DESCRIPTION OF AVAILABLE ANTENNAS .....</i>	<i>10</i>
5.7. <i>WORST-CASE CONFIGURATIONS.....</i>	<i>10</i>
5.8. <i>TEST ENVIRONMENT .....</i>	<i>10</i>
5.9. <i>DESCRIPTION OF TEST SETUP.....</i>	<i>11</i>
5.10. <i>MEASURING INSTRUMENT AND SOFTWARE USED .....</i>	<i>12</i>
<b>6. MEASUREMENT METHODS .....</b>	<b>13</b>
<b>7. ANTENNA PORT TEST RESULTS .....</b>	<b>14</b>
7.1. <i>ON TIME AND DUTY CYCLE.....</i>	<i>14</i>
7.2. <i>6 dB DTS BANDWIDTH AND 99% BANDWIDTH.....</i>	<i>15</i>
7.3. <i>PEAK CONDUCTED OUTPUT POWER.....</i>	<i>20</i>
7.4. <i>POWER SPECTRAL DENSITY.....</i>	<i>23</i>
7.5. <i>CONDUCTED BANDEDGE AND SPURIOUS EMISSIONS.....</i>	<i>26</i>
<b>8. RADIATED TEST RESULTS.....</b>	<b>30</b>
8.1. <i>RESTRICTED BANDEDGE.....</i>	<i>35</i>
8.2. <i>SPURIOUS EMISSIONS (1~18GHz).....</i>	<i>39</i>
8.3. <i>SPURIOUS EMISSIONS 18G ~ 26GHz.....</i>	<i>45</i>
8.4. <i>SPURIOUS EMISSIONS 30M ~ 1 GHz .....</i>	<i>47</i>
8.5. <i>SPURIOUS EMISSIONS BELOW 30M.....</i>	<i>49</i>
<b>9. AC POWER LINE CONDUCTED EMISSIONS.....</b>	<b>53</b>

**10. ANTENNA REQUIREMENTS .....56**

# 1. ATTESTATION OF TEST RESULTS

## Applicant Information

Company Name: Hui Zhou Gaoshengda Technology Co.,LTD  
Address: HuaXing RD,NO 2,ZhongKai High Technology Development Area,Huizhou,Guangdong, China

## Manufacturer Information

Company Name: Hui Zhou Gaoshengda Technology Co.,LTD  
Address: HuaXing RD,NO 2,ZhongKai High Technology Development Area,Huizhou,Guangdong, China

## EUT Description

Product Name: WIFI+BT MODULE  
Brand Name: GSD  
Model Name: WCT0LR2201J  
Sample ID: 1220986  
Sample Status: Good  
Sample Received date: October 20, 2017  
Date Tested: October 23~November 23, 2017

APPLICABLE STANDARDS	
STANDARD	TEST RESULTS
CFR 47 Part 15 Subpart C	PASS
ISED RSS-247 Issue 2	PASS
ISED RSS-GEN Issue 4	PASS

Tested By:

Checked By:

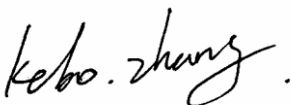

---

Kebo Zhang  
Engineer  
Approved By:

---

Shawn Wen  
Laboratory Leader



---

Stephen Guo  
Laboratory Manager

## 2. TEST METHODOLOGY

The tests documented in this report were performed in accordance with KDB414788 D01 Radiated Test Site v01, ANSI C63.10-2013, KDB558074 D01 DTS Meas Guidance v04, FCC CFR 47 Part 2, FCC CFR 47 Part 15, RSS-GEN Issue 4, and RSS-247 Issue 2.

## 3. FACILITIES AND ACCREDITATION

Test Location	UL Verification Services (Guangzhou) Co., Ltd. Song Shan Lake Branch.
Address	Building 10, Innovation Technology Park, Song Shan Lake Hi tech Development Zone, Dongguan, 523808, China
Accreditation Certificate	UL Verification Services (Guangzhou) Co., Ltd. Song Shan Lake Branch. EMC Laboratory has been accredited by A2LA for technical competence in the field of electrical testing, and proved to be in compliance with ISO/IEC 17025: 2005 General Requirements for the Competence of Testing and Calibration Laboratories and any additional program requirements in the identified field of testing. The Certificate Registration Number is 4102.01. UL Verification Services (Guangzhou) Co., Ltd. Song Shan Lake Branch. EMC Laboratory has been registered and fully described in a report filed with the FCC (Federal Communications Commission). The Designation Number is CN1187. UL Verification Services (Guangzhou) Co., Ltd. Song Shan Lake Branch. EMC Laboratory has been registered and fully described in a report filed with Industry Canada. The Company Number is 21320.

Note: The test anechoic chamber in UL Verification Services (Guangzhou) Co., Ltd. Song Shan Lake Branch had been calibrated and compared to the open field sites.

## 4. CALIBRATION AND UNCERTAINTY

### 4.1. MEASURING INSTRUMENT CALIBRATION

The measuring equipment utilized to perform the tests documented in this report has been calibrated in accordance with the manufacturer's recommendations, and is traceable to recognize national standards.

### 4.2. MEASUREMENT UNCERTAINTY

Where relevant, the following measurement uncertainty levels have been estimated for tests performed on the apparatus:

Test Item	Uncertainty
Uncertainty for Conduction emission test	2.90dB
Uncertainty for Radiation Emission test(include Fundamental emission) (9KHz-30MHz)	2.2dB
Uncertainty for Radiation Emission test(include Fundamental emission) (30MHz-1GHz)	4.52dB
Uncertainty for Radiation Emission test (1GHz to 26GHz)( include Fundamental emission)	5.04dB(1-6GHz)
	5.30dB (6GHz-18Gz)
	5.23dB (18GHz-26Gz)
Note: This uncertainty represents an expanded uncertainty expressed at approximately the 95% confidence level using a coverage factor of k=2.	



## 5. EQUIPMENT UNDER TEST

### 5.1. DESCRIPTION OF EUT

Equipment	WIFI+BT MODULE		
Model Name	WCT0LR2201J		
Product Description	Operation Frequency	2402 MHz ~ 2480 MHz	
	Modulation Type	Data Rate	
	GFSK	1Mbps	
Power Supply	AC120V/60Hz		
Bluetooth Version	BT 4.1LE		
Hardware Version	V1.0		
Software Version	V1.2		

### 5.2. MAXIMUM OUTPUT POWER

Bluetooth Mode	Frequency (MHz)	Channel Number	Max Output Power (dBm)	EIRP (dBm)
BLE	2402-2480	0-39[40]	5.087	8.327

### 5.3. CHANNEL LIST

Channel	Frequency (MHz)	Channel	Frequency (MHz)	Channel	Frequency (MHz)	Channel	Frequency (MHz)
0	2402	11	2424	22	2446	33	2468
1	2404	12	2426	23	2448	34	2470
2	2406	13	2428	24	2450	35	2472
3	2408	14	2430	25	2452	36	2474
4	2410	15	2432	26	2454	37	2476
5	2412	16	2434	27	2456	38	2478
6	2414	17	2436	28	2458	39	2480
7	2416	18	2438	29	2460		
8	2418	19	2440	30	2462		
9	2420	20	2442	31	2464		
10	2422	21	2444	32	2468		

### 5.4. TEST CHANNEL CONFIGURATION

Test Mode	Test Channel	Frequency
GFSK	CH 0, CH 19, CH 39	2402MHz, 2440MHz, 2480MHz

### 5.5. THE WORSE CASE POWER SETTING PARAMETER

The Worst Case Power Setting Parameter under 2400 ~ 2483.5MHz Band				
Test Software		RELBTAPP		
Modulation Type	Transmit Antenna Number	Test Channel		
		CH 00	CH 19	CH 39
GFSK	1	6	6	6

### 5.6. DESCRIPTION OF AVAILABLE ANTENNAS

Ant.	Frequency (MHz)	Antenna Type	Antenna Gain (dBi)
2	2402-2480	External Antenna	3.24

Note: There are two antenna in the EUT, only antenna 2 support BT mode.

Test Mode	Transmit and Receive Mode	Description
GFSK	1TX, 1RX	Chain 1 can be used as transmitting/receiving antenna.

### 5.7. WORST-CASE CONFIGURATIONS

Bluetooth Mode	Modulation Technology	Modulation Type	Data Rate (Mbps)
BLE	DTS	GFSK	1Mbit/s

### 5.8. TEST ENVIRONMENT

Environment Parameter	Selected Values During Tests	
Relative Humidity	55 ~ 65%	
Atmospheric Pressure:	1025Pa	
Temperature	TN	23 ~ 28°C
Voltage :	VL	N/A
	VN	AC 120V 60Hz
	VH	N/A

Note: VL= Lower Extreme Test Voltage  
 VN= Nominal Voltage  
 VH= Upper Extreme Test Voltage  
 TN= Normal Temperature

## 5.9. DESCRIPTION OF TEST SETUP

### SUPPORT EQUIPMENT

Item	Equipment	Brand Name	Model Name	P/N
1	PC	Dell	Vostro 3902	8KNDDDB2
2	USB TO RS232	N/A	N/A	N/A

### I/O CABLES

Cable No	Port	Connector Type	Cable Type	Cable Length(m)	Remarks
1	N/A	N/A	N/A	N/A	N/A

### ACCESSORY

Item	Accessory	Brand Name	Model Name	Description
1	N/A	N/A	N/A	N/A

### TEST SETUP

The EUT can work in an engineer mode with a software through a PC.

### SETUP DIAGRAM FOR TEST

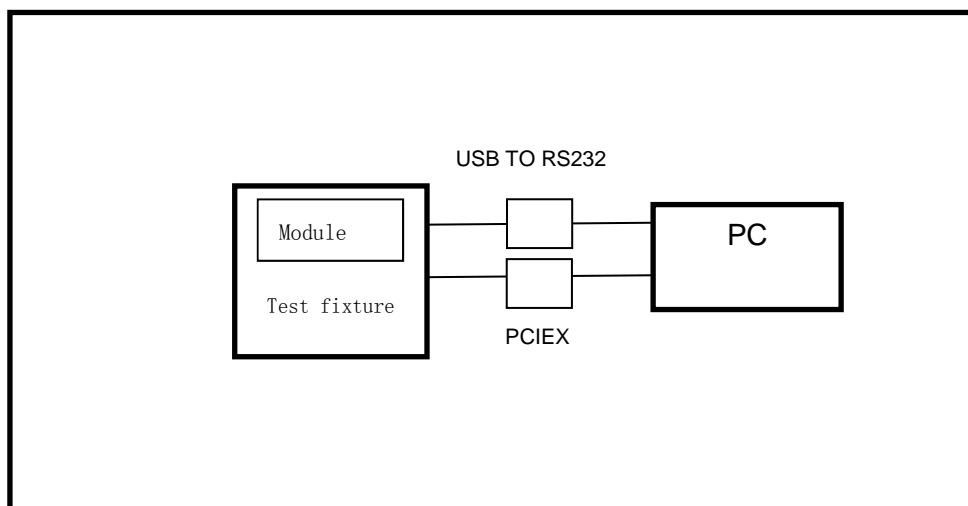

### 5.10. MEASURING INSTRUMENT AND SOFTWARE USED

Conducted Emissions						
Used	Equipment	Manufacturer	Model No.	Serial No.	Last Cal.	Next Cal.
<input checked="" type="checkbox"/>	EMI Test Receiver	R&S	ESR3	101961	Dec.20, 2016	Dec.19, 2017
<input checked="" type="checkbox"/>	Two-Line V-Network	R&S	ENV216	101983	Dec.20, 2016	Dec.19, 2017
<input checked="" type="checkbox"/>	Artificial Mains Networks	Schwarzbeck	NSLK 8126	8126465	Feb.10, 2017	Feb.10, 2018
Software						
Used	Description	Manufacturer	Name	Version		
<input checked="" type="checkbox"/>	Test Software for Conducted disturbance	UL	Antenna port	Ver. 7.2		
Radiated Emissions						
Used	Equipment	Manufacturer	Model No.	Serial No.	Last Cal.	Next Cal.
<input checked="" type="checkbox"/>	MXE EMI Receiver	KESIGHT	N9038A	MY564000 36	Feb. 24, 2017	Feb. 24, 2018
<input checked="" type="checkbox"/>	Hybrid Log Periodic Antenna	TDK	HLP-3003C	130960	Jan.09, 2016	Jan.09, 2019
<input checked="" type="checkbox"/>	Preamplifier	HP	8447D	2944A0909 9	Feb. 13, 2017	Feb. 13, 2018
<input checked="" type="checkbox"/>	EMI Measurement Receiver	R&S	ESR26	101377	Dec. 20, 2016	Dec. 20, 2017
<input checked="" type="checkbox"/>	Horn Antenna	TDK	HRN-0118	130939	Jan. 09, 2016	Jan. 09, 2019
<input checked="" type="checkbox"/>	High Gain Horn Antenna	Schwarzbeck	BBHA-9170	691	Jan.06, 2016	Jan.06, 2019
<input checked="" type="checkbox"/>	Preamplifier	TDK	PA-02-0118	TRS-305- 00066	Jan. 14, 2017	Jan. 14, 2018
<input checked="" type="checkbox"/>	Preamplifier	TDK	PA-02-2	TRS-307- 00003	Dec. 20, 2016	Dec. 20, 2017
<input checked="" type="checkbox"/>	Loop antenna	Schwarzbeck	1519B	00008	Mar. 26, 2016	Mar. 26, 2019
<input checked="" type="checkbox"/>	Band Reject Filter	Wainwright	WRCJV8- 2350-2400- 2483.5-2533.5- 40SS	4	Dec. 20, 2016	Dec. 20, 2017
Software						
Used	Description	Manufacturer	Name	Version		
<input checked="" type="checkbox"/>	Test Software for Radiated disturbance	Farad	EZ-EMC	Ver. UL-3A1		
Other instruments						
Used	Equipment	Manufacturer	Model No.	Serial No.	Last Cal.	Next Cal.
<input checked="" type="checkbox"/>	Spectrum Analyzer	Keysight	N9030A	MY554105 12	Dec. 20, 2016	Dec. 20, 2017
<input checked="" type="checkbox"/>	Power Meter	Keysight	N9031A	MY554160 24	Feb. 13, 2017	Feb. 13, 2018
<input checked="" type="checkbox"/>	Power Sensor	Keysight	N9323A	MY554400 13	Feb. 13, 2017	Feb. 13, 2018

## 6. MEASUREMENT METHODS

No.	Test Item	KDB Name	Section
1	6 dB Bandwidth	KDB 558074 D01 DTS Meas Guidance v04	8.0
2	Peak Output Power	KDB 558074 D01 DTS Meas Guidance v04	9.1.1
3	Power Spectral Density	KDB 558074 D01 DTS Meas Guidance v04	10.2
4	Out-of-band emissions in non-restricted bands	KDB 558074 D01 DTS Meas Guidance v04	11.0
5	Out-of-band emissions in restricted bands	KDB 558074 D01 DTS Meas Guidance v04	12.1
6	Band-edge	KDB 558074 D01 DTS Meas Guidance v04	13.3.2
7	Conducted Emission Test For AC Power Port	ANSI C63.10-2013	7.3

## 7. ANTENNA PORT TEST RESULTS

### 7.1. ON TIME AND DUTY CYCLE

#### LIMITS

None; for reporting purposes only

#### PROCEDURE

KDB 558074 Zero-Span Spectrum Analyzer Method

#### TEST SETUP

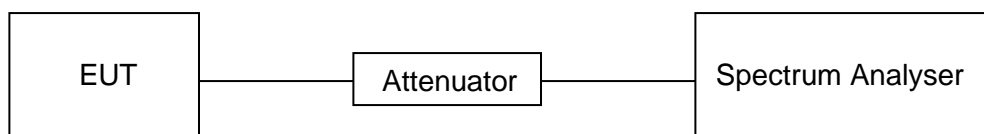

#### RESULTS

Mode	On Time (msec)	Period (msec)	Duty Cycle x (Linear)	Duty Cycle (%)	Duty Cycle Correction Factor (db)	1/T Minimum VBW (KHz)
BLE	133.1	133.1	1	100	0	0.0075

Note: Duty Cycle Correction Factor= $10\log(1/x)$ .  
 Where: x is Duty Cycle(Linear)  
 Where: T is On Time (transmit duration)

#### ON TIME AND DUTY CYCLE MID CH

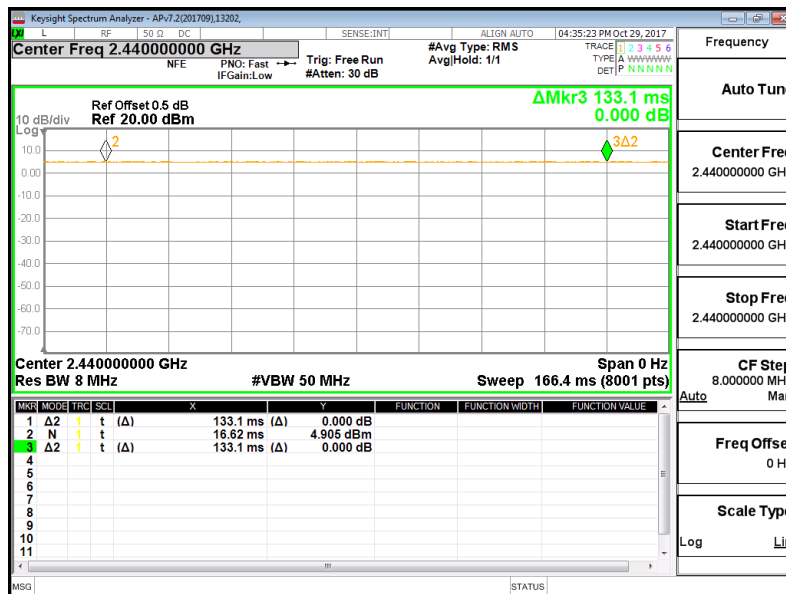

## 7.2. 6 dB DTS BANDWIDTH AND 99% BANDWIDTH

### LIMITS

FCC Part15 (15.247) Subpart C RSS-247 ISSUE 2			
Section	Test Item	Limit	Frequency Range (MHz)
FCC 15.247(a)(2) RSS-247 5.2 (a)	6dB Bandwidth	$\geq 500\text{KHz}$	2400-2483.5
RSS-Gen Clause 6.6	99% Bandwidth	For reporting purposes only.	2400-2483.5

### TEST PROCEDURE

Connect the UUT to the spectrum analyser and use the following settings:

Center Frequency	The center frequency of the channel under test
Detector	Peak
RBW	For 6 dB Bandwidth :100K For 99% Bandwidth :1% to 5% of the occupied bandwidth
VBW	For 6dB Bandwidth : $\geq 3 \times \text{RBW}$ For 99% Bandwidth : approximately $3 \times \text{RBW}$
Trace	Max hold
Sweep	Auto couple

Allow the trace to stabilize and measure the maximum width of the emission that is constrained by the frequencies associated with the two outermost amplitude points (upper and lower frequencies) that are attenuated by 6 dB relative to the maximum level measured in the fundamental emission.

### TEST SETUP

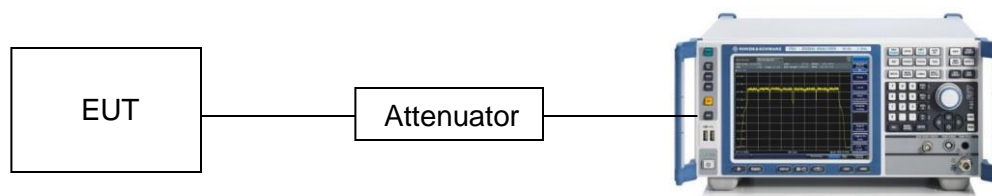

**RESULTS**

Channel	Frequency (MHz)	6dB bandwidth (MHz)	99% bandwidth (MHz)	Limit (kHz)	Result
Low	2402	0.466	0.88503	500	Pass
Middle	2440	0.464	0.87333	500	Pass
High	2480	0.470	0.87147	500	Pass

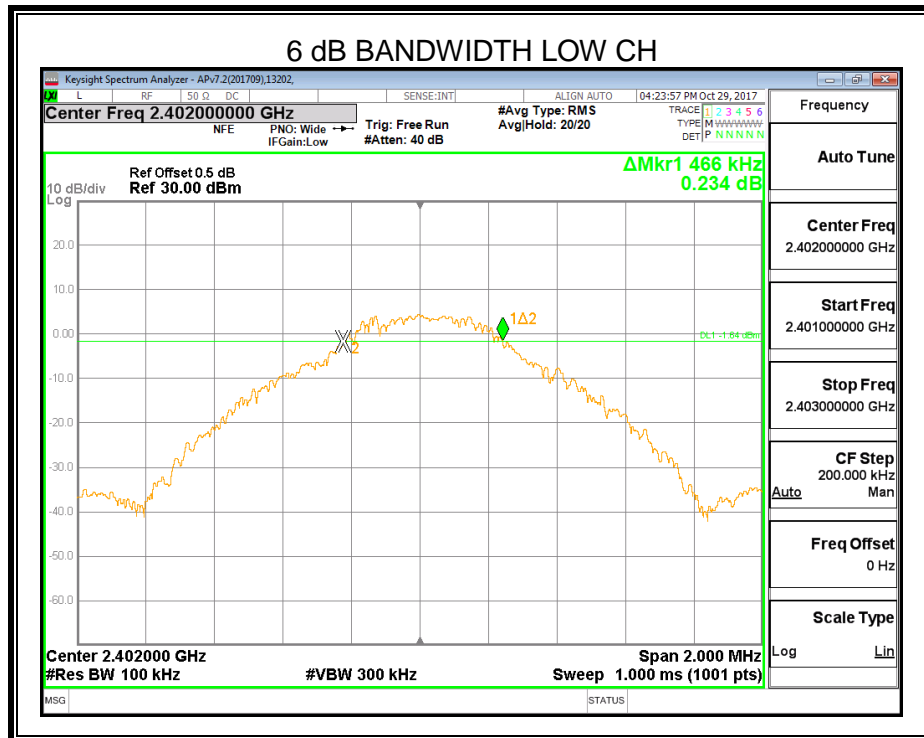



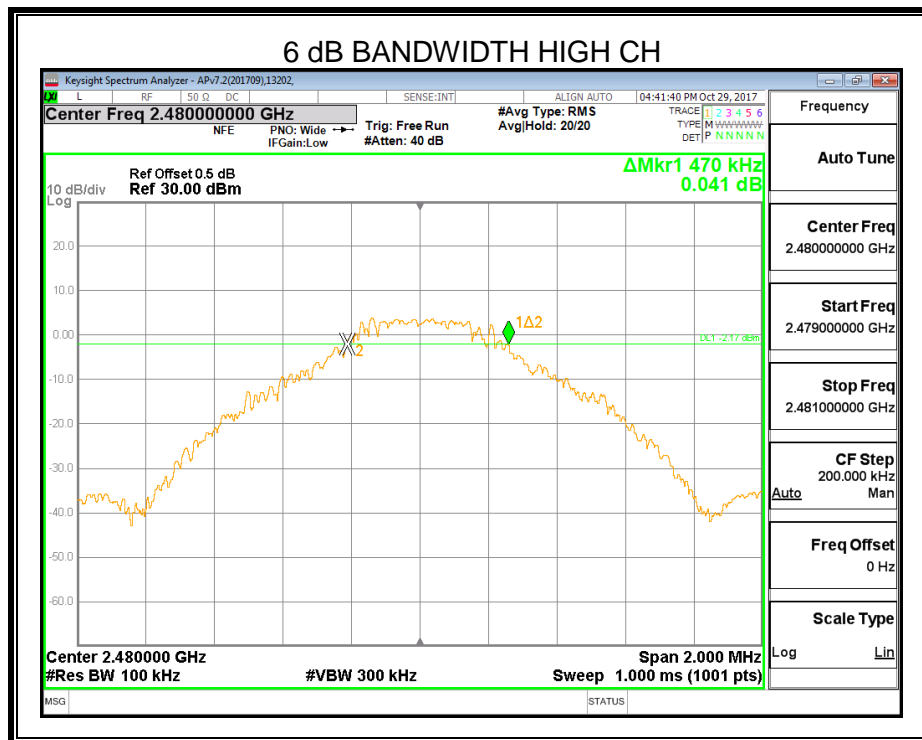
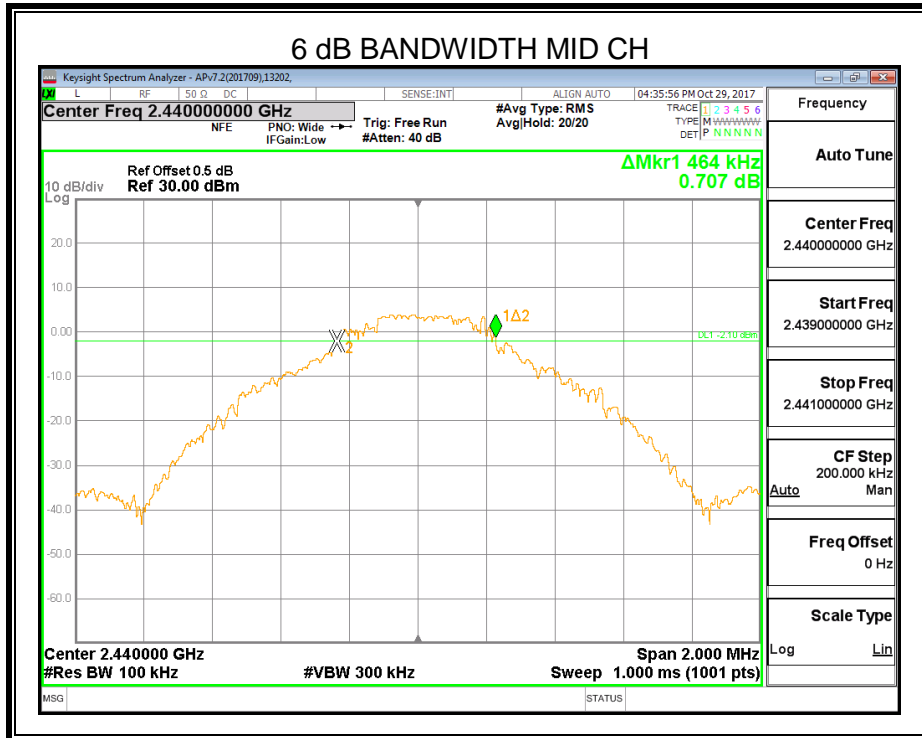

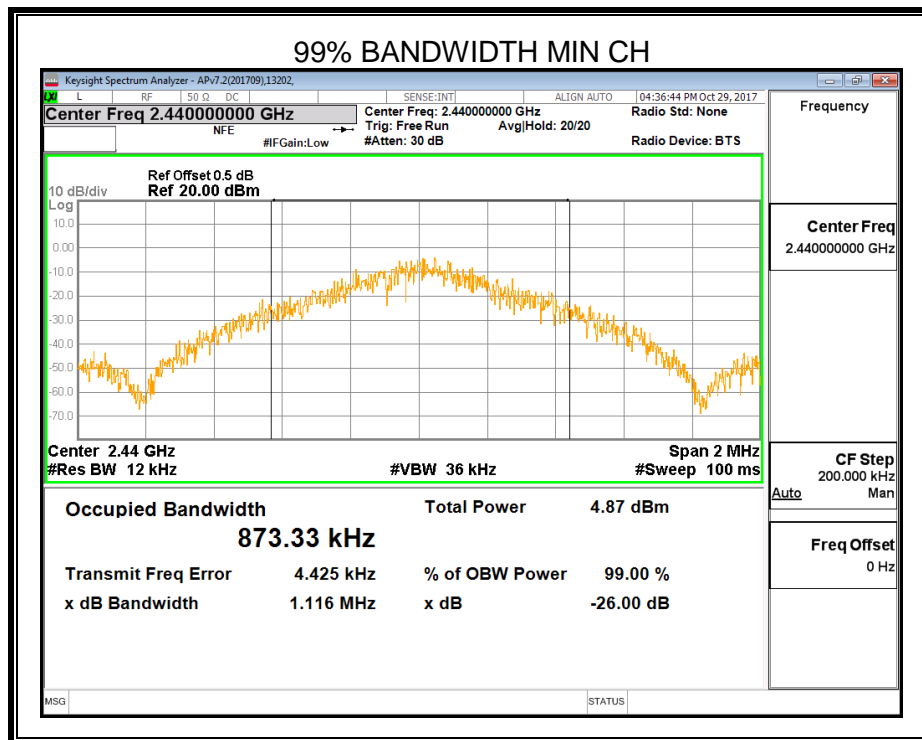
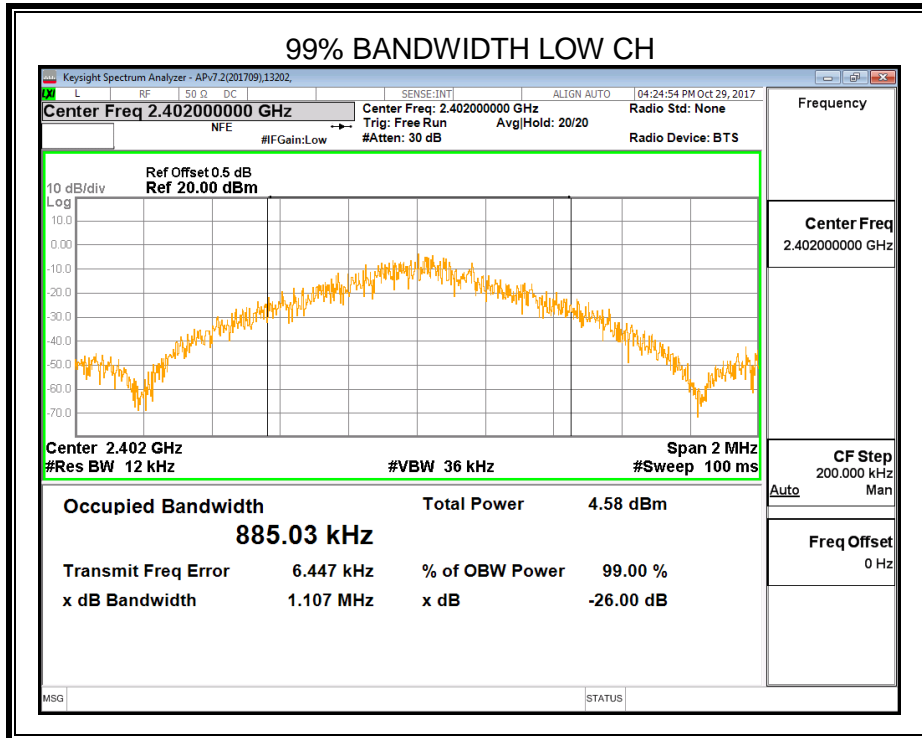

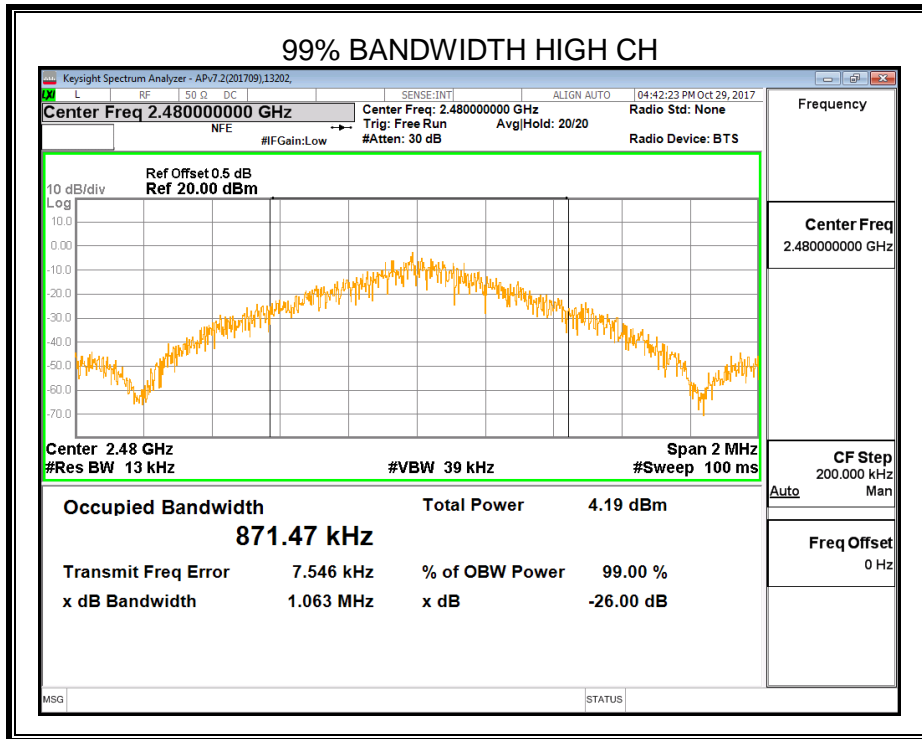

### 7.3. PEAK CONDUCTED OUTPUT POWER

#### LIMITS

FCC Part15 (15.247) Subpart C RSS-247 ISSUE 2			
Section	Test Item	Limit	Frequency Range (MHz)
FCC 15.247(b)(3) RSS-247 5.4 (e)	Peak Output Power	1 watt or 30dBm	2400-2483.5

#### TEST PROCEDURE

Connect the UUT to the spectrum analyser and use the following settings:

Center Frequency	The center frequency of the channel under test
Detector	Peak
RBW	$\geq$ DTS bandwidth(e.g. 1 MHz for BLE)
VBW	$\geq 3 \times$ RBW
Span	$3 \times$ RBW
Trace	Max hold
Sweep time	Auto couple.

Allow trace to fully stabilize and use peak marker function to determine the peak amplitude level.

#### TEST SETUP

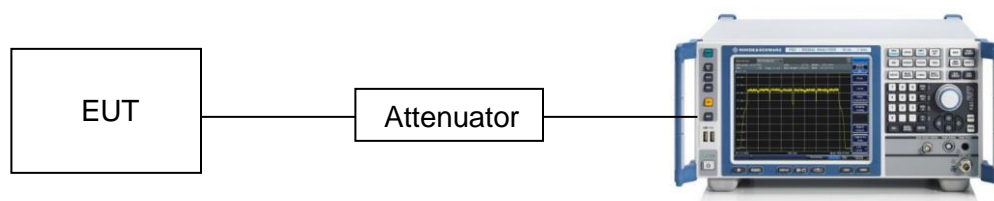

**RESULTS**

Test Channel	Frequency	Maximum Conducted Output Power(PK)	EIRP	LIMIT
	(MHz)	(dBm)	(dBm)	dBm
CH00	2402	5.087	8.327	30
CH19	2440	4.872	8.112	30
CH39	2480	4.495	7.735	30

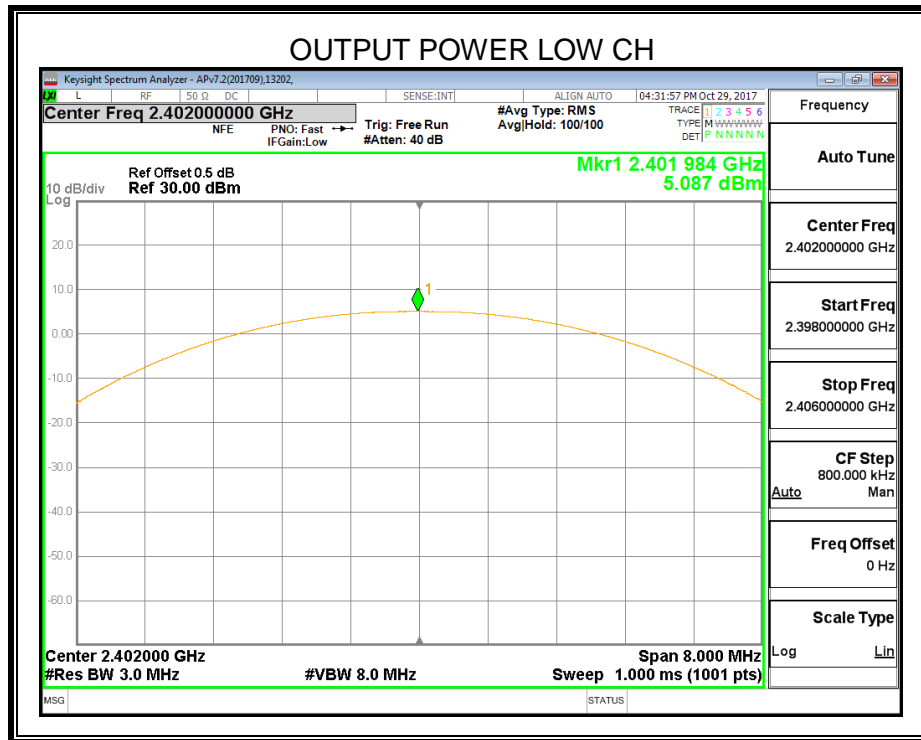

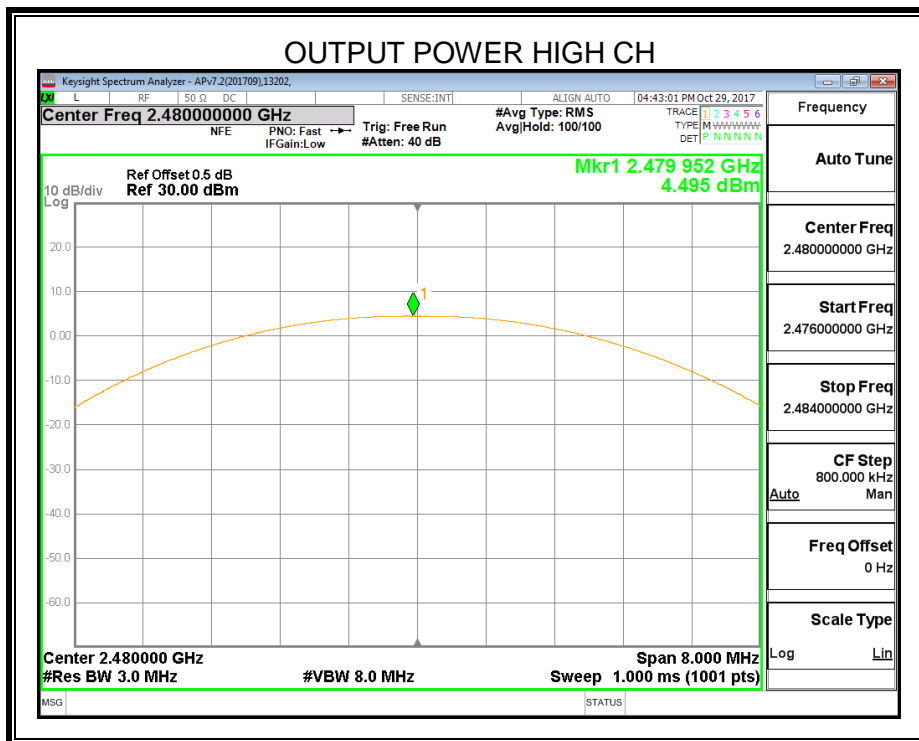
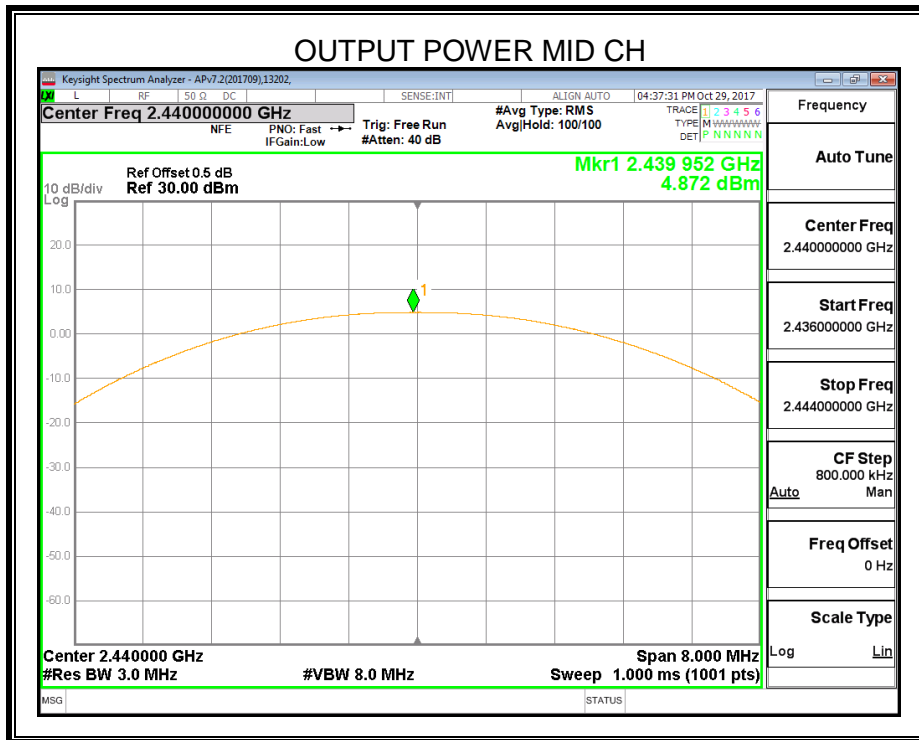

## 7.4. POWER SPECTRAL DENSITY

### LIMITS

FCC Part15 (15.247) Subpart C RSS-247 ISSUE 2			
Section	Test Item	Limit	Frequency Range (MHz)
FCC §15.247 (e) RSS-247 5.2 (b)	Power Spectral Density	8 dBm in any 3 kHz band	2400-2483.5

### TEST PROCEDURE

Connect the UUT to the spectrum analyser and use the following settings:

Center Frequency	The center frequency of the channel under test
Detector	Peak
RBW	$3 \text{ kHz} \leq \text{RBW} \leq 100 \text{ kHz}$
VBW	$\geq 3 \times \text{RBW}$
Span	1.5 x DTS bandwidth
Trace	Max hold
Sweep time	Auto couple.

Allow trace to fully stabilize and use the peak marker function to determine the maximum amplitude level within the RBW.  
 If measured value exceeds limit, reduce RBW (no less than 3 kHz) and repeat.

### TEST SETUP

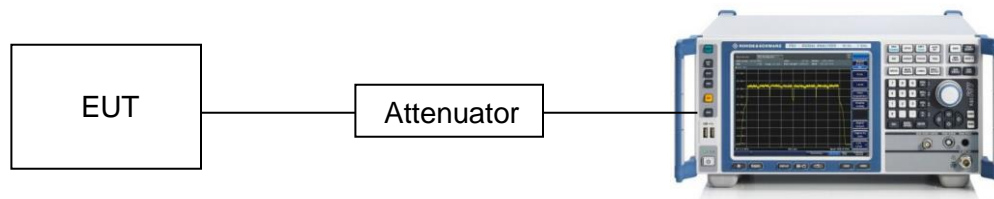

**RESULTS**

Frequency	Power Spectral Density (dBm/3kHz)	Limit (dBm/3kHz)	Result
2402 MHz	-5.193	8	PASS
2440 MHz	-3.841	8	PASS
2480 MHz	-4.647	8	PASS

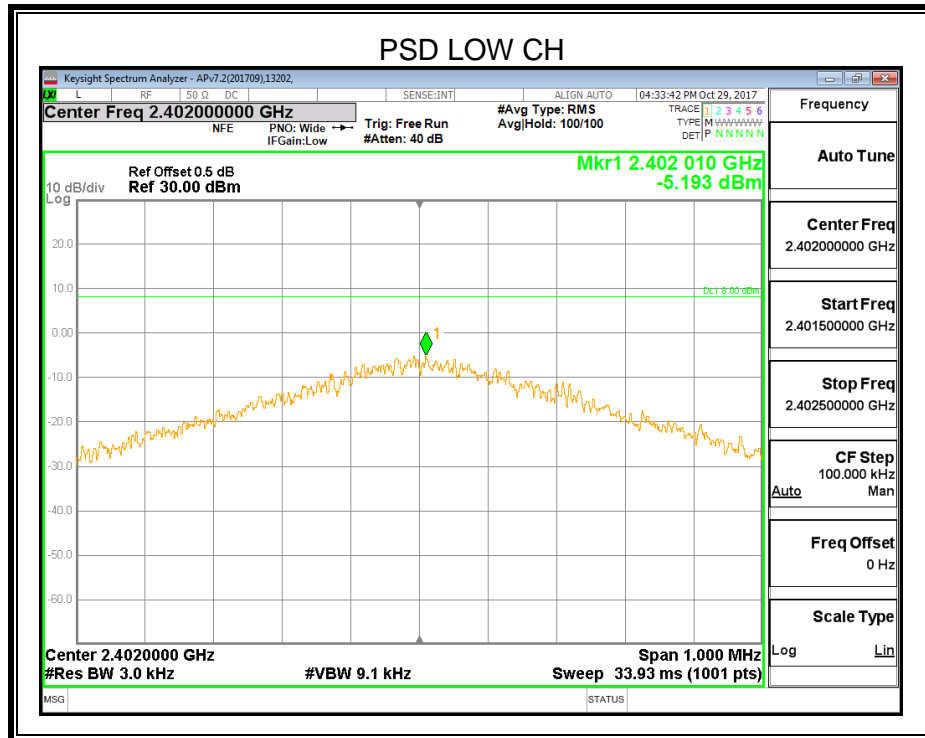



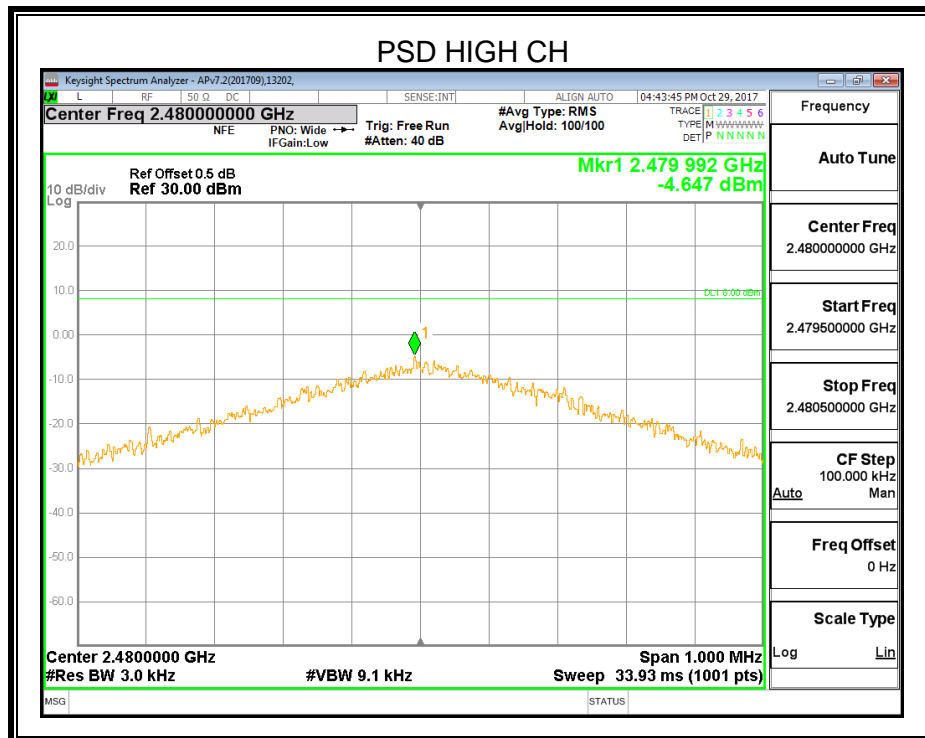
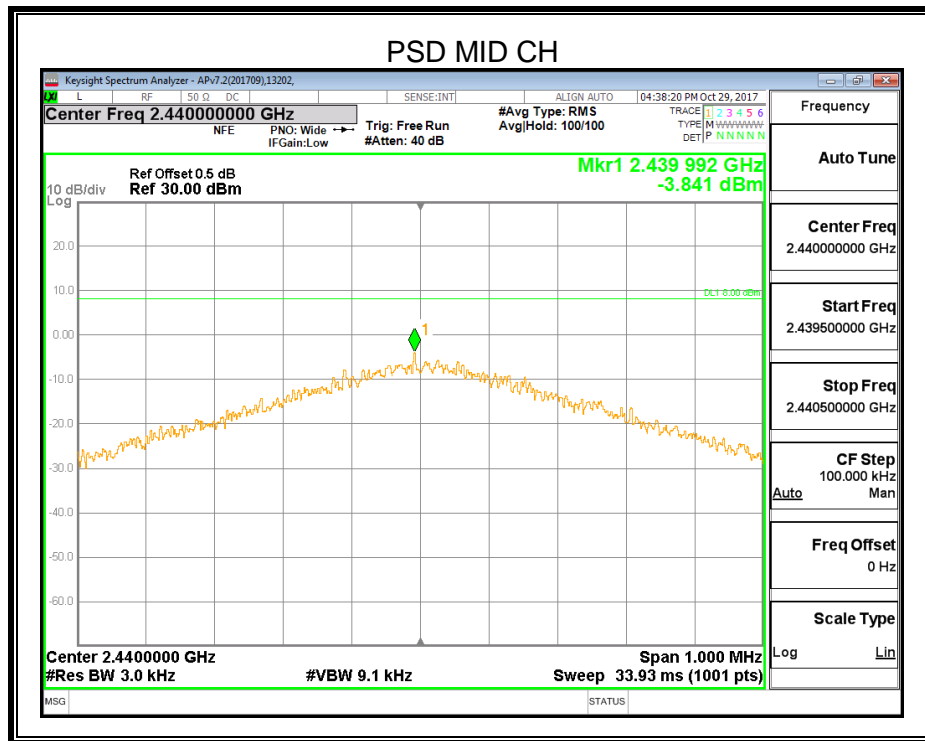

## 7.5. CONDUCTED BANDEGE AND SPURIOUS EMISSIONS

### LIMITS

FCC Part15 (15.247) Subpart C RSS-247 ISSUE 2		
Section	Test Item	Limit
FCC §15.247 (d) RSS-247 5.5	Conducted Bandedge and Spurious Emissions	at least 20 dB below that in the 100 kHz bandwidth within the band that contains the highest level of the desired power

### TEST PROCEDURE

Connect the UUT to the spectrum analyser and use the following settings:

Center Frequency	The center frequency of the channel under test
Detector	Peak
RBW	100K
VBW	$\geq 3 \times \text{RBW}$
Span	1.5 x DTS bandwidth
Trace	Max hold
Sweep time	Auto couple.

Use the peak marker function to determine the maximum PSD level.

Span	Set the center frequency and span to encompass frequency range to be measured
Detector	Peak
RBW	100K
VBW	$\geq 3 \times \text{RBW}$
measurement points	$\geq \text{span}/\text{RBW}$
Trace	Max hold
Sweep time	Auto couple.

Use the peak marker function to determine the maximum amplitude level.

### TEST SETUP

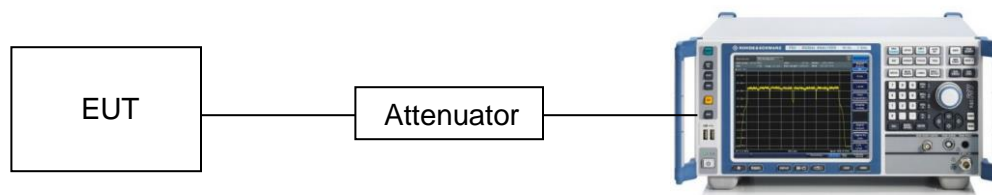

**RESULTS**

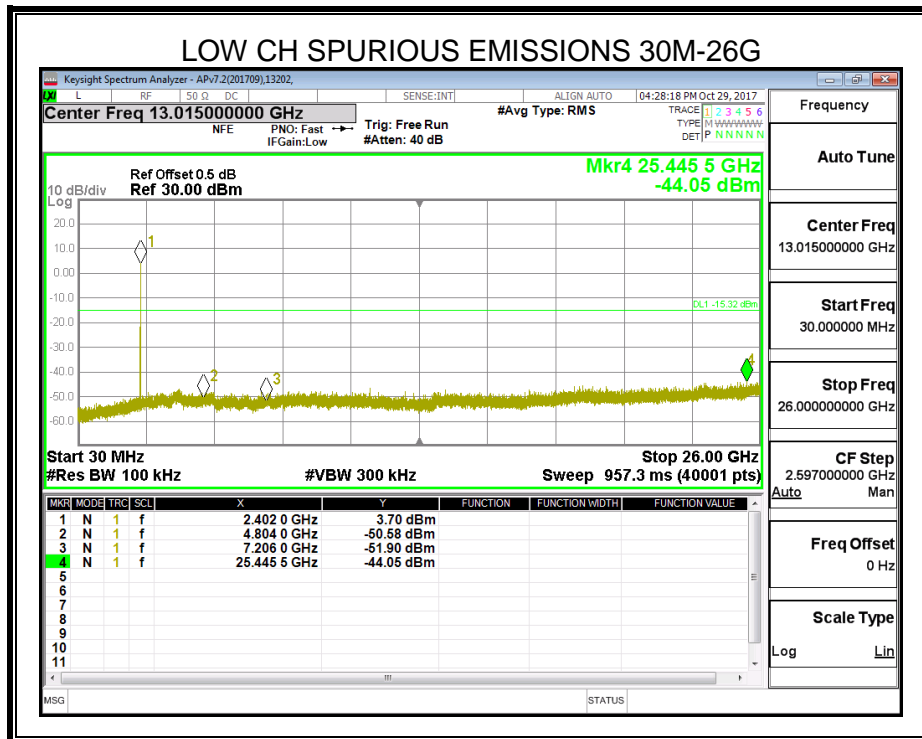
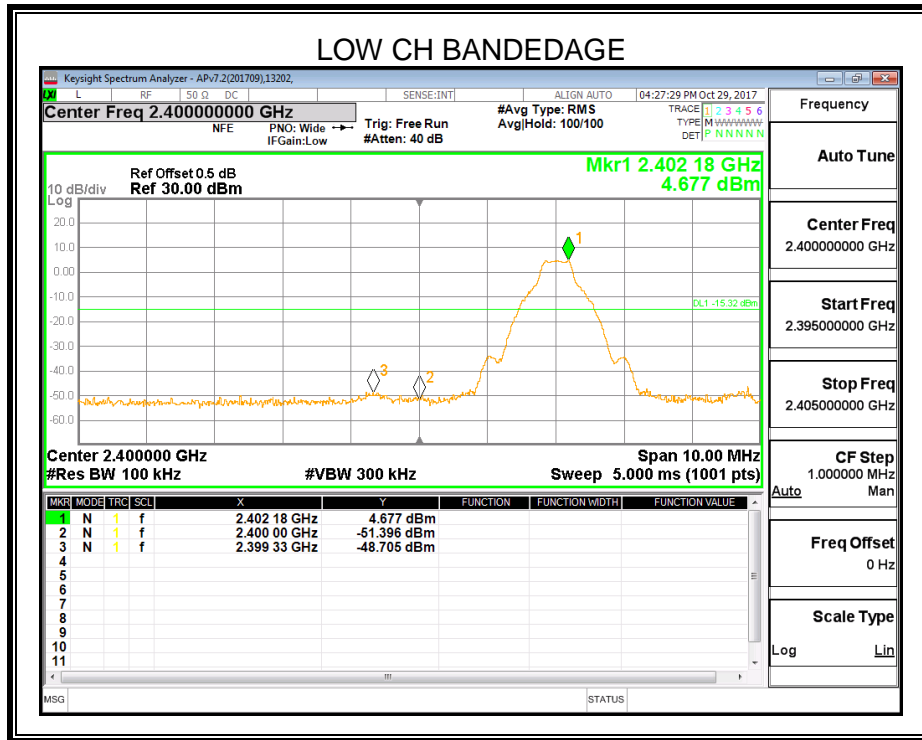

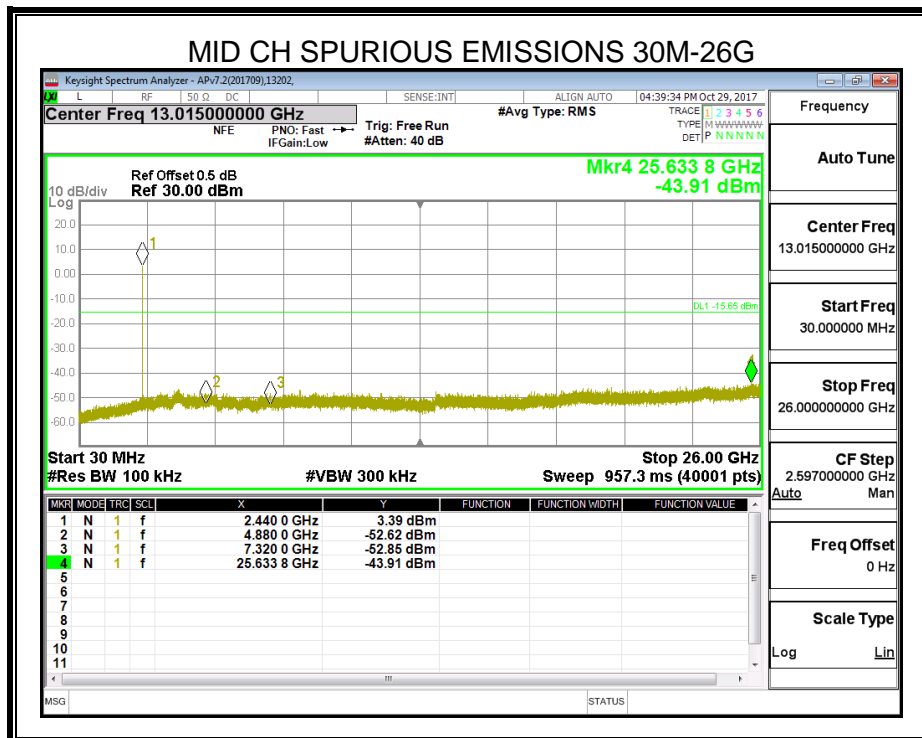
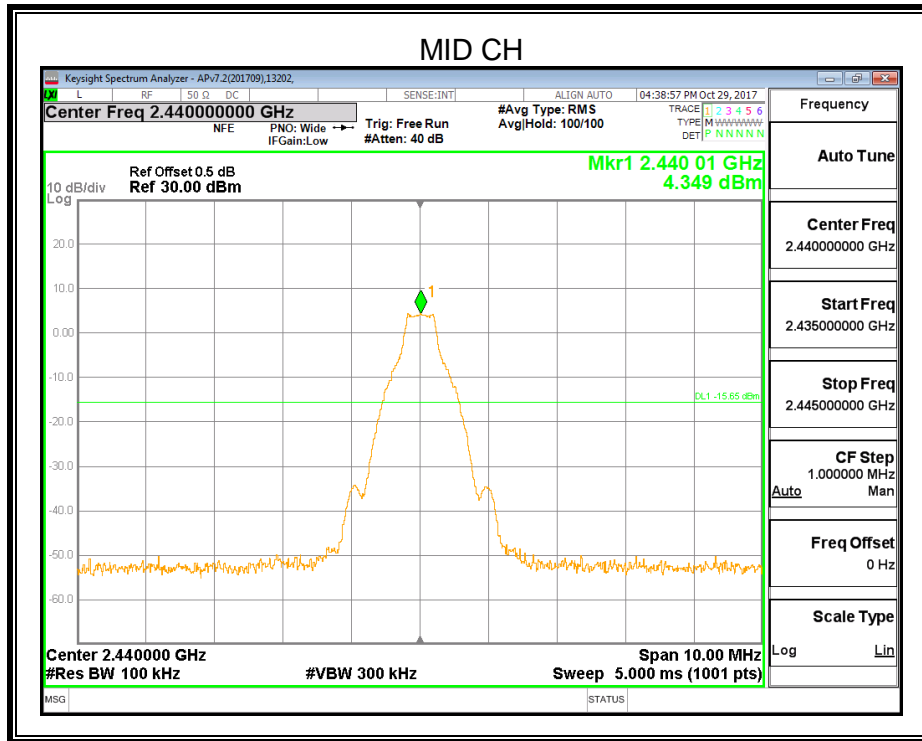

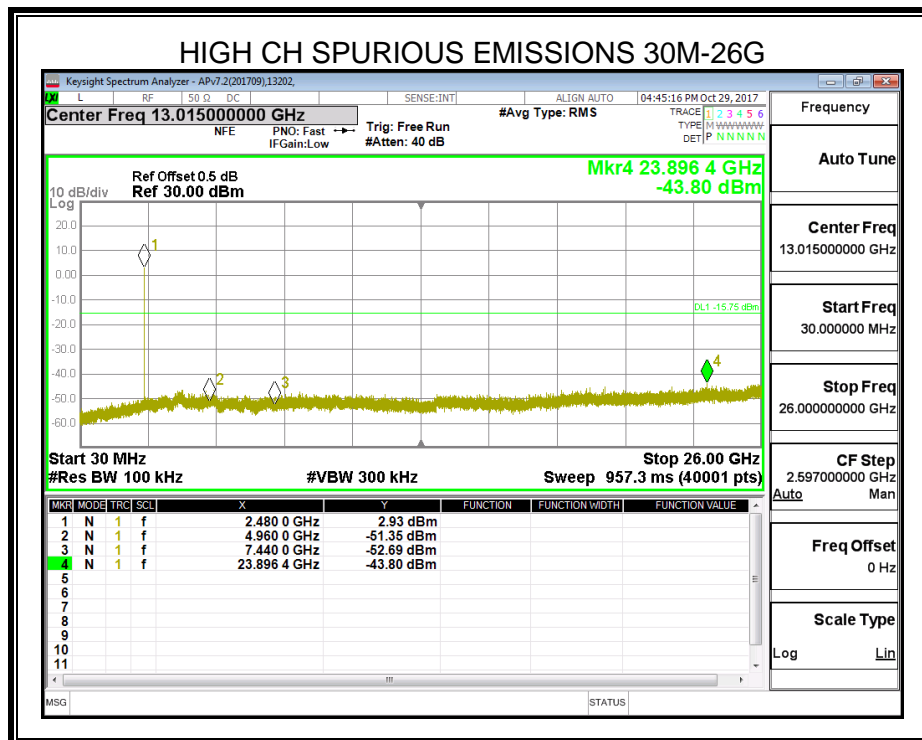
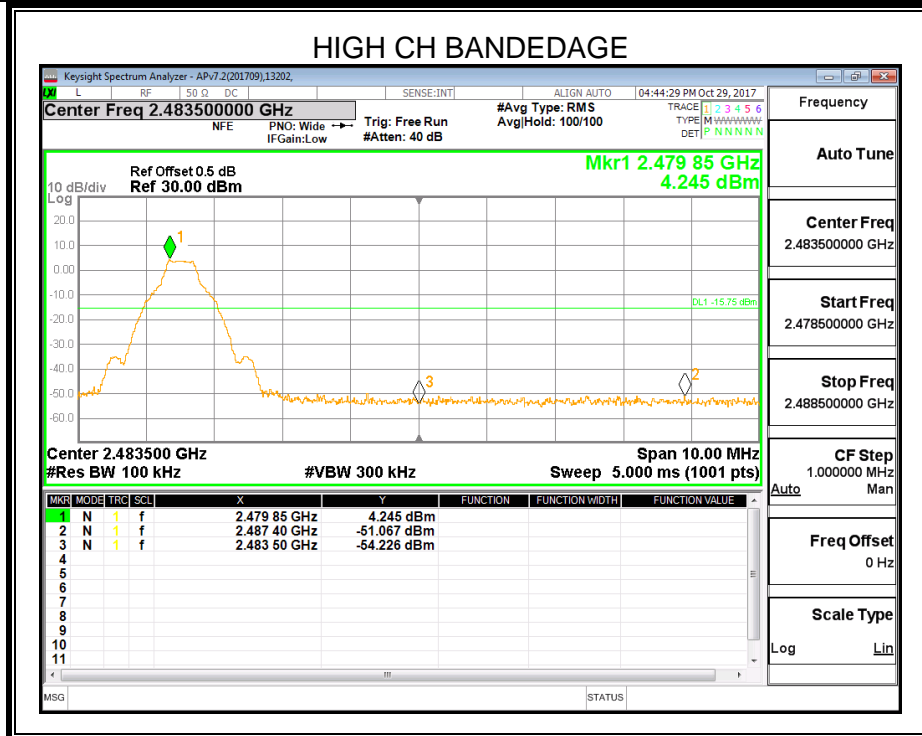

## 8. RADIATED TEST RESULTS

### LIMITS

Please refer to FCC §15.205 and §15.209

Please refer to RSS-GEN Clause 8.9 and Clause 8.10

Radiation Disturbance Test Limit for FCC (Class B)(9KHz-1GHz)

Frequency (MHz)	Field Strength (microvolts/meter)	Measurement Distance (meters)
0.009~0.490	2400/F(KHz)	300
0.490~1.705	24000/F(KHz)	30
1.705~30.0	30	30
30~88	100	3
88~216	150	3
216~960	200	3
960~1000	500	3

Note: 1) At frequencies at or above 30 MHz, measurements may be performed at a distance other than what is specified provided: measurements are not made in the near field except where it can be shown that near field measurements are appropriate due to the characteristics of the device; and it can be demonstrated that the signal levels needed to be measured at the distance employed can be detected by the measurement equipment. Measurements shall not be performed at a distance greater than 30 meters unless it can be further demonstrated that measurements at a distance of 30 meters or less are impractical. When performing measurements at a distance other than that specified, the results shall be extrapolated to the specified distance using an extrapolation factor of 20 dB/decade (inverse linear-distance for field strength measurements; inverse-linear-distance-squared for power density measurements).

(2) At frequencies below 30 MHz, measurements may be performed at a distance closer than that specified in the regulations; however, an attempt should be made to avoid making measurements in the near field. Pending the development of an appropriate measurement procedure for measurements performed below 30 MHz, when performing measurements at a closer distance than specified, the results shall be extrapolated to the specified distance by either making measurements at a minimum of two distances on at least one radial to determine the proper extrapolation factor or by using the square of an inverse linear distance extrapolation factor (40 dB/decade). This paragraph (f) shall not apply to Access BPL devices operating below 30 MHz.

Radiation Disturbance Test Limit for FCC (Above 1G)

Frequency (MHz)	dB(uV/m) (at 3 meters)	
	Peak	Average
Above 1000	74	54

Restricted bands of operation

MHz	MHz	MHz	GHz
0.090-0.110	16.42-16.423	399.9-410	4.5-5.15
<sup>1</sup> 0.495-0.505	16.69475-16.69525	608-614	5.35-5.46
2.1735-2.1905	16.80425-16.80475	960-1240	7.25-7.75
4.125-4.128	25.5-25.67	1300-1427	8.025-8.5
4.17725-4.17775	37.5-38.25	1435-1626.5	9.0-9.2
4.20725-4.20775	73-74.6	1645.5-1646.5	9.3-9.5
6.215-6.218	74.8-75.2	1660-1710	10.6-12.7
6.26775-6.26825	108-121.94	1718.8-1722.2	13.25-13.4
6.31175-6.31225	123-138	2200-2300	14.47-14.5
8.291-8.294	149.9-150.05	2310-2390	15.35-16.2
8.362-8.366	156.52475-156.52525	2483.5-2500	17.7-21.4
8.37625-8.38675	156.7-156.9	2690-2900	22.01-23.12
8.41425-8.41475	162.0125-167.17	3260-3267	23.6-24.0
12.29-12.293	167.72-173.2	3332-3339	31.2-31.8
12.51975-12.52025	240-285	3345.8-3358	36.43-36.5
12.57675-12.57725	322-335.4	3600-4400	( <sup>2</sup> )
13.36-13.41			

Note: <sup>1</sup>Until February 1, 1999, this restricted band shall be 0.490-0.510 MHz.

<sup>2</sup>Above 38.6c

### TEST SETUP AND PROCEDURE

Below 30MHz

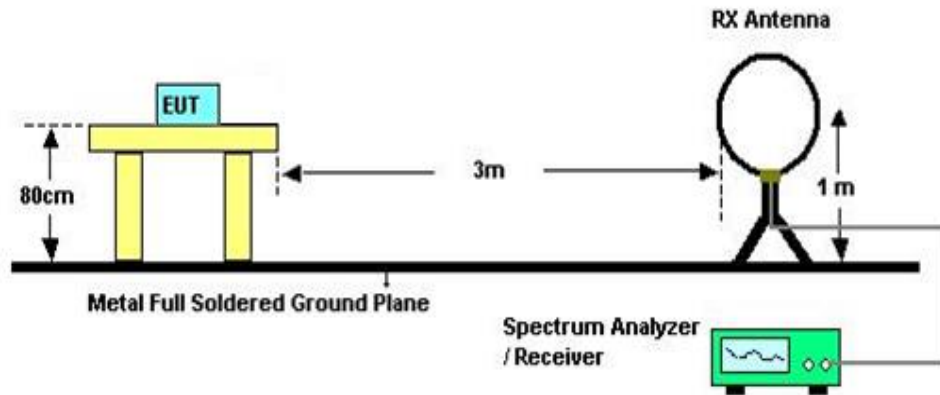

The setting of the spectrum analyser

RBW	200Hz (From 9kHz to 0.15MHz)/ 9KHz (From 0.15MHz to 30MHz)
VBW	200Hz (From 9kHz to 0.15MHz)/ 9KHz (From 0.15MHz to 30MHz)
Sweep	Auto
Trace	Max hold

1. The testing follows the guidelines in ANSI C63.10-2013
2. The EUT was arranged to its worst case and then turntable (from 0 degree to 360 degrees) to find the maximum reading. A pre-amp and a high pass filter are used for the test in order to get better signal level. Both horizontal and vertical polarizations of the antenna are set to make the measurement.
3. The EUT was placed on a turntable with 80cm above ground.
4. The EUT was set 3 meters from the interference receiving antenna, which was mounted on the top of a variable height antenna tower.
5. The radiated emission limits are based on measurements employing a CISPR quasi-peak detector except for the frequency bands 9-90 kHz, 110-490 kHz and above 1000 MHz. Radiated emission limits in these three bands are based on measurements employing an average detector.
6. For measurement below 1GHz, the initial step in collecting conducted emission data is a spectrum analyzer peak detector mode pre-scanning the measurement frequency range. Significant peaks are then marked and then Quasi Peak and average detector mode re-measured. If the emission level of the EUT measured by the peak detector is 3 dB lower than the applicable limit, the peak emission level will be reported. Otherwise, the emission measurement will be repeated using the quasi-peak and average detector and reported.
7. For the actual test configuration, please refer to the related item in this test report (Photographs of the Test Configuration)



Below 1G and above 30MHz

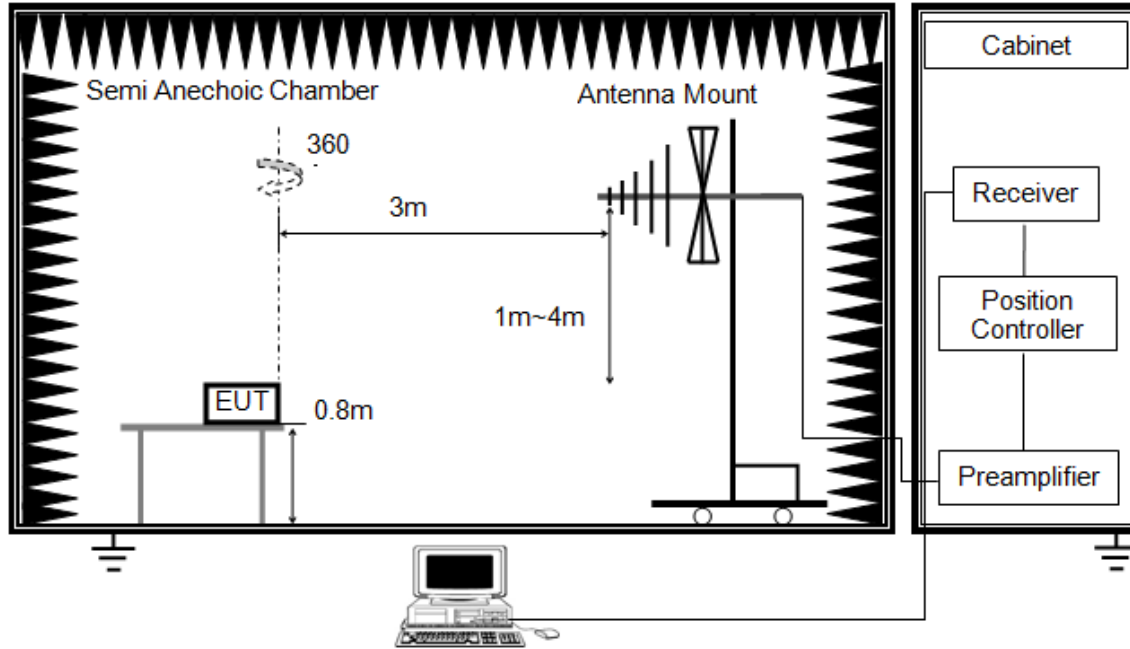

The setting of the spectrum analyser

RBW	120K
VBW	300K
Sweep	Auto
Detector	Peak/QP
Trace	Max hold

1. The testing follows the guidelines in ANSI C63.10-2013.
2. The EUT was arranged to its worst case and then tune the antenna tower (from 1 m to 4 m) and turntable (from 0 degree to 360 degrees) to find the maximum reading. A pre-amp and a high pass filter are used for the test in order to get better signal level. Both horizontal and vertical polarizations of the antenna are set to make the measurement.
3. The EUT was placed on a turntable with 80cm above ground.
4. The EUT was set 3 meters from the interference receiving antenna, which was mounted on the top of a variable height antenna tower.
5. For measurement below 1GHz, the initial step in collecting conducted emission data is a spectrum analyzer peak detector mode pre-scanning the measurement frequency range. Significant peaks are then marked and then Quasi Peak detector mode re-measured. If the emission level of the EUT measured by the peak detector is 3 dB lower than the applicable limit, the peak emission level will be reported. Otherwise, the emission measurement will be repeated using the quasi-peak detector and reported.
6. For the actual test configuration, please refer to the related item in this test report (Photographs of the Test Configuration)

Above 1G

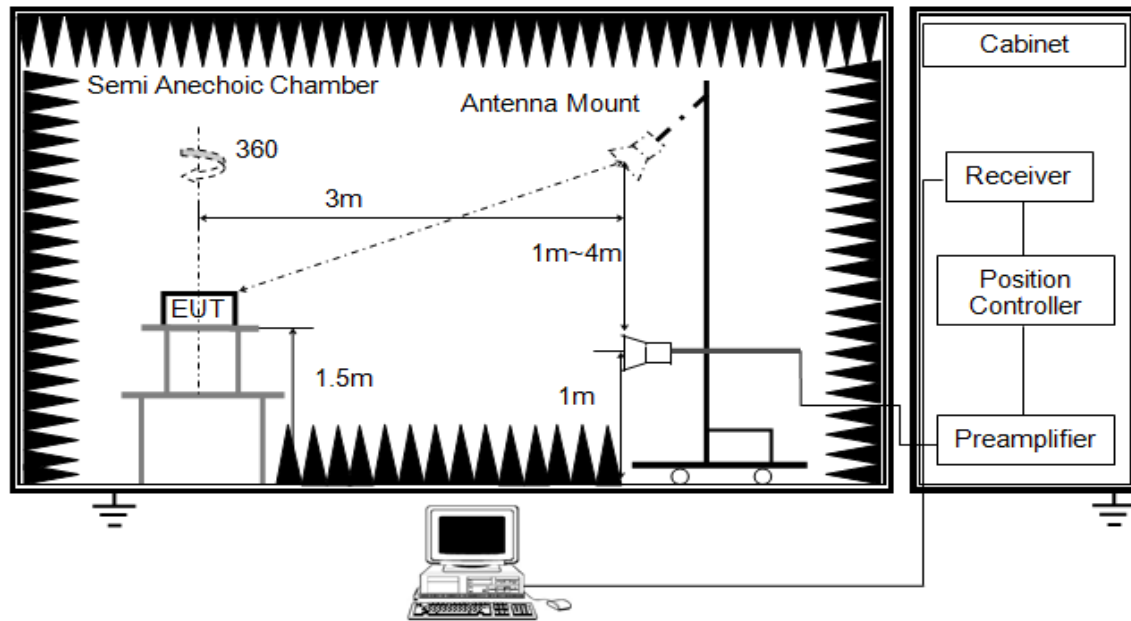

The setting of the spectrum analyser

RBW	1M
VBW	PEAK: 3M AVG: see note 6
Sweep	Auto
Detector	Peak
Trace	Max hold

1. The testing follows the guidelines in ANSI C63.10-2013.
2. The EUT was arranged to its worst case and then tune the antenna tower (1.5 m) and turntable (from 0 degree to 360 degrees) to find the maximum reading. A pre-amp and a high pass filter are used for the test in order to get better signal level. Both horizontal and vertical polarizations of the antenna are set to make the measurement.
3. The EUT was placed on a turntable with 80cm above ground.
4. The EUT was set 3 meters from the interference receiving antenna, which was mounted on the top of a variable height antenna tower.
5. For measurement above 1GHz, the emission measurement will be measured by the peak detector. This peak level, once corrected, must comply with the limit specified in Section 15.209.
6. For measurements above 1 GHz the resolution bandwidth is set to 1 MHz, then the video bandwidth is set to 3 MHz for peak measurements and 1 MHz resolution bandwidth with 1/T video bandwidth with peak detector. For the Duty Cycle and Correction Factor please refer to clause 7.1.ON TIME AND DUTY CYCLE. The EUT is configured to transmit with  $D \geq 98\%$ , then set  $VBW \leq RBW / 100$ , but not less than 10 Hz.
7. For the actual test configuration, please refer to the related Item in this test report (Photographs of the Test Configuration)

X axis, Y axis, Z axis positions:

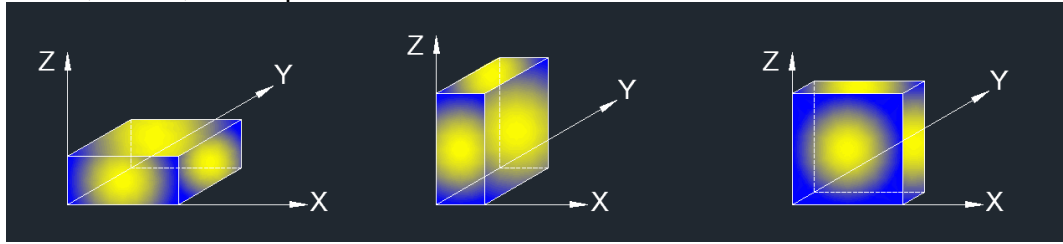

Note: For all radiated test, EUT in each of three orthogonal axis emissions had been tested, but only the worst case (X axis) data recorded in the report.

## 8.1. RESTRICTED BANDEDGE

### RESTRICTED BANDEDGE (LOW CHANNEL, HORIZONTAL)

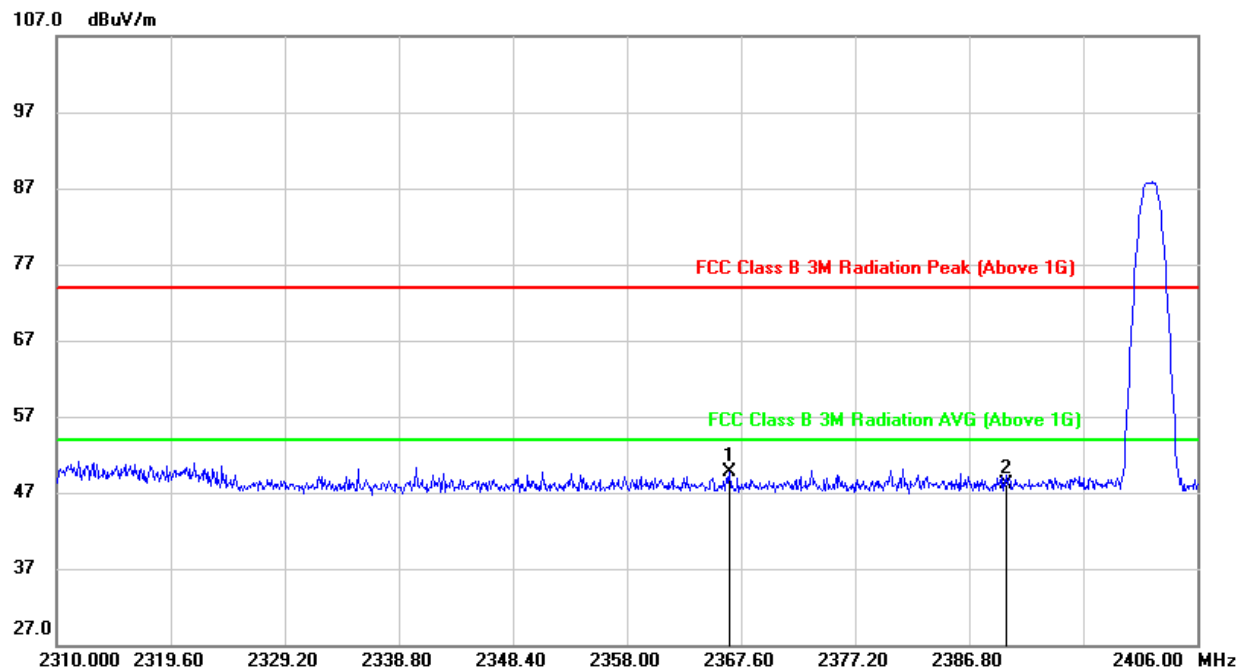

No.	Frequency (MHz)	Reading (dBuV/m)	Correct (dB/m)	Result (dBuV/m)	Limit (dBuV/m)	Margin (dB)	Remark
1	2366.640	16.34	33.31	49.65	74.00	-24.35	peak
2	2390.000	14.90	33.14	48.04	74.00	-25.96	peak

Note: 1. Measurement = Reading Level + Correct Factor.  
 2. If Peak Result complies with AV limit, AV Result is deemed to comply with AV limit.  
 3. Peak: Peak detector.

**RESTRICTED BANDEDGE (LOW CHANNEL, VERTICAL)**

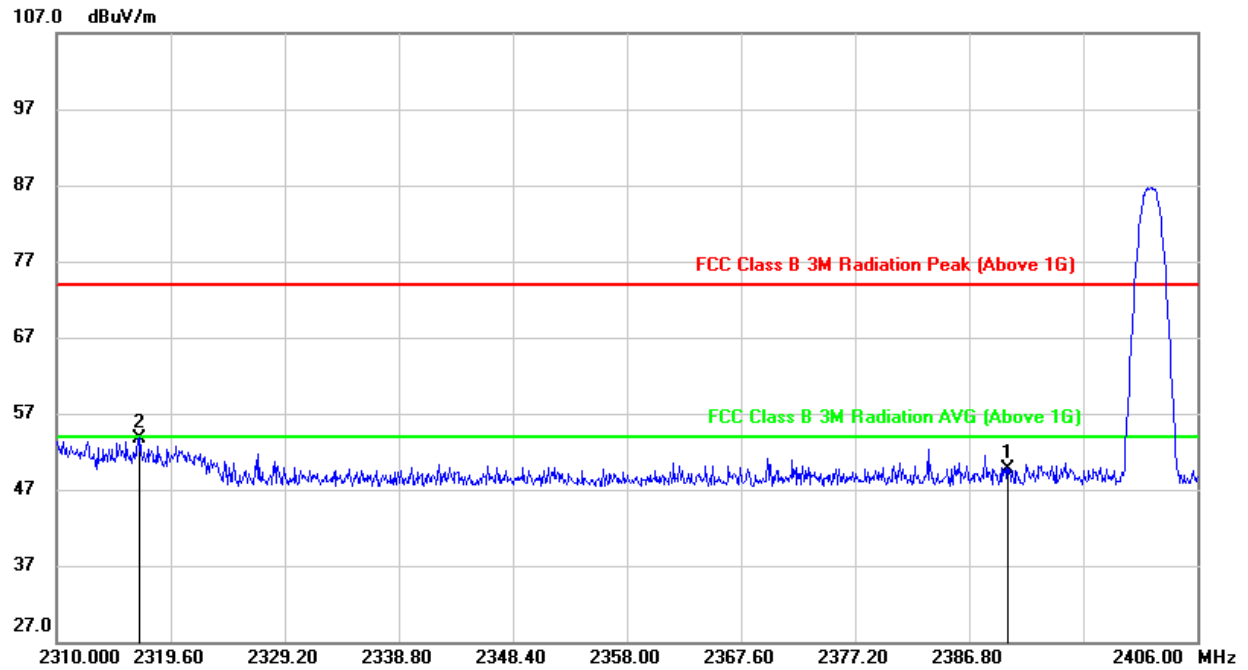

No.	Frequency (MHz)	Reading (dBuV/m)	Correct (dB/m)	Result (dBuV/m)	Limit (dBuV/m)	Margin (dB)	Remark
1	2390.000	16.50	33.24	49.74	74.00	-24.26	peak
2	2317.008	19.97	33.83	53.80	74.00	-20.20	peak

Note: 1. Measurement = Reading Level + Correct Factor.  
 2. If Peak Result complies with AV limit, AV Result is deemed to comply with AV limit.  
 3. Peak: Peak detector.

**RESTRICTED BANDEDGE (HIGH CHANNEL, HORIZONTAL)**

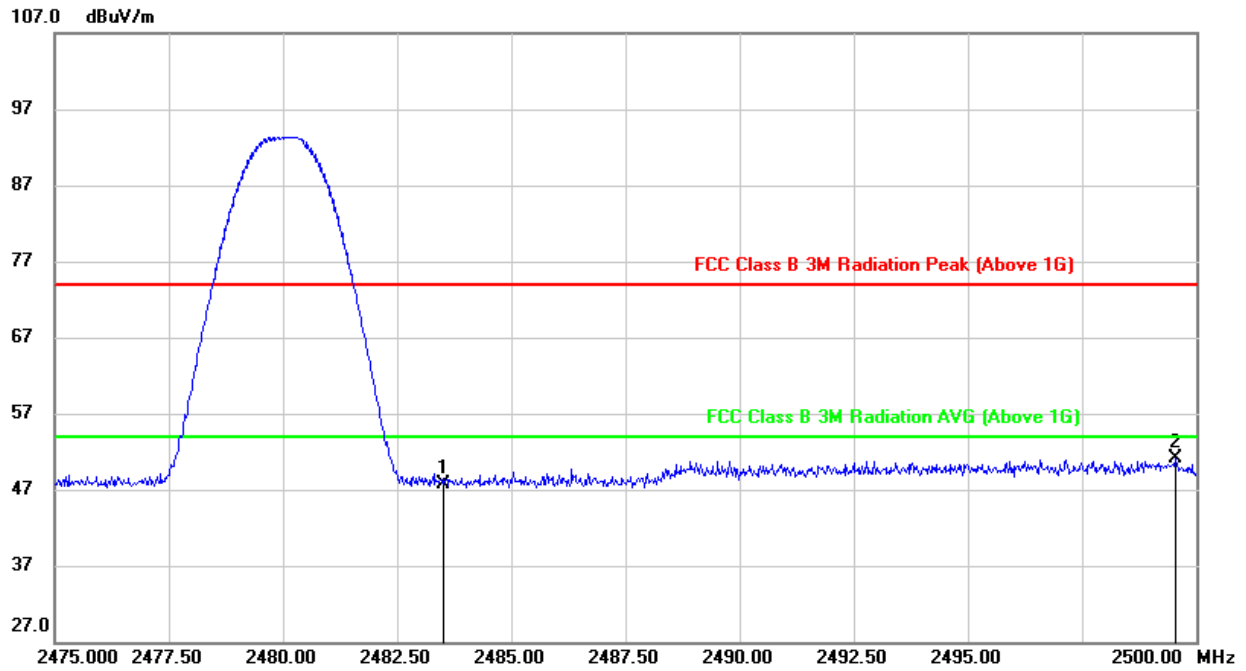

No.	Frequency (MHz)	Reading (dBuV/m)	Correct (dB/m)	Result (dBuV/m)	Limit (dBuV/m)	Margin (dB)	Remark
1	2483.500	15.00	32.78	47.78	74.00	-26.22	peak
2	2499.550	18.24	32.77	51.01	74.00	-22.99	peak

Note: 1. Measurement = Reading Level + Correct Factor.  
 2. If Peak Result complies with AV limit, AV Result is deemed to comply with AV limit.  
 3. Peak: Peak detector.

**RESTRICTED BANDEDGE (HIGH CHANNEL, VERTICAL)**

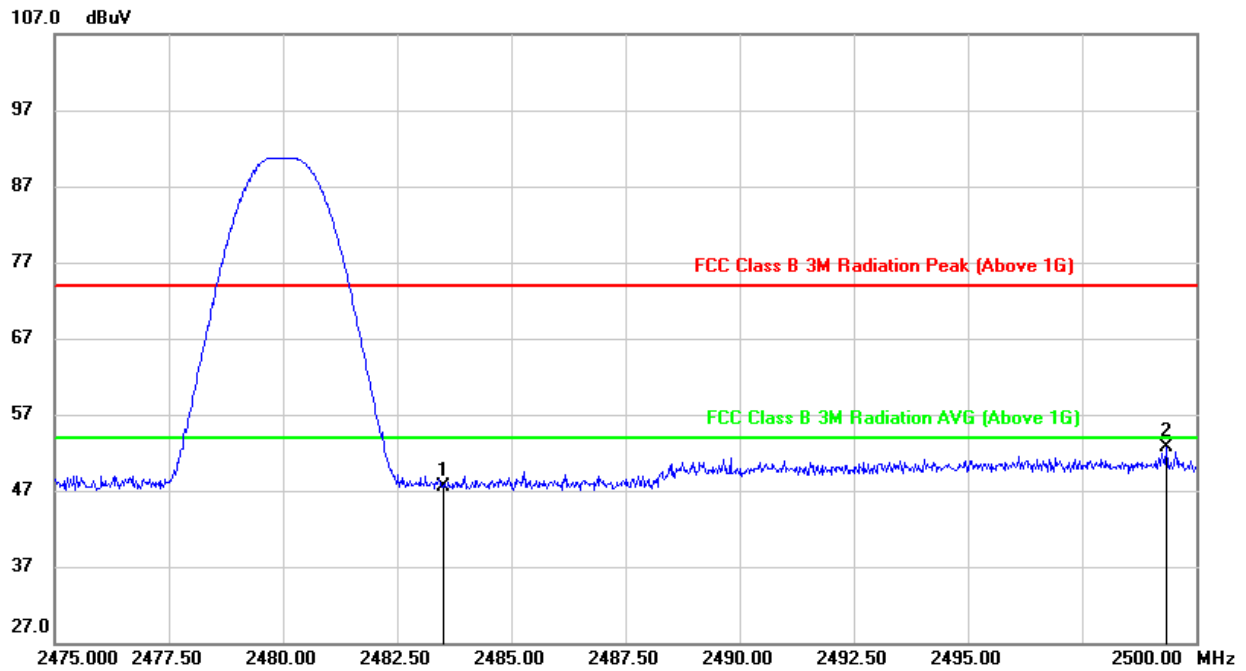

No.	Frequency (MHz)	Reading (dBuV)	Correct (dB)	Result (dBuV)	Limit (dBuV)	Margin (dB)	Remark
1	2483.500	14.62	32.88	47.50	74.00	-26.50	peak
2	2499.350	19.88	32.87	52.75	74.00	-21.25	peak

Note: 1. Measurement = Reading Level + Correct Factor.  
 2. If Peak Result complies with AV limit, AV Result is deemed to comply with AV limit.  
 3. Peak: Peak detector.

## 8.2. SPURIOUS EMISSIONS (1~18GHz)

### HARMONICS AND SPURIOUS EMISSIONS (LOW CHANNEL, HORIZONTAL)

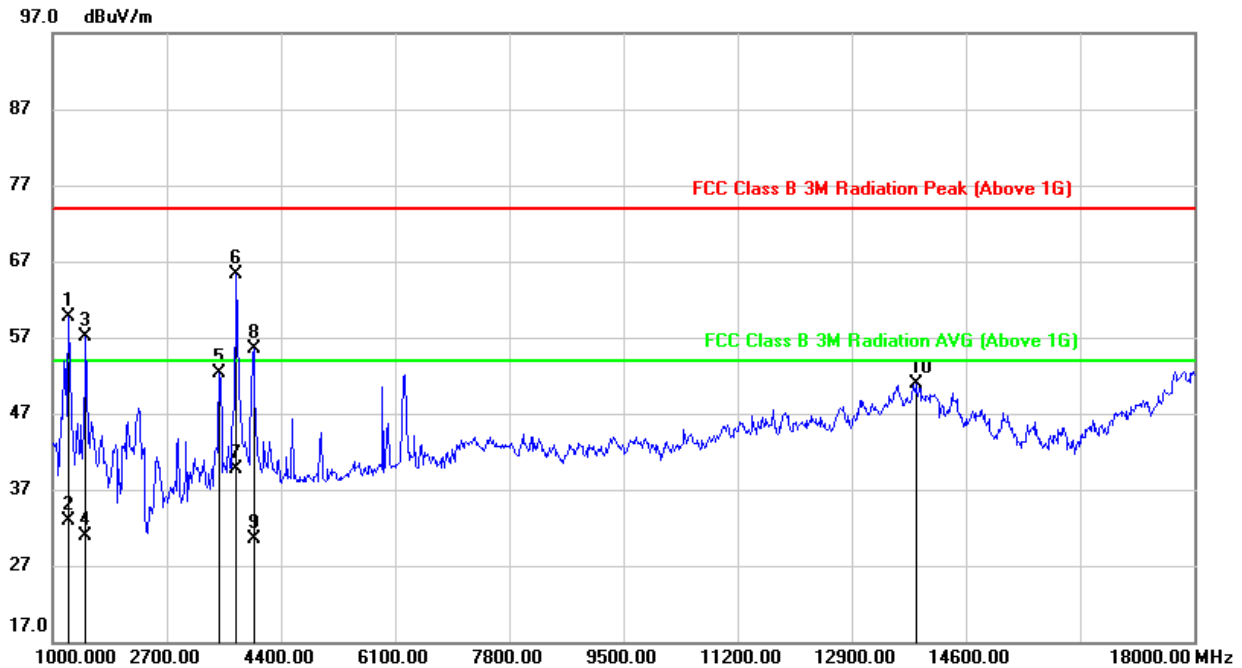

No.	Frequency (MHz)	Reading (dBuV/m)	Correct (dB/m)	Result (dBuV/m)	Limit (dBuV/m)	Margin (dB)	Remark
1	1238.000	72.92	-13.27	59.65	74.00	-14.35	peak
2	1238.000	46.23	-13.27	32.96	54.00	-21.04	AVG
3	1493.000	69.81	-12.68	57.13	74.00	-16.87	peak
4	1493.000	43.56	-12.68	30.88	54.00	-23.12	AVG
5	3482.000	58.34	-6.02	52.32	74.00	-21.68	Peak
6	3737.000	70.19	-4.83	65.36	74.00	-8.64	peak
7	3737.000	44.62	-4.83	39.79	54.00	-14.21	AVG
8	3992.000	60.02	-4.42	55.60	74.00	-18.40	peak
9	3992.000	34.86	-4.42	30.44	54.00	-23.56	AVG
10	13852.000	31.84	19.02	50.86	74.00	-23.14	peak

- Note: 1. Peak Result = Reading Level + Correct Factor.  
 2. If Peak Result complies with AV limit, AV Result is deemed to comply with AV limit.  
 3. Peak: Peak detector.  
 4. AVG: VBW=10Hz.  
 5. For transmit duration, please refer to clause 7.1.

**HARMONICS AND SPURIOUS EMISSIONS (LOW CHANNEL, VERTICAL)**

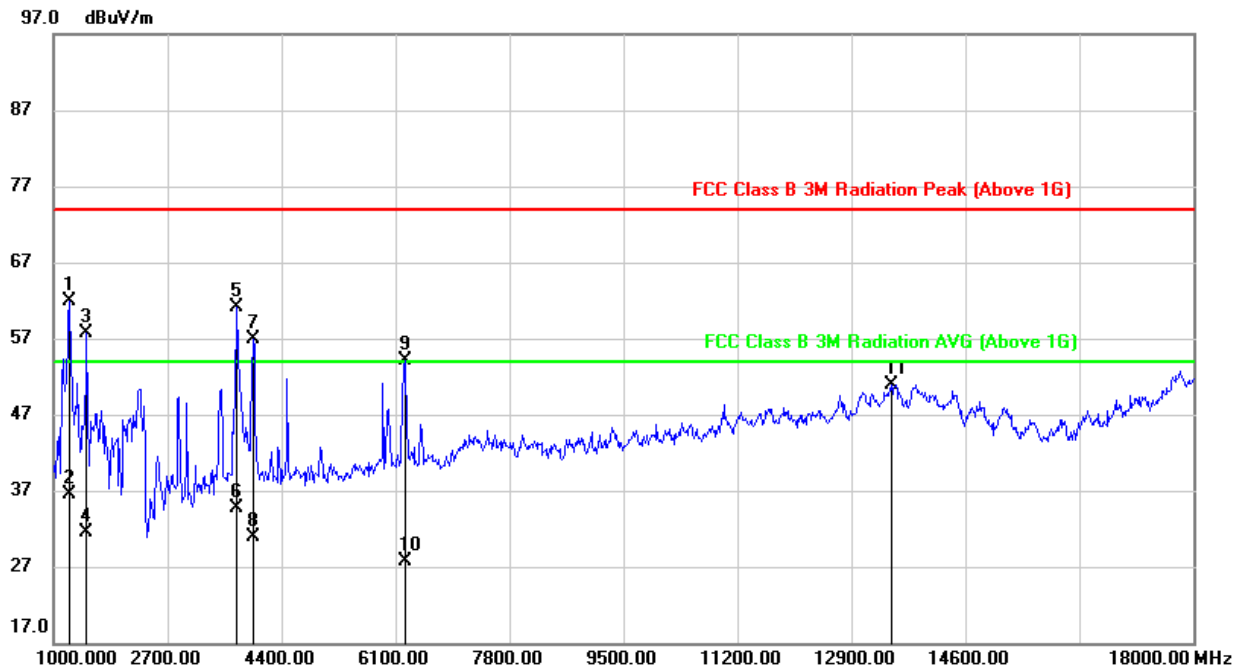

No.	Frequency (MHz)	Reading (dBuV/m)	Correct dB/m	Result (dBuV/m)	Limit (dBuV/m)	Margin (dB)	Remark
1	1238.000	75.18	-13.22	61.96	74.00	-12.04	peak
2	1238.000	49.68	-13.22	36.46	54.00	-17.54	AVG
3	1493.000	70.57	-12.77	57.80	74.00	-16.20	peak
4	1493.000	44.21	-12.77	31.44	74.00	-42.56	peak
5	3737.000	65.92	-4.81	61.11	74.00	-12.89	peak
6	3737.000	39.54	-4.81	34.73	54.00	-19.27	AVG
7	3975.000	61.33	-4.42	56.91	74.00	-17.09	peak
8	3975.000	35.32	-4.42	30.90	54.00	-23.10	AVG
9	6236.000	51.24	2.89	54.13	74.00	-19.87	peak
10	6236.000	24.81	2.89	27.70	54.00	-26.30	AVG
11	13495.000	31.80	19.03	50.83	74.00	-23.17	peak

Note: 1. Peak Result = Reading Level + Correct Factor.  
 2. If Peak Result complies with AV limit, AV Result is deemed to comply with AV limit.  
 3. Peak: Peak detector.  
 4. AVG: VBW=10Hz.  
 5. For transmit duration, please refer to clause 7.1.



**HARMONICS AND SPURIOUS EMISSIONS (MID CHANNEL, HORIZONTAL)**

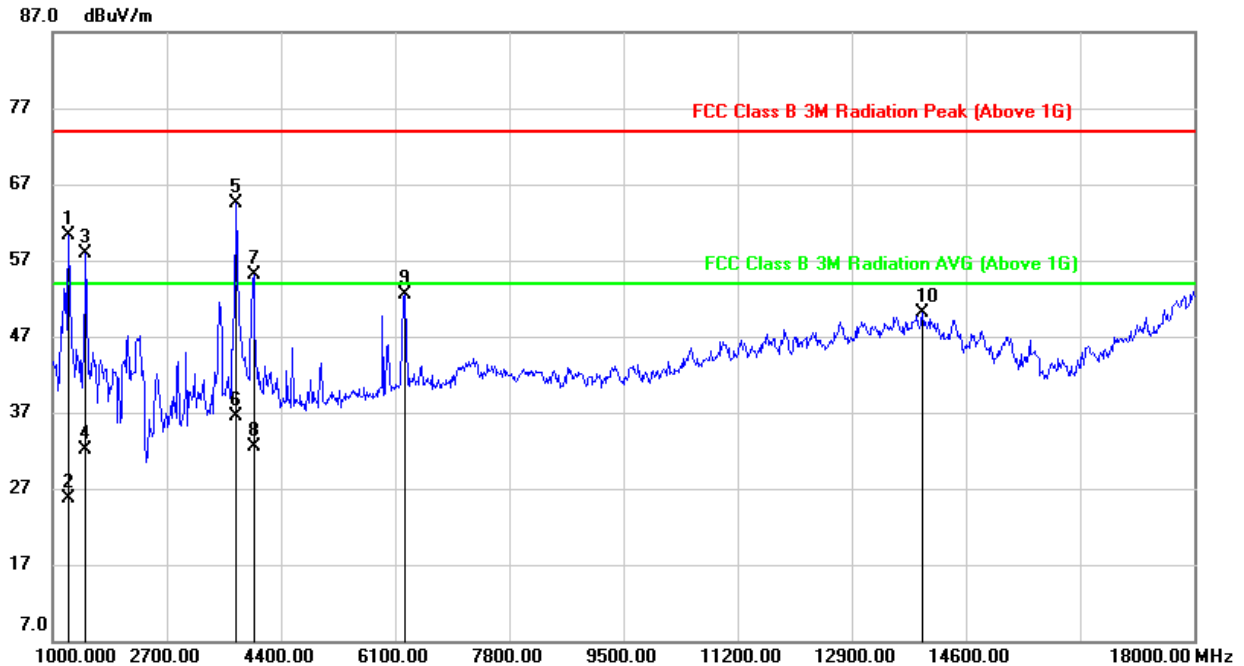

No.	Frequency (MHz)	Reading (dBuV/m)	Correct (dB/m)	Result (dBuV/m)	Limit (dBuV/m)	Margin (dB)	Remark
1	1238.000	73.57	-13.27	60.30	74.00	-13.70	peak
2	1238.000	38.92	-13.27	25.65	54.00	-28.35	AVG
3	1493.000	70.66	-12.68	57.98	74.00	-16.02	peak
4	1493.000	44.87	-12.68	32.19	54.00	-21.81	AVG
5	3737.000	69.40	-4.83	64.57	74.00	-9.43	peak
6	3737.000	41.28	-4.83	36.45	54.00	-17.55	AVG
7	3992.000	59.56	-4.42	55.14	74.00	-18.86	peak
8	3992.000	36.95	-4.42	32.53	54.00	-21.47	AVG
9	6253.000	49.71	2.87	52.58	74.00	-21.42	peak
10	13954.000	31.07	18.96	50.03	74.00	-23.97	peak

- Note: 1. Peak Result = Reading Level + Correct Factor.  
 2. If Peak Result complies with AV limit, AV Result is deemed to comply with AV limit.  
 3. Peak: Peak detector.  
 4. AVG: VBW=10Hz.  
 5. For transmit duration, please refer to clause 7.1.

**HARMONICS AND SPURIOUS EMISSIONS (MID CHANNEL, VERTICAL)**

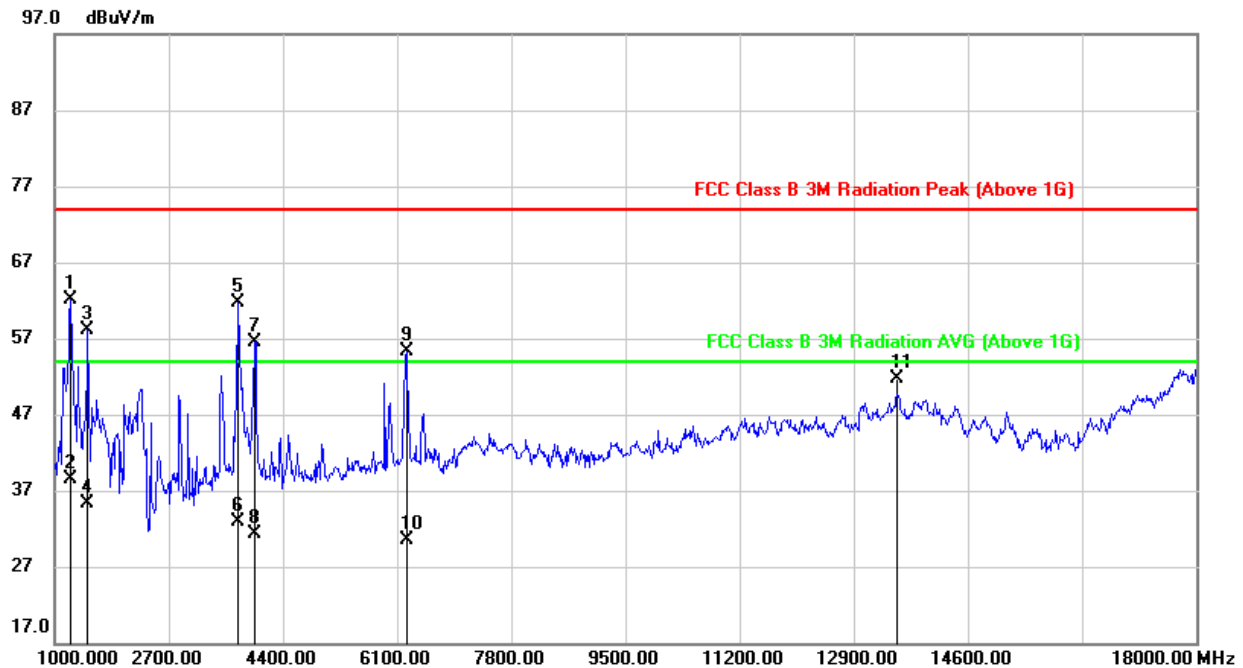

No.	Frequency (MHz)	Reading (dBuV/m)	Correct dB/m	Result (dBuV/m)	Limit (dBuV/m)	Margin (dB)	Remark
1	1238.000	75.32	-13.22	62.10	74.00	-11.90	peak
2	1238.000	51.67	-13.22	38.45	54.00	-15.55	AVG
3	1493.000	70.95	-12.77	58.18	74.00	-15.82	peak
4	1493.000	47.98	-12.77	35.21	54.00	-18.79	AVG
5	3737.000	66.46	-4.81	61.65	74.00	-12.35	peak
6	3737.000	37.66	-4.81	32.85	54.00	-21.15	AVG
7	3975.000	60.93	-4.42	56.51	74.00	-17.49	peak
8	3975.000	35.68	-4.42	31.26	54.00	-22.74	AVG
9	6236.000	52.34	2.89	55.23	74.00	-18.77	peak
10	6236.000	27.62	2.89	30.51	54.00	-23.49	AVG
11	13546.000	32.25	19.38	51.63	74.00	-22.37	peak

Note: 1. Peak Result = Reading Level + Correct Factor.  
 2. If Peak Result complies with AV limit, AV Result is deemed to comply with AV limit.  
 3. Peak: Peak detector.  
 4. AVG: VBW=10Hz.  
 5. For transmit duration, please refer to clause 7.1.

**HARMONICS AND SPURIOUS EMISSIONS (HIGH CHANNEL, HORIZONTAL)**

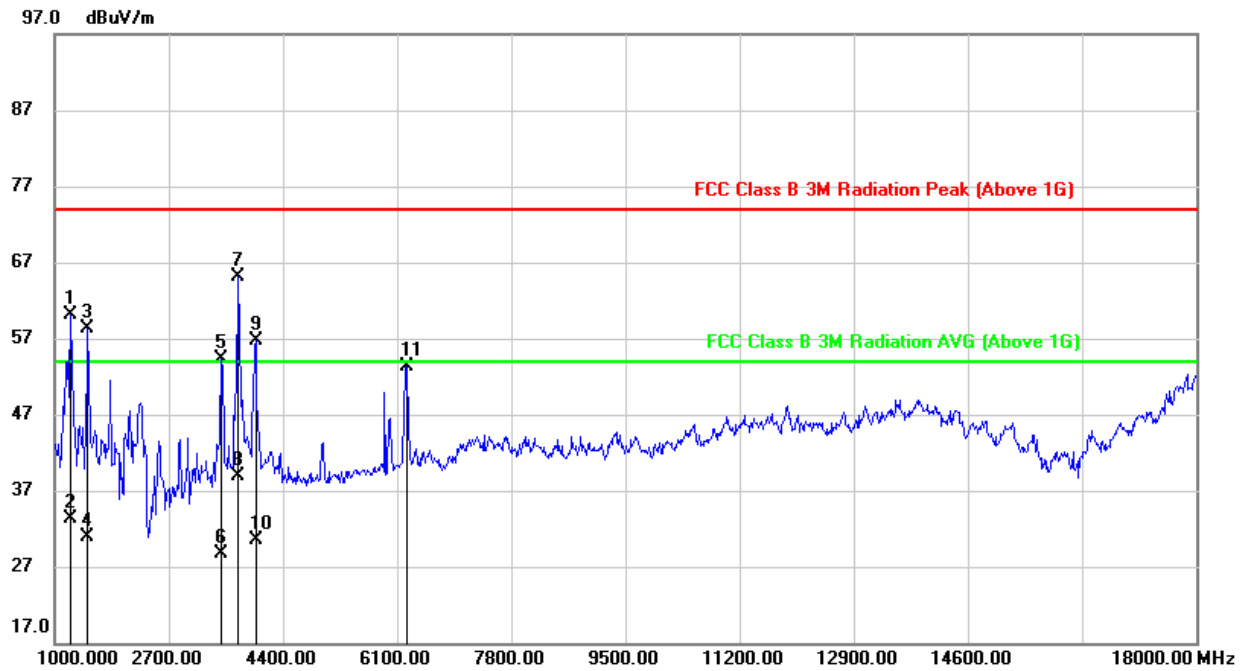

No.	Frequency (MHz)	Reading (dBuV/m)	Correct (dB/m)	Result (dBuV/m)	Limit (dBuV/m)	Margin (dB)	Remark
1	1238.000	73.41	-13.27	60.14	74.00	-13.86	peak
2	1238.000	46.56	-13.27	33.29	54.00	-20.71	AVG
3	1493.000	70.98	-12.68	58.30	74.00	-15.70	peak
4	1493.000	43.68	-12.68	31.00	54.00	-23.00	AVG
5	3482.000	60.27	-6.02	54.25	74.00	-19.75	peak
6	3482.000	34.78	-6.02	28.76	54.00	-25.24	AVG
7	3737.000	70.02	-4.83	65.19	74.00	-8.81	peak
8	3737.000	43.65	-4.83	38.82	54.00	-15.18	AVG
9	3992.000	61.13	-4.42	56.71	74.00	-17.29	peak
10	3992.000	34.85	-4.42	30.43	54.00	-23.57	AVG
11	6253.000	50.36	2.87	53.23	74.00	-20.77	peak

Note: 1. Peak Result = Reading Level + Correct Factor.  
 2. If Peak Result complies with AV limit, AV Result is deemed to comply with AV limit.  
 3. Peak: Peak detector.  
 4. AVG: VBW=10Hz.  
 5. For transmit duration, please refer to clause 7.1.

**HARMONICS AND SPURIOUS EMISSIONS (HIGH CHANNEL, VERTICAL)**

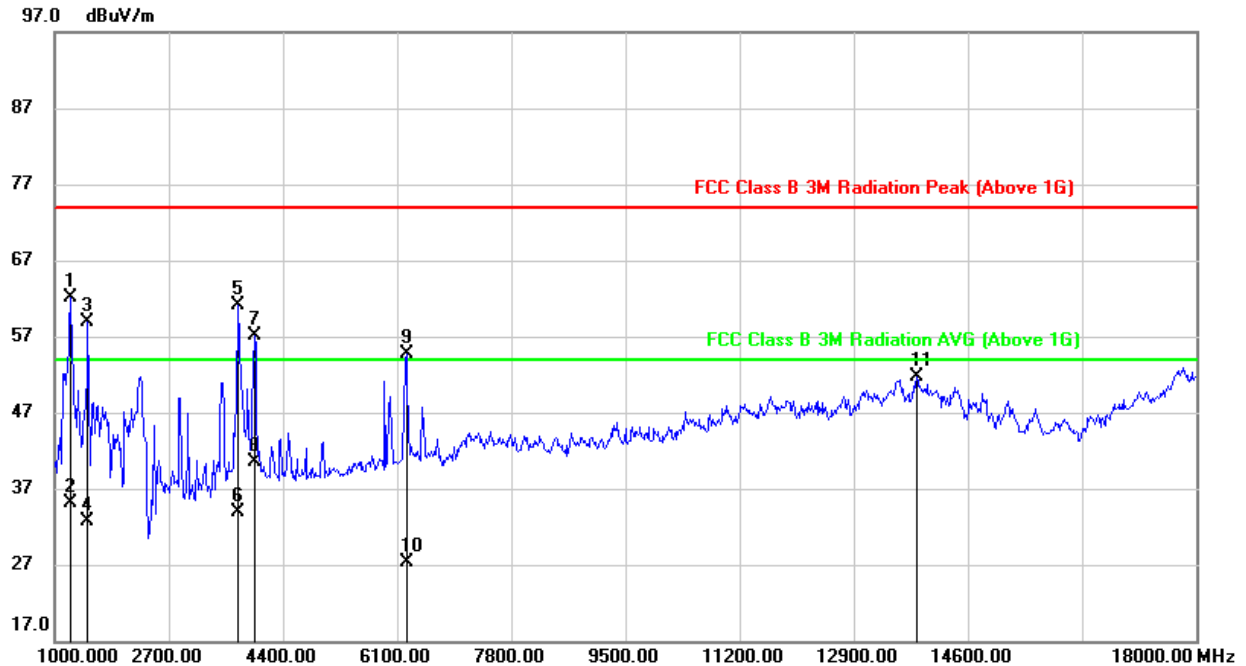

No.	Frequency (MHz)	Reading (dBuV/m)	Correct dB/m	Result (dBuV/m)	Limit (dBuV/m)	Margin (dB)	Remark
1	1238.000	75.40	-13.22	62.18	74.00	-11.82	peak
2	1238.000	48.36	-13.22	35.14	54.00	-18.86	AVG
3	1493.000	71.76	-12.77	58.99	74.00	-15.01	peak
4	1493.000	45.46	-12.77	32.69	54.00	-21.31	AVG
5	3737.000	65.87	-4.81	61.06	74.00	-12.94	peak
6	3737.000	38.65	-4.81	33.84	54.00	-20.16	AVG
7	3975.000	61.45	-4.42	57.03	74.00	-16.97	peak
8	3975.000	44.85	-4.42	40.43	54.00	-13.57	AVG
9	6236.000	51.79	2.89	54.68	74.00	-19.32	peak
10	6236.000	24.37	2.89	27.26	54.00	-26.74	AVG
11	13835.000	32.46	19.30	51.76	74.00	-22.24	peak

- Note: 1. Peak Result = Reading Level + Correct Factor.  
 2. If Peak Result complies with AV limit, AV Result is deemed to comply with AV limit.  
 3. Peak: Peak detector.  
 4. AVG: VBW=10Hz.  
 5. For transmit duration, please refer to clause 7.1.

### 8.3. SPURIOUS EMISSIONS 18G ~ 26GHZ

#### SPURIOUS EMISSIONS (MID CHANNEL, WORST-CASE CONFIGURATION, HORIZONTAL)

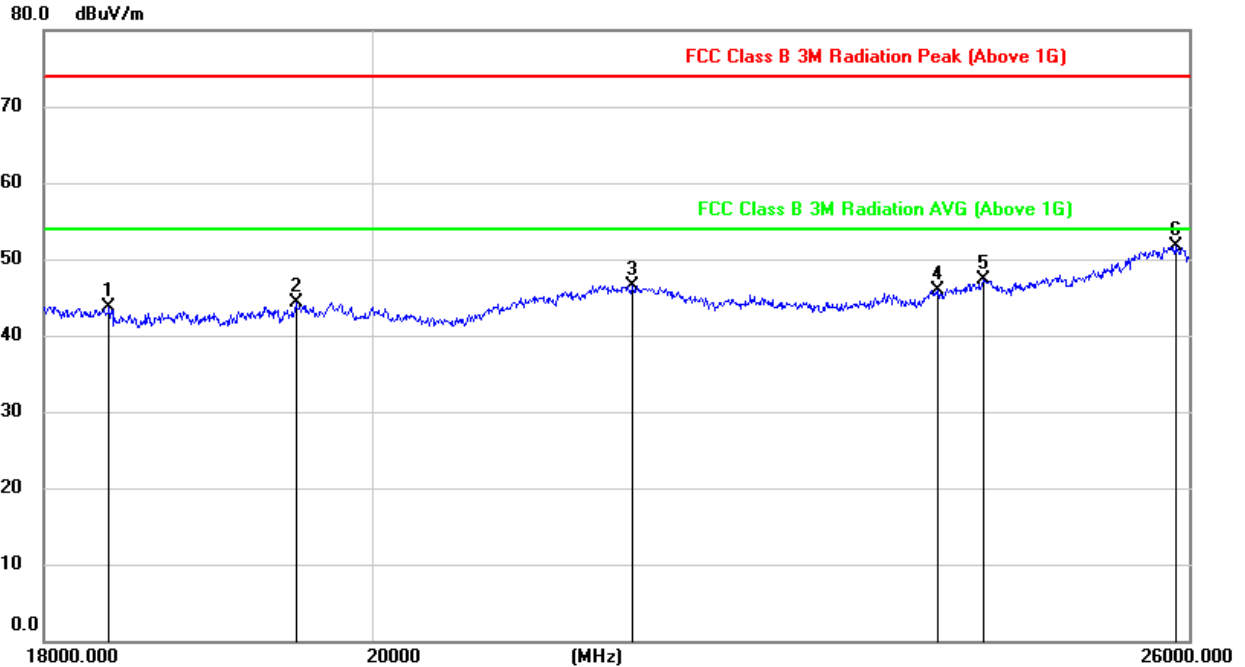

No.	Frequency (MHz)	Reading (dBuV/m)	Correct dB/m	Result (dBuV/m)	Limit (dBuV/m)	Margin (dB)	Remark
1	18381.267	49.15	-5.40	43.75	74.00	-30.25	peak
2	19516.714	49.81	-5.53	44.28	74.00	-29.72	peak
3	21744.966	50.83	-4.34	46.49	74.00	-27.51	peak
4	23988.266	48.67	-2.77	45.90	74.00	-28.10	peak
5	24334.767	49.95	-2.65	47.30	74.00	-26.70	peak
6	25885.523	52.48	-0.86	51.62	74.00	-22.38	peak

- Note: 1. Peak Result = Reading Level + Correct Factor.  
 2. If Peak Result complies with AV limit, AV Result is deemed to comply with AV limit.  
 3. Peak: Peak detector.  
 4. All the modes had been tested, but only the worst data were recorded in the report.

**SPURIOUS EMISSIONS (MID CHANNEL, WORST-CASE CONFIGURATION, VERTICAL)**

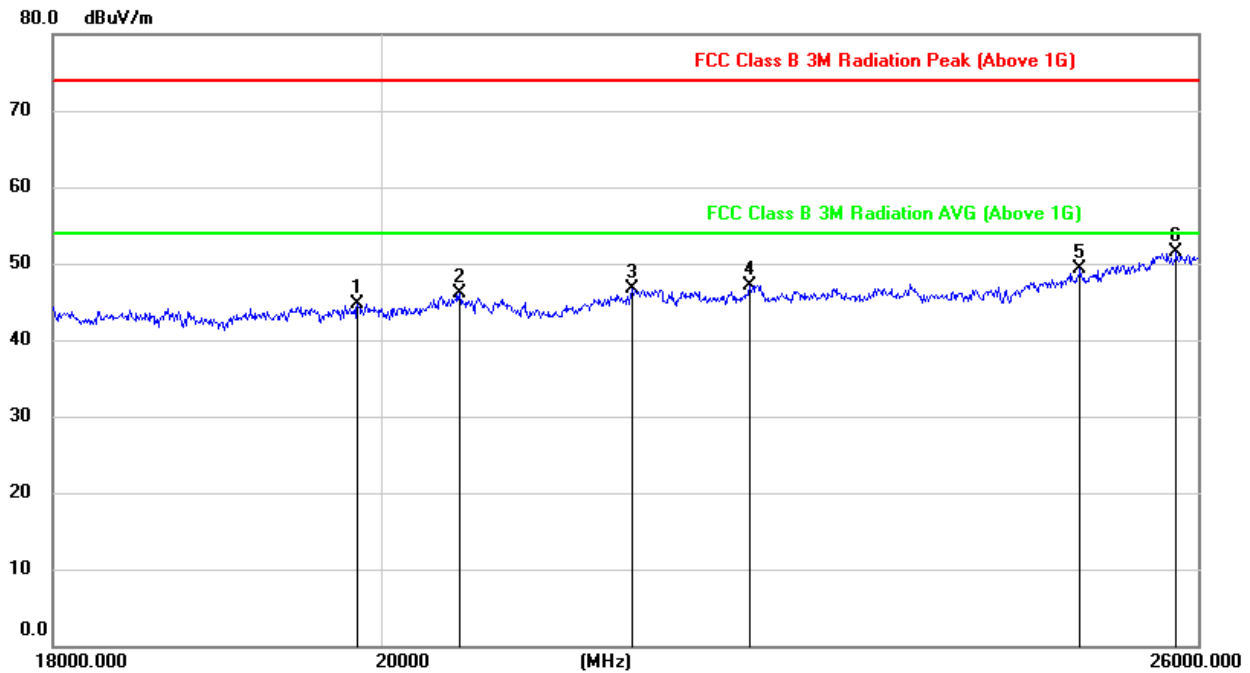

No.	Frequency (MHz)	Reading (dBuV/m)	Correct dB/m	Result (dBuV/m)	Limit (dBuV/m)	Margin (dB)	Remark
1	19849.654	50.09	-5.33	44.76	74.00	-29.24	peak
2	20510.030	51.36	-5.35	46.01	74.00	-27.99	peak
3	21681.091	51.10	-4.43	46.67	74.00	-27.33	peak
4	22518.026	51.05	-3.87	47.18	74.00	-26.82	peak
5	25033.649	51.32	-2.04	49.28	74.00	-24.72	peak
6	25818.977	52.23	-0.74	51.49	74.00	-22.51	peak

- Note: 1. Peak Result = Reading Level + Correct Factor.  
 2. If Peak Result complies with AV limit, AV Result is deemed to comply with AV limit.  
 3. Peak: Peak detector.  
 4. All the modes had been tested, but only the worst data were recorded in the report.

### 8.4. SPURIOUS EMISSIONS 30M ~ 1 GHz

#### SPURIOUS EMISSIONS (MID CHANNEL, WORST-CASE CONFIGURATION, HORIZONTAL)

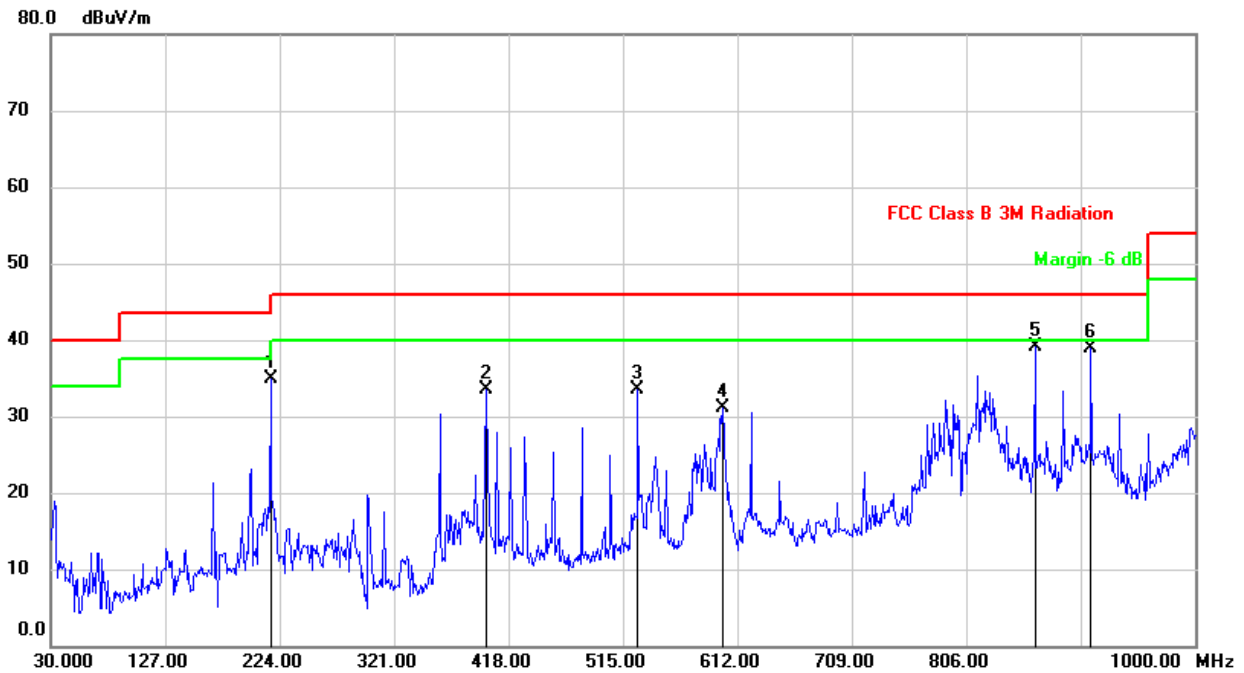

No.	Frequency (MHz)	Reading (dBuV/m)	Correct dB/m	Result (dBuV/m)	Limit (dBuV/m)	Margin (dB)	Remark
1	216.2400	63.30	-28.45	34.85	46.00	-11.15	QP
2	398.6000	58.69	-25.15	33.54	46.00	-12.46	QP
3	527.6100	55.06	-21.55	33.51	46.00	-12.49	QP
4	599.3900	50.95	-19.84	31.11	46.00	-14.89	QP
5	864.2000	56.28	-17.13	39.15	46.00	-6.85	QP
6	911.7300	55.14	-16.20	38.94	46.00	-7.06	QP

Note: 1. Result Level = Read Level + Correct Factor.  
 2. If Peak Result complies with QP limit, QP Result is deemed to comply with QP limit.  
 3. Test setup: RBW: 120 kHz, VBW: 300 kHz, Sweep time: auto.

**SPURIOUS EMISSIONS (MID CHANNEL, WORST-CASE CONFIGURATION, VERTICAL)**

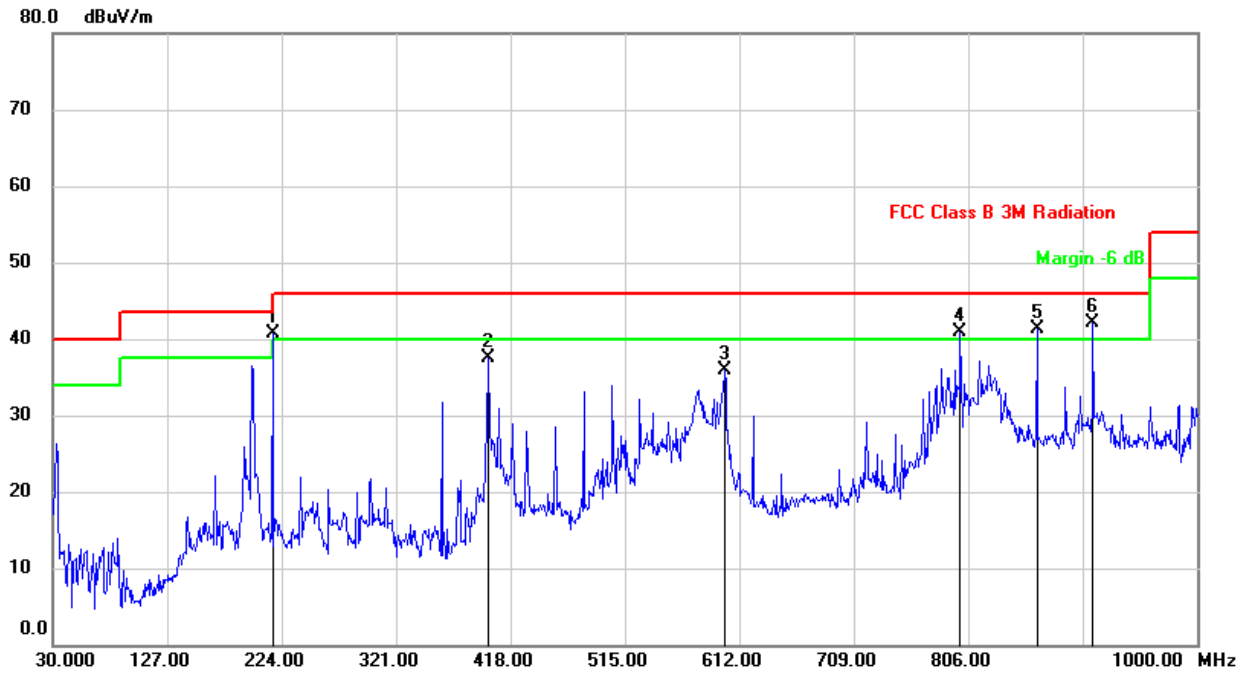

No.	Frequency (MHz)	Reading (dBuV/m)	Correct dB/m	Result (dBuV/m)	Limit (dBuV/m)	Margin (dB)	Remark
1	216.2400	69.10	-28.45	40.65	46.00	-5.35	QP
2	399.5700	62.60	-25.15	37.45	46.00	-8.55	QP
3	599.3900	55.69	-19.84	35.85	46.00	-10.15	QP
4	799.2100	60.51	-19.60	40.91	46.00	-5.09	QP
5	864.2000	58.47	-17.13	41.34	46.00	-4.66	QP
6	911.7300	58.26	-16.20	42.06	46.00	-3.94	QP

- Note: 1. Result Level = Read Level + Correct Factor.  
 2. If Peak Result complies with QP limit, QP Result is deemed to comply with QP limit.  
 3. Test setup: RBW: 120 kHz, VBW: 300 kHz, Sweep time: auto



## 8.5. SPURIOUS EMISSIONS BELOW 30M

### SPURIOUS EMISSIONS (MID CHANNEL, WORST-CASE CONFIGURATION, HORIZONTAL)

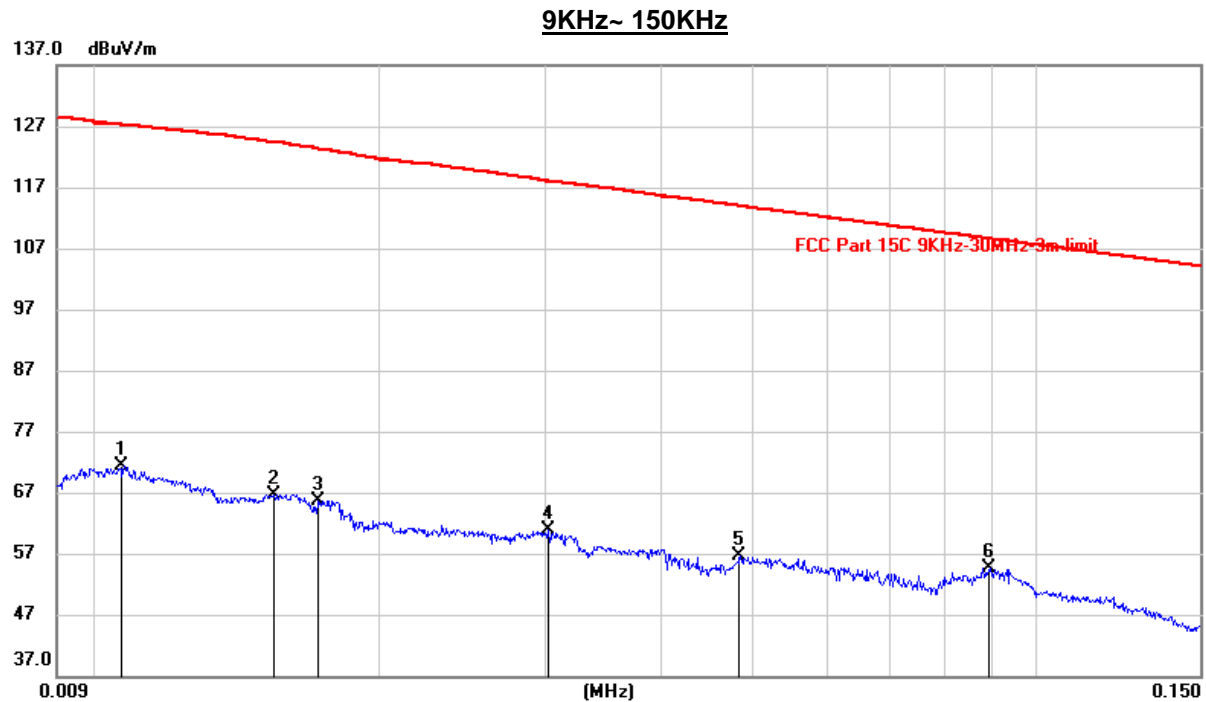

No.	Frequency (MHz)	Reading (dBuV/m)	Correct dB/m	Result (dBuV/m)	Limit (dBuV/m)	Margin (dB)	Remark
1	0.0106	51.04	20.22	71.26	127.24	-55.98	peak
2	0.0154	46.48	20.26	66.74	124.35	-57.61	peak
3	0.0171	45.46	20.28	65.74	123.33	-57.59	peak
4	0.0302	40.46	20.31	60.77	118.01	-57.24	peak
5	0.0483	36.31	20.31	56.62	113.95	-57.33	peak
6	0.0892	34.45	20.25	54.70	108.60	-53.90	peak

Note: 1. Measurement = Reading Level + Correct Factor.  
 2. All the modes had been tested, but only the worst data were recorded in the report.  
 3. If Peak Result complies with AV and QP limit, AV and QP Result are deemed to comply with AV limit.

**150KHz ~ 30M**

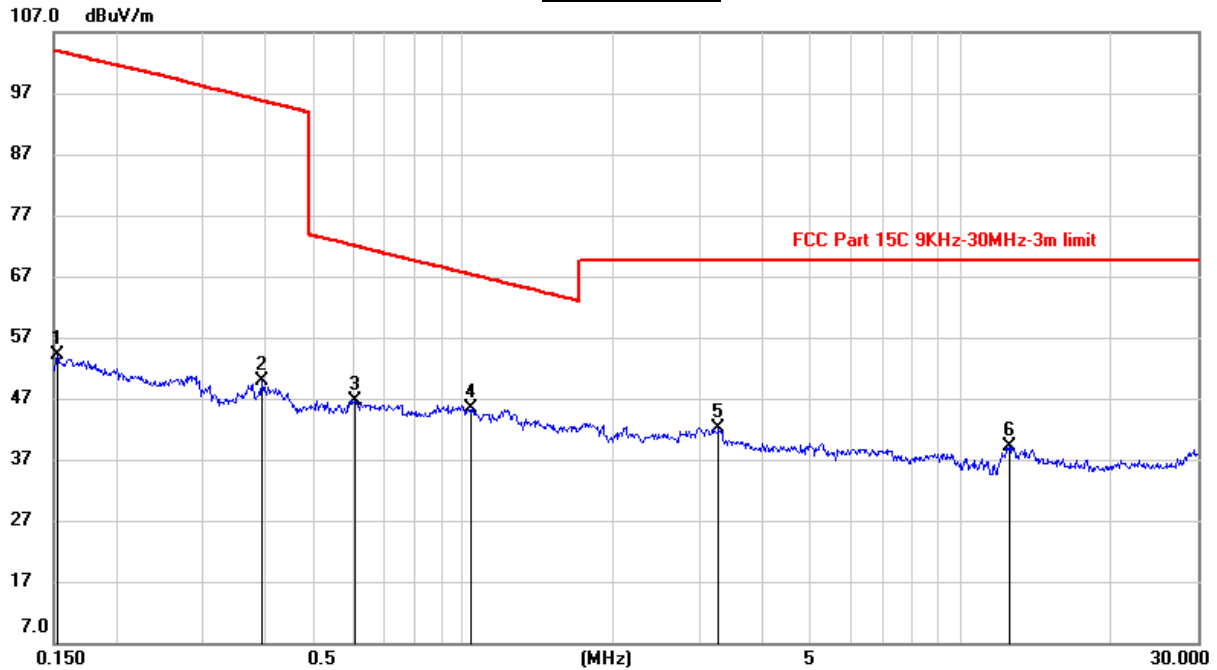

No.	Frequency (MHz)	Reading (dBuV/m)	Correct dB/m	Result (dBuV/m)	Limit (dBuV/m)	Margin (dB)	Remark
1	0.1524	33.66	20.42	54.08	103.95	-49.87	peak
2	0.3933	29.49	20.27	49.76	95.73	-45.97	peak
3	0.6038	26.43	20.29	46.72	71.99	-25.27	peak
4	1.0423	25.03	20.38	45.41	67.25	-21.84	peak
5	3.2755	21.26	20.94	42.20	69.54	-27.34	peak
6	12.5820	18.19	21.00	39.19	69.54	-30.35	peak

- Note: 1. Measurement = Reading Level + Correct Factor.  
 2. All the modes had been tested, but only the worst data were recorded in the report.  
 3. If Peak Result complies with AV and QP limit, AV and QP Result are deemed to comply with AV limit.

**SPURIOUS EMISSIONS (MID CHANNEL, WORST-CASE CONFIGURATION, VERTICAL)**

**9KHz~ 150KHz**

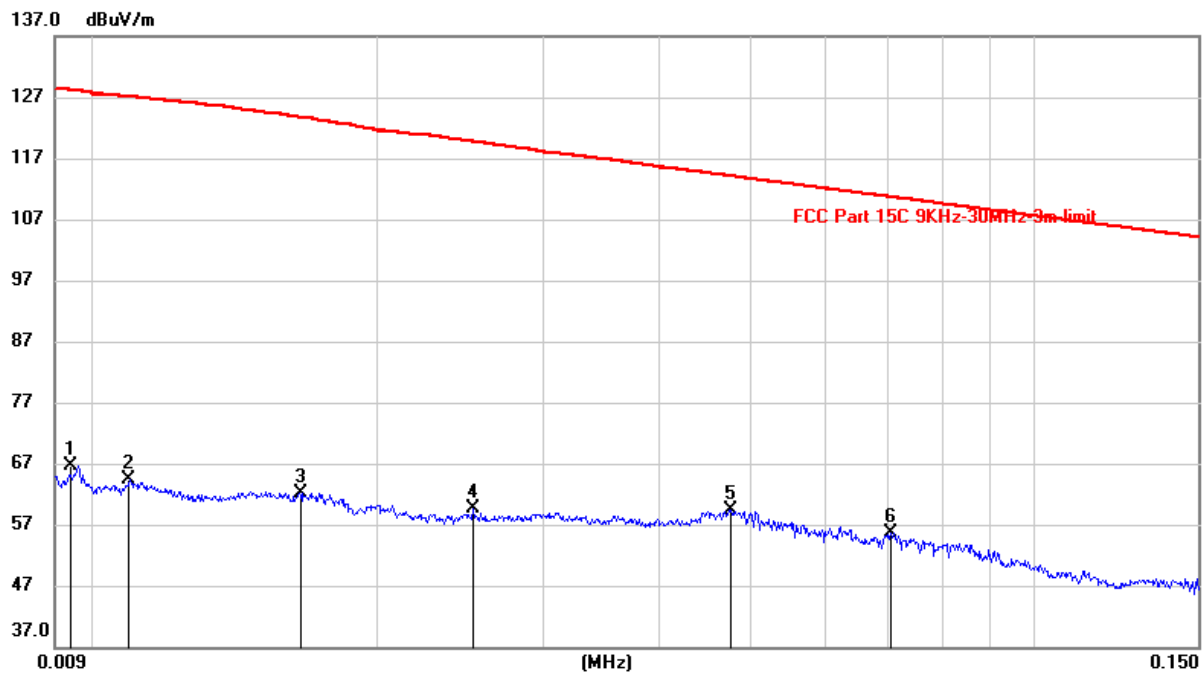

No.	Frequency (MHz)	Reading (dBuV/m)	Correct dB/m	Result (dBuV/m)	Limit (dBuV/m)	Margin (dB)	Remark
1	0.0094	46.40	20.26	66.66	128.06	-61.40	peak
2	0.0108	44.24	20.22	64.46	127.12	-62.66	peak
3	0.0165	41.97	20.27	62.24	123.69	-61.45	peak
4	0.0252	39.29	20.31	59.60	119.75	-60.15	peak
5	0.0475	39.14	20.31	59.45	114.11	-54.66	peak
6	0.0704	35.36	20.31	55.67	110.65	-54.98	peak

Note: 1. Measurement = Reading Level + Correct Factor.  
 2. All the modes had been tested, but only the worst data were recorded in the report.  
 3. If Peak Result complies with AV and QP limit, AV and QP Result are deemed to comply with AV limit.

**150KHz ~ 30M**

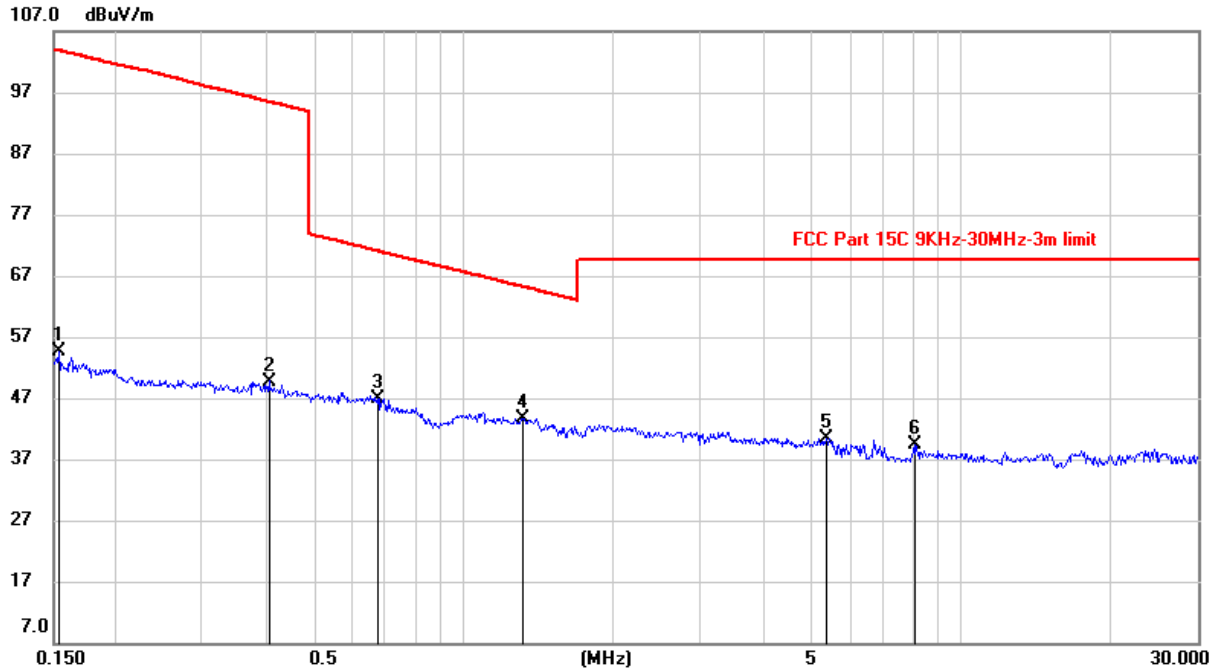

No.	Frequency (MHz)	Reading (dBuV/m)	Correct dB/m	Result (dBuV/m)	Limit (dBuV/m)	Margin (dB)	Remark
1	0.1539	34.32	20.42	54.74	103.86	-49.12	peak
2	0.4061	29.48	20.27	49.75	95.44	-45.69	peak
3	0.6719	26.57	20.32	46.89	71.08	-24.19	peak
4	1.3237	23.23	20.49	43.72	65.18	-21.46	peak
5	5.3900	19.56	20.84	40.40	69.54	-29.14	peak
6	8.0624	18.39	20.97	39.36	69.54	-30.18	peak

Note: 1. Measurement = Reading Level + Correct Factor.  
 2. All the modes had been tested, but only the worst data were recorded in the report.  
 3. If Peak Result complies with AV and QP limit, AV and QP Result are deemed to comply with AV limit.

## 9. AC POWER LINE CONDUCTED EMISSIONS

### LIMITS

Please refer to FCC §15.207 (a) and RSS-Gen Clause 8.8

FREQUENCY (MHz)	Class A (dBuV)		Class B (dBuV)	
	Quasi-peak	Average	Quasi-peak	Average
0.15 -0.5	79.00	66.00	66 - 56 *	56 - 46 *
0.50 -5.0	73.00	60.00	56.00	46.00
5.0 -30.0	73.00	60.00	60.00	50.00

### TEST SETUP AND PROCEDURE

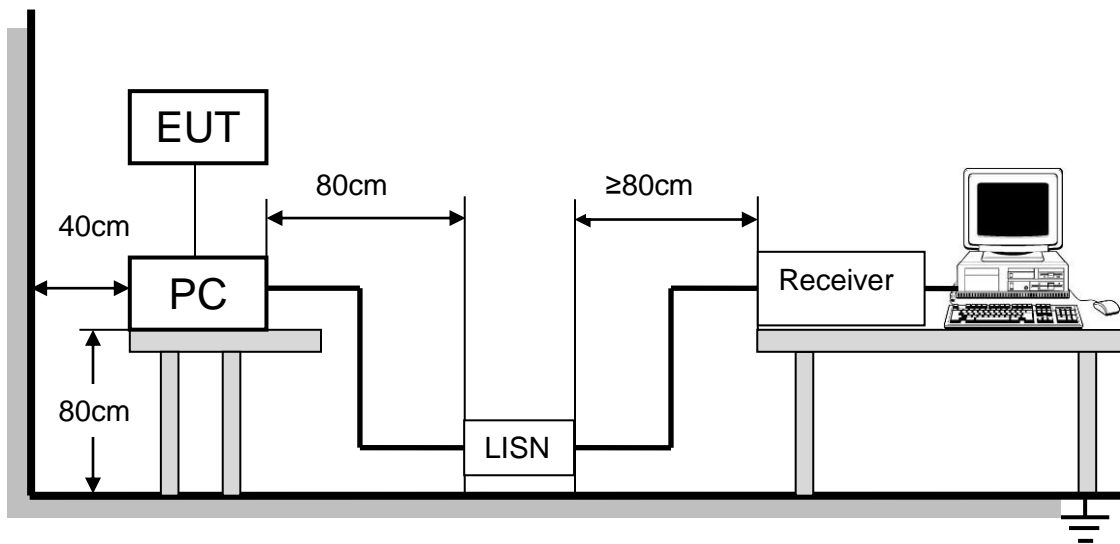

The EUT is put on a table of non-conducting material that is 80cm high. The vertical conducting wall of shielding is located 40cm to the rear of the EUT. The power line of the EUT is connected to the AC mains through a Artificial Mains Network (A.M.N.). A EMI Measurement Receiver (R&S Test Receiver ESR3) is used to test the emissions from both sides of AC line. According to the requirements in Section 6.2 of ANSI C63.10-2003. Conducted emissions from the EUT measured in the frequency range between 0.15 MHz and 30MHz using CISPR Quasi-Peak and average detector mode. The bandwidth of EMI test receiver is set at 9kHz. The arrangement of the equipment is installed to meet the standards and operating in a manner, which tends to maximize its emission characteristics in a normal application.

**LINE N RESULTS (LOW CHANNEL, WORST-CASE CONFIGURATION)**

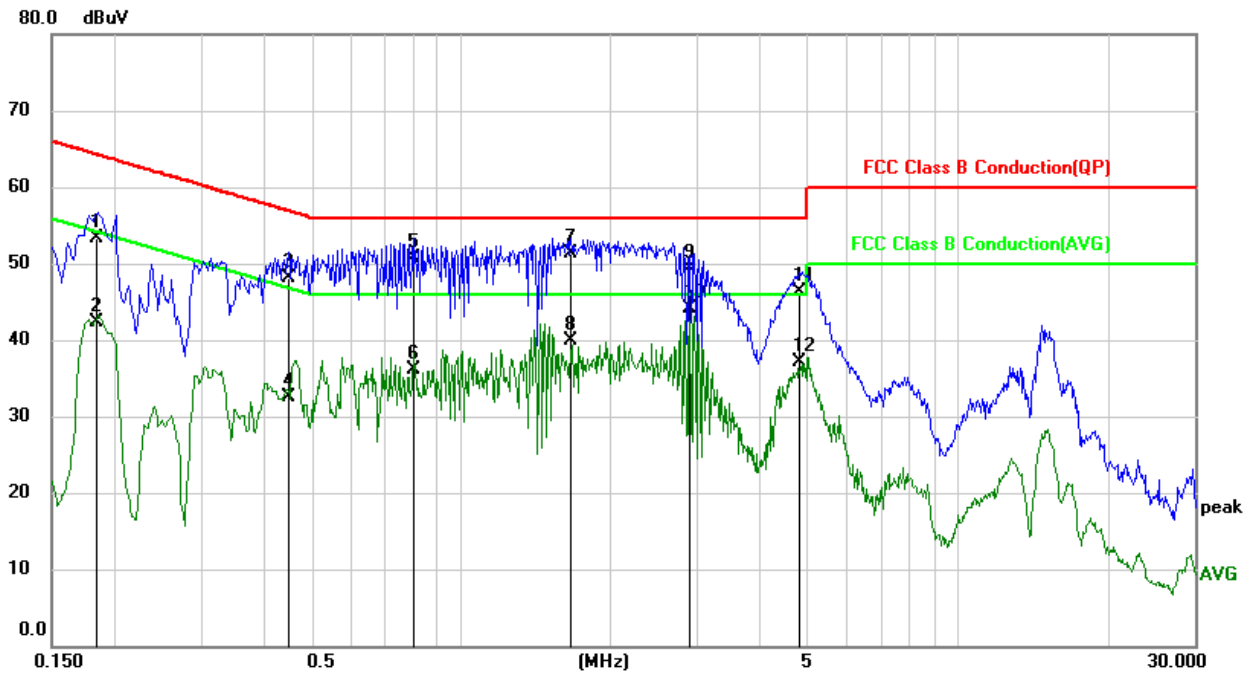

No.	Frequency (MHz)	Reading (dBuV)	Correct dB	Result (dBuV)	Limit (dBuV)	Margin (dB)	Remark
1	0.1840	43.74	9.64	53.38	64.30	-10.92	QP
2	0.1840	32.63	9.64	42.27	54.30	-12.03	AVG
3	0.4501	38.46	9.65	48.11	56.87	-8.76	QP
4	0.4501	22.86	9.65	32.51	46.87	-14.36	AVG
5	0.8007	41.09	9.67	50.76	56.00	-5.24	QP
6	0.8007	26.43	9.67	36.10	46.00	-9.90	AVG
7	1.6714	41.70	9.68	51.38	56.00	-4.62	QP
8	1.6714	30.24	9.68	39.92	46.00	-6.08	AVG
9	2.8860	39.69	9.70	49.39	56.00	-6.61	QP
10	2.8860	34.33	9.70	44.03	46.00	-1.97	AVG
11	4.7892	36.61	9.73	46.34	56.00	-9.66	QP
12	4.7892	27.32	9.73	37.05	46.00	-8.95	AVG

- Note: 1. Result = Reading +Correct Factor.  
 2. If QP Result complies with AV limit, AV Result is deemed to comply with AV limit.  
 3. Test setup: RBW: 200 Hz (9 kHz—150 kHz), 9 kHz (150 kHz—30 MHz).  
 4. Step size: 80Hz (0.009MHz-0.15MHz), 4 kHz (0.15MHz-30MHz), Scan time: auto.

**LINE L RESULTS (LOW CHANNEL, WORST-CASE CONFIGURATION)**

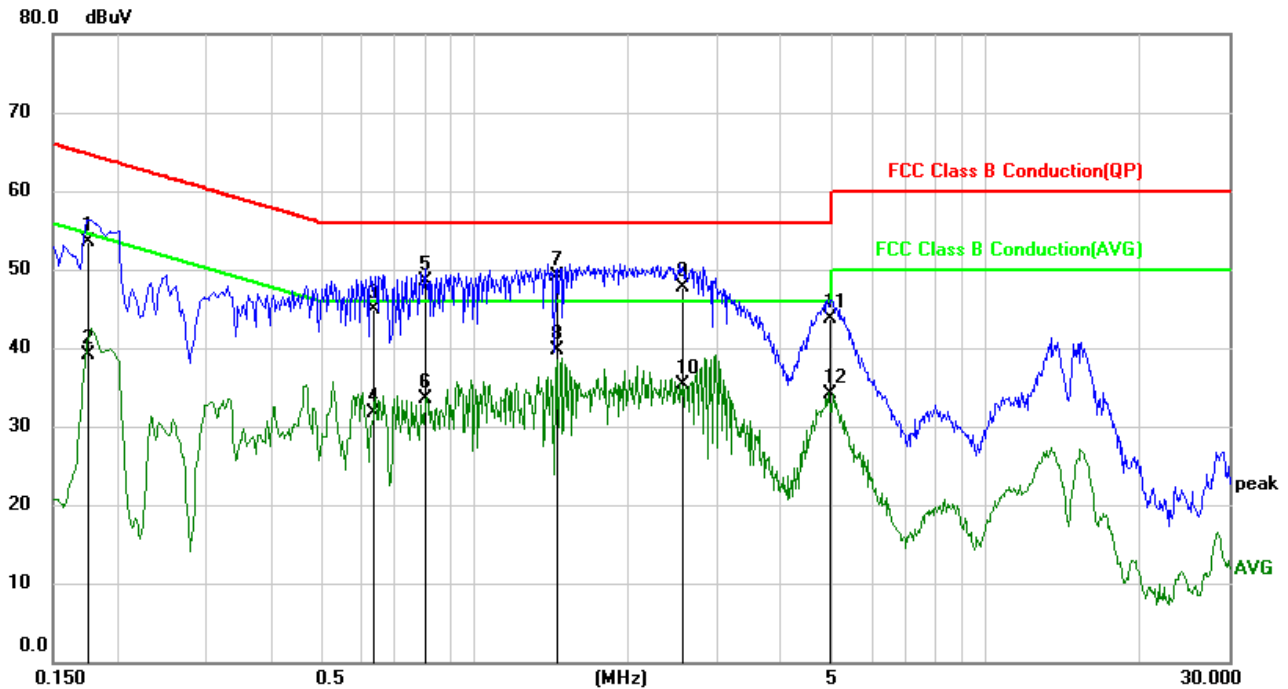

No.	Frequency (MHz)	Reading (dBuV)	Correct (dB)	Result (dBuV)	Limit (dBuV)	Margin (dB)	Remark
1	0.1749	43.87	9.64	53.51	64.72	-11.21	QP
2	0.1749	29.56	9.64	39.20	54.72	-15.52	AVG
3	0.6374	35.20	9.66	44.86	56.00	-11.14	QP
4	0.6374	22.05	9.66	31.71	46.00	-14.29	AVG
5	0.8028	38.77	9.67	48.44	56.00	-7.56	QP
6	0.8028	23.88	9.67	33.55	46.00	-12.45	AVG
7	1.4496	39.35	9.68	49.03	56.00	-6.97	QP
8	1.4496	30.12	9.68	39.80	46.00	-6.20	AVG
9	2.5517	38.05	9.69	47.74	56.00	-8.26	QP
10	2.5517	25.53	9.69	35.22	46.00	-10.78	AVG
11	4.9860	33.92	9.73	43.65	56.00	-12.35	QP
12	4.9860	24.41	9.73	34.14	46.00	-11.86	AVG

- Note: 1. Result = Reading +Correct Factor.  
 2. If QP Result complies with AV limit, AV Result is deemed to comply with AV limit.  
 3. Test setup: RBW: 200 Hz (9 kHz—150 kHz), 9 kHz (150 kHz—30 MHz).  
 4. Step size: 80Hz (0.009MHz-0.15MHz), 4 kHz (0.15MHz-30MHz), Scan time: auto.

Note: All the channels had been tested, but only the worst data recorded in the report.

## 10. ANTENNA REQUIREMENTS

### Applicable requirements

Please refer to FCC §15.203

An intentional radiator shall be designed to ensure that no antenna other than that furnished by the responsible party shall be used with the device. The use of a permanently attached antenna or of an antenna that uses a unique coupling to the intentional radiator shall be considered sufficient to comply with the provisions of this section. The manufacturer may design the unit so that a broken antenna can be replaced by the user, but the use of a standard antenna jack or electrical connector is prohibited.

Please refer to FCC §15.247(b)(4)

The conducted output power limit specified in paragraph (b) of this section is based on the use of antennas with directional gains that do not exceed 6 dBi. Except as shown in paragraph (c) of this section, if transmitting antennas of directional gain greater than 6 dBi are used, the conducted output power from the intentional radiator shall be reduced below the stated values in paragraphs (b)(1), (b)(2), and (b)(3) of this section, as appropriate, by the amount in dB that the directional gain of the antenna exceeds 6 dBi.

### Antenna Connector

EUT has an external antenna with antenna connector, it will be installed in a specific environment and users cannot change the antenna.

### Antenna Gain

The antenna gain of EUT is less than 6 dBi.

**END OF REPORT**

Page 56 of 56