



# MEASUREMENT REPORT

## FCC Part 15B

---

**FCC ID:** 2AC23-WC0DR2611

**APPLICANT:** Hui Zhou Gaoshengda Technology Co., LTD

**Application Type:** Certification

**Product:** WIFI Module

**Model No.:** WC0DR2611

**FCC Classification:** FCC Class B Digital Device (JBP)

**FCC Rule Part(s):** FCC Part 15 Subpart B

**Test Procedure(s):** ANSI C63.4: 2014

**Test Date:** June 29 ~ 30, 2016

Reviewed By : Robin Wu  
( Robin Wu )

Approved By : Marlin Chen  
( Marlin Chen )



The test results relate only to the samples tested.

This equipment has been shown to be capable of compliance with the applicable technical standards as indicated in the measurement report and was tested in accordance with the measurement procedures specified in ANSI C63.4-2014. Test results reported herein relate only to the item(s) tested.

The test report shall not be reproduced except in full without the written approval of MRT Technology (Suzhou) Co., Ltd.

---

### Revision History

Report No.	Version	Description	Issue Date
1606RSU00304	Rev. 01	Initial report	06-30-2016

---

# CONTENTS

Description	Page
<b>§2.1033 General Information .....</b>	<b>4</b>
<b>1. INTRODUCTION .....</b>	<b>5</b>
1.1. Scope .....	5
1.2. MRT Test Location .....	5
<b>2. PRODUCT INFORMATION .....</b>	<b>6</b>
2.1. Equipment Description.....	6
2.2. Device Capabilities .....	6
2.3. Test Configuration .....	7
2.4. Test System Details.....	7
2.5. Test Software .....	7
2.6. EMI Suppression Device(s)/Modifications.....	8
2.7. Labeling Requirements.....	8
<b>3. DESCRIPTION OF TEST .....</b>	<b>9</b>
3.1. Evaluation Procedure .....	9
3.2. AC Line Conducted Emissions .....	9
3.3. Radiated Emissions.....	10
<b>4. TEST EQUIPMENT CALIBRATION DATE .....</b>	<b>11</b>
<b>5. MEASUREMENT UNCERTAINTY.....</b>	<b>12</b>
<b>6. TEST RESULT .....</b>	<b>13</b>
6.1. Summary .....	13
6.2. Conducted Emission Measurement .....	14
6.2.1. Test Limit .....	14
6.2.2. Test Setup.....	14
6.2.3. Test Result of Conducted Emissions.....	15
6.3. Radiated Emission Measurement .....	17
6.3.1. Test Limit .....	17
6.3.2. Test Setup.....	17
6.3.3. Test Result of Radiated Emissions.....	19
<b>7. CONCLUSION.....</b>	<b>23</b>

## §2.1033 General Information

<b>Applicant:</b>	Hui Zhou Gaoshengda Technology Co., LTD
<b>Applicant Address:</b>	NO.75 Zhongkai Development Area, Huizhou, Guangdong, China
<b>Manufacturer:</b>	Hui Zhou Gaoshengda Technology Co., LTD
<b>Manufacturer Address:</b>	NO.75 Zhongkai Development Area, Huizhou, Guangdong, China
<b>Test Site:</b>	MRT Technology (Suzhou) Co., Ltd
<b>Test Site Address:</b>	D8 Building, Youxin Industrial Park, No.2 Tian'edang Rd., Wuzhong Economic Development Zone, Suzhou, China
<b>MRT FCC Registration No.:</b>	809388
<b>Model No.:</b>	WC0DR2611
<b>FCC ID:</b>	2AC23-WC0DR2611
<b>Test Device Serial No.:</b>	N/A <input type="checkbox"/> Production <input checked="" type="checkbox"/> Pre-Production <input type="checkbox"/> Engineering
<b>FCC Classification:</b>	FCC Class B Digital Device (JBP)

### Test Facility / Accreditations

Measurements were performed at MRT Laboratory located in Tian'edang Rd., Suzhou, China.

- MRT facility is a FCC registered (MRT Reg. No. 809388) test facility with the site description report on file and has met all the requirements specified in Section 2.948 of the FCC Rules.
- MRT facility is an IC registered (MRT Reg. No. 11384A-1) test laboratory with the site description on file at Industry Canada.
- MRT facility is a VCCI registered (R-4179, G-814, C-4664, T-2206) test laboratory with the site description on file at VCCI Council.
- MRT Lab is accredited to ISO 17025 by the American Association for Laboratory Accreditation (A2LA) under the American Association for Laboratory Accreditation Program (A2LA Cert. No. 3628.01) in EMC, Telecommunications and Radio testing for FCC, Industry Canada, EU and TELEC Rules.



# 1. INTRODUCTION

## 1.1. Scope

Measurement and determination of electromagnetic emissions (EMC) of radio frequency devices including intentional and/or unintentional radiators for compliance with the technical rules and regulations of the Federal Communications Commission and the Industry Canada Certification and Engineering Bureau.

## 1.2. MRT Test Location

The map below shows the location of the MRT LABORATORY, its proximity to the Taihu Lake. These measurement tests were conducted at the MRT Technology (Suzhou) Co., Ltd. Facility located at D8 Building, Youxin Industrial Park, No.2 Tian'edang Rd., Wuzhong Economic Development Zone, Suzhou, China. The detailed description of the measurement facility was found to be in compliance with the requirements of § 2.948 according to ANSI C63.4-2009 on September 30, 2013.



## 2. PRODUCT INFORMATION

### 2.1. Equipment Description

Product Name	WIFI Module
Model No.	WC0DR2611
Frequency Range	<p><b><u>2.4GHz:</u></b>            For 802.11b/g/n-HT20:            2412 ~ 2462 MHz            For 802.11n-HT40:            2422 ~ 2452 MHz</p> <p><b><u>5GHz:</u></b>            For 802.11a/n-HT20:            5180~5240MHz, 5745~5825MHz            For 802.11n-HT40:            5190~5230MHz, 5755~5795MHz            For 802.11ac-VHT80:            5210MHz, 5775MHz</p>
Type of Modulation	802.11b: CCK 802.11a/g/n/ac: OFDM
Antenna Gain	For 2.4GHz: 2.8dBi For 5GHz: 3dBi

### 2.2. Device Capabilities

This device contains the following capabilities:

2.4GHz and 5GHz WIFI Module

### 2.3. Test Configuration

The **WIFI Module FCC ID: 2AC23-WC0DR2611** was tested per the guidance FCC Part 15 Subpart B: 2013 and ANSI C63.4: 2014 was used to reference the appropriate EUT setup for radiated spurious emissions testing and AC line conducted testing.

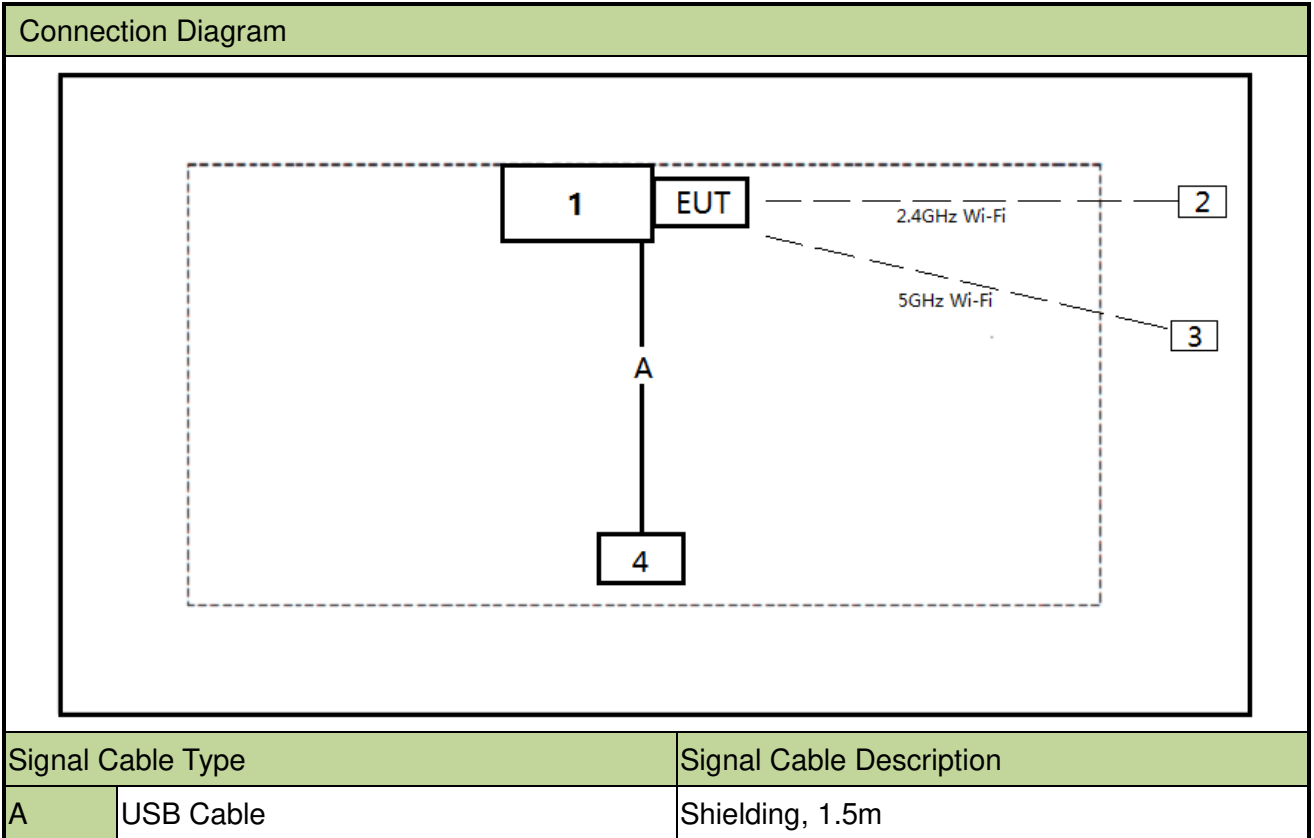

### 2.4. Test System Details

The types for all equipments, plus descriptions of all cables used in the tested system (including inserted cards) are:

Product	Manufacturer	Model No.	Serial No.	Power Cord	
1	Notebook	Lenovo	X201	3626AM3	Non-Shielded, 1.8m
2	Wireless Router	Cisco	CVR100W	CCQ16220BC5	N/A
3	Wireless Router	Apple	A1470	C86P234UP9H6	N/A
4	USB Mouse	Logitech	M-U0026	1451HS05S7C8	N/A

### 2.5. Test Software

Not applicable.

## **2.6. EMI Suppression Device(s)/Modifications**

No EMI suppression device(s) were added and/or no modifications were made during testing.

## **2.7. Labeling Requirements**

Per 2.1074 & 15.19; Docket 95-19

The label shall be permanently affixed at a conspicuous location on the device; instruction manual or pamphlet supplied to the user and be readily visible to the purchaser at the time of purchase.

However, when the device is so small wherein placement of the label with specified statement is not practical, only the FCC ID must be displayed on the device per Section 15.19(a)(5). Please see attachment for FCC ID label and label location.



### 3. DESCRIPTION OF TEST

#### 3.1. Evaluation Procedure

The measurement procedures described in the American National Standard for Methods of Measurement of Radio-Noise Emission from Low-Voltage Electrical Equipment in the Range of 9kHz to 18GHz (ANSI C63.4-2014) was used in the measurement of the **WIFI Module FCC ID: 2AC23-WC0DR2611**.

**Deviation from measurement procedure.....None**

#### 3.2. AC Line Conducted Emissions

The line-conducted facility is located inside an 8'x4'x4' shielded enclosure. A 1m x 2m wooden table 80cm high is placed 40cm away from the vertical wall and 80cm away from the sidewall of the shielded room. Two 10kHz-30MHz, 50Ω/50uH Line-Impedance Stabilization Networks (LISNs) are bonded to the shielded room floor. Power to the LISNs is filtered by external high-current high-insertion loss power line filters. These filters attenuate ambient signal noise from entering the measurement lines. These filters are also bonded to the shielded enclosure.

The EUT is powered from one LISN and the support equipment is powered from the second LISN. If the EUT is a DC-powered device, power will be derived from the source power supply it normally will be powered from and this supply line(s) will be connected to the second LISN. All interconnecting cables more than 1 meter were shortened to a 1 meter length by non-inductive bundling (serpentine fashion) and draped over the back edge of the test table. All cables were at least 40cm above the horizontal reference ground-plane. Power cables for support equipment were routed down to the second LISN while ensuring that that cables were not draped over the second LISN.

Sufficient time for the EUT, support equipment, and test equipment was allowed in order for them to warm up to their normal operating condition. The RF output of the LISN was connected to the receiver and exploratory measurements were made to determine the frequencies producing the maximum emission from the EUT. The receiver was scanned from 150 kHz to 30 MHz. The detector function was set to peak mode for exploratory measurements while the bandwidth of the analyzer was set to 9 kHz. The EUT, support equipment, and interconnecting cables were arranged and manipulated to maximize each emission. Each emission was also maximized by varying: power lines, the mode of operation or resolution, clock or data exchange speed, scrolling H pattern to the EUT and/or support equipment whichever determined the worst-case emission. Once the worst case emissions have been identified, the one EUT cable configuration/arrangement and mode of operation that produced these emissions are used for final measurements on the same test site. Line conducted emissions test results are shown in Section 6.2.

### 3.3. Radiated Emissions

The radiated test facilities consisted of an indoor 3 meter semi-anechoic chamber used for final measurements and exploratory measurements, when necessary. The measurement area is contained within the semi-anechoic chamber which is shielded from any ambient interference. For measurements above 1GHz absorbers are arranged on the floor between the turn table and the antenna mast in such a way so as to maximize the reduction of reflections. For measurements below 1GHz, the absorbers are removed. An MF Model 210SS turntable is used for radiated measurement. It is a continuously rotatable, remote controlled, metallic turntable and 2 meters (6.56 ft.) in diameter. The turn table is flush with the raised floor of the chamber in order to maintain its function as a ground plane. An 80cm high PVC support structure is placed on top of the turntable.

For all measurements, the spectrum was scanned through all EUT azimuths and from 1 to 4 meter receive antenna height using a broadband antenna from 30 MHz up to the upper frequency shown in 15.33(b)(1) depending on the highest frequency generated or used in the device or on which the device operates or tunes. For frequencies above 1GHz, linearly polarized double ridge horn antennas were used. For frequencies below 30 MHz, a calibrated loop antenna was used. When exploratory measurements were necessary, they were performed at 1 meter test distance inside the semi-anechoic chamber using broadband antennas, broadband amplifiers, and spectrum analyzers to determine the frequencies and modes producing the maximum emissions. Sufficient time for the EUT, support equipment, and test equipment was allowed in order for them to warm up to their normal operating condition. The test set-up was placed on top of the 0.8 meter high, 1 x 1.5 meter table. The EUT, support equipment, and interconnecting cables were arranged and manipulated to maximize each emission. Appropriate precaution was taken to ensure that all emissions from the EUT were maximized and investigated. The system configuration, mode of operation, if applicable, turntable azimuth, and receive antenna height was noted for each frequency found.

Final measurements were made in the semi-anechoic chamber using calibrated, linearly polarized broadband and horn antennas. The test setup was configured to the setup that produced the worst case emissions. The spectrum analyzer was set to investigate all frequencies required for testing to compare the highest radiated disturbances with respect to the specified limits. The turntable containing the EUT was rotated through 360 degrees and the height of the receive antenna was varied 1 to 4 meters and stopped at the azimuth and height producing the maximum emission. Each emission was maximized by changing the orientation of the EUT through three orthogonal planes and changing the polarity of the receive antenna, whichever produced the worst-case emissions. According to 3dB beam-width of horn antenna, the horn antenna should be always directed to the EUT when rising height.

#### 4. TEST EQUIPMENT CALIBRATION DATE

##### Conducted Emissions - SR2

Instrument	Manufacturer	Type No.	Asset No.	Cali. Interval	Cali. Due Date
EMI Test Receiver	R&S	ESR7	MRTSUE06001	1 year	2016/11/03
Two-Line V-Network	R&S	ENV216	MRTSUE06002	1 year	2016/11/03
Two-Line V-Network	R&S	ENV216	MRTSUE06003	1 year	2016/11/03
Temperature/Humidity Meter	Ouleinuo	N/A	MRTSUE06114	1 year	2016/11/20

##### Radiated Emissions - AC1

Instrument	Manufacturer	Type No.	Asset No.	Cali. Interval	Cali. Due Date
Spectrum Analyzer	Agilent	N9020A	MRTSUE06106	1 year	2017/05/07
EMI Test Receiver	R&S	ESR7	MRTSUE06001	1 year	2016/11/03
Microwave System Amplifier	Agilent	83017A	MRTSUE06076	1 year	2017/03/28
TRILOG Antenna	Schwarzbeck	VULB9168	MRTSUE06172	1 year	2016/12/11
Broad-Band Horn Antenna	Schwarzbeck	BBHA9120D	MRTSUE06023	1 year	2016/11/07
Temperature/Humidity Meter	Ouleinuo	N/A	MRTSUE06115	1 year	2016/11/20

Software	Version	Function
e3	V8.3.5	EMI Test Software

## 5. MEASUREMENT UNCERTAINTY

Where relevant, the following test uncertainty levels have been estimated for tests performed on the EUT as specified in CISPR 16-4-2. This uncertainty represents an expanded uncertainty expressed at approximately the 95% confidence level using a coverage factor of  $k = 2$ .

<b>AC Conducted Emission Measurement - SR2</b>
Measuring Uncertainty for a Level of Confidence of 95% ( $U=2Uc(y)$ ): 150kHz~30MHz: 3.5 dB
<b>Radiated Emission Measurement - AC1</b>
Measuring Uncertainty for a Level of Confidence of 95% ( $U=2Uc(y)$ ): Horizontal: 30MHz~1GHz: 4.07 dB 1GHz~18GHz: 4.16 dB Vertical:    30MHz~1GHz: 4.18 dB 1GHz~18GHz: 4.76 dB

## 6. TEST RESULT

### 6.1. Summary

**Product Name:** WIFI Module  
**FCC ID:** 2AC23-WC0DR2611  
**FCC Classification:** FCC Class B Digital Device (JBP)  
**Test Mode:** Mode 1: Communication with Wireless Router

FCC Part Section(s)	Test Description	Test Result
15.107	Conducted Emissions	Pass
15.109	Radiated Emissions	Pass

## 6.2. Conducted Emission Measurement

### 6.2.1. Test Limit

FCC Part 15.107 Limits		
Frequency (MHz)	QP (dB $\mu$ V)	AV (dB $\mu$ V)
0.15 - 0.50	66 - 56	56 - 46
0.50 - 5.0	56	46
5.0 - 30	60	50

Note 1: The lower limit shall apply at the transition frequencies.

Note 2: The limit decreases linearly with the logarithm of the frequency in the range 0.15MHz to 0.5MHz.

### 6.2.2. Test Setup

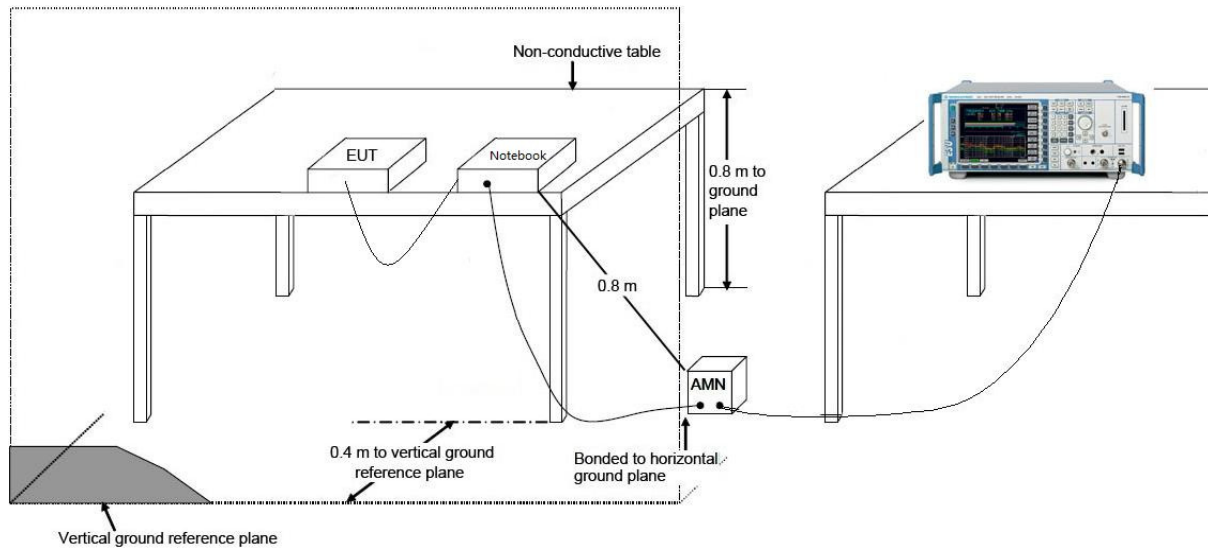

### 6.2.3. Test Result of Conducted Emissions

Site: SR2	Time: 2016/06/30 - 09:47
Limit: FCC_Part15.107_CE_AC Power	Engineer: Roy Cheng
Probe: ENV216_101683_Filter On	Polarity: Line
EUT: WIFI Module	Power: AC 120V/60Hz
Note: Mode 1	

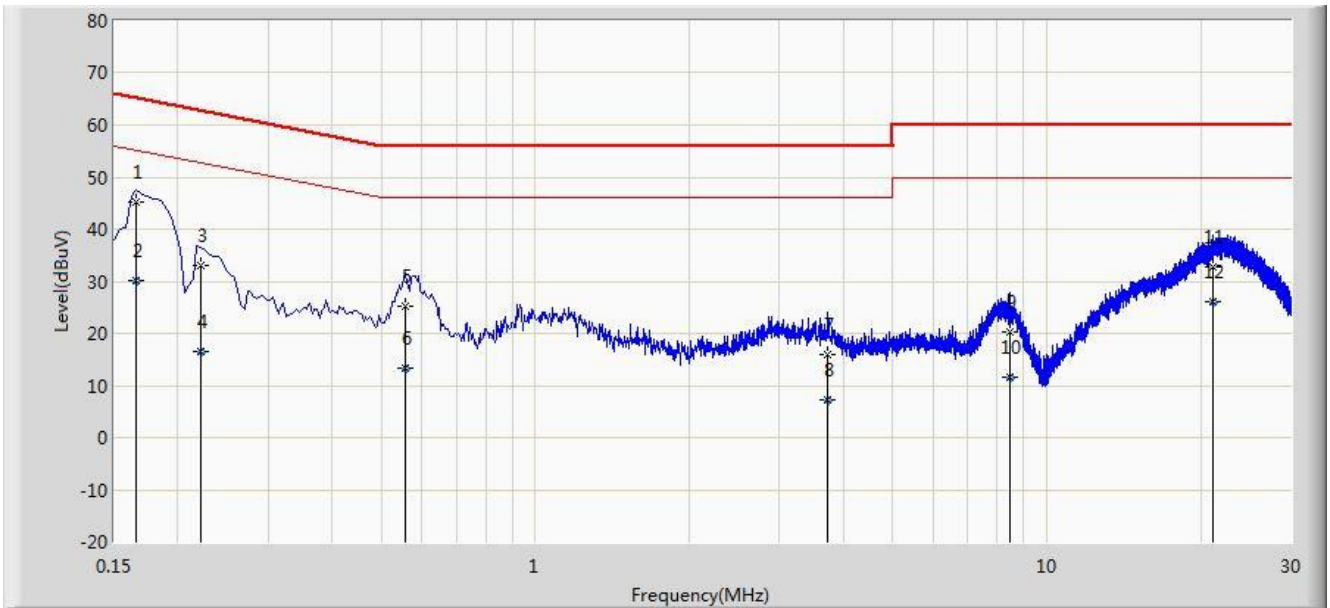

No	Flag	Mark	Frequency (MHz)	Measure Level (dBuV)	Reading Level (dBuV)	Over Limit (dB)	Limit (dBuV)	Factor (dB)	Type
1		*	0.166	45.235	35.148	-19.923	65.158	10.087	QP
2			0.166	30.288	20.201	-24.870	55.158	10.087	AV
3			0.222	32.954	23.014	-29.789	62.744	9.941	QP
4			0.222	16.441	6.500	-36.303	52.744	9.941	AV
5			0.558	25.131	14.994	-30.869	56.000	10.137	QP
6			0.558	13.436	3.299	-32.564	46.000	10.137	AV
7			3.730	16.006	6.054	-39.994	56.000	9.952	QP
8			3.730	7.324	-2.628	-38.676	46.000	9.952	AV
9			8.482	20.150	9.971	-39.850	60.000	10.179	QP
10			8.482	11.498	1.319	-38.502	50.000	10.179	AV
11			21.154	32.624	22.482	-27.376	60.000	10.142	QP
12			21.154	26.114	15.972	-23.886	50.000	10.142	AV

Note: Measure Level (dBuV) = Reading Level (dBuV) + Factor (dB)

Factor (dB) = Cable Loss (dB) + LISN Factor (dB)

Site: SR2	Time: 2016/06/30 - 09:53
Limit: FCC_Part15.107_CE_AC Power	Engineer: Roy Cheng
Probe: ENV216_101683_Filter On	Polarity: Neutral
EUT: WIFI Module	Power: AC 120V/60Hz
Note: Mode 1	

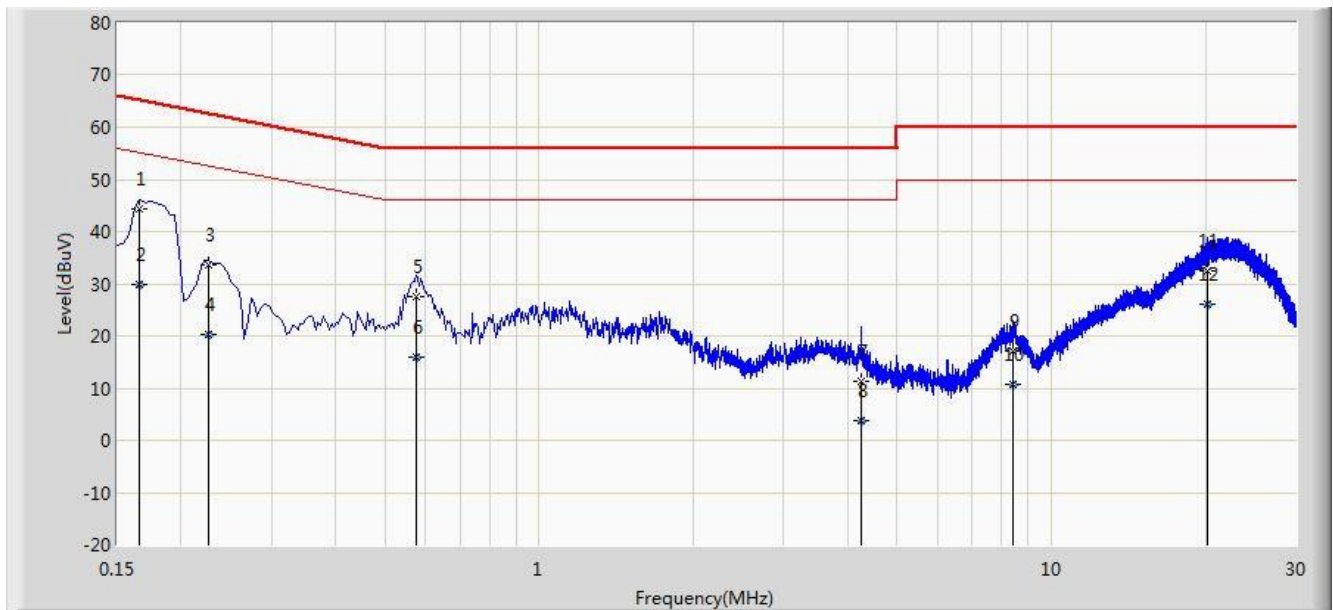

No	Flag	Mark	Frequency (MHz)	Measure Level (dBuV)	Reading Level (dBuV)	Over Limit (dB)	Limit (dBuV)	Factor (dB)	Type
1		*	0.166	44.450	34.379	-20.708	65.158	10.071	QP
2			0.166	29.934	19.863	-25.224	55.158	10.071	AV
3			0.226	33.713	23.731	-28.882	62.595	9.982	QP
4			0.226	20.284	10.302	-32.311	52.595	9.982	AV
5			0.574	27.569	17.424	-28.431	56.000	10.145	QP
6			0.574	15.926	5.780	-30.074	46.000	10.145	AV
7			4.258	11.207	1.222	-44.793	56.000	9.985	QP
8			4.258	3.755	-6.230	-42.245	46.000	9.985	AV
9			8.398	16.980	6.792	-43.020	60.000	10.187	QP
10			8.398	10.664	0.477	-39.336	50.000	10.187	AV
11			20.214	32.323	22.151	-27.677	60.000	10.172	QP
12			20.214	26.105	15.933	-23.895	50.000	10.172	AV

Note: Measure Level (dBμV) = Reading Level (dBμV) + Factor (dB)

Factor (dB) = Cable Loss (dB) + LISN Factor (dB)



### 6.3. Radiated Emission Measurement

#### 6.3.1. Test Limit

FCC Part 15.109 Limits		
Frequency (MHz)	Distance (m)	Level (dB $\mu$ V/m)
30 - 88	3	40
88 - 216	3	43.5
216 - 960	3	46
Above 960	3	54

Note 1: The lower limit shall apply at the transition frequency.

Note 2: Distance refers to the distance in meters between the measuring instrument antenna and the closed point of any part of the device or system.

Note 3: E field strength (dB $\mu$ V/m) = 20 log E field strength (uV/m)

#### 6.3.2. Test Setup

30MHz ~ 1GHz Test Setup:

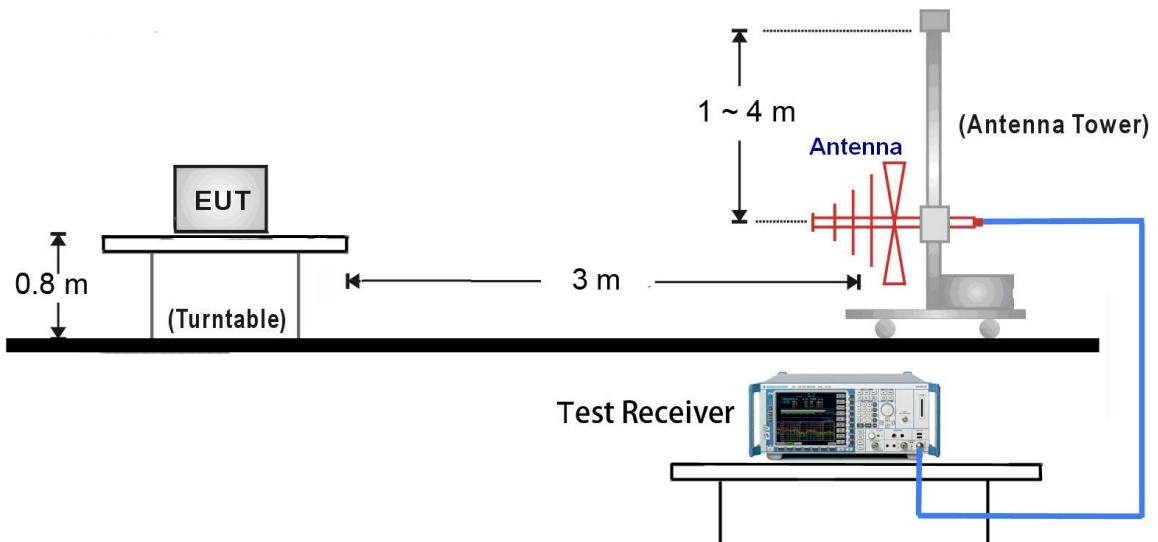

1GHz ~18GHz Test Setup:

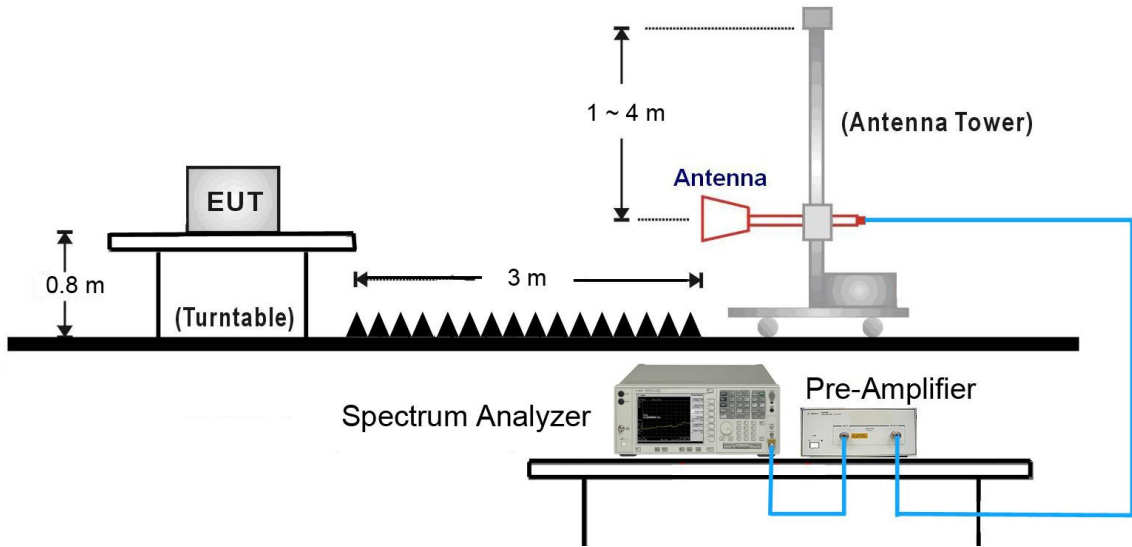

### 6.3.3. Test Result of Radiated Emissions

Site: AC2	Time: 2016/06/30 - 11:18
Limit: FCC_Part15.109_RE(3m)_Class B	Engineer: Lewis Huang
Probe: VULB 9168 _20-2000MHz	Polarity: Horizontal
EUT: WIFI Module	Power: AC 120V/60Hz
Note: Mode 1	

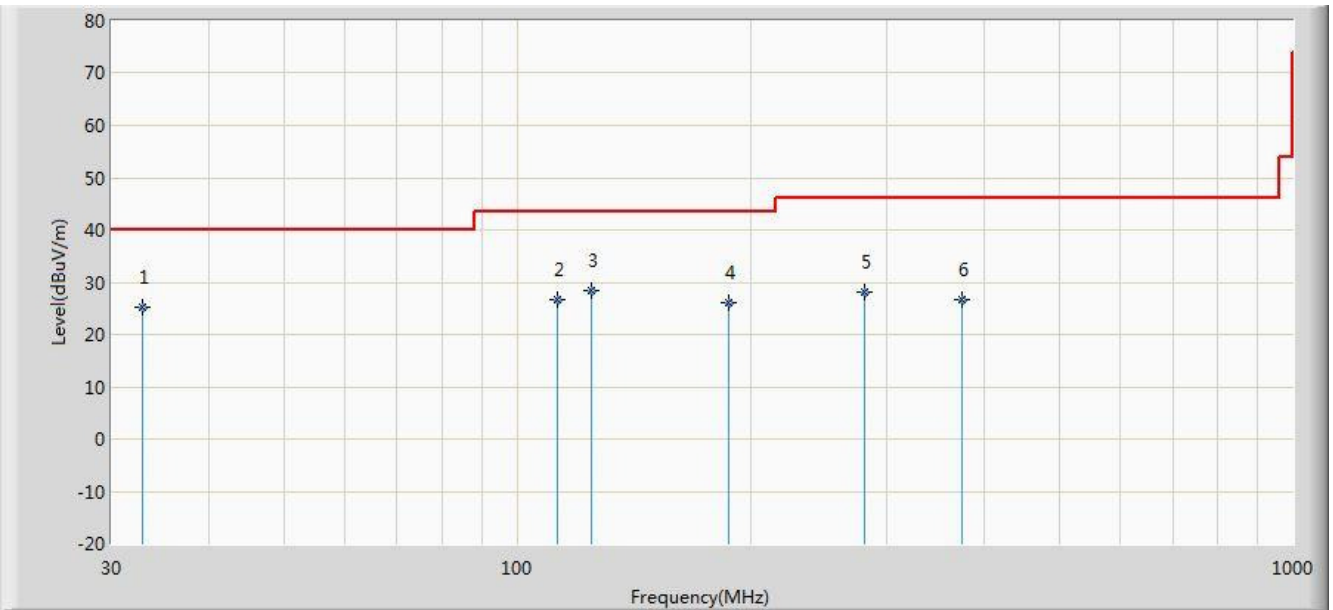

No	Flag	Mark	Frequency (MHz)	Measure Level (dBuV/m)	Reading Level (dBuV)	Over Limit (dB)	Limit (dBuV/m)	Factor (dB)	Ant Pos (cm)	Table Pos (deg)	Type
1		*	32.910	25.102	11.375	-14.898	40.000	13.727	167	251	QP
2			112.935	26.532	14.209	-16.968	43.500	12.323	183	78	QP
3			124.575	28.405	14.983	-15.095	43.500	13.422	177	107	QP
4			187.625	26.109	14.198	-17.391	43.500	11.910	185	311	QP
5			280.745	28.198	14.364	-17.802	46.000	13.834	193	184	QP
6			375.320	26.801	10.792	-19.199	46.000	16.009	184	163	QP

Note: Mode 1 Measure Level (dBuV/m) = Reading Level (dBuV) + Factor (dB)

Factor (dB) = Cable Loss (dB) + Antenna Factor (dB/m).

Site: AC2	Time: 2016/06/30 - 11:18
Limit: FCC_Part15.109_RE(3m)_Class B	Engineer: Lewis Huang
Probe: VULB 9168 _20-2000MHz	Polarity: Vertical
EUT: WIFI Module	Power: AC 120V/60Hz
Note: Mode 1	

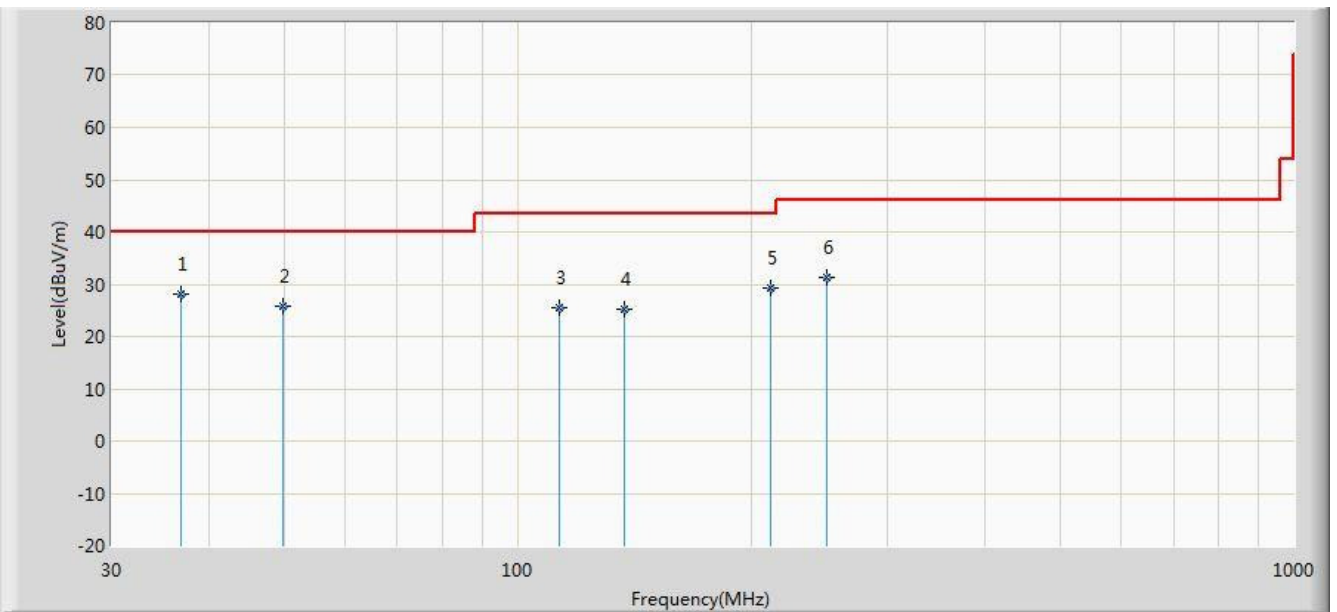

No	Flag	Mark	Frequency (MHz)	Measure Level (dBuV/m)	Reading Level (dBuV)	Over Limit (dB)	Limit (dBuV/m)	Factor (dB)	Ant Pos (cm)	Table Pos (deg)	Type
1		*	36.790	28.236	14.155	-11.764	40.000	14.081	174	29	QP
2			49.885	25.708	11.643	-14.292	40.000	14.065	185	73	QP
3			113.420	25.454	13.082	-18.046	43.500	12.372	158	173	QP
4			137.185	25.113	10.853	-18.387	43.500	14.260	173	206	QP
5			211.875	29.268	17.855	-14.232	43.500	11.414	168	219	QP
6			250.190	31.414	18.478	-14.586	46.000	12.936	171	91	QP

Note: Mode 1 Measure Level (dBuV/m) = Reading Level (dBuV) + Factor (dB)

Factor (dB) = Cable Loss (dB) + Antenna Factor (dB/m).

Site: AC2	Time: 2016/06/30 - 11:12
Limit: FCC_Part15.109_RE(3m)_Class B	Engineer: Lewis Huang
Probe: BBHA9120D_1-18GHz	Polarity: Horizontal
EUT: WIFI Module	Power: AC 120V/60Hz
Note: Mode1	

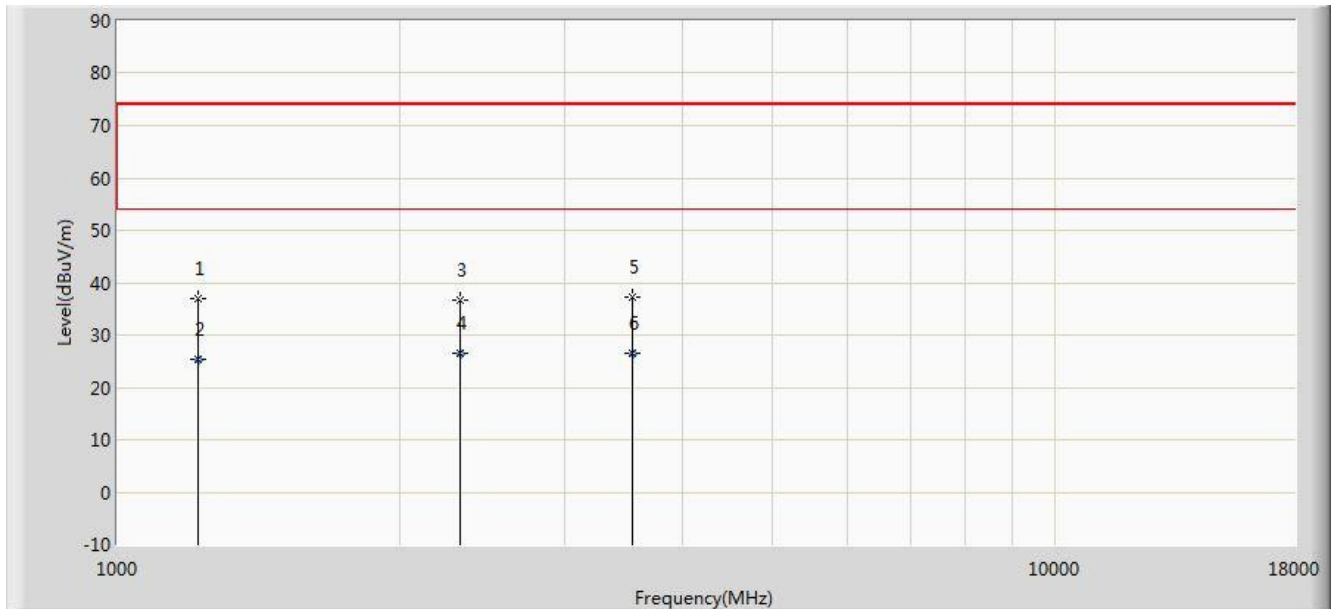

No	Flag	Mark	Frequency (MHz)	Measure Level (dBuV/m)	Reading Level (dBuV)	Over Limit (dB)	Limit (dBuV/m)	Factor (dB)	Ant Pos (cm)	Table Pos (deg)	Type
1			1221.000	36.878	45.803	-37.122	74.000	-8.925	157	176	PK
2			1221.182	25.476	34.398	-28.524	54.000	-8.922	163	143	AV
3			2317.500	36.667	40.203	-37.333	74.000	-3.537	173	139	PK
4		*	2317.523	26.646	30.182	-27.354	54.000	-3.537	142	58	AV
5			3541.500	37.198	38.126	-36.802	74.000	-0.927	168	326	PK
6			3541.653	26.437	27.364	-27.563	54.000	-0.927	172	96	AV

Note: Mode 1 Measure Level (dBuV/m) = Reading Level (dBuV) + Factor (dB)

Factor (dB) = Cable Loss (dB) + Antenna Factor (dB/m) - Pre\_Amplifier Gain (dB).

Site: AC2	Time: 2016/06/30 - 11:12
Limit: FCC_Part15.109_RE(3m)_Class B	Engineer: Lewis Huang
Probe: BBHA9120D_1-18GHz	Polarity: Vertical
EUT: WIFI Module	Power: AC 120V/60Hz
Note: Mode1	

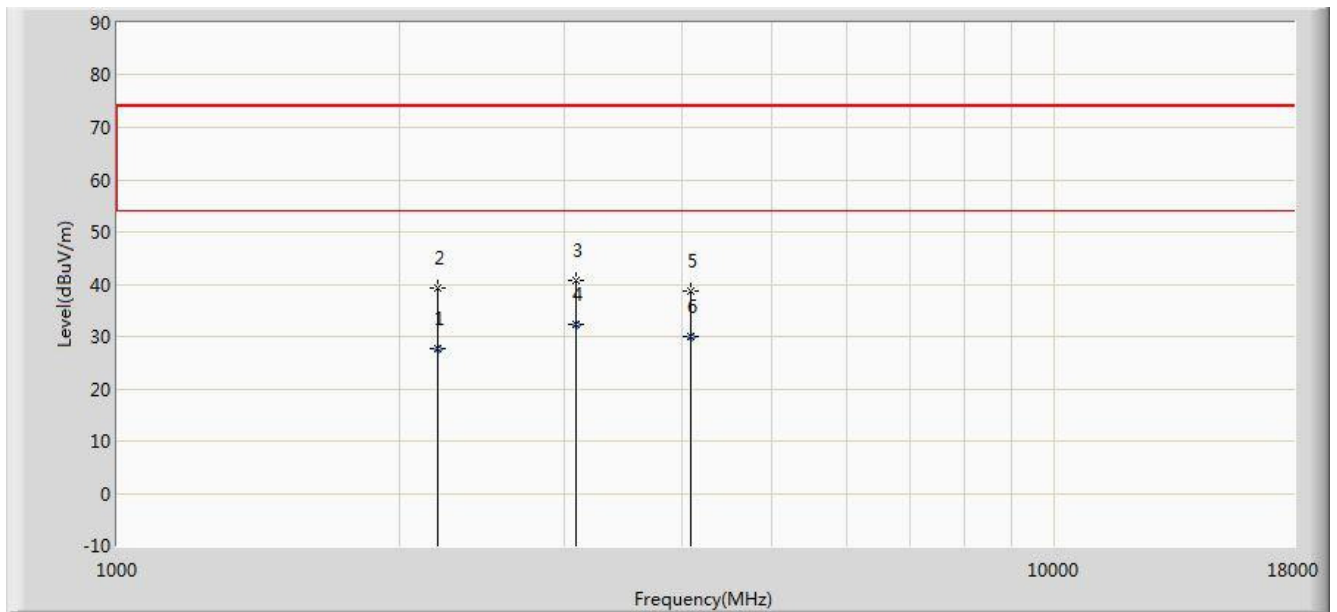

No	Flag	Mark	Frequency (MHz)	Measure Level (dBuV/m)	Reading Level (dBuV)	Over Limit (dB)	Limit (dBuV/m)	Factor (dB)	Ant Pos (cm)	Table Pos (deg)	Type
1			2198.384	27.650	31.283	-26.350	54.000	-3.633	156	24	AV
2			2198.500	39.290	42.922	-34.710	74.000	-3.633	148	235	PK
3			3082.500	40.756	42.608	-33.244	74.000	-1.852	162	105	PK
4		*	3082.637	32.422	34.273	-21.578	54.000	-1.851	159	59	AV
5			4094.000	38.650	38.007	-35.350	74.000	0.643	172	213	PK
6			4094.115	30.018	29.374	-23.982	54.000	0.643	163	306	AV

Note: Mode 1 Measure Level (dBuV/m) = Reading Level (dBuV) + Factor (dB)

Factor (dB) = Cable Loss (dB) + Antenna Factor (dB/m) - Pre\_Amplifier Gain (dB).

## 7. CONCLUSION

The data collected relate only the item(s) tested and show that the **WIFI Module FCC ID: 2AC23-WC0DR2611** has been tested to comply with the requirements specified in §15.107 and §15.109 of the FCC Rules.