

FCC Radio Test Report

FCC ID: 2AC23-W2CM2510

**FCC 47 CFR Part 15 Subpart C
RSS 247 Issue 1:2015**

Product : WIFIModule

Trade Name : GSD

Model Number : W2CM2510

Series Number : W2CM2510P

Firmware Version Identification Number (FVIN): 1.1

Issued for

Hui Zhou Gaoshengda Technology Co.,LTD
NO.75 Zhongkai Development Area,Huizhou,Guangdong, China

Issued by

Shenzhen ATL Testing Technology Co.,Ltd.
F/4, Building 10, Dayuan Industrial Zone, Xili Town, Nanshan District, Shenzhen,
China
Tel.: +86-0755-26909822 Fax.: +86-0755-61605504
Website:www.atllab.org

Note: This report shall not be reproduced except in full, without the written approval of ShenzhenATL Testing Technology Co., Ltd.. This document may be altered or revised by ShenzhenATL Testing Technology Co., Ltd. personnel only, and shall be noted in therevision section of the document. The testresults in the report only apply to the tested sample

Table of Contents	Page
1 . TEST SUMMARY	5
1.1 TEST FACILITY	6
1.2 MEASUREMENT UNCERTAINTY	6
2 . GENERAL INFORMATION	7
2.1 GENERAL DESCRIPTION OF EUT	7
2.2 DESCRIPTION OF TEST MODES	9
2.3 DESCRIPTION OF TEST SETUP	10
2.4 DESCRIPTION TEST PERIPHERAL AND EUT PERIPHERAL	11
2.5 EUT EXERCISE SOFTWARE	11
3 . CONDUCTED EMISSION TEST	12
3.1 CONDUCTED EMISSION MEASUREMENT (Frequency Range 150KHz-30MHz)	12
3.2 TEST PROCEDURE	12
3.3 TEST SETUP	13
3.4 TEST INSTRUMENTS	13
3.5 EUT OPERATING CONDITIONS	13
3.6 TEST RESULTS	14
RADIATED EMISSION MEASUREMENT	18
3.7 RADIATED EMISSION LIMIT (Frequency Range 9KHz-1000MHz)	18
3.8 TEST PROCEDURE	18
3.9 TEST SETUP	19
3.10 TEST INSTRUMENTS	20
3.11 EUT OPERATING CONDITIONS	20
3.12 TEST RESULTS	21
4 . MAXIMUM CONDUCTED OUTPUT POWER MEASUREMENT	35
4.1 LIMITS	35
4.2 TEST PROCEDURE	35
4.3 TEST SETUP	35
4.4 TEST INSTRUMENTS	35
4.5 EUT OPERATING CONDITIONS	35
4.6 TEST RESULTS	35
5 . OCCUPIED BANDWIDTH MEASUREMENT	39
5.1 LIMITS	39
5.2 TEST PROCEDURE	39

Table of Contents	Page
5.3 TEST SETUP	39
5.4 TEST INSTRUMENTS	39
5.5 EUT OPERATING CONDITIONS	39
5.6 TEST RESULTS	39
6 . POWER SPECTRAL DENSITY	56
6.1 LIMITS	56
6.2 TEST PROCEDURE	56
6.3 TEST SETUP	56
6.4 TEST INSTRUMENTS	56
6.5 EUT OPERATING CONDITIONS	56
6.6 TEST RESULTS	56
7 . BAND EDGEANDOUT-OF-BAND EMISSION	73
7.1 LIMITS	73
7.2 TEST PROCEDURE	73
7.3 TEST SETUP	73
7.4 TEST INSTRUMENTS	74
7.5 EUT OPERATING CONDITIONS	74
7.6 TEST RESULTS	74
8 . ANTENNA REQUIREMENT	87
8.1 REQUIREMENT	87
8.2 ANTENNA CONNECTOR CONSTRUCTION	87

1. TEST SUMMARY

Test procedures according to the technical standards:

FCC Part 15 Subpart C (15.247)/RSS 247 Issue 1: 2015				
Standard Section		Test Item	Judgment	Remark
FCC	IC			
15.203	/	Antenna Requirement	PASS	
15.207	RSS-GEN 7.2.4	Conducted Emission	PASS	
15.205/ 15.209	RSS-GEN 7.2.2	Restricted Bands	PASS	
15.247(a)(2)	RSS 247 5.2 (1)	6dB Bandwidth	PASS	
15.247(b)	RSS 247 5.4 (4)	Peak Output Power	PASS	
15.247(e)	RSS 247 5.2 (2)	Power Spectral Density	PASS	
15.247(d)	RSS 247 5.5	Band Edge/Out-of-band Emission	PASS	

NOTE:

(1) "N/A" denotes test is not applicable in this Test Report

(2) The test results of this report relate only to the tested sample(s) identified in this report.

1.1 TEST FACILITY

Shenzhen ATL Testing Technology Co.,Ltd.

Add. : F/4, Building 10, Dayuan Industrial Zone, Xili Town, Nanshan District, Shenzhen, China

1.2 MEASUREMENT UNCERTAINTY

The reported uncertainty of measurement $y \pm U$, where expanded uncertainty U is based on a standard uncertainty multiplied by a coverage factor of $k=2$, providing a level of confidence of approximately **95** %.

A. Conducted Emission :

The measurement uncertainty is evaluated as ± 3.2 dB.

B. Radiated Measurement :

The measurement uncertainty is evaluated as ± 3.7 dB.

2. GENERAL INFORMATION

2.1 GENERAL DESCRIPTION OF EUT

Equipment	WIFI Module
Model Name	W2CM2510
Additional Model Number(s)	W2CM2510
Model Difference	All these models are identical in the same PCB, layout and electrical circuit, the only difference is external port.
Frequency Range	802.11b/g/n(HT20):2412~2462 MHz 802.11n(HT40):2422~2452 MHz
Modulation Type	802.11b: DSSS (DBPSK/DQPSK/CCK) 802.11g: OFDM (BPSK/QPSK/16QAM/64QAM) 802.11n: OFDM (BPSK/QPSK/16QAM/64QAM)
Data Rate	802.11b: 1/2/5.5/11 Mbps 802.11g: 6/9/12/18/24/36/48/54 Mbps 802.11n: 150 Mbps
RF Output Power	802.11b: 17.90 dBm 802.11g: 17.74 dBm 802.11n(HT20): 14.01 dBm 802.11n(HT40): 14.97 dBm
Directional Gain	5.95 dBi(Max.) <i>see the note 2</i>
Antenna Type	PIFA Antenna(Max.: 2.94dBi)
Power Source	DC Powered by host system.
Power Rating	DC 5V from USB interference.
Remark	More details EUT technical specifications, please refer to the User's Manual.

Note:

- (1) This Test Report is FCC Part 15 Subpart C, 15.247 for IEEE 802.11b/g/n. And the Test procedure follows the FCC KDB 558074 D01 DTS Meas Guidance v03r05.
- (2) Transmitting mode with antennas

Mode	TX Antenna (s)	Remark
802.11b	1	The worst case is ANT 1 TX
802.11g	1	The worst case is ANT 1 TX
802.11n(HT20)	2	ANT 1+ANT 2 TX
802.11n(HT40)	2	ANT 1+ANT 2 TX

Antenna	Brand	Model Name	Type	Antenna Gain(dBi)
ANT1	ZTX	ZTX2458001	PIFA	2.94
ANT2	ZTX	ZTX2458001	PIFA	2.94

Note: For MIMO mode: Directional gain=Gain(Ant1)+Gain(Ant1)=5.95 dBi in 2.4G 802.11 n(HT20/HT40) has MIMO mode.

(3) Channel List.

2.4 GHz Band				
Frequency Band	Channel No.	Frequency	Channel No.	Frequency
2400~2483.5MHz	1	2412 MHz	7	2442 MHz
	2	2417 MHz	8	2447 MHz
	3	2422 MHz	9	2452 MHz
	4	2427 MHz	10	2457 MHz
	5	2432 MHz	11	2462 MHz
	6	2437 MHz		

For 802.11b/g/n(HT20), use channel 1~11
 For 802.11n(HT40), use channel 3~9

2.2 DESCRIPTION OF TEST MODES

To investigate the maximum EMI emission characteristics generates from EUT, the test system was pre-scanning tested base on the consideration of following EUT operation mode or test configuration mode which possible have effect on EMI emission level. Each of these EUT operation mode(s) or test configuration mode(s) mentioned above was evaluated respectively.

Pretest Mode	Description
Mode 1	WiFi TX Mode
Mode 2	WiFi TX 802.11b Mode
Mode 3	WiFi TX 802.11g Mode
Mode 4	WiFi TX 802.11n(HT20)Mode
Mode 5	WiFi TX 802.11n(HT40) Mode

For Conducted Test	
Final Test Mode	Description
Mode 2	WiFi TX Mode

For Radiated Test	
Final Test Mode	Description
Mode 1	WiFi TX Mode
Mode 2	WiFi TX 802.11b Mode
Mode 3	WiFi TX 802.11g Mode
Mode 4	WiFi TX 802.11n(HT20)Mode
Mode 5	WiFi TX 802.11n(HT40) Mode

Note:

- (1) Software used to control the EUT for staying in continuous transmitting mode was programmed. After verification, all tests were carried out with the worst case test modes as shown below.
- (2) IEEE 802.11b Mode:
Channel (2412/2437/2462 MHz) with 1Mbps data rate were chosen for full testing.
- (3) IEEE 802.11g Mode:
Channel (2412/2437/2462 MHz) with 6 Mbps data rate were chosen for full testing.
- (4) IEEE 802.11n(HT20) Mode:
Channel (2412/2437/2462 MHz) with MCS 0 data rate were chosen for full testing.
- (5) IEEE 802.11n(HT40) Mode:
Channel (2422/2437/2452 MHz) with MCS 0 data rate were chosen for full testing.
- (6) By preliminary testing and verifying three axis (X, Y and Z) position of EUT transmitted status, it was found that "X axis" position was the worst, then the final test was executed the worst condition and test data were recorded in this report.

2.3 DESCRIPTION OF TEST SETUP

Radiated Emission

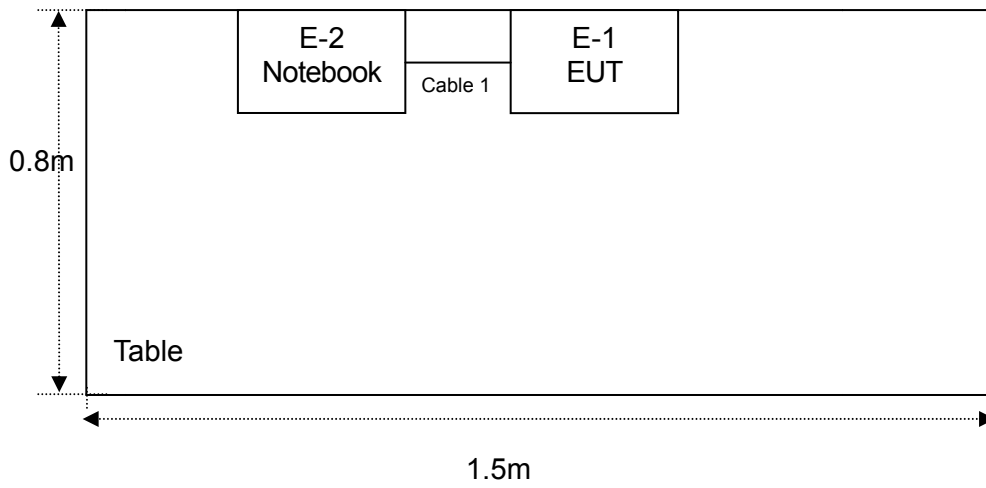

2.4 DESCRIPTION TEST PERIPHERAL AND EUT PERIPHERAL

The EUT has been tested as an independent unit together with other necessary accessories or support units. The following support units or accessories were used to form a representative test configuration during the tests.

Item	Equipment	Mfr/Brand	Model/Type No.	Series No.	Note
E-1	WIFI Module	GSD	W2CM2510	N/A	EUT
E-2	Notebook	LENOVO	P405	DOC	

Item	Shielded Type	Ferrite Core	Length	Note
1	NO	NO	15cm	

Note:

- (1) The support equipment was authorized by Declaration of Confirmation.
- (2) For detachable type I/O cable should be specified the length in cm in 『Length』 column.
- (3) “YES” means “shielded”“with core”; “NO” means “unshielded”“without core”.

2.5 EUT EXERCISE SOFTWARE

Power Parameters for Testing			
Test Software Version	MT7603U.exe		
Mode	Frequency/ Parameters		
802.11b	2412 MHz	2437 MHz	2462 MHz
	DEF	DEF	DEF
802.11g	2412 MHz	2437 MHz	2462 MHz
	DEF	DEF	DEF
802.11n(HT20)	2412 MHz	2437 MHz	2462 MHz
	DEF	DEF	DEF
802.11n(HT40)	2422 MHz	2437 MHz	2452 MHz
	DEF	DEF	DEF

3.CONDUCTEDEMISSION TEST

3.1CONDUCTED EMISSIONMEASUREMENT(Frequency Range 150KHz-30MHz)

FREQUENCY (MHz)	Quasi-peak	Average
	dBuV	dBuV
0.15 -0.5	66 - 56 *	56 - 46 *
0.50 -5.0	56.00	46.00
5.0 -30.0	60.00	50.00

Note:

- (1) The tighter limit applies at the band edges.
- (2) The limit of " * " marked band means the limitation decreases linearly with the logarithm of the frequency in the range.

The following table is the setting of the receiver

Receiver Parameters	Setting
Attenuation	10 dB
Start Frequency	0.15 MHz
Stop Frequency	30 MHz
IF Bandwidth	9 kHz

3.2TEST PROCEDURE

- a. The EUT was placed 0.8 meters from the horizontal ground plane with EUT being connected to the power mains through a line impedance stabilization network (LISN). All other support equipments powered from additional LISN(s). The LISN provide 50 Ohm/ 50uH of coupling impedance for the measuring instrument.
- b. Interconnecting cables that hang closer than 40 cm to the ground plane shall be folded back and forth in the center forming a bundle 30 to 40 cm long.
- c. I/O cables that are not connected to a peripheral shall be bundled in the center. The end of the cable may be terminated, if required, using the correct terminating impedance. The overall length shall not exceed 1 m.
- d. LISN at least 80 cm from nearest part of EUT chassis.
- e. For the actual test configuration, please refer to the related Item –EUT Test Photos.

3.3 TEST SETUP

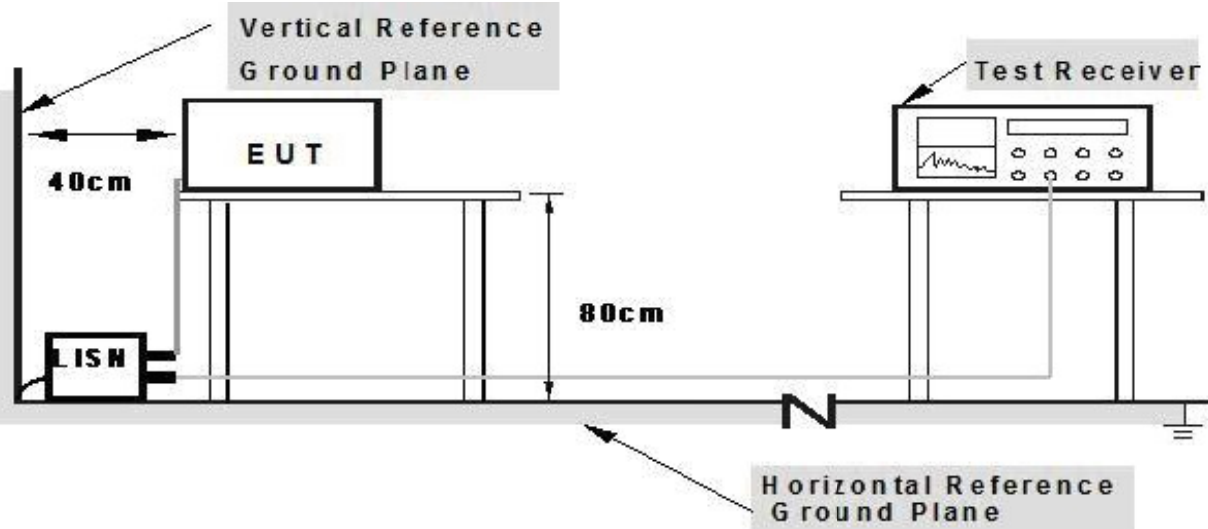

- Note: 1. Support units were connected to second LISN.**
2. Both of LISNs (AMN) are 80 cm from EUT and at least 80 from other units and other metal planes

3.4 TEST INSTRUMENTS

Equipment	Manufacturer	Type No.	Serial No.	Last calibration	Calibrated until	Calibration period
LISN	R&S	NSLK81	8126466	Jul. 04, 2016	Jul. 03. 2017	1 year
LISN	R&S	NSLK81	8126487	Jul. 04, 2016	Jul. 03. 2017	1 year
50Ω Switch	ANRITSU CORP	MP59B	6200983704	Jul. 04, 2016	Jul. 03. 2017	1 year
Test Cable	N/A	C01	N/A	Jul. 04, 2016	Jul. 03. 2017	1 year
Test Cable	N/A	C02	N/A	Jul. 04, 2016	Jul. 03. 2017	1 year
Test Cable	N/A	C03	N/A	Jul. 04, 2016	Jul. 03. 2017	1 year
EMI Test Receiver	R&S	ESCI	1166.595	Jul. 04, 2016	Jul. 03. 2017	1 year
Passive Voltage Probe	ESH2-Z3	R&S	100196	Jul. 04, 2016	Jul. 03. 2017	1 year

3.5 EUT OPERATING CONDITIONS

The EUT tested system was configured as the statements of 2.3 Unless otherwise a special operating condition is specified in the follows during the testing.

3.6 TEST RESULTS

EUT :	WIFI Module	Model Name. :	W2CM2510
Temperature :	26°C	Relative Humidity :	56%
Pressure :	1010hPa	Terminal:	Line
Test Mode :	WIFI TX Mode (B 2412MHz)		
Test Voltage :	120V/ 60Hz		

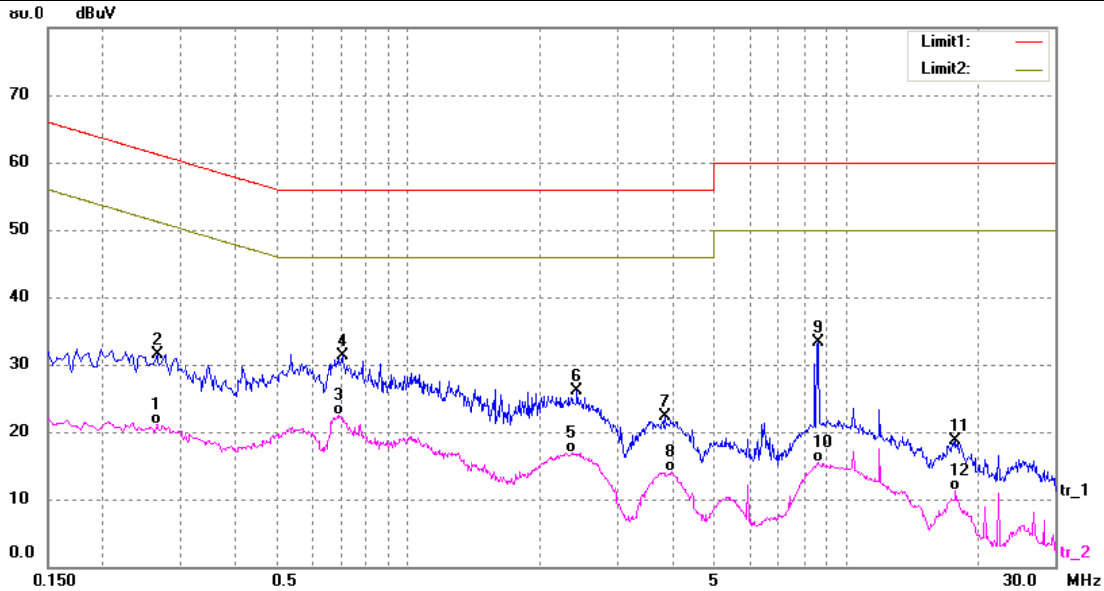

No.	Frequency (MHz)	Reading (dBuV)	Correct (dB/m)	Result (dBuV)	Limit (dBuV)	Margin (dB)	Detector
1	0.2660	25.75	5.80	31.55	61.24	-29.69	QP
2	0.2340	15.57	5.80	21.37	52.31	-30.94	AVG
3*	0.7060	25.45	5.78	31.23	56.00	-24.77	QP
4	0.7060	16.73	5.78	22.51	46.00	-23.49	AVG
5	2.4260	20.42	5.72	26.14	56.00	-29.86	QP
6	2.4260	11.18	5.73	16.91	46.00	-29.09	AVG
7	3.9900	16.58	5.69	22.27	56.00	-33.73	QP
8	3.9900	8.46	5.69	14.15	46.00	-31.85	AVG
9	8.5940	27.81	5.56	33.37	60.00	-26.63	QP
10	8.5940	9.86	5.56	15.42	50.00	-34.58	AVG
11	17.8100	13.06	5.65	18.71	60.00	-41.29	QP
12	17.8100	5.59	5.65	11.24	50.00	-38.76	AVG

Remark:

1. All readings are Quasi-Peak and Average values.
2. Factor = Insertion Loss + Cable Loss.

EUT :	WIFI Module	Model Name. :	W2CM2510
Temperature :	26°C	Relative Humidity :	56%
Pressure :	1010hPa	Terminal:	Neutral
Test Mode :	WIFI TX Mode (B 2412MHz)		
Test Voltage :	120V/ 60Hz		

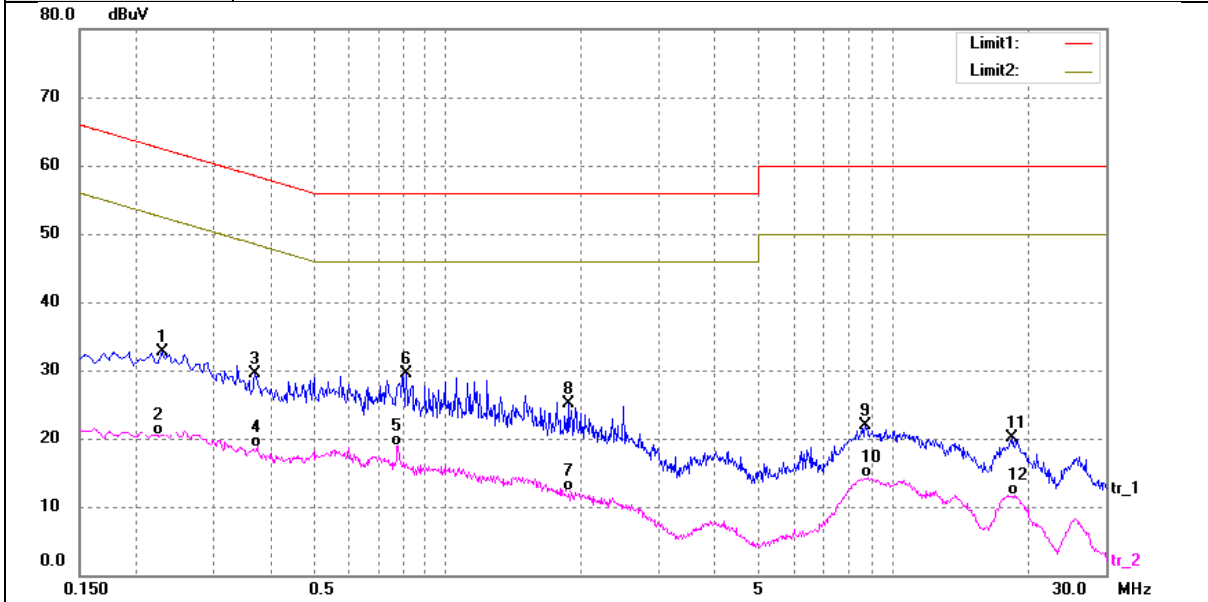

No.	Frequency (MHz)	Reading (dBuV)	Correct (dB/m)	Result (dBuV)	Limit (dBuV)	Margin (dB)	Detector
1	0.2300	26.95	5.80	32.75	62.45	-29.70	QP
2	0.2300	15.27	5.80	21.07	51.89	-30.82	AVG
3	0.3700	23.69	5.80	29.49	58.50	-29.01	QP
4	0.3700	13.00	5.80	18.80	48.41	-29.61	AVG
5	0.8100	23.68	5.78	29.46	56.00	-26.54	QP
6*	0.7740	13.05	5.78	18.83	46.00	-27.17	AVG
7	1.8740	19.35	5.74	25.09	56.00	-30.91	QP
8	1.8740	8.29	5.75	14.04	46.00	-31.96	AVG
9	8.7020	16.25	5.56	21.81	60.00	-38.19	QP
10	8.7020	8.76	5.55	14.31	50.00	-35.69	AVG
11	18.5980	14.39	5.66	20.05	60.00	-39.95	QP
12	18.5980	6.05	5.66	11.71	50.00	-38.29	AVG

Remark:

1. All readings are Quasi-Peak and Average values.
2. Factor = Insertion Loss + Cable Loss.

EUT :	WIFI Module	Model Name. :	W2CM2510
Temperature :	26°C	Relative Humidity :	56%
Pressure :	1010hPa	Terminal:	Line
Test Mode :	WIFI TX Mode (B 2412MHz)		
Test Voltage :	240V/ 60Hz		

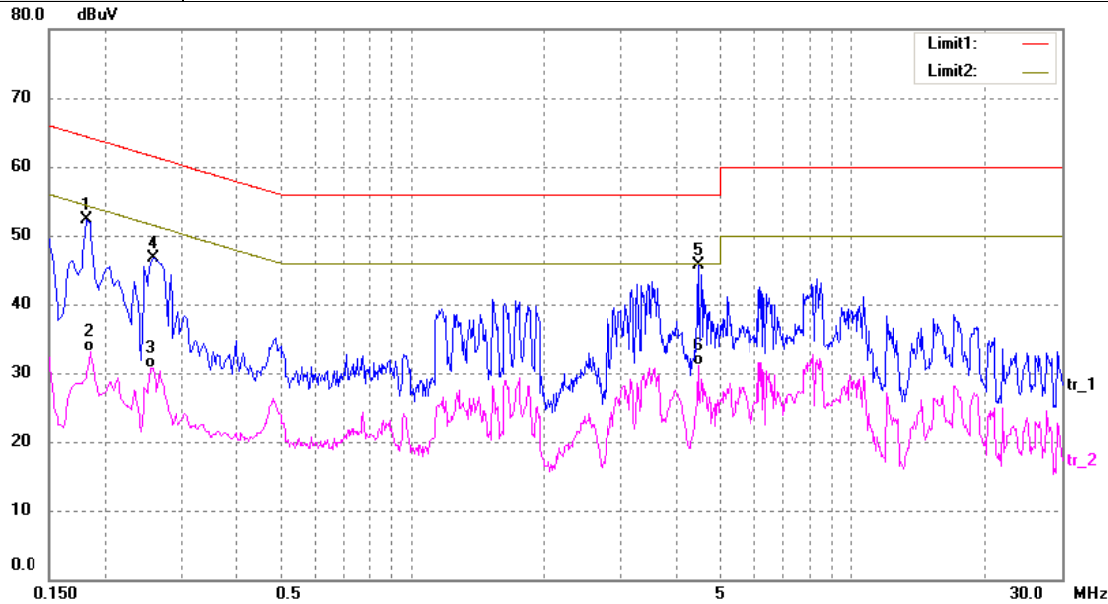

No.	Frequency (MHz)	Reading (dBuV)	Correct (dB/m)	Result (dBuV)	Limit (dBuV)	Margin (dB)	Detector
1	0.1820	46.44	5.82	52.26	64.39	-12.13	QP
2	0.1820	27.33	5.81	33.14	54.21	-21.07	AVG
3	0.2580	40.91	5.80	46.71	61.50	-14.79	QP
4	0.2580	24.96	5.80	30.76	51.63	-20.87	AVG
5*	4.4660	39.96	5.67	45.63	56.00	-10.37	QP
6	4.4660	25.45	5.67	31.12	46.00	-14.88	AVG

Remark:

1. All readings are Quasi-Peak and Average values.
2. Factor = Insertion Loss + Cable Loss.

EUT :	WIFI Module	Model Name. :	W2CM2510
Temperature :	26°C	Relative Humidity :	56%
Pressure :	1010hPa	Terminal:	Neutral
Test Mode :	WIFI TX Mode (B 2412MHz)		
Test Voltage :	240V/ 60Hz		

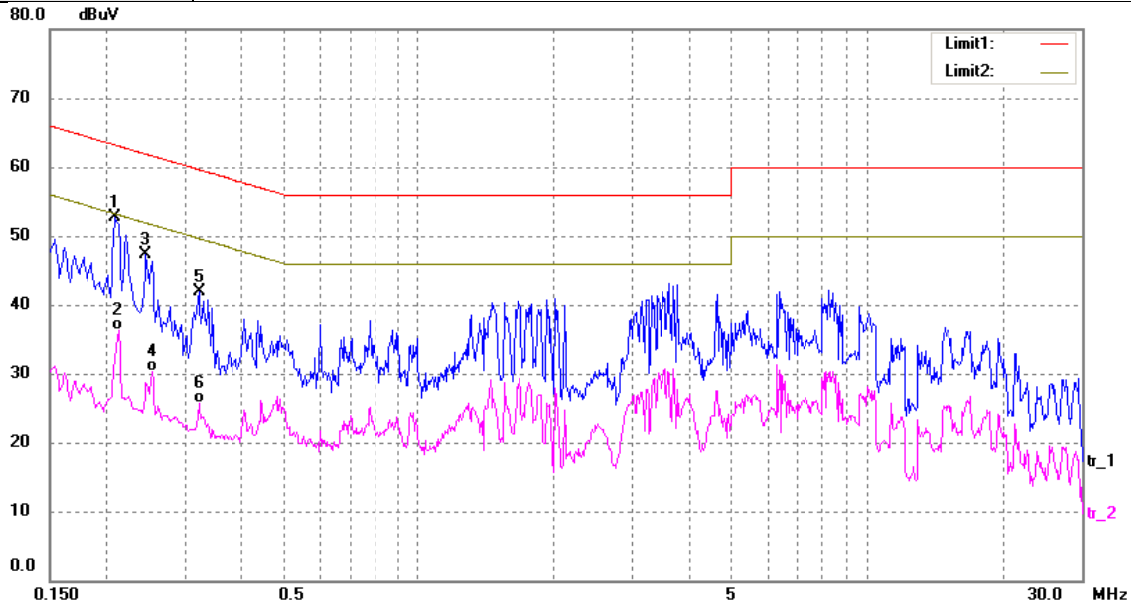

No.	Frequency (MHz)	Reading (dBuV)	Correct (dB/m)	Result (dBuV)	Limit (dBuV)	Margin (dB)	Detector
1*	0.2100	46.83	5.80	52.63	63.21	-10.58	QP
2	0.2100	30.42	5.80	36.22	53.05	-16.83	AVG
3	0.2460	41.41	5.80	47.21	61.89	-14.68	QP
4	0.2460	24.58	5.80	30.38	51.63	-21.25	AVG
5	0.3220	36.17	5.80	41.97	59.66	-17.69	QP
6	0.3220	19.91	5.80	25.71	49.66	-23.95	AVG

Remark:

1. All readings are Quasi-Peak and Average values.
2. Factor = Insertion Loss + Cable Loss.

RADIATED EMISSION MEASUREMENT

3.7 RADIATED EMISSION LIMIT (Frequency Range 9KHz-1000MHz)

20 dBc in any 100 kHz bandwidth outside the operating frequency band. In case the emission fall within the restricted band specified on 15.205(a) and RSS-210 Section 2.2&A8.5, then the 15.209(a) and RSS-General limit in the table below has to be followed.

FREQUENCY (MHz)	Field Strength (uV/m at meter)	Measurement Distance (meters)
0.009 -0.490	2400/F(KHz)	300
0.490 -1.705	24000/F(KHz)	30
1.705 -30.0	30	30
30 -88	100	3
88 -216	150	3
216~960	200	3
Above 960	500	3

RADIATED EMISSION LIMITS (Above 1000MHz)

FREQUENCY (MHz)	Class A (dBuV/m)(at 3 M)		Class B (dBuV/m)(at 3 M)	
	Peak	Average	Peak	Average
Above 1000	80	60	74	54

Note:

- (1) The limit for radiated test was performed according to FCC PART 15C.
- (2) The tighter limit applies at the band edges.
- (2) Emission Level(dBuV/m)=20log Emission Level(uV/m)

The following table is the setting of the receiver

Receiver Parameter	Setting
Attenuation	Auto
Start Frequency~ Stop Frequency	9kHz~150kHz/ RB 200Hz for QP
Start Frequency~ Stop Frequency	150kHz~30MHz/ RB 9kHz for QP
Start Frequency~ Stop Frequency	30MHz~1000MHz/ RB 120kHz for QP

The following table is the setting of the spectrum

Spectrum Parameter	Setting
Attenuation	Auto
Start Frequency	1000 MHz
Stop Frequency	10 th carrier harmonic
RB/ VB (emission in restricted band)	1MHz/ 3 MHz for Peak, 1MHz/ 10Hz for Average

3.8 TEST PROCEDURE

- a. The measuring distance of at 3 m shall be used for measurements at frequency up to 1GHz. For frequencies above 1GHz, any suitable measuring distance may be used.
- b. The EUT was placed on the top of a rotating table 0.8 meters above the ground at a 3 meter open area test site. The table was rotated 360 degrees to determine the position of the highest radiation.

- c. The height of the equipment or of the substitution antenna shall be 0.8 m; the height of the test antenna shall vary between 1 m to 4 m. Both horizontal and vertical polarizations of the antenna are set to make the measurement.
- d. The initial step in collecting conducted emission data is a spectrum analyzer peak detector mode pre-scanning the measurement frequency range. Significant peaks are then marked and then QuasiPeak detector mode re-measured, above 1G Average detector mode will be instead.
- e. If the Peak Mode measured value compliance with and lower than Quasi Peak Mode Limit, the EUT shall be deemed to meet QP Limits and then no additional QP Mode measurement performed.
- f. For the actual test configuration, please refer to the related Item –EUT Test Photos.

Note:

Both horizontal and vertical antenna polarities were tested.

And performed pretest to three orthogonal axis. The worst case emissions were reported.

3.9 TEST SETUP

(A) Radiated Emission Test Set-Up Frequency Below 30MHz

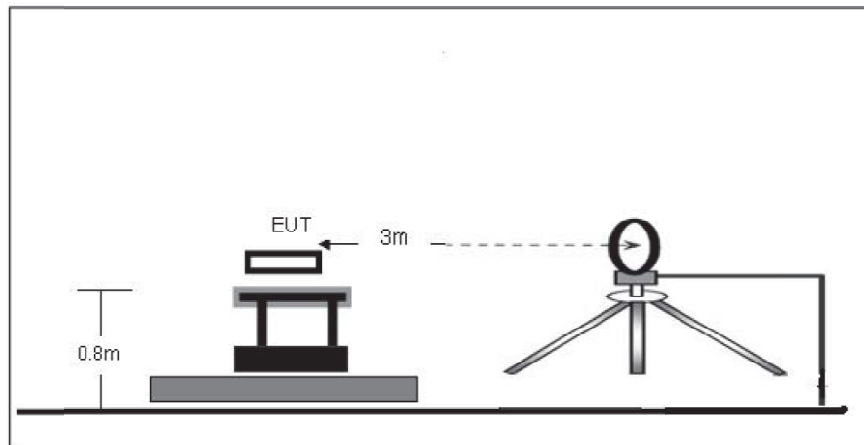

(B) Radiated Emission Test Set-Up Frequency Below 1 GHz

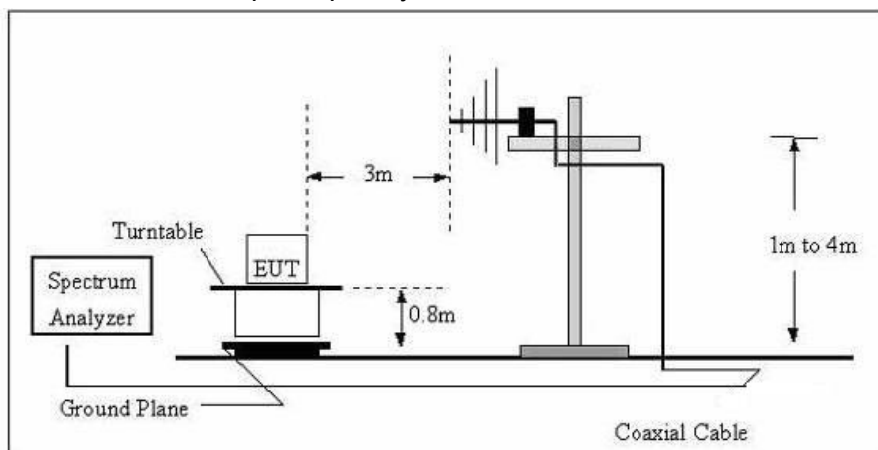

(C) Radiated Emission Test Set-Up Frequency Above 1GHz

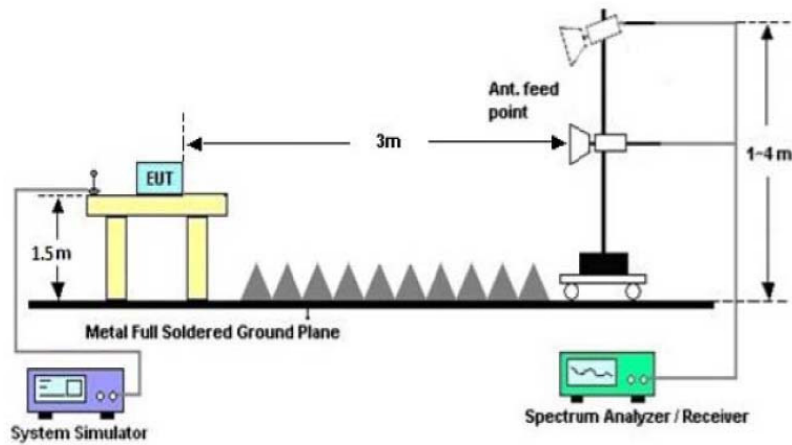

3.10 TEST INSTRUMENTS

Equipment	Manufacturer	Type No.	Serial No.	Last calibration	Calibrated until	Calibration period
Broadband Antenna	R&S	VULB 9168	VULB 9168-456	Jul. 04, 2016	Jul. 03. 2017	1 year
Test Cable	N/A	R-01	N/A	Jul. 04, 2016	Jul. 03. 2017	1 year
Test Cable	N/A	R-02	N/A	Jul. 04, 2016	Jul. 03. 2017	1 year
EMI Test Receiver	R&S	ESCI	101324	Jul. 04, 2016	Jul. 03. 2017	1 year
Antenna Mast	EM	SC100_1	N/A	N/A	N/A	N/A
Turn Table	EM	SC100	060531	N/A	N/A	N/A
50Ω Switch	Anritsu Corp	MP59B	6200983705	Jul. 04, 2016	Jul. 03. 2017	1 year
Spectrum Analyzer	R&S	FSP40	100154	Jul. 04, 2016	Jul. 03. 2017	1 year
Horn Antenna	R&S	HF906	10029	Jul. 04, 2016	Jul. 03. 2017	1 year
Amplifier	EM	EM-30180	060538	Jul. 04, 2016	Jul. 03. 2017	1 year

3.11 EUT OPERATING CONDITIONS

The EUT tested system was configured as the statements of 2.3 Unless otherwise a special operating condition is specified in the follows during the testing.

3.12 TEST RESULTS

3.12.1 TEST RESULTS (Below 1GHz)

EUT :	WIFI Module	Model Name. :	W2CM2510
Temperature :	26 °C	Relative Humidity :	56%
Pressure :	1010 hPa	Test Date :	2016-09-15
Test Mode :	WIFI TX Mode (B 2412MHz)	Polarization:	Horizontal
Test Power :	DC 5V		
Remark :	Only show the worse case.		

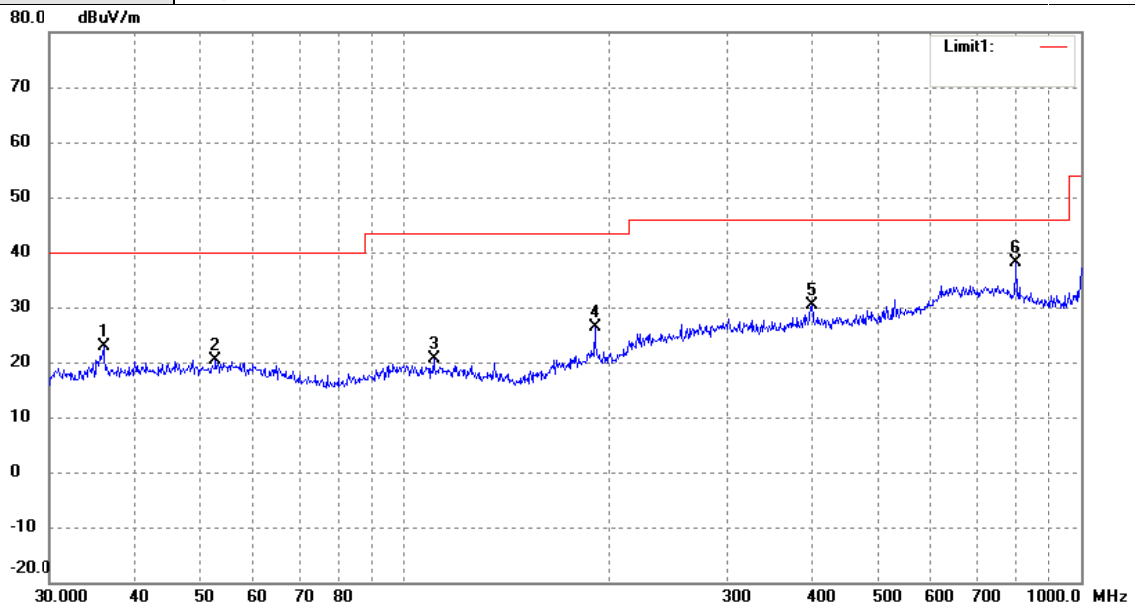

No.	Frequency (MHz)	Reading (dBuV/m)	Correct (dB/m)	Result (dBuV/m)	Limit (dBuV/m)	Margin (dB)	Remark
1	36.0007	18.66	4.33	22.99	40.00	-17.01	peak
2	52.7599	15.36	5.06	20.42	40.00	-19.58	peak
3	110.5687	15.81	4.87	20.68	43.50	-22.82	peak
4	191.0738	23.48	2.94	26.42	43.50	-17.08	peak
5	400.4319	17.59	12.67	30.26	46.00	-15.74	peak
6	801.7863	21.81	16.26	38.07	46.00	-7.93	peak

Remark:
Factor = Antenna Factor + Cable Loss.

EUT :	WIFI Module	Model Name. :	W2CM2510
Temperature :	26 °C	Relative Humidity :	56%
Pressure :	1010 hPa	Test Date :	2016-09-15
Test Mode :	WIFI TX Mode (B 2412MHz)	Polarization:	Vertical
Test Power :	DC 5V		
Remark :	Only show the worse case.		

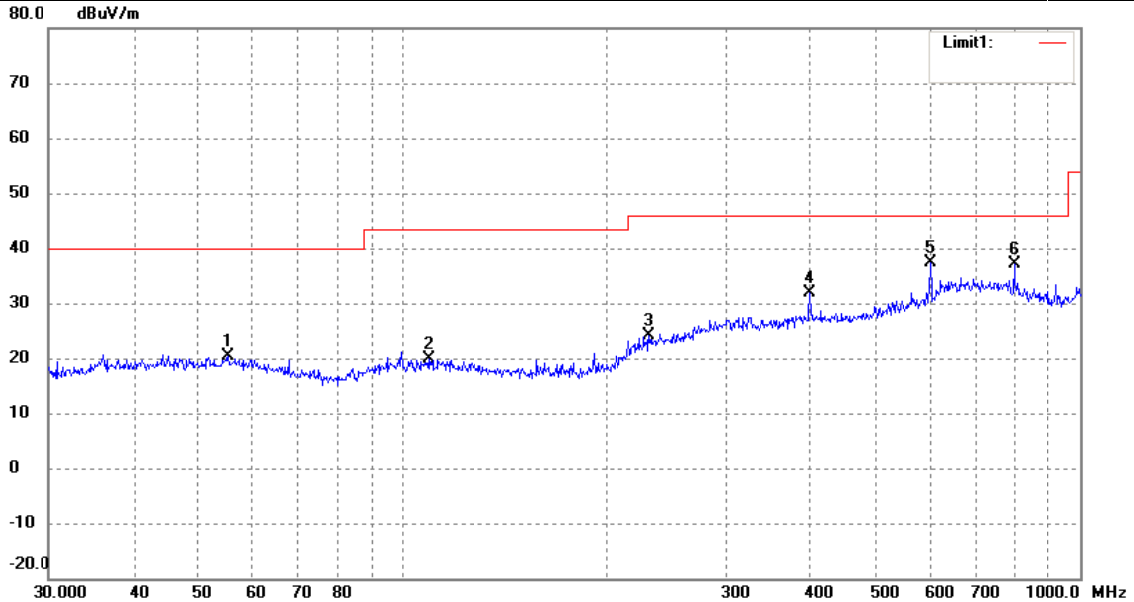

No.	Frequency (MHz)	Reading (dBuV/m)	Correct (dB/m)	Result (dBuV/m)	Limit (dBuV/m)	Margin (dB)	Remark
1	55.2207	15.38	5.02	20.40	40.00	-19.60	peak
2	109.0285	14.91	4.87	19.78	43.50	-23.72	peak
3	230.9068	15.76	8.35	24.11	46.00	-21.89	peak
4	399.0302	19.19	12.64	31.83	46.00	-14.17	peak
5	601.4265	18.77	18.66	37.43	46.00	-8.57	peak
6	798.9797	20.87	16.34	37.21	46.00	-8.79	peak

Remark:
Factor = Antenna Factor + Cable Loss.

3.12.2 TEST RESULTS(Above 1GHz)

EUT :	WIFI Module	Model Name. :	W2CM2510
Temperature :	26 °C	Relative Humidity :	56%
Test Power :	DC 5V	Pressure :	1010 hPa
Test Mode :	WIFI TX Mode (B 2412MHz ANT 1)	Test Date :	2016-09-15
Remark :	Only show the worse case Antenna 1.		

Freq.	Deceiver Reading	Detector	Polar	Corrected Factor	Emission Level	Limit	Margin
MHz	dBuV	Peak/Avg	H/V	dB	dBuV /m	dBuV /m	dB
4824	60.08	Peak	H	-3.62	56.46	74	-17.54
4824	47.19	Avg	H	-3.62	43.57	54	-10.43
7236	55.24	Peak	H	-0.48	54.76	74	-19.24
7236	42.14	Avg	H	-0.48	41.66	54	-12.34
---	---	Peak	H			74	
---	---	Avg	H			54	
4824	59.09	Peak	V	-3.62	55.47	74	-18.53
4824	45.88	Avg	V	-3.62	42.26	54	-11.74
7236	54.10	Peak	V	-0.48	53.62	74	-20.38
7236	40.56	Avg	V	-0.48	40.08	54	-13.92
---	---	Peak	V			74	
---	---	Avg	V			54	

Remark:

Emission Level= Read Level+ Correct Factor

Margin= Emission Level-Limit

The testing has been conformed to 10th harmonics(1G~25G)

Other harmonics emission are lower then 20dB below the allowable Limit

EUT :	WIFI Module	Model Name. :	W2CM2510
Temperature :	26 °C	Relative Humidity :	56%
Test Power :	DC 5V	Pressure :	1010 hPa
Test Mode :	WIFI TX Mode (B 2437MHz ANT 1)	Test Date :	2016-09-15

Remark : Only show the worse case Antenna 1.

Freq.	Deceiver Reading	Detector	Polar	Corrected Factor	Emission Level	Limit	Margin
MHz	dBuV	Peak/Avg	H/V	dB	dBuV /m	dBuV /m	dB
4874	59.62	Peak	H	-3.6	56.02	74	-17.98
4874	46.86	Avg	H	-3.6	43.26	54	-10.74
7311	54.93	Peak	H	-0.46	54.47	74	-19.53
7311	41.92	Avg	H	-0.46	41.46	54	-12.54
---	---	Peak	H			74	
---	---	Avg	H			54	

4874	59.06	Peak	V	-3.6	55.46	74	-18.54
4874	45.93	Avg	V	-3.6	42.33	54	-11.67
7311	53.34	Peak	V	-0.46	52.88	74	-21.12
7311	40.79	Avg	V	-0.46	40.33	54	-13.67
---	---	Peak	V			74	
---	---	Avg	V			54	

Remark:

Emission Level= Read Level+ Correct Factor

Margin= Emission Level-Limit

The testing has been conformed to 10th harmonics(1G~25G)

Other harmonics emission are lower then 20dB below the allowable Limit

EUT :	WIFI Module	Model Name. :	W2CM2510
Temperature :	26 °C	Relative Humidity :	56%
Test Power :	DC 5V	Pressure :	1010 hPa
Test Mode :	WIFI TX Mode (B 2462MHz ANT 1)	Test Date :	2016-09-15

Remark : Only show the worse case Antenna 1.

Freq.	Deceiver Reading	Detector	Polar	Corrected Factor	Emission Level	Limit	Margin
MHz	dBuV	Peak/Avg	H/V	dB	dBuV /m	dBuV /m	dB
4924	59.74	Peak	H	-3.59	56.15	74	-17.85
4924	47.27	Avg	H	-3.59	43.68	54	-10.32
7386	55.00	Peak	H	-0.43	54.57	74	-19.43
7386	42.40	Avg	H	-0.43	41.97	54	-12.03
---	---	Peak	H			74	
---	---	Avg	H			54	

4924	59.57	Peak	V	-3.59	55.98	74	-18.02
4924	45.14	Avg	V	-3.59	41.55	54	-12.45
7386	54.10	Peak	V	-0.43	53.67	74	-20.33
7386	40.81	Avg	V	-0.43	40.38	54	-13.62
---	---	Peak	V			74	
---	---	Avg	V			54	

Remark:

Emission Level= Read Level+ Correct Factor

Margin= Emission Level-Limit

The testing has been conformed to 10th harmonics(1G~25G)

Other harmonics emission are lower then 20dB below the allowable Limit

EUT :	WIFI Module	Model Name. :	W2CM2510
Temperature :	26 °C	Relative Humidity :	56%
Test Power :	DC 5V	Pressure :	1010 hPa
Test Mode :	WIFI TX Mode (G 2412MHz ANT 1)	Test Date :	2016-09-15

Remark : Only show the worse case Antenna 1.

Freq.	Deceiver Reading	Detector	Polar	Corrected Factor	Emission Level	Limit	Margin
MHz	dBuV	Peak/Avg	H/V	dB	dBuV /m	dBuV /m	dB
4824	59.68	Peak	H	-3.62	56.06	74	-17.94
4824	46.39	Avg	H	-3.62	42.77	54	-11.23
7236	56.06	Peak	H	-0.48	55.58	74	-18.42
7236	42.94	Avg	H	-0.48	42.46	54	-11.54
---	---	Peak	H			74	
---	---	Avg	H			54	

4824	60.63	Peak	V	-3.62	57.01	74	-16.99
4824	47.59	Avg	V	-3.62	43.97	54	-10.03
7236	54.05	Peak	V	-0.48	53.57	74	-20.43
7236	40.83	Avg	V	-0.48	40.35	54	-13.65
---	---	Peak	V			74	
---	---	Avg	V			54	

Remark:

Emission Level= Read Level+ Correct Factor

Margin= Emission Level-Limit

The testing has been conformed to 10th harmonics(1G~25G)

Other harmonics emission are lower then 20dB below the allowable Limit

EUT :	WIFI Module	Model Name. :	W2CM2510
Temperature :	26 °C	Relative Humidity :	56%
Test Power :	DC 5V	Pressure :	1010 hPa
Test Mode :	WIFI TX Mode (G 2437MHz ANT 1)	Test Date :	2016-09-15

Remark : Only show the worse case Antenna 1.

Freq.	Deceiver Reading	Detector	Polar	Corrected Factor	Emission Level	Limit	Margin
MHz	dBuV	Peak/Avg	H/V	dB	dBuV /m	dBuV /m	dB
4874	60.77	Peak	H	-3.6	57.17	74	-16.83
4874	48.17	Avg	H	-3.6	44.57	54	-9.43
7311	53.02	Peak	H	-0.46	52.56	74	-21.44
7311	40.68	Avg	H	-0.46	40.22	54	-13.78
---	---	Peak	H			74	
---	---	Avg	H			54	

4874	60.28	Peak	V	-3.6	56.68	74	-17.32
4874	46.96	Avg	V	-3.6	43.36	54	-10.64
7311	55.03	Peak	V	-0.46	54.57	74	-19.43
7311	42.01	Avg	V	-0.46	41.55	54	-12.45
---	---	Peak	V			74	
---	---	Avg	V			54	

Remark:

Emission Level= Read Level+ Correct Factor

Margin= Emission Level-Limit

The testing has been conformed to 10th harmonics(1G~25G)

Other harmonics emission are lower then 20dB below the allowable Limit

EUT :	WIFI Module	Model Name. :	W2CM2510
Temperature :	26 °C	Relative Humidity :	56%
Test Power :	DC 5V	Pressure :	1010 hPa
Test Mode :	WIFI TX Mode (G 2462MHz ANT 1)	Test Date :	2016-09-15

Remark : Only show the worse case Antenna 1.

Freq.	Deceiver Reading	Detector	Polar	Corrected Factor	Emission Level	Limit	Margin
MHz	dBuV	Peak/Avg	H/V	dB	dBuV /m	dBuV /m	dB
4924	60.14	Peak	H	-3.59	56.55	74	-17.45
4924	46.70	Avg	H	-3.59	43.11	54	-10.89
7386	54.66	Peak	H	-0.43	54.23	74	-19.77
7386	41.89	Avg	H	-0.43	41.46	54	-12.54
---	---	Peak	H			74	
---	---	Avg	H			54	

4924	59.16	Peak	V	-3.59	55.57	74	-18.43
4924	44.83	Avg	V	-3.59	41.24	54	-12.76
7386	54.96	Peak	V	-0.43	54.53	74	-19.47
7386	42.48	Avg	V	-0.43	42.05	54	-11.95
---	---	Peak	V			74	
---	---	Avg	V			54	

Remark:

Emission Level= Read Level+ Correct Factor

Margin= Emission Level-Limit

The testing has been conformed to 10th harmonics(1G~25G)

Other harmonics emission are lower then 20dB below the allowable Limit

EUT :	WIFI Module	Model Name. :	W2CM2510
Temperature :	26 °C	Relative Humidity :	56%
Test Power :	DC 5V	Pressure :	1010 hPa
Test Mode :	WIFI TX Mode (N20 2412MHz ANT 1+2)	Test Date :	2016-09-15

Remark : Only show the worse case.

Freq.	Deceiver Reading	Detector	Polar	Corrected Factor	Emission Level	Limit	Margin
MHz	dBuV	Peak/Avg	H/V	dB	dBuV /m	dBuV /m	dB
4824	58.19	Peak	H	-3.62	54.57	74	-19.43
4824	45.08	Avg	H	-3.62	41.46	54	-12.54
7236	52.94	Peak	H	-0.48	52.46	74	-21.54
7236	40.16	Avg	H	-0.48	39.68	54	-14.32
---	---	Peak	H			74	
---	---	Avg	H			54	
4824	58.69	Peak	V	-3.62	55.07	74	-18.93
4824	46.26	Avg	V	-3.62	42.64	54	-11.36
7236	53.91	Peak	V	-0.48	53.43	74	-20.57
7236	40.76	Avg	V	-0.48	40.28	54	-13.72
---	---	Peak	V			74	
---	---	Avg	V			54	

Remark:

Emission Level= Read Level+ Correct Factor

Margin= Emission Level-Limit

The testing has been conformed to 10th harmonics(1G~25G)

Other harmonics emission are lower then 20dB below the allowable Limit

EUT :	WIFI Module	Model Name. :	W2CM2510
Temperature :	26 °C	Relative Humidity :	56%
Test Power :	DC 5V	Pressure :	1010 hPa
Test Mode :	WIFI TX Mode (N20 2437MHz ANT 1+2)	Test Date :	2016-09-15

Remark : Only show the worse case .

Freq.	Deceiver Reading	Detector	Polar	Corrected Factor	Emission Level	Limit	Margin
MHz	dBuV	Peak/Avg	H/V	dB	dBuV /m	dBuV /m	dB
4874	58.25	Peak	H	-3.6	54.65	74	-19.35
4874	45.46	Avg	H	-3.6	41.86	54	-12.14
7311	53.78	Peak	H	-0.46	53.32	74	-20.68
7311	37.04	Avg	H	-0.46	36.58	54	-17.42
---	---	Peak	H			74	
---	---	Avg	H			54	

4874	57.27	Peak	V	-3.6	53.67	74	-20.33
4874	44.03	Avg	V	-3.6	40.43	54	-13.57
7311	51.82	Peak	V	-0.46	51.36	74	-22.64
7311	38.82	Avg	V	-0.46	38.36	54	-15.64
---	---	Peak	V			74	
---	---	Avg	V			54	

Remark:

Emission Level= Read Level+ Correct Factor

Margin= Emission Level-Limit

The testing has been conformed to 10th harmonics(1G~25G)

Other harmonics emission are lower then 20dB below the allowable Limit

EUT :	WIFI Module	Model Name. :	W2CM2510
Temperature :	26 °C	Relative Humidity :	56%
Test Power :	DC 5V	Pressure :	1010 hPa
Test Mode :	WIFI TX Mode (N20 2462MHz ANT 1+2)	Test Date :	2016-09-15

Remark : Only show the worse case .

Freq.	Deceiver Reading	Detector	Polar	Corrected Factor	Emission Level	Limit	Margin
MHz	dBuV	Peak/Avg	H/V	dB	dBuV /m	dBuV /m	dB
4924	59.24	Peak	H	-3.59	55.65	74	-18.35
4924	46.03	Avg	H	-3.59	42.44	54	-11.56
7386	53.98	Peak	H	-0.43	53.55	74	-20.45
7386	41.49	Avg	H	-0.43	41.06	54	-12.94
---	---	Peak	H			74	
---	---	Avg	H			54	

4924	57.76	Peak	V	-3.59	54.17	74	-19.83
4924	44.85	Avg	V	-3.59	41.26	54	-12.74
7386	52.89	Peak	V	-0.43	52.46	74	-21.54
7386	39.79	Avg	V	-0.43	39.36	54	-14.64
---	---	Peak	V			74	
---	---	Avg	V			54	

Remark:

Emission Level= Read Level+ Correct Factor

Margin= Emission Level-Limit

The testing has been conformed to 10th harmonics(1G~25G)

Other harmonics emission are lower then 20dB below the allowable Limit

EUT :	WIFI Module	Model Name. :	W2CM2510
Temperature :	26 °C	Relative Humidity :	56%
Test Power :	DC 5V	Pressure :	1010 hPa
Test Mode :	WIFI TX Mode (N40 2422MHz ANT 1+2)	Test Date :	2016-09-15

Remark : Only show the worse case.

Freq.	Deceiver Reading	Detector	Polar	Corrected Factor	Emission Level	Limit	Margin
MHz	dBuV	Peak/Avg	H/V	dB	dBuV /m	dBuV /m	dB
4844	59.08	Peak	H	-3.62	55.46	74	-18.54
4844	44.98	Avg	H	-3.62	41.36	54	-12.64
7266	54.02	Peak	H	-0.48	53.54	74	-20.46
7266	41.24	Avg	H	-0.48	40.76	54	-13.24
---	---	Peak	H			74	
---	---	Avg	H			54	
4844	58.3	Peak	V	-3.62	54.68	74	-19.32
4844	45.09	Avg	V	-3.62	41.47	54	-12.53
7266	53.95	Peak	V	-0.48	53.47	74	-20.53
7266	41.79	Avg	V	-0.48	41.31	54	-12.69
---	---	Peak	V			74	
---	---	Avg	V			54	

Remark:

Emission Level= Read Level+ Correct Factor

Margin= Emission Level-Limit

The testing has been conformed to 10th harmonics(1G~25G)

Other harmonics emission are lower then 20dB below the allowable Limit

EUT :	WIFI Module	Model Name. :	W2CM2510
Temperature :	26 °C	Relative Humidity :	56%
Test Power :	DC 5V	Pressure :	1010 hPa
Test Mode :	WIFI TX Mode (N40 2437MHz ANT 1+2)	Test Date :	2016-09-15

Remark : Only show the worse case .

Freq.	Deceiver Reading	Detector	Polar	Corrected Factor	Emission Level	Limit	Margin
MHz	dBuV	Peak/Avg	H/V	dB	dBuV /m	dBuV /m	dB
4874	58.96	Peak	H	-3.6	55.36	74	-18.64
4874	47.29	Avg	H	-3.6	43.69	54	-10.31
7311	54.03	Peak	H	-0.46	53.57	74	-20.43
7311	41.7	Avg	H	-0.46	41.24	54	-12.76
---	---	Peak	H			74	
---	---	Avg	H			54	

4874	58.17	Peak	V	-3.6	54.57	74	-19.43
4874	46.28	Avg	V	-3.6	42.68	54	-11.32
7311	52.92	Peak	V	-0.46	52.46	74	-21.54
7311	40.09	Avg	V	-0.46	39.63	54	-14.37
---	---	Peak	V			74	
---	---	Avg	V			54	

Remark:

Emission Level= Read Level+ Correct Factor

Margin= Emission Level-Limit

The testing has been conformed to 10th harmonics(1G~25G)

Other harmonics emission are lower then 20dB below the allowable Limit

EUT :	WIFI Module	Model Name. :	W2CM2510
Temperature :	26 °C	Relative Humidity :	56%
Test Power :	DC 5V	Pressure :	1010 hPa
Test Mode :	WIFI TX Mode (N40 2452MHz ANT 1+2)	Test Date :	2016-09-15

Remark : Only show the worse case .

Freq.	Deceiver Reading	Detector	Polar	Corrected Factor	Emission Level	Limit	Margin
MHz	dBuV	Peak/Avg	H/V	dB	dBuV /m	dBuV /m	dB
4904	59.14	Peak	H	-3.59	55.55	74	-18.45
4904	46.05	Avg	H	-3.59	42.46	54	-11.54
7356	53.89	Peak	H	-0.43	53.46	74	-20.54
7356	42.05	Avg	H	-0.43	41.62	54	-12.38
---	---	Peak	H			74	
---	---	Avg	H			54	

4904	59.13	Peak	V	-3.59	55.54	74	-18.46
4904	45.55	Avg	V	-3.59	41.96	54	-12.04
7356	54.54	Peak	V	-0.43	54.11	74	-19.89
7356	42.98	Avg	V	-0.43	42.55	54	-11.45
---	---	Peak	V			74	
---	---	Avg	V			54	

Remark:

Emission Level= Read Level+ Correct Factor

Margin= Emission Level-Limit

The testing has been conformed to 10th harmonics(1G~25G)

Other harmonics emission are lower then 20dB below the allowable Limit

4. MAXIMUM CONDUCTED OUTPUT POWER MEASUREMENT

4.1 LIMITS

FCC Part 15.247, subpart C/ RSS 247Section 5.4(4)	
Frequency Range (MHz)	2400~2483.5
Limits	30

4.2 TEST PROCEDURE

The measurement is according to section 9.1.2 of FCC KDB 558074 D01 DTS Meas Guidance v03r05.

The EUT was directly connected to the power meter and antenna output port as show in the block diagram as bellow.

4.3 TEST SETUP

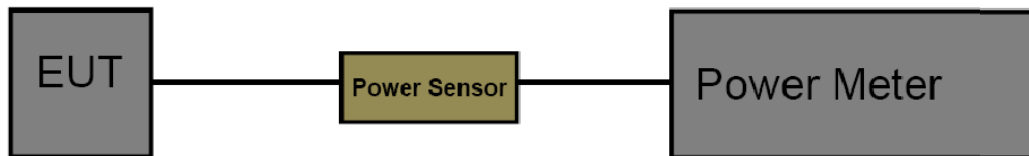

4.4 TEST INSTRUMENTS

Equipment	Manufacturer	Type No.	Serial No.	Last calibration	Calibrated until	Calibration period
P-Series Power Meter	Agilent	N1911A	MY45100482	Jul. 04, 2016	Jul. 03. 2017	1 year
Wideband Power Sensor	Agilent	N1921A	MY51200145	Jul. 04, 2016	Jul. 03. 2017	1 year

4.5 EUT OPERATING CONDITIONS

The EUT was set to continuously transmitting in the maximum power during the test.

4.6 TEST RESULTS

2.4 G Band Conducted Power					
802.11b Power					
Channel	Frequency	Conducted Power (dBm)			Max. Limit (dBm)
		Ant. 1	Ant. 2	Total	
1	2412 MHz	17.88	17.84	---	30
6	2437 MHz	17.85	17.79	---	
11	2462 MHz	17.90	17.73	---	
802.11g Power					
Channel	Frequency	Conducted Power (dBm)			Max. Limit (dBm)
		Ant. 1	Ant. 2	Total	
1	2412 MHz	17.64	17.59	---	30
6	2437 MHz	17.67	17.64	---	
11	2462 MHz	17.74	17.68	---	
802.11n(HT20) Power					
Channel	Frequency	Conducted Power (dBm)			Max. Limit (dBm)
		Ant. 1	Ant. 2	Total	
1	2412 MHz	11.39	10.57	14.01	30
6	2437 MHz	11.30	10.34	13.86	
11	2462 MHz	11.26	10.28	13.81	
802.11n(HT40) Power					
Channel	Frequency	Conducted Power (dBm)			Max. Limit (dBm)
		Ant. 1	Ant. 2	Total	
3	2422 MHz	12.54	11.30	14.97	30
6	2437 MHz	11.88	11.01	14.48	
9	2452 MHz	11.63	11.14	14.40	

Test Mode	Duty cycle
802.11 b	>98%
802.11 g	
802.11 n(HT20)	
802.11 n(HT40)	
Please see the next plots.	

802.11 b Mode 2437MHz

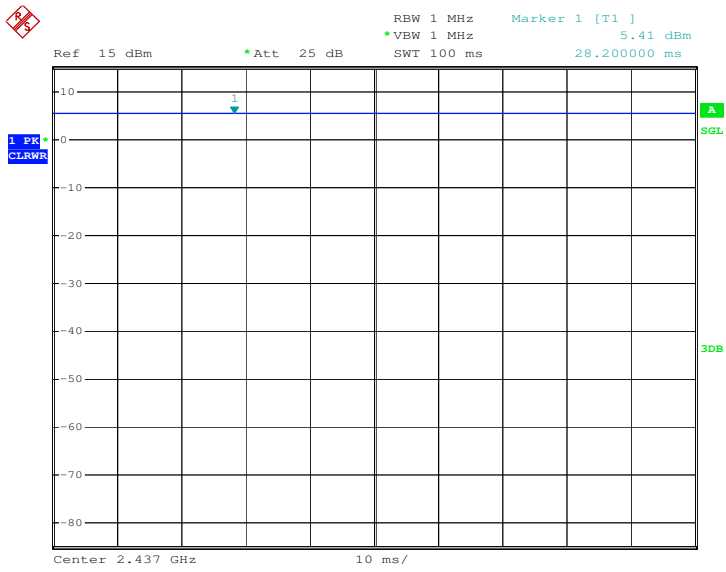

Date: 15.SEP.2016 16:53:10

802.11 g Mode 2437MHz

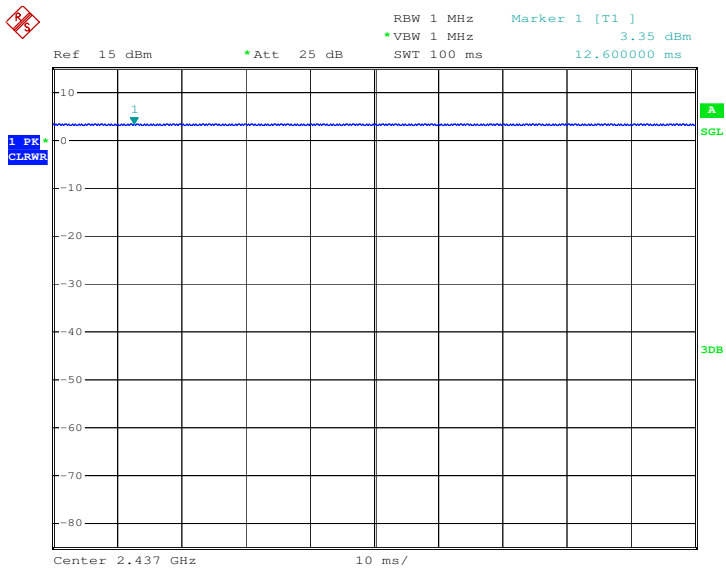

Date: 15.SEP.2016 16:52:36

802.11 n(HT20) Mode 2437MHz

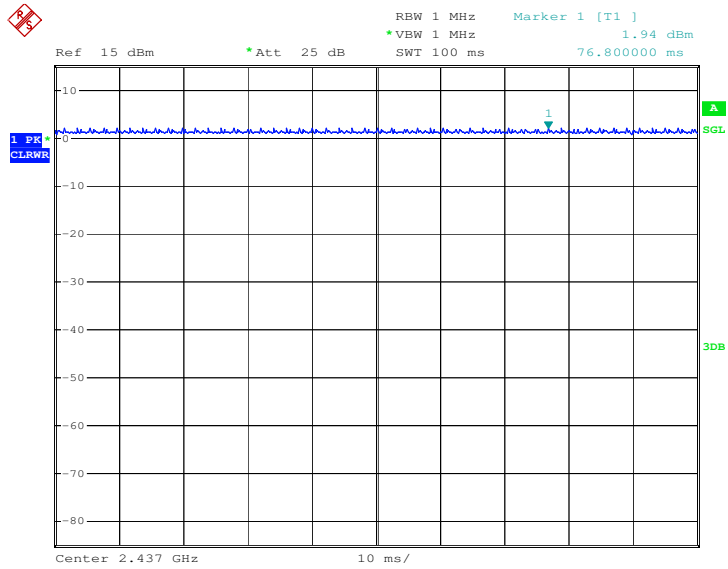

Date: 15.SEP.2016 16:52:09

802.11 n(HT40) Mode 2437MHz

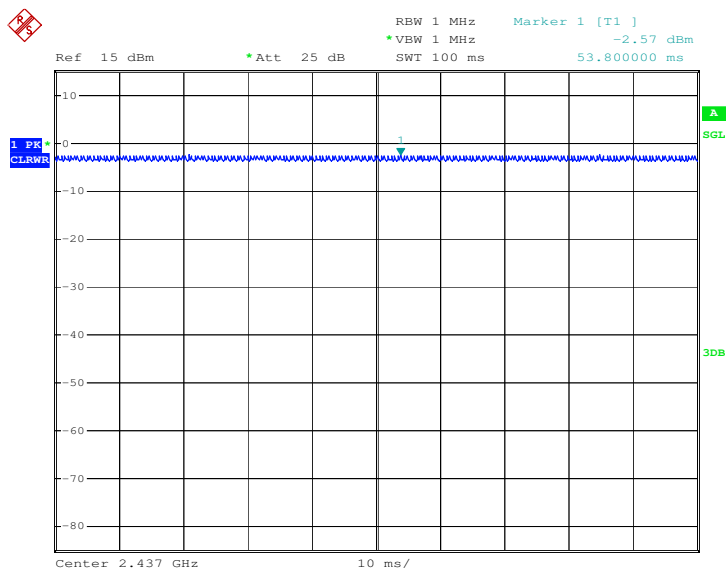

Date: 15.SEP.2016 16:51:17

5. OCCUPIED BANDWIDTH MEASUREMENT

5.1 LIMITS

FCC Part 15.247, subpart C/RSS 247Section 5.2(1)	
Frequency Range (MHz)	2400~2483.5
Limits	6 dB Bandwidth>500 KHz

5.2 TEST PROCEDURE

The EUT was directly connected to the power meter and antenna output port as show in the block diagram as bellow.

Spectrum Parameters	Setting
Attenuation	Auto
Span	>6 dB Bandwidth
RBW	100 kHz
VBW	$\geq 3RBW$
Detector	Peak
Trace	Max Hold
Sweep Time	Auto

5.3 TEST SETUP

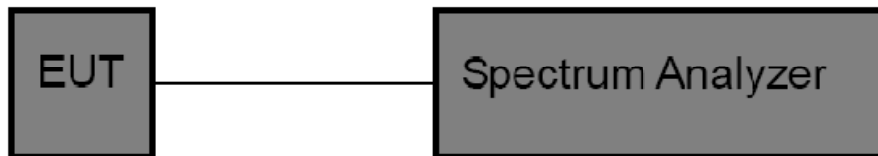

5.4 TEST INSTRUMENTS

Equipment	Manufacturer	Type No.	Serial No.	Last calibration	Calibrated until	Calibration period
Spectrum Analyzer	R&S	FSP40	100154	Jul. 04, 2016	Jul. 03. 2017	1 year

5.5 EUT OPERATING CONDITIONS

The EUT was set to continuously transmitting in the maximum power during the test.

5.6 TEST RESULTS

801.11b Mode ANT. 1			
Frequency (MHz)	6dB Bandwidth (MHz)	99% OBW (MHz)	Limit
2412	9.480	14.20	≥500 kHz
2437	10.000	14.24	
2462	10.000	14.20	

B Mode 2412 MHz ANT. 1

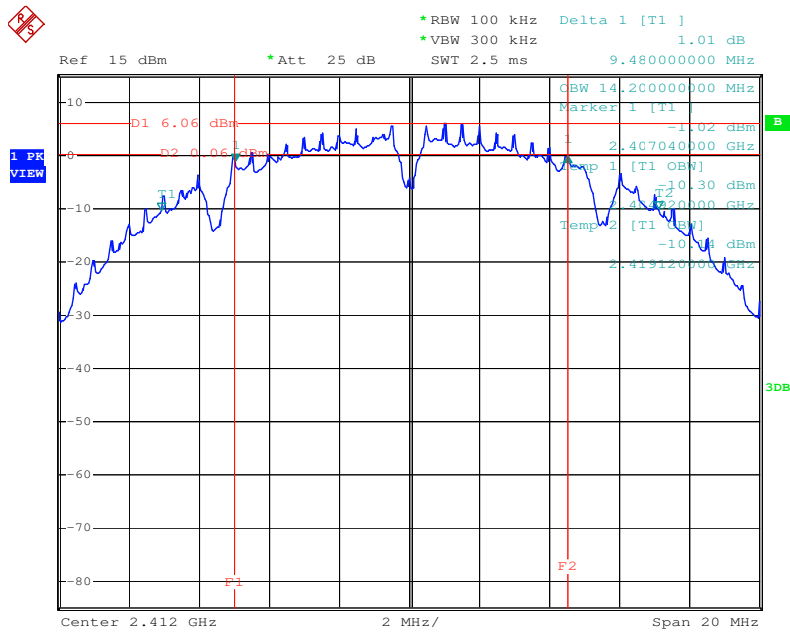

Date: 14.SEP.2016 13:02:22

B Mode 2437 MHz ANT. 1

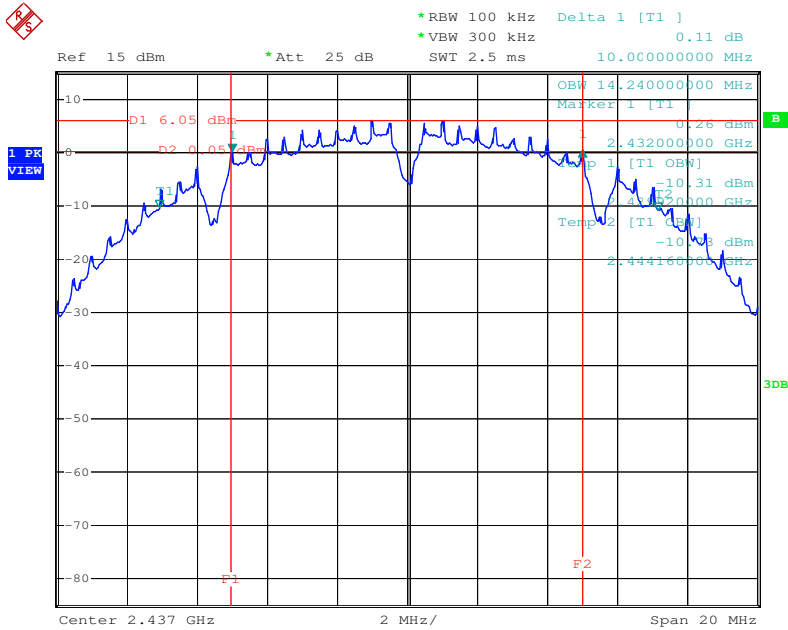

Date: 14.SEP.2016 13:04:16

B Mode 2462 MHz ANT. 1

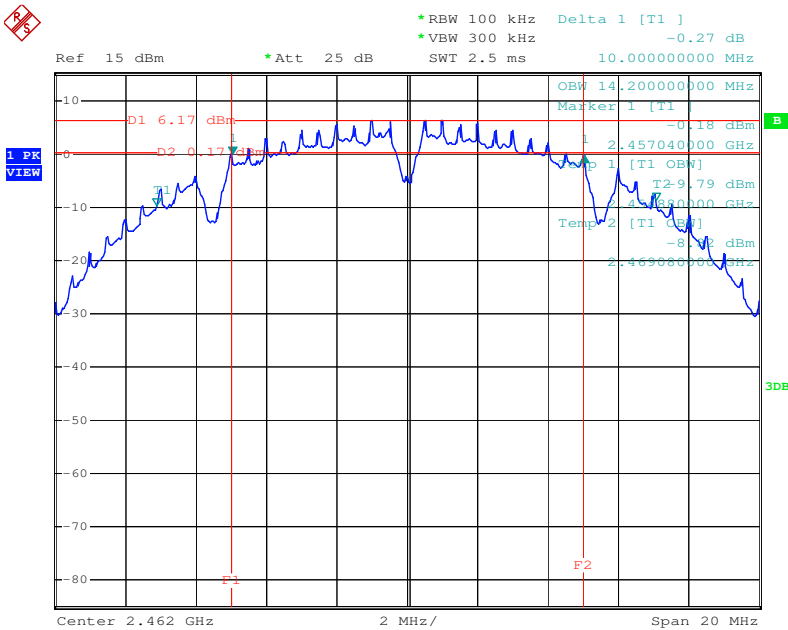

Date: 14.SEP.2016 13:06:05

801.11b ModeANT. 2			
Frequency (MHz)	6dB Bandwidth (MHz)	99% OBW (MHz)	Limit
2412	10.000	14.28	≥500 kHz
2437	10.080	14.36	
2462	10.080	14.32	

B Mode 2412 MHz ANT. 2

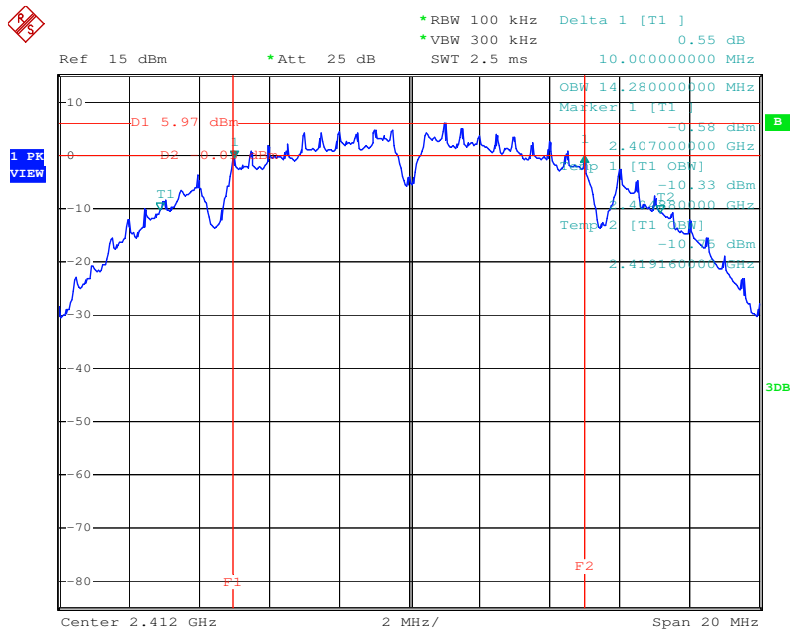

Date: 18.SEP.2016 12:38:01

B Mode 2437 MHz ANT. 2

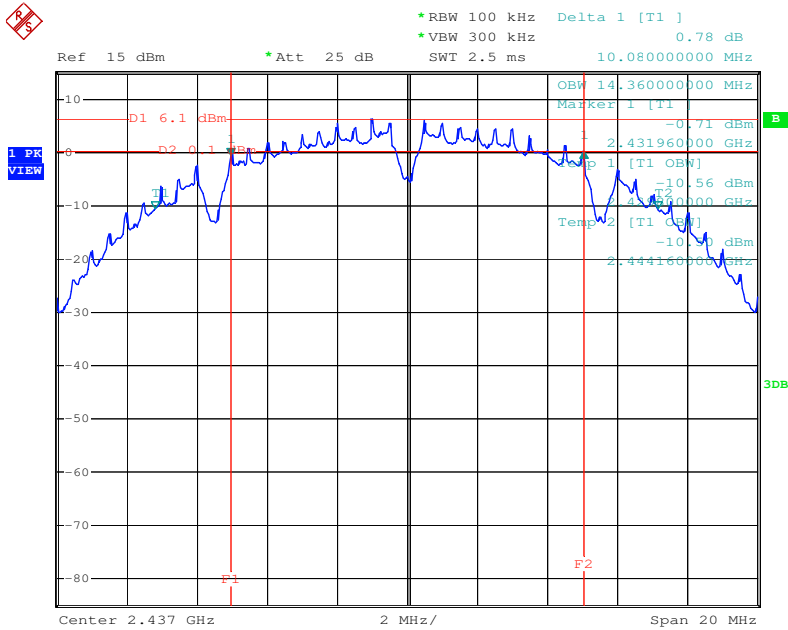

Date: 18.SEP.2016 12:40:22

B Mode 2462 MHz ANT. 2

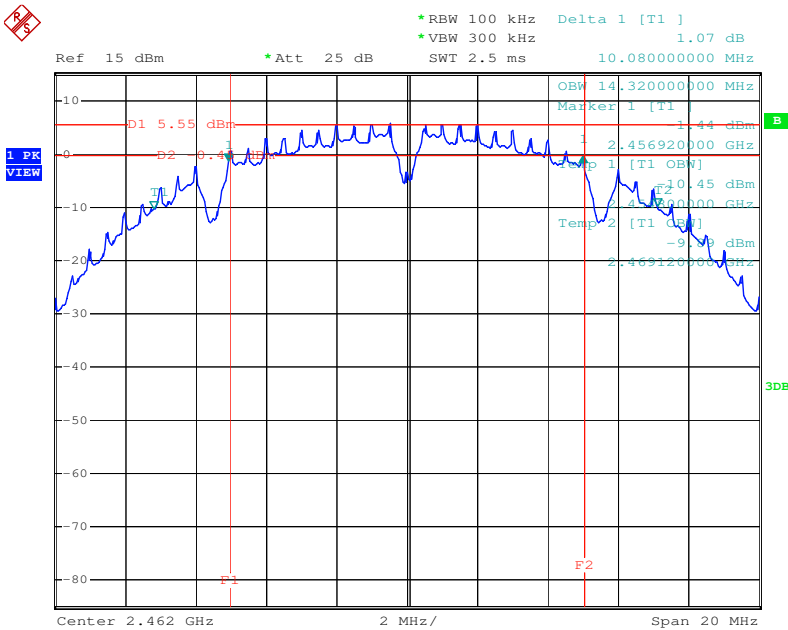

Date: 18.SEP.2016 12:41:56

801.11g ModeANT. 1			
Frequency (MHz)	6dB Bandwidth (MHz)	99% OBW (MHz)	Limit
2412	15.200	16.32	≥500 kHz
2437	15.200	16.32	
2462	15.200	16.32	

G Mode 2412 MHz ANT. 1

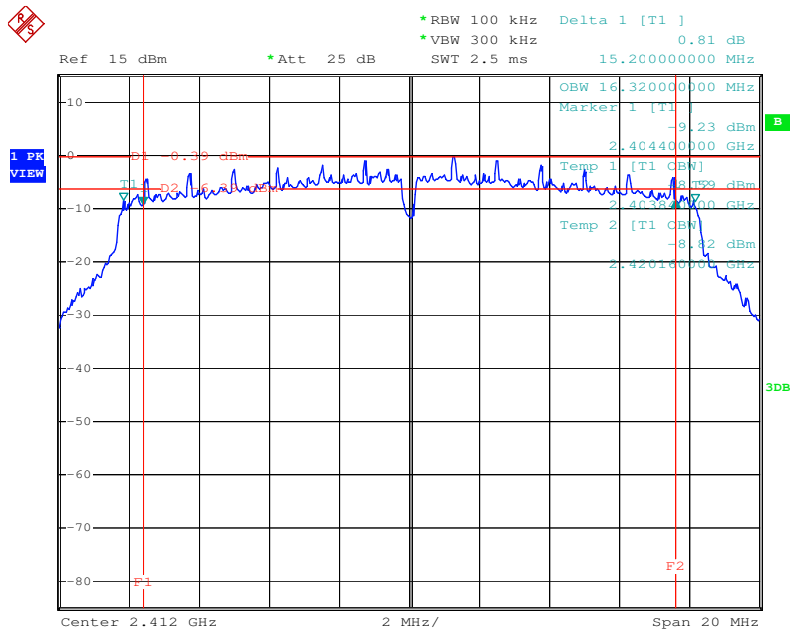

Date: 14.SEP.2016 13:14:57

G Mode 2437 MHz ANT. 1

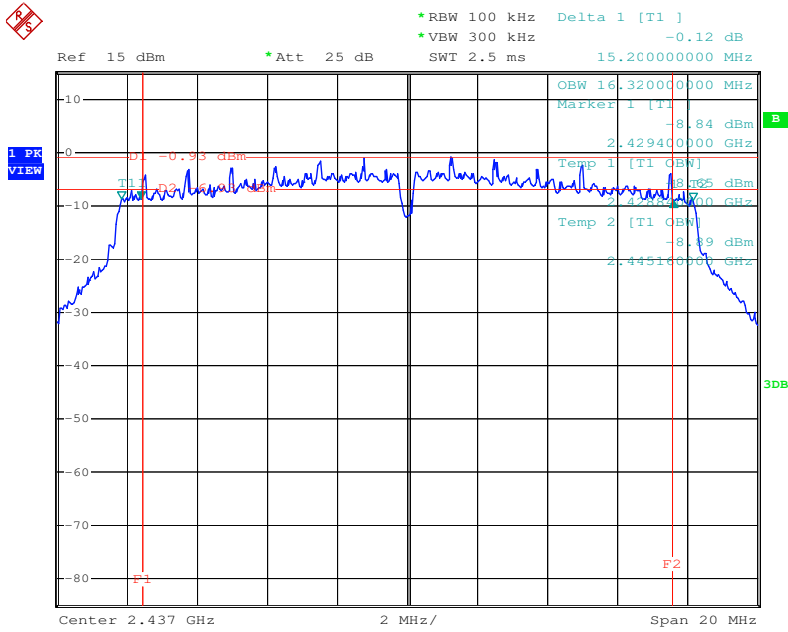

Date: 14.SEP.2016 13:16:32

G Mode 2462 MHz ANT. 1

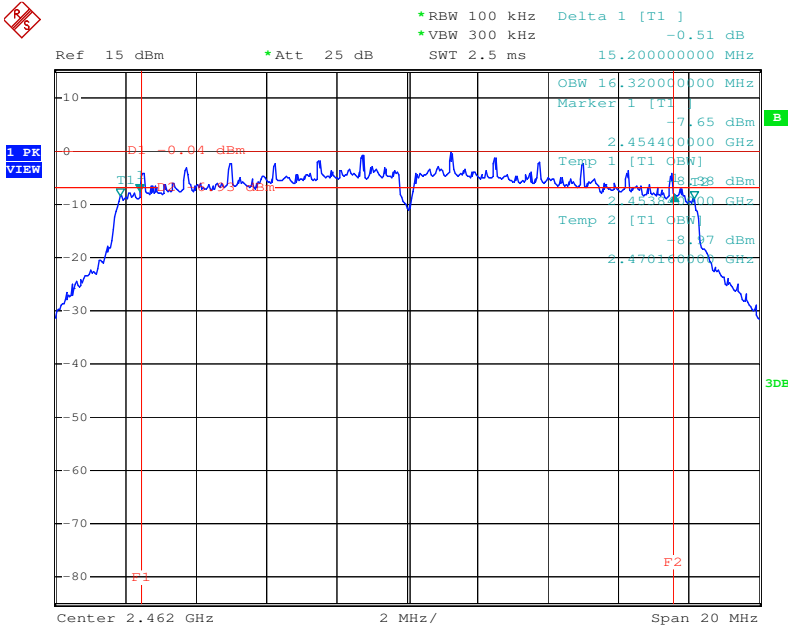

Date: 14.SEP.2016 13:18:22

801.11g ModeANT. 2			
Frequency (MHz)	6dB Bandwidth (MHz)	99% OBW (MHz)	Limit
2412	15.120	16.32	≥500 kHz
2437	15.080	16.32	
2462	15.160	16.36	

G Mode 2412 MHz ANT. 2

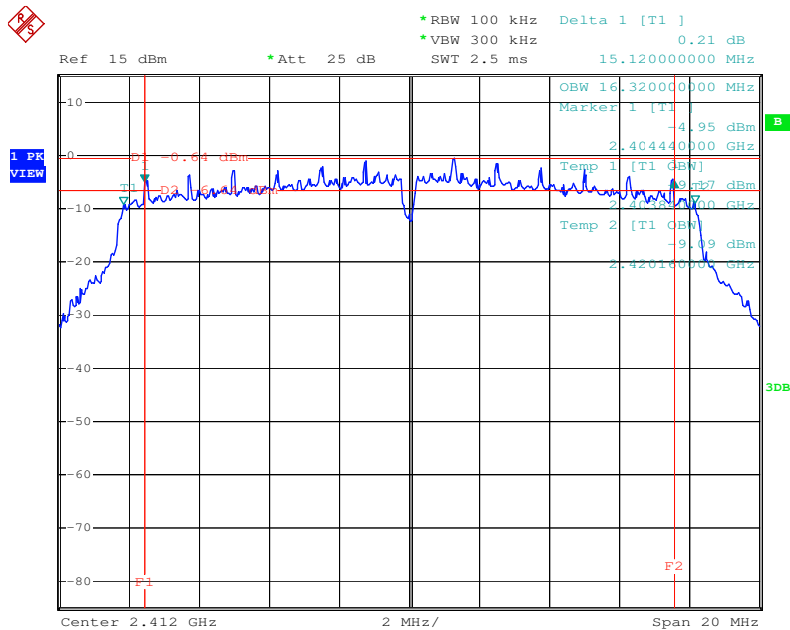

Date: 18.SEP.2016 12:47:07

G Mode 2437 MHz ANT. 2

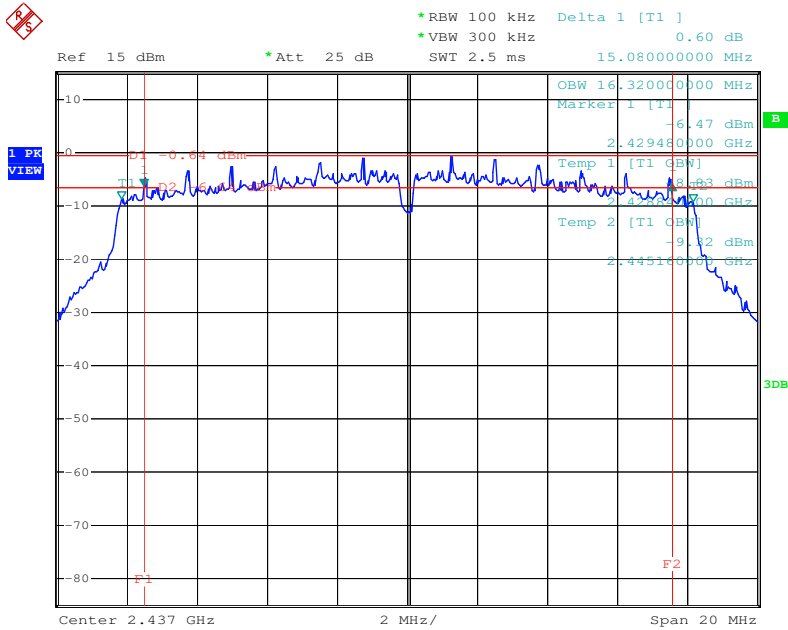

Date: 18.SEP.2016 12:44:58

G Mode 2462 MHz ANT. 2

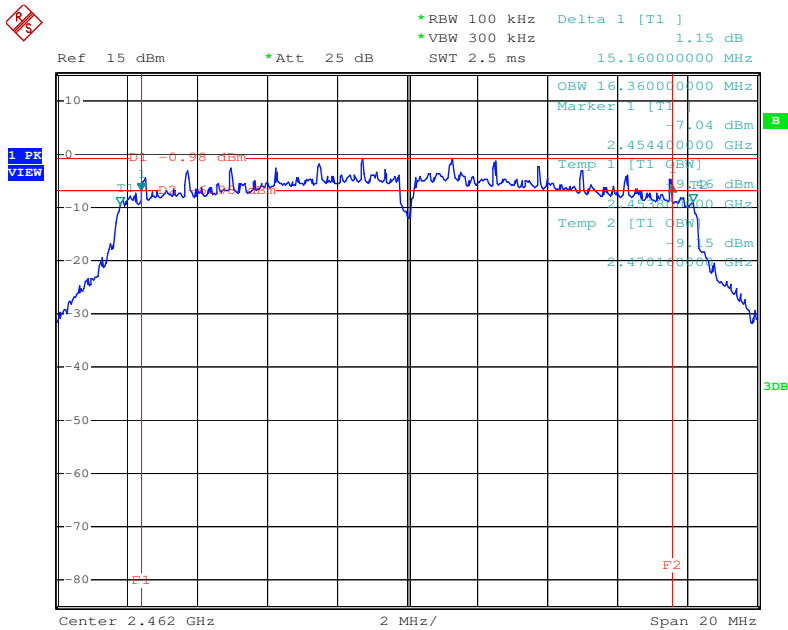

Date: 18.SEP.2016 12:43:49

801.11n(HT20) ModeANT. 1			
Frequency (MHz)	6dB Bandwidth (MHz)	99% OBW (MHz)	Limit
2412	15.200	17.52	≥500 kHz
2437	15.760	17.52	
2462	15.760	17.56	

N Mode 2412 MHz ANT.1

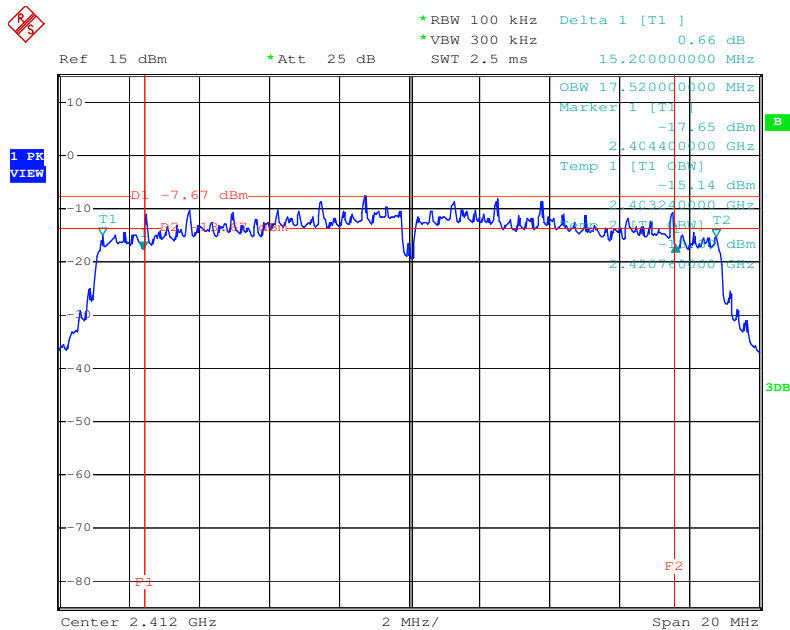

Date: 14.SEP.2016 13:24:05

N Mode 2437 MHz ANT.1

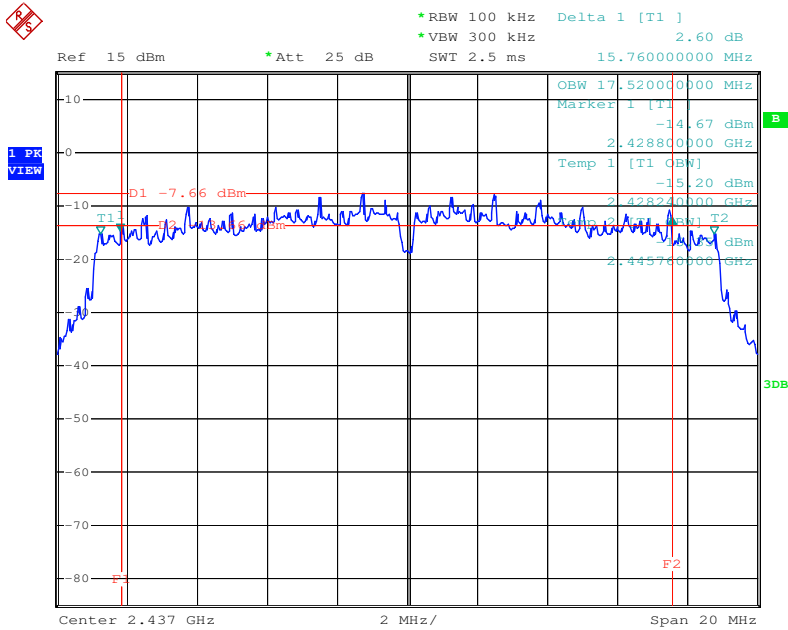

Date: 14.SEP.2016 13:26:45

N Mode 2462 MHz ANT.1

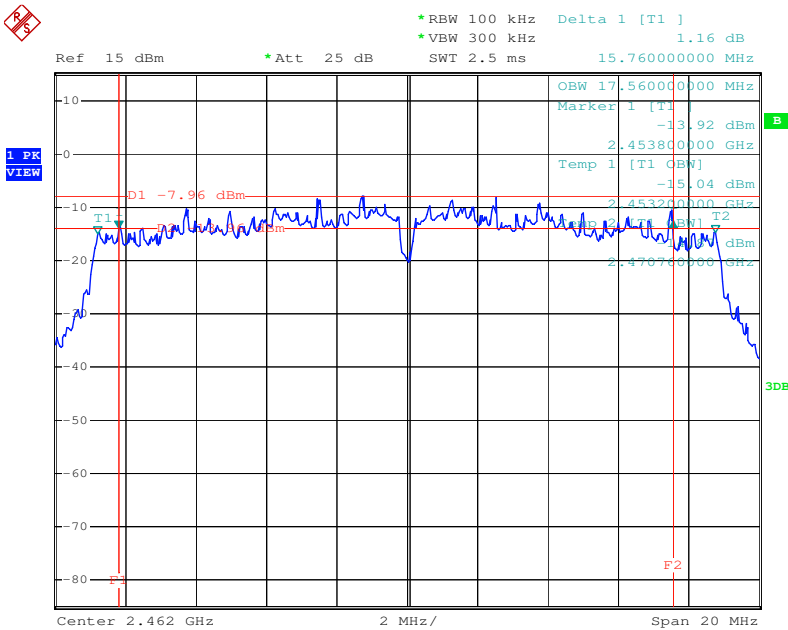

Date: 14.SEP.2016 13:28:44

801.11n(HT20) Mode ANT. 2			
Frequency (MHz)	6dB Bandwidth (MHz)	99% OBW (MHz)	Limit
2412	15.160	17.52	≥500 kHz
2437	15.120	17.52	
2462	15.160	17.52	

N Mode 2412 MHz ANT.2

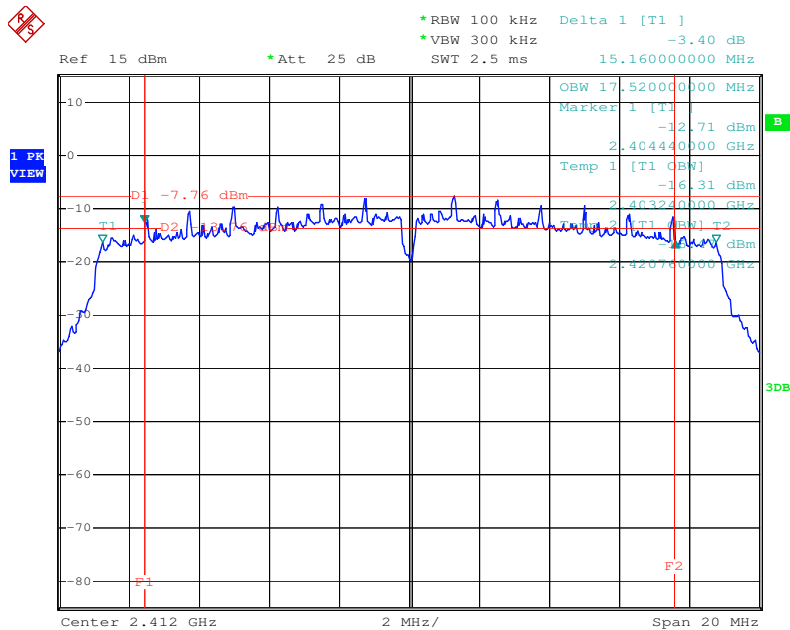

Date: 18.SEP.2016 12:49:45

N Mode 2437 MHz ANT.2

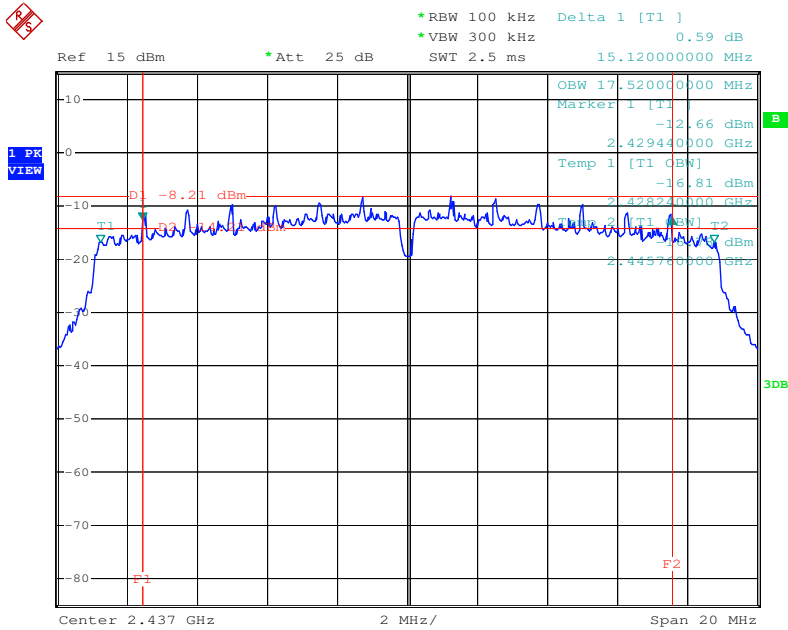

Date: 18.SEP.2016 12:52:48

N Mode 2462 MHz ANT.2

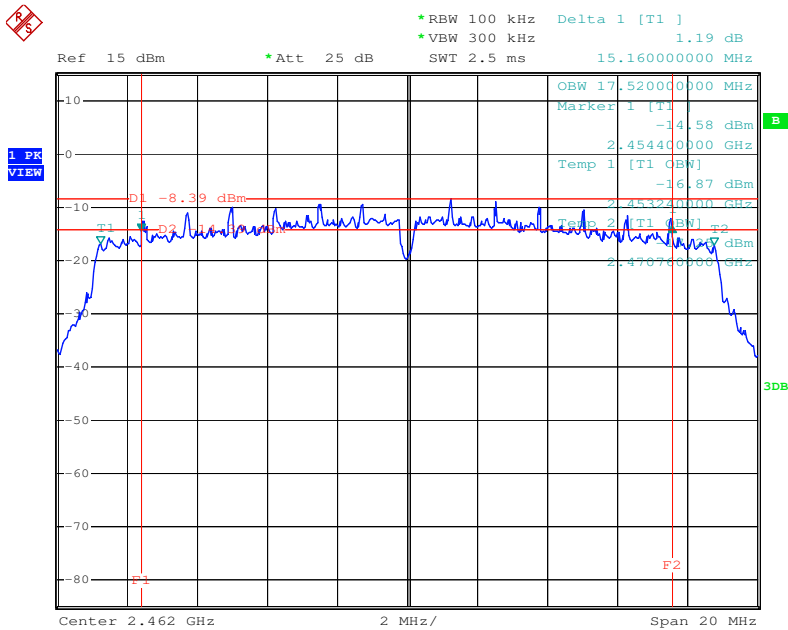

Date: 18.SEP.2016 12:53:55

801.11n(HT40) Mode ANT.1			
Frequency (MHz)	6dB Bandwidth (MHz)	99% OBW (MHz)	Limit
2422	35.200	35.68	≥500 kHz
2437	35.200	35.84	
2452	35.120	35.76	

N Mode 2422 MHz ANT.1

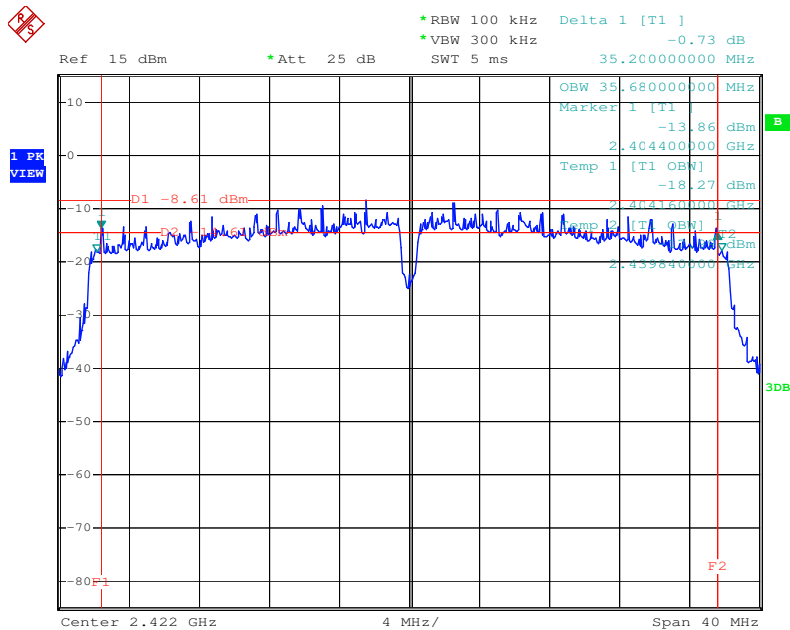

Date: 14.SEP.2016 13:41:28

N Mode 2437 MHz ANT. 1

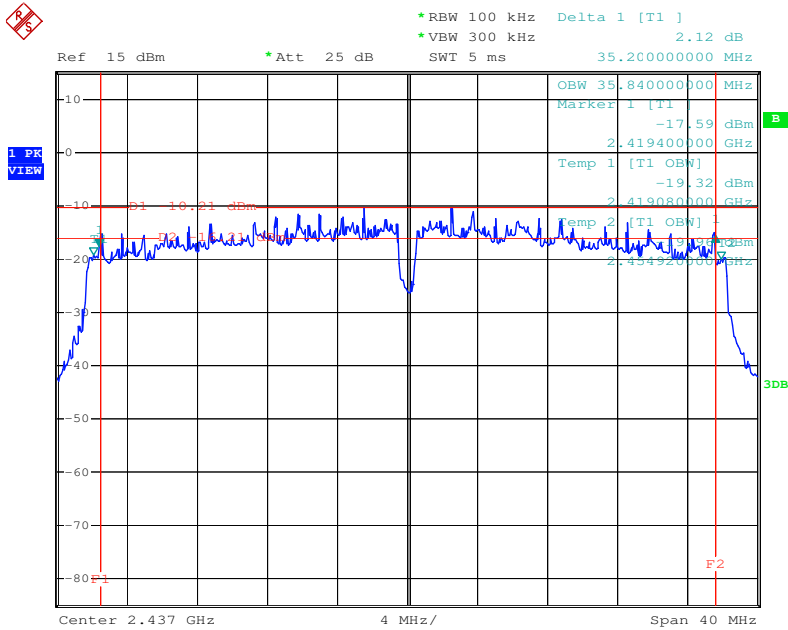

Date: 14.SEP.2016 13:35:56

N Mode 2452 MHz ANT. 1

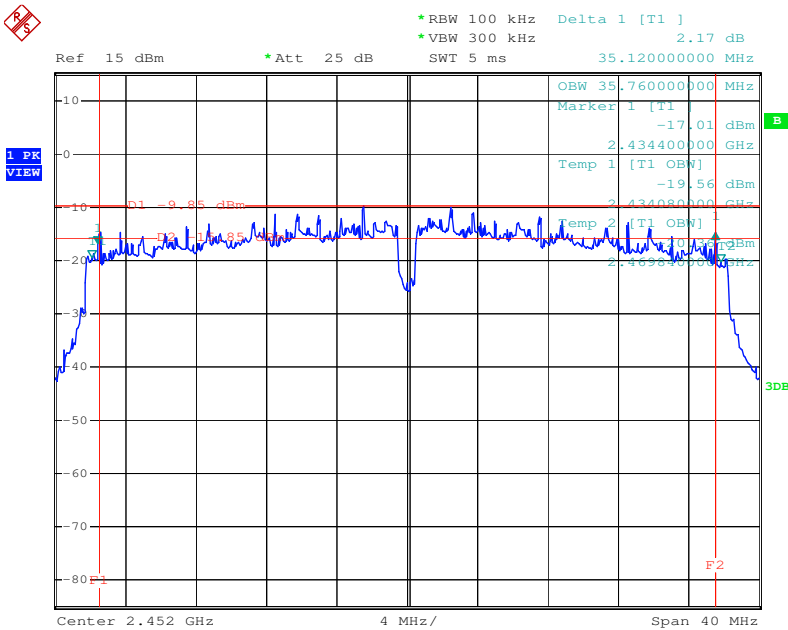

Date: 14.SEP.2016 13:33:53

N Mode 2437 MHz ANT. 2

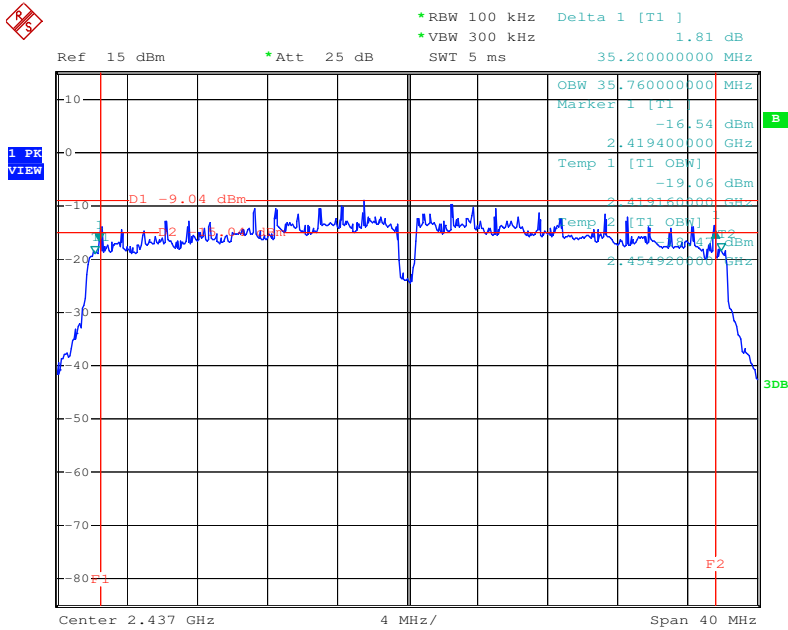

Date: 18.SEP.2016 13:01:56

N Mode 2452 MHz ANT. 2

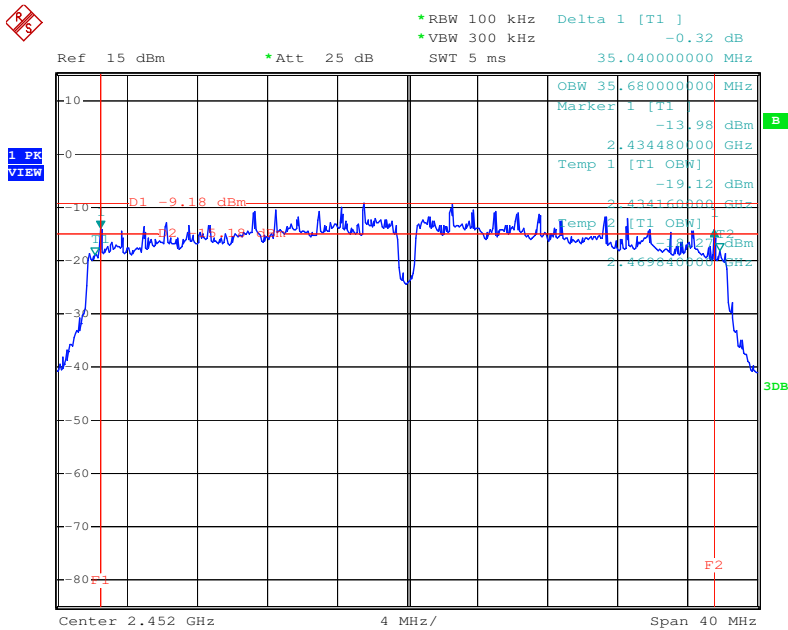

Date: 18.SEP.2016 13:03:11

6. POWER SPECTRAL DENSITY

6.1 LIMITS

FCC Part 15.247, Subpart C/ RSS 247Section 5.2(2)	
Frequency Range (MHz)	2400~2483.5
99% Occupied Bandwidth	8 dBm in any 3 kHz

6.2 TEST PROCEDURE

The EUT was directly connected to the power meter and antenna output port as show in the block diagram as bellow.

Spectrum Parameters	Setting
Attenuation	Auto
Span	Set the span to 1.5 times the DTS channel bandwidth
RBW	3 kHz
VBW	$\geq 3\text{RBW}$
Detector	Reak
Trace	Max Hold
Sweep Time	Auto

6.3 TEST SETUP

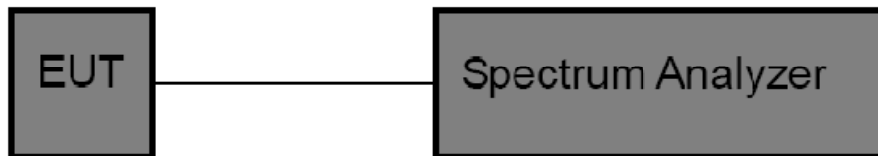

6.4 TEST INSTRUMENTS

Equipment	Manufacturer	Type No.	Serial No.	Last calibration	Calibrated until	Calibration period
Spectrum Analyzer	R&S	FSP40	100154	Jul. 04, 2015	Jul. 03. 2017	1 year

6.5 EUT OPERATING CONDITIONS

The EUT was set to continuously transmitting in the maximum power during the test.

6.6 TEST RESULTS

801.11b Mode					
Frequency (MHz)	Power Density (3 kHz/dBm)			Limit (dBm/3KHz)	Result
	ANT 1	ANT 2	Total		
2412	-7.24	-7.48	---	8	Pass
2437	-9.79	-8.82	---		
2462	-9.47	-9.91	---		

B Mode 2412 MHz-ANT 1

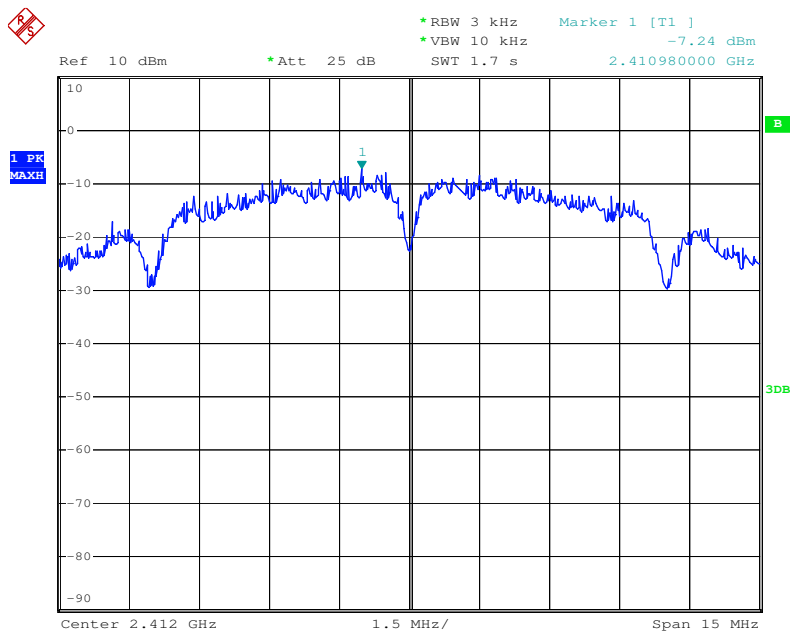

Date: 14.SEP.2016 15:53:01

B Mode 2412 MHz-ANT 2

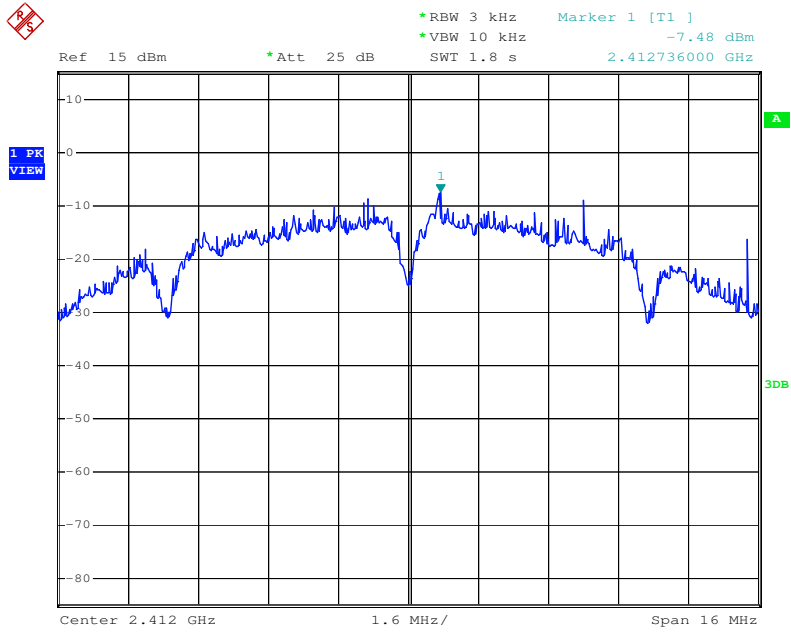

Date: 18.SEP.2016 13:09:35

B Mode 2437 MHz-ANT 2

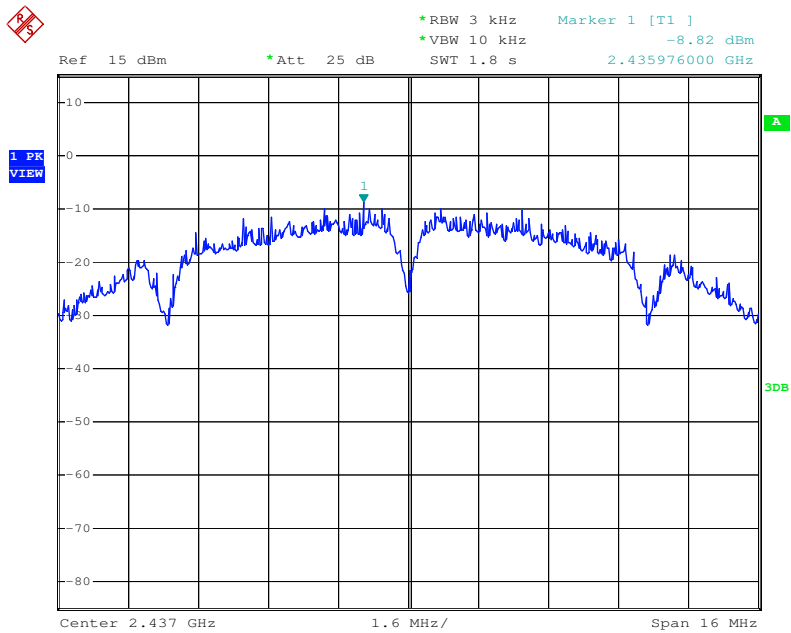

Date: 18.SEP.2016 13:12:22

B Mode 2462 MHz-ANT 2

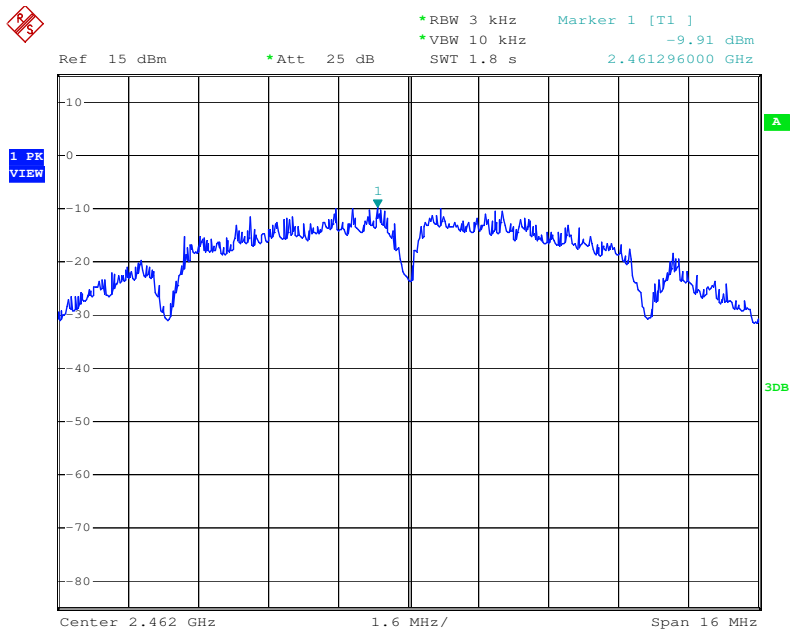

Date: 18.SEP.2016 13:12:53

801.11g Mode					
Frequency (MHz)	Power Density (3 kHz/dBm)			Limit (dBm/3KHz)	Result
	ANT 1	ANT 2	Total		
2412	-16.42	-15.62	---	8	Pass
2437	-15.42	-15.50	---		
2462	-13.67	-15.83	---		

G Mode 2412 MHz-ANT 1

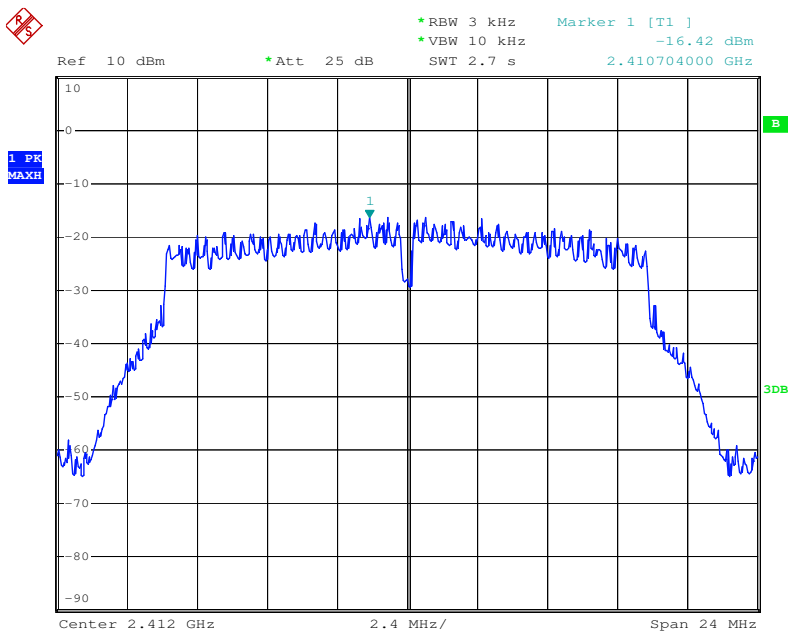

Date: 14.SEP.2016 15:42:59

G Mode 2437 MHz-ANT 1

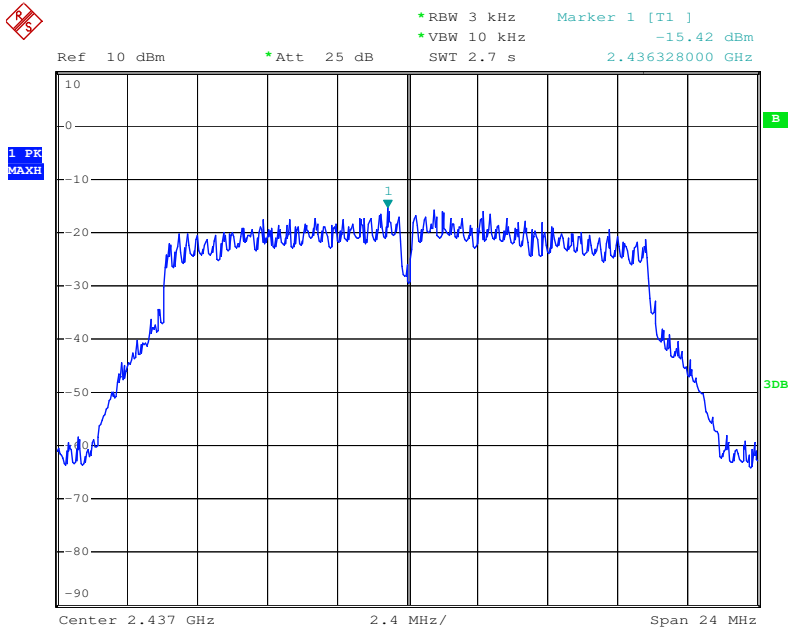

Date: 14.SEP.2016 15:43:24

G Mode 2462 MHz-ANT 1

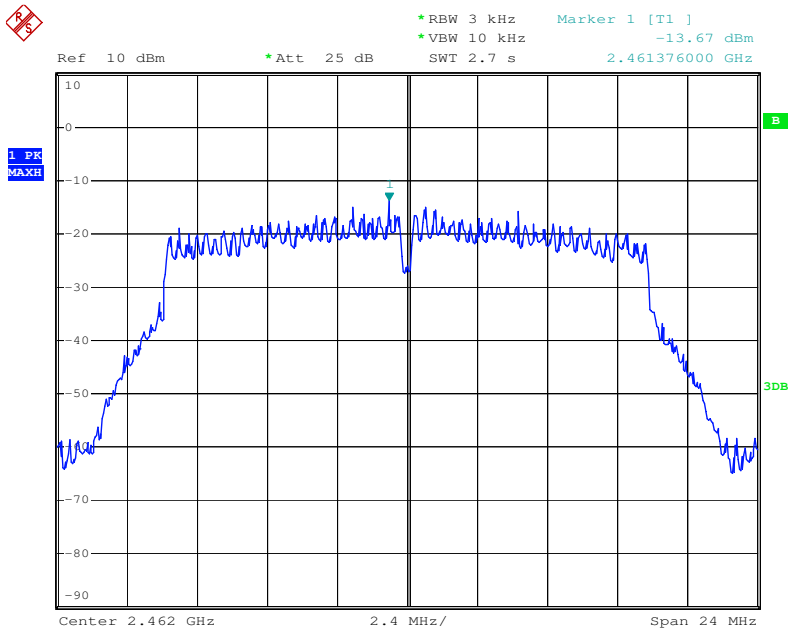

Date: 14.SEP.2016 15:43:53

G Mode 2412 MHz-ANT 2

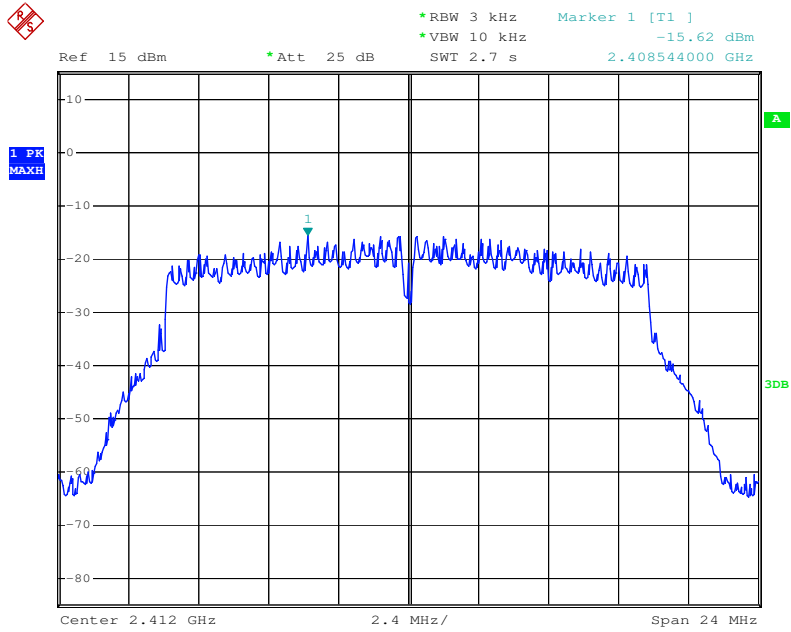

Date: 18.SEP.2016 13:18:15

G Mode 2437 MHz-ANT 2

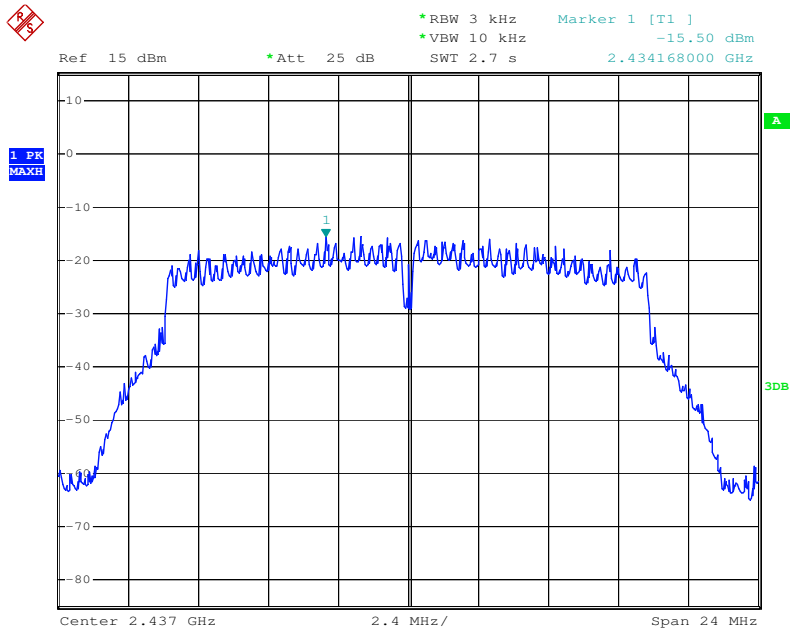

Date: 18.SEP.2016 13:17:42

G Mode 2462 MHz-ANT 2

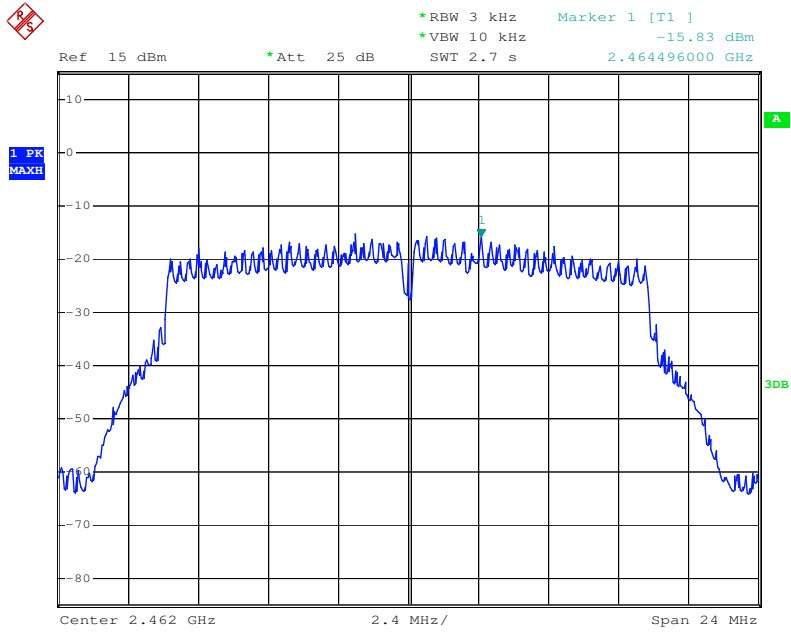

Date: 18.SEP.2016 13:17:07

801.11n(HT20) Mode					
Frequency (MHz)	Power Density (3 kHz/dBm)			Limit (dBm/3KHz)	Result
	ANT 1	ANT 2	Total		
2412	-23.70	-22.78	-20.205	8	Pass
2437	-23.58	-23.95	-20.751		
2462	-23.01	-23.41	-20.195		

N (HT20) Mode 2412 MHz-ANT 1

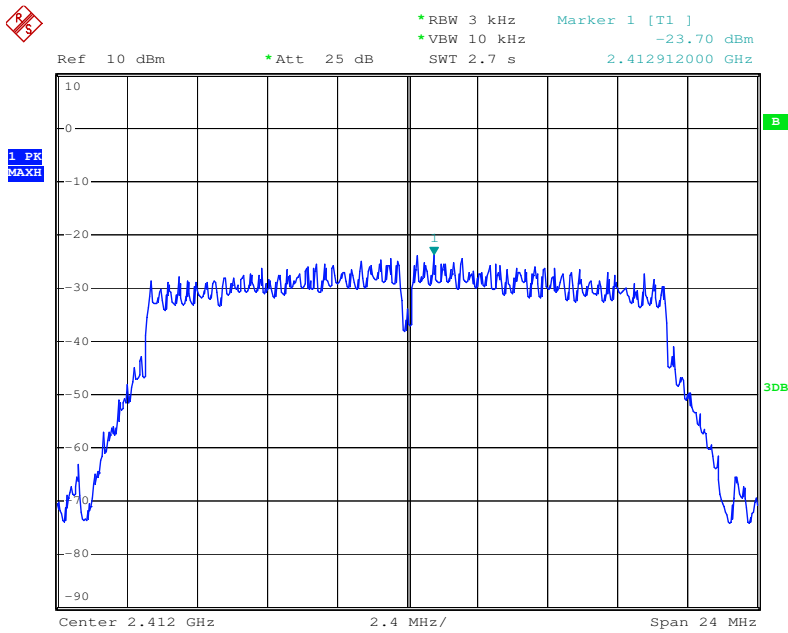

Date: 14.SEP.2016 15:44:33

N (HT20) 2437 MHz-ANT 1

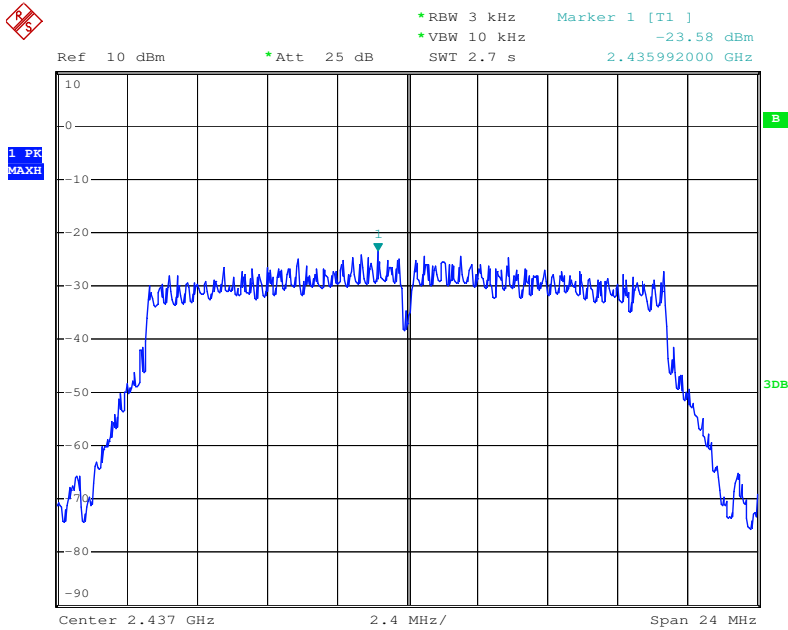

Date: 14.SEP.2016 15:44:51

N (HT20) 2462 MHz-ANT 1

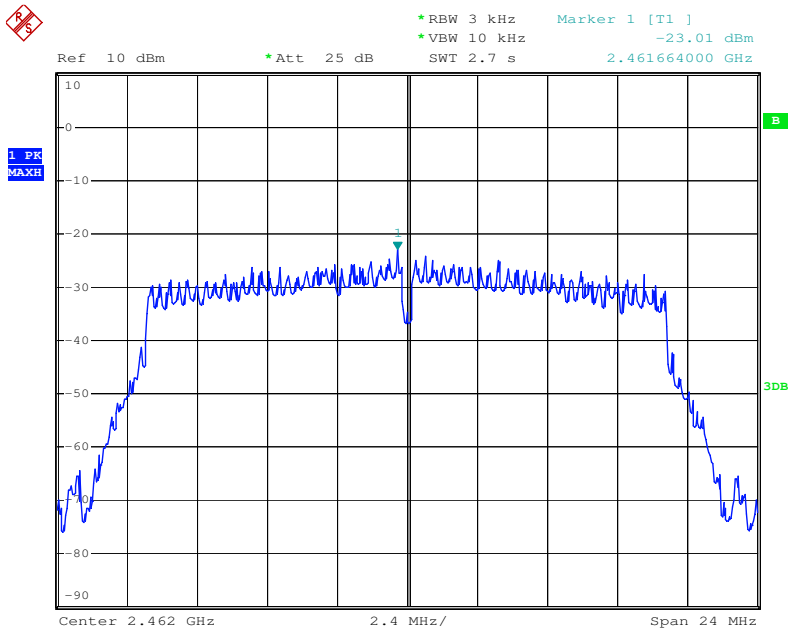

Date: 14.SEP.2016 15:45:10

N (HT20) Mode 2412 MHz-ANT 2

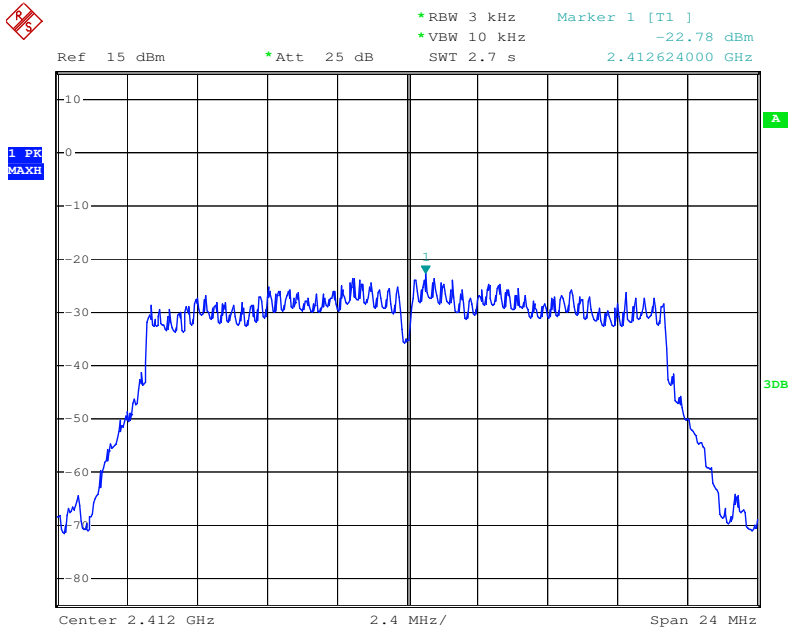

Date: 18.SEP.2016 13:21:49

N (HT20) 2437 MHz-ANT 2

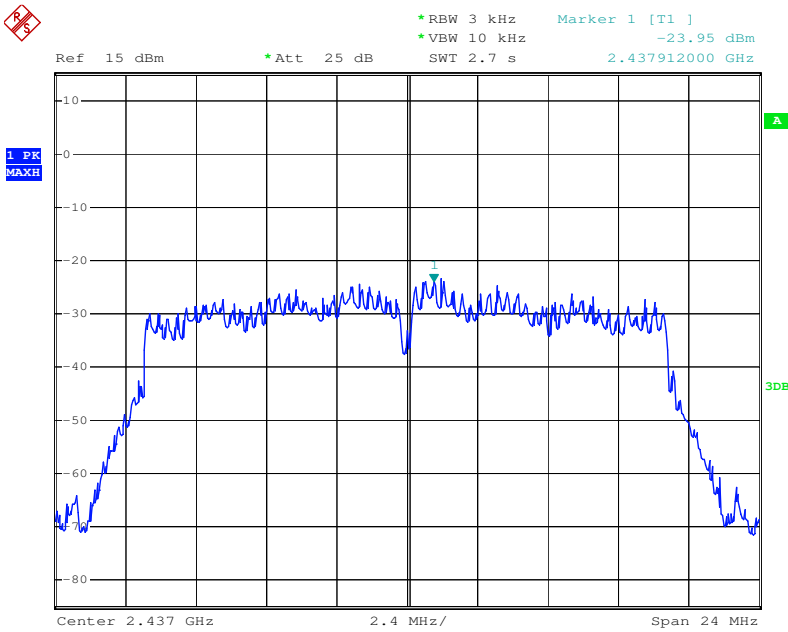

Date: 18.SEP.2016 13:22:27

N (HT20) 2462 MHz-ANT 2

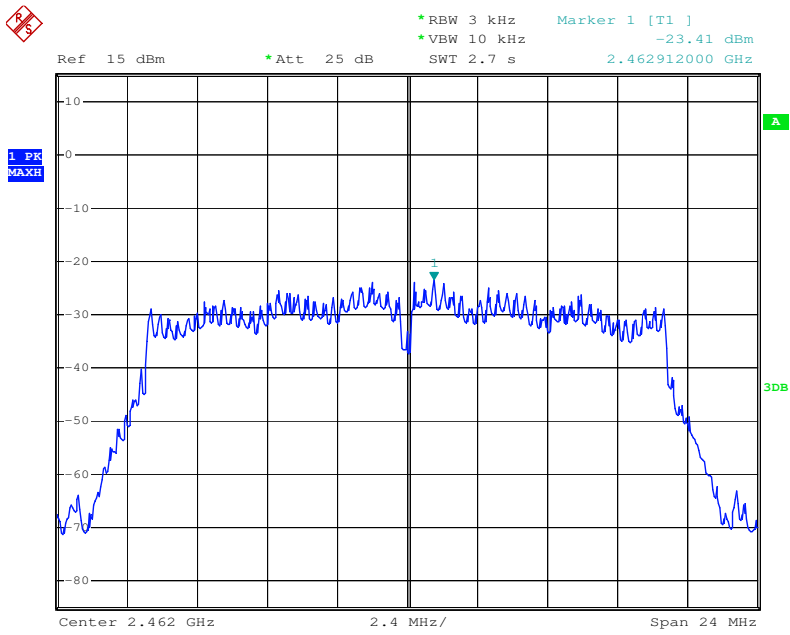

Date: 18.SEP.2016 13:23:08

801.11n(HT40) Mode					
Frequency (MHz)	Power Density (3 kHz/dBm)			Limit (dBm/3KHz)	Result
	ANT 1	ANT 2	Total		
2422	-24.96	-22.08	-20.275	8	Pass
2437	-25.32	-22.46	-20.648		
2452	-24.74	-25.65	-22.161		

N (HT40) Mode 2422 MHz-ANT 1

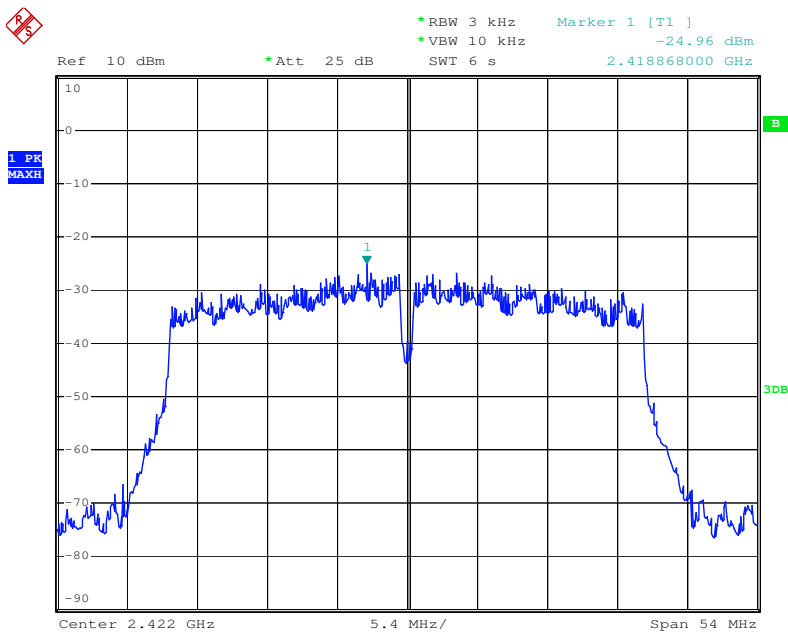

Date: 14.SEP.2016 15:45:54

N (HT40) 2437 MHz-ANT 1

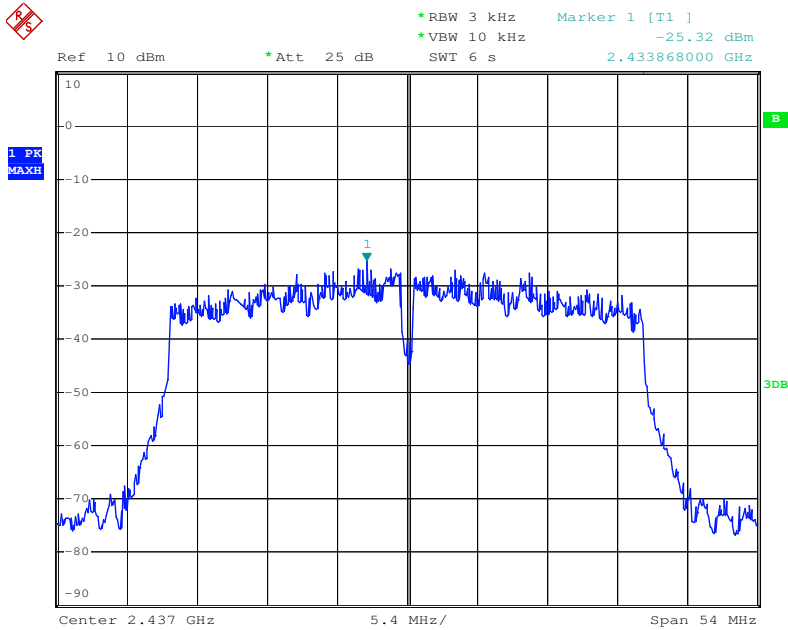

Date: 14.SEP.2016 15:46:20

N (HT40) 2452 MHz-ANT 1

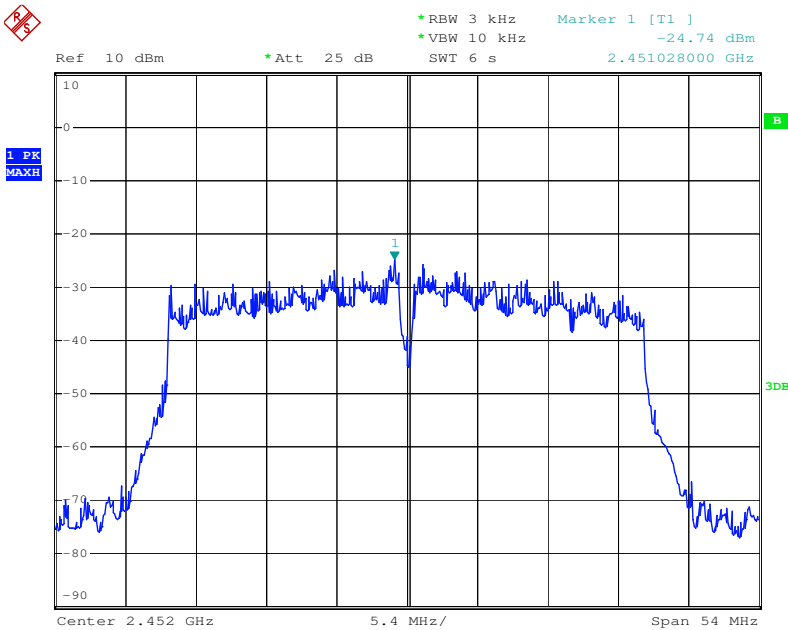

Date: 14.SEP.2016 15:46:47

N (HT40) Mode 2422 MHz-ANT 2

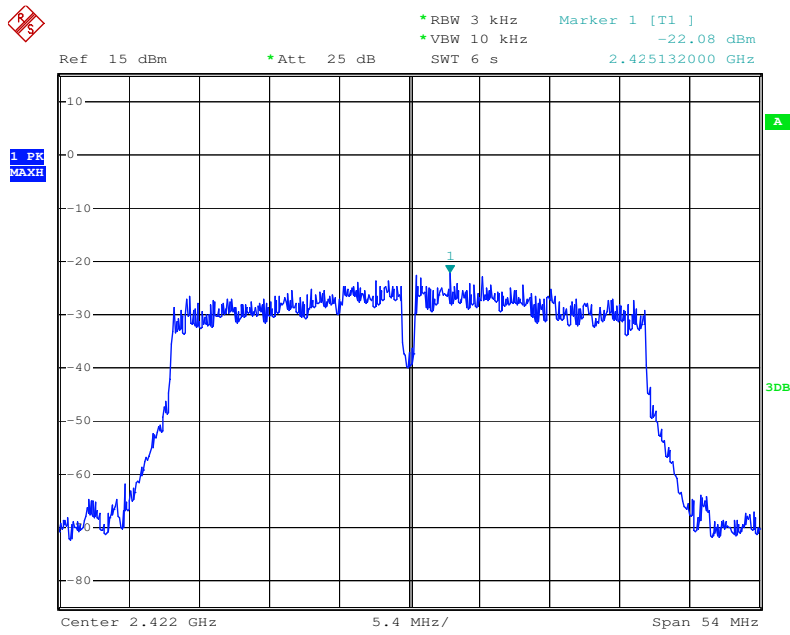

Date: 18.SEP.2016 13:30:09

N (HT40) 2437 MHz-ANT 2

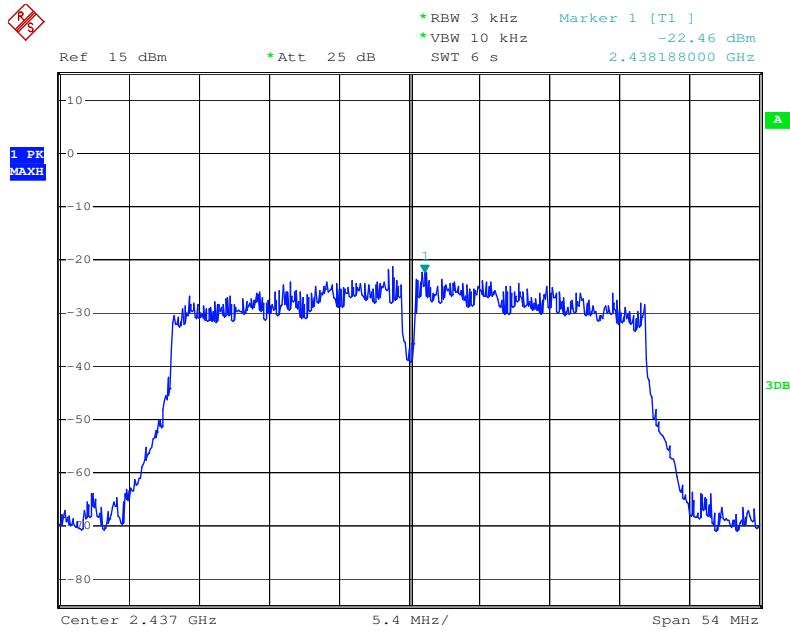

Date: 18.SEP.2016 13:29:08

N (HT40) 2452 MHz-ANT 1

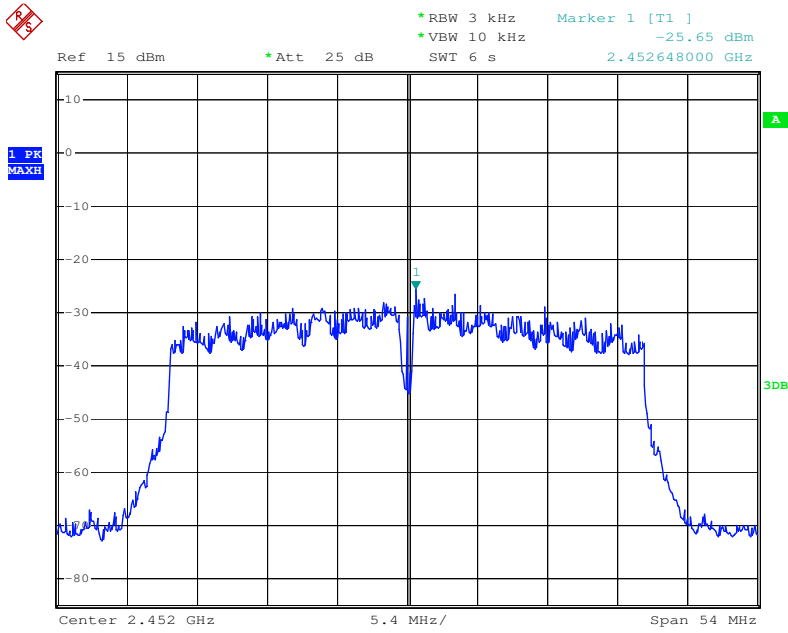

Date: 18.SEP.2016 13:27:03

7. BAND EDGE AND OUT-OF-BAND EMISSION

7.1 LIMITS

FCC Part 15.247, Subpart C/RSS 247 Section 5.5	
Frequency Range (MHz)	2400~2483.5
Limit	In any 100 kHz bandwidth outside the intentional radiation frequency band, the radio frequency power shall be at least 20 dB below the highest level of the desired power, based on either an RF conducted measurement, provide the transmitter demonstrates compliance with the peak conducted power limits.

7.2 TEST PROCEDURE

The EUT was directly connected to the power meter and antenna output port as shown in the block diagram as below.

- Set frequency range to capture low band-edge from 2310 MHz up to 2390 MHz, and for up band-edge from 2483.5 MHz up to 2500 MHz
- For low band-edge set the equipment transmit at the lowest channel, and for up band-edge set the equipment transmit at the highest channel
- Set the VBW ≥ 3 RBW (100kHz/ 300kHz) for conducted measurement
- For radiated measurements the RBW set to 1 MHz, and the VBW set to 1 MHz for peak measurements and 10 Hz for average measurement

7.3 TEST SETUP

(A) Radiated Emission Test Set-Up

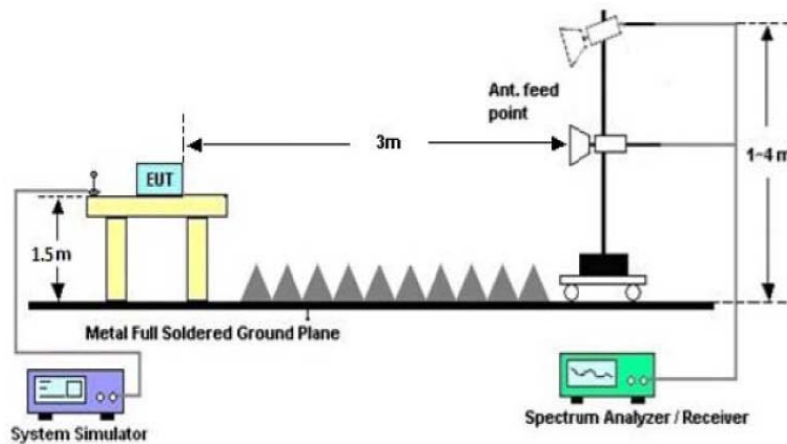

(B) Conducted Emission Test Setup

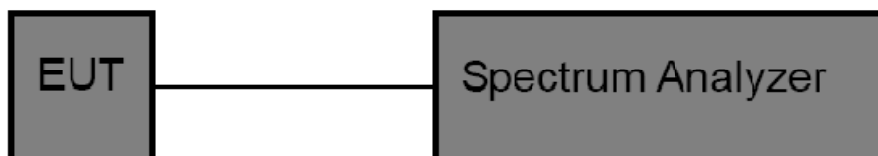

7.4 TEST INSTRUMENTS

Equipment	Manufacturer	Type No.	Serial No.	Last calibration	Calibrated until	Calibration period
Broadband Antenna	R&S	VULB 9168	VULB 9168-456	Jul. 04, 2016	Jul. 03. 2017	1 year
Test Cable	N/A	R-01	N/A	Jul. 04, 2016	Jul. 03. 2017	1 year
Test Cable	N/A	R-02	N/A	Jul. 04, 2016	Jul. 03. 2017	1 year
EMI Test Receiver	R&S	ESCI	101324	Jul. 04, 2016	Jul. 03. 2017	1 year
Spectrum Analyzer	Agilent	E4407B	MY41440432	Jul. 04, 2016	Jul. 03. 2017	1 year
Antenna Mast	EM	SC100_1	N/A	N/A	N/A	N/A
Turn Table	EM	SC100	060531	N/A	N/A	N/A
50Ω Switch	Anritsu Corp	MP59B	6200983705	Jul. 04, 2016	Jul. 03. 2017	1 year
Spectrum Analyzer	R&S	FSP40	100154	Jul. 04, 2016	Jul. 03. 2017	1 year
Horn Antenna	R&S	HF906	10029	Jul. 04, 2016	Jul. 03. 2017	1 year
Amplifier	EM	EM-30180	060538	Jul. 04, 2016	Jul. 03. 2017	1 year

7.5 EUT OPERATING CONDITIONS

The EUT was set to continuously transmitting in the maximum power during the test.

7.6 TEST RESULTS

Bandedge(Radiated Emission)

EUT :	WiFi Module	Model Name. :	W2CM2510
Temperature :	26 °C	Relative Humidity :	56%
Test Power :	DC 5V	Pressure :	1010 hPa
Test Mode :	TX B Mode Ant. 1	Test Date :	2016-09-14

Remark : Only show the worse case Antenna 1.

Freq.	Deceiver Reading	Detector	Polar	Corrected Factor	Emission Level	Limit	Margin
MHz	dBuV	Peak/Avg	H/V	dB	dBuV /m	dBuV /m	dB
Low Channel- 2412MHz							
2390	51.68	Peak	H	-3	48.68	74	-25.32
2390	39.68	Avg	H	-3	36.68	54	-17.32
2412	106.24	Peak	H	-3.12	103.12	Fundamental Frequency	
2412	101.46	Avg	H	-3.12	98.34	Fundamental Frequency	
2390	50.88	Peak	V	-3	47.88	74	-26.12
2390	38.98	Avg	V	-3	35.98	54	-18.02
2412	101.05	Peak	V	-3.12	97.93	Fundamental Frequency	
2412	95.53	Avg	V	-3.12	92.41	Fundamental Frequency	
High Channel- 2462MHz							
2462	98.53	Peak	H	-2.5	96.03	Fundamental Frequency	
2462	93.93	Avg	H	-2.5	91.43	Fundamental Frequency	
2483.5	48.18	Peak	H	-2.5	45.68	74	-28.32
2483.5	36.05	Avg	H	-2.5	33.55	54	-20.45
2462	96.92	Peak	V	-2.5	94.42	Fundamental Frequency	
2462	92.26	Avg	V	-2.5	89.76	Fundamental Frequency	
2483.5	48.05	Peak	V	-2.5	45.55	74	-28.45
2483.5	36.27	Avg	V	-2.5	33.77	54	-20.23

Remark:

Emission Level= Read Level+ Correct Factor

Margin= Emission Level-Limit

No report for the emission which more than 10 dB below the prescribed limit.

EUT :	WiFi Module	Model Name. :	W2CM2510
Temperature :	26 °C	Relative Humidity :	56%
Test Power :	DC 5V	Pressure :	1010 hPa
Test Mode :	TX G Mode Ant. 1	Test Date :	2016-09-14

Remark : Only show the worse case Antenna 1.

Freq.	Deceiver Reading	Detector	Polar	Corrected Factor	Emission Level	Limit	Margin
MHz	dBuV	Peak/Avg	H/V	dB	dBuV /m	dBuV /m	dB
Low Channel- 2412MHz							
2390	51.24	Peak	H	-3	48.24	74	-25.76
2390	39.55	Avg	H	-3	36.55	54	-17.45
2412	98.46	Peak	H	-3.12	95.34	Fundamental Frequency	
2412	87.54	Avg	H	-3.12	84.42	Fundamental Frequency	
2390	51.15	Peak	V	-3	48.15	74	-25.85
2390	39.65	Avg	V	-3	36.65	54	-17.35
2412	95.27	Peak	V	-3.12	92.15	Fundamental Frequency	
2412	85.76	Avg	V	-3.12	82.64	Fundamental Frequency	
High Channel- 2462MHz							
2462	97.26	Peak	H	-2.5	94.76	Fundamental Frequency	
2462	87.73	Avg	H	-2.5	85.23	Fundamental Frequency	
2483.5	49.85	Peak	H	-2.5	47.35	74	-26.65
2483.5	39.08	Avg	H	-2.5	36.58	54	-17.42
2462	95.02	Peak	V	-2.5	92.52	Fundamental Frequency	
2462	84.45	Avg	V	-2.5	81.95	Fundamental Frequency	
2483.5	49.77	Peak	V	-2.5	47.27	74	-26.73
2483.5	39.52	Avg	V	-2.5	37.02	54	-16.98

Remark:
 Emission Level= Read Level+ Correct Factor
 Margin= Emission Level-Limit
 No report for the emission which more than 10 dB below the prescribed limit.

EUT :	WiFi Module	Model Name. :	W2CM2510
Temperature :	26 °C	Relative Humidity :	56%
Test Power :	DC 5V	Pressure :	1010 hPa
Test Mode :	TX N20 Mode Ant. 1+2	Test Date :	2016-09-14

Remark : Only show the worse case.

Freq.	Deceiver Reading	Detector	Polar	Corrected Factor	Emission Level	Limit	Margin
MHz	dBuV	Peak/Avg	H/V	dB	dBuV /m	dBuV /m	dB
Low Channel- 2412MHz							
2390	49.66	Peak	H	-3	46.66	74	-27.34
2390	39.68	Avg	H	-3	36.68	54	-17.32
2412	94.46	Peak	H	-3.12	91.34	Fundamental Frequency	
2412	83.46	Avg	H	-3.12	80.34	Fundamental Frequency	
2390	50.65	Peak	V	-3	47.65	74	-26.35
2390	39.75	Avg	V	-3	36.75	54	-17.25
2412	93.79	Peak	V	-3.12	90.67	Fundamental Frequency	
2412	83.55	Avg	V	-3.12	80.43	Fundamental Frequency	
High Channel- 2462MHz							
2462	93.95	Peak	H	-2.5	91.45	Fundamental Frequency	
2462	84.13	Avg	H	-2.5	81.63	Fundamental Frequency	
2483.5	50.08	Peak	H	-2.5	47.58	74	-26.42
2483.5	40.08	Avg	H	-2.5	37.58	54	-16.42
2462	92.03	Peak	V	-2.5	89.53	Fundamental Frequency	
2462	82.82	Avg	V	-2.5	80.32	Fundamental Frequency	
2483.5	49.16	Peak	V	-2.5	46.66	74	-27.34
2483.5	37.86	Avg	V	-2.5	35.36	54	-18.64

Remark:

Emission Level= Read Level+ Correct Factor

Margin= Emission Level-Limit

No report for the emission which more than 10 dB below the prescribed limit.

EUT :	WiFi Module	Model Name. :	W2CM2510
Temperature :	26 °C	Relative Humidity :	56%
Test Power :	DC 5V	Pressure :	1010 hPa
Test Mode :	TX N40 Mode Ant. 1+2	Test Date :	2016-09-14

Remark : Only show the worse case.

Freq.	Deceiver Reading	Detector	Polar	Corrected Factor	Emission Level	Limit	Margin
MHz	dBuV	Peak/Avg	H/V	dB	dBuV /m	dBuV /m	dB
Low Channel- 2422MHz							
2390	51.35	Peak	H	-3	48.35	74	-25.65
2390	39.68	Avg	H	-3	36.68	54	-17.32
2422	93.35	Peak	H	-3.12	90.23	Fundamental Frequency	
2422	82.85	Avg	H	-3.12	79.73	Fundamental Frequency	
2390	49.77	Peak	V	-3	46.77	74	-27.23
2390	40.02	Avg	V	-3	37.02	54	-16.98
2422	92.46	Peak	V	-3.12	89.34	Fundamental Frequency	
2422	82.33	Avg	V	-3.12	79.21	Fundamental Frequency	
High Channel- 2452MHz							
2452	91.06	Peak	H	-2.5	88.56	Fundamental Frequency	
2452	81.06	Avg	H	-2.5	78.56	Fundamental Frequency	
2483.5	50.66	Peak	H	-2.5	48.16	74	-25.84
2483.5	39.05	Avg	H	-2.5	36.55	54	-17.45
2452	91.82	Peak	V	-2.5	89.32	Fundamental Frequency	
2452	81.82	Avg	V	-2.5	79.32	Fundamental Frequency	
2483.5	49.87	Peak	V	-2.5	47.37	74	-26.63
2483.5	38.16	Avg	V	-2.5	35.66	54	-18.34

Remark:

Emission Level= Read Level+ Correct Factor

Margin= Emission Level-Limit

No report for the emission which more than 10 dB below the prescribed limit.

Bandedge(Conducted Emission)

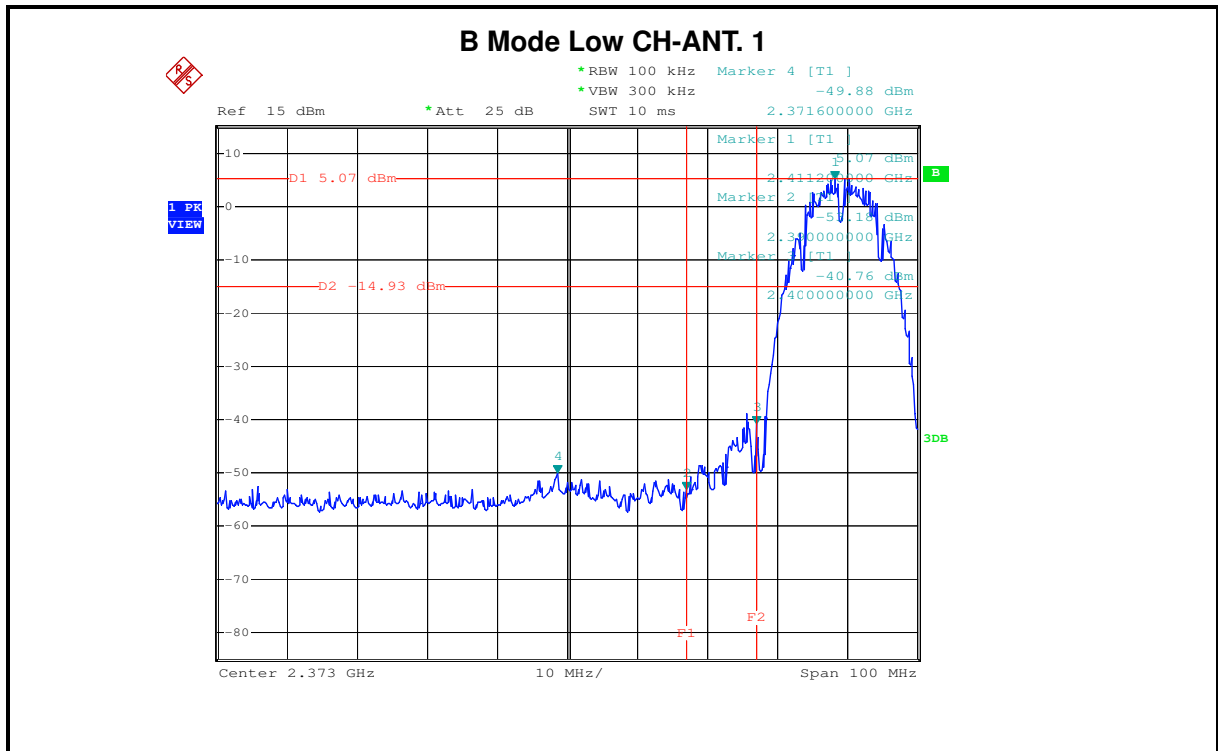

Date: 14.SEP.2016 16:03:01

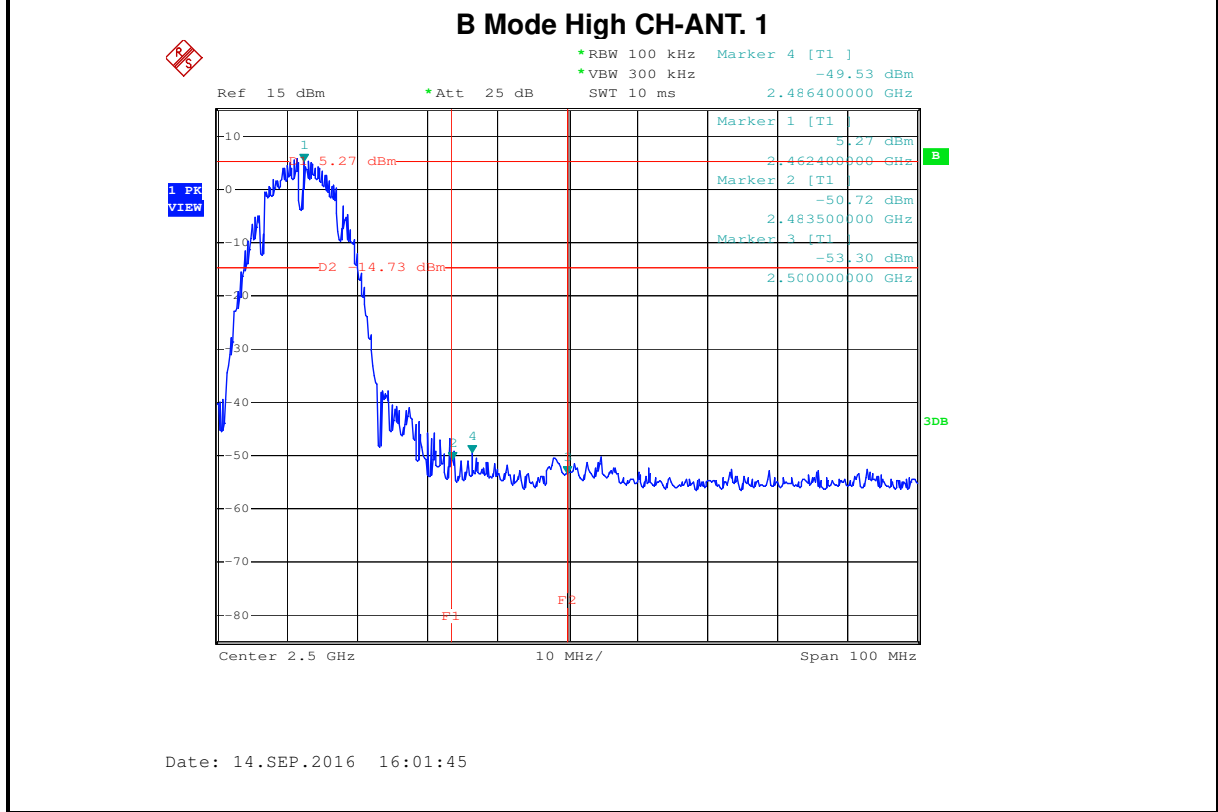

Date: 14.SEP.2016 16:01:45

B Mode Low CH-ANT. 2

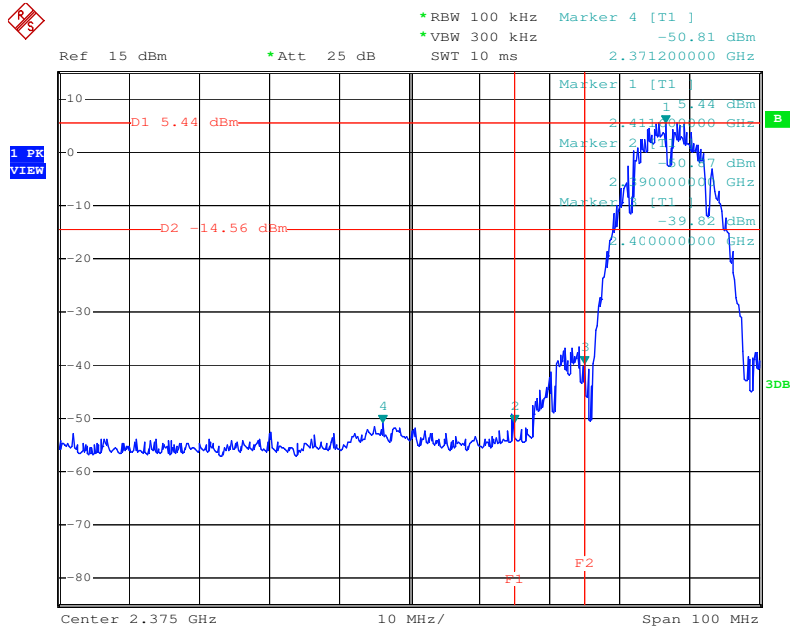

Date: 18.SEP.2016 13:11:36

B Mode High CH-ANT. 2

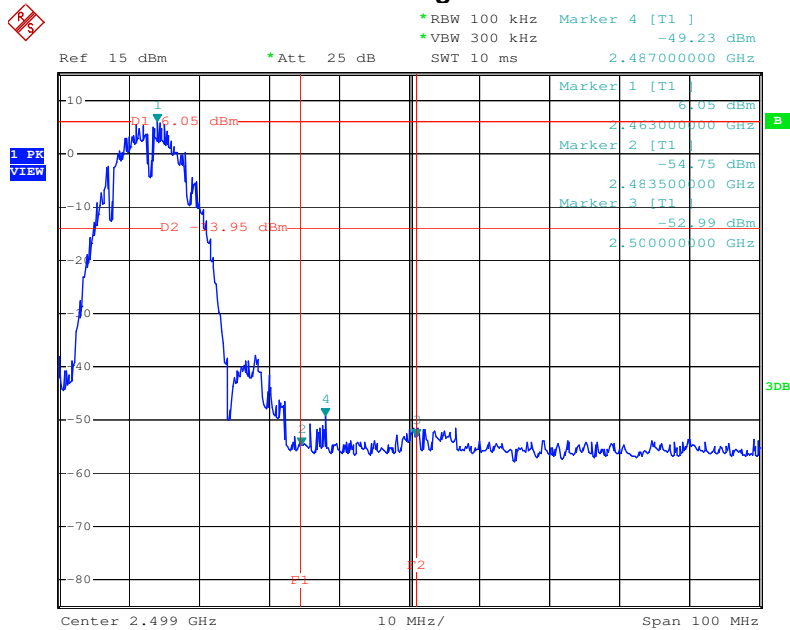

Date: 18.SEP.2016 13:13:52

G Mode Low CH-ANT. 1

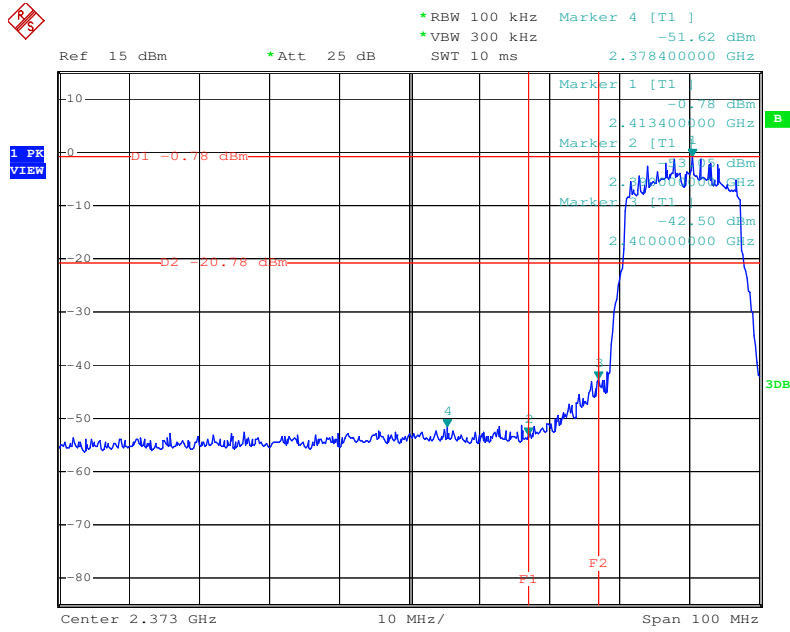

Date: 14.SEP.2016 16:04:44

G Mode High CH-ANT. 1

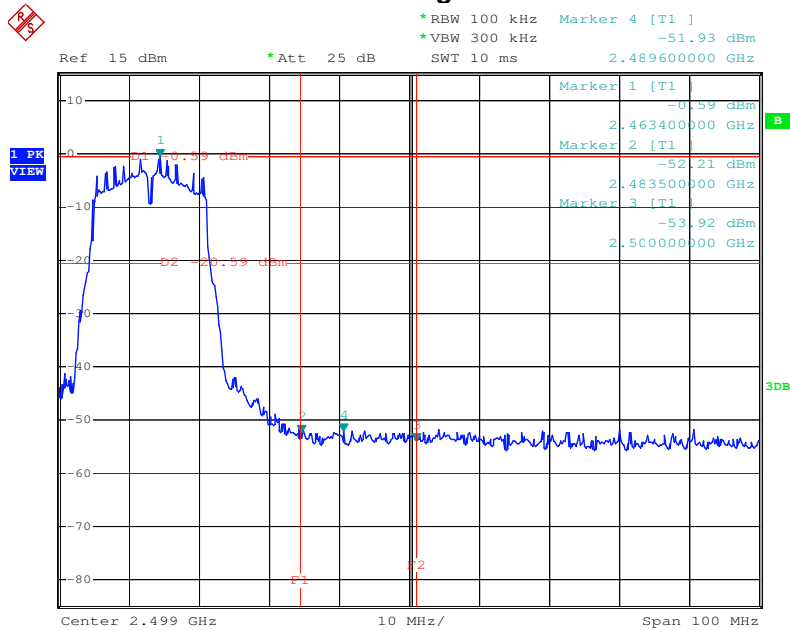

Date: 14.SEP.2016 16:06:19

G Mode Low CH-ANT. 2

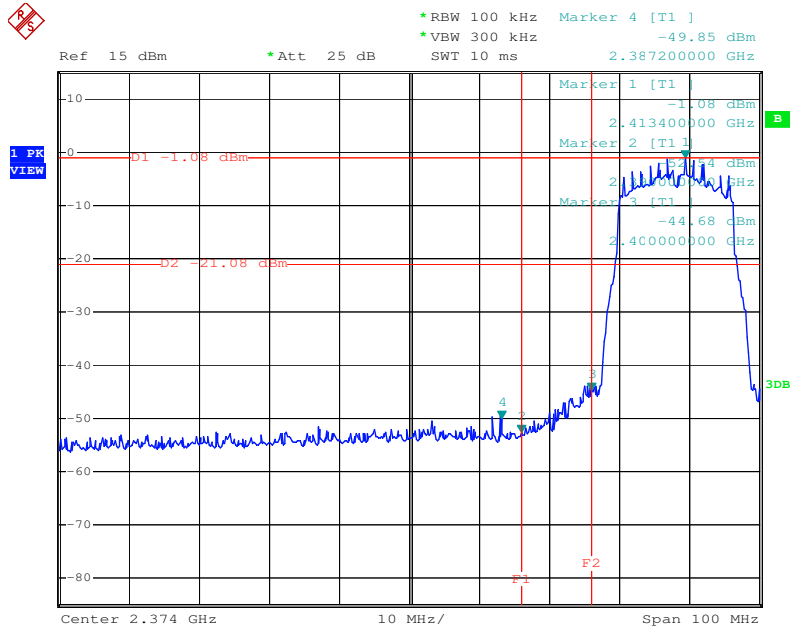

Date: 18.SEP.2016 13:19:15

G Mode High CH-ANT. 2

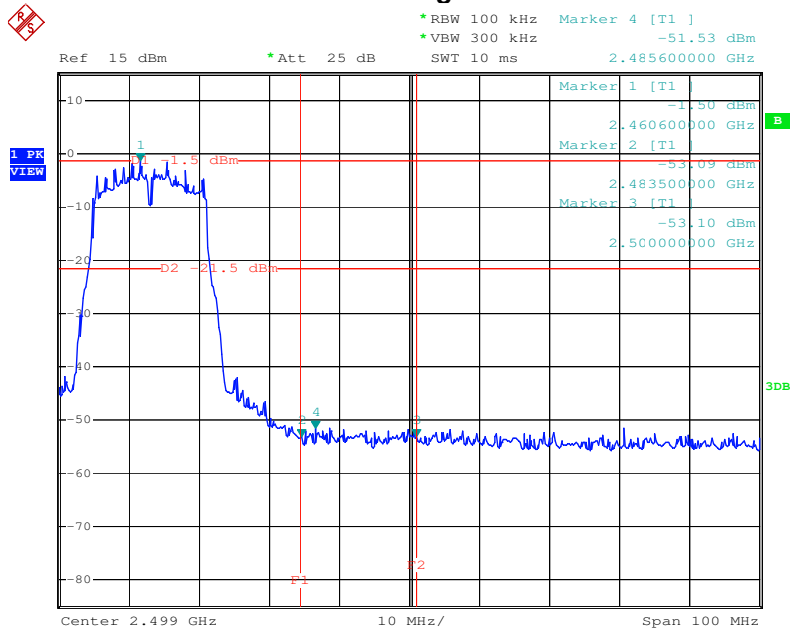

Date: 18.SEP.2016 13:15:06

N(20) Mode Low CH-ANT. 1

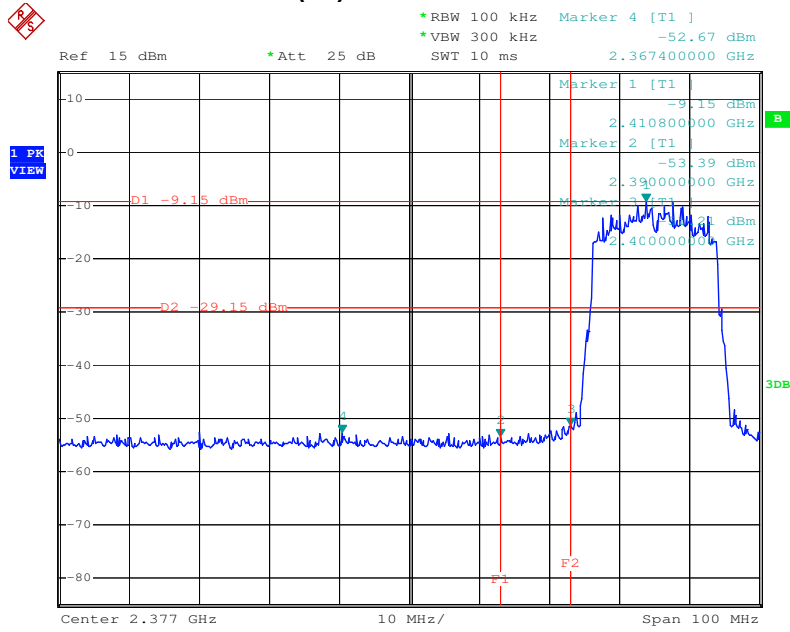

Date: 14.SEP.2016 16:10:32

N(20) Mode High CH-ANT. 1

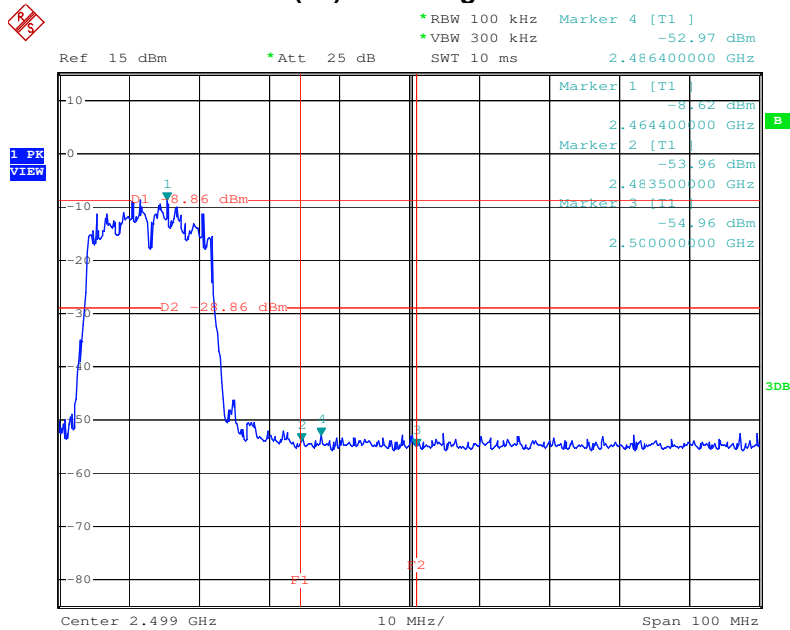

Date: 14.SEP.2016 16:08:25

N(20) Mode Low CH-ANT. 2

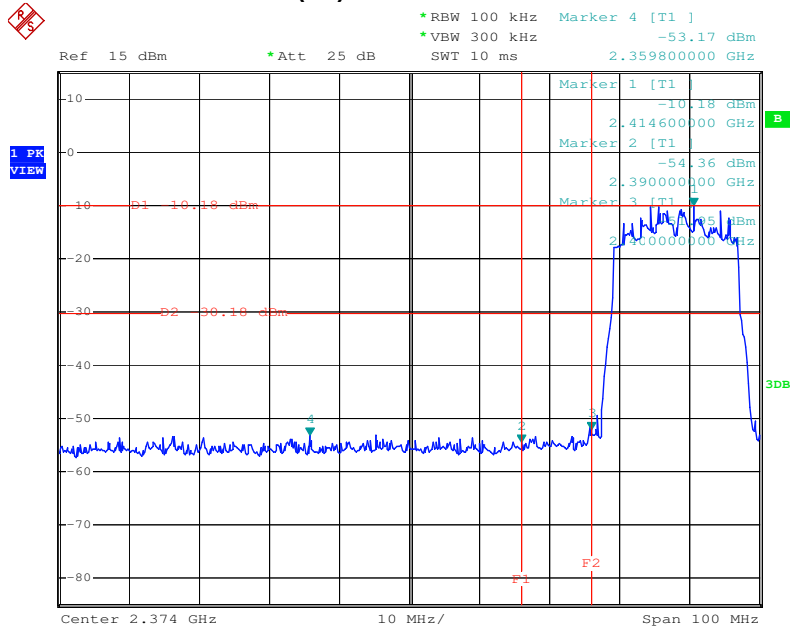

Date: 18.SEP.2016 13:20:47

N(20) Mode High CH-ANT. 2

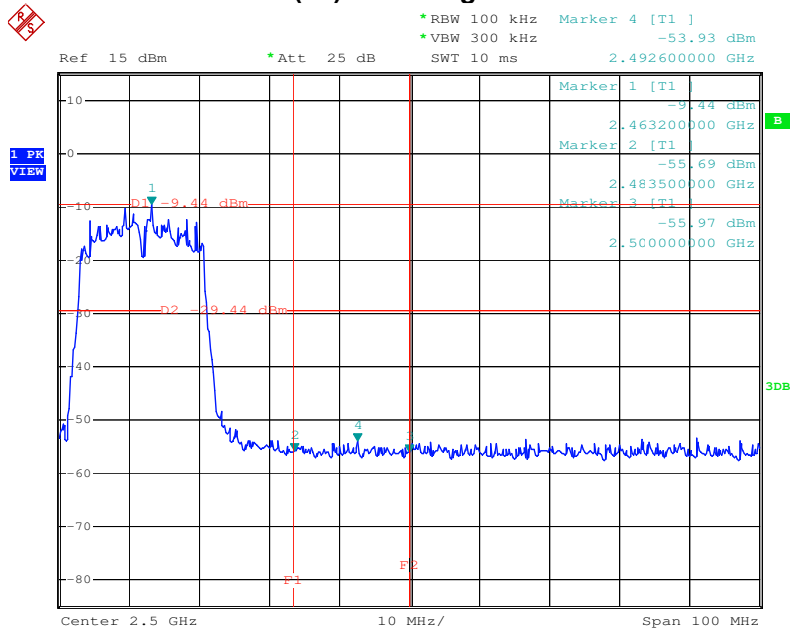

Date: 18.SEP.2016 13:24:25

N(40) Mode Low CH-ANT. 1

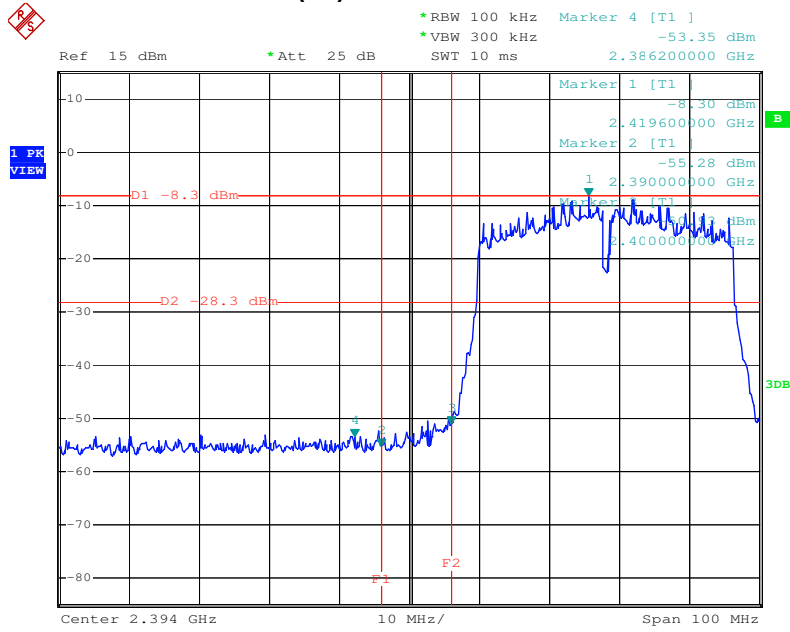

Date: 14.SEP.2016 16:25:36

N(40) Mode High CH-ANT. 1

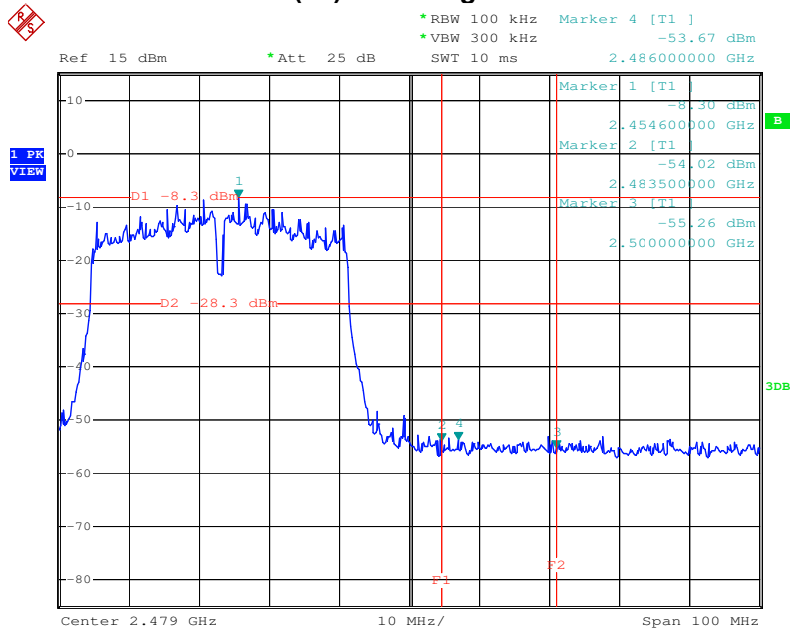

Date: 14.SEP.2016 16:26:49

N(40) Mode Low CH-ANT. 2

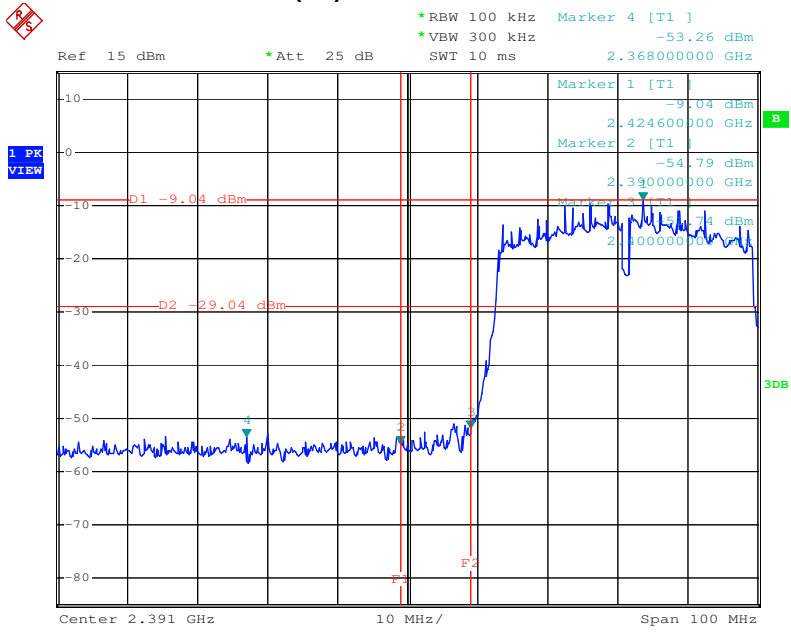

Date: 18.SEP.2016 13:31:20

N(40) Mode High CH-ANT. 2

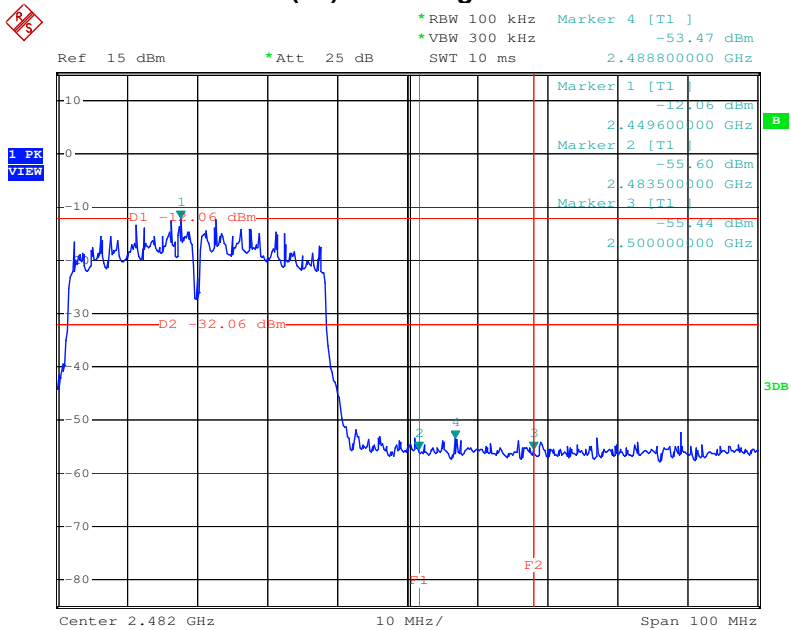

Date: 18.SEP.2016 13:26:27

8. ANTENNA REQUIREMENT

8.1 REQUIREMENT

Antenna Requirement (15.203)	An intentional radiator shall be designed to ensure that no antenna other than that furnished by the responsible party shall be used with the device. The use of a permanently attached antenna or of an antenna that uses a unique coupling to the intentional radiator shall be considered sufficient to comply with the provisions of this Section. The manufacturer may design the unit so that a broken antenna can be replaced by the user, but the use of a standard antenna jack or electrical connector is prohibited.
Antenna Requirement (15.247)	If transmitting antennas of directional gain greater than 6 dBi are used, the power shall be reduced by the amount in dB that the directional gain of the antenna exceeds 6 dBi.

8.2 ANTENNA CONNECTOR CONSTRUCTION

The EUT antenna is a PIFA Antenna. And the maximum gain of this antenna is 2.94dBi. It complies with the standard requirement.

-----END OF REPORT-----