

Company: Mimosa Networks

Test of: A5c, A5-14, A5-18

To: 15.407 (DFS Bands) & RSS-247, FCC 15B & ICES-003

Report No.: MIMO09-U8\_Master Rev A

**MASTER TEST REPORT**



# MASTER TEST REPORT

FROM



Test of: Mimosa Networks A5c, A5-14, A5-18

To: FCC 15.407 (DFS Bands) & RSS 247, FCC 15B & ICES-003

Test Report Serial No.: MIMO09-U8\_Master Rev A

This report supersedes: NONE

As a result of the 6 Mbyte FCC file size limitation potentially large test reports require to be split into smaller components. This document is the Master document controlling Addendum reports as listed below. This Master document combined with the Addendums demonstrate compliance with the standard

Master Document Number	Addendum Reports
MIMO09-U8_Master	MIMO09-U8_Conducted
	MIMO09-U8_Radiated
	MIMO09-U2_(FCC Part15B & ICES-003) A5c
	MIMO09-U3_(FCC Part15B & ICES-003) A5-14, A5-18

Applicant: Mimosa Networks  
469 El Camino Real, Suite 100  
Santa Clara, California 95050  
USA

Product Function: 4.9 - 5.8 GHz Wireless Access Point

Issue Date: 2<sup>nd</sup> August 2016

## This Test Report is Issued Under the Authority of:

**MiCOM Labs, Inc.**  
575 Boulder Court  
Pleasanton California 94566  
USA  
Phone: +1 (925) 462-0304  
Fax: +1 (925) 462-0306  
[www.micomlabs.com](http://www.micomlabs.com)



**MiCOM Labs is an ISO 17025 Accredited Testing Laboratory**



**Title:** Mimosa Networks A5c, A5-14, A5-18  
**To:** FCC 15.407 & RSS 247 (DFS Bands), FCC Part 15B & ICES-003  
**Serial #:** MIMO09-U8\_Master Rev A  
**Issue Date:** 2<sup>nd</sup> August 2016  
**Page:** 3 of 25

---

## Table of Contents

<b>1. ACCREDITATION, LISTINGS &amp; RECOGNITION.....</b>	<b>4</b>
1.1. Testing Accreditation .....	4
1.2. Recognition.....	5
1.3. Product Certification .....	6
<b>2. DOCUMENT HISTORY .....</b>	<b>7</b>
<b>3. TEST RESULT CERTIFICATE.....</b>	<b>8</b>
<b>4. REFERENCES AND MEASUREMENT UNCERTAINTY .....</b>	<b>9</b>
4.1. Normative References .....	9
4.2. Test and Uncertainty Procedure .....	10
<b>5. PRODUCT DETAILS AND TEST CONFIGURATIONS .....</b>	<b>11</b>
5.1. Technical Details .....	11
5.2. Scope Of Test Program .....	12
5.3. Equipment Model(s) and Serial Number(s) .....	15
5.4. Antenna Details .....	15
5.5. Cabling and I/O Ports .....	15
5.6. Test Configurations.....	16
5.7. Equipment Modifications .....	16
5.8. Deviations from the Test Standard .....	16
<b>6. TEST SUMMARY .....</b>	<b>17</b>
<b>7. TEST EQUIPMENT CONFIGURATION(S) .....</b>	<b>18</b>
7.1. Conducted .....	18
7.2. Radiated Spurious Emission Test Set-up > 1 GHz .....	20
7.3. DFS - Conducted .....	22
<b>8. MEASUREMENT AND PRESENTATION OF TEST DATA .....</b>	<b>24</b>

---

This test report may be reproduced in full only. The document may only be updated by MiCOM Labs personnel. All changes will be noted in the Document History section of the report.



**Title:** Mimosa Networks A5c, A5-14, A5-18  
**To:** FCC 15.407 & RSS 247 (DFS Bands), FCC Part 15B & ICES-003  
**Serial #:** MIMO09-U8\_Master Rev A  
**Issue Date:** 2<sup>nd</sup> August 2016  
**Page:** 4 of 25

## **1. ACCREDITATION, LISTINGS & RECOGNITION**

### **1.1. Testing Accreditation**

MiCOM Labs, Inc. is an accredited Electrical testing laboratory per the international standard ISO/IEC 17025:2005. The company is accredited by the American Association for Laboratory Accreditation (A2LA) [www.a2la.org](http://www.a2la.org) test laboratory number 2381.01. MiCOM Labs test schedule is available at the following URL; <http://www.a2la.org/scopepdf/2381-01.pdf>



This test report may be reproduced in full only. The document may only be updated by MiCOM Labs personnel. All changes will be noted in the Document History section of the report.



**Title:** Mimosa Networks A5c, A5-14, A5-18  
**To:** FCC 15.407 & RSS 247 (DFS Bands), FCC Part 15B & ICES-003  
**Serial #:** MIMO09-U8\_Master Rev A  
**Issue Date:** 2<sup>nd</sup> August 2016  
**Page:** 5 of 25

## 1.2. Recognition

MiCOM Labs, Inc has widely recognized wireless testing capabilities. Our international recognition includes Conformity Assessment Body designation by APEC MRA countries. MiCOM Labs test reports are accepted globally.

Country	Recognition Body	Status	Phase	Identification No.
USA	Federal Communications Commission (FCC)	TCB	-	US0159 Listing #: 102167
Canada	Industry Canada (IC)	FCB	APEC MRA 2	US0159 Listing #: 4143A-2 4143A-3
Japan	MIC (Ministry of Internal Affairs and Communication)	CAB	APEC MRA 2	RCB 210
	VCCI	--	--	A-0012
Europe	European Commission	NB	EU MRA	NB 2280
Australia	Australian Communications and Media Authority (ACMA)	CAB	APEC MRA 1	US0159
Hong Kong	Office of the Telecommunication Authority (OFTA)	CAB	APEC MRA 1	
Korea	Ministry of Information and Communication Radio Research Laboratory (RRL)	CAB	APEC MRA 1	
Singapore	Infocomm Development Authority (IDA)	CAB	APEC MRA 1	
Taiwan	National Communications Commission (NCC) Bureau of Standards, Metrology and Inspection (BSMI)	CAB	APEC MRA 1	
Vietnam	Ministry of Communication (MIC)	CAB	APEC MRA 1	

EU MRA – European Union Mutual Recognition Agreement.

NB – Notified Body

APEC MRA – Asia Pacific Economic Community Mutual Recognition Agreement. Recognition agreement under which test lab is accredited to regulatory standards of the APEC member countries.

Phase I - recognition for product testing

Phase II – recognition for both product testing and certification

This test report may be reproduced in full only. The document may only be updated by MiCOM Labs personnel. All changes will be noted in the Document History section of the report.



**Title:** Mimosa Networks A5c, A5-14, A5-18  
**To:** FCC 15.407 & RSS 247 (DFS Bands), FCC Part 15B & ICES-003  
**Serial #:** MIMO09-U8\_Master Rev A  
**Issue Date:** 2<sup>nd</sup> August 2016  
**Page:** 6 of 25

### 1.3. Product Certification

MiCOM Labs, Inc. is an accredited Product Certification Body per the international standard ISO/IEC 17065:2012. The company is accredited by the American Association for Laboratory Accreditation (A2LA) [www.a2la.org](http://www.a2la.org) test laboratory number 2381.02. MiCOM Labs test schedule is available at the following URL; <http://www.a2la.org/scopepdf/2381-02.pdf>



United States of America – Telecommunication Certification Body (TCB)  
Industry Canada – Certification Body, CAB Identifier – US0159  
Europe – Notified Body (NB), NB Identifier - 2280  
Japan – Recognized Certification Body (RCB), RCB Identifier - 210

This test report may be reproduced in full only. The document may only be updated by MiCOM Labs personnel. All changes will be noted in the Document History section of the report.



**Title:** Mimosa Networks A5c, A5-14, A5-18  
**To:** FCC 15.407 & RSS 247 (DFS Bands), FCC Part 15B & ICES-003  
**Serial #:** MIMO09-U8\_Master Rev A  
**Issue Date:** 2<sup>nd</sup> August 2016  
**Page:** 7 of 25

## 2. DOCUMENT HISTORY

Draft History		
Revision	Date	Comments
Draft	29 <sup>th</sup> June 2016	
Draft #2	19 <sup>th</sup> July 2016	

Released Document History				
Master		Addendum Revision	Date	Comments
Revision	Date			
Rev A	2 <sup>nd</sup> August 2016	Conducted Rev A	2 <sup>nd</sup> August 2016	Initial Release
		Radiated Rev A	2 <sup>nd</sup> August 2016	
		Part 15B Rev A (A5c)	26 <sup>th</sup> July 2016	
		Part 15B Rev A (A5)	26 <sup>th</sup> July 2016	

In the above table the latest report revision will replace all earlier versions.

This test report may be reproduced in full only. The document may only be updated by MiCOM Labs personnel. All changes will be noted in the Document History section of the report.



**Title:** Mimosa Networks A5c, A5-14, A5-18  
**To:** FCC 15.407 & RSS 247 (DFS Bands), FCC Part 15B & ICES-003  
**Serial #:** MIMO09-U8\_Master Rev A  
**Issue Date:** 2<sup>nd</sup> August 2016  
**Page:** 8 of 25

### 3. TEST RESULT CERTIFICATE

<b>Manufacturer:</b> Mimosa Networks 469 El Camino Real, Suite 100 Santa Clara, California 95050 USA	<b>Tested By:</b> MiCOM Labs, Inc. 575 Boulder Court Pleasanton California 94566 USA
<b>Model:</b> A5c, A5-14, A5-18 <b>Equipment Type:</b> 802.11 a/n/ac Wireless Access Point	<b>Telephone:</b> +1 925 462 0304 <b>Fax:</b> +1 925 462 0306
<b>S/N's:</b> A5-14: 2112696984 A5-18: 2119591877 A5c: 2115237991 (DFS)	
<b>Test Date(s):</b> 23 <sup>rd</sup> – 29 <sup>th</sup> June 2016	<b>Website:</b> www.micomlabs.com

STANDARD(S)	TEST RESULTS
FCC CFR 47 Part 15 Subpart E 15.407 & IC RSS 247(DFS Bands), FCC Part 15B & ICES-003	EQUIPMENT COMPLIES

MiCOM Labs, Inc. tested the equipment mentioned in accordance with the requirements set forth in the above standards. Test results indicate that the equipment tested is capable of demonstrating compliance with the requirements as documented within this report.

**Notes:**

1. This document reports conditions under which testing was conducted and the results of testing performed.
2. Details of test methods used have been recorded and kept on file by the laboratory.
3. Test results apply only to the item(s) tested.

**Approved & Released for MiCOM Labs, Inc. by:**



\_\_\_\_\_  
Graeme Grieve  
Quality Manager MiCOM Labs, Inc.

\_\_\_\_\_  
Gordon Hurst  
President & CEO MiCOM Labs, Inc.

This test report may be reproduced in full only. The document may only be updated by MiCOM Labs personnel. All changes will be noted in the Document History section of the report.





**Title:** Mimosa Networks A5c, A5-14, A5-18  
**To:** FCC 15.407 & RSS 247 (DFS Bands), FCC Part 15B & ICES-003  
**Serial #:** MIMO09-U8\_Master Rev A  
**Issue Date:** 2<sup>nd</sup> August 2016  
**Page:** 9 of 25

## 4. REFERENCES AND MEASUREMENT UNCERTAINTY

### 4.1. Normative References

REF.	PUBLICATION	YEAR	TITLE
I	KDB 662911 D01 & D02	Oct 31 2013	Guidance for measurement of output emission of devices that employ single transmitter with multiple outputs or systems with multiple transmitters operating simultaneously in the same frequency band
II	KDB 905462 D07 v01r01	8th April 2016	Test guidance to demonstrate compliance for U-NII devices subject to DFS requirements.
III	KDB 926956 D01 v01r06	8th April 2016	U-NII Device Transition Plan
IV	KDB 789033 D02 v01r02	8th April 2016	General UNII Test Procedures New Rules
V	A2LA	June 2015	R105 - Requirement's When Making Reference to A2LA Accreditation Status
VI	ANSI C63.10	2013	American National Standard for Testing Unlicensed Wireless Devices
VII	ANSI C63.4	2014	American National Standards for Methods of Measurement of Radio-Noise Emissions from Low-Voltage Electrical and Electronic Equipment in the Range of 9 kHz to 40 GHz
VIII	CISPR 22	2008	Information technology equipment - Radio disturbance characteristics - Limits and methods of measurement
IX	ETSI TR 100 028	2001-12	Parts 1 and 2 Electromagnetic compatibility and Radio Spectrum Matters (ERM); Uncertainties in the measurement of mobile radio equipment characteristics
X	FCC 06-96	Jun 30 2006	Memorandum Opinion and Order
XI	FCC 47 CFR Part 15.407	2014	Radio Frequency Devices; Subpart E –Unlicensed National Information Infrastructure Devices
XII	ICES-003	Issue 6 Jan 2016	Spectrum Management and Telecommunications; Interference-Causing Equipment Standard. Information Technology Equipment (Including Digital Apparatus) – Limits and methods of measurement.
XIII	M 3003	Edition 3 Nov.2012	Expression of Uncertainty and Confidence in Measurements
XIV	RSS-247 Issue 1	May 2015	Digital Transmission Systems (DTSS), Frequency Hopping System (FHSs) and Licence-Exempt Local Area Network (LE-LEN) Devices
XV	RSS-Gen Issue 4	November 2014	General Requirements and Information for the Certification of Radiocommunication Equipment
XVI	KDB 644545 D03 v01	August 14th 2014	Guidance for IEEE 802.11ac New Rules
XVII	FCC 47 CFR Part 2.1033	2014	FCC requirements and rules regarding photographs and test setup diagrams.
XVIII	EN 55022	2010 + AC:2011	Information technology equipment - Radio disturbance characteristics - Limits and methods of measurement

This test report may be reproduced in full only. The document may only be updated by MiCOM Labs personnel. All changes will be noted in the Document History section of the report.



**Title:** Mimosa Networks A5c, A5-14, A5-18  
**To:** FCC 15.407 & RSS 247 (DFS Bands), FCC Part 15B & ICES-003  
**Serial #:** MIMO09-U8\_Master Rev A  
**Issue Date:** 2<sup>nd</sup> August 2016  
**Page:** 10 of 25

---

#### **4.2. Test and Uncertainty Procedure**

Conducted and radiated emission measurements were conducted in accordance with American National Standards Institute ANSI C63.4, listed in the Normative References section of this report.

Measurement uncertainty figures are calculated in accordance with ETSI TR 100 028 Parts 1 and 2.

Measurement uncertainties stated are based on a standard uncertainty multiplied by a coverage factor  $k = 2$ , providing a level of confidence of approximately 95 % in accordance with UKAS document M 3003 listed in the Normative References section of this report.

---

This test report may be reproduced in full only. The document may only be updated by MiCOM Labs personnel. All changes will be noted in the Document History section of the report.



**Title:** Mimosa Networks A5c, A5-14, A5-18  
**To:** FCC 15.407 & RSS 247 (DFS Bands), FCC Part 15B & ICES-003  
**Serial #:** MIMO09-U8\_Master Rev A  
**Issue Date:** 2<sup>nd</sup> August 2016  
**Page:** 11 of 25

## 5. PRODUCT DETAILS AND TEST CONFIGURATIONS

### 5.1. Technical Details

Details	Description
Purpose:	Test of the Mimosa Networks A5c, A5-14, A5-18 to FCC CFR 47 Part 15 Subpart E 15.407 & IC RSS 247 (DFS Bands)
Applicant:	Mimosa Networks 469 El Camino Real, Suite 100 Santa Clara, California 95050
Manufacturer:	As Applicant
Laboratory performing the tests:	MiCOM Labs, Inc. 575 Boulder Court Pleasanton California 94566 USA
Test report reference number:	MIMO09-U8_Master
Date EUT received:	23 <sup>rd</sup> June 2016
Standard(s) applied:	FCC CFR 47 Part 15 Subpart E 15.407 & IC RSS-247
Dates of test (from - to):	23 <sup>rd</sup> -29 <sup>th</sup> June 2016
No of Units Tested:	1
Type of Equipment:	802.11 a/n/ac Wireless Access Point
Product Family Name:	A5
Model(s):	A5c, A5-14, A5-18
Location for use:	Outdoor
Declared Frequency Range(s):	5250 – 5350, 5470 - 5725 MHz;
Primary function of equipment:	4.9 – 5.8 GHz Wireless Access Point
Secondary function of equipment:	None Provided
Type of Modulation:	OFDM
EUT Modes of Operation:	802.11n ac-20; 802.11n ac-40; 802.11n-ac80
Transmit/Receive Operation:	Transceiver - Half Duplex
Rated Input Voltage and Current:	POE (POE adaptor sold with unit) 55Vdc
Operating Temperature Range:	Declared Range -40°C to +55°C
ITU Emission Designator:	802.11ac-20: 17M8D1D 802.11ac-40: 36M7D1D 802.11ac-80: 77M0D1D
Equipment Dimensions:	A5c: Height 300 mm x Length 151 mm A5-14: Height 321 mm x Length 142 mm A5-18: Height 643 mm x Length 142 mm
Weight:	A5c: 4 lbs A5-14: 4 lbs A5-18: 8 lbs
Hardware Rev:	D
Software Rev:	2.0

This test report may be reproduced in full only. The document may only be updated by MiCOM Labs personnel. All changes will be noted in the Document History section of the report.

## **5.2. Scope Of Test Program**

### **Mimosa Networks A5c, A5-14, A5-18**

The scope of the test program was to test the Mimosa Networks 802.11ac, configurations in the frequency ranges 5250 - 5350 MHz; 5470 - 5725 MHz; for compliance against the following specification:

#### **FCC CFR 47 Part 15 Subpart E 15.407**

Radio Frequency Devices; Subpart E – Unlicensed National Information Infrastructure Devices

#### **Industry Canada RSS-247 (Issue 1)**

Digital Transmission Systems (DTSS), Frequency Hopping System (FHSs) and License-Exempt Local Area Network (LE-LEN) Devices

#### **Product Family**

A5-14 : Integral Antennas (see Section 5.4 Antenna Details for antenna)

A5-18 : Integral Antenna (see Section 5.4 Antenna Details for integral antenna gain)

A5c : External Antenna (see Section 5.4 Antenna Details for integral antenna and beam-forming gains)

### **Mimosa Networks A5-14**



---

This test report may be reproduced in full only. The document may only be updated by MiCOM Labs personnel. All changes will be noted in the Document History section of the report.

**Title:** Mimosa Networks A5c, A5-14, A5-18  
**To:** FCC 15.407 & RSS 247 (DFS Bands), FCC Part 15B & ICES-003  
**Serial #:** MIMO09-U8\_Master Rev A  
**Issue Date:** 2<sup>nd</sup> August 2016  
**Page:** 13 of 25

---

**Mimosa Networks A5-18**



---

This test report may be reproduced in full only. The document may only be updated by MiCOM Labs personnel. All changes will be noted in the Document History section of the report.

**Mimosa Networks A5c**



---

This test report may be reproduced in full only. The document may only be updated by MiCOM Labs personnel. All changes will be noted in the Document History section of the report.



**Title:** Mimosa Networks A5c, A5-14, A5-18  
**To:** FCC 15.407 & RSS 247 (DFS Bands), FCC Part 15B & ICES-003  
**Serial #:** MIMO09-U8\_Master Rev A  
**Issue Date:** 2<sup>nd</sup> August 2016  
**Page:** 15 of 25

### 5.3. Equipment Model(s) and Serial Number(s)

Type	Description	Manufacturer	Model	Serial No.	Delivery Date
EUT	Access Point	Mimosa Networks	A5c	2115237991	17 <sup>th</sup> June 2016
EUT	Access Point	Mimosa Networks	A5-14	2112696984	17 <sup>th</sup> June 2016
EUT	Access Point	Mimosa Networks	A5-18	2119591877	17 <sup>th</sup> June 2016

### 5.4. Antenna Details

Type	Manufacturer	Model	Family	Gain (dBi)	BF Gain	Dir BW	X-Pol	Frequency Band (MHz)
external	KP Performance	KPPA-5GHZHV4P65-17 (X4)	Sector Antenna	17.3	-	360	Y	5250 – 5350 5470 – 5725
external	KP Performance	KPPA-5GHZHV4P65-17 (X4)	Sector Antenna	18.0	-	360	Y	5250 – 5350 5470 – 5725
integral	Mimosa	Not Provided	Circular Polarized Panel	5.0 <sup>1</sup>	-	360	Y	5250 – 5350 5470 – 5725
integral	Mimosa	Not Provided	Circular Polarized Panel	8.0	-	360	Y	5250 – 5350 5470 – 5725

<sup>1</sup> – Not tested results covered by 8.0 dBi antenna

BF Gain - Beamforming Gain  
Dir BW - Directional BeamWidth  
X-Pol - Cross Polarization

### 5.5. Cabling and I/O Ports

Port Type	Max Cable Length	# Of Ports	Screened	Conn Type	Data Type
Ethernet	100m	1	N	RJ-45	Data

This test report may be reproduced in full only. The document may only be updated by MiCOM Labs personnel. All changes will be noted in the Document History section of the report.



**Title:** Mimosa Networks A5c, A5-14, A5-18  
**To:** FCC 15.407 & RSS 247 (DFS Bands), FCC Part 15B & ICES-003  
**Serial #:** MIMO09-U8\_Master Rev A  
**Issue Date:** 2<sup>nd</sup> August 2016  
**Page:** 16 of 25

## 5.6. Test Configurations

Results for the following configurations are provided in this report:

Operational Mode(s) (802.11a/b/g/n/ac)	Data Rate with Highest Power MBit/s	Channel Frequency (MHz)		
		Low	Mid	High
<b>5250 - 5350 MHz</b>				
802.11ac-80	29.3	--	--	5,290.00
802.11ac-20	6.5	5,260.00	5,300.00	5,335.00
802.11ac-40	13.5	5,270.00	--	5,330.00
<b>5470 - 5725 MHz</b>				
802.11ac-80	29.3	5,530.00	5,610.00	5,690.00
802.11ac-20	6.5	5,485.00	5,580.00	5,720.00
802.11ac-40	13.5	5,510.00	5,550.00	5,710.00

## 5.7. Equipment Modifications

The following modifications were required to bring the equipment into compliance:

1. NONE

## 5.8. Deviations from the Test Standard

The following deviations from the test standard were required in order to complete the test program:

1. NONE

This test report may be reproduced in full only. The document may only be updated by MiCOM Labs personnel. All changes will be noted in the Document History section of the report.





**Title:** Mimosa Networks A5c, A5-14, A5-18  
**To:** FCC 15.407 & RSS 247 (DFS Bands), FCC Part 15B & ICES-003  
**Serial #:** MIMO09-U8\_Master Rev A  
**Issue Date:** 2<sup>nd</sup> August 2016  
**Page:** 17 of 25

## 6. TEST SUMMARY

### List of Measurements

Test Header	Result	Comments
<b>Conducted Testing</b>	See Report MIMO09-U8_Conducted	
(a) Peak Transmit Power	Complies	
(a) 26 dB & 99% Bandwidth	Complies	
(a)(5) Power Spectral Density	Complies	
<b>Radiated Testing</b>	See Report MIMO09-U8_Radiated	
(b)(2) Radiated Spurious & Band-Edge Emissions	Complies	
KP Performance KPPA-5GHZHV4P65-17 X4	Complies	
Mimosa Networks A5-14	Complies	
Mimosa Networks A5-18	Complies	
<b>DFS Testing</b>	See Report MIMO09-U8_DFS	
(h)(2) Dynamic Frequency Selection (DFS)	Complies	
(ii) Channel Availability Check	Complies	
(a) Initial CAC	Complies	
(b) Beginning CAC	Complies	
(c) End CAC	Complies	
(iii) Channel Close / Transmission Time	Complies	
(iv) Non-Occupancy Period	Complies	
Probability of Detection	Complies	
Detection Bandwidth	Complies	

This test report may be reproduced in full only. The document may only be updated by MiCOM Labs personnel. All changes will be noted in the Document History section of the report.

## **7. TEST EQUIPMENT CONFIGURATION(S)**

### **7.1. Conducted**

Conducted RF Emission Test Set-up(s)

The following tests were performed using the conducted test set-up shown in the diagram below;

1. Peak Transmit Power
2. 26 dB & 99% Bandwidth
3. Power Spectral Density

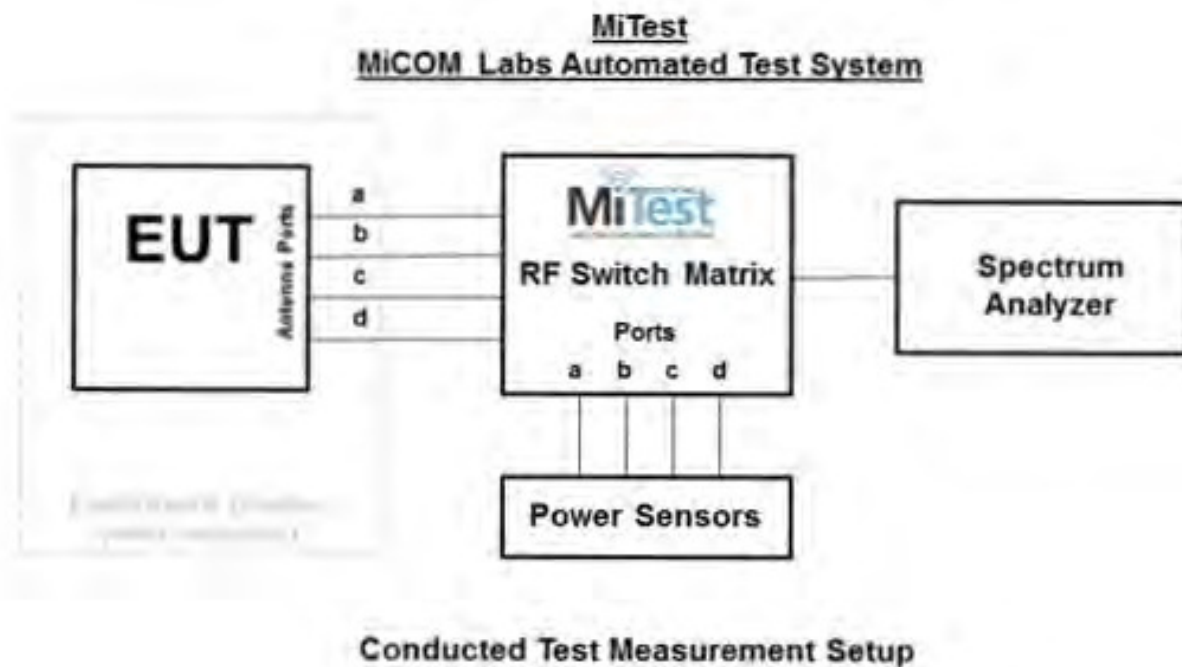

A full system calibration was performed on the test station and any resulting system losses (or gains) were taken into account in the production of all final measurement data.



**Title:** Mimosa Networks A5c, A5-14, A5-18  
**To:** FCC 15.407 & RSS 247 (DFS Bands), FCC Part 15B & ICES-003  
**Serial #:** MIMO09-U8\_Master Rev A  
**Issue Date:** 2<sup>nd</sup> August 2016  
**Page:** 19 of 25

Asset#	Description	Manufacturer	Model#	Serial#	Calibration Due Date
158	Barometer/Thermometer	Control Company	4196	E2846	01 Dec 2016
287	Rohde & Schwarz 40 GHz Receiver	Rhode & Schwarz	ESIB40	100201	27 Aug 2016
376	USB 10MHz - 18GHz Average Power Sensor	Agilent	U2000A	MY51440005	23 Oct 2016
381	4x4 RF Switch Box	MiCOM Labs	MiTest RF Switch Box	MIC002	18 Jun 2016
419	Laptop with Labview Software	Lenova	W520	TS02	Not Required
420	USB to GPIB Interface	National Instruments	GPIB-USB HS	1346738	Not Required
435	USB Wideband Power Sensor	Boonton	55006	8730	31 Jul 2016
440	USB Wideband Power Sensor	Boonton	55006	9178	25 Sep 2016
441	USB Wideband Power Sensor	Boonton	55006	9179	25 Sep 2016
442	USB Wideband Power Sensor	Boonton	55006	9181	25 Sep 2016
460	Dell Computer	Dell	Optiplex330	BC944G1	Not Required
RF#2 GPIB#1	GPIB cable to Power Supply	HP	GPIB	None	Not Required
RF#2 SMA#1	EUT to Mitest box port 1	Flexco	SMA Cable port1	None	18 Jun 2016
RF#2 SMA#2	EUT to Mitest box port 2	Flexco	SMA Cable port2	None	18 Jun 2016
RF#2 SMA#3	EUT to Mitest box port 3	Flexco	SMA Cable port3	None	18 Jun 2016
RF#2 SMA#4	EUT to Mitest box port 4	Flexco	SMA Cable port4	None	18 Jun 2016
RF#2 SMA#SA	Mitest box to SA	Flexco	SMA Cable SA	None	18 Jun 2016
RF#2 USB#1	USB Cable to Mitest Box	Dynex	USB Cable	None	Not Required

This test report may be reproduced in full only. The document may only be updated by MiCOM Labs personnel. All changes will be noted in the Document History section of the report.

## 7.2. Radiated Spurious Emission Test Set-up > 1 GHz

The following tests were performed using the radiated test set-up shown in the diagram below.

Radiated Spurious and Band-edge Emissions

### Radiated Emission Measurement Setup

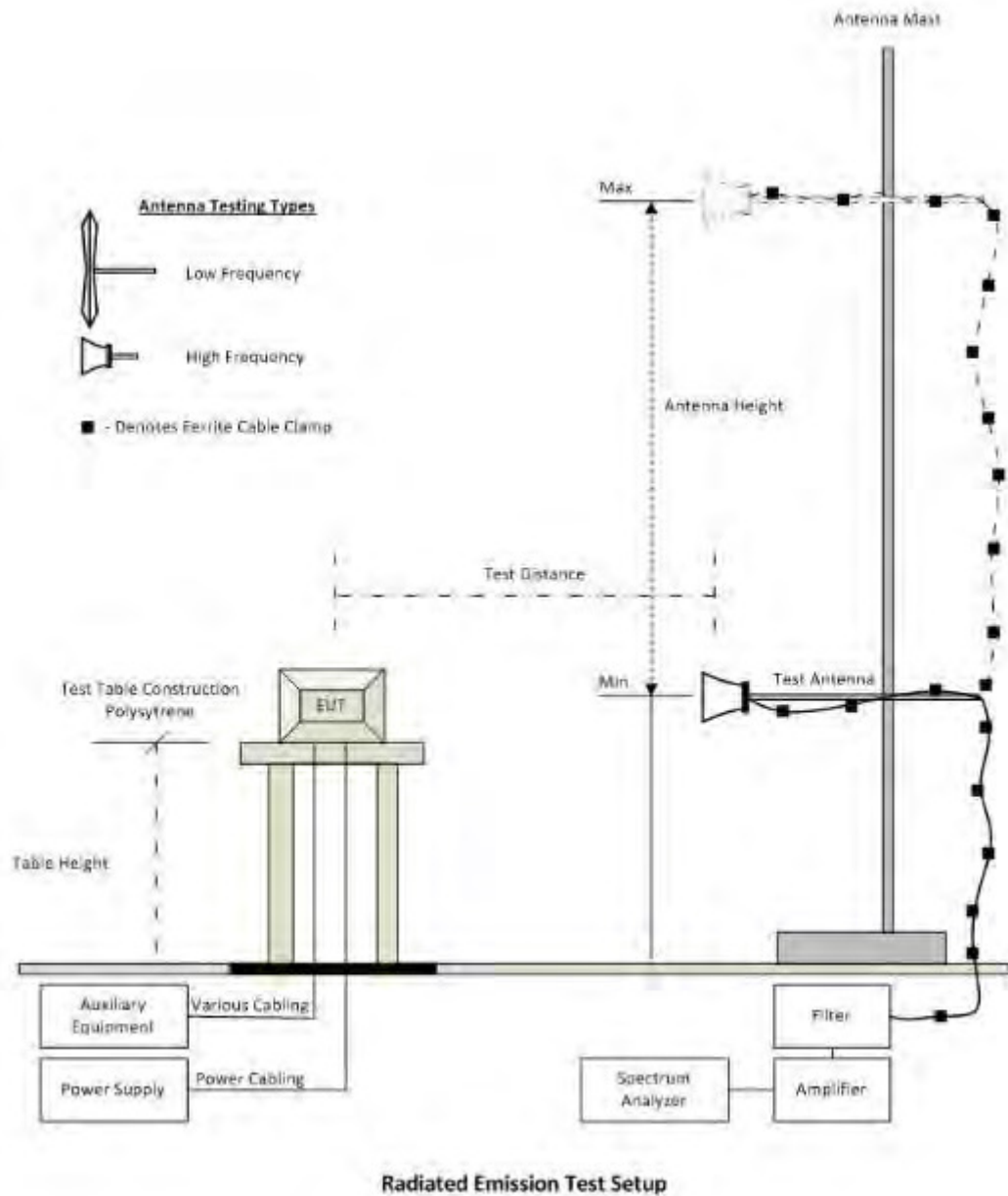

This test report may be reproduced in full only. The document may only be updated by MiCOM Labs personnel. All changes will be noted in the Document History section of the report.



**Title:** Mimosa Networks A5c, A5-14, A5-18  
**To:** FCC 15.407 & RSS 247 (DFS Bands), FCC Part 15B & ICES-003  
**Serial #:** MIMO09-U8\_Master Rev A  
**Issue Date:** 2<sup>nd</sup> August 2016  
**Page:** 21 of 25

Asset#	Description	Manufacturer	Model#	Serial#	Calibration Due Date
158	Barometer/Thermometer	Control Company	4196	E2846	01 Dec 2016
170	Video System Controller for Semi Anechoic Chamber	Panasonic	WV-CY101	04R08507	Not Required
287	Rohde & Schwarz 40 GHz Receiver	Rhode & Schwarz	ESIB40	100201	27 Aug 2016
338	Sunol 30 to 3000 MHz Antenna	Sunol	JB3	A052907	15 Aug 2016
396	2.4 GHz Notch Filter	Microtronics	BRM50701	001	18 Aug 2016
397	Amp 10 - 2500MHz	MiCOM Labs	Amp 10 - 2500 MHz	NA	24 Feb 2016
399	ETS 1-18 GHz Horn Antenna	ETS	3117	00154575	18 <sup>th</sup> Oct 2016
406	Amplifier for Radiated Emissions	MiCOM Labs	40dB 1 to 18GHz Amp	0406	28 May 2016
410	Desktop Computer	Dell	Inspiron 620	WS38	Not Required
411	Mast/Turntable Controller	Sunol Sciences	SC98V	060199-1D	Not Required
412	USB to GPIB Interface	National Instruments	GPIB-USB HS	11B8DC2	Not Required
413	Mast Controller	Sunol Science	TWR95-4	030801-3	Not Required
415	Turntable Controller	Sunol Sciences	Turntable Controller	None	Not Required
447	Rad Emissions Test Software	MiCOM	Rad Emissions Test Software Version 1.0.73	447	Not Required
462	Schwarzbeck cable from Antenna to Amplifier.	Schwarzbeck	AK 9513	462	25 Feb 2016
463	Schwarzbeck cable from Amplifier to Bulkhead.	Schwarzbeck	AK 9513	463	25 Feb 2016
464	Schwarzbeck cable from Bulkhead to Receiver	Schwarzbeck	AK 9513	464	25 Feb 2016
465	Low Pass Filter DC-1000 MHz	Mini-Circuits	NLP-1200+	VUU01901402	18 Aug 2016
480	Cable - Bulkhead to Amp	SRC Haverhill	157-157-3050360	480	11 Aug 2016
481	Cable - Bulkhead to Receiver	SRC Haverhill	151-151-3050787	481	11 Aug 2016
482	Cable - Amp to Antenna	SRC Haverhill	157-157-3051574	482	11 Aug 2016

This test report may be reproduced in full only. The document may only be updated by MiCOM Labs personnel. All changes will be noted in the Document History section of the report.

### 7.3. DFS - Conducted

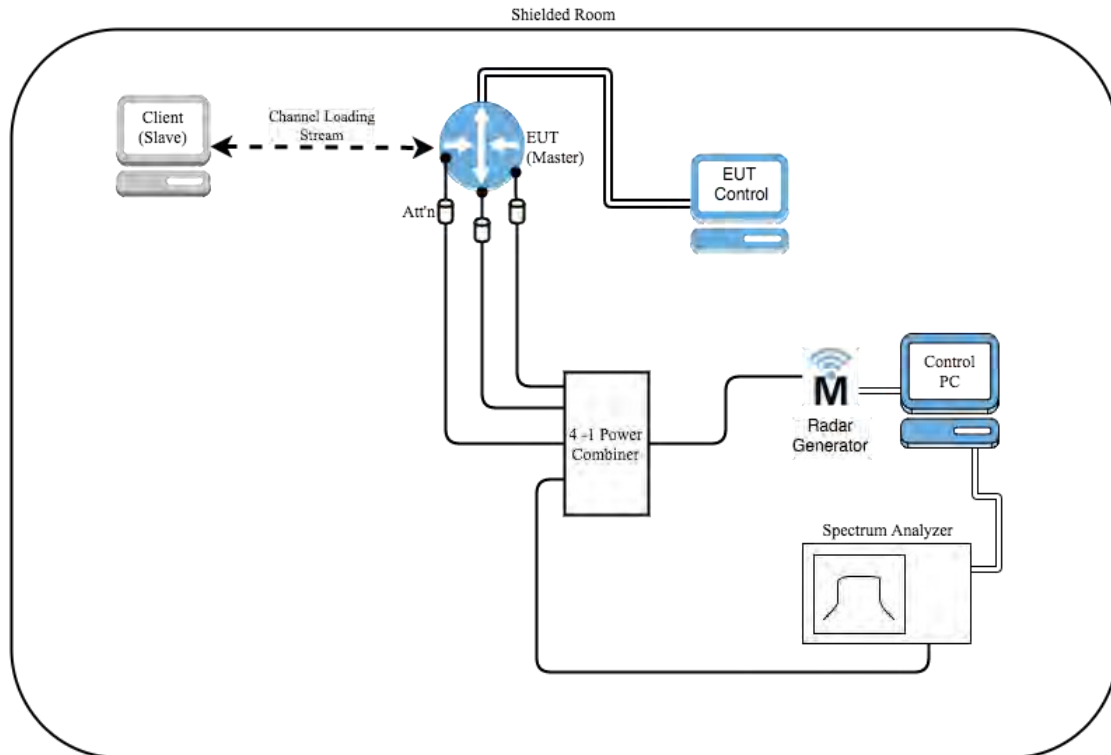

A full system calibration was performed on the test station and any resulting system losses (or gains) were taken into account in the production of all final measurement data.



**Title:** Mimosa Networks A5c, A5-14, A5-18  
**To:** FCC 15.407 & RSS 247 (DFS Bands), FCC Part 15B & ICES-003  
**Serial #:** MIMO09-U8\_Master Rev A  
**Issue Date:** 2<sup>nd</sup> August 2016  
**Page:** 23 of 25

---

Asset#	Description	Manufacturer	Model#	Serial#	Calibration Due Date
158	Barometer/Thermometer	Control Company	4196	E2846	01 Dec 2016
299	Test Software DFS Test System	Aeroflex	DFS test Software	V2.7.0	Not Required
359	DFS System	Aeroflex	PXI-1042	300001/004	13 Dec 2016
417	Laptop for DFS with DFS software	Lenovo	W520	DFS	Not Required
418	PCI-e interface card	National Instruments	Express 8360	174AAC5	Not Required
422	Splitter/Combiner	Pasternack	PE 2031	001	Cal when used
495	RF Power Divider	Micon Precise Corp	91002	495	Cal when used
71	Spectrum Analyzer 9KHz-50GHz	HP	8565E	3425A00181	06 Aug 2016
DFS PCIe#1	PCIe cable for Aeroflex	National Instruments	PCIe cable	None	Not Required
DFS SMA#1	SMA Cable for DFS	Megaphase	SMA Cable	None	Cal when used
DFS SMA#2	SMA Cable for DFS	Megaphase	SMA Cable	None	Cal when used
DFS SMA#3	SMA Cable for DFS	Megaphase	SMA Cable	None	Cal when used
DFS SMA#4	SMA Cable for DFS	Megaphase	SMA Cable	None	Cal when used

---

This test report may be reproduced in full only. The document may only be updated by MiCOM Labs personnel. All changes will be noted in the Document History section of the report.



**Title:** Mimosa Networks A5c, A5-14, A5-18  
**To:** FCC 15.407 & RSS 247 (DFS Bands), FCC Part 15B & ICES-003  
**Serial #:** MIMO09-U8\_Master Rev A  
**Issue Date:** 2<sup>nd</sup> August 2016  
**Page:** 24 of 25

## 8. MEASUREMENT AND PRESENTATION OF TEST DATA

The measurement and graphical data presented in this test report was generated automatically using state-of-the-art technology creating an easy to read report structure. Numerical measurement data is separated from supporting graphical data (plots) through hyperlinks. Numerical measurement data can be reviewed without scrolling through numerous graphical pages to arrive at the next data matrix.

Plots have been relegated into the Appendix 'Graphical Data'.

Test and report automation was performed by [MiTest](#). [MiTest](#) is an automated test system developed by MiCOM Labs. [MiTest](#) is the first cloud based modular test system enabling end-to-end automation of regulatory compliance testing for conducted RF testing.



The MiCOM Labs "[MiTest](#)" Automated Test System" (Patent Pending)

This test report may be reproduced in full only. The document may only be updated by MiCOM Labs personnel. All changes will be noted in the Document History section of the report.





575 Boulder Court  
Pleasanton, California 94566, USA  
Tel: +1 (925) 462 0304  
Fax: +1 (925) 462 0306  
[www.micomlabs.com](http://www.micomlabs.com)