

FCC Test Report

Product Name : Mimosa C5c
Trade Name : *mimosa*
Model No. : C5c
FCC ID. : 2ABZJ-100-00018

Applicant : Mimosa Networks
Address : 469 El Camino Real, Suite 100 Santa Clara,
CA 95050, USA

Date of Receipt : Jan. 03, 2017
Issued Date : Apr. 17, 2017
Report No. : 1710110R-RFUSP22V00
Report Version : V1.0



The declaration results relate only to the samples calculated.
The declaration shall not be reproduced except in full without the written approval of DEKRA Testing and Certification Co., Ltd.

Test Report Certification

Issued Date : Apr. 17, 2017

Report No. : 1710110R-RFUSP22V00



Product Name : Mimoso C5c
Applicant : Mimoso Networks
Address : 469 El Camino Real, Suite 100 Santa Clara, CA 95050, USA
Manufacturer : Lite-On Network Communication (Dongguan) Limited
Model No. : C5c
FCC ID. : 2ABZJ-100-00018
EUT Voltage : AC 100-240V, 50-60Hz
Testing Voltage : AC 120V/ 60Hz
Trade Name : *mimosa*
Applicable Standard : FCC 90 Subpart Y
Test Lab : Hsin Chu Laboratory
Test Result : Complied

The test results relate only to the samples tested.

The test report shall not be reproduced except in full without the written approval of DEKRA Testing and Certification Co., Ltd.

Documented By : 

(Demi Chang / Senior Engineering Adm. Specialist)

Tested By : 

(Scott Chang / Assistant Engineer)

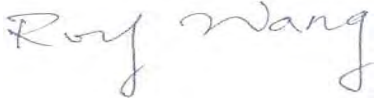
Approved By : 

(Roy Wang / Director)

Revision History

Report No.	Version	Description	Issued Date
1710110R-RFUSP22V00	V1.0	Initial issue of report.	Apr. 17, 2017

Laboratory Information

We, **DEKRA Testing and Certification Co., Ltd.**, are an independent RF consultancy that was established the whole facility in our laboratories. The test facility has been accredited/accepted (audited or listed) by the following related bodies in compliance with ISO 17025 specified testing scopes:

Taiwan R.O.C.	:	TAF, Accreditation Number: 3024
USA	:	FCC, Registration Number: 834100
Canada	:	IC, Submission No: 181665 IC Registration Number: 22397-1 / 22397-2 / 22397-3

The related certificate for our laboratories about the test site and management system can be downloaded from DEKRA Testing and Certification Co., Ltd. Web Site:

<http://www.dekra.com.tw/english/about/certificates.aspx?bval=5>

The address and introduction of DEKRA Testing and Certification Co., Ltd. laboratories can be founded in our Web site : http://www.dekra.com.tw/index_en.aspx

If you have any comments, Please don't hesitate to contact us. Our contact information is as below:

Hsin Chu Laboratory:

No.75-2, 3rd Lin, WangYe Keng, Yonghxing Tsuen, Qionglin Shiang, Hsinchu County 307, Taiwan (R.O.C.)

TEL:+886-3-592-8858 / FAX:+886-3-592-8859

No.372, Sec. 4, Zhongxing Rd., Zhudong Township, Hsinchu County 310, Taiwan

No.372-2, Sec. 4, Zhongxing Rd., Zhudong Township, Hsinchu County 310, Taiwan

TEL:+886-3-582-8001 / FAX:+886-3-5828-958 E-Mail : info.tw@dekra.com

Lin Kou Laboratory:

No. 5-22, Ruishukeng, Linkou Dist., New Taipei City 24451, Taiwan (R.O.C.)

TEL : +886-2-8601-3788 / FAX : +886-2-8601-3789

E-Mail : info.tw@dekra.com

TABLE OF CONTENTS

Description	Page
1. General Information.....	7
1.1. EUT Description	7
1.2. Test Mode	9
1.3. Tested System Details	10
1.4. Configuration of tested System	10
1.5. EUT Exercise Software	10
2. Transmitter output power.....	11
2.1. Test Equipment.....	11
2.2. Test Setup	11
2.3. Limits	11
2.4. Test Procedure	12
2.5. Uncertainty	12
2.6. Test Result.....	13
3. Peak Power Spectral Density	25
3.1. Test Equipment.....	25
3.2. Test Setup	25
3.3. Limits	25
3.4. Test Procedure	26
3.5. Uncertainty	26
3.6. Test Result.....	27
4. Occupied Bandwidth.....	39
4.1. Test Equipment.....	39
4.2. Test Setup	39
4.3. Limits	39
4.4. Uncertainty	39
4.5. Test Result.....	40
5. Power Spectral Density Mask.....	52
5.1. Test Equipment.....	52
5.2. Test Setup	52
5.3. Limits	52
5.4. Test Procedure	54
5.5. Uncertainty	54
5.6. Test Result.....	55
6. Peak Excursion	67
6.1. Test Equipment.....	67
6.2. Test Setup	67
6.3. Limits	67
6.4. Test Procedure	68
6.5. Uncertainty	68
6.6. Test Result.....	69
7. Frequency Stability	81
7.1. Test Equipment.....	81
7.2. Test Setup	81

7.3.	Limits	81
7.4.	Test Procedure	82
7.5.	Uncertainty	82
7.6.	Test Result.....	83
8.	Conductive Spurious Emission.....	89
8.1.	Test Equipment.....	89
8.2.	Test Setup	89
8.3.	Limits	89
8.4.	Test Procedure	89
8.5.	Uncertainty	89
8.6.	Test Result.....	90
9.	Radiated Emission	102
9.1.	Test Equipment.....	102
9.2.	Test Setup	102
9.3.	Limits	103
9.4.	Test Procedure	103
9.5.	Uncertainty	103
9.6.	Test Result.....	104
Attachment 1		120
	Test Setup Photograph.....	120
Attachment 2.....		124
	EUT External Photograph.....	124
Attachment 2.....		129
	EUT Internal Photograph.....	129

1. General Information

1.1. EUT Description

Product Name	Mimosa C5c
Trade Name	<i>mimosa</i>
Model No.	C5c
Frequency Range	4940-4990MHz
Type of Modulation	Orthogonal Frequency Division Multiplexing (OFDM)

Antenna Information	
Antenna Type	Dish Antenna & Dipole Antenna
Antenna Gain	Dish : 26dBi Dipole : 2.5dBi

Accessories Information	
Dish Antenna	Ubiquiti Networks Inc. / RocketDish
Dipole Antenna	WHA YU INDUSTRIAL CO., LTD. / N100-510037-A

Channel Frequency Channel Frequency Channel Frequency
 Channel 190: 4950MHz Channel 193: 4965MHz Channel 196: 4980MHz

Note:

1. These tests are conducted on a sample for the purpose of demonstrating compliance with Part 90 Subpart Y.
2. This device is a composite device in accordance with Part 15 regulations. The function receiving was measured and made a test report that the report number is 1710110R-RFUSP01V00 under Declaration of Conformity.
3. Power setting Index table as below, this index table only for this device.

Dipole			
Frequency (MHz)	Modulation	Channel	Index
4950	VHT20	190	18
4965		193	18
4980		196	18
Dish			
Frequency (MHz)	Modulation	Channel	Index
4950	VHT20	190	0
4965		193	0
4980		196	0

1.2. Test Mode

DEKRA verified the construction and function in typical operation. All the test modes are performed in normal operation and are defined as:

TX	Mode 1: Transmit-Dish Mode 2: Transmit-Dipole
----	--

Performed Item	section	Mode 1	Mode 2
Transmitter output power	Part 90.12151(a)	Yes	Yes
Peak Power Spectral Density	Part 90.12151(a)	Yes	Yes
Occupied Bandwidth	Part 90.210 & 2.1049	Yes	Yes
Power spectral density mask	Part 90.1213	Yes	Yes
Peak Excursion	Part 90.12151(e)	Yes	Yes
Frequency Stability	Part 90.1213	Yes	Yes
Conductive Spurious emission	Part 90.210	Yes	Yes
Radiated Spurious Emission	Part 90.210	Yes	Yes

1.3. Tested System Details

The types for all equipments, plus descriptions of all cables used in the tested system (including inserted cards) are:

Product	Manufacturer	Model No.	Serial No.	FCC ID	Power Cord	
1	POE	PHIHONG	POE16R-560Q	N/A	DoC	--
2	Notebook PC	ACER	MS2296	LUSCV021391 150332C2000	DoC	Non-Shielded, 2.5m one ferrite core bonded

1.4. Configuration of tested System

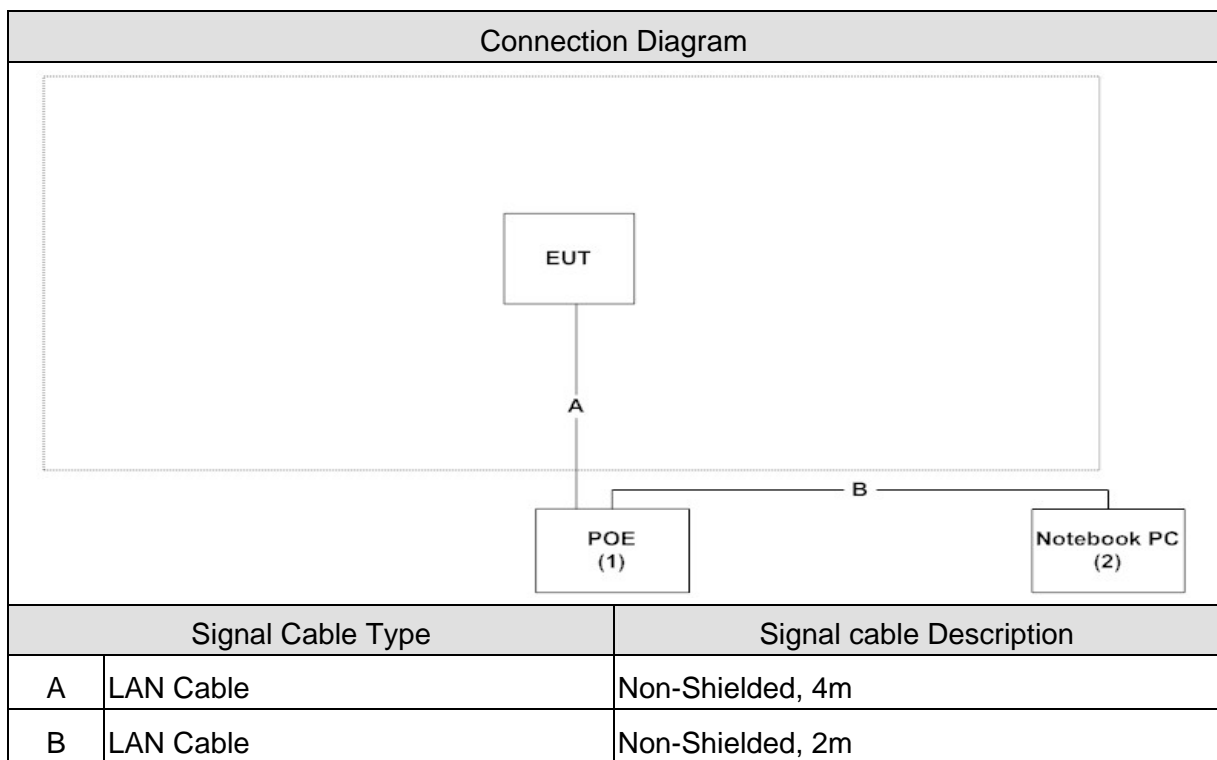

1.5. EUT Exercise Software

1	Setup the EUT as shown in Section 1.4.
2	The EUT power by the POE and execute the Telnet by the Notebook.
3	Configure the test mode, the test channel, and the data rate.
4	Start the continuous
5	Verify that the EUT works properly.

2. Transmitter output power

2.1. Test Equipment

The following test equipment's are used during the radiated emission tests:

Transmitter output power / SR10-H

Instrument	Manufacturer	Model No.	Serial No	Next Cal. Date
Spectrum Analyzer	Agilent	N9010A	US47140172	2017/08/08

Note: All equipment's that need to calibrate are with calibration period of 1 year.

2.2. Test Setup

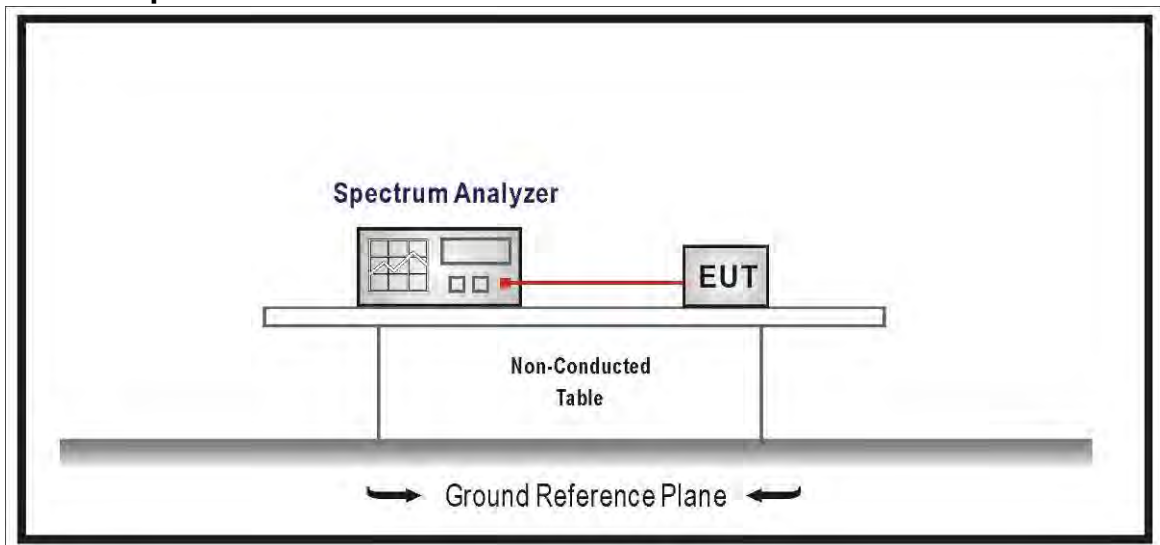

2.3. Limits

§90.1215: The transmitting power of stations operating in the 4940-4990 MHz band must not exceed the maximum limits in this section.

Channel bandwidth (MHz)	Low power maximum conducted output power (dBm)	High power maximum conducted output power (dBm)
1	7	20
5	14	27
10	17	30
15	18.8	31.8
20	20	33

2.4. Test Procedur

TIA-603-C Section 2.2.1

The EUT transmitter output was connected through an appropriate 50-ohm attenuator to a spectrum analyzer. The peak transmit power was measured as a conducted emission over the interval of continuous transmission in terms of an RMS equivalent voltage with a 1 second sweep and a resolution bandwidth of 1 MHz.

A 10 dB attenuator was used between the EUT and the spectrum analyzer for all power measurements. No cable was used between the EUT and the analyzer.

The system loss was measured to be 10 dB and entered as an offset into the spectrum analyzer.

2.5. Uncertainty

± 1.62 dB

2.6. Test Result

Product	Mimosa C5c		
Test Item	Transmitter output power		
Test Mode	Mode 1: Transmit-Dish		
Date of Test	2017/04/13	Test Site	SR10-H

Peak Transmit Power - 20MHz Bandwidth

Channel	Channel Power			Limit (dBm)
	ANT0 (dBm)	ANT1 (dBm)	ANT0+1 (dBm)	
190	-1.350	-0.910	1.886	<3
193	-1.390	-0.910	1.867	
196	-1.370	-0.760	1.956	

Antenna gain = 26 dBi

Reduced Power Limit = Original Power Limit – (Antenna Gain – 9 dBi) = 3 dBm

Channel 190_ANT0

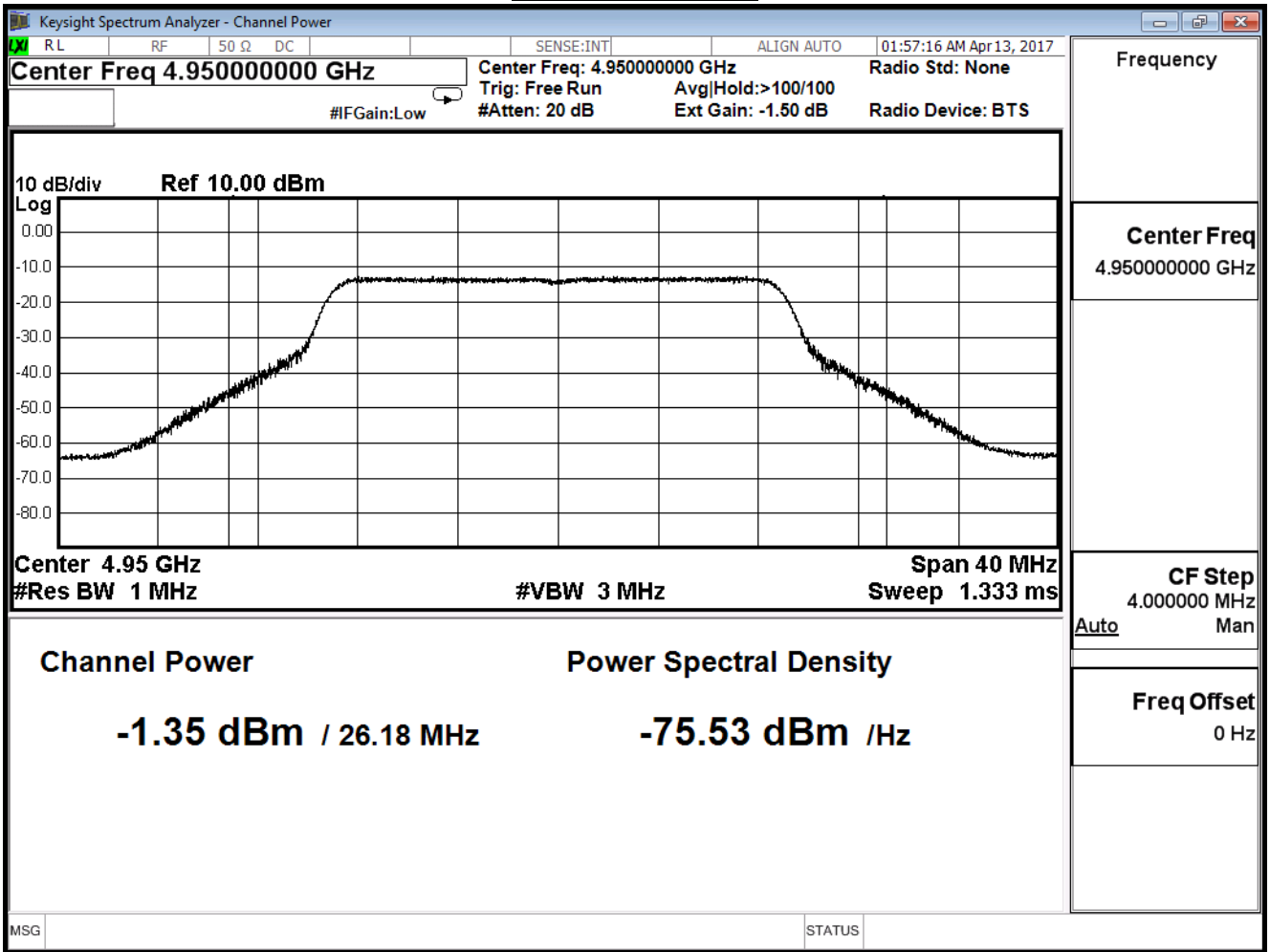

Channel 193 ANT0

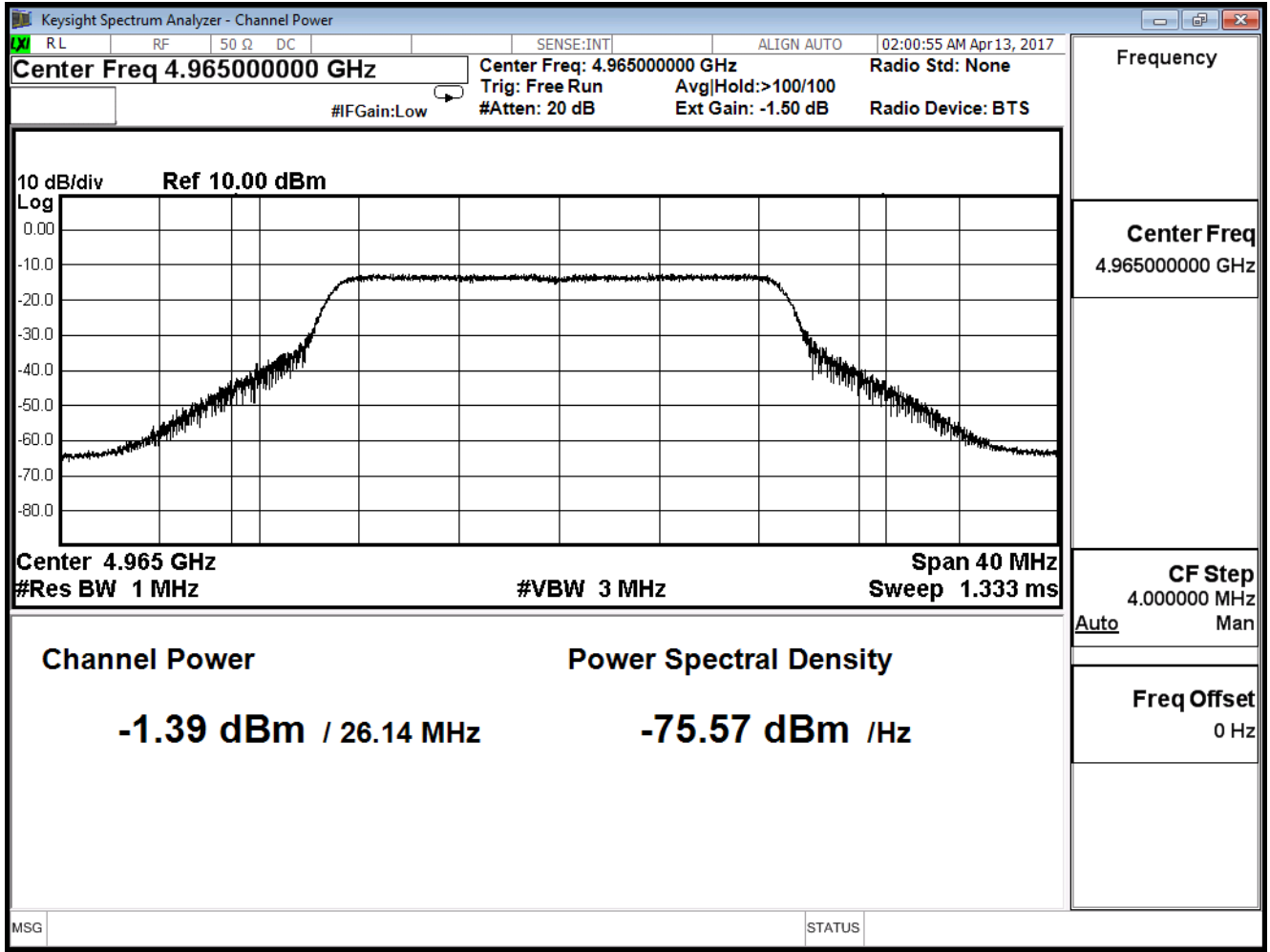

Channel 196 ANT0

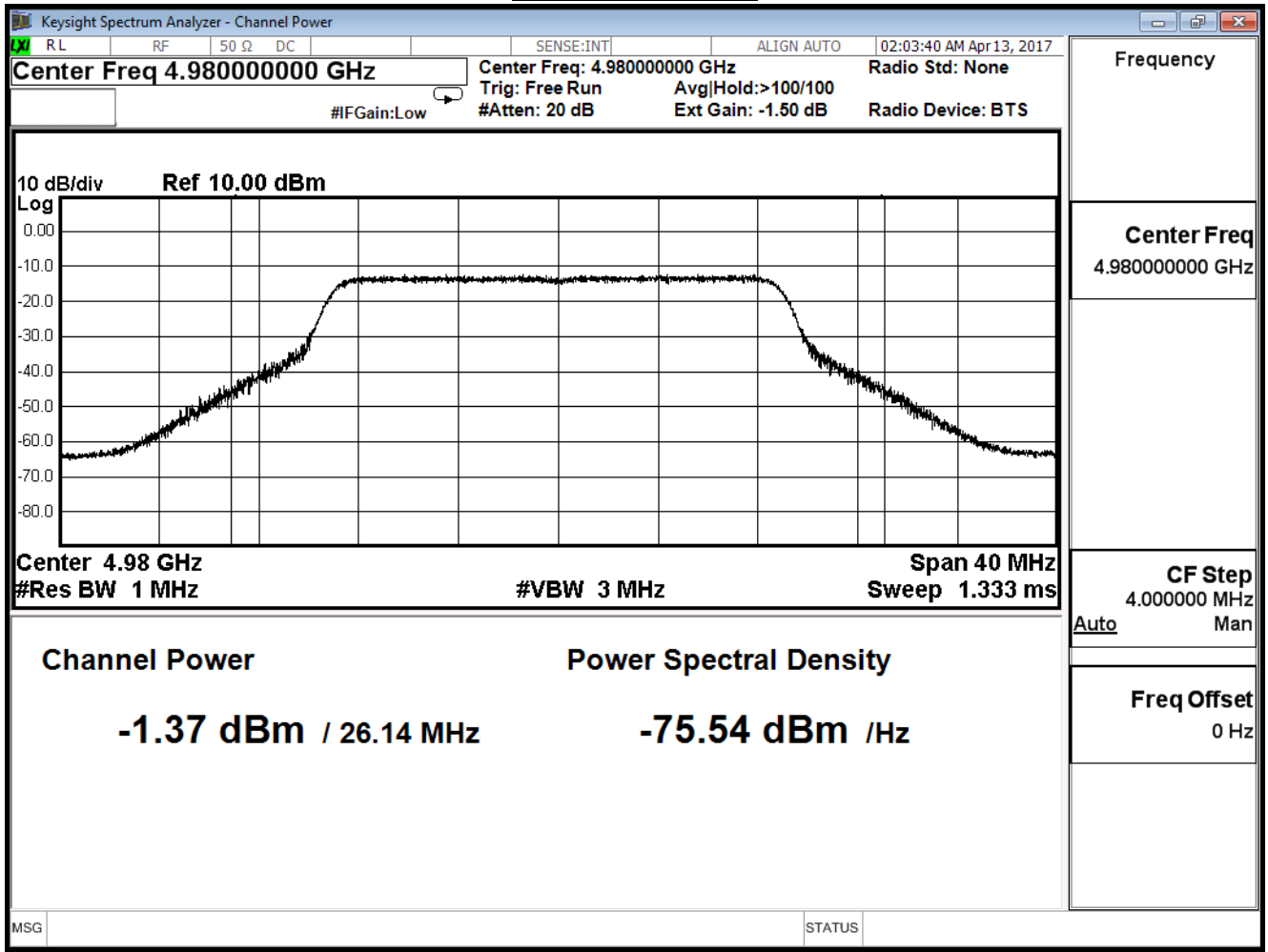

Channel 190 ANT1

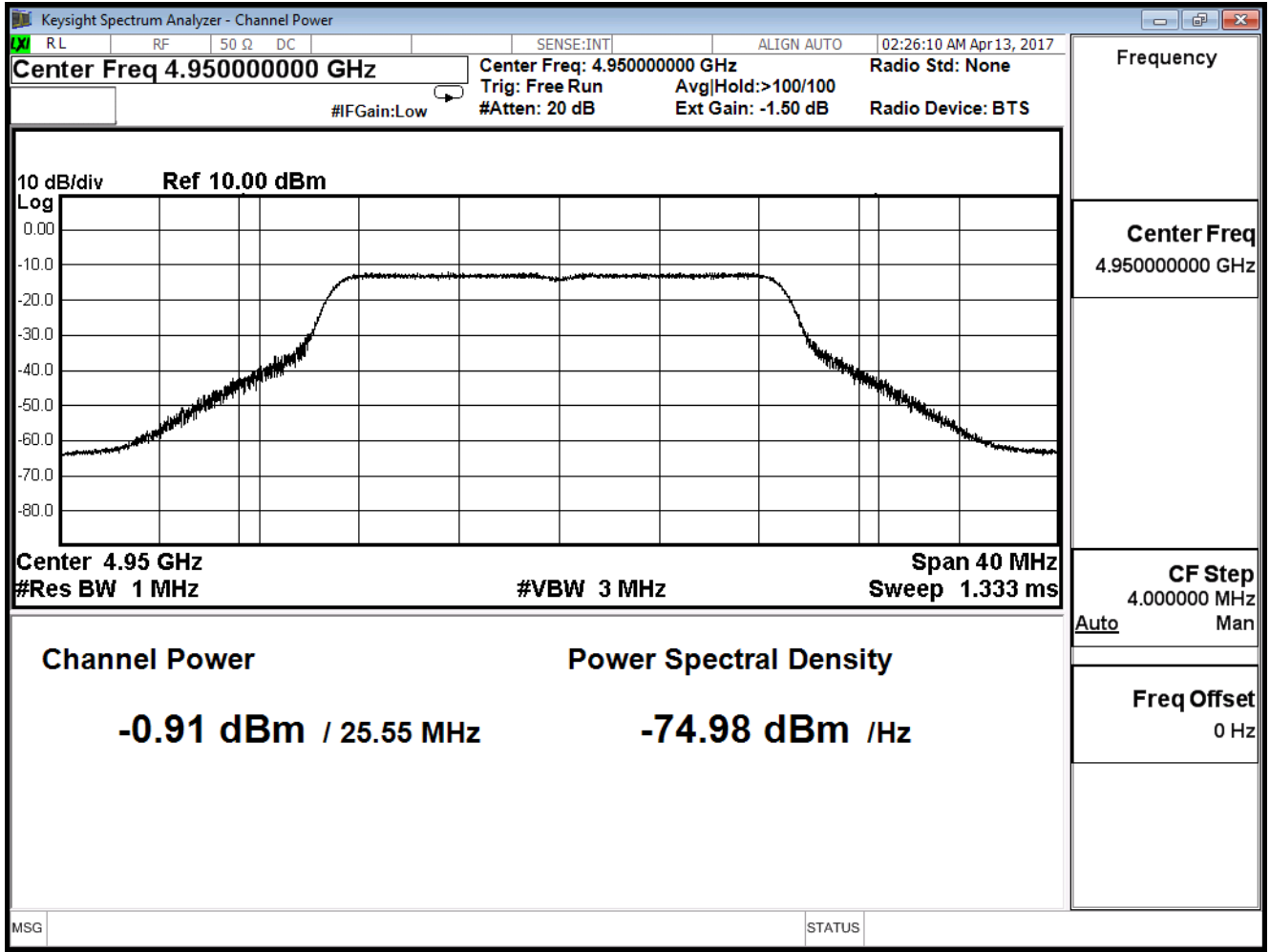

Channel 193 ANT1

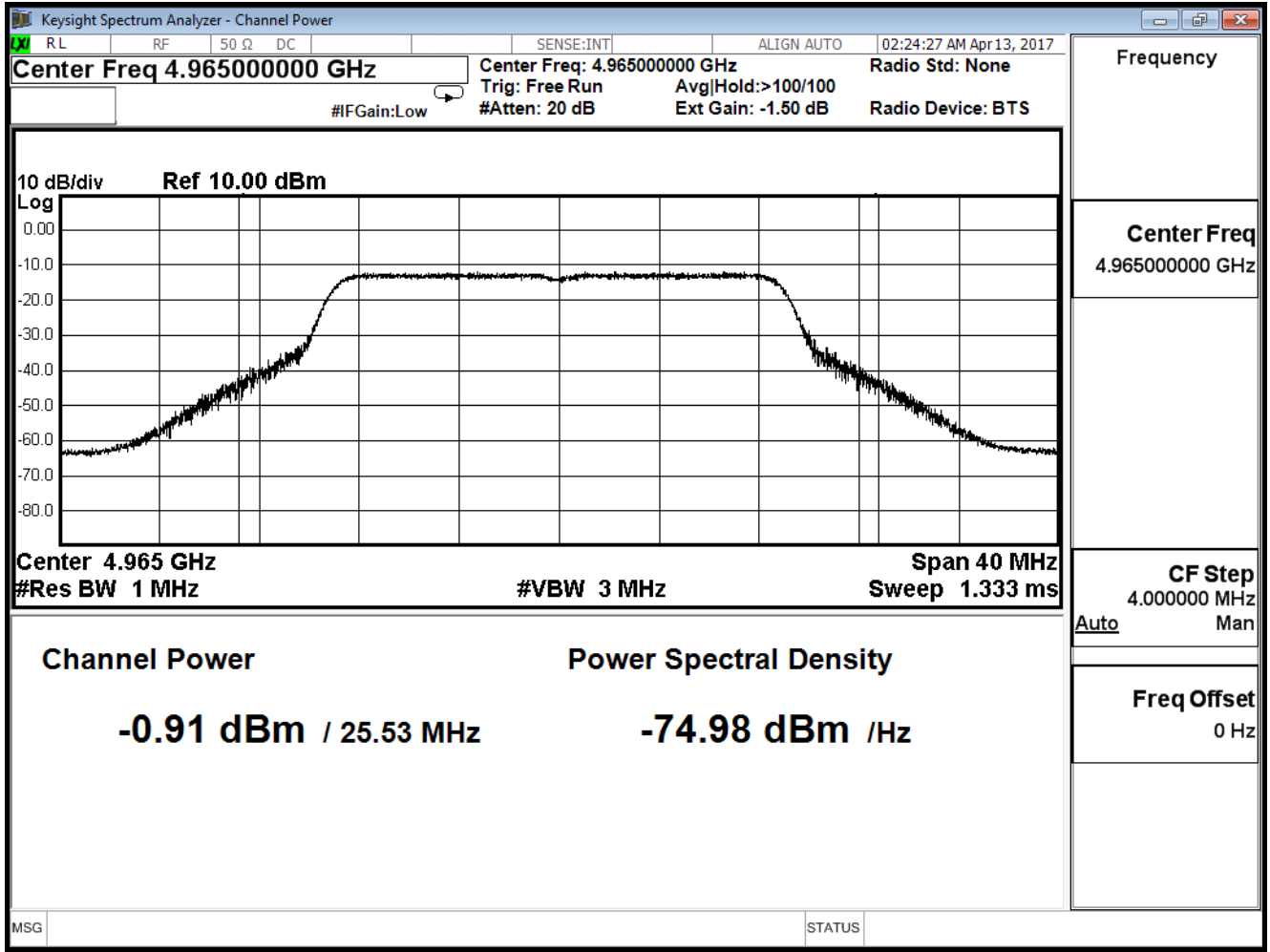

Channel 196 ANT1

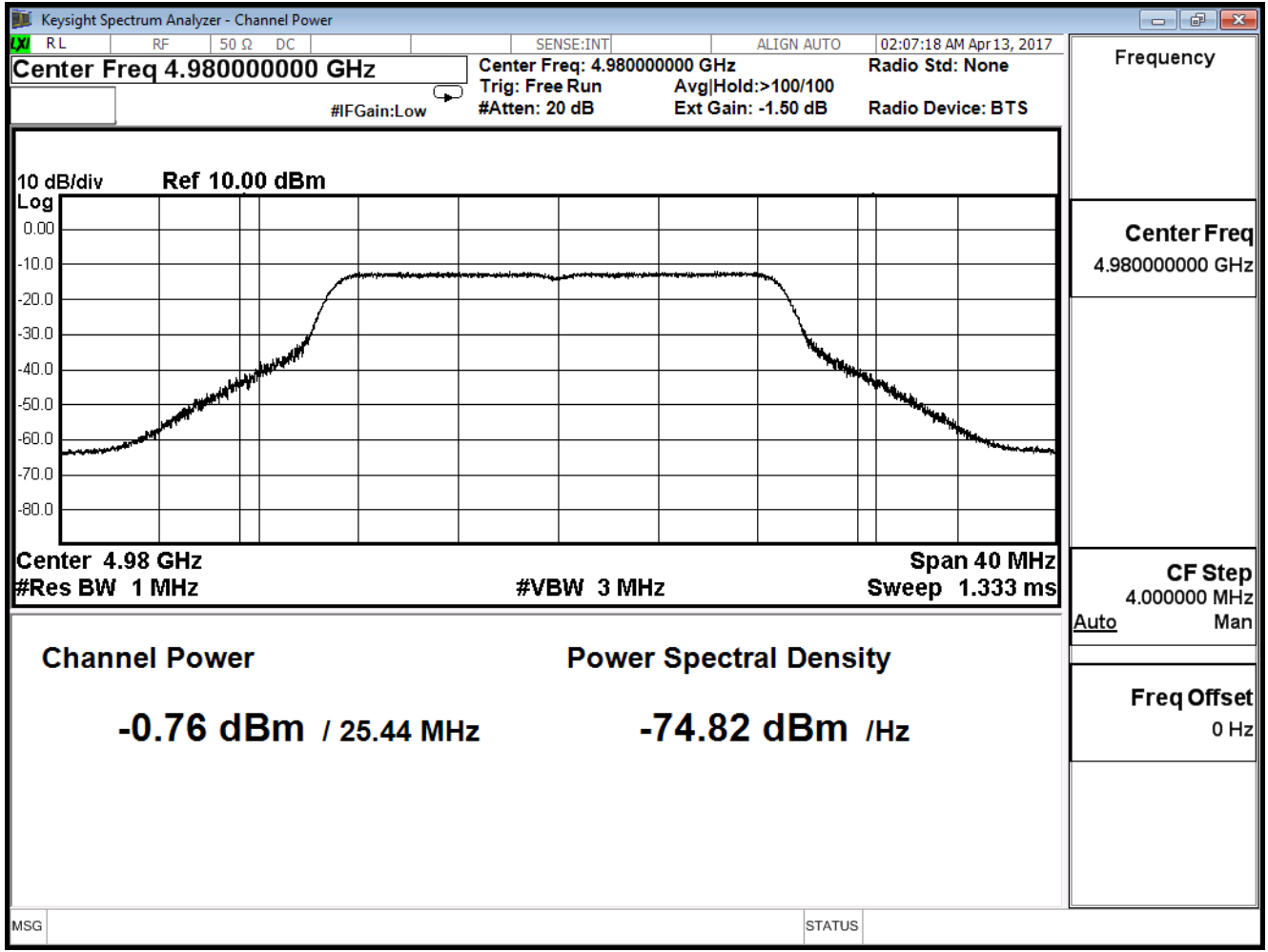

Product	Mimosa C5c		
Test Item	Transmitter output power		
Test Mode	Mode 2: Transmit-Dipole		
Date of Test	2017/04/08	Test Site	SR10-H

Peak Transmit Power - 20MHz Bandwidth

Channel	Channel Power			Limit (dBm)
	ANT0 (dBm)	ANT1 (dBm)	ANT0+1 (dBm)	
190	15.490	15.610	18.561	<20
193	15.350	15.430	18.400	
196	15.240	15.350	18.306	

Channel 190 ANT0

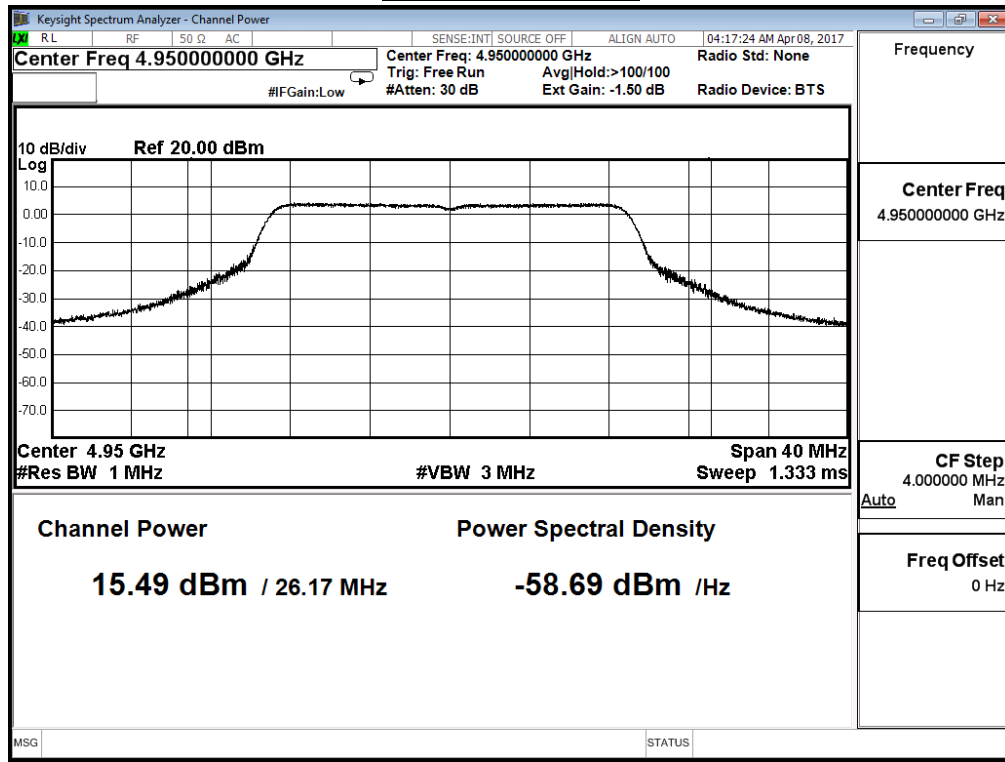

Channel 193 ANT0

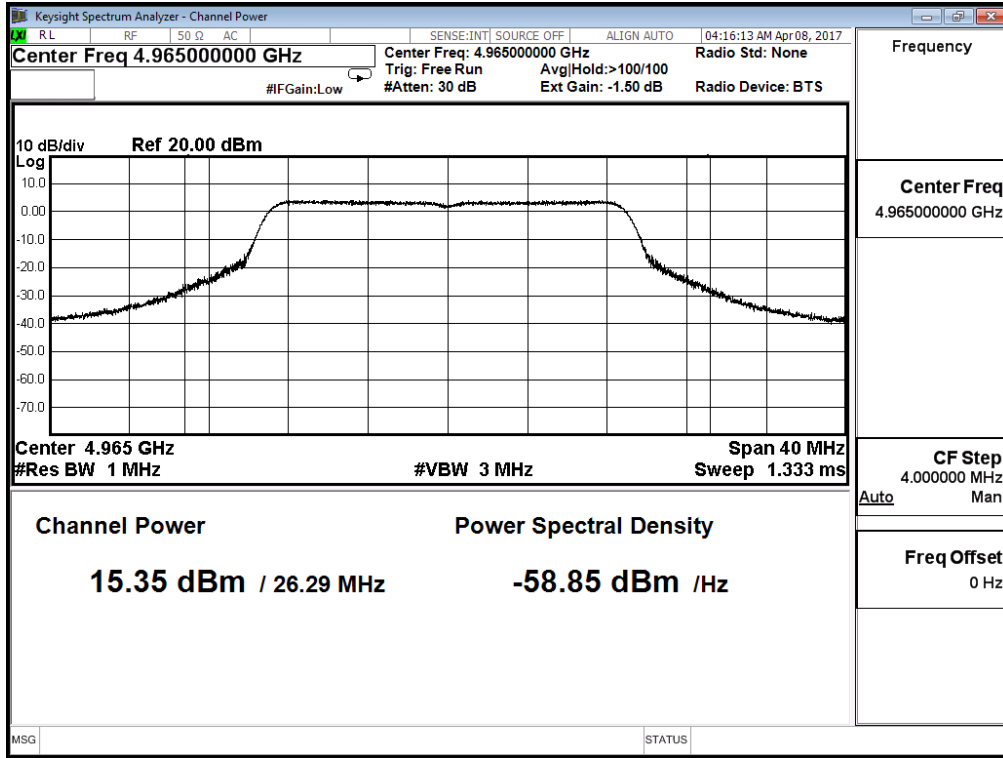

Channel 196 ANT0

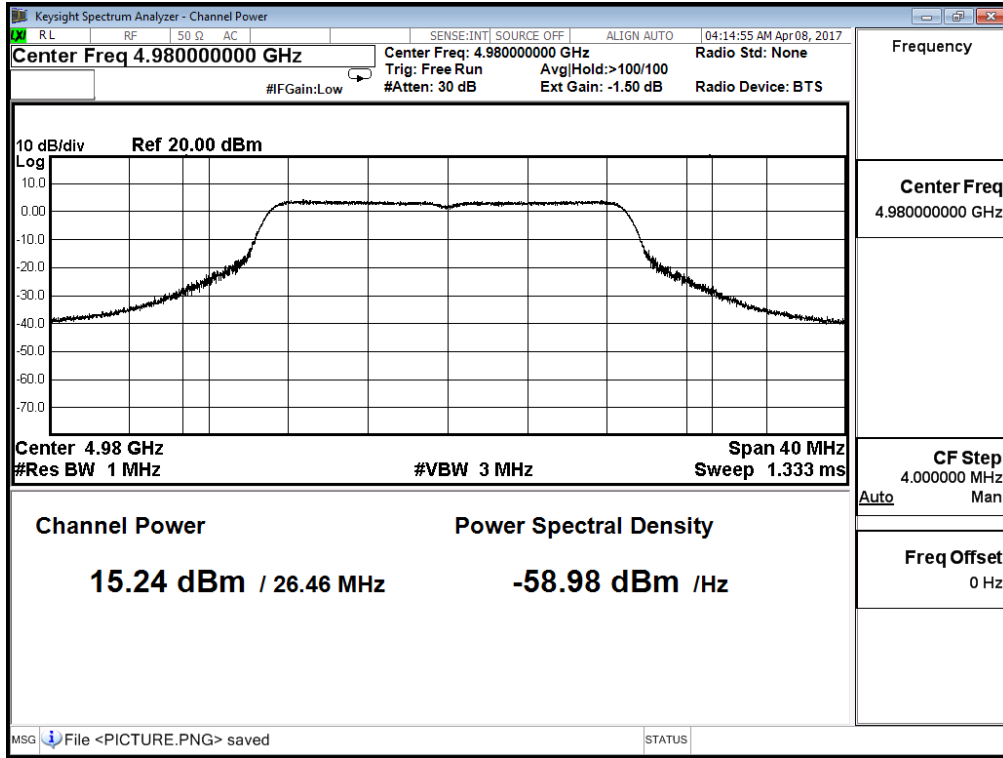

Channel 190 ANT1

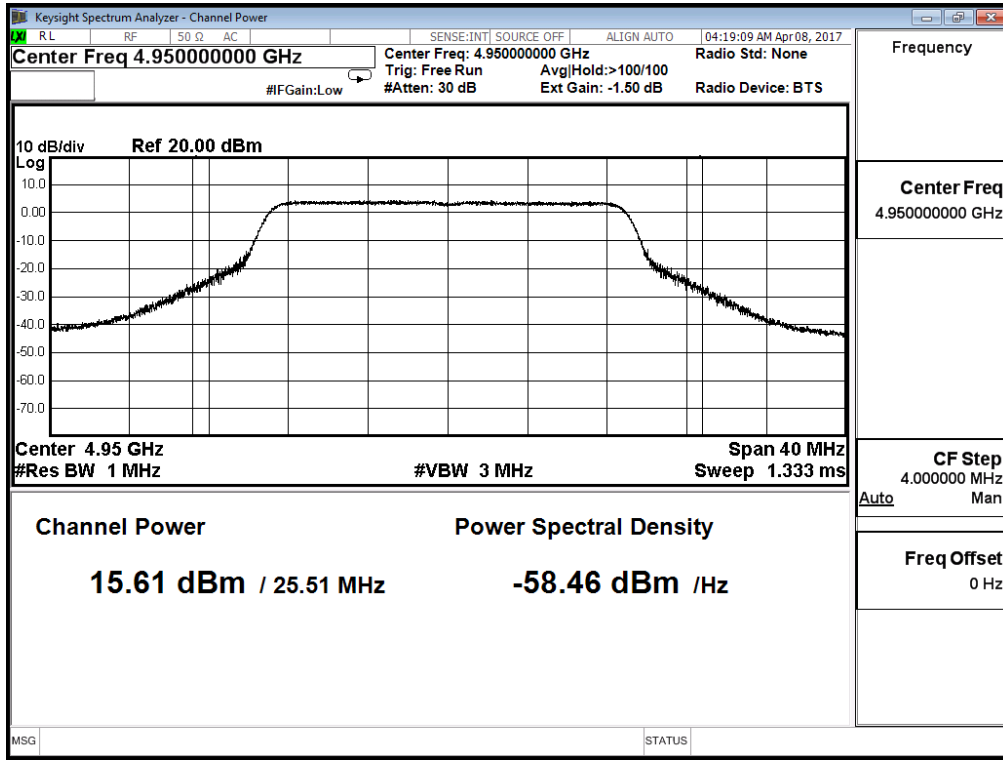

Channel 193 ANT1

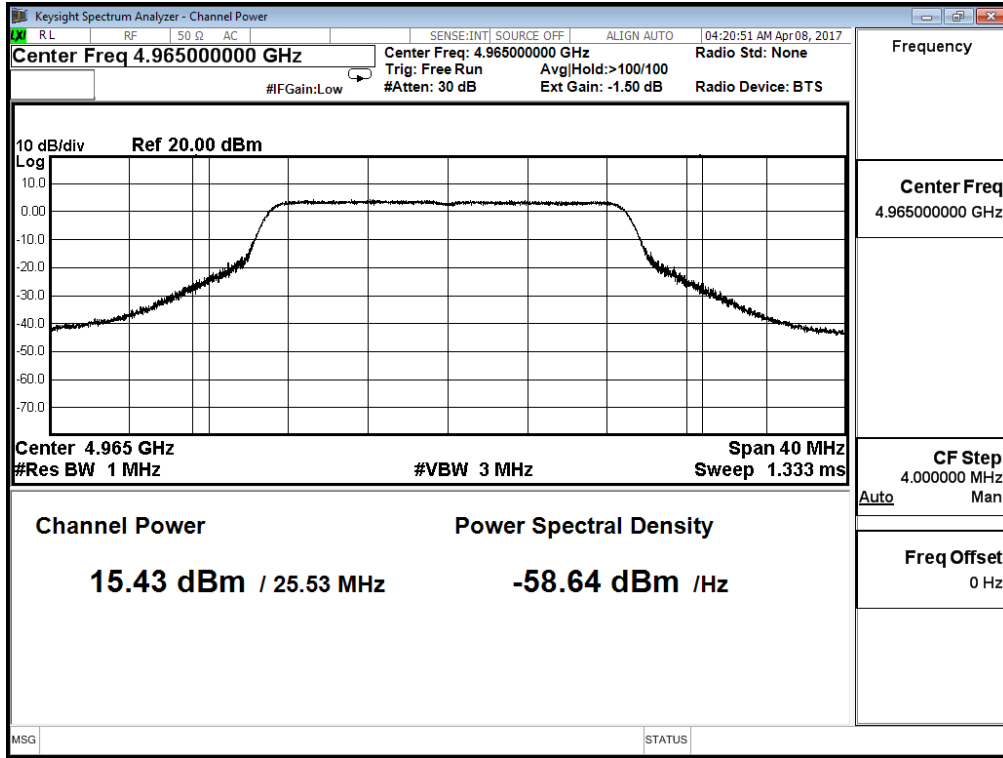

Channel 196 ANT1

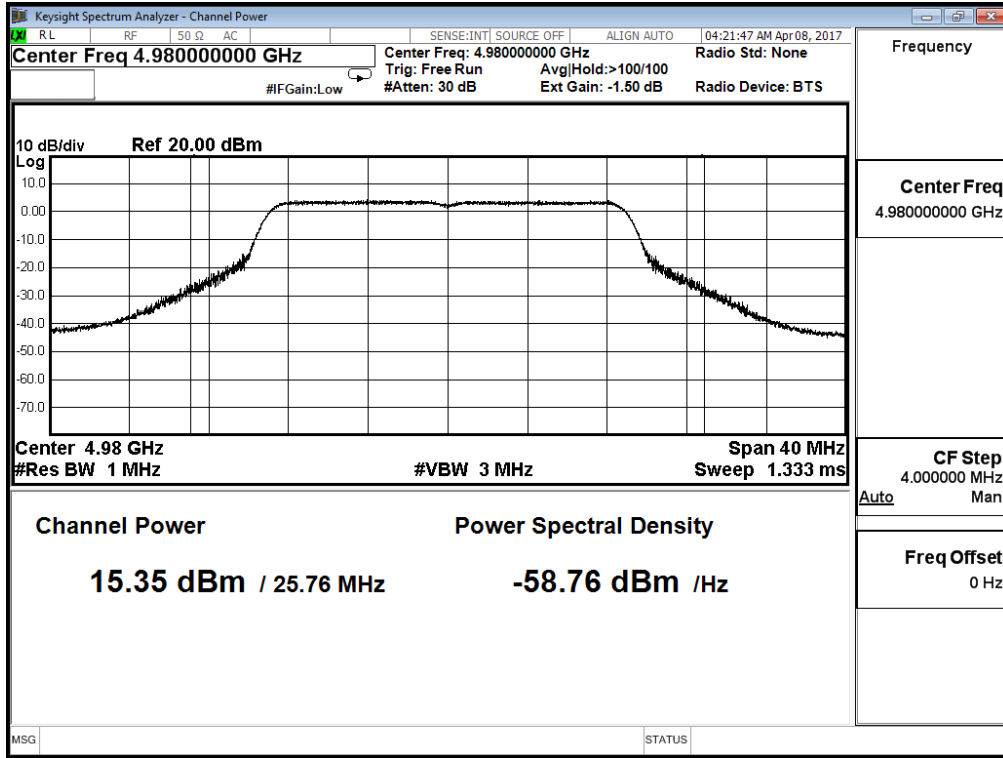

3. Peak Power Spectral Density

3.1. Test Equipment

The following test equipment's are used during the radiated emission tests:

Peak Power Spectral Density / SR10-H

Instrument	Manufacturer	Model No.	Serial No	Next Cal. Date
Spectrum Analyzer	Agilent	N9010A	US47140172	2017/08/08

Note: All equipment's that need to calibrate are with calibration period of 1 year.

3.2. Test Setup

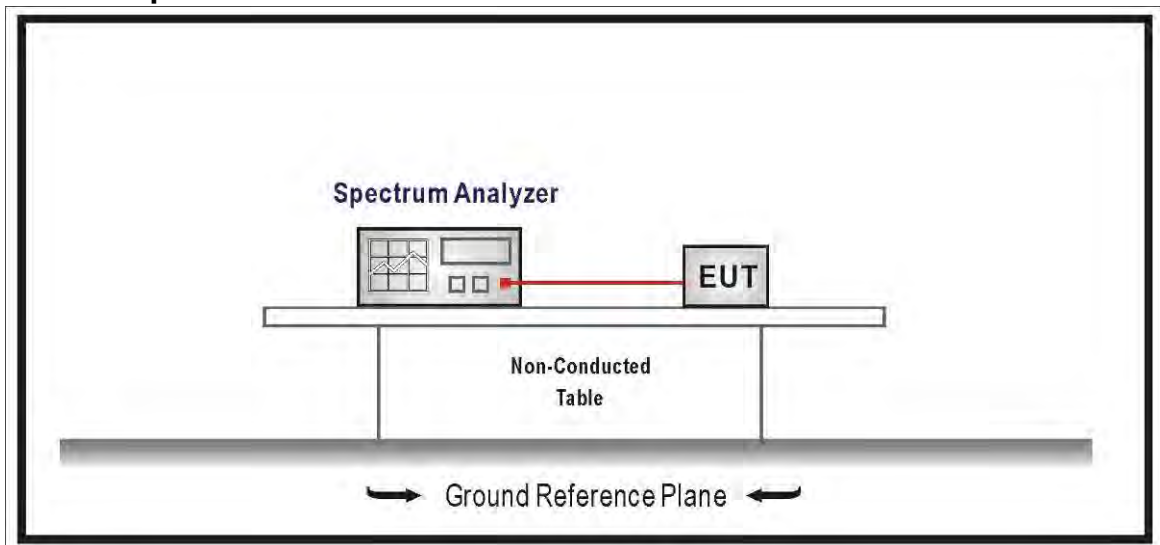

3.3. Limits

(b) Low power devices are also limited to a peak power spectral density of 8 dBm per one MHz. Low power devices using channel bandwidths other than those listed above are permitted; however, they are limited to a peak power spectral density of 8 dBm/MHz. If transmitting antennas of directional gain greater than 9 dBi are used, both the maximum conducted output power and the peak power spectral density should be reduced by the amount in decibels that the directional gain of the antenna exceeds 9 dBi.

(c) The maximum conducted output power is measured as a conducted emission over any interval of continuous transmission using instrumentation calibrated in terms of an RMS-equivalent voltage. If the device cannot be connected directly, alternative techniques acceptable to the Commission may be used. The measurement results shall be properly adjusted for any instrument limitations, such as detector response times, limited resolution bandwidth capability when compared to the emission bandwidth, sensitivity, etc., so as to obtain a true maximum conducted output power measurement conforming to the definitions in this paragraph for the emission in question

Low power maximum conducted output power (dBm/MHz) Density Limit	High power maximum conducted output power (dBm/MHz) Density Limit
8	21

3.4. Test Procedure

The EUT transmitter output was connected through the appropriate 50-ohm attenuator to a spectrum analyzer. Resolution bandwidth was set to 1% of occupied bandwidth and video bandwidth was set to a value greater than the resolution bandwidth. Peak search was used to find peak spectral density within 5 or 10 MHz signal bandwidth and centered within the 1 MHz span of measurement; the spectrum analyzer integrated measurement plot was taken.

3.5. Uncertainty

± 1.62 dB

3.6. Test Result

Product	Mimosa C5c		
Test Item	Peak Power Spectral Density		
Test Mode	Mode 1: Transmit-Dish		
Date of Test	2017/04/13	Test Site	SR10-H

Peak Power Spectral Density

Channel	Frequency (MHz)	ANT0 (dBm/MHz)	ANT1 (dBm/MHz)	ANT0+1 (dBm/MHz)	Limit (dBm/MHz)	Test Result
190	4950	-12.569	-12.136	-9.337	< -9	Pass
193	4965	-12.446	-12.045	-9.231		
196	4980	-12.285	-12.081	-9.172		

Antenna gain = 26 dBi

Reduced Power Density Limit = Original Power Density Limit – (Antenna Gain – 9 dBi) = -9 dBm/MHz

Channel 190 ANT0

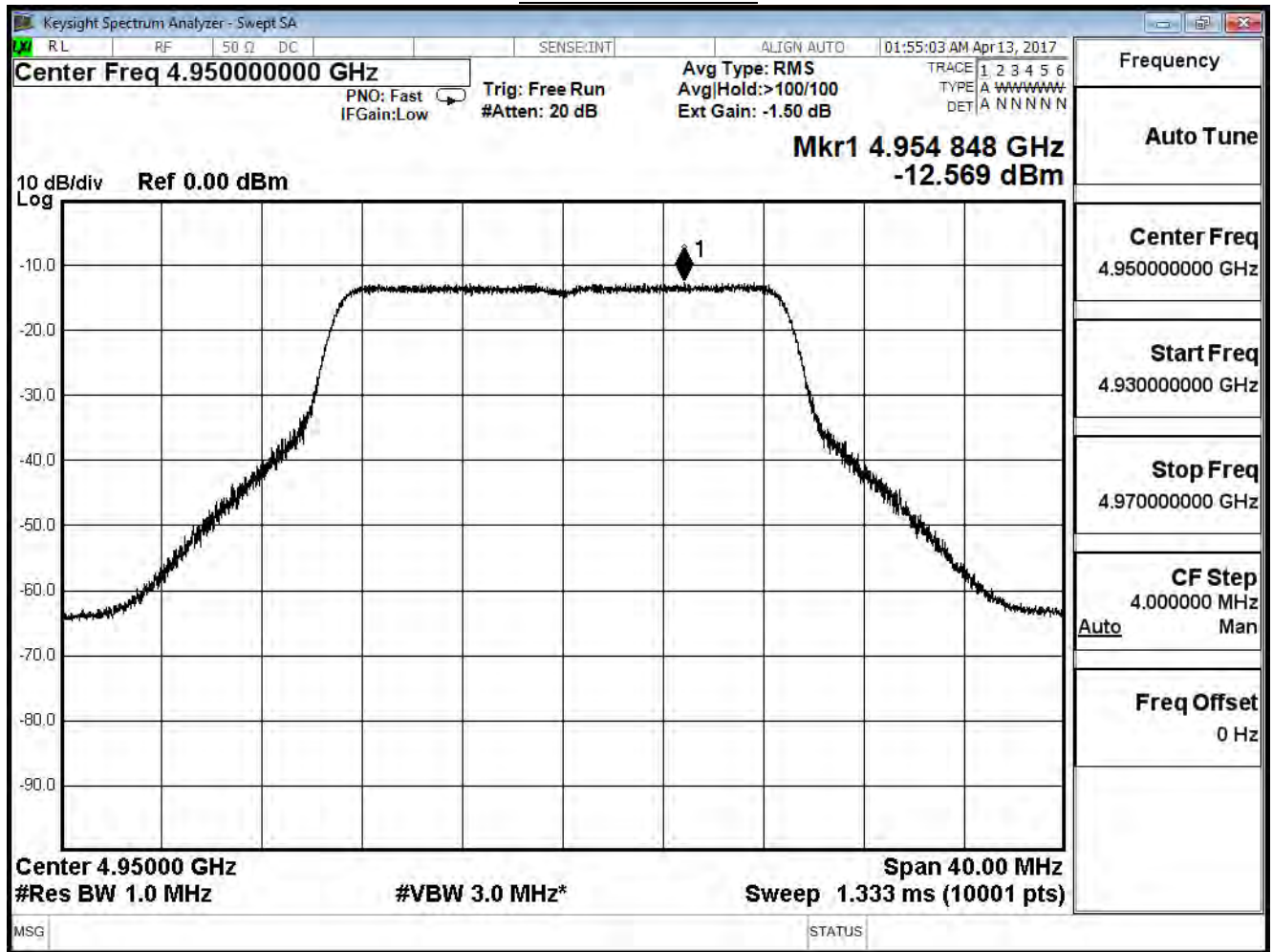

Channel 193 ANT0

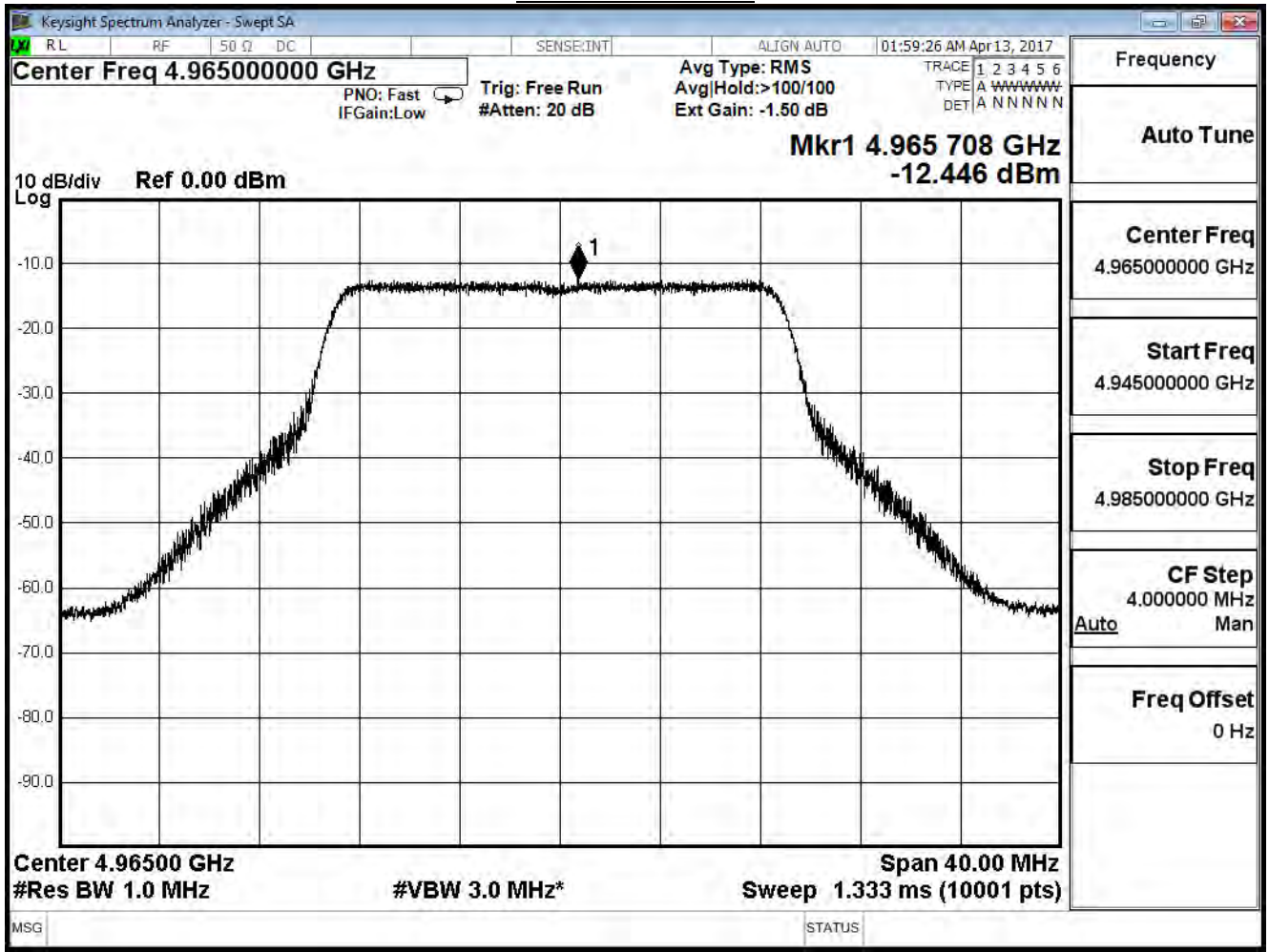

Channel 196 ANT0

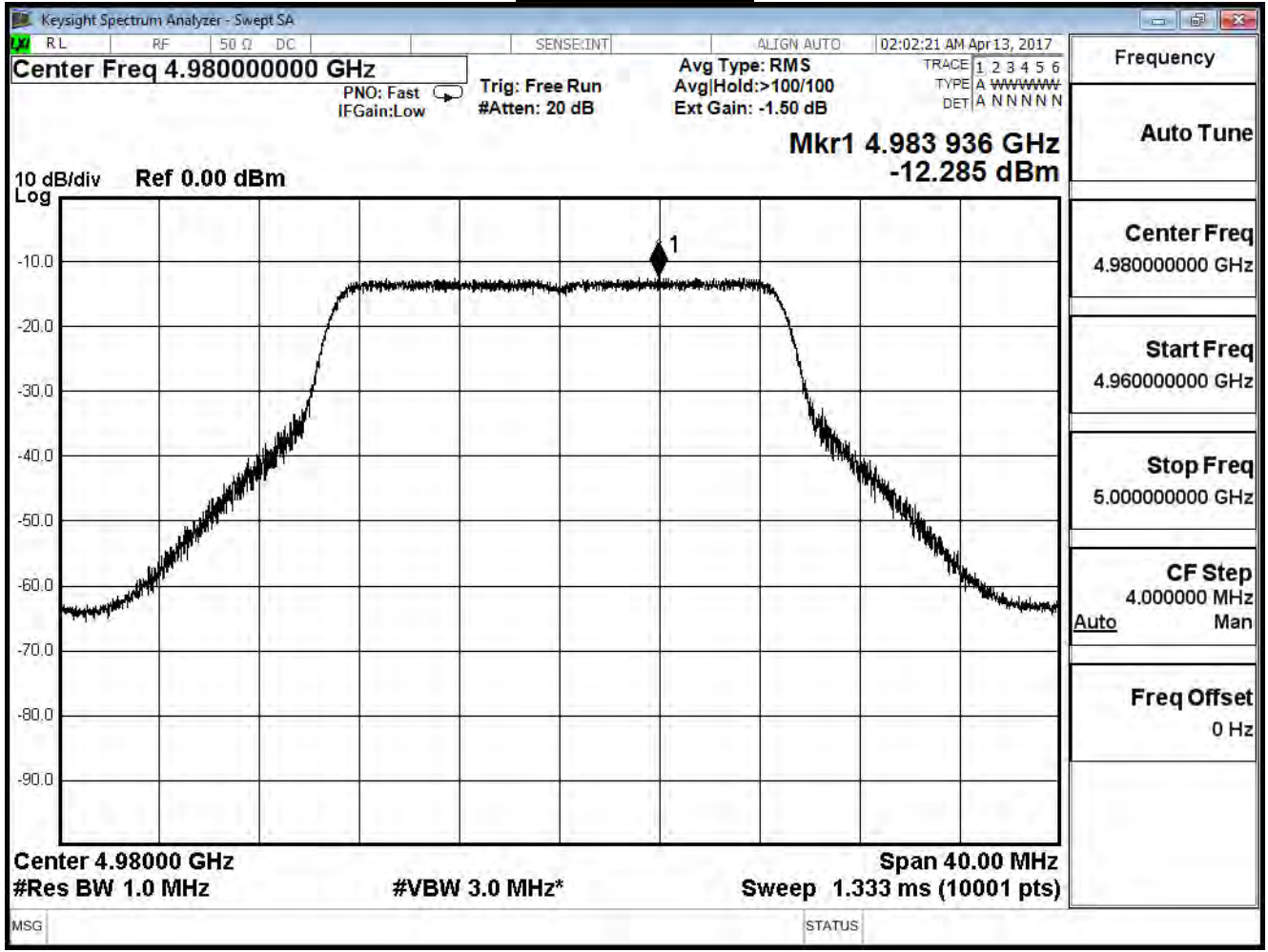

Channel 190 ANT1

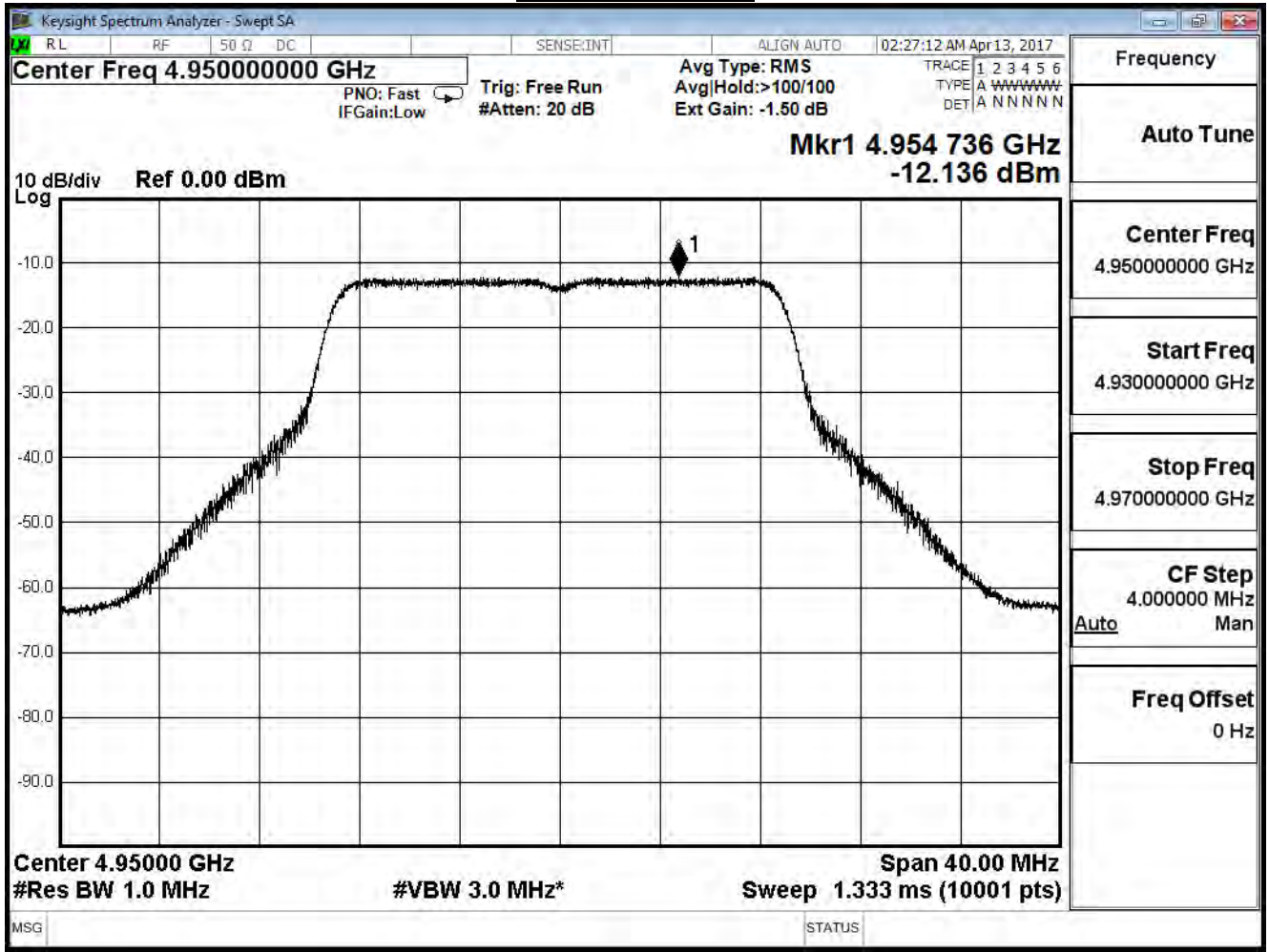

Channel 193 ANT1

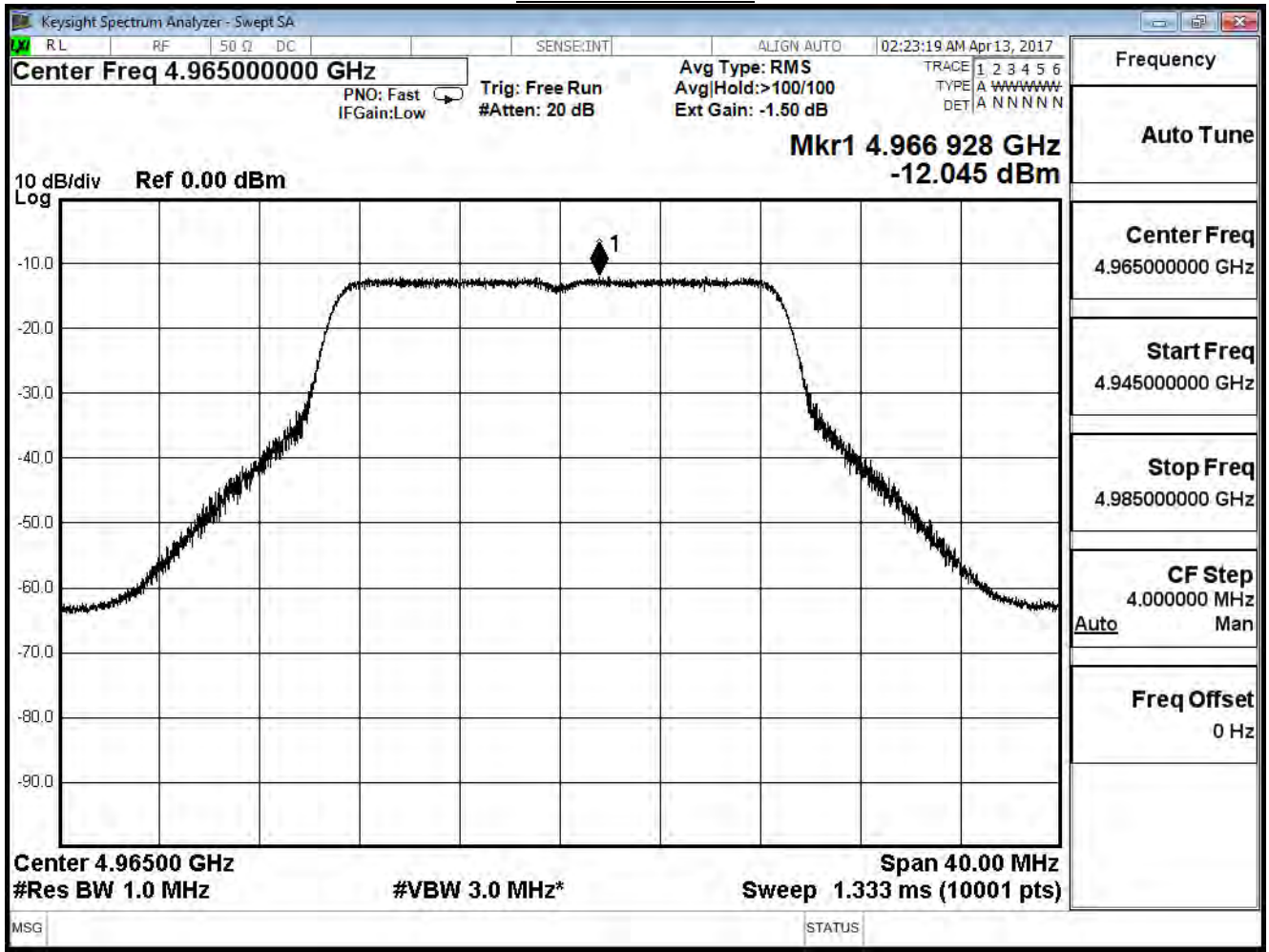

Channel 196 ANT1

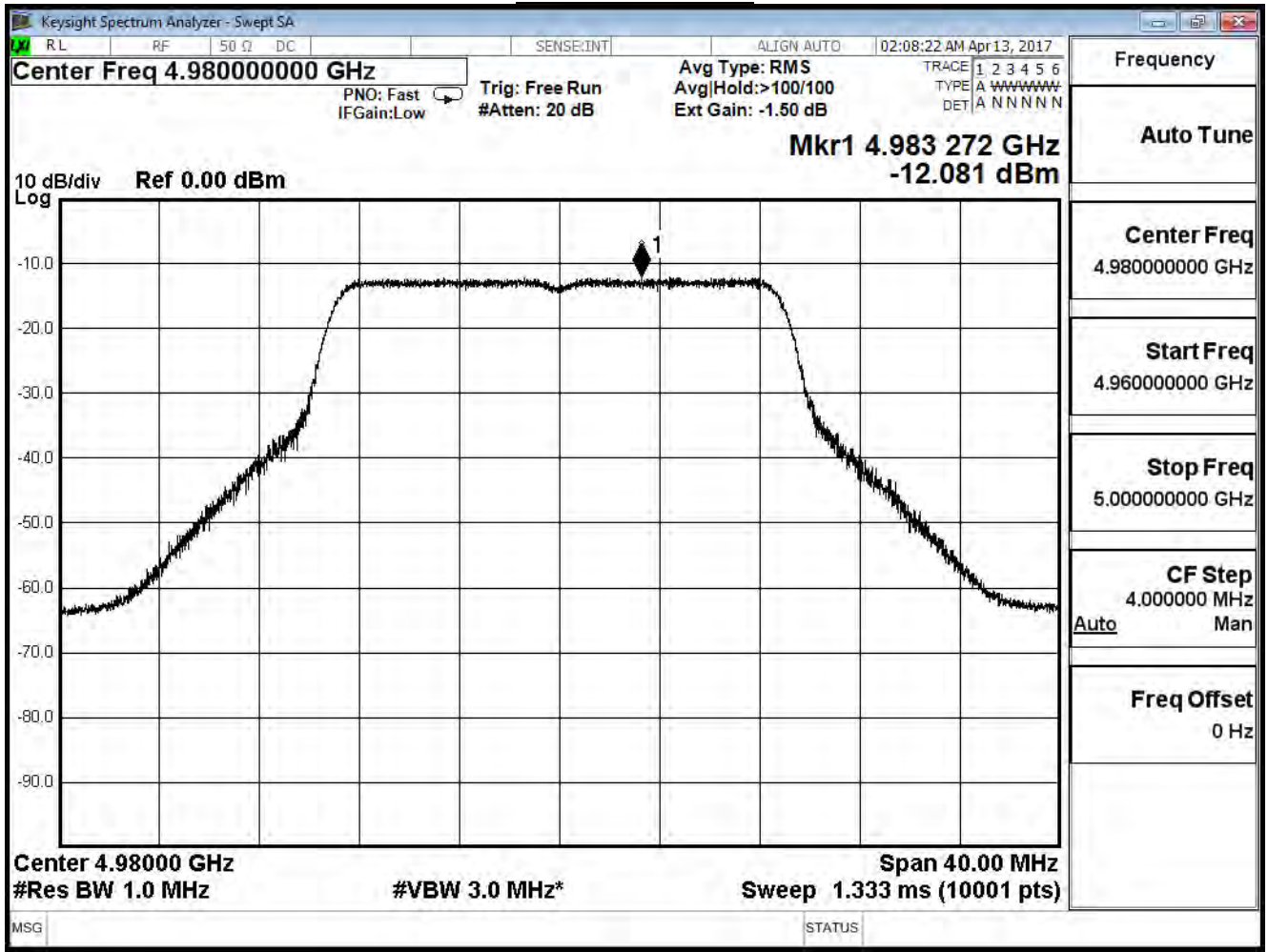

Product	Mimosa C5c		
Test Item	Peak Power Spectral Density		
Test Mode	Mode 2: Transmit-Dipole		
Date of Test	2017/04/08	Test Site	SR10-H

Peak Power Spectral Density

Channel	Frequency (MHz)	ANT0 (dBm/MHz)	ANT1 (dBm/MHz)	ANT0+1 (dBm/MHz)	Limit (dBm/MHz)	Test Result
190	4950	4.457	4.465	7.471	<8	Pass
193	4965	4.348	4.209	7.289		
196	4980	4.297	4.257	7.287		

Channel 190 ANT0

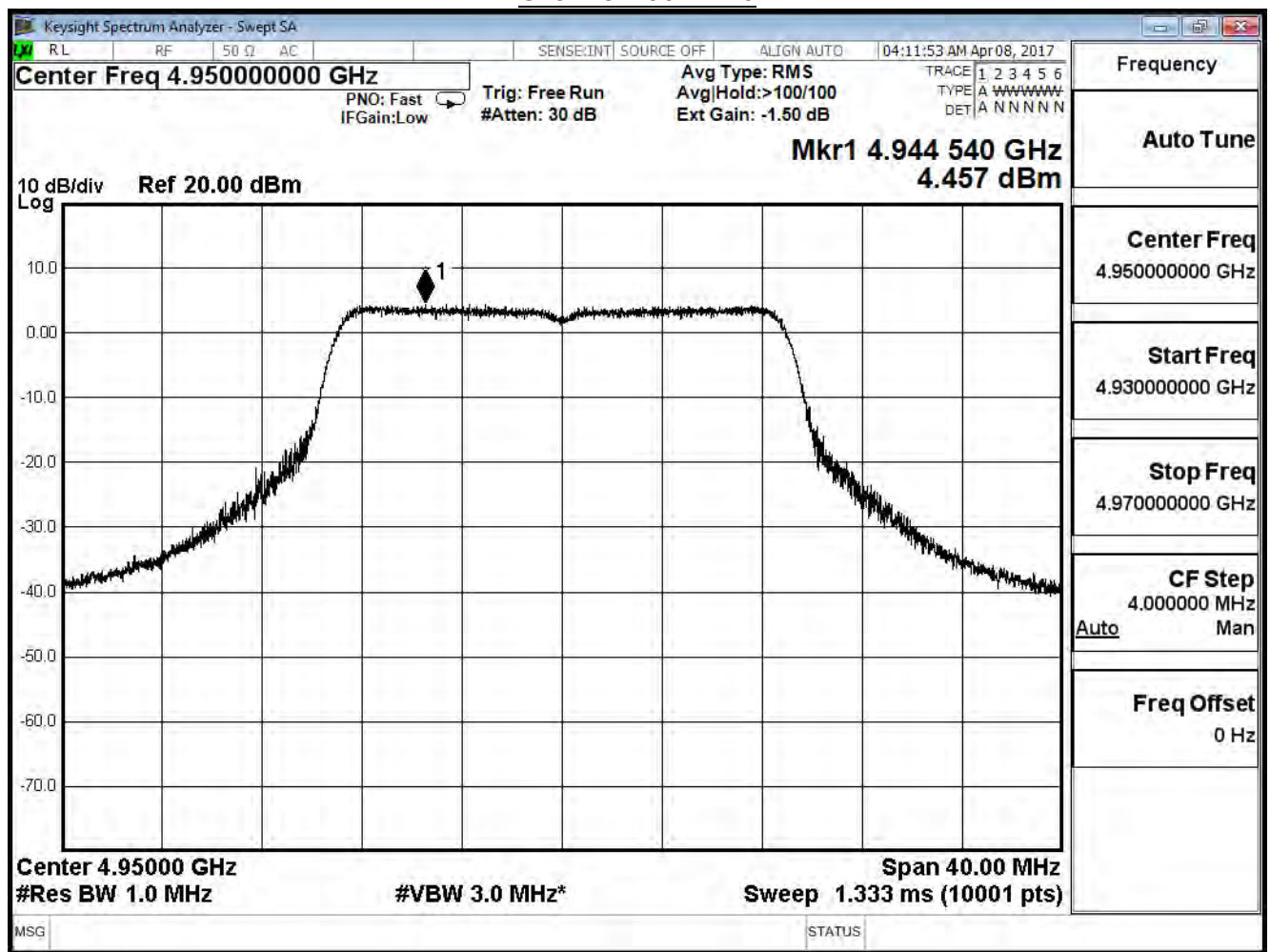

Channel 193 ANT0

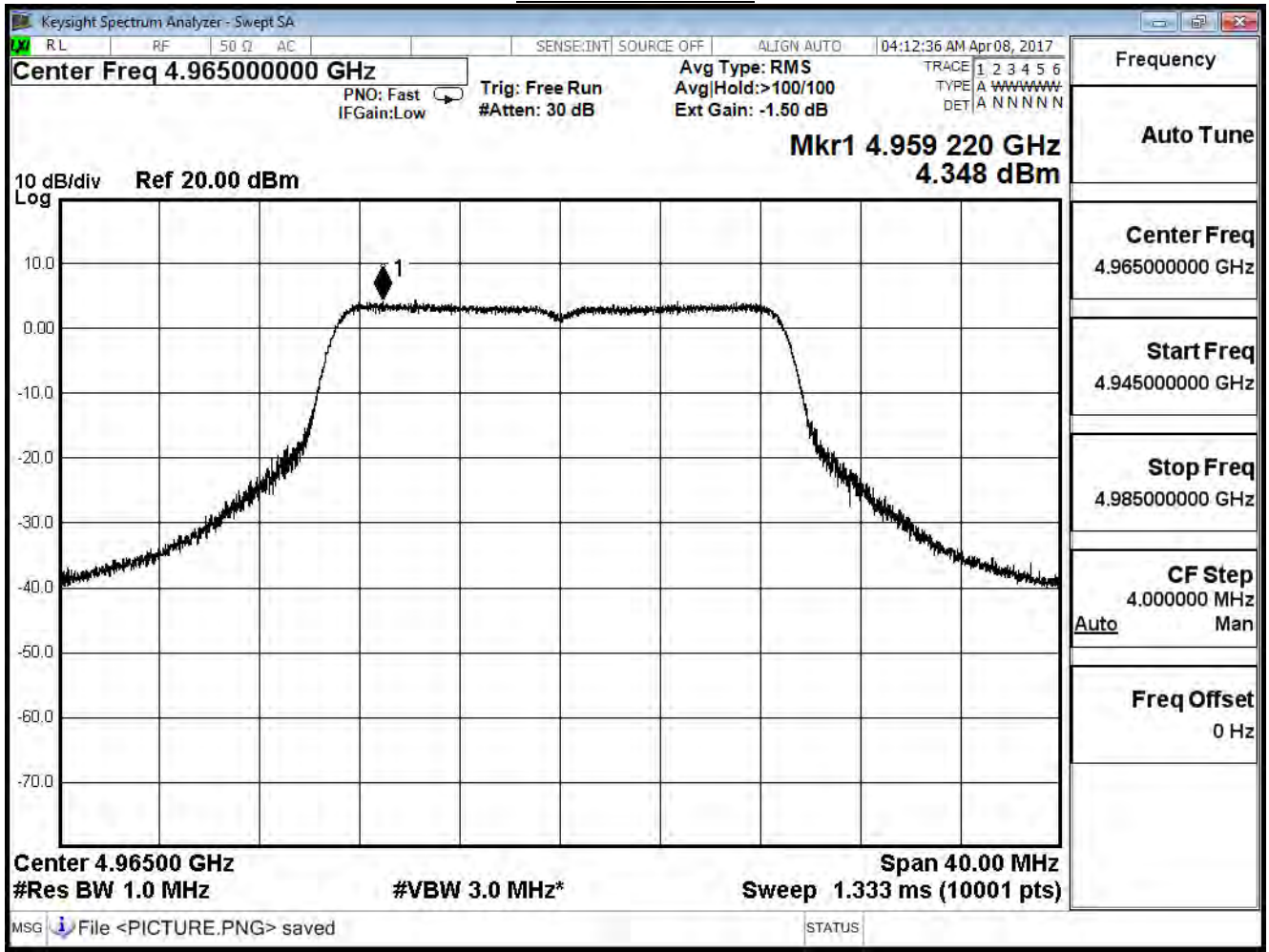

Channel 196 ANT0

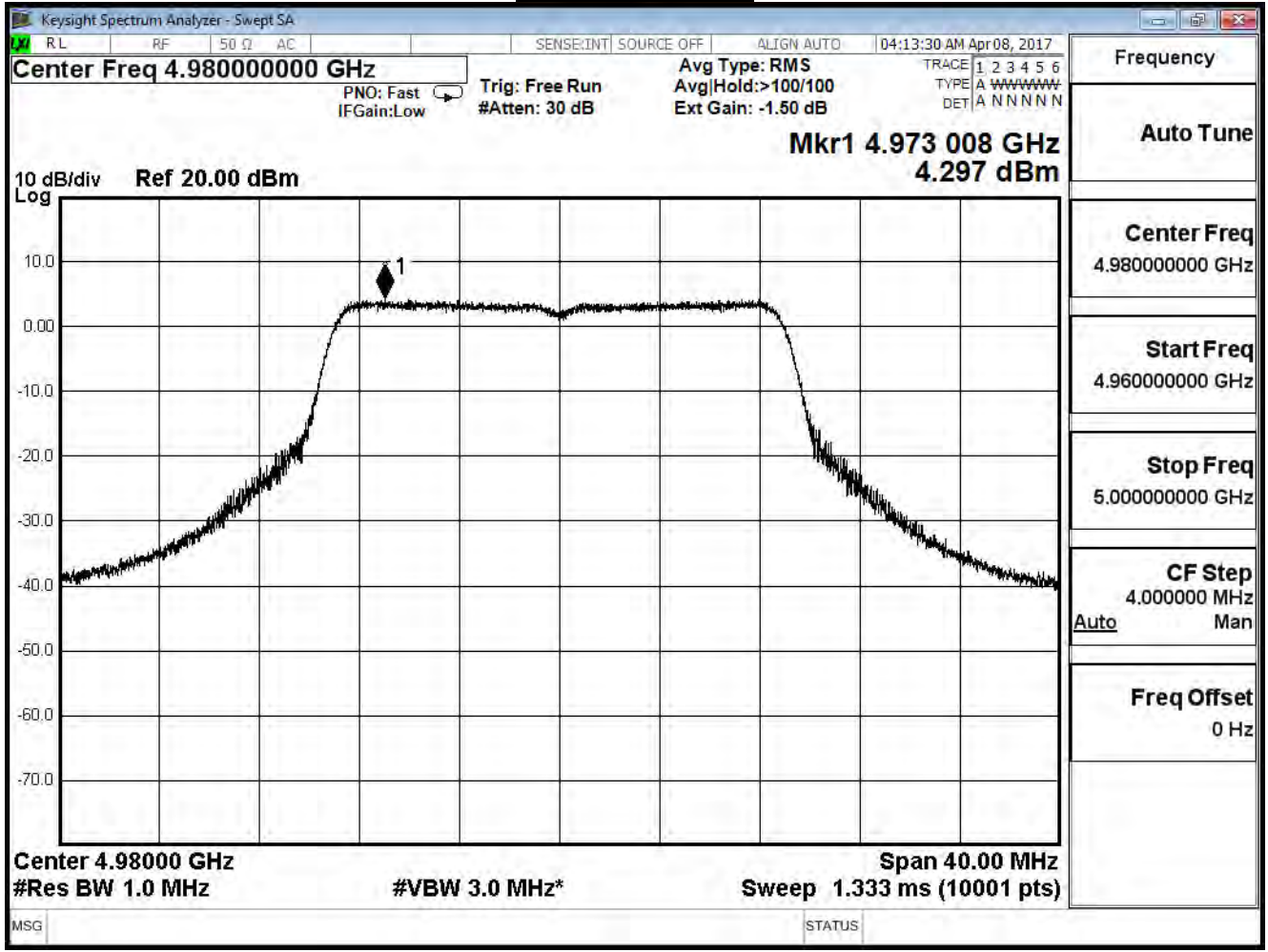

Channel 190 ANT1

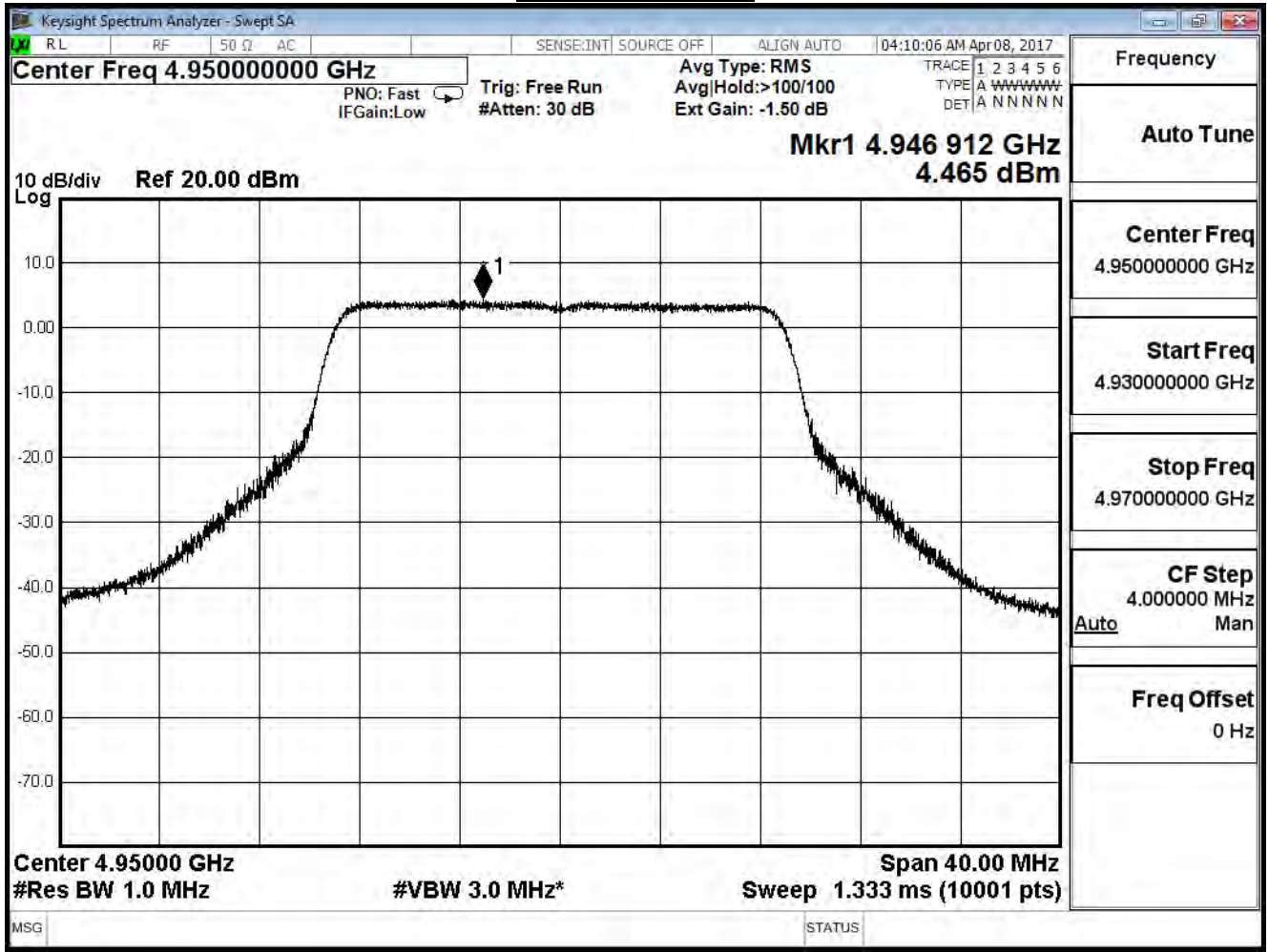

Channel 193 ANT1

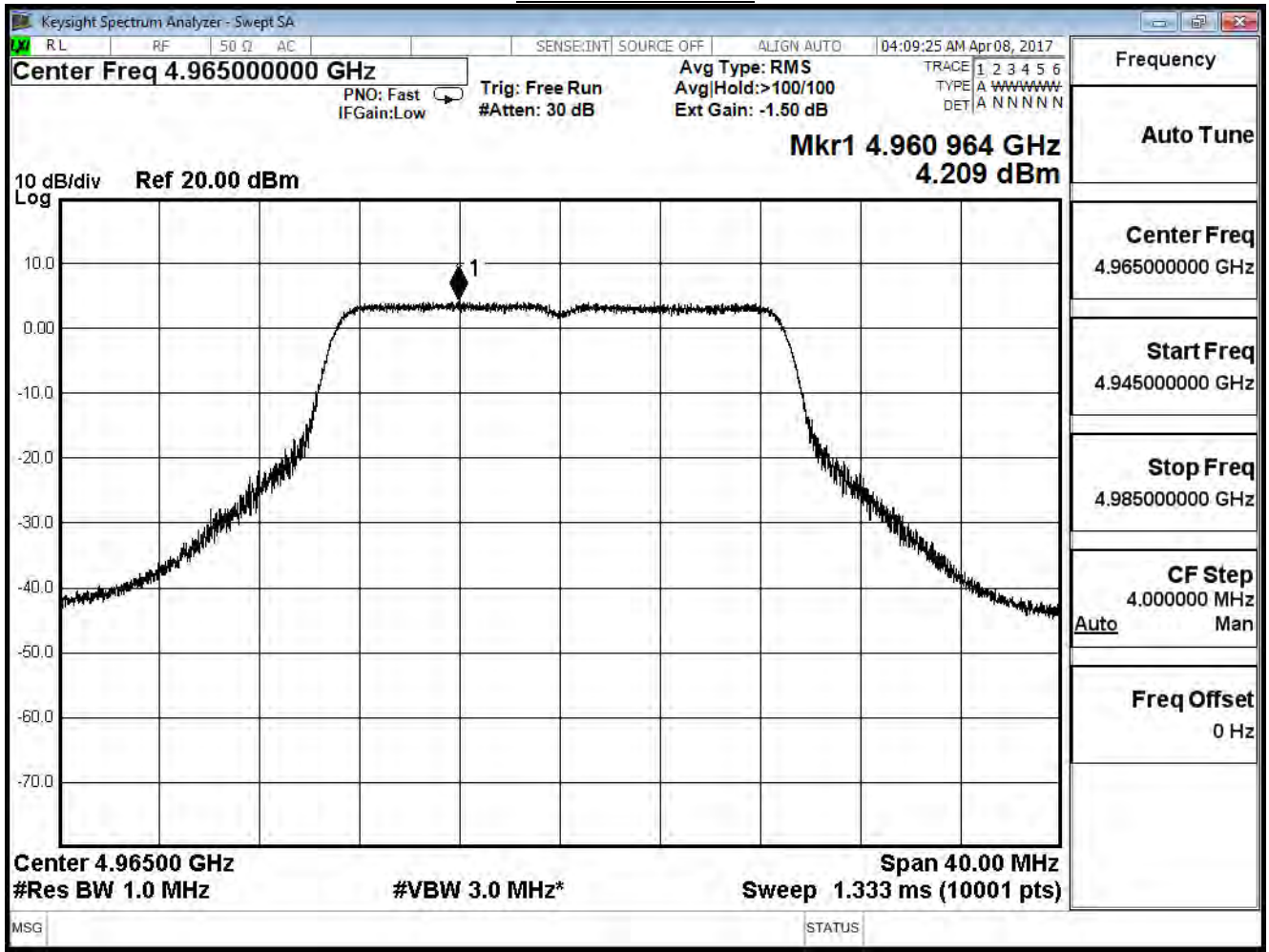

Channel 196 ANT1

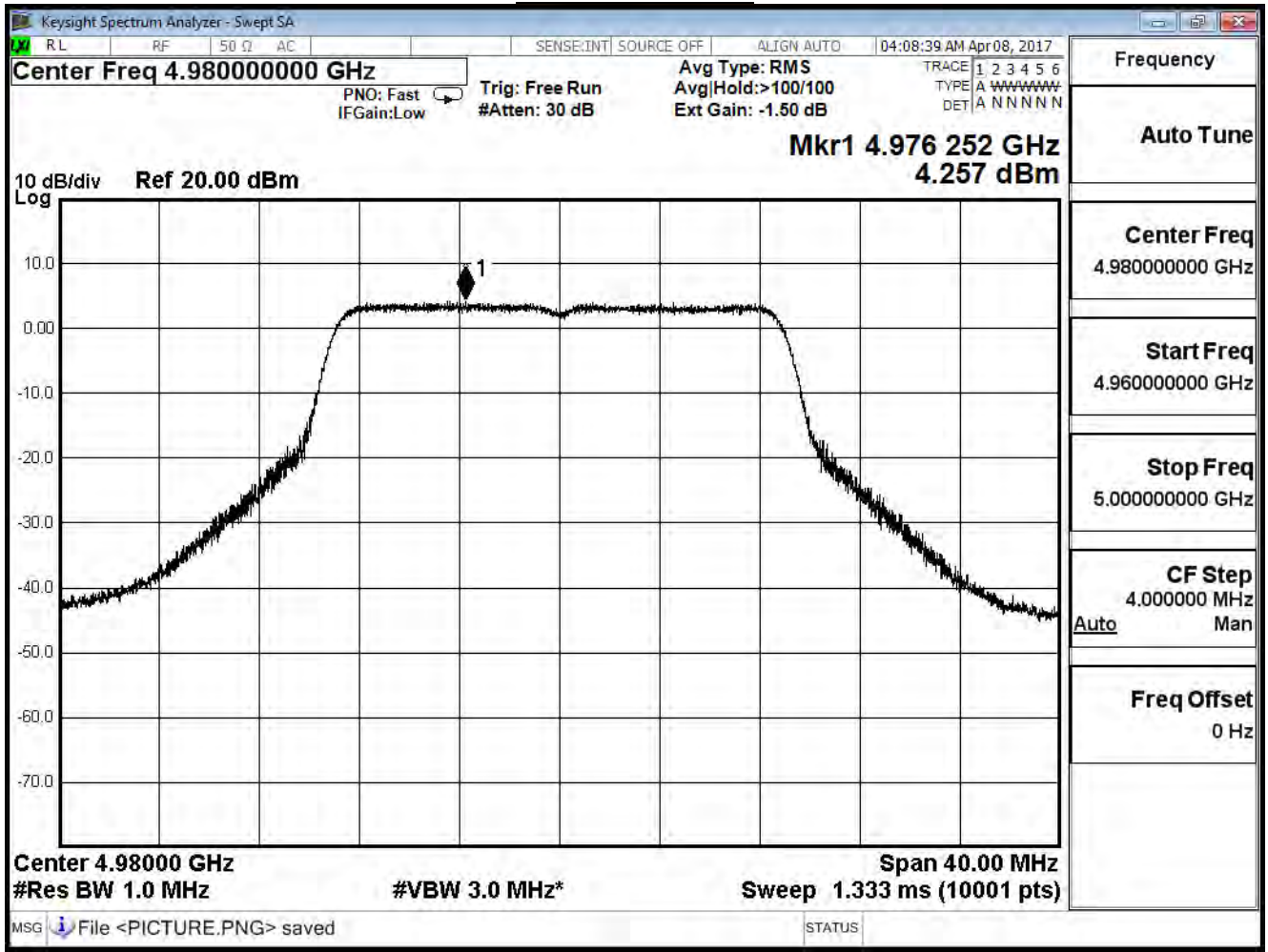

4. Occupied Bandwidth

4.1. Test Equipment

The following test equipment's are used during the radiated emission tests:

Occupied Bandwidth / SR10-H

Instrument	Manufacturer	Model No.	Serial No	Next Cal. Date
Spectrum Analyzer	Agilent	N9010A	US47140172	2017/08/08

Note: All equipment's that need to calibrate are with calibration period of 1 year.

4.2. Test Setup

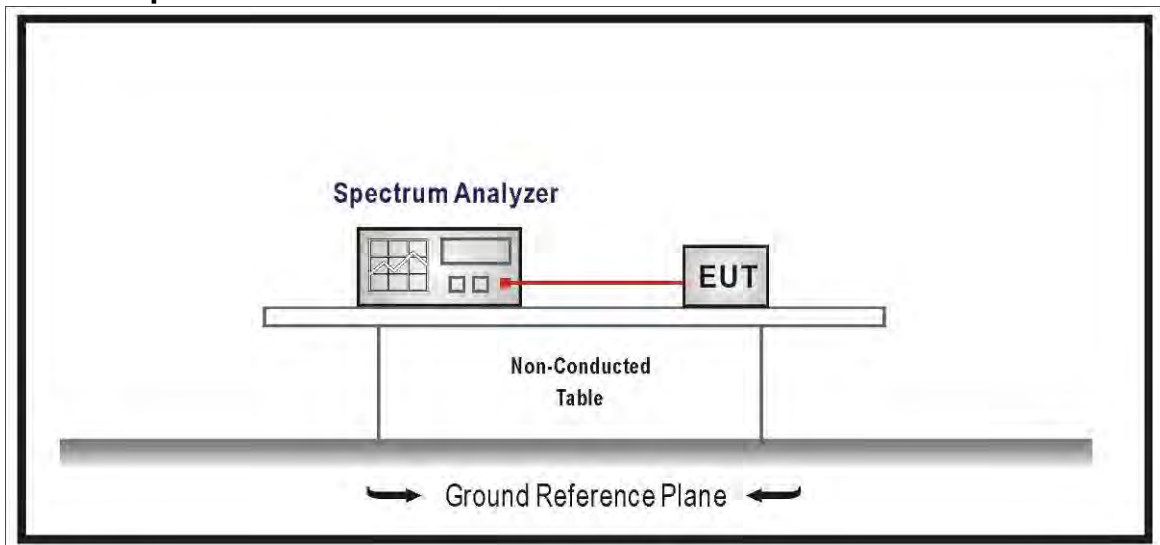

4.3. Limits

No Required

4.4. Uncertainty

681.6Hz

4.5. Test Result

Product	Mimosa C5c		
Test Item	Occupied Bandwidth		
Test Mode	Mode 1: Transmit-Dish		
Date of Test	2017/03/03	Test Site	SR10-H

Channel	Frequency (MHz)	ANT0 (MHz)	ANT1 (MHz)	Limit	Test Result
190	4950	26.180	25.550	N/A	Pass
193	4965	26.140	25.530		
196	4980	26.140	25.440		

Channel 190 ANT0

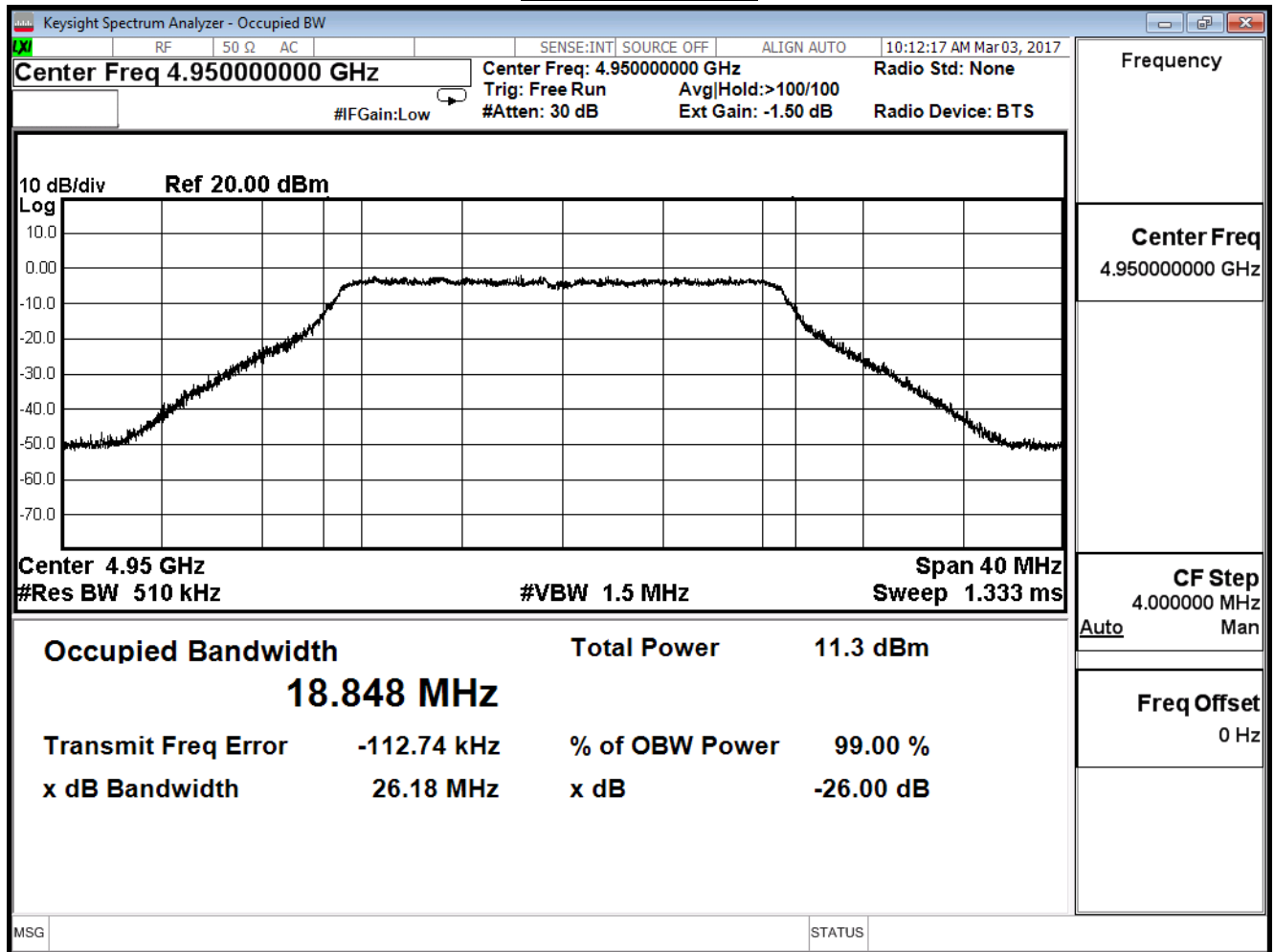

Channel 193 ANT0

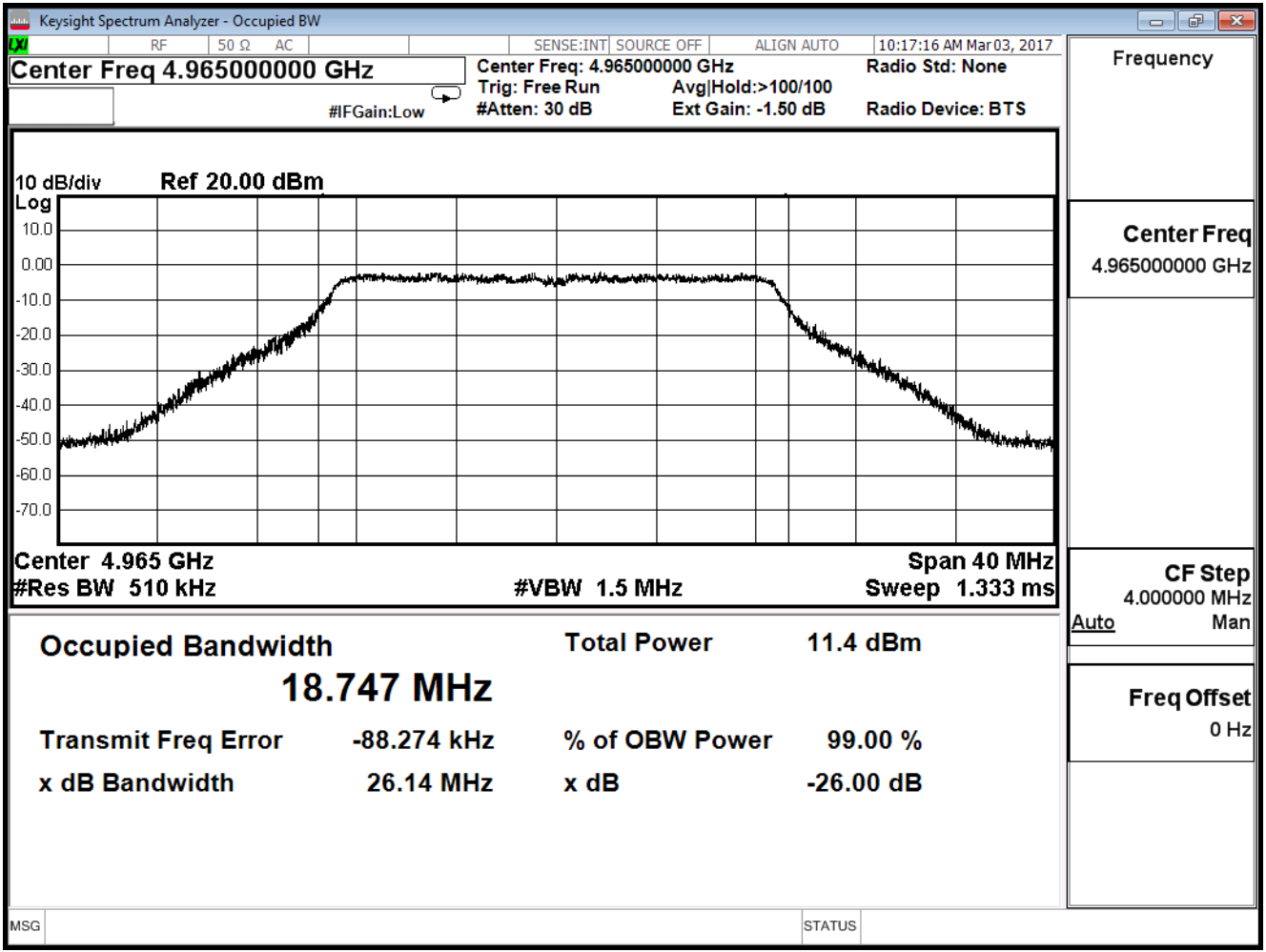

Channel 196 ANT0

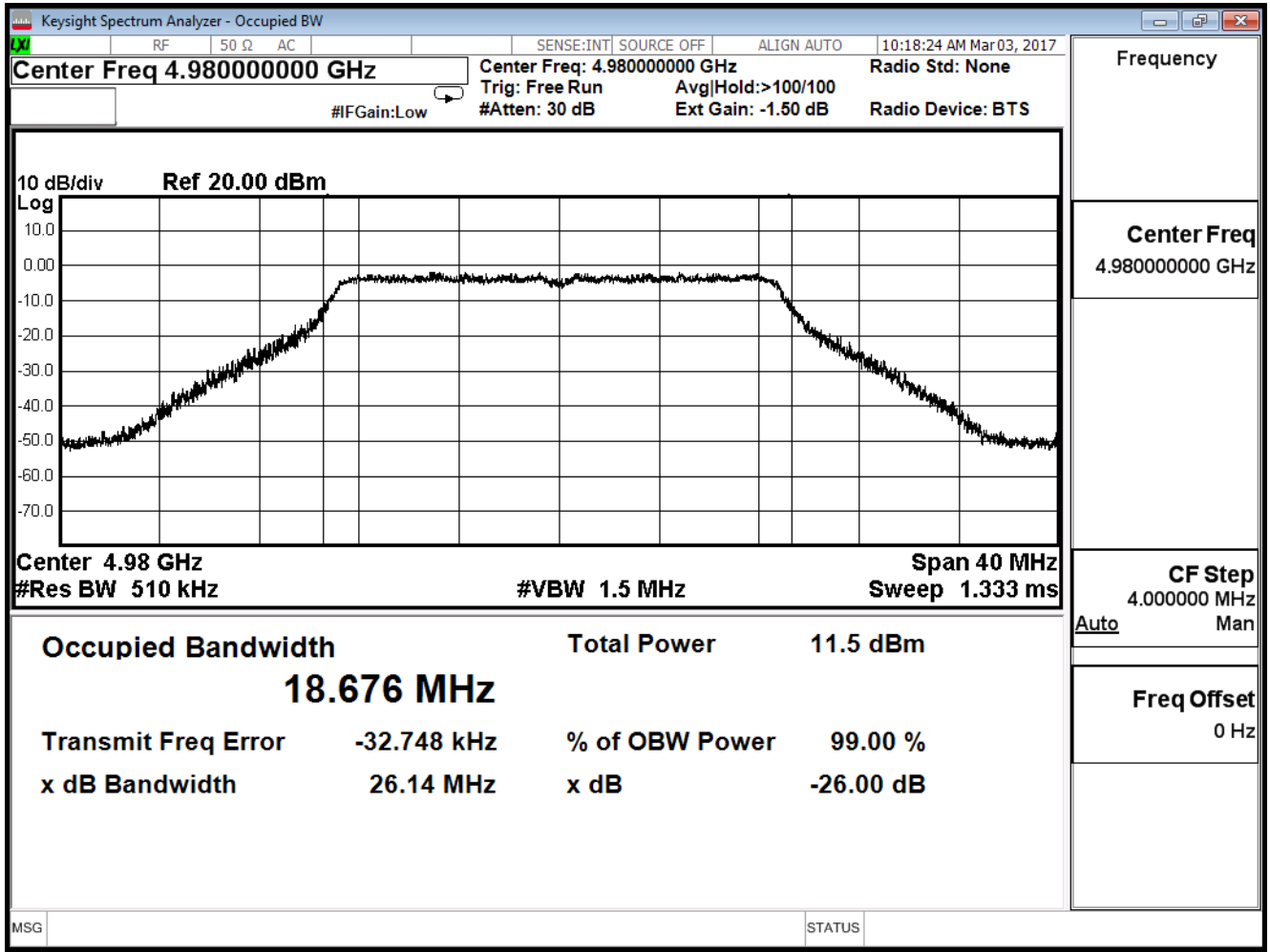

Channel 190 ANT1

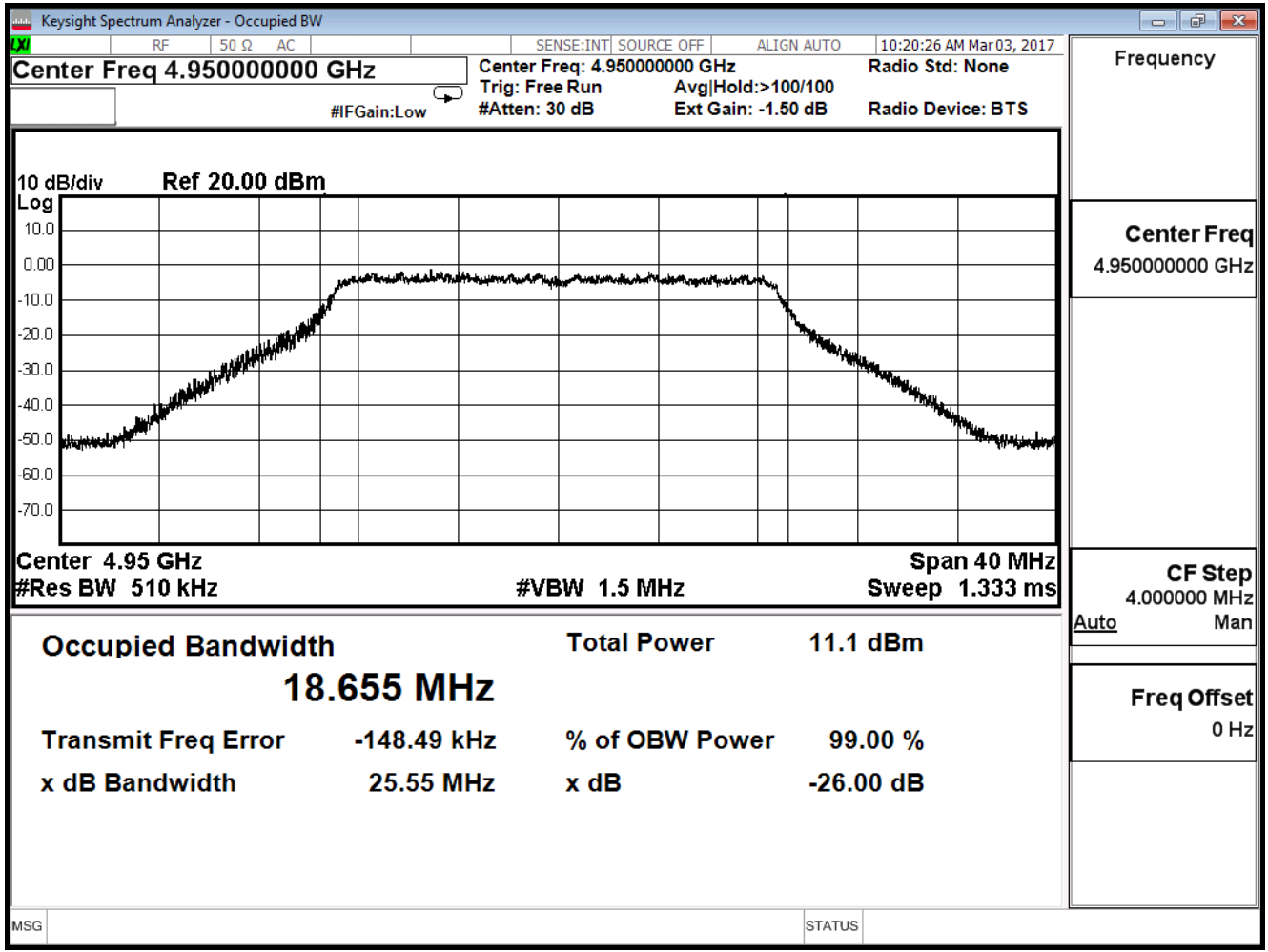

Channel 193 ANT1

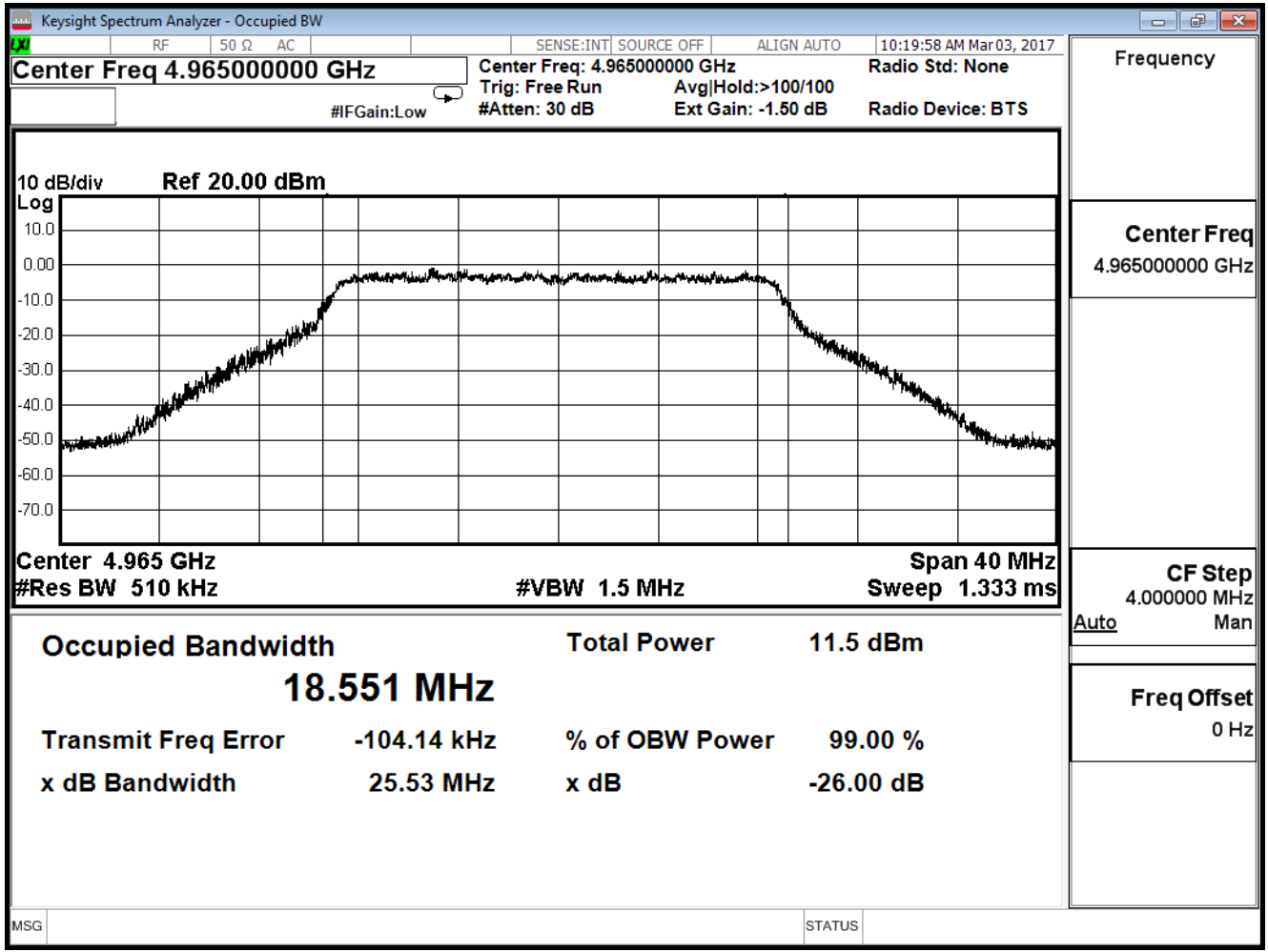

Channel 196 ANT1

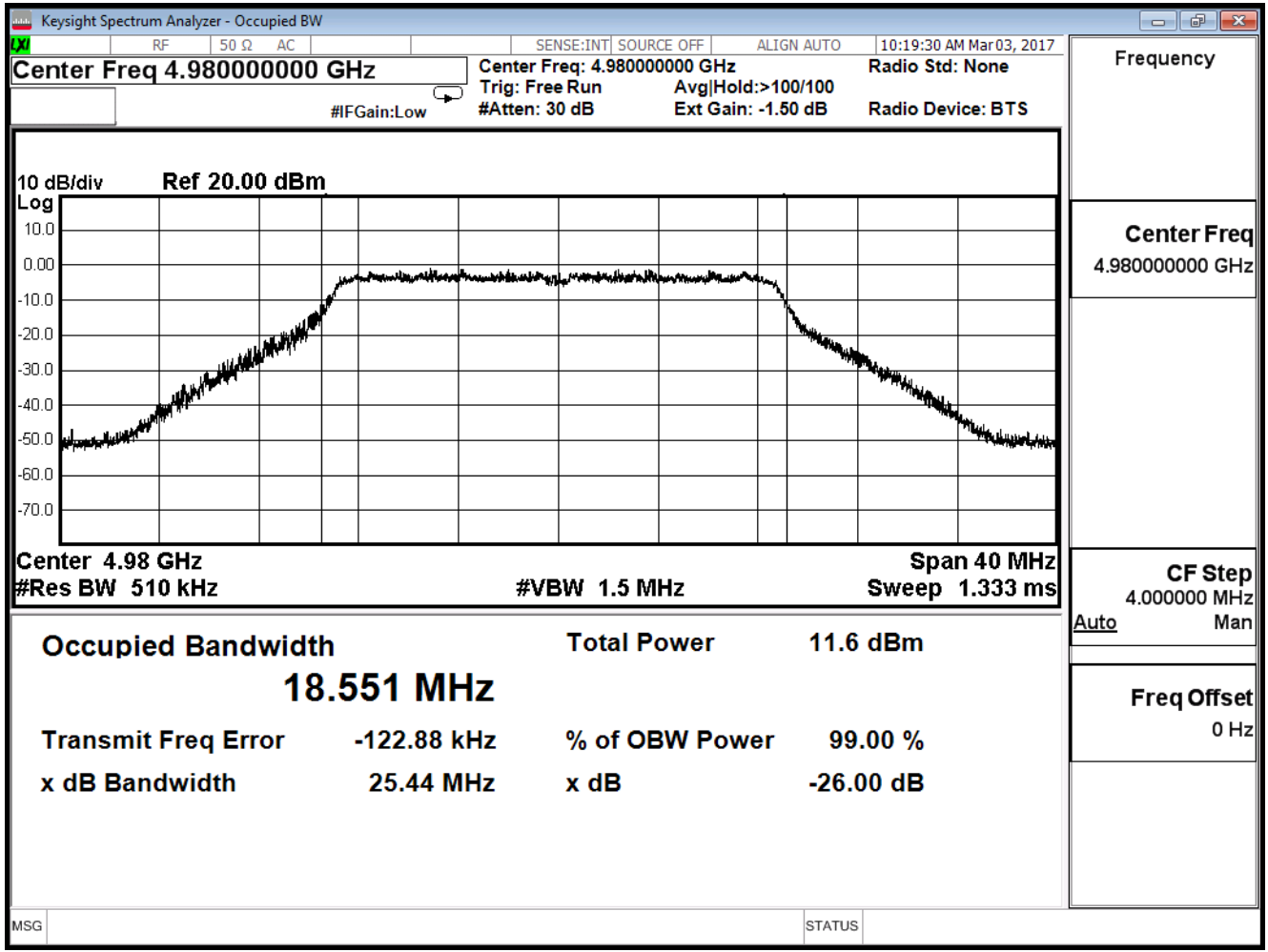

Product	Mimosa C5c		
Test Item	Occupied Bandwidth		
Test Mode	Mode 2: Transmit-Dipole		
Date of Test	2017/03/03	Test Site	SR10-H

Channel	Frequency (MHz)	ANT0 (MHz)	ANT1 (MHz)	Limit	Test Result
190	4950	26.170	25.510	N/A	Pass
193	4965	26.290	25.530		
196	4980	26.460	25.760		

Channel 190 ANT0

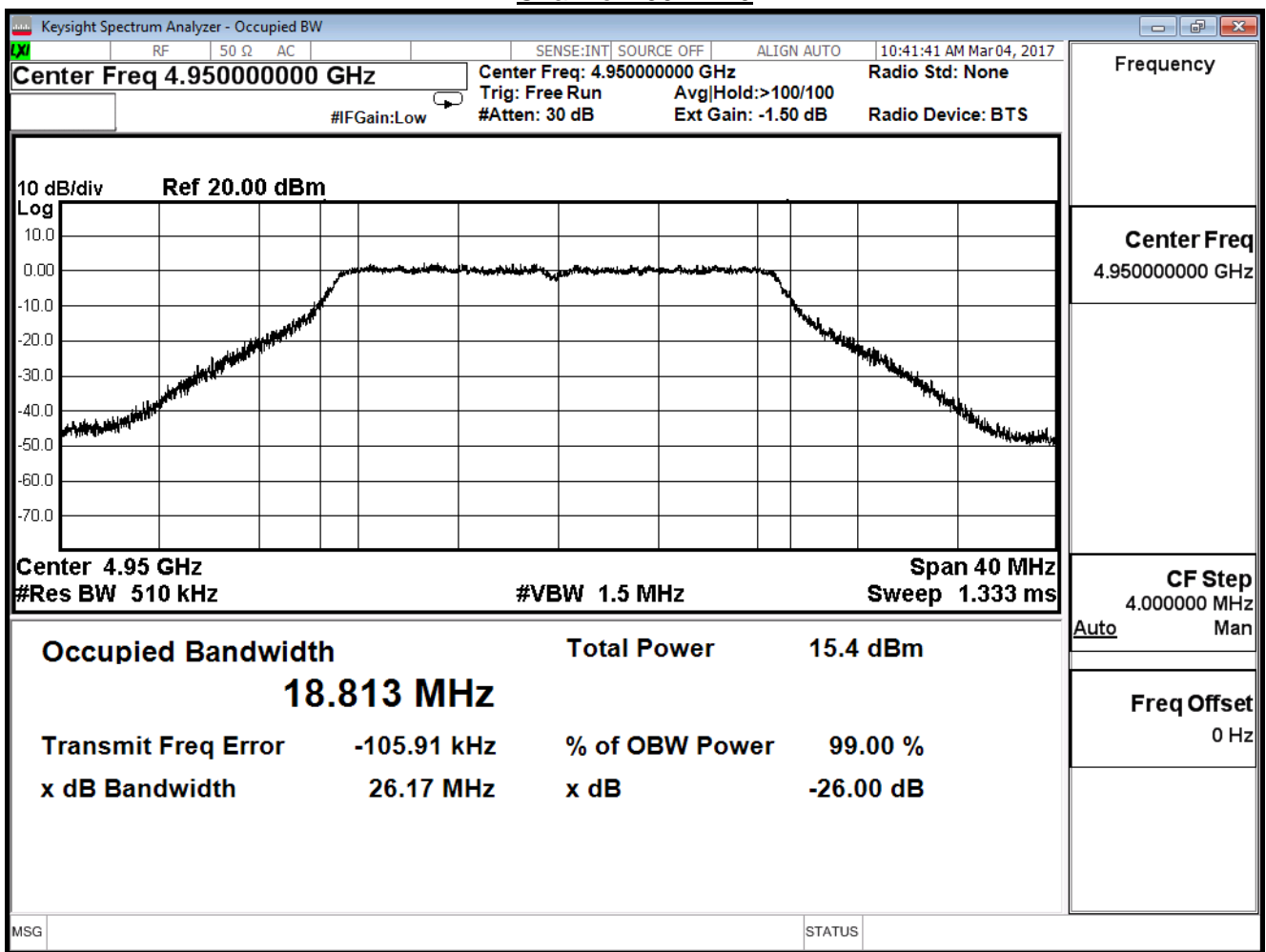

Channel 193 ANT0

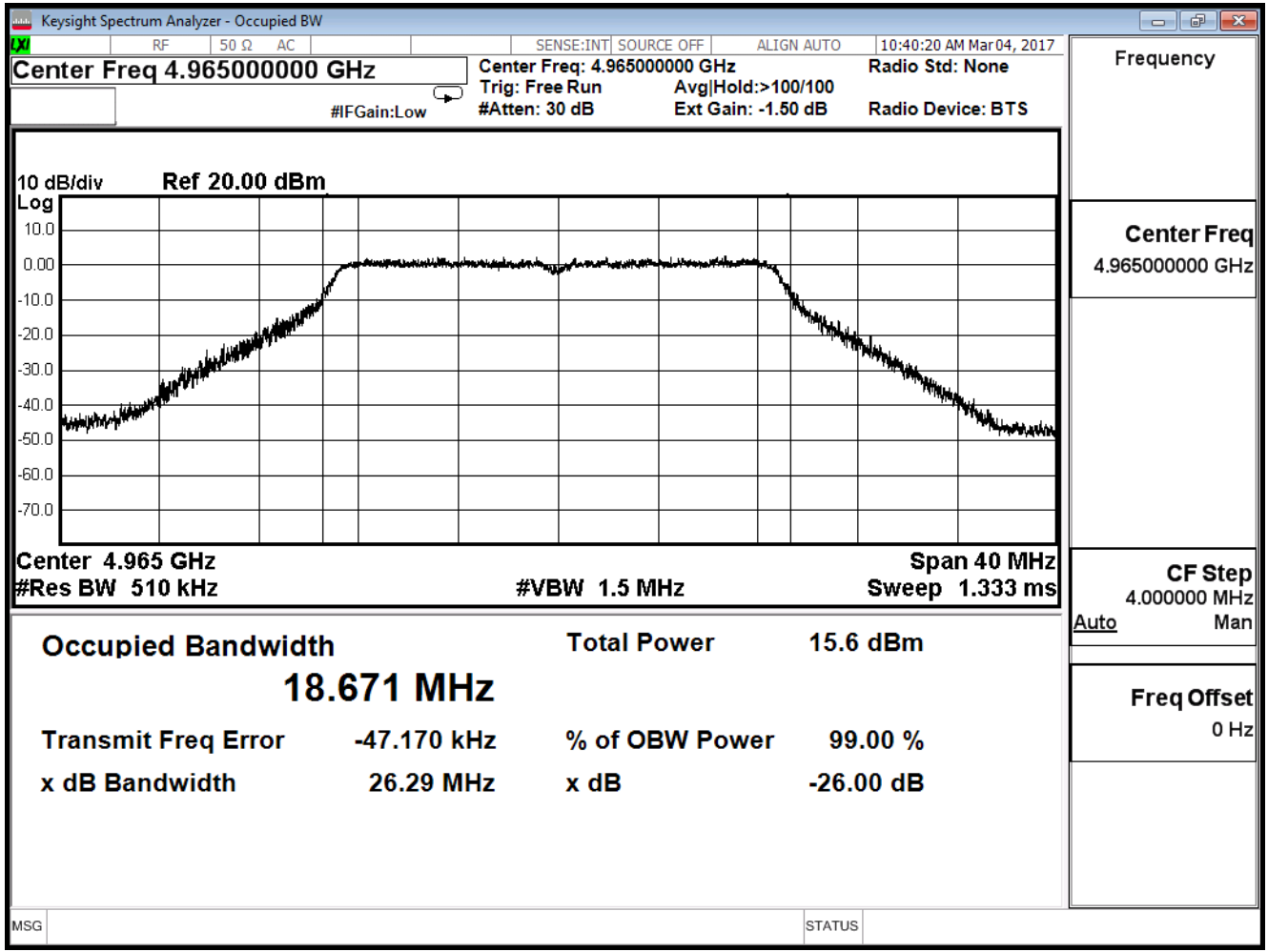

Channel 196 ANT0

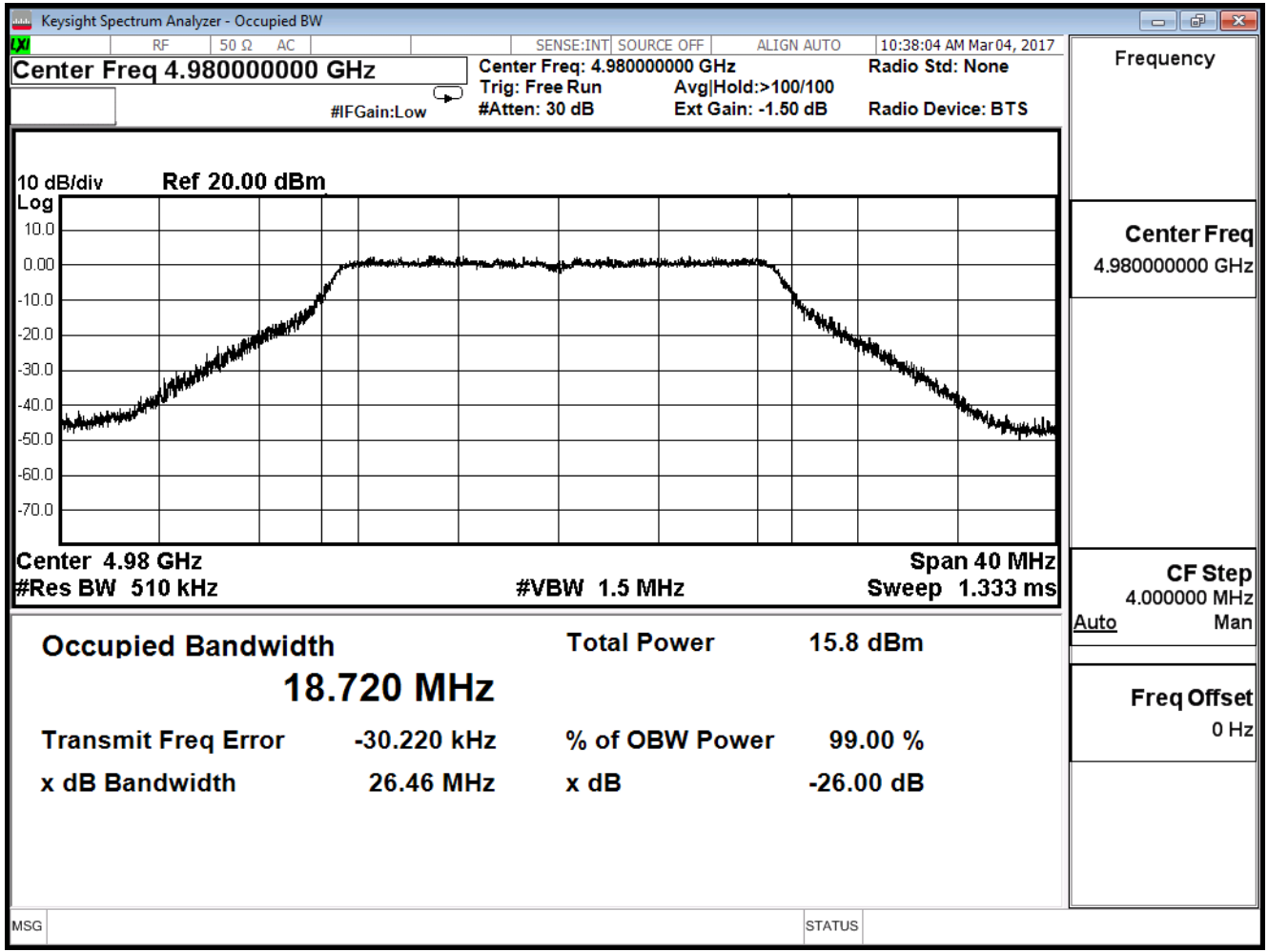

Channel 190 ANT1

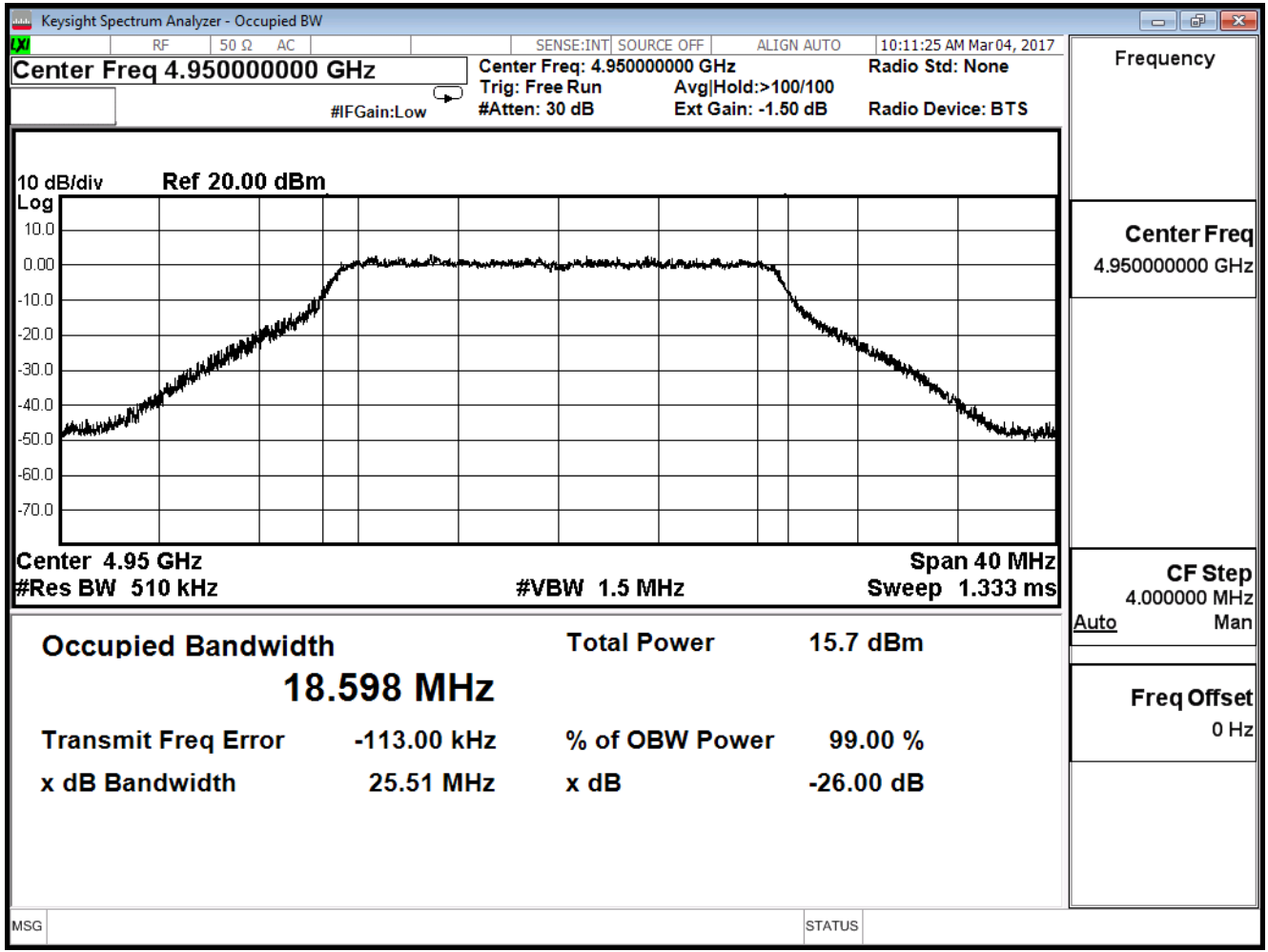

Channel 193 ANT1

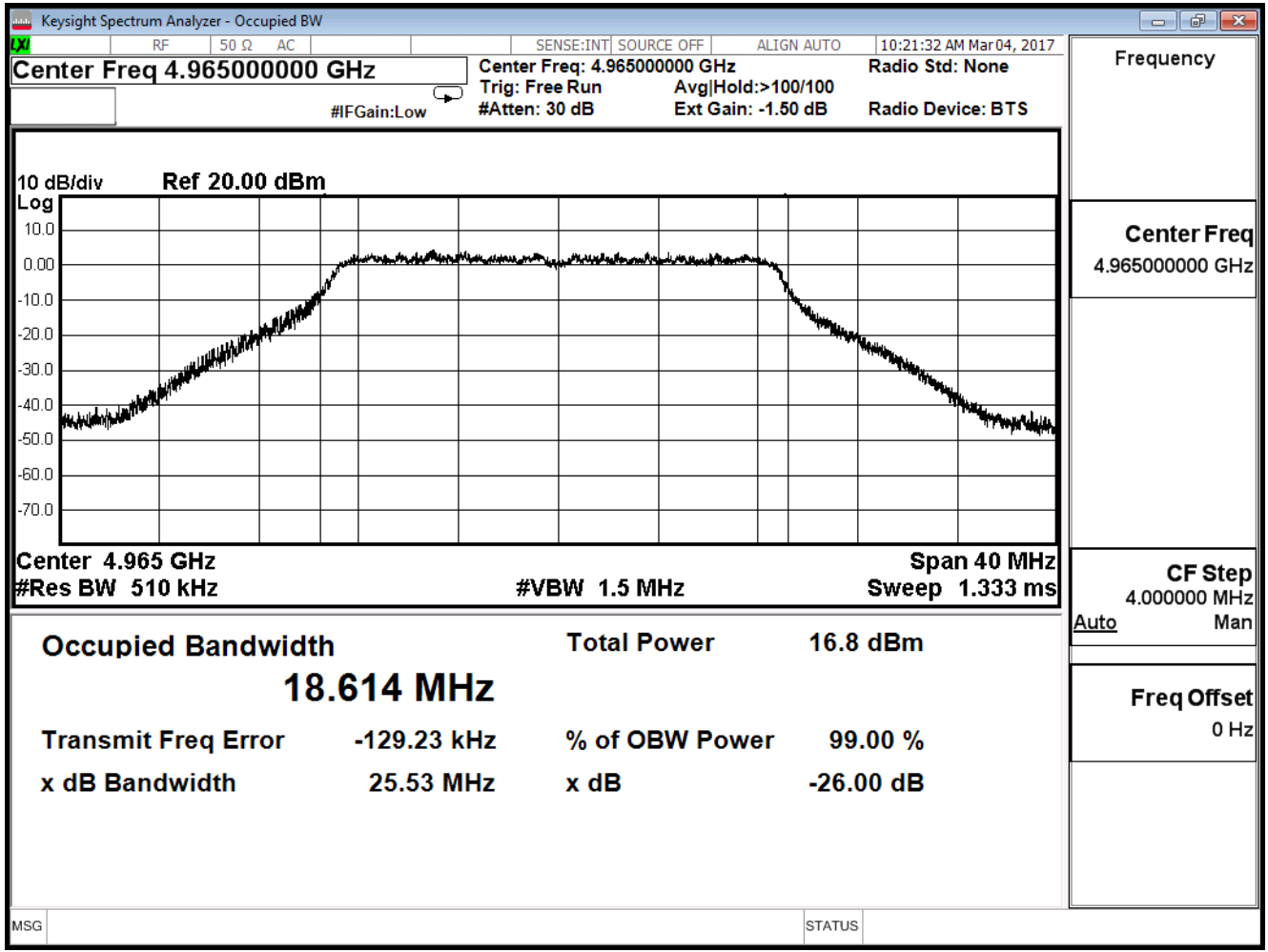

Channel 196 ANT1

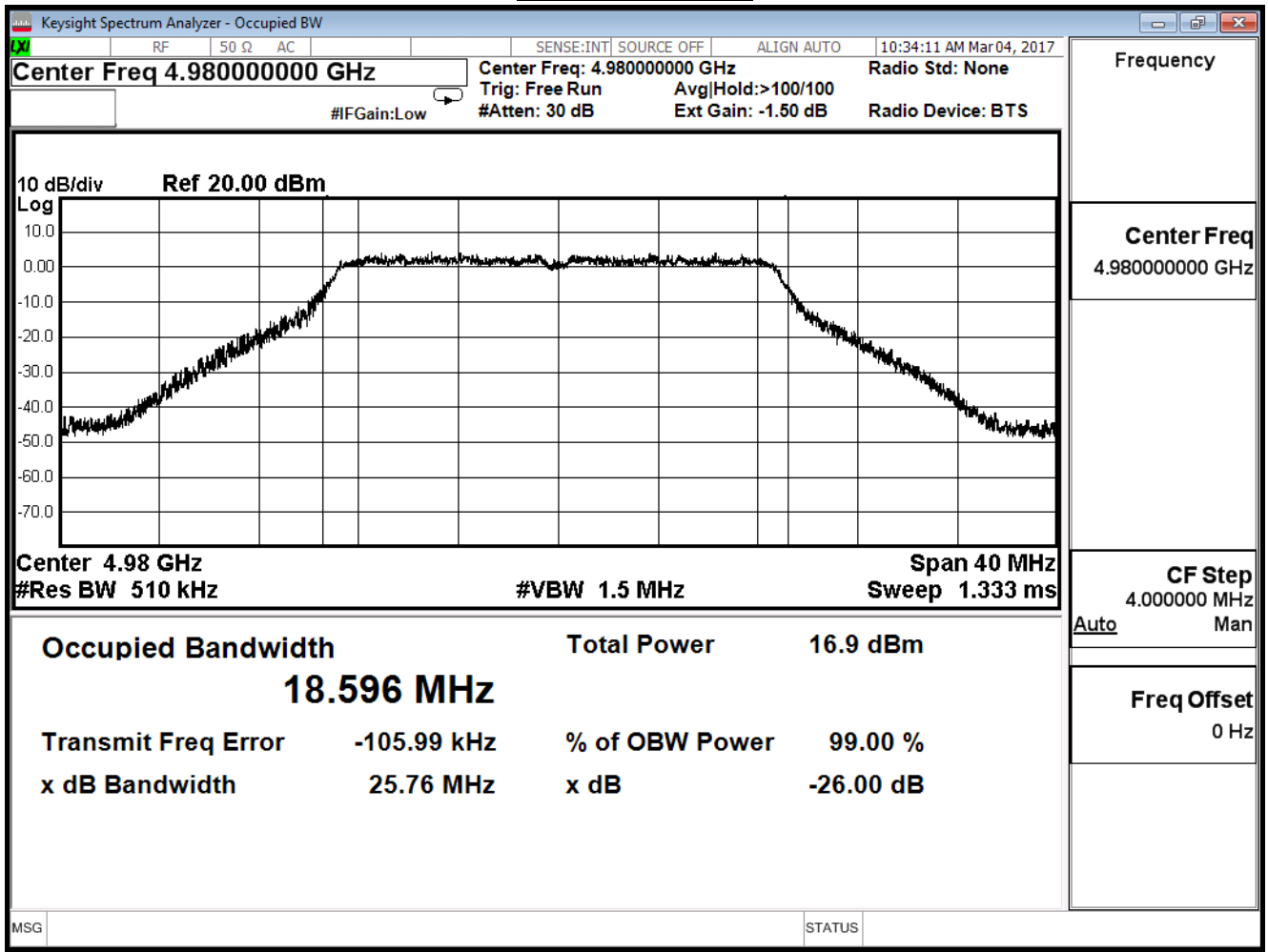

5. Power Spectral Density Mask

5.1. Test Equipment

The following test equipment's are used during the radiated emission tests:

Power Spectral Density Mask / SR10-H

Instrument	Manufacturer	Model No.	Serial No	Next Cal. Date
Spectrum Analyzer	Agilent	N9010A	US47140172	2017/08/08

Note: All equipment's that need to calibrate are with calibration period of 1 year.

5.2. Test Setup

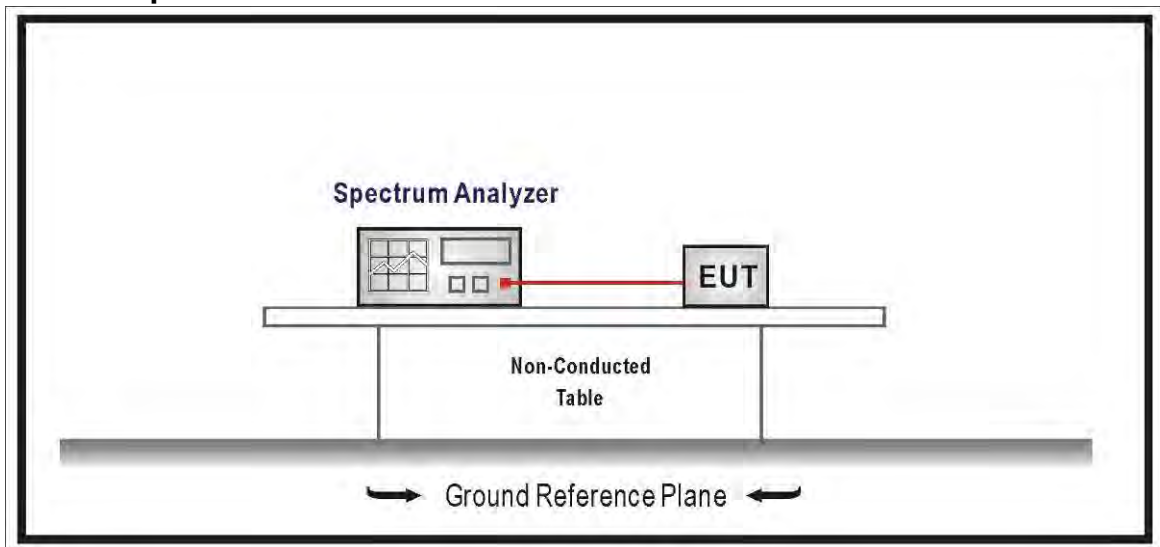

5.3. Limits

Emission Mask L. For low power transmitters (20 dBm or less) operating in the 4940–4990 MHz frequency band, the power spectral density of the emissions must be attenuated below the output power of the transmitter as follows:

- (1) On any frequency removed from the assigned frequency between 0–45% of the authorized bandwidth (BW): 0 dB.
- (2) On any frequency removed from the assigned frequency between 45–50% of the authorized bandwidth: $219 \log (\% \text{ of } (BW)/45)$ dB.
- (3) On any frequency removed from the assigned frequency between 50–55% of the authorized bandwidth: $10 + 242 \log (\% \text{ of } (BW)/50)$ dB.
- (4) On any frequency removed from the assigned frequency between 55–100% of the authorized bandwidth: $20 + 31 \log (\% \text{ of } (BW)/55)$ dB attenuation.
- (5) On any frequency removed from the assigned frequency between 100–150% of the authorized bandwidth: $28 + 68 \log (\% \text{ of } (BW)/100)$ dB attenuation.
- (6) On any frequency removed from the assigned frequency above 150% of the authorized bandwidth: 40 dB.

(7) The zero dB reference is measured relative to the highest average power of the fundamental emission measured across the designated channel bandwidth using a resolution bandwidth of at least one percent of the occupied bandwidth of the fundamental emission and a video bandwidth of 30 kHz. The power spectral density is the power measured within the resolution bandwidth of the measurement device divided by the resolution bandwidth of the measurement device. Emission levels are also based on the use of measurement instrumentation employing a resolution bandwidth of at least one percent of the occupied bandwidth.

Emission Mask M. For high power transmitters (greater than 20 dBm) operating in the 4940–4990 MHz frequency band, the power spectral density of the emissions must be attenuated below the output power of the transmitter as follows:

(1) On any frequency removed from the assigned frequency between 0–45% of the authorized bandwidth (BW): 0 dB.

(2) On any frequency removed from the assigned frequency between 45–50% of the authorized bandwidth: $568 \log (\% \text{ of } (BW)/45)$ dB.

(3) On any frequency removed from the assigned frequency between 50–55% of the authorized bandwidth: $26 + 145 \log (\% \text{ of } BW/50)$ dB.

(4) On any frequency removed from the assigned frequency between 55–100% of the authorized bandwidth: $32 + 31 \log (\% \text{ of } (BW)/55)$ dB.

(5) On any frequency removed from the assigned frequency between 100–150% of the authorized bandwidth: $40 + 57 \log (\% \text{ of } (BW)/100)$ dB.

(6) On any frequency removed from the assigned frequency between above 150% of the authorized bandwidth: 50 dB or $55 + 10 \log (P)$ dB, whichever is the lesser attenuation.

(7) The zero dB reference is measured relative to the highest average power of the fundamental emission measured across the designated channel bandwidth using a resolution bandwidth of at least one percent of the occupied bandwidth of the fundamental emission and a video bandwidth of 30 kHz. The power spectral density is the power measured within the resolution bandwidth of the measurement device divided by the resolution bandwidth of the measurement device. Emission levels are also based on the use of measurement instrumentation employing a resolution bandwidth of at least one percent of the occupied bandwidth.

Equipment Classification	
<input checked="" type="checkbox"/> Emission Mask L	<input type="checkbox"/> Emission Mask M

NOTE:

Emission Mask L. For low power transmitters (20 dBm or less)

Emission Mask M. For high power transmitters (greater than 20 dBm)

5.4. Test Procedure

TIA-603-C Section 2.2.11, 2.2.13 (with FCC deviations)

The EUT transmitter was connected to a spectrum analyzer through an appropriate 50 ohm attenuator. The reference level for the mask was set using the highest average power of the fundamental emission measured across the channel bandwidth using a RBW of at least 1% of the occupied bandwidth of the fundamental emission (91 kHz for this test) and a VBW of 30 kHz.

5.5. Uncertainty

±1.62dB

5.6. Test Result

Product	Mimosa C5c		
Test Item	Power Spectral Density Mask		
Test Mode	Mode 1: Transmit-Dish		
Date of Test	2017/04/13	Test Site	SR10-H

Channel 190 ANT0

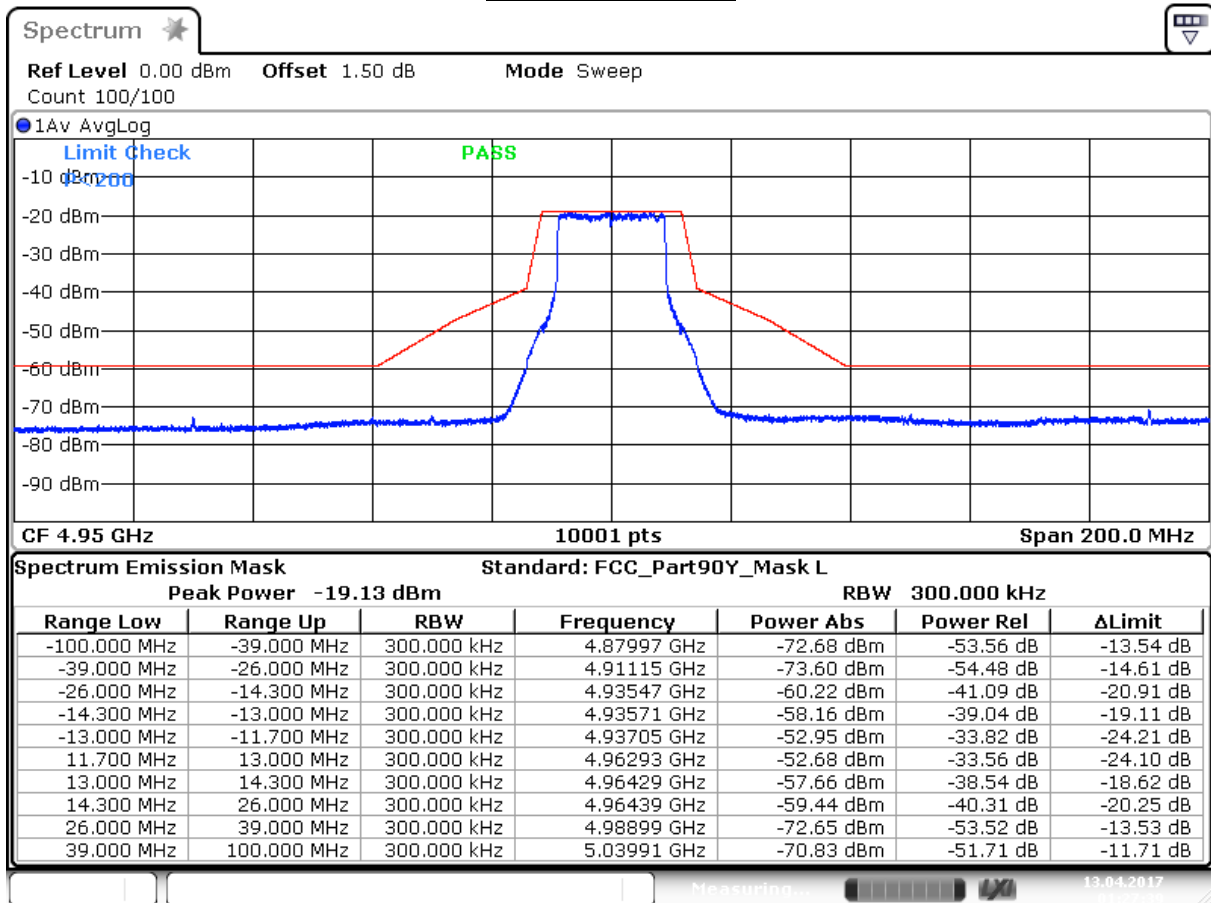

Date: 13 APR 2017 01:27:40

Channel 193 ANTO

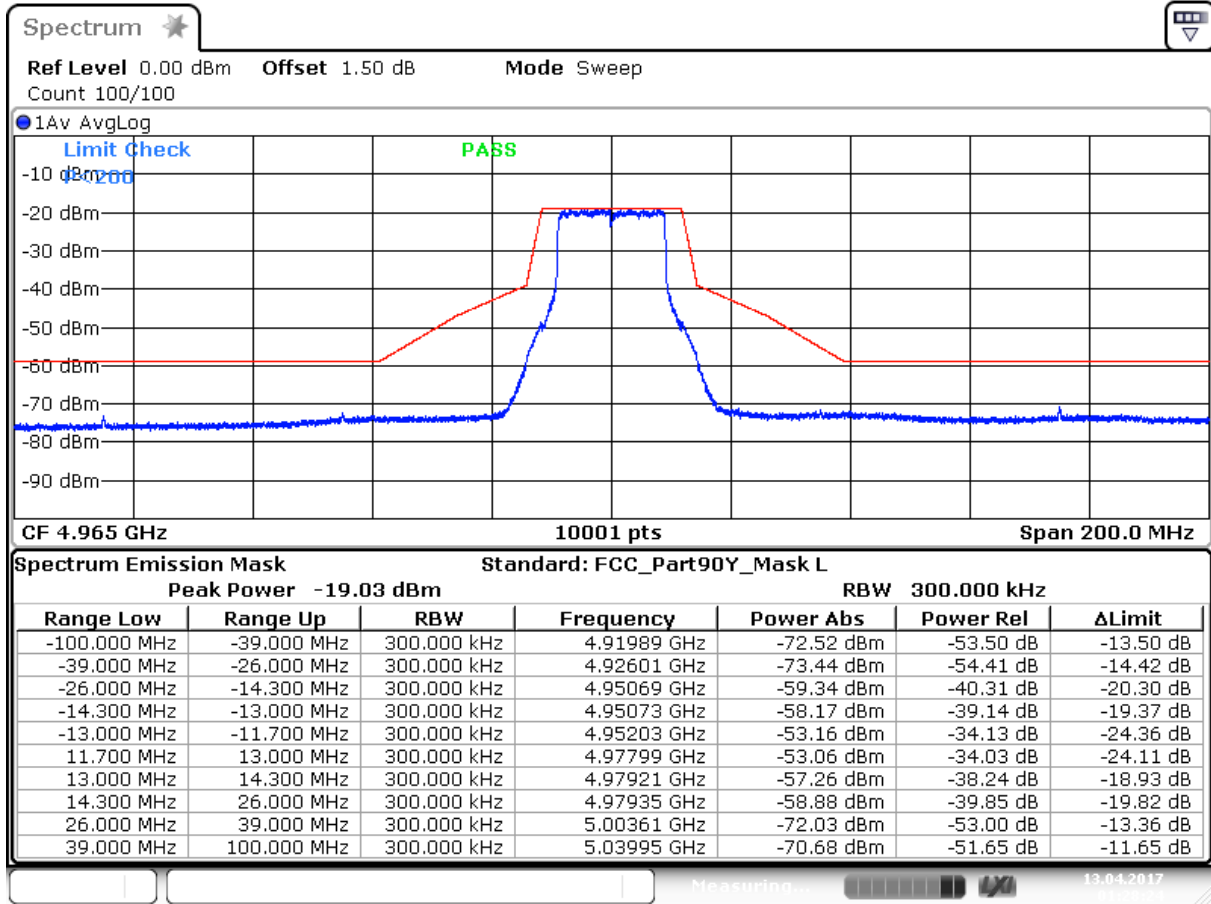

Date: 13 APR 2017 01:28:24

Channel 196 ANT0

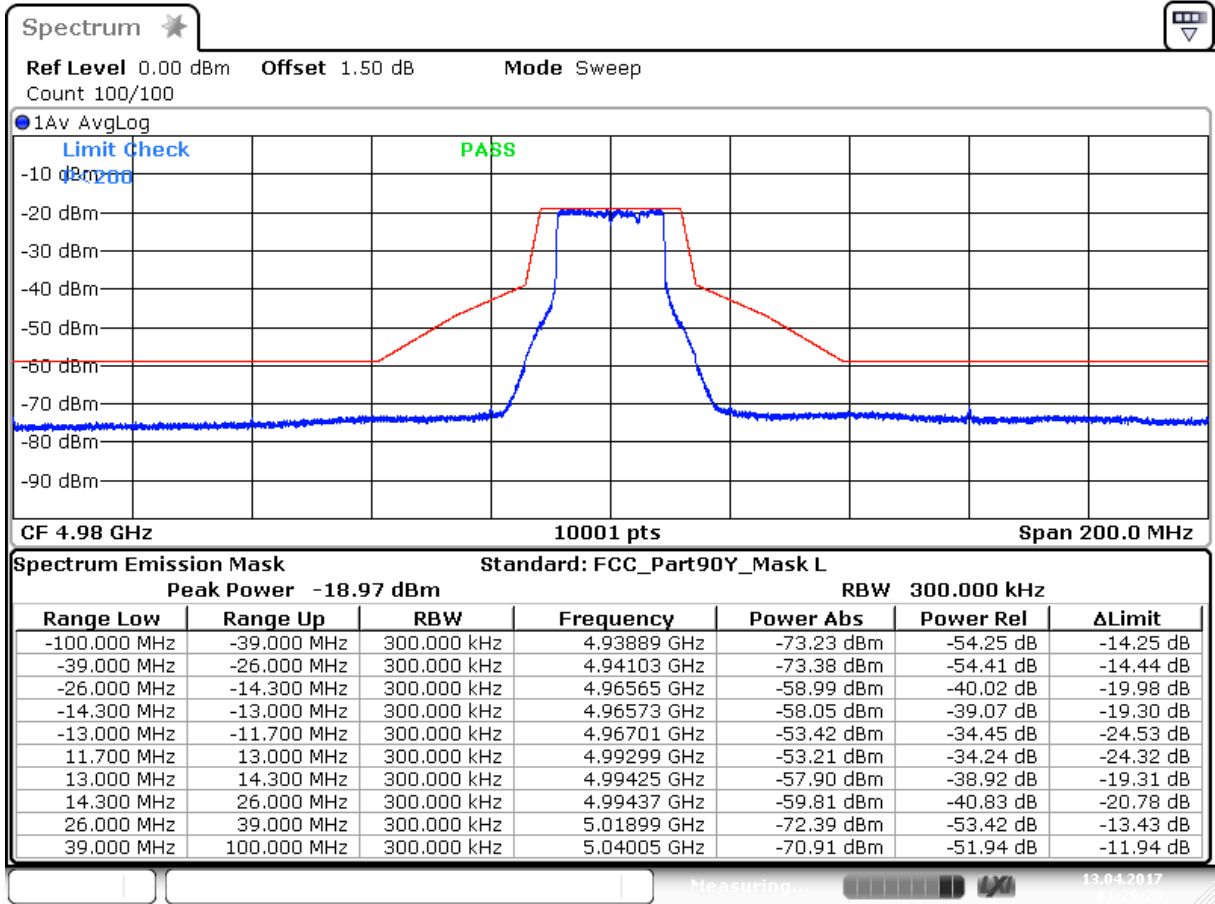

Date: 13 APR 2017 01:29:20

Channel 190 ANT1

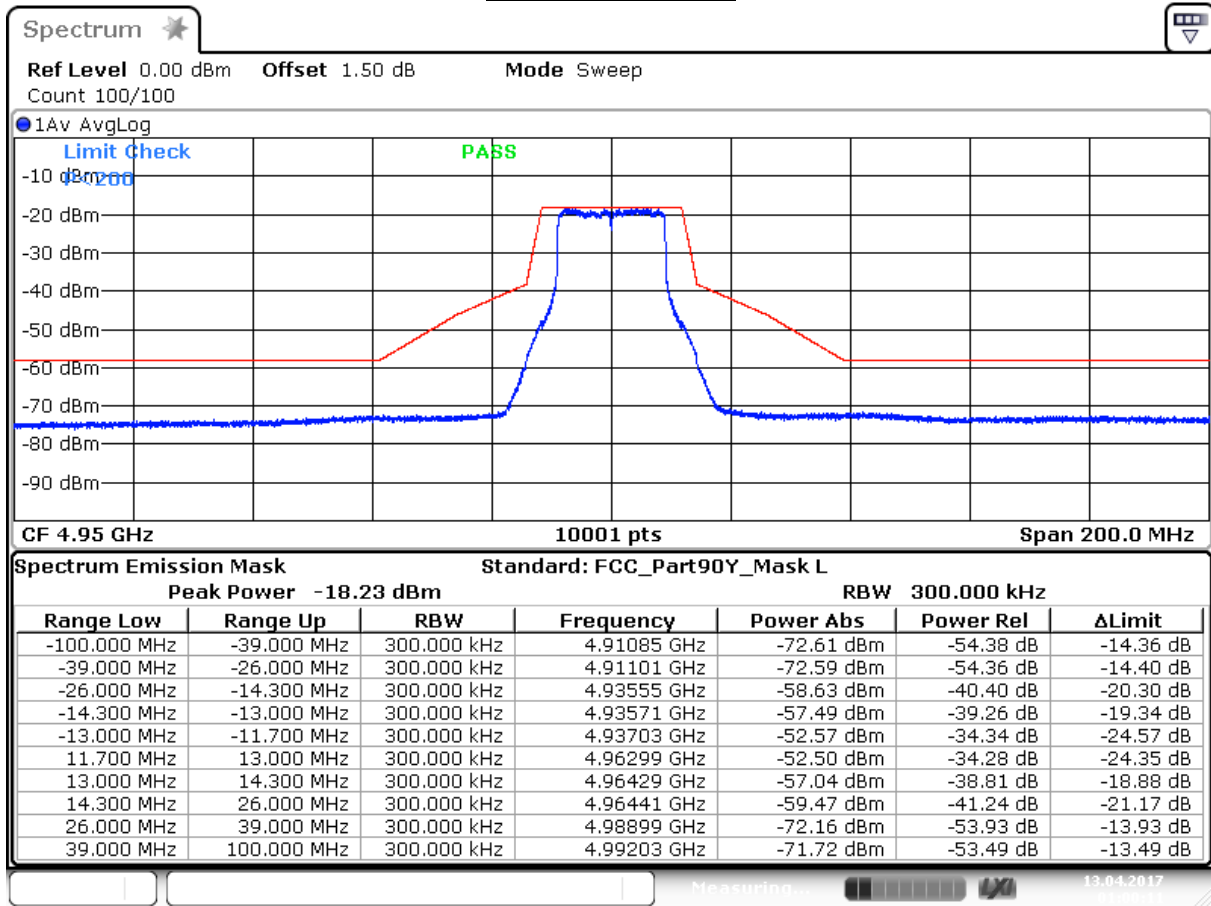

Date: 13 APR .2017 01:00:11

Channel 193 ANT1

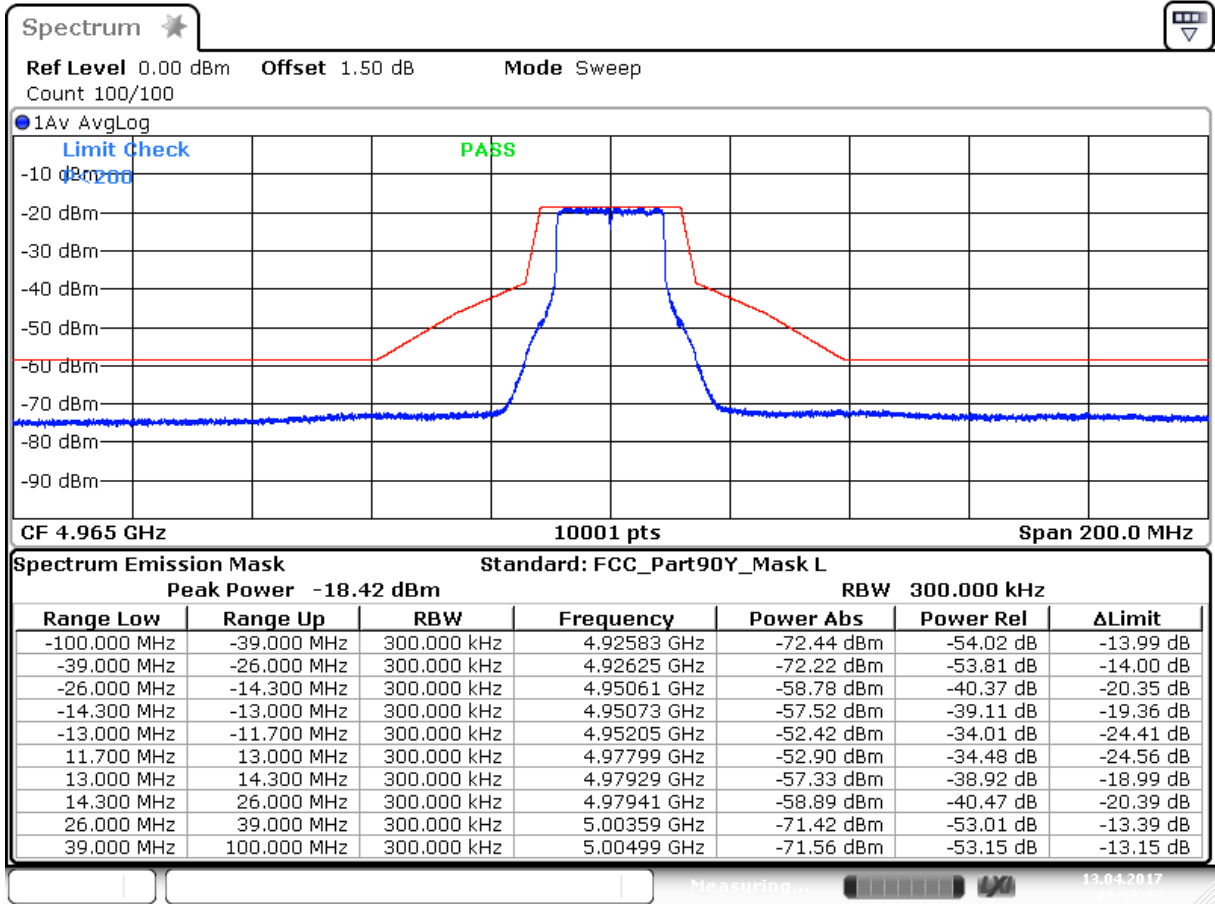

Date: 13 APR .2017 00:58:02

Channel 196 ANT1

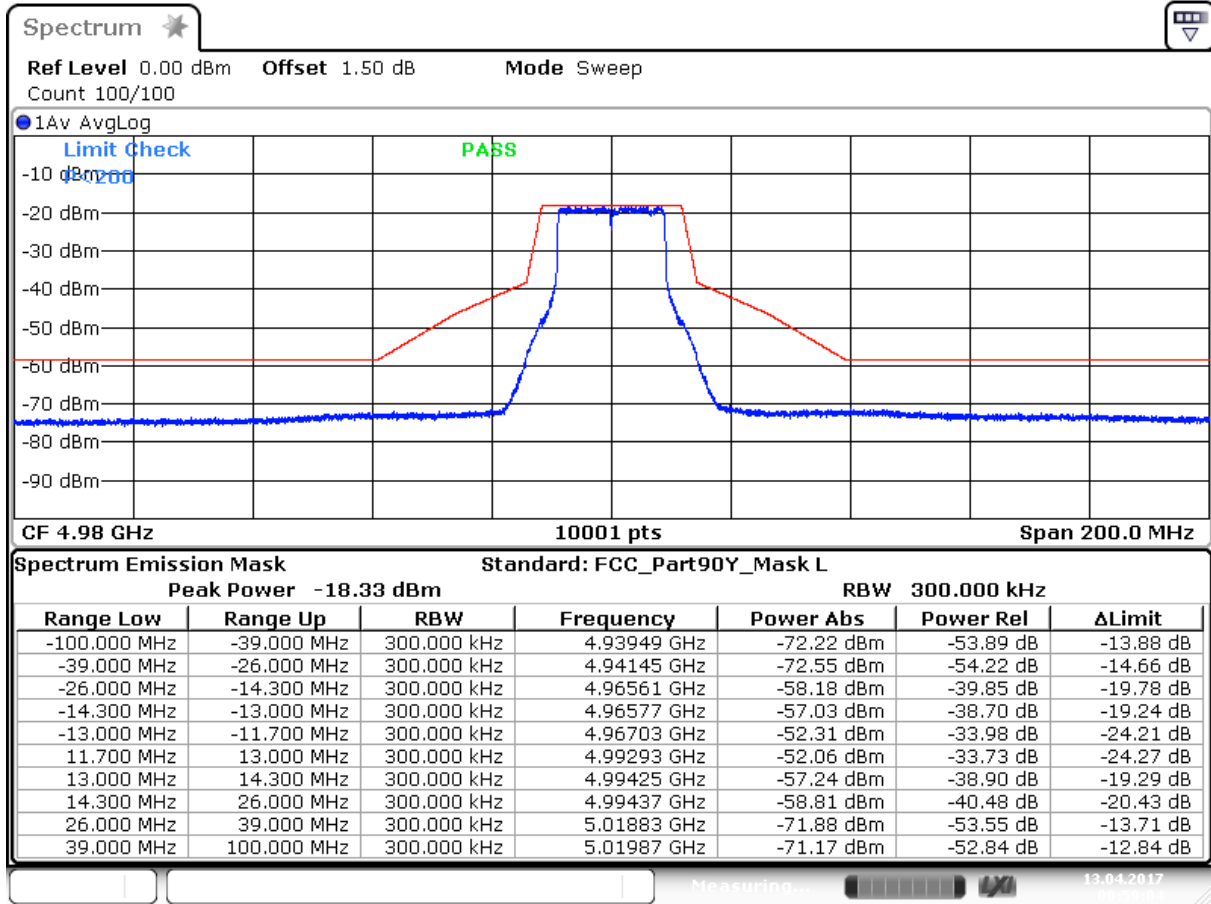

Date: 13 APR 2017 00:59:04

Product	Mimosa C5c		
Test Item	Power Spectral Density Mask		
Test Mode	Mode 2: Transmit-Dipole		
Date of Test	2017/03/06	Test Site	SR10-H

Channel 190 ANT0

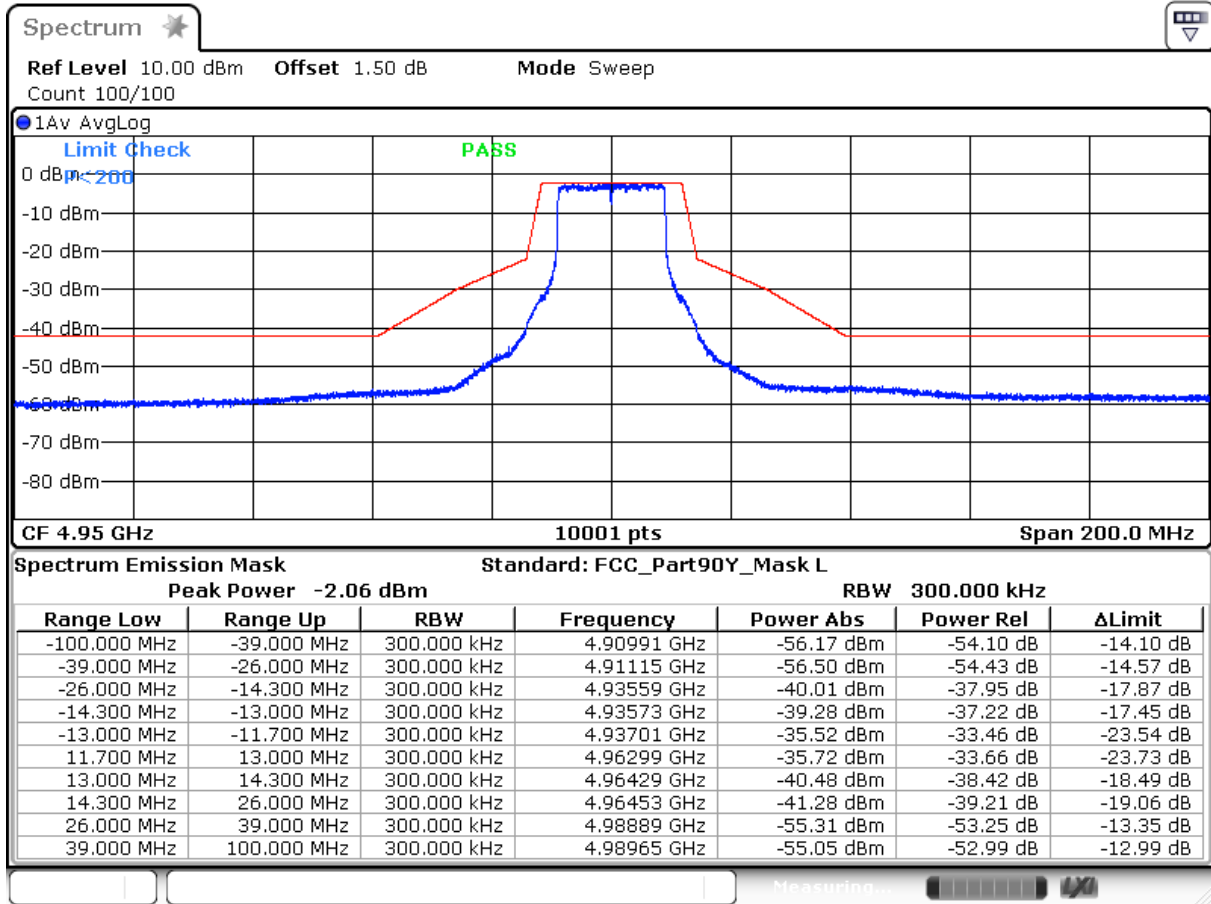

Date: 8 APR. 2017 02:34:47

Channel 193 ANTO

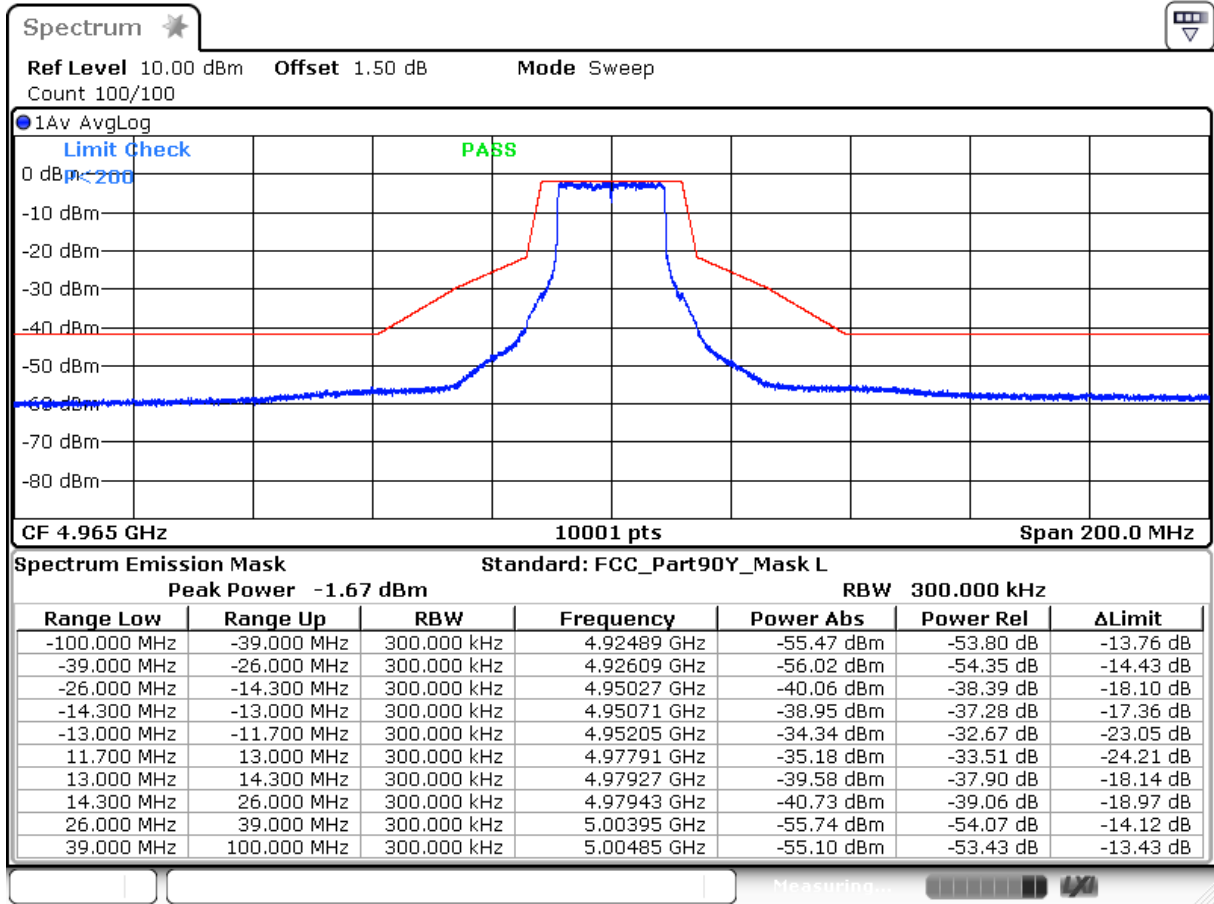

Date: 8 APR. 2017 02:34:05

Channel 196 ANTO

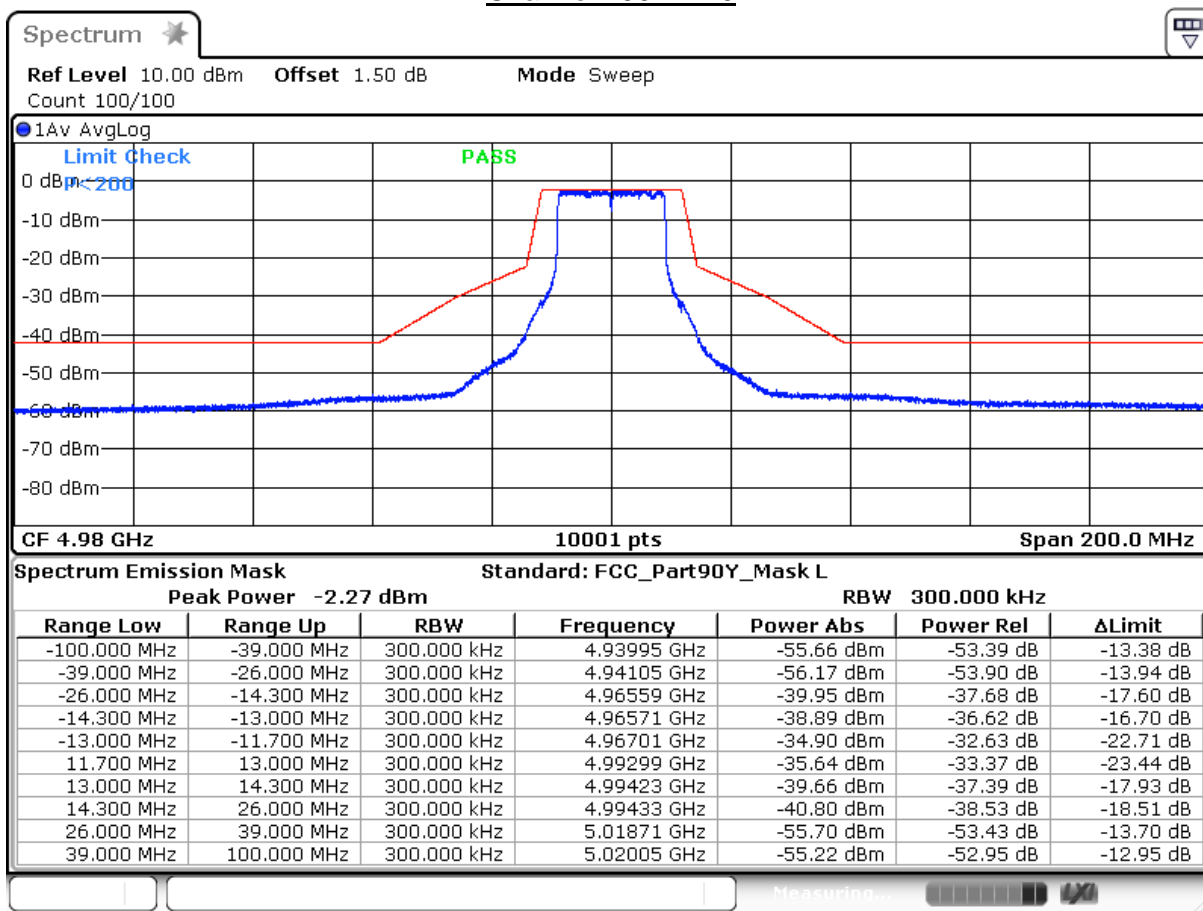

Date: 8 APR. 2017 02:33:30

Channel 190 ANT1

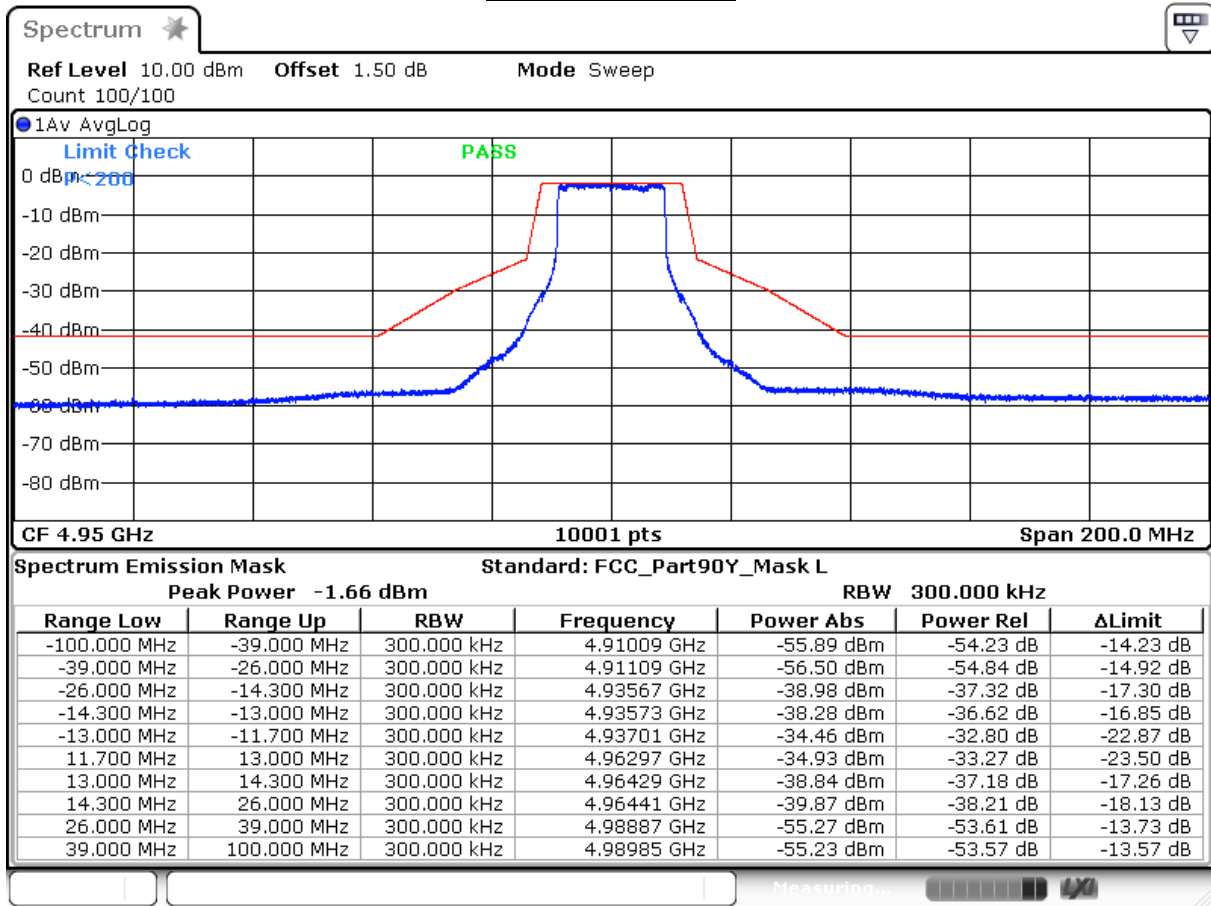

Date: 8 APR. 2017 02:29:05

Channel 193 ANT1

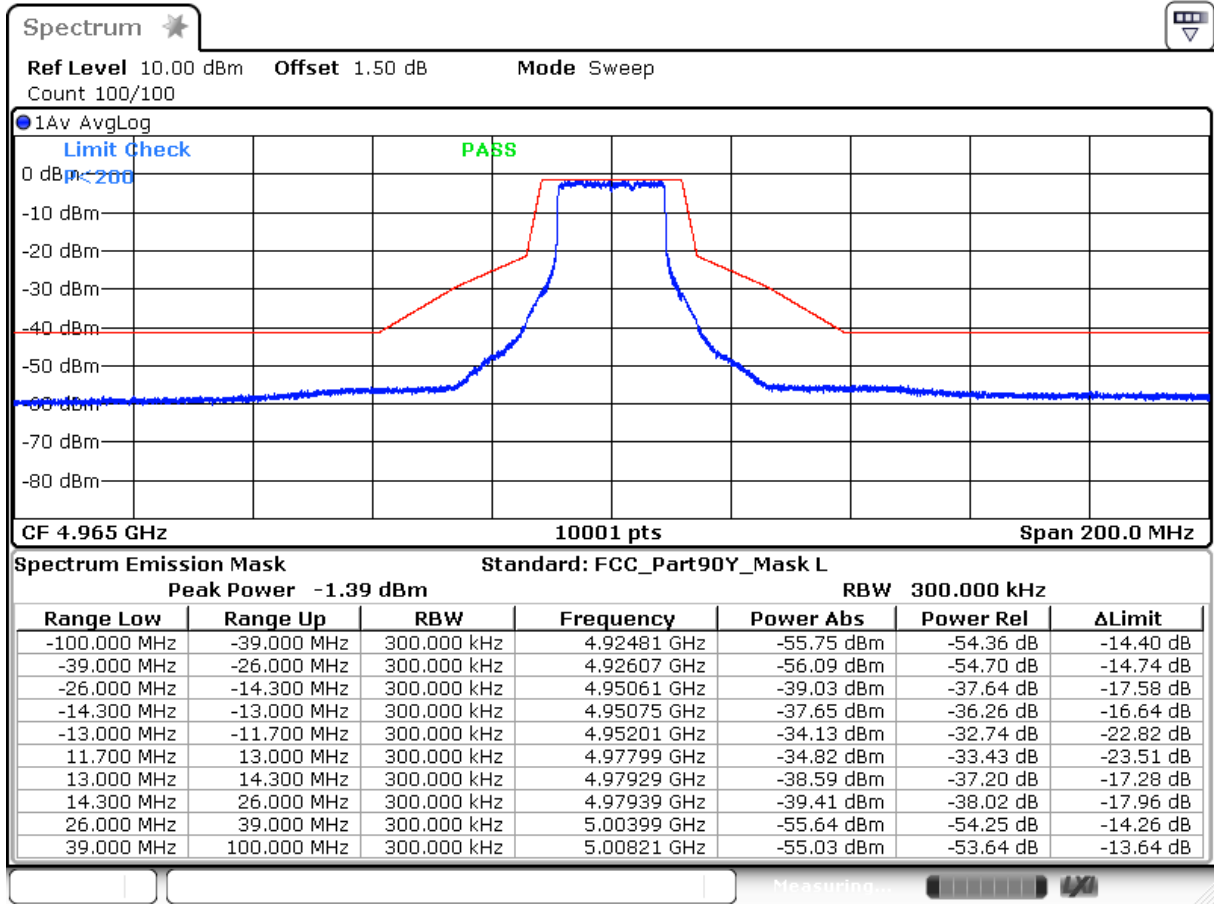

Date: 8 APR. 2017 02:31:48

Channel 196 ANT1

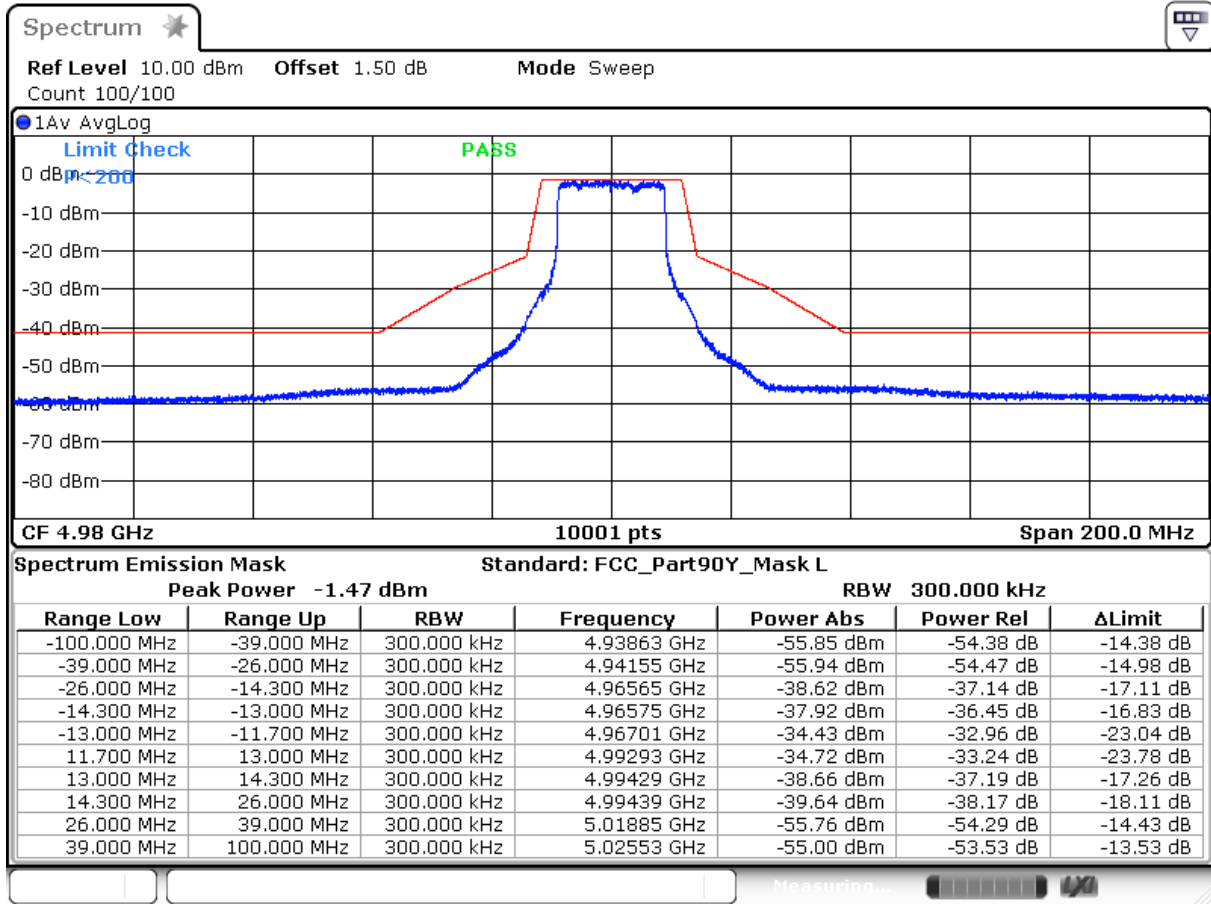

Date: 8 APR. 2017 02:32:30

Result	Pass
--------	------

6. Peak Excursion

6.1. Test Equipment

The following test equipment's are used during the radiated emission tests:

Peak Excursion / SR10-H

Instrument	Manufacturer	Model No.	Serial No	Next Cal. Date
Spectrum Analyzer	Agilent	N9010A	US47140172	2017/08/08

Note: All equipment's that need to calibrate are with calibration period of 1 year.

6.2. Test Setup

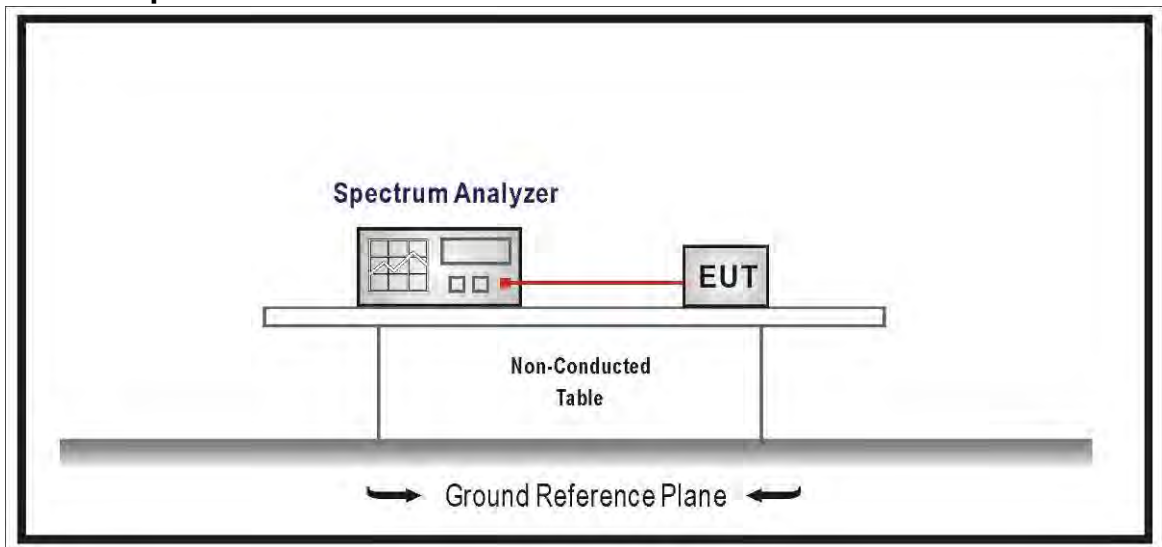

6.3. Limits

The ratio of the peak excursion of the modulation envelope (measured using a peak hold function) to the peak transmit power (measured as specified above) shall not exceed 13 dB across any 1 MHz bandwidth or the emission bandwidth whichever is less.

6.4. Test Procedure

- 1) Compliance with the peak excursion requirement of Section 90.1215 shall be demonstrated by confirming that the ratio of the maximum of the peak-max-hold spectrum to the maximum of the average spectrum for continuous transmission does not exceed 13 dB. (Earlier procedures that required computing the ratio of the two spectra at each frequency across the emission bandwidth can lead to unintended failures at band edges and will no longer be required.)
- 2) Set the spectrum analyzer span to view the entire emission bandwidth.
- 3) Find the maximum of the peak-max-hold spectrum.
 - a) Set RBW = 1 MHz.
 - b) VBW \geq 3 MHz.
 - c) Detector = peak.
 - d) Trace mode = max-hold.
 - e) Allow the sweeps to continue until the trace stabilizes.
 - f) Use the peak search function to find the peak of the spectrum.
- 4) Use the procedure found under E) to measure the PPSD.
- 5) Compute the ratio of the maximum of the peak-max-hold spectrum to the PPSD.

6.5. Uncertainty

± 1.62 dB

6.6. Test Result

Product	Mimosa C5c		
Test Item	Peak Excursion		
Test Mode	Mode 1: Transmit-Dish		
Date of Test	2017/04/13	Test Site	SR10-H

Channel	Frequency (MHz)	ANT0 (dBc)	ANT1 (dBc)	Limit (dBc)
190	4950	-8.595	-8.972	<13
193	4965	-8.587	-8.887	
196	4980	-8.535	-9.027	

Channel 190 ANT0

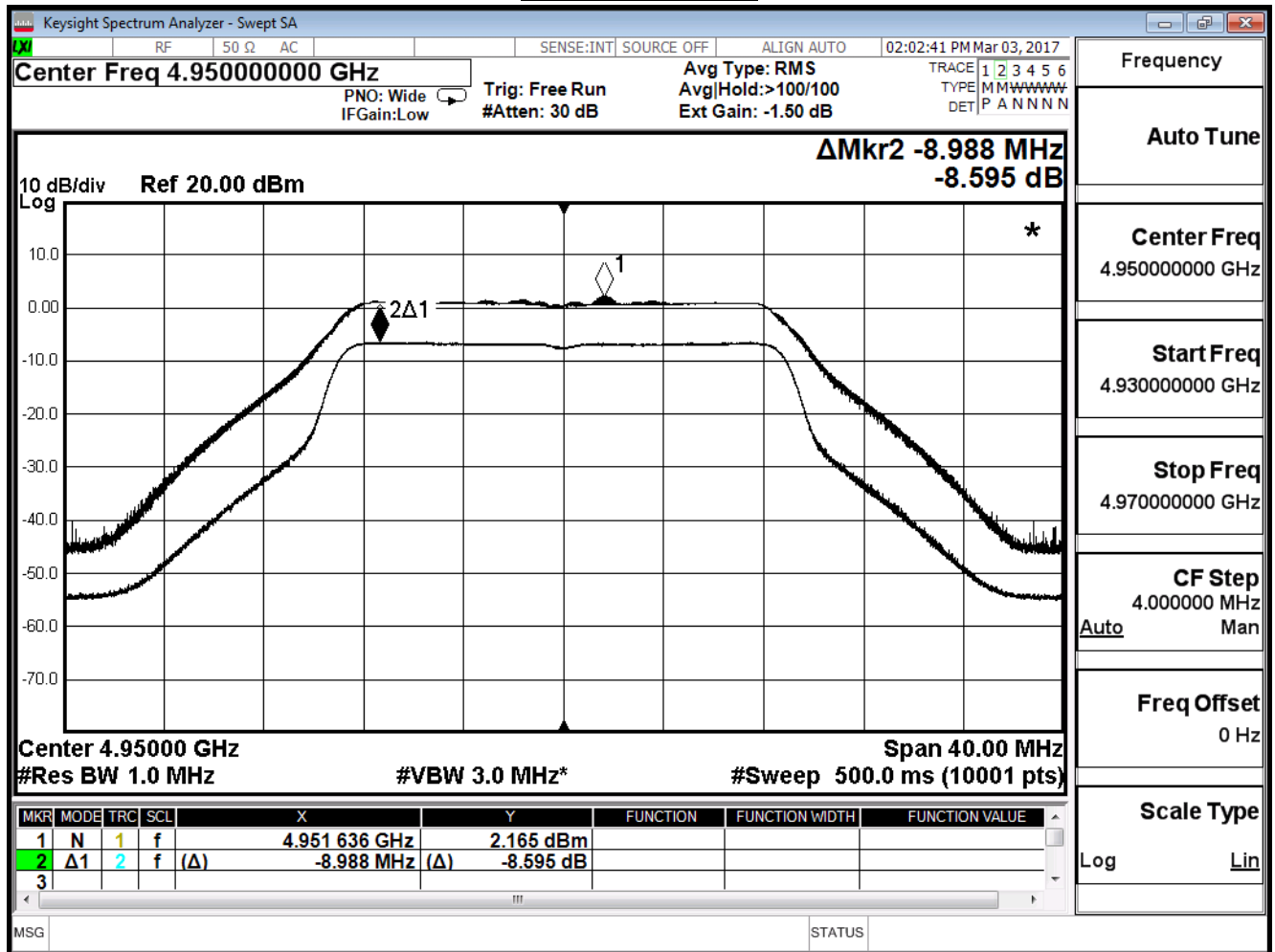

Channel 193 ANT0

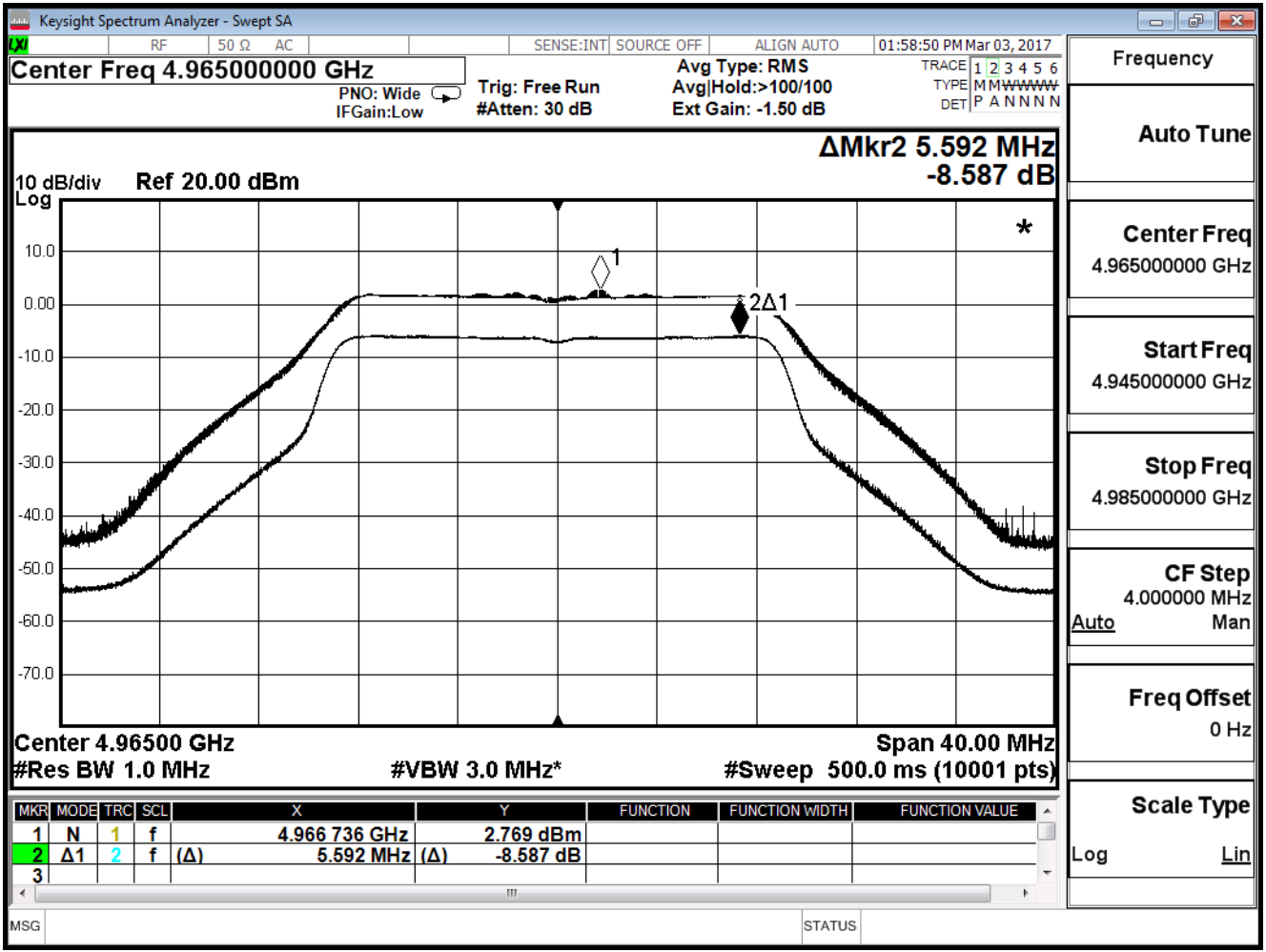

Channel 196 ANT0

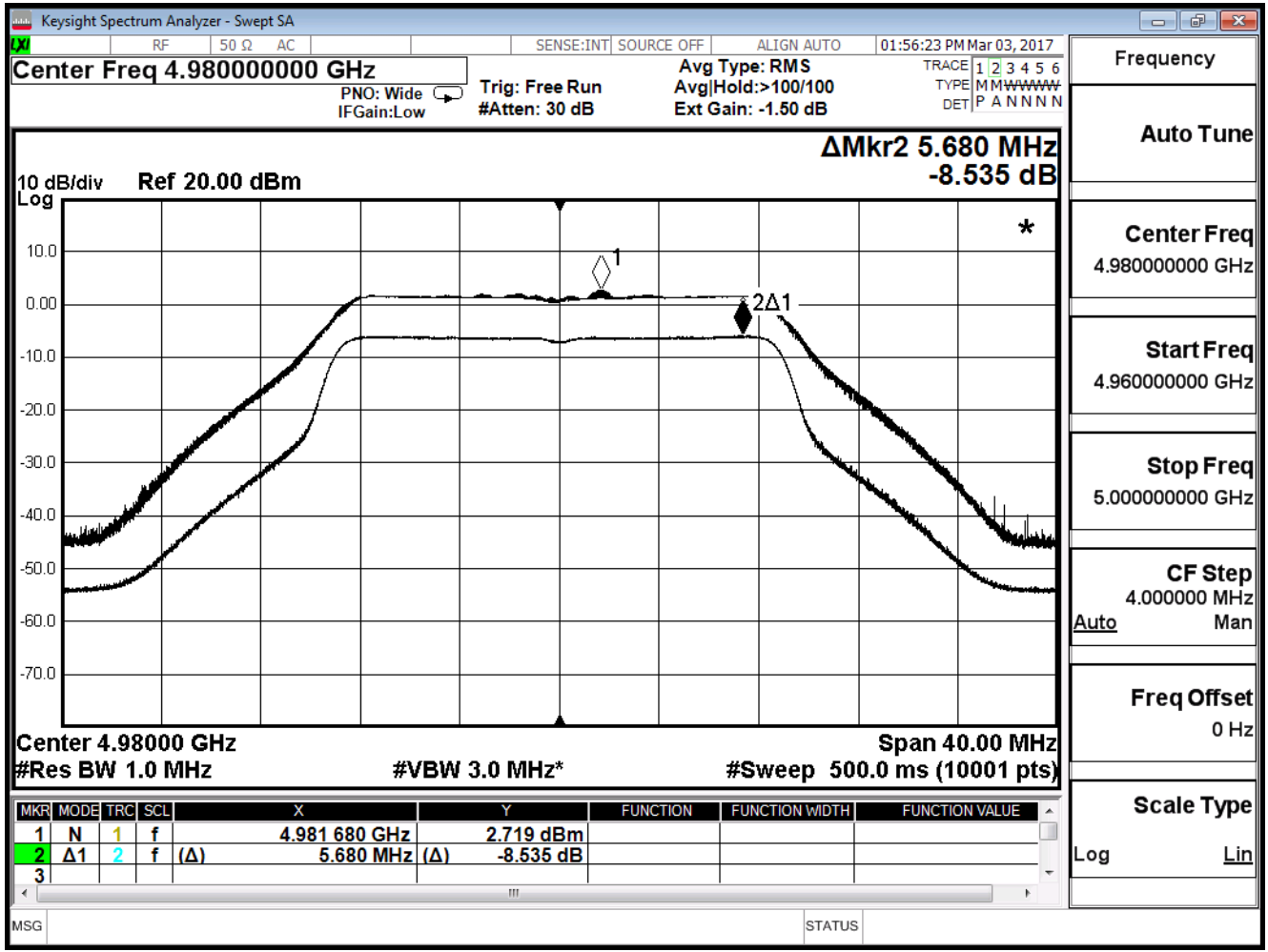

Channel 190 ANT1

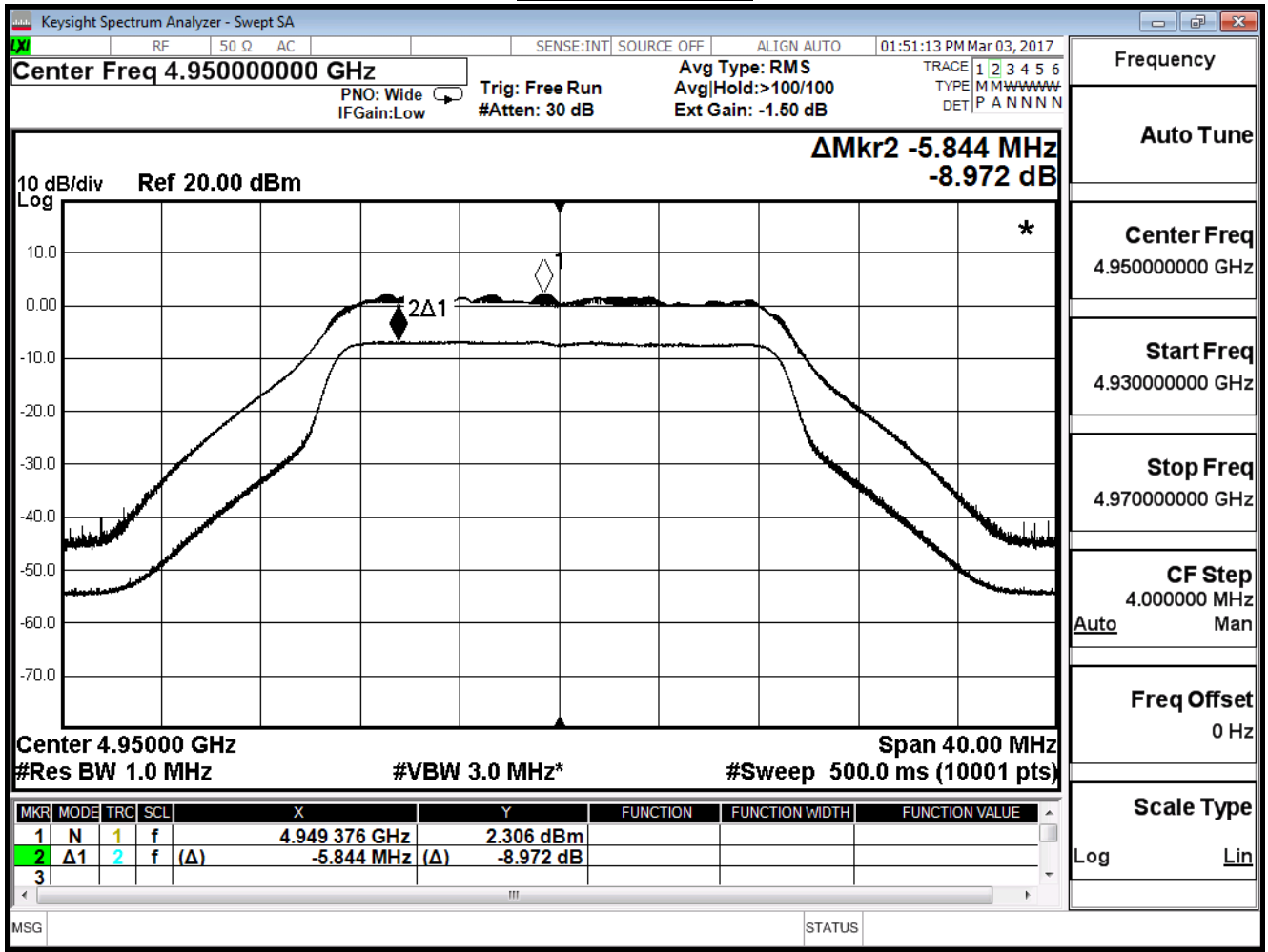

Frequency	
Auto Tune	
Center Freq	4.950000000 GHz
Start Freq	4.930000000 GHz
Stop Freq	4.970000000 GHz
CF Step	4.000000 MHz
Auto Man	
Freq Offset	0 Hz
Scale Type	Log Lin

Channel 193 ANT1

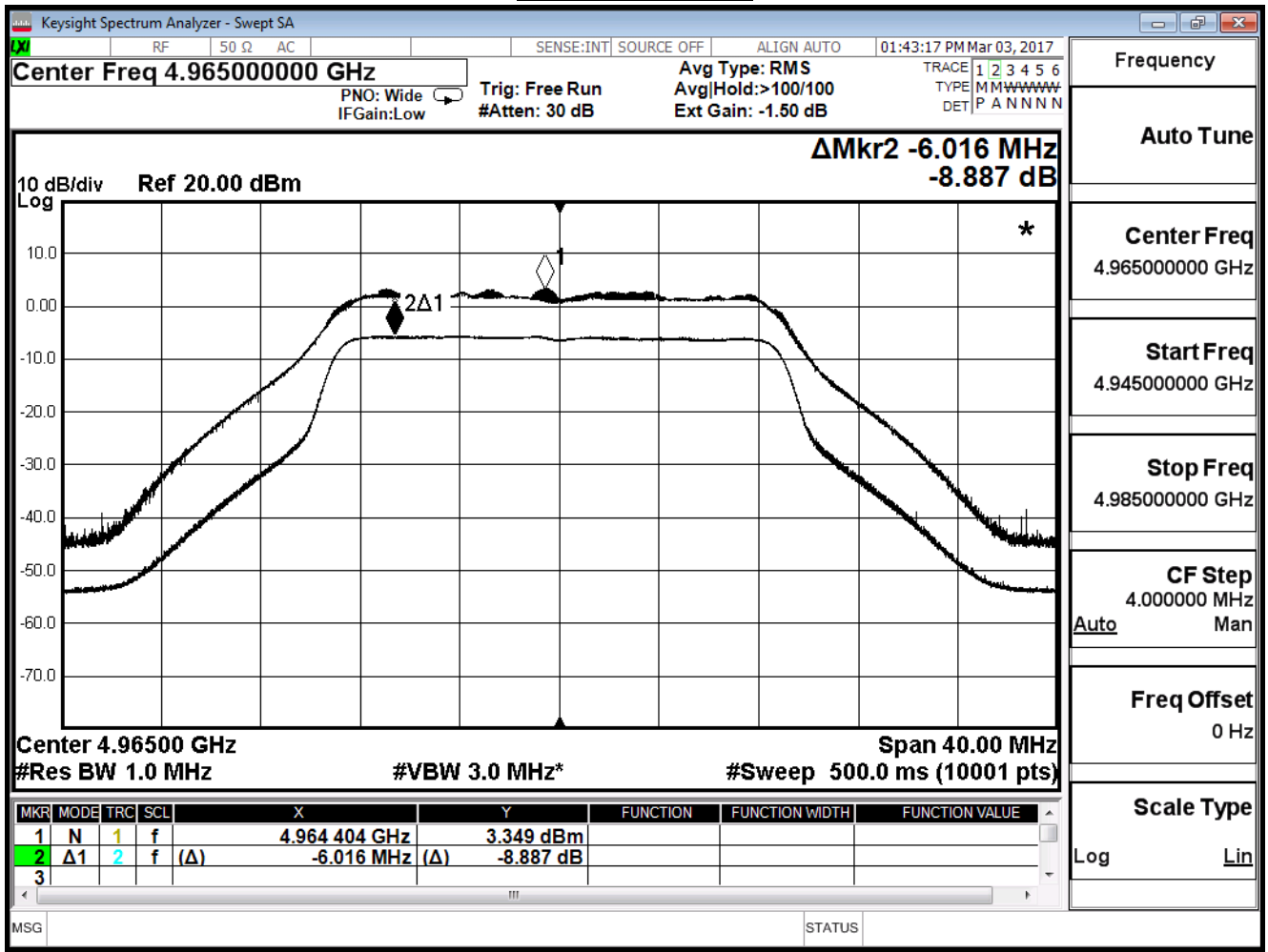

Channel 196 ANT1

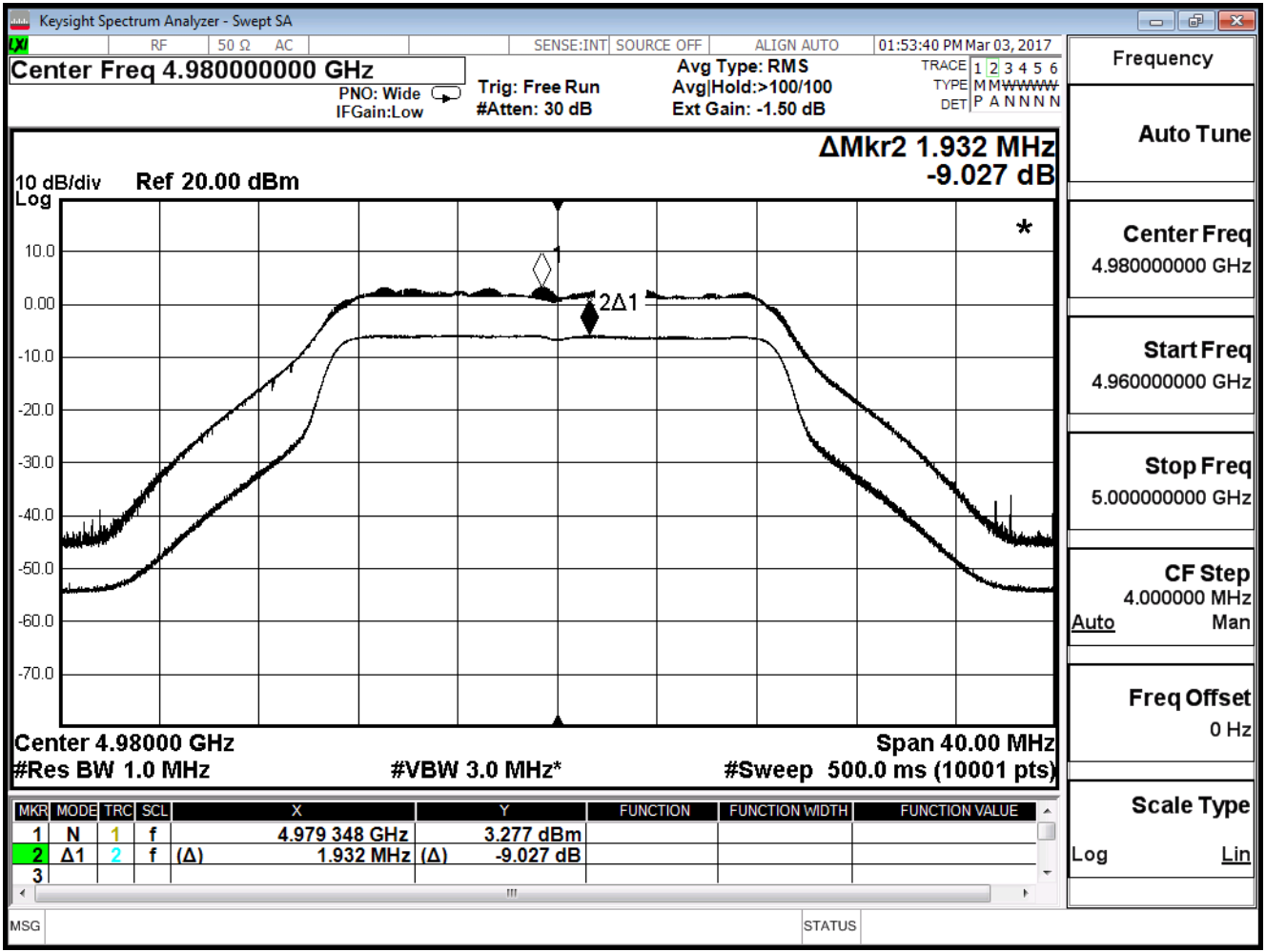

Product	Mimosa C5c		
Test Item	Peak Excursion		
Test Mode	Mode 2: Transmit-Dipole		
Date of Test	2017/03/03	Test Site	SR10-H

Channel	Frequency (MHz)	ANT0 (dBc)	ANT1 (dBc)	Limit (dBc)
190	4950	-8.481	-8.887	<13
193	4965	-8.376	-8.992	
196	4980	-8.536	-9.070	

Channel 190 ANT0

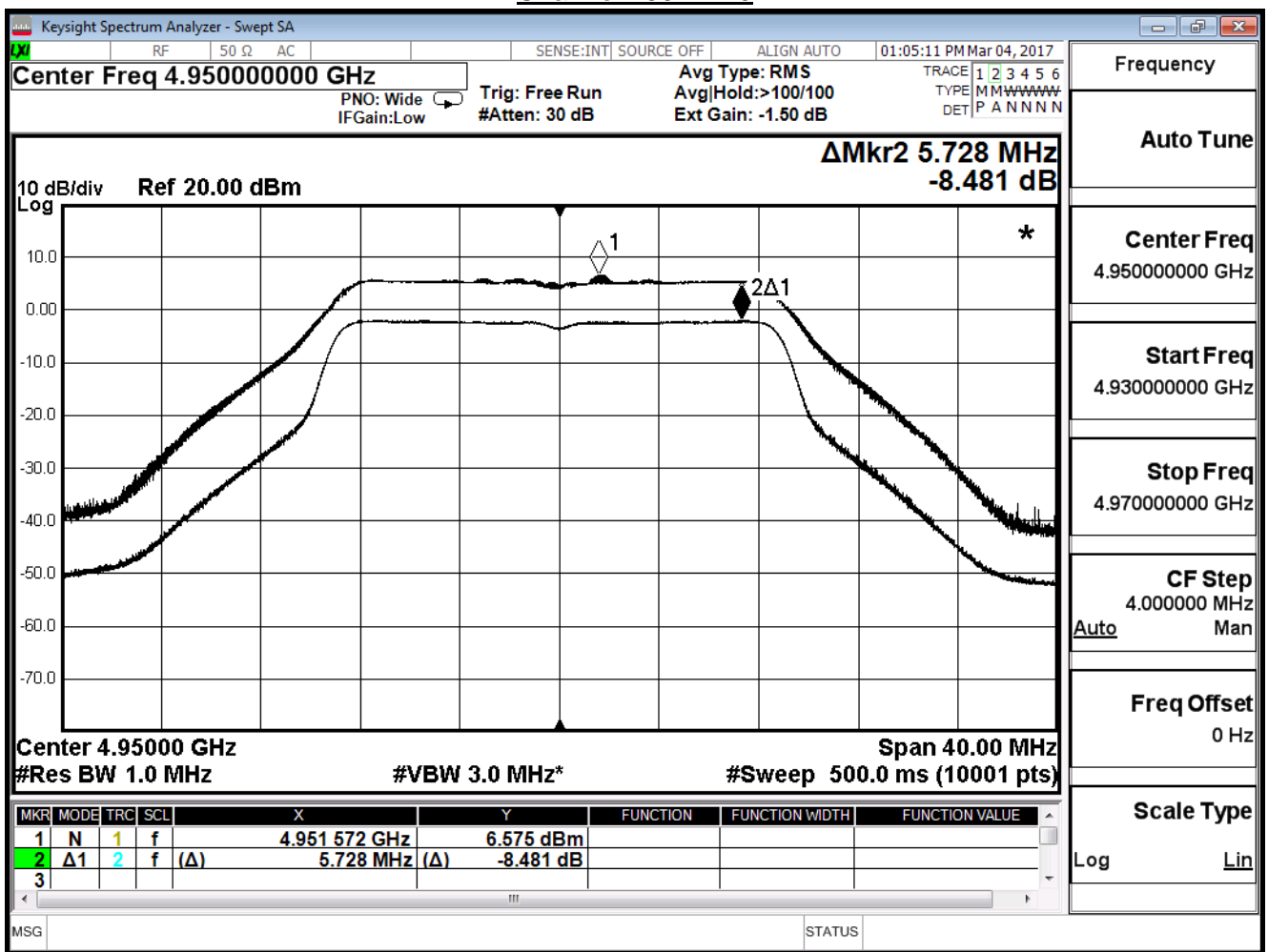

Channel 193 ANT0

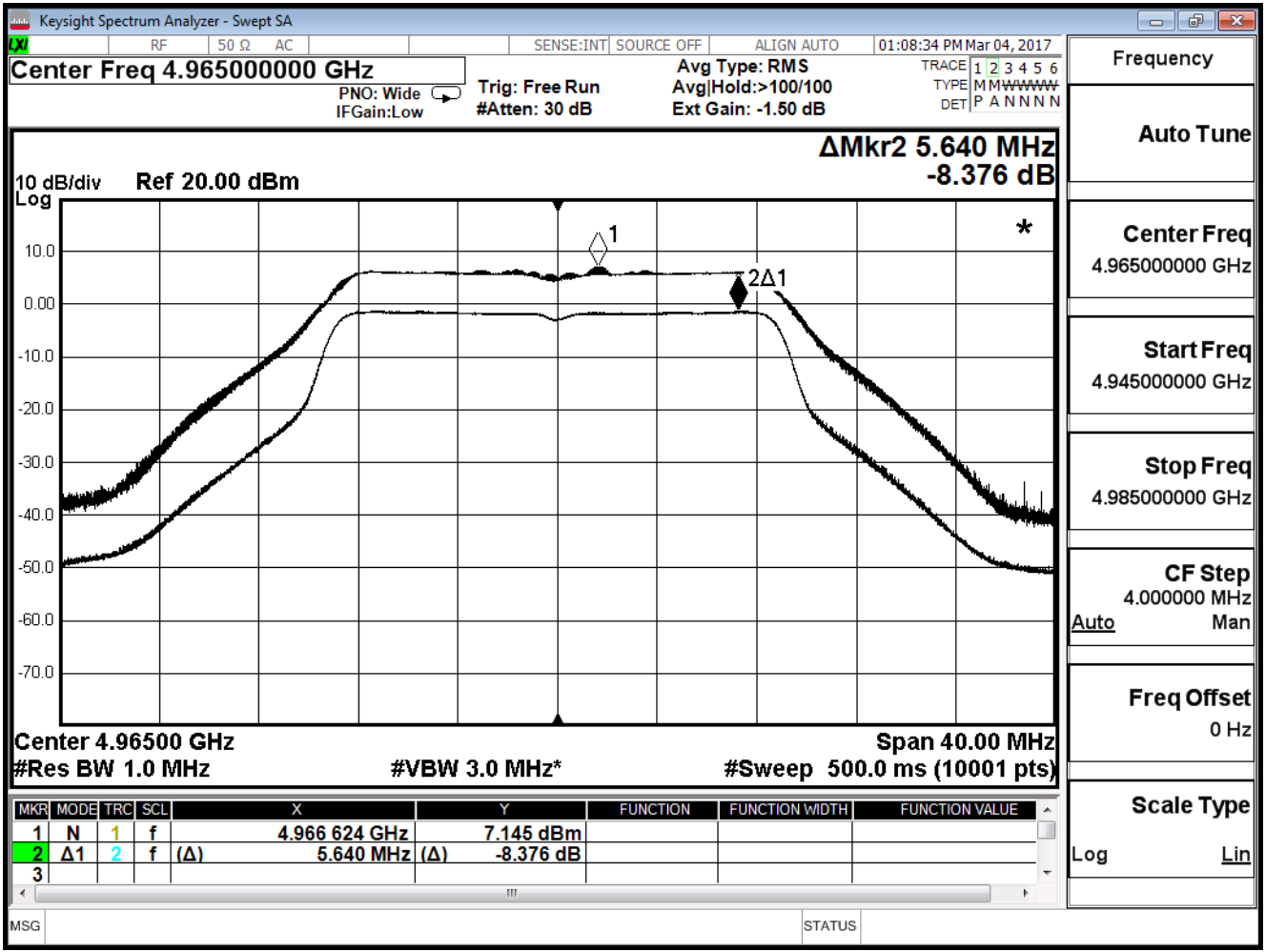

Frequency	
Auto Tune	
Center Freq	4.965000000 GHz
Start Freq	4.945000000 GHz
Stop Freq	4.985000000 GHz
CF Step	4.000000 MHz
Auto	Man
Freq Offset	0 Hz
Scale Type	Log Lin

Channel 196 ANT0

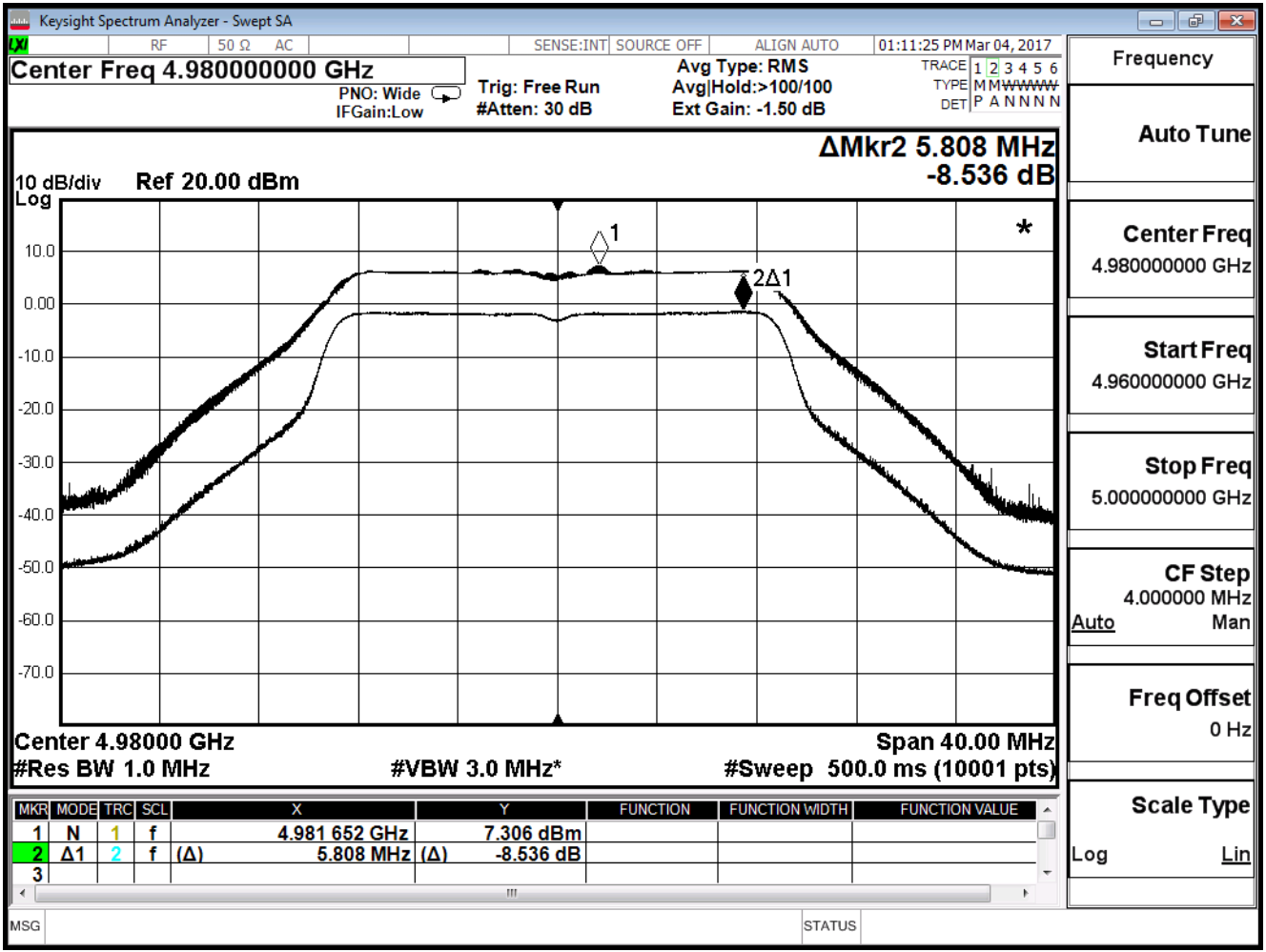

Channel 190 ANT1

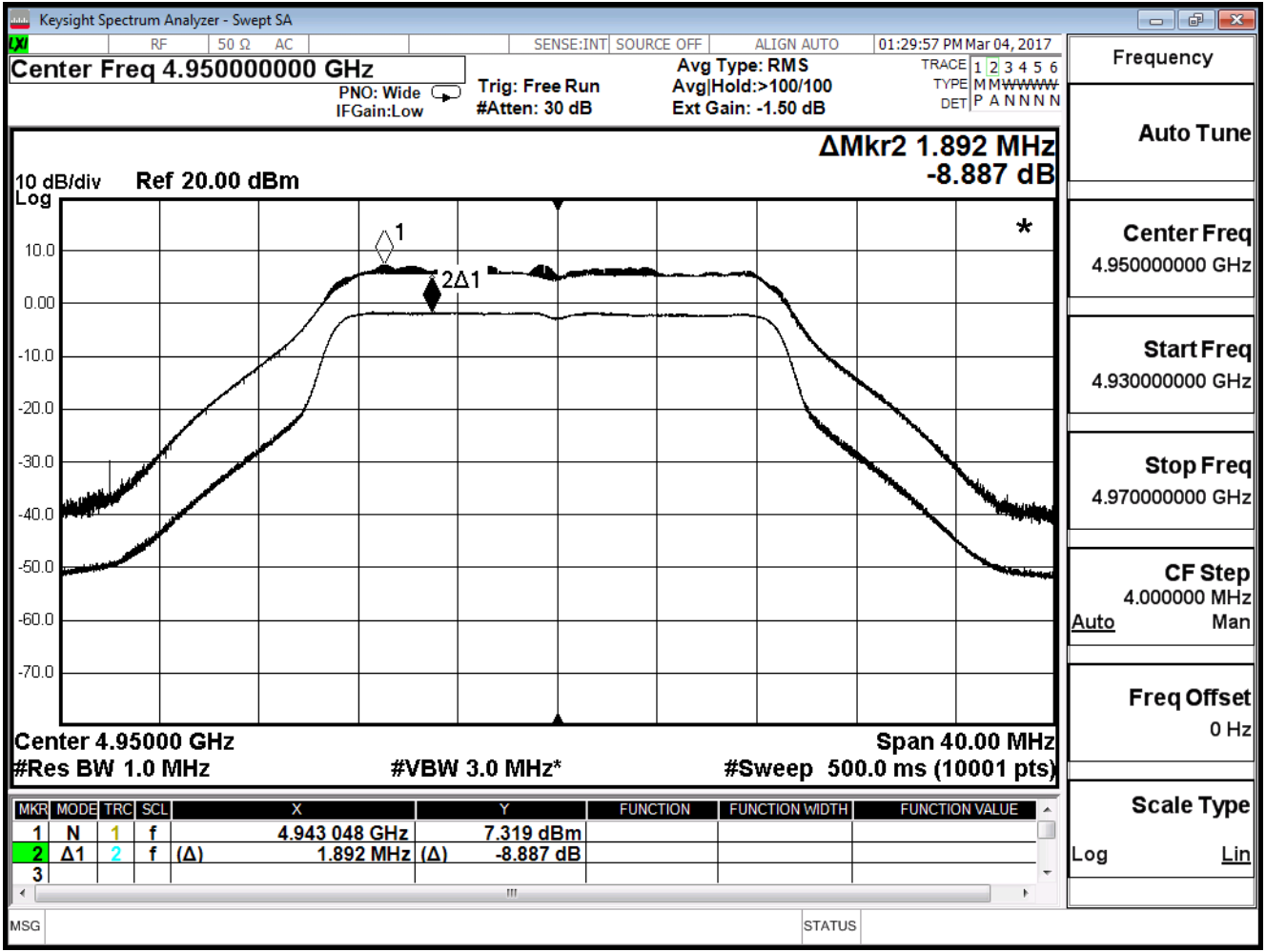

Channel 193 ANT1

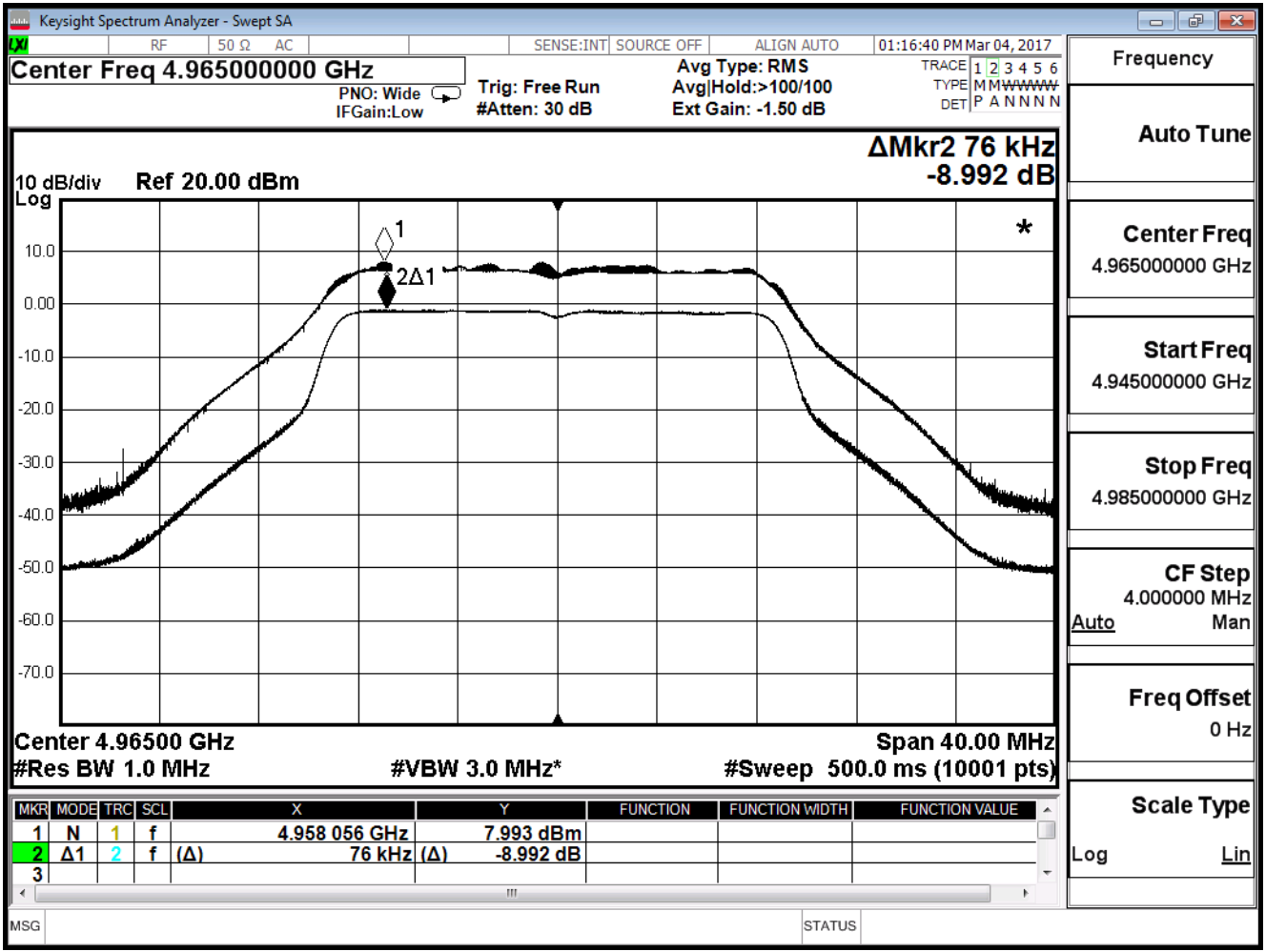

Channel 196 ANT1

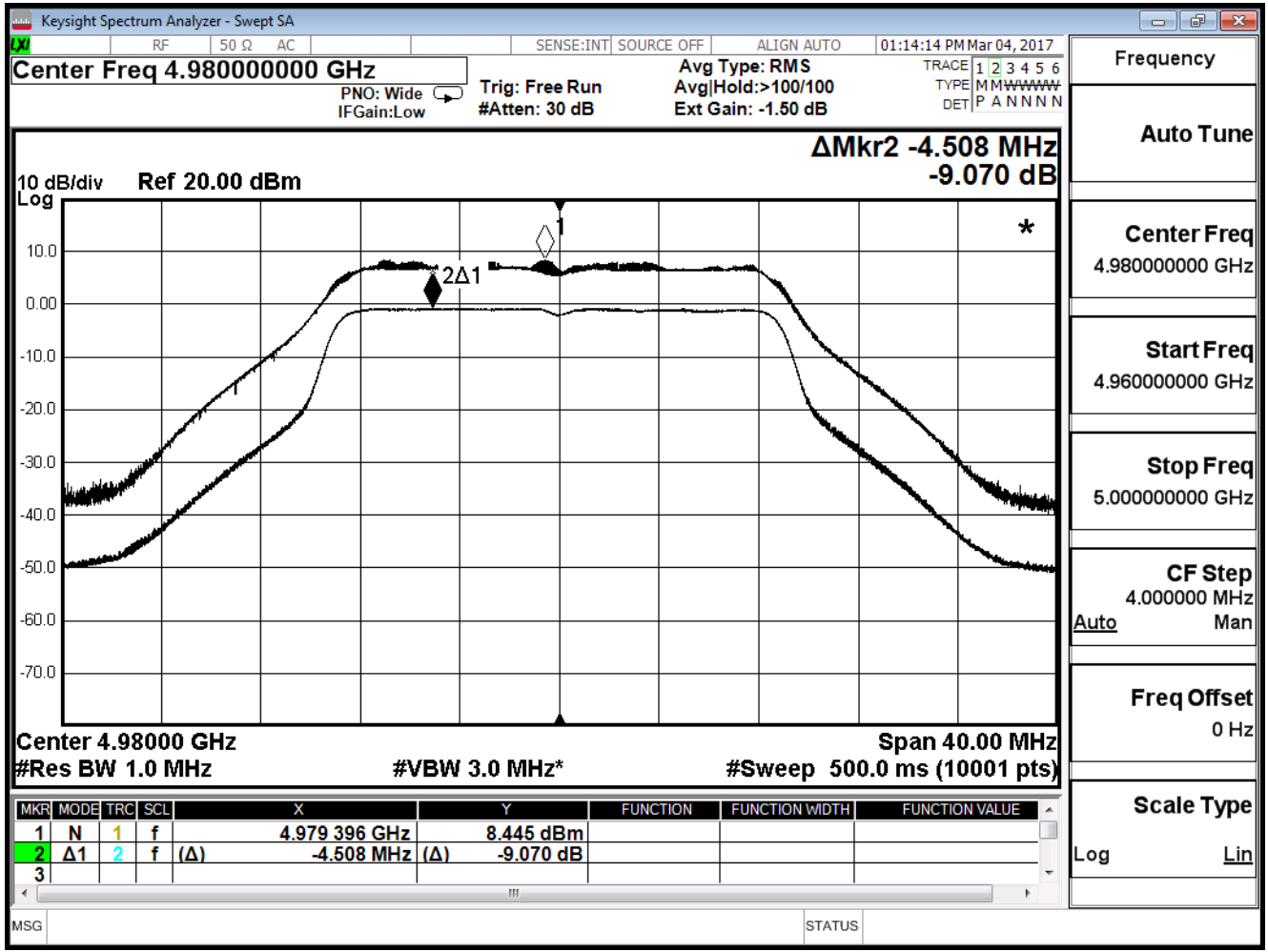

7. Frequency Stability

7.1. Test Equipment

The following test equipment's are used during the radiated emission tests:

Frequency Stability / SR10-H

Instrument	Manufacturer	Model No.	Serial No	Next Cal. Date
Spectrum Analyzer	Agilent	N9010A	US47140172	2017/08/08

Note: All equipment's that need to calibrate are with calibration period of 1 year.

7.2. Test Setup

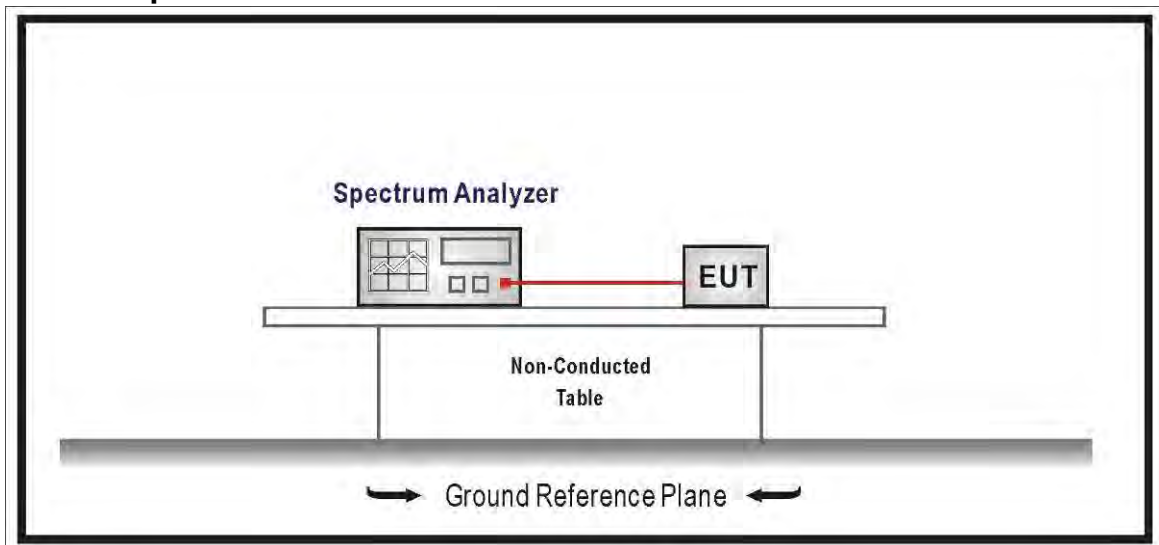

7.3. Limits

Manufactures of devices are responsible for ensuring frequency stability such that an emission is maintained within the band of operation under all conditions of normal operation as specified.

7.4. Test Procedure

TIA-603-C-2004, section 2.3.1 and 2.3.2.

The carrier frequency stability is the ability of the transmitter to maintain an assigned carrier frequency.

The EUT was evaluated over the temperature range -30°C to +50°C.

The temperature was initially set to -30°C and a 2-hour period was observed for stabilization of the EUT. The frequency stability was measured within one minute after application of primary power to the transmitter. The temperature was raised at intervals of 10°C through the range. A ½ hour period was observed to stabilize the EUT at each measurement step, and the frequency stability was measured within one minute after application of primary power to the transmitter. Additionally, the power supply voltage of the EUT was varied +/-15% nominal and range of input voltages.

7.5. Uncertainty

± 681.6 Hz

7.6. Test Result

Product	Mimosa C5c				
Test Item	Frequency Stability				
Test Mode	Mode 1: Transmit-Dish				
Date of Test	2017/03/03	Test Site	SR10-H		

Channel 190

Temp	Voltage	Frequency_ANT_0	PPM	Frequency_ANT_1	PPM
-30	93.5	4949.951645	-9.768687	4949.951435	-9.811111
	110	4949.951465	-9.805051	4949.951615	-9.774747
	126.5	4949.951615	-9.774747	4949.951645	-9.768687
20	93.5	4949.951405	-9.817172	4949.951705	-9.756566
	110	4949.951435	-9.811111	4949.951945	-9.708081
	126.5	4949.951465	-9.805051	4949.951795	-9.738384
50	93.5	4949.951675	-9.762626	4949.951645	-9.768687
	110	4949.951585	-9.780808	4949.951735	-9.750505
	126.5	4949.951675	-9.762626	4949.951675	-9.762626

Product	Mimosa C5c		
Test Item	Frequency Stability		
Test Mode	Mode 1: Transmit-Dish		
Date of Test	2017/03/03	Test Site	SR10-H

Channel 193

Temp	Voltage	Frequency_ANT_0	PPM	Frequency_ANT_1	PPM
-30	93.5	4964.950925	-9.884189	4964.950925	-9.884189
	110	4964.950805	-9.908359	4964.950955	-9.878147
	126.5	4964.950835	-9.902316	4964.951045	-9.860020
20	93.5	4964.950715	-9.926485	4964.950835	-9.902316
	110	4964.950595	-9.950655	4964.950715	-9.926485
	126.5	4964.950715	-9.926485	4964.950715	-9.926485
50	93.5	4964.950985	-9.872105	4964.951015	-9.866062
	110	4964.950835	-9.902316	4964.951105	-9.847936
	126.5	4964.951165	-9.835851	4964.950985	-9.872105

Product	Mimosa C5c		
Test Item	Frequency Stability		
Test Mode	Mode 1: Transmit-Dish		
Date of Test	2017/03/03	Test Site	SR10-H

Channel 196

Temp	Voltage	Frequency_ANT_0	PPM	Frequency_ANT_1	PPM
-30	93.5	4979.951885	-9.661647	4979.950445	-9.950803
	110	4979.952215	-9.595382	4979.950475	-9.944779
	126.5	4979.952095	-9.619478	4979.950565	-9.926707
20	93.5	4979.952605	-9.517068	4979.950505	-9.938755
	110	4979.952935	-9.450803	4979.950385	-9.962851
	126.5	4979.952365	-9.565261	4979.950505	-9.938755
50	93.5	4979.951615	-9.715863	4979.950445	-9.950803
	110	4979.951885	-9.661647	4979.950475	-9.944779
	126.5	4979.951615	-9.715863	4979.950475	-9.944779

Product	Mimosa C5c		
Test Item	Frequency Stability		
Test Mode	Mode 2: Transmit-Dipole		
Date of Test	2017/03/03	Test Site	SR10-H

Channel 190

Temp	Voltage	Frequency_ANT_0	PPM	Frequency_ANT_1	PPM
-30	93.5	4949.951645	-9.768687	4949.951435	-9.811111
	110	4949.951465	-9.805051	4949.951615	-9.774747
	126.5	4949.951615	-9.774747	4949.951645	-9.768687
20	93.5	4949.951405	-9.817172	4949.951705	-9.756566
	110	4949.951435	-9.811111	4949.951945	-9.708081
	126.5	4949.951465	-9.805051	4949.951795	-9.738384
50	93.5	4949.951675	-9.762626	4949.951645	-9.768687
	110	4949.951585	-9.780808	4949.951735	-9.750505
	126.5	4949.951675	-9.762626	4949.951675	-9.762626

Product	Mimosa C5c		
Test Item	Frequency Stability		
Test Mode	Mode 2: Transmit-Dipole		
Date of Test	2017/03/03	Test Site	SR10-H

Channel 193

Temp	Voltage	Frequency_ANT_0	PPM	Frequency_ANT_1	PPM
-30	93.5	4964.950925	-9.884189	4964.950925	-9.884189
	110	4964.950805	-9.908359	4964.950955	-9.878147
	126.5	4964.950835	-9.902316	4964.951045	-9.860020
20	93.5	4964.950715	-9.926485	4964.950835	-9.902316
	110	4964.950595	-9.950655	4964.950715	-9.926485
	126.5	4964.950715	-9.926485	4964.950715	-9.926485
50	93.5	4964.950985	-9.872105	4964.951015	-9.866062
	110	4964.950835	-9.902316	4964.951105	-9.847936
	126.5	4964.951165	-9.835851	4964.950985	-9.872105

Product	Mimosa C5c		
Test Item	Frequency Stability		
Test Mode	Mode 2: Transmit-Dipole		
Date of Test	2017/03/03	Test Site	SR10-H

Channel 196

Temp	Voltage	Frequency_ANT_0	PPM	Frequency_ANT_1	PPM
-30	93.5	4979.951885	-9.661647	4979.950445	-9.950803
	110	4979.952215	-9.595382	4979.950475	-9.944779
	126.5	4979.952095	-9.619478	4979.950565	-9.926707
20	93.5	4979.952605	-9.517068	4979.950505	-9.938755
	110	4979.952935	-9.450803	4979.950385	-9.962851
	126.5	4979.952365	-9.565261	4979.950505	-9.938755
50	93.5	4979.951615	-9.715863	4979.950445	-9.950803
	110	4979.951885	-9.661647	4979.950475	-9.944779
	126.5	4979.951615	-9.715863	4979.950475	-9.944779

8. Conductive Spurious Emission

8.1. Test Equipment

The following test equipment's are used during the radiated emission tests:

Conductive Spurious Emission / SR10-H

Instrument	Manufacturer	Model No.	Serial No	Next Cal. Date
Signal & Spectrum Analyzer	R&S	FSV40	101049	2018/01/22

Note: All equipment's that need to calibrate are with calibration period of 1 year.

8.2. Test Setup

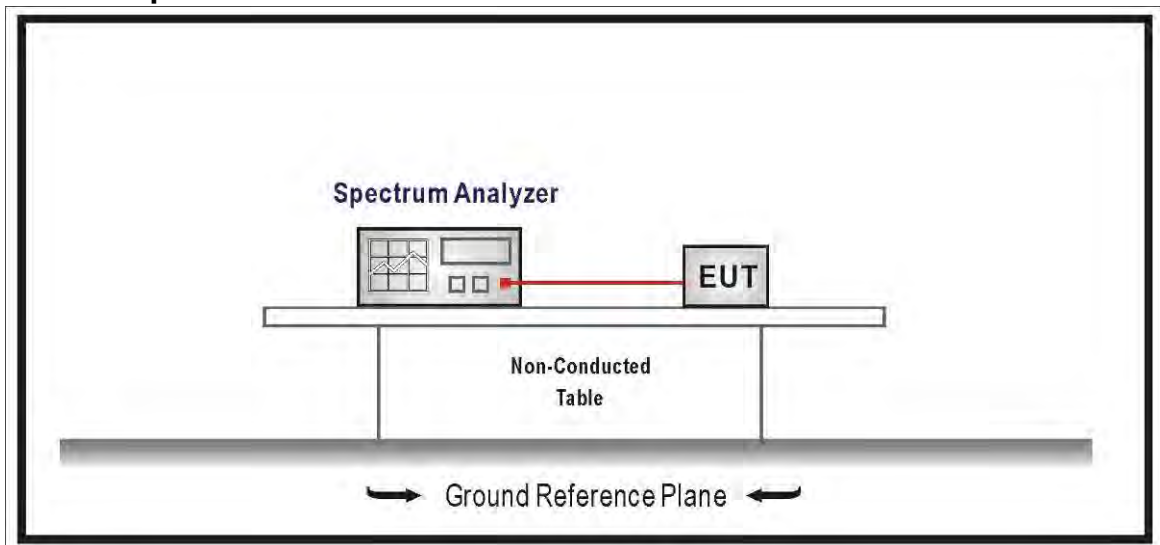

8.3. Limits

Low power transmitter $\leq 20\text{dBm}$	Low power transmitter $> 20\text{dBm}$
assigned frequency above 150% of the authorized bandwidth: 40 dBc.	assigned frequency between above 150% of the authorized bandwidth: 50 dB or $55 + 10 \log (P)$ dB, whichever is the lesser attenuation.

8.4. Test Procedure

Set RBW $\geq 1\%$ of OBW, VBW = 30kHz,, Test Range : 30MHz – 40GHz

8.5. Uncertainty

$\pm 1.27\text{dB}$

8.6. Test Result

Product	Mimosa C5c		
Test Item	Conductive Spurious Emission		
Test Mode	Mode 1: Transmit-Dish		
Date of Test	2017/04/13	Test Site	SR10-H

Channel 190 ANT0

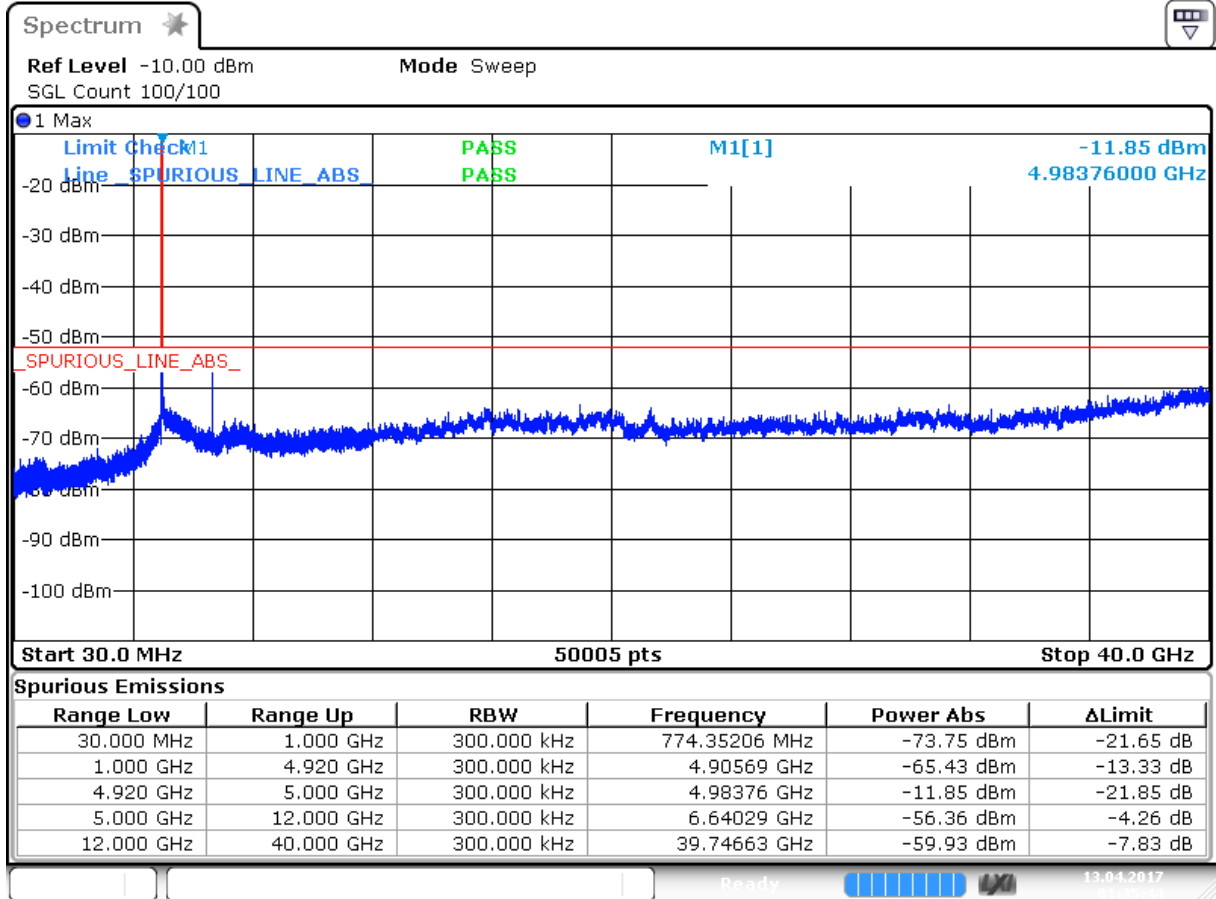

Date: 13 APR 2017 01:35:45

Channel 193 ANT0

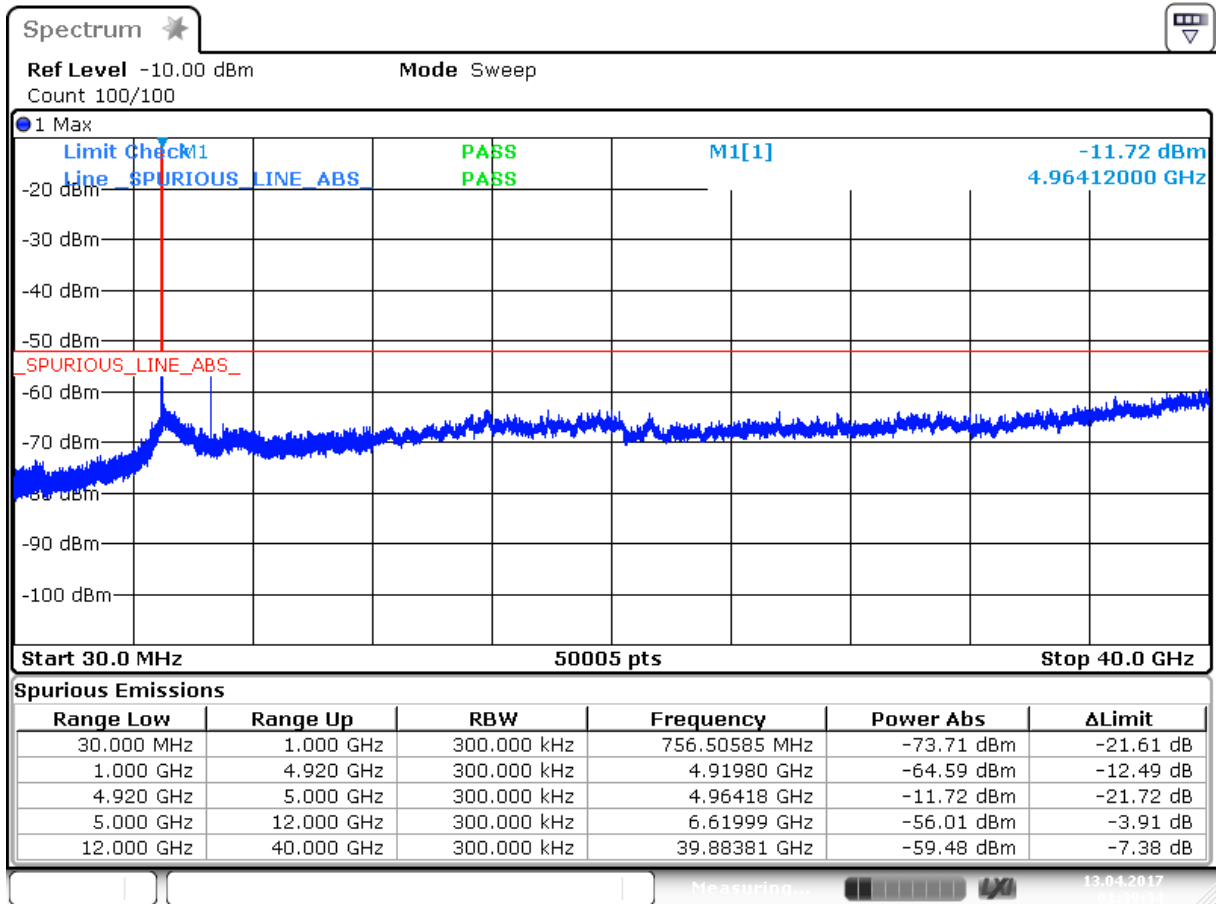

Date: 13 APR 2017 01:39:34

Channel 196 ANT0

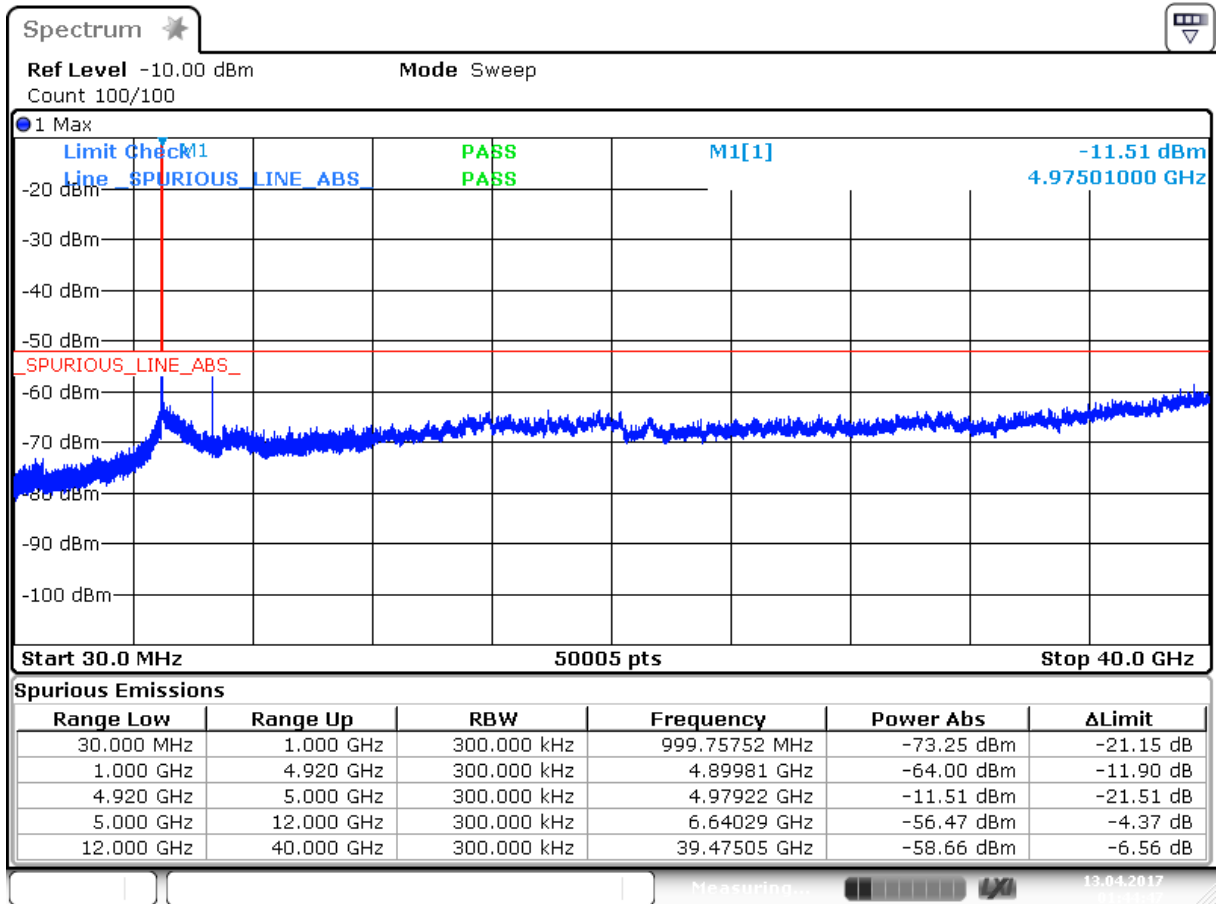

Date: 13 APR 2017 01:44:46

Channel 190 ANT1

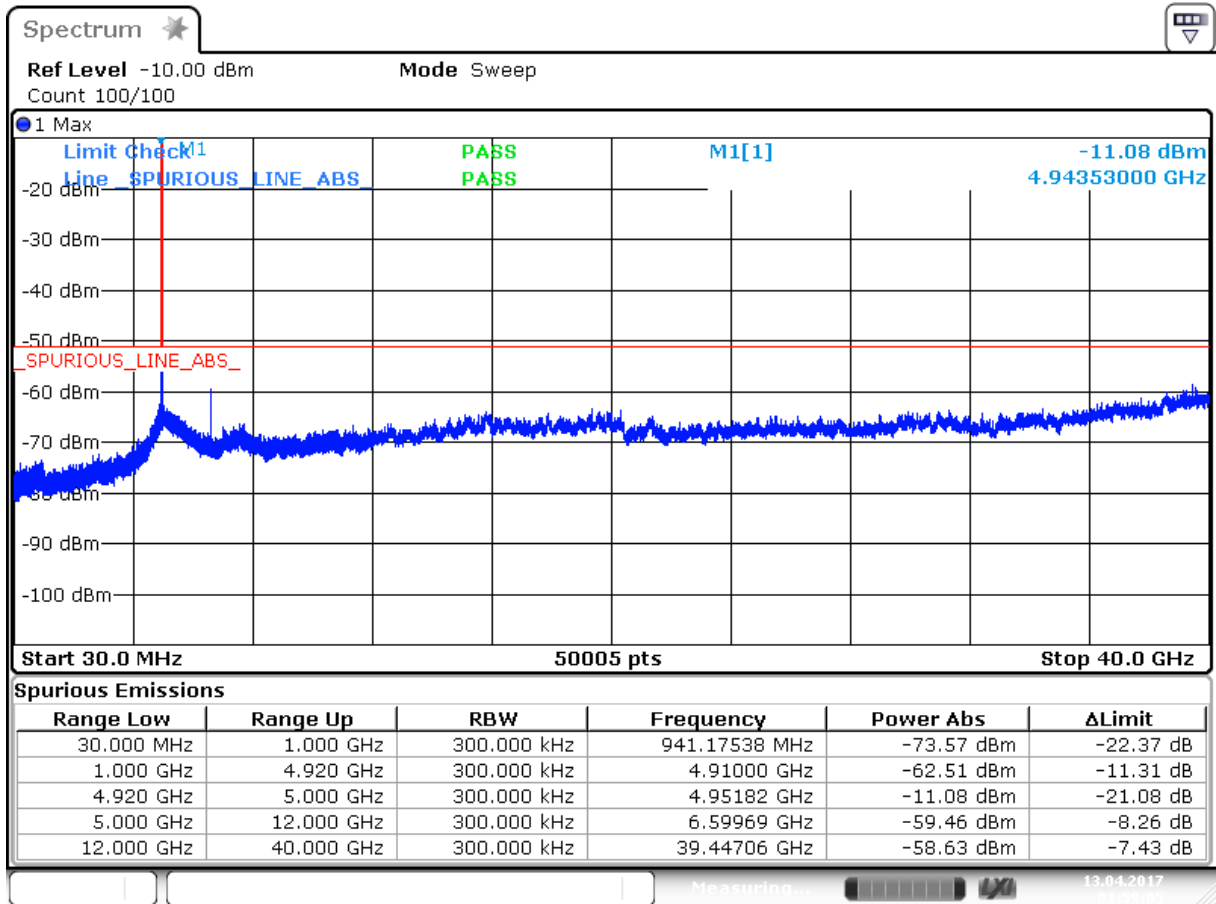

Date: 13 APR 2017 01:59:05

Channel 193 ANT1

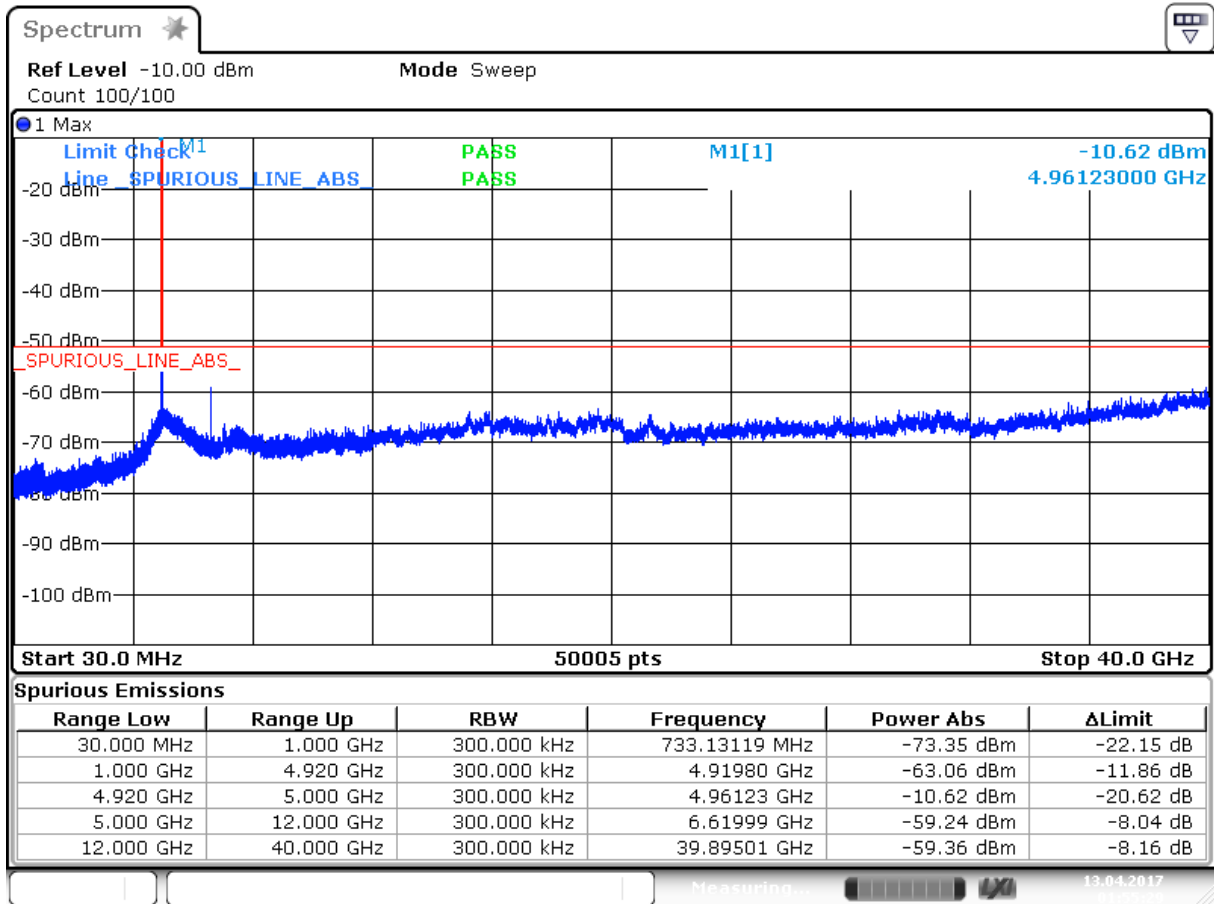

Date: 13 APR 2017 01:55:29

Channel 196 ANT1

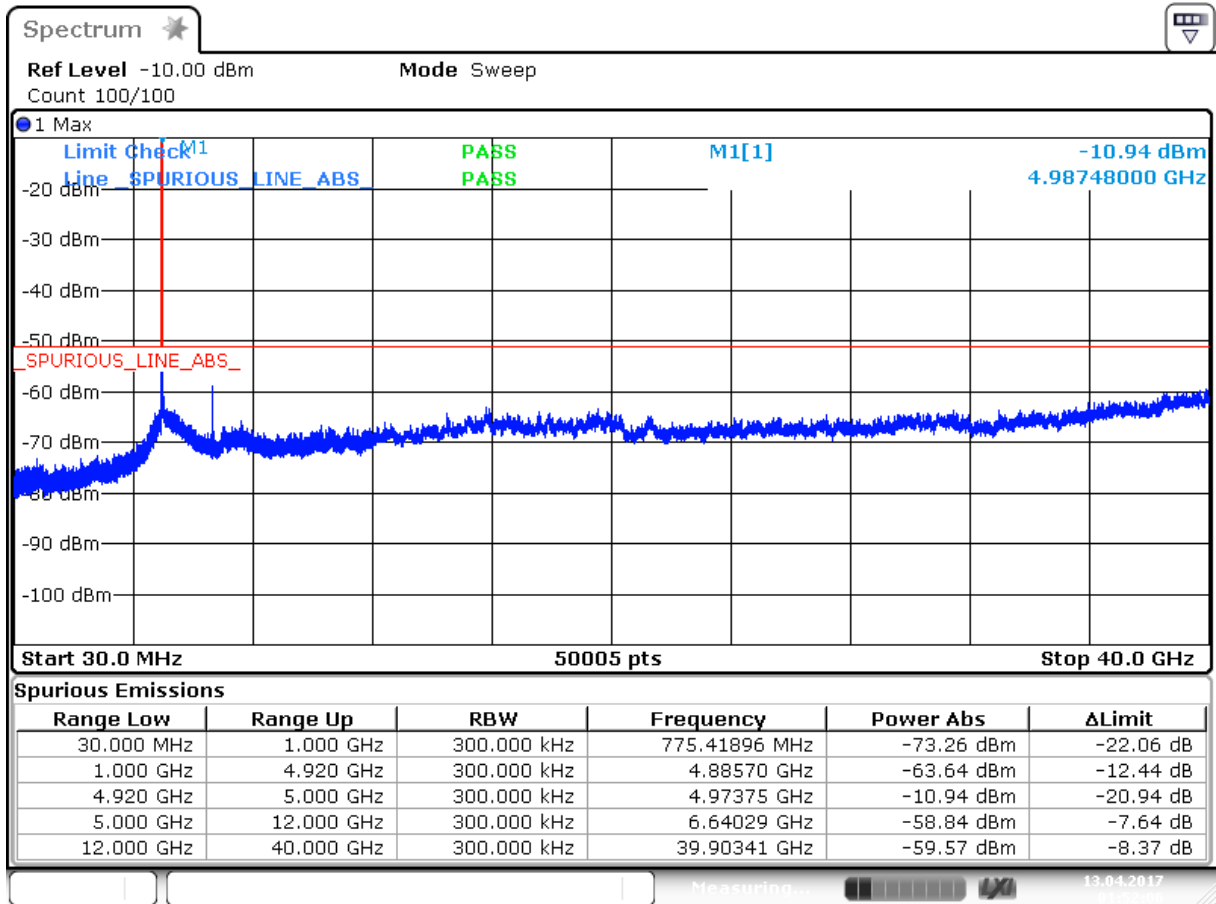

Date: 13 APR 2017 01:52:06

Product	Mimosa C5c		
Test Item	Conductive Spurious Emission		
Test Mode	Mode 2: Transmit-Dipole		
Date of Test	2017/03/04	Test Site	SR10-H

Channel 190 ANT0

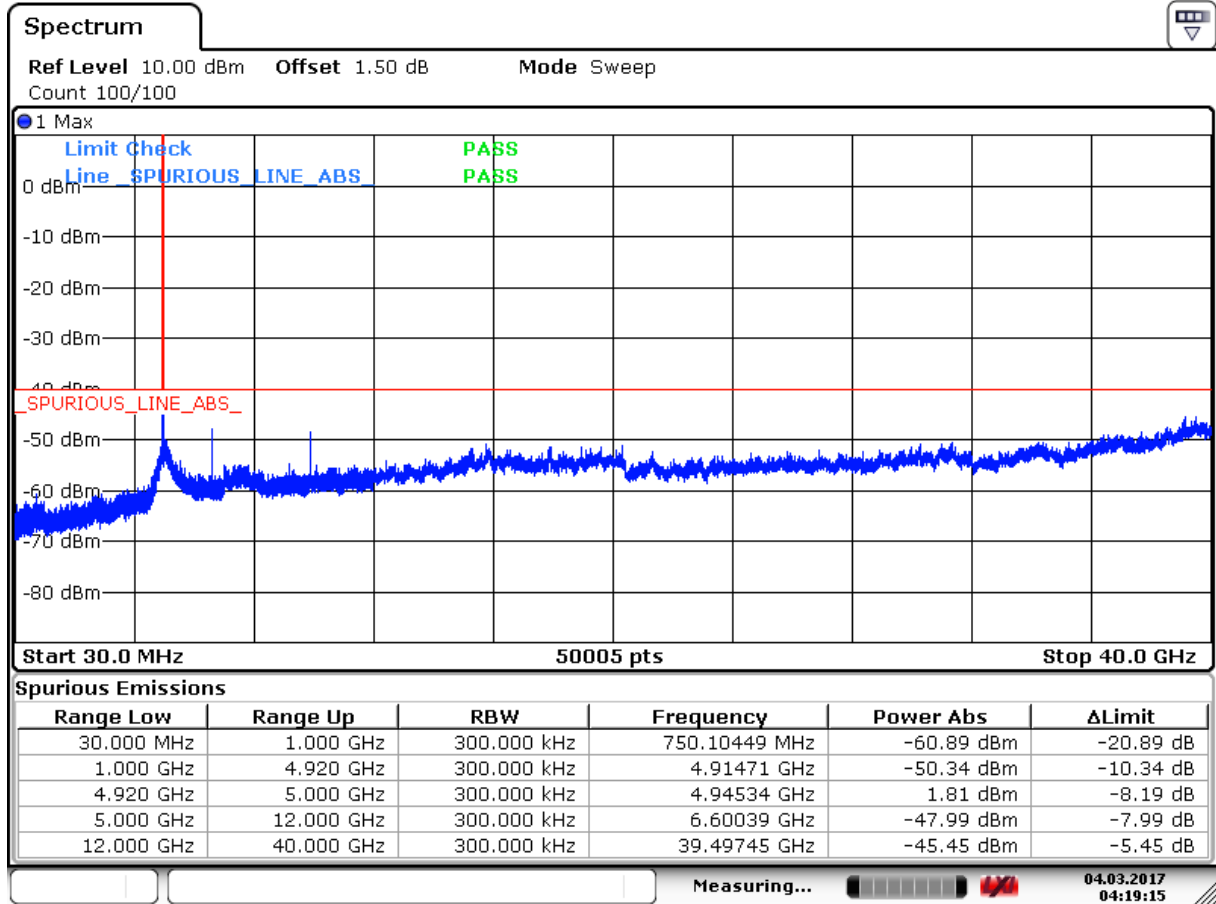

Date: 4 MAR 2017 04:19:15

Channel 193 ANT0

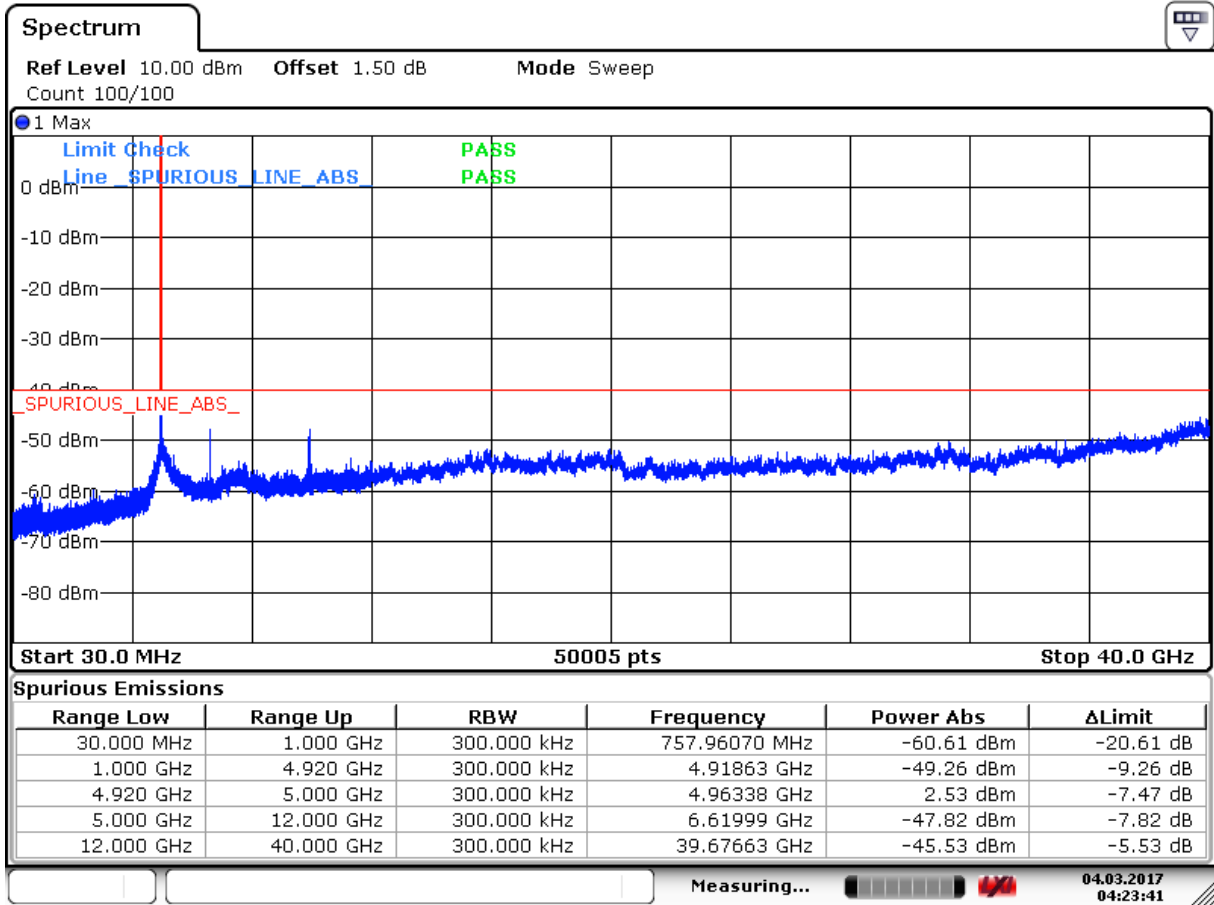

Date: 4 MAR 2017 04:23:41

Channel 196 ANT0

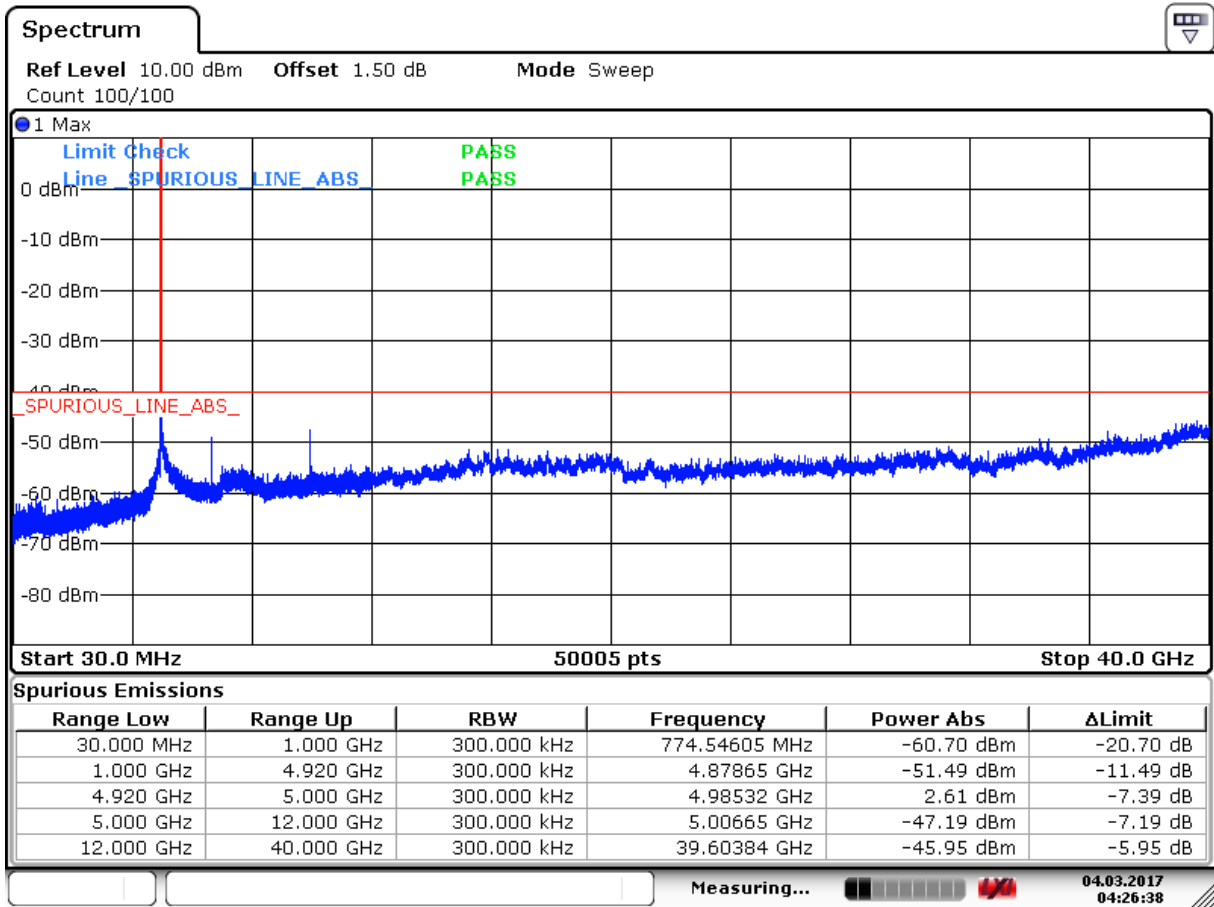

Date: 4 MAR 2017 04:26:38

Channel 190 ANT1

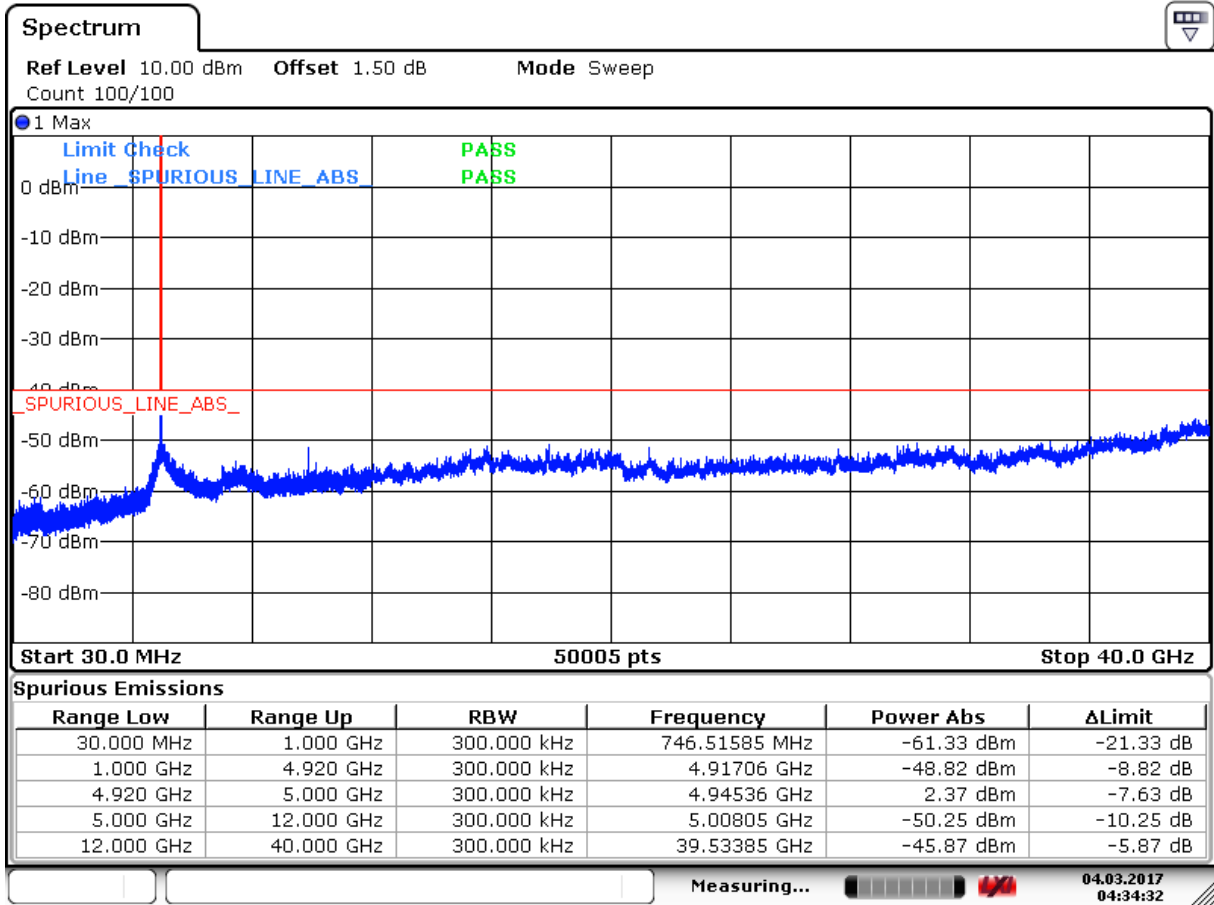

Date: 4 MAR 2017 04:34:31

Channel 193 ANT1

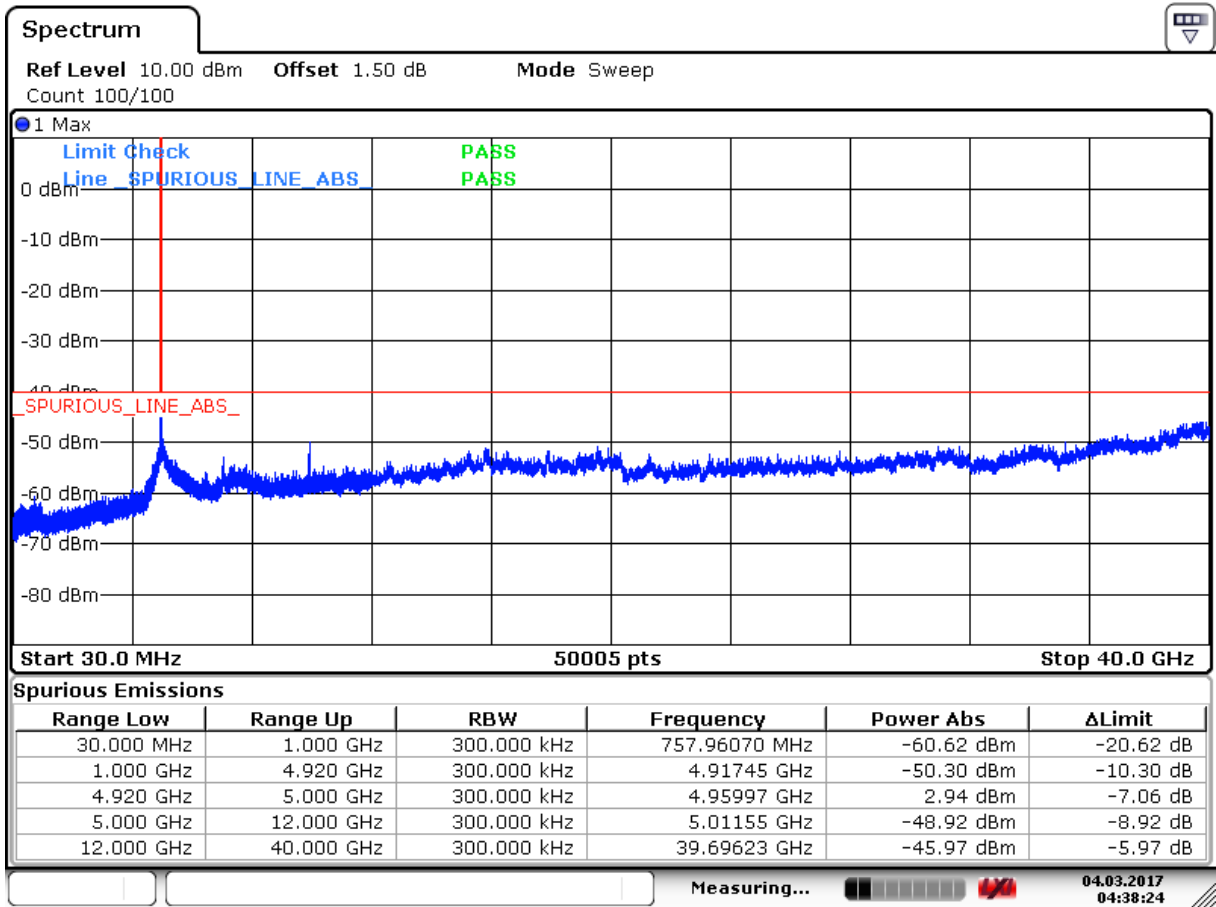

Date: 4 MAR 2017 04:38:24

Channel 196 ANT1

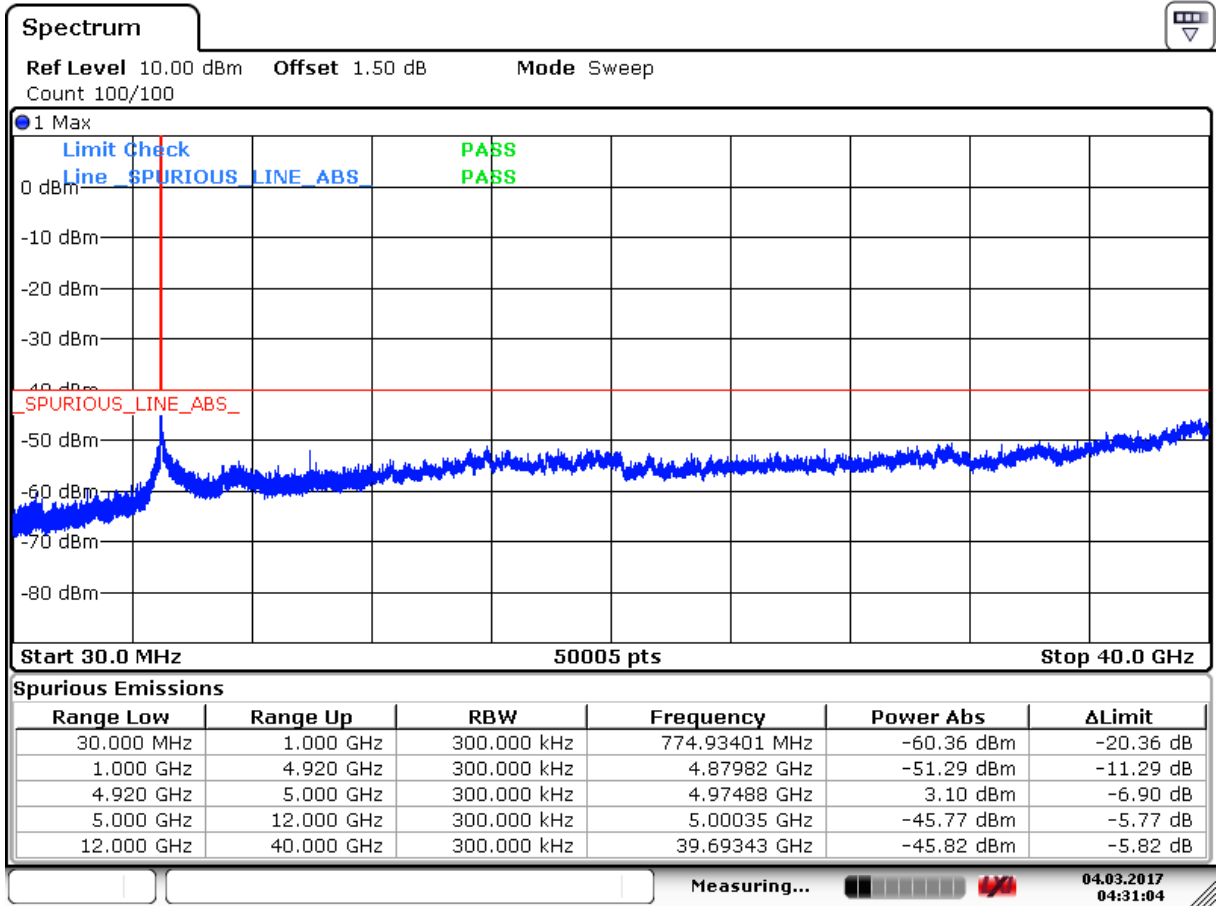

Date: 4 MAR 2017 04:31:04

9. Radiated Emission

9.1. Test Equipment

The following test equipments are used during the test:

Radiated Emission / CB2-H

Instrument	Manufacturer	Model No.	Serial No	Next Cal. Date
Bilog Antenna	Schaffner	CBL6112B	2891	2017/08/14
Horn Antenna	Schwarzbeck	BBHA 9120	D312	2017/10/25
Pre-Amplifier	EMCI	EMC0031835	980233	2018/02/02
Pre-Amplifier	Schwarzbeck	DBL-1840N506	013	2017/09/29
Pre-Amplifier	Miteq	JS41-001040000-58-5P	1573954	2017/10/04
Horn Antenna	Schwarzbeck	BBHA 9170	203	2017/08/28
Signal & Spectrum Analyzer	R&S	FSV40	101049	2018/01/22

Note: All equipments that need to calibrate are with calibration period of 1 year.

9.2. Test Setup

Under 1GHz Test Setup:

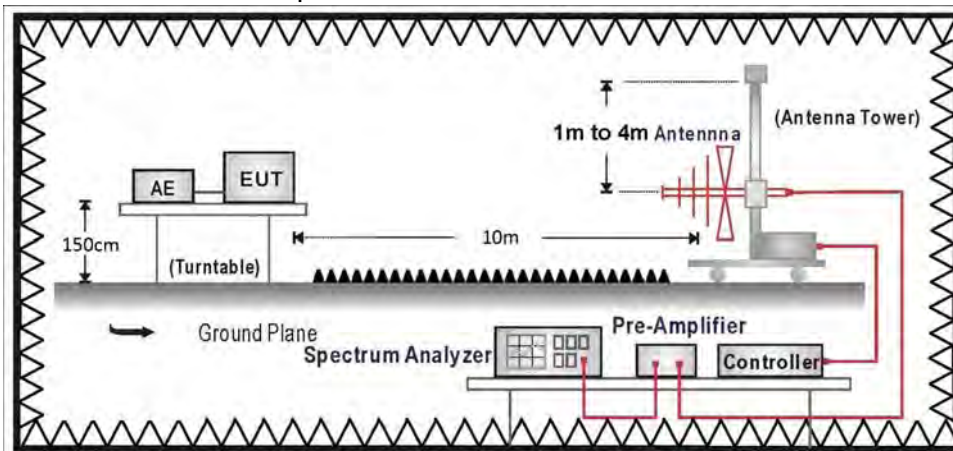

Above 1GHz Test Setup:

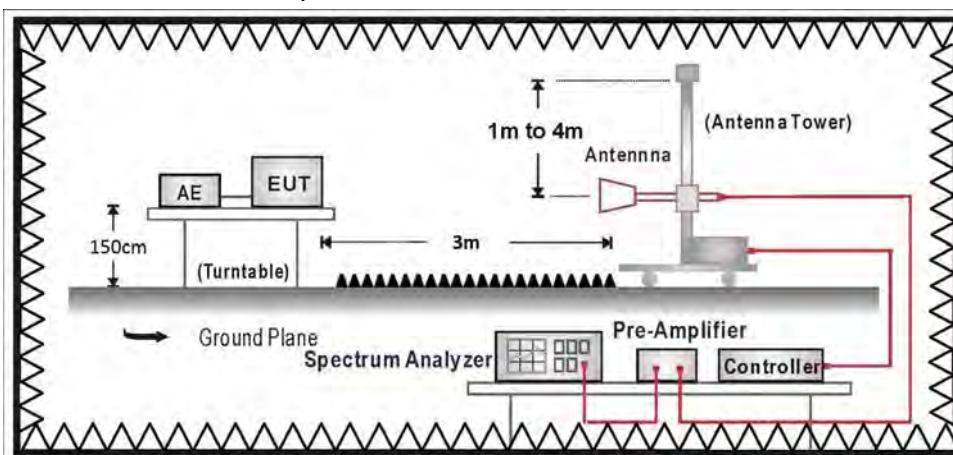

9.3. Limits

Low power transmitter $\leq 20\text{dBm}$	High power transmitter $> 20\text{dBm}$
assigned frequency above 150% of the authorized bandwidth: 40 dBc.	assigned frequency between above 150% of the authorized bandwidth: 50 dB or $55 + 10 \log (P)$ dB, whichever is the lesser attenuation.

9.4. Test Procedure

The EUT is placed on a turn table which is 0.8 meters above ground. The turn table can rotate 360 degrees to determine the position of the maximum emission level. The EUT was positioned such that the distance from antenna to the EUT was 3 meters. The antenna can move up and down between 1 meter and 4 meters to find out the maximum emission level. Broadband antenna (calibrated bi-log and horn antenna) are used as a receiving antenna. Both horizontal and vertical polarization of the antenna are set on measurement. And a high frequency preamplifier were used increase the sensitivity of the measuring. The additional notch filter below 1GHz was used to measure the level of harmonics radiated emission during field dtrength of harmonics measurement.

The frequency range from 9kHz to 40GHz is checked.

9.5. Uncertainty

± 4.08 dB above 1GHz

± 4.22 dB below 1GHz

9.6. Test Result

30MHz-1GHz Spurious:

Site : CB2-H	Time : 2017/04/19
Limit : FCC_90Y_03M_PK	Margin : 6
Probe : CB2_CE_Sub_30-1GHz_3M_0117 - HORIZONTAL	Power : AC 120V / 60Hz
EUT : Mimosa C5c	Note : 90Y_4965MHz_Mode 1: Transmit-Dish

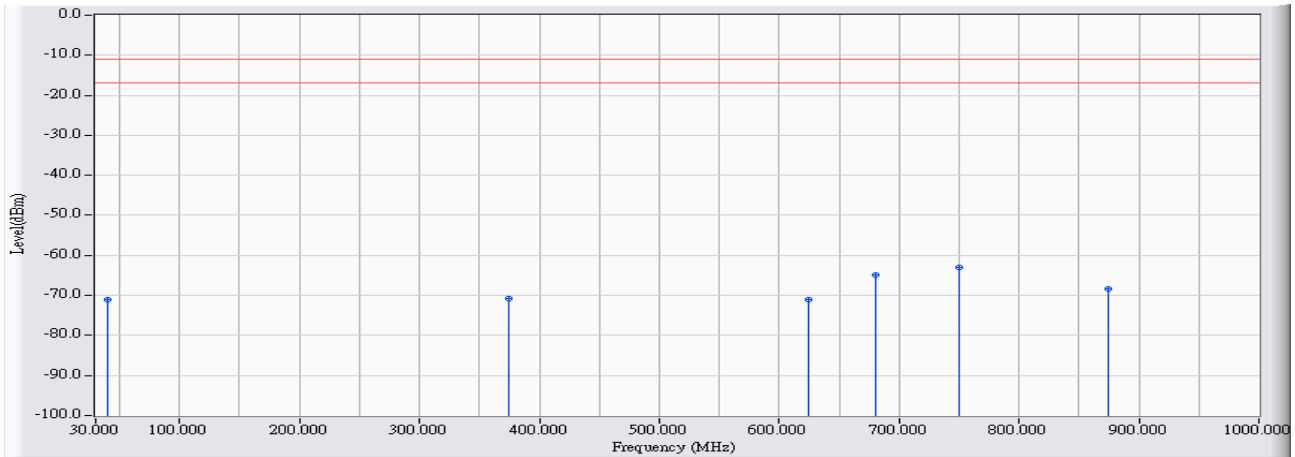

	Frequency (MHz)	Correct Factor (dB)	Reading Level (dBm)	Measure Level (dBm)	Margin (dB)	Limit (dBm)	Detector Type
1	39.408	-26.749	-44.269	-71.018	-60.018	-11.000	PEAK
2	374.995	-23.114	-47.652	-70.766	-59.766	-11.000	PEAK
3	624.939	-17.252	-53.755	-71.007	-60.007	-11.000	PEAK
4	679.932	-16.635	-48.261	-64.897	-53.897	-11.000	PEAK
5	* 749.959	-17.273	-45.847	-63.119	-52.119	-11.000	PEAK
6	874.980	-15.334	-52.948	-68.282	-57.282	-11.000	PEAK

Note:

1. All Reading Levels are Quasi-Peak value.
2. “ * ”, means this data is the worst emission level.
3. Measurement Level = Reading Level + Correct Factor.

Site : CB2-H	Time : 2017/04/19
Limit : FCC_90Y_03M_PK	Margin : 6
Probe : CB2_CE_Sub_30-1GHz_3M_0117 - VERTICAL	Power : AC 120V / 60Hz
EUT : Mimosa C5c	Note : 90Y_4965MHz_Mode 1: Transmit-Dish

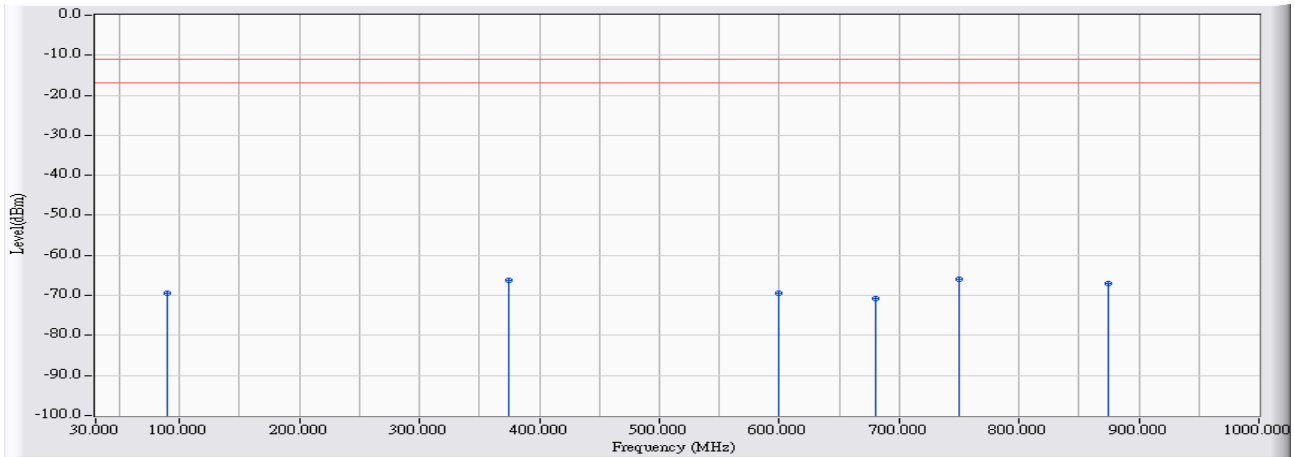

	Frequency (MHz)	Correct Factor (dB)	Reading Level (dBm)	Measure Level (dBm)	Margin (dB)	Limit (dBm)	Detector Type
1	89.358	-22.615	-46.747	-69.362	-58.362	-11.000	PEAK
2	374.995	-21.912	-44.332	-66.244	-55.244	-11.000	PEAK
3	599.915	-17.035	-52.402	-69.437	-58.437	-11.000	PEAK
4	679.932	-16.348	-54.303	-70.652	-59.652	-11.000	PEAK
5	* 749.959	-15.870	-50.101	-65.971	-54.971	-11.000	PEAK
6	874.980	-14.795	-52.324	-67.119	-56.119	-11.000	PEAK

Note:

1. All Reading Levels are Quasi-Peak value.
2. “ * ”, means this data is the worst emission level.
3. Measurement Level = Reading Level + Correct Factor.

Site : CB2-H	Time : 2017/04/19
Limit : FCC_90Y_03M_QP	Margin : 6
Probe : CB2_CE_Sub_30-1GHz_3M_0117 - HORIZONTAL	Power : AC 120V / 60Hz
EUT : Mimoso C5c	Note : 90Y_4965MHz_Mode 2: Transmit-Dipole

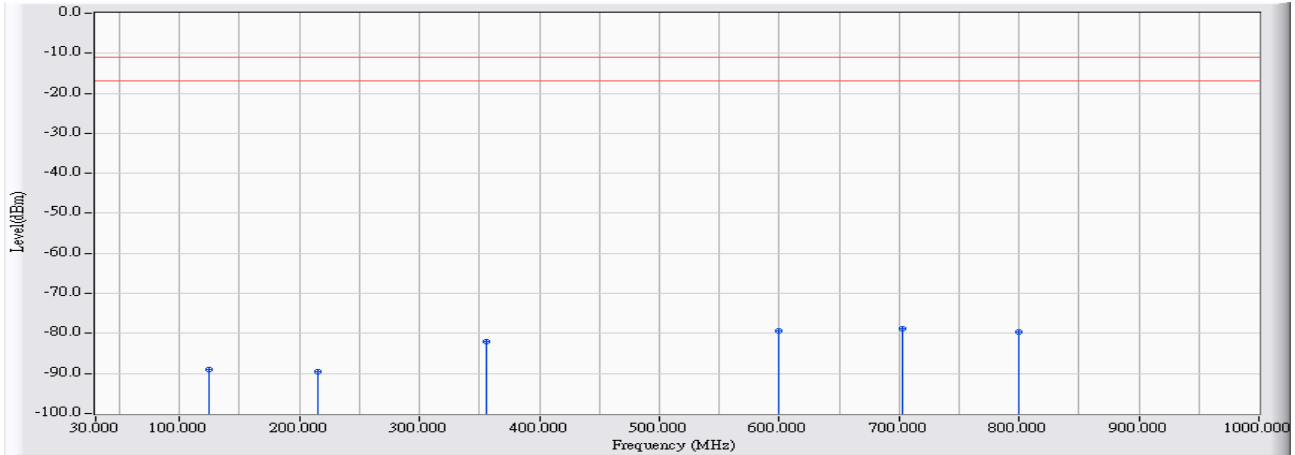

	Frequency (MHz)	Correct Factor (dB)	Reading Level (dBm)	Measure Level (dBm)	Margin (dB)	Limit (dBm)	Detector Type
1	124.954	-28.145	-60.948	-89.092	-78.092	-11.000	PEAK
2	214.767	-29.320	-60.212	-89.533	-78.533	-11.000	PEAK
3	* 355.402	-22.805	-59.228	-82.033	-71.033	-11.000	PEAK
4	599.915	-18.226	-61.016	-79.242	-68.242	-11.000	PEAK
5	* 703.307	-17.802	-60.988	-78.790	-67.790	-11.000	PEAK
6	799.909	-17.293	-62.388	-79.680	-68.680	-11.000	PEAK

Note:

1. All Reading Levels are Quasi-Peak value.
2. “ * ”, means this data is the worst emission level.
3. Measurement Level = Reading Level + Correct Factor.

Site : CB2-H	Time : 2017/04/19
Limit : FCC_90Y_03M_PK	Margin : 6
Probe : CB2_CE_Sub_30-1GHz_3M_0117 - VERTICAL	Power : AC 120V / 60Hz
EUT : Mimoso C5c	Note : 90Y_4965MHz_Mode 2: Transmit-Dipole

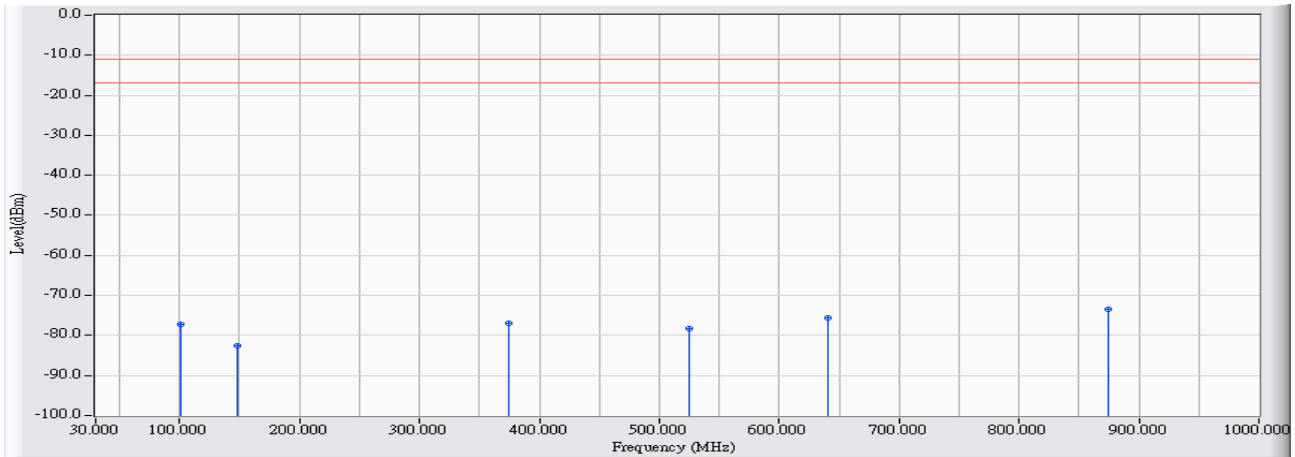

		Frequency (MHz)	Correct Factor (dB)	Reading Level (dBm)	Measure Level (dBm)	Margin (dB)	Limit (dBm)	Detector Type
1	*	100.803	-21.185	-56.010	-77.195	-66.195	-11.000	PEAK
2		148.716	-24.756	-57.872	-82.628	-71.628	-11.000	PEAK
3	*	374.995	-21.912	-55.141	-77.053	-66.053	-11.000	PEAK
4		524.942	-17.893	-60.493	-78.385	-67.385	-11.000	PEAK
5		640.069	-16.848	-58.632	-75.480	-64.480	-11.000	PEAK
6	*	874.980	-14.795	-58.534	-73.329	-62.329	-11.000	PEAK

Note:

1. All Reading Levels are Quasi-Peak value.
2. “ * ”, means this data is the worst emission level.
3. Measurement Level = Reading Level + Correct Factor.

Above 1GHz Spurious:

Site : CB2-H	Time : 2017/04/17
Limit :FCC_90Y_03M_PK	Margin : 6
Probe : CB2_CE_Sub_B091_1-18GHz_3M_0117 - HORIZONTAL	Power : AC 120V / 60Hz
EUT : Mimoso C5c	Note : 90Y_4950MHz_Mode 1: Transmit-Dish

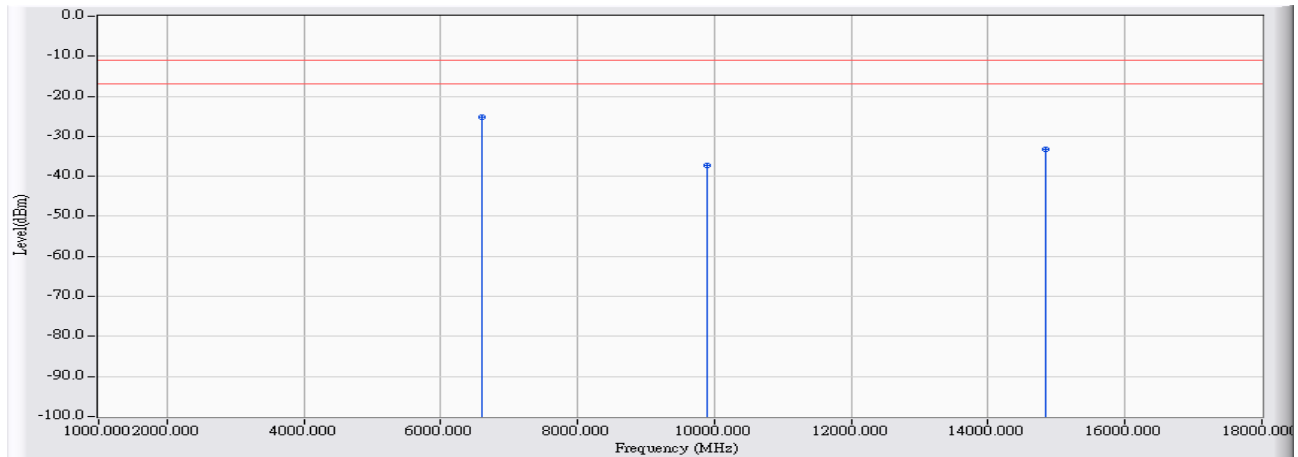

		Frequency (MHz)	Correct Factor (dB)	Reading Level (dBm)	Measure Level (dBm)	Margin (dB)	Limit (dBm)	Detector Type
1	*	6600.000	16.172	-41.420	-25.248	-14.248	-11.000	PEAK
2		9900.000	26.090	-63.280	-37.189	-26.189	-11.000	PEAK
3		14850.000	38.154	-71.320	-33.166	-22.166	-11.000	PEAK

Note:

1. All Readings below 1GHz are Quasi-Peak, above 1GHz are performed with peak and/or average measurements as necessary.
2. Peak measurements: RBW = 1MHz, VBW = 1MHz, Sweep: Auto.
3. Average measurements: RBW = 1MHz, VBW = 10 Hz, Sweep: Auto.
4. “ * ”, means this data is the worst emission level.
5. Measurement Level = Reading Level + Correct Factor.
6. The average measurement was not performed when the peak measured data under the limit of average detection.

Site : CB2-H	Time : 2017/04/17
Limit :FCC_90Y_03M_PK	Margin : 6
Probe : CB2_CE_Sub_B091_1-18GHz_3M_0117 - VERTICAL	Power : AC 120V / 60Hz
EUT : Mimosa C5c	Note : 90Y_4950MHz_Mode 1: Transmit-Dish

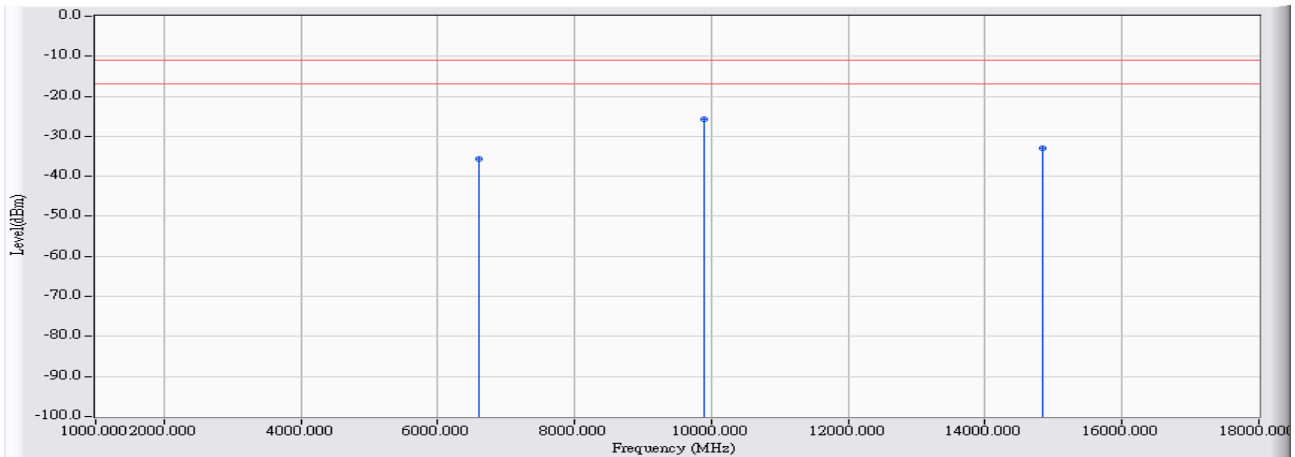

	Frequency (MHz)	Correct Factor (dB)	Reading Level (dBm)	Measure Level (dBm)	Margin (dB)	Limit (dBm)	Detector Type
1	6600.000	15.886	-51.420	-35.534	-24.534	-11.000	PEAK
2	* 9900.000	25.763	-51.420	-25.656	-14.656	-11.000	PEAK
3	14850.000	37.831	-70.830	-32.998	-21.998	-11.000	PEAK

Note:

1. All Readings below 1GHz are Quasi-Peak, above 1GHz are performed with peak and/or average measurements as necessary.
2. Peak measurements: RBW = 1MHz, VBW = 1MHz, Sweep: Auto.
3. Average measurements: RBW = 1MHz, VBW = 10 Hz, Sweep: Auto.
4. “ * ”, means this data is the worst emission level.
5. Measurement Level = Reading Level + Correct Factor.
6. The average measurement was not performed when the peak measured data under the limit of average detection.

Site : CB2-H	Time : 2017/04/17
Limit :FCC_90Y_03M_PK	Margin : 6
Probe : CB2_CE_Sub_B091_1-18GHz_3M_0117 - HORIZONTAL	Power : AC 120V / 60Hz
EUT : Mimoso C5c	Note : 90Y_4965MHz_Mode 1: Transmit-Dish

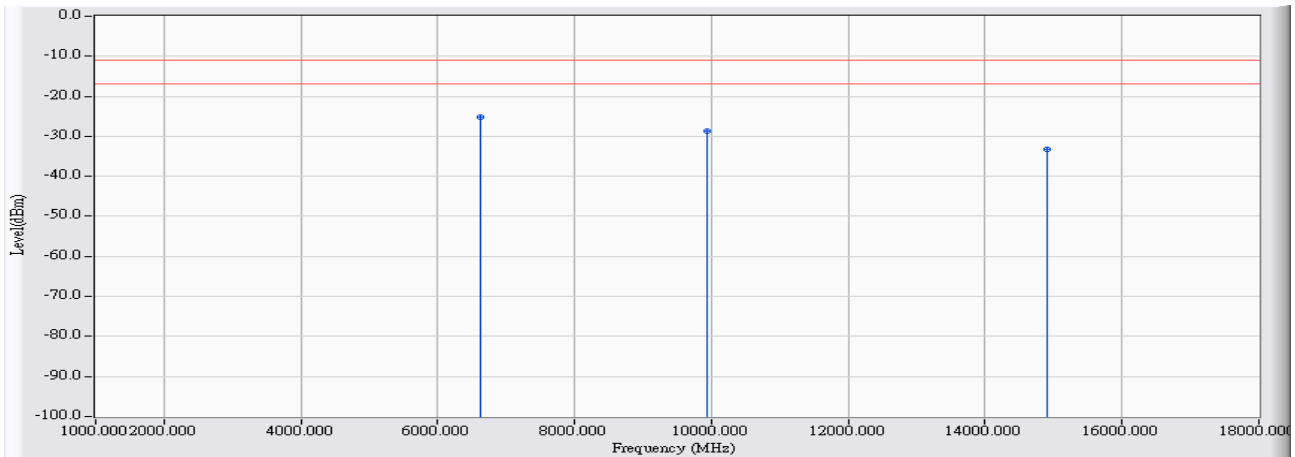

		Frequency (MHz)	Correct Factor (dB)	Reading Level (dBm)	Measure Level (dBm)	Margin (dB)	Limit (dBm)	Detector Type
1	*	6620.000	15.900	-41.130	-25.230	-14.230	-11.000	PEAK
2		9930.000	26.318	-54.870	-28.552	-17.552	-11.000	PEAK
3		14895.000	37.324	-70.550	-33.226	-22.226	-11.000	PEAK

Note:

1. All Readings below 1GHz are Quasi-Peak, above 1GHz are performed with peak and/or average measurements as necessary.
2. Peak measurements: RBW = 1MHz, VBW = 1MHz, Sweep: Auto.
3. Average measurements: RBW = 1MHz, VBW = 10 Hz, Sweep: Auto.
4. “ * ”, means this data is the worst emission level.
5. Measurement Level = Reading Level + Correct Factor.
6. The average measurement was not performed when the peak measured data under the limit of average detection.

Site : CB2-H	Time : 2017/04/17
Limit :FCC_90Y_03M_PK	Margin : 6
Probe : CB2_CE_Sub_B091_1-18GHz_3M_0117 - VERTICAL	Power : AC 120V / 60Hz
EUT : Mimosa C5c	Note : 90Y_4965MHz_Mode 1: Transmit-Dish

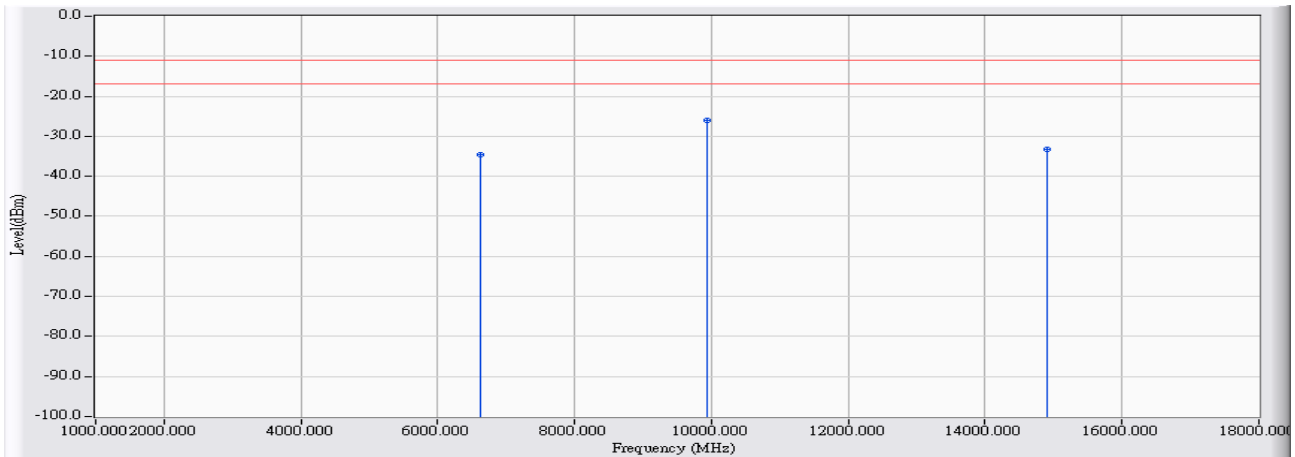

	Frequency (MHz)	Correct Factor (dB)	Reading Level (dBm)	Measure Level (dBm)	Margin (dB)	Limit (dBm)	Detector Type
1	6620.000	15.900	-50.550	-34.650	-23.650	-11.000	PEAK
2	* 9930.000	26.048	-51.940	-25.892	-14.892	-11.000	PEAK
3	14895.000	37.039	-70.320	-33.281	-22.281	-11.000	PEAK

Note:

1. All Readings below 1GHz are Quasi-Peak, above 1GHz are performed with peak and/or average measurements as necessary.
2. Peak measurements: RBW = 1MHz, VBW = 1MHz, Sweep: Auto.
3. Average measurements: RBW = 1MHz, VBW = 10 Hz, Sweep: Auto.
4. “ * ”, means this data is the worst emission level.
5. Measurement Level = Reading Level + Correct Factor.
6. The average measurement was not performed when the peak measured data under the limit of average detection.

Site : CB2-H	Time : 2017/04/17
Limit :FCC_90Y_03M_PK	Margin : 6
Probe : CB2_CE_Sub_B091_1-18GHz_3M_0117 - HORIZONTAL	Power : AC 120V / 60Hz
EUT : Mimoso C5c	Note : 90Y_4980MHz_Mode 1: Transmit-Dish

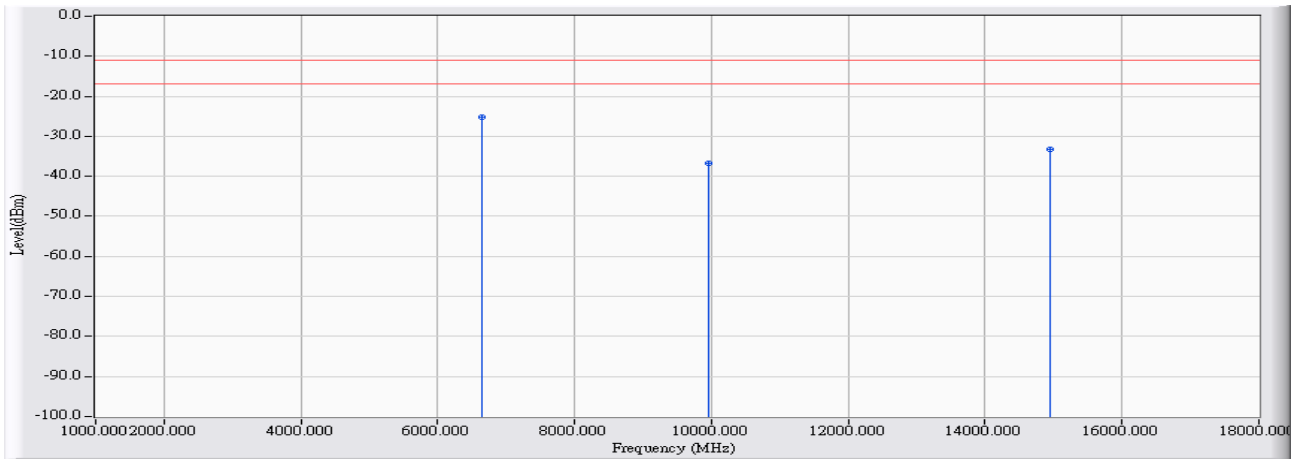

		Frequency (MHz)	Correct Factor (dB)	Reading Level (dBm)	Measure Level (dBm)	Margin (dB)	Limit (dBm)	Detector Type
1	*	6640.000	16.195	-41.440	-25.245	-14.245	-11.000	PEAK
2		9960.000	26.545	-63.330	-36.785	-25.785	-11.000	PEAK
3		14940.000	36.491	-69.800	-33.309	-22.309	-11.000	PEAK

Note:

1. All Readings below 1GHz are Quasi-Peak, above 1GHz are performed with peak and/or average measurements as necessary.
2. Peak measurements: RBW = 1MHz, VBW = 1MHz, Sweep: Auto.
3. Average measurements: RBW = 1MHz, VBW = 10 Hz, Sweep: Auto.
4. “ * ”, means this data is the worst emission level.
5. Measurement Level = Reading Level + Correct Factor.
6. The average measurement was not performed when the peak measured data under the limit of average detection.

Site : CB2-H	Time : 2017/04/17
Limit :FCC_90Y_03M_PK	Margin : 6
Probe : CB2_CE_Sub_B091_1-18GHz_3M_0117 - VERTICAL	Power : AC 120V / 60Hz
EUT : Mimosa C5c	Note : 90Y_4980MHz_Mode 1: Transmit-Dish

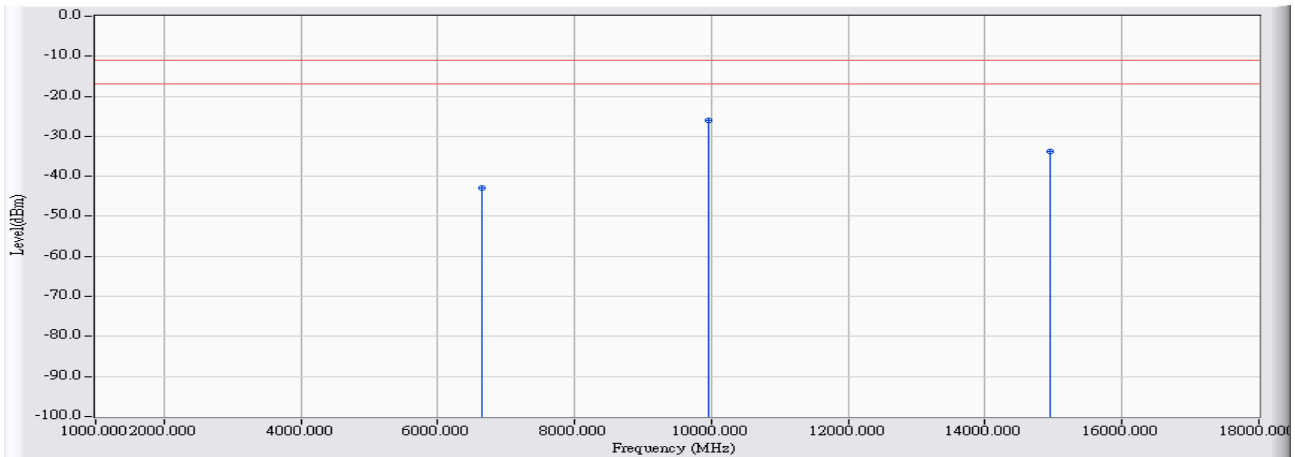

	Frequency (MHz)	Correct Factor (dB)	Reading Level (dBm)	Measure Level (dBm)	Margin (dB)	Limit (dBm)	Detector Type
1	6640.000	15.914	-58.870	-42.956	-31.956	-11.000	PEAK
2	* 9960.000	26.333	-52.420	-26.087	-15.087	-11.000	PEAK
3	14940.000	36.244	-70.030	-33.786	-22.786	-11.000	PEAK

Note:

1. All Readings below 1GHz are Quasi-Peak, above 1GHz are performed with peak and/or average measurements as necessary.
2. Peak measurements: RBW = 1MHz, VBW = 1MHz, Sweep: Auto.
3. Average measurements: RBW = 1MHz, VBW = 10 Hz, Sweep: Auto.
4. “ * ”, means this data is the worst emission level.
5. Measurement Level = Reading Level + Correct Factor.
6. The average measurement was not performed when the peak measured data under the limit of average detection.

Site : CB2-H	Time : 2017/04/17
Limit : FCC_90Y_03M_PK	Margin : 6
Probe : CB2_CE_Sub_B091_1-18GHz_3M_0117 - HORIZONTAL	Power : AC 120V / 60Hz
EUT : Mimoso C5c	Note : 90Y_4950MHz_ Mode 2: Transmit-Dipole

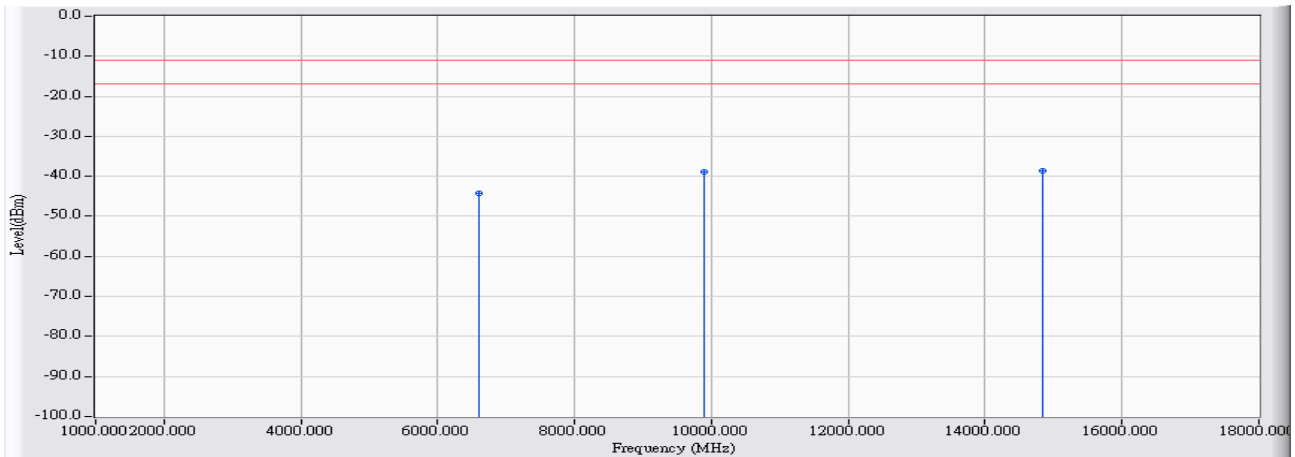

	Frequency (MHz)	Correct Factor (dB)	Reading Level (dBm)	Measure Level (dBm)	Margin (dB)	Limit (dBm)	Detector Type
1	6600.000	16.172	-60.460	-44.288	-33.288	-11.000	PEAK
2	9900.000	26.090	-65.040	-38.949	-27.949	-11.000	PEAK
3	* 14850.000	38.154	-76.880	-38.726	-27.726	-11.000	PEAK

Note:

1. All Readings below 1GHz are Quasi-Peak, above 1GHz are performed with peak and/or average measurements as necessary.
2. Peak measurements: RBW = 1MHz, VBW = 1MHz, Sweep: Auto.
3. Average measurements: RBW = 1MHz, VBW = 10 Hz, Sweep: Auto.
4. “ * ”, means this data is the worst emission level.
5. Measurement Level = Reading Level + Correct Factor.
6. The average measurement was not performed when the peak measured data under the limit of average detection.

Site : CB2-H	Time : 2017/04/17
Limit : FCC_90Y_03M_PK	Margin : 6
Probe : CB2_CE_Sub_B091_1-18GHz_3M_0117 - VERTICAL	Power : AC 120V / 60Hz
EUT : Mimosa C5c	Note : 90Y_4950MHz_ Mode 2: Transmit-Dipole

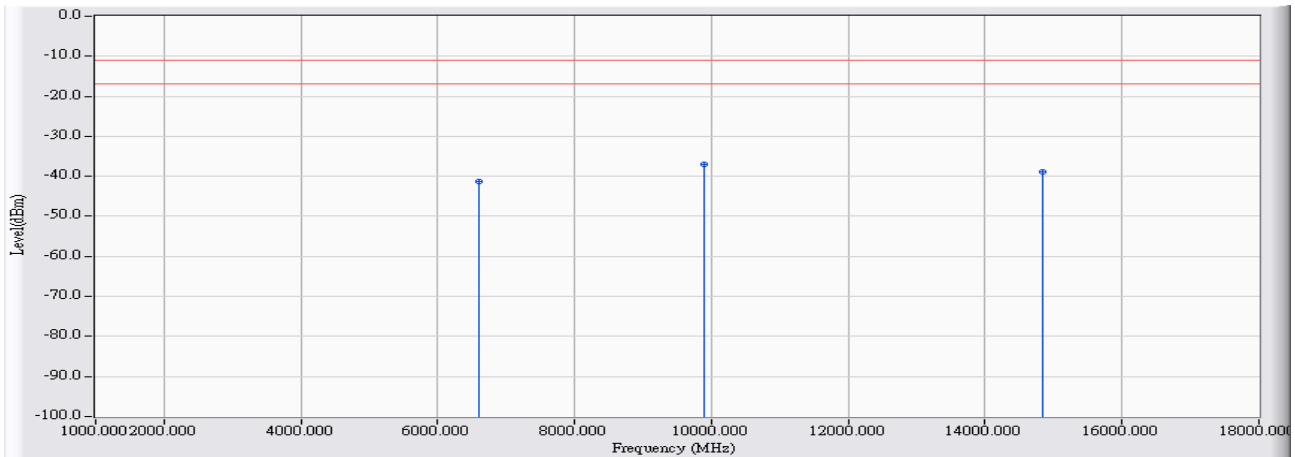

	Frequency (MHz)	Correct Factor (dB)	Reading Level (dBm)	Measure Level (dBm)	Margin (dB)	Limit (dBm)	Detector Type
1	6600.000	15.886	-57.250	-41.364	-30.364	-11.000	PEAK
2	* 9900.000	25.763	-62.640	-36.876	-25.876	-11.000	PEAK
3	14850.000	37.831	-76.590	-38.758	-27.758	-11.000	PEAK

Note:

1. All Readings below 1GHz are Quasi-Peak, above 1GHz are performed with peak and/or average measurements as necessary.
2. Peak measurements: RBW = 1MHz, VBW = 1MHz, Sweep: Auto.
3. Average measurements: RBW = 1MHz, VBW = 10 Hz, Sweep: Auto.
4. “ * ”, means this data is the worst emission level.
5. Measurement Level = Reading Level + Correct Factor.
6. The average measurement was not performed when the peak measured data under the limit of average detection.

Site : CB2-H	Time : 2017/04/17
Limit : FCC_90Y_03M_PK	Margin : 6
Probe : CB2_CE_Sub_B091_1-18GHz_3M_0117 - HORIZONTAL	Power : AC 120V / 60Hz
EUT : Mimoso C5c	Note : 90Y_4965MHz_ Mode 2: Transmit-Dipole

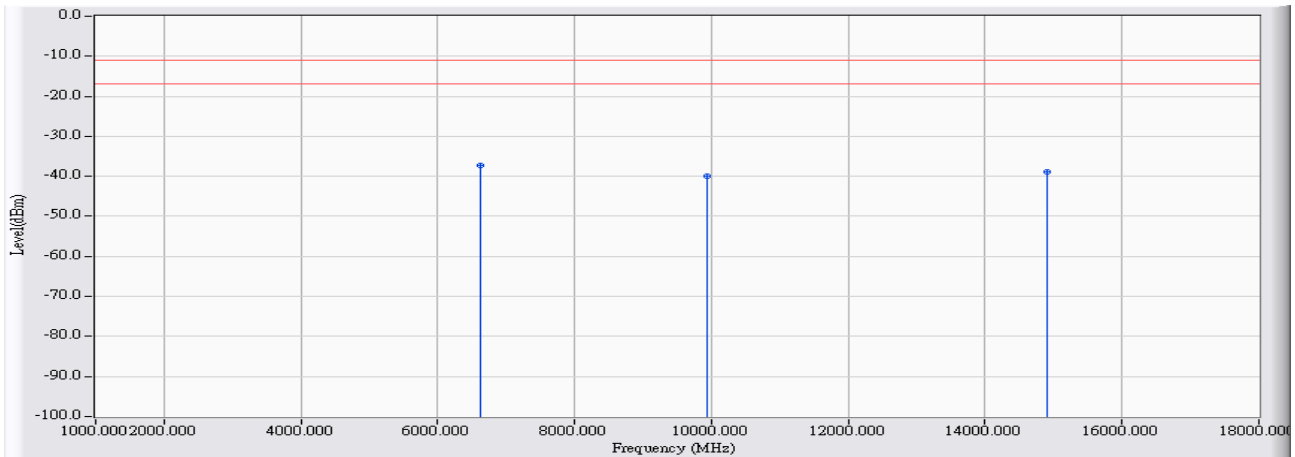

		Frequency (MHz)	Correct Factor (dB)	Reading Level (dBm)	Measure Level (dBm)	Margin (dB)	Limit (dBm)	Detector Type
1	*	6620.000	16.184	-53.540	-37.357	-26.357	-11.000	PEAK
2		9930.000	26.318	-66.340	-40.022	-29.022	-11.000	PEAK
3		14895.000	37.324	-76.240	-38.916	-27.916	-11.000	PEAK

Note:

1. All Readings below 1GHz are Quasi-Peak, above 1GHz are performed with peak and/or average measurements as necessary.
2. Peak measurements: RBW = 1MHz, VBW = 1MHz, Sweep: Auto.
3. Average measurements: RBW = 1MHz, VBW = 10 Hz, Sweep: Auto.
4. “ * ”, means this data is the worst emission level.
5. Measurement Level = Reading Level + Correct Factor.
6. The average measurement was not performed when the peak measured data under the limit of average detection.

Site : CB2-H	Time : 2017/04/17
Limit : FCC_90Y_03M_PK	Margin : 6
Probe : CB2_CE_Sub_B091_1-18GHz_3M_0117 - VERTICAL	Power : AC 120V / 60Hz
EUT : Mimosa C5c	Note : 90Y_4965MHz_ Mode 2: Transmit-Dipole

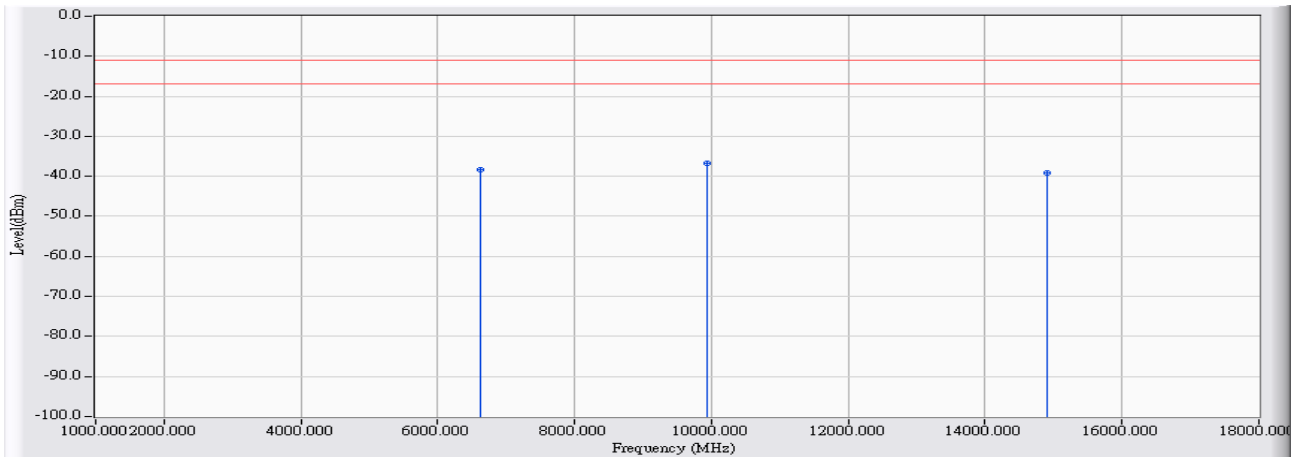

	Frequency (MHz)	Correct Factor (dB)	Reading Level (dBm)	Measure Level (dBm)	Margin (dB)	Limit (dBm)	Detector Type
1	6620.000	15.900	-54.350	-38.450	-27.450	-11.000	PEAK
2	* 9930.000	26.048	-62.740	-36.692	-25.692	-11.000	PEAK
3	14895.000	37.039	-76.130	-39.091	-28.091	-11.000	PEAK

Note:

1. All Readings below 1GHz are Quasi-Peak, above 1GHz are performed with peak and/or average measurements as necessary.
2. Peak measurements: RBW = 1MHz, VBW = 1MHz, Sweep: Auto.
3. Average measurements: RBW = 1MHz, VBW = 10 Hz, Sweep: Auto.
4. “ * ”, means this data is the worst emission level.
5. Measurement Level = Reading Level + Correct Factor.
6. The average measurement was not performed when the peak measured data under the limit of average detection.

Site : CB2-H	Time : 2017/04/17
Limit : FCC_90Y_03M_PK	Margin : 6
Probe : CB2_CE_Sub_B091_1-18GHz_3M_0117 - HORIZONTAL	Power : AC 120V / 60Hz
EUT : Mimoso C5c	Note : 90Y_4980MHz_ Mode 2: Transmit-Dipole

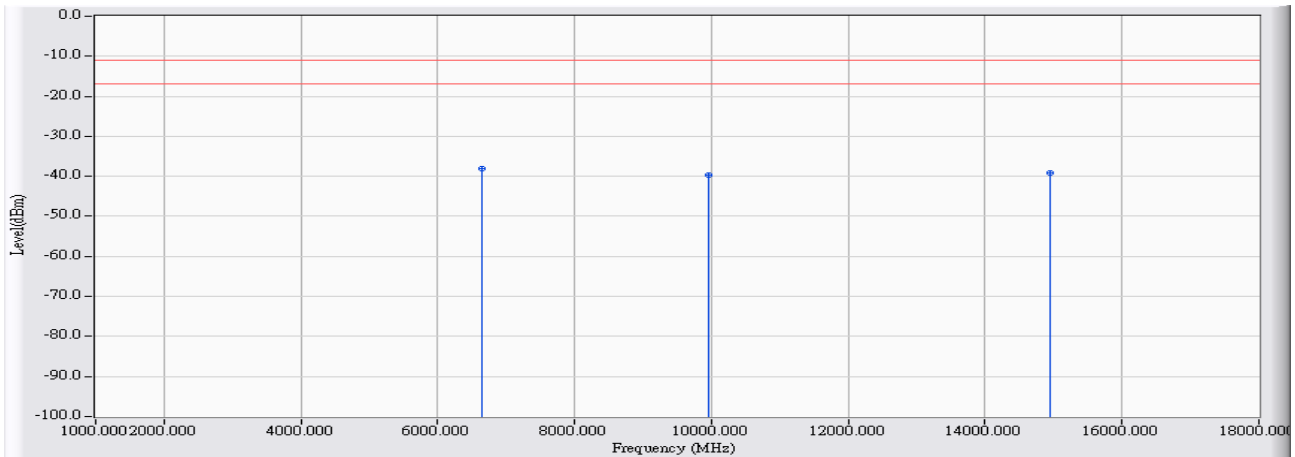

		Frequency (MHz)	Correct Factor (dB)	Reading Level (dBm)	Measure Level (dBm)	Margin (dB)	Limit (dBm)	Detector Type
1	*	6640.000	16.195	-54.250	-38.055	-27.055	-11.000	PEAK
2		9960.000	26.545	-66.190	-39.645	-28.645	-11.000	PEAK
3		14940.000	36.491	-75.740	-39.249	-28.249	-11.000	PEAK

Note:

1. All Readings below 1GHz are Quasi-Peak, above 1GHz are performed with peak and/or average measurements as necessary.
2. Peak measurements: RBW = 1MHz, VBW = 1MHz, Sweep: Auto.
3. Average measurements: RBW = 1MHz, VBW = 10 Hz, Sweep: Auto.
4. “ * ”, means this data is the worst emission level.
5. Measurement Level = Reading Level + Correct Factor.
6. The average measurement was not performed when the peak measured data under the limit of average detection.

Site : CB2-H	Time : 2017/04/17
Limit : FCC_90Y_03M_PK	Margin : 6
Probe : CB2_CE_Sub_B091_1-18GHz_3M_0117 - VERTICAL	Power : AC 120V / 60Hz
EUT : Mimosa C5c	Note : 90Y_4980MHz_ Mode 2: Transmit-Dipole

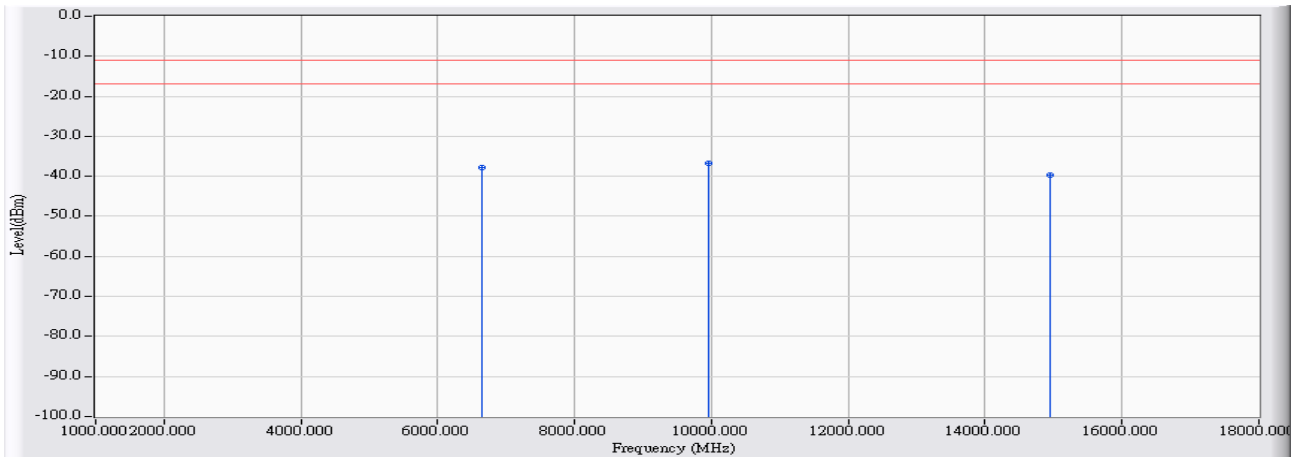

	Frequency (MHz)	Correct Factor (dB)	Reading Level (dBm)	Measure Level (dBm)	Margin (dB)	Limit (dBm)	Detector Type
1	6640.000	15.914	-53.590	-37.676	-26.676	-11.000	PEAK
2	* 9960.000	26.333	-63.140	-36.807	-25.807	-11.000	PEAK
3	14940.000	36.244	-75.890	-39.646	-28.646	-11.000	PEAK

Note:

1. All Readings below 1GHz are Quasi-Peak, above 1GHz are performed with peak and/or average measurements as necessary.
2. Peak measurements: RBW = 1MHz, VBW = 1MHz, Sweep: Auto.
3. Average measurements: RBW = 1MHz, VBW = 10 Hz, Sweep: Auto.
4. “ * ”, means this data is the worst emission level.
5. Measurement Level = Reading Level + Correct Factor.
6. The average measurement was not performed when the peak measured data under the limit of average detection.