

HEARING AID COMPATIBILITY RF EMISSIONS TEST REPORT

FCC ID : 2ABZ2-OP23895
Equipment : Mobile Phone
Brand Name : ONEPLUS, 
Model Name : CPH2655
WD Emission Result : PASS
Applicant : OnePlus Technology (Shenzhen) Co., Ltd.
18C02, 18C03, 18C04, and 18C05, Shum Yip
Terra Building, Binhe Avenue North, Futian
District, Shenzhen, Guangdong, P.R. China.
Manufacturer : OnePlus Technology (Shenzhen) Co., Ltd.
18C02, 18C03, 18C04, and 18C05, Shum Yip
Terra Building, Binhe Avenue North, Futian
District, Shenzhen, Guangdong, P.R. China.
Standard : FCC 47 CFR §20.19
ANSI C63.19-2019
Date Tested : Jun. 30, 2024 ~ Oct. 13, 2024

We, Sporton International Inc. (Shenzhen), would like to declare that the tested sample provide by manufacturer and the test data has been evaluated in accordance with the test procedures given in ANSI C63.19-2019 / 47 CFR Part 20.19 and has been in compliance with the applicable technical standards.

The test results in this report apply exclusively to the tested model / sample. Without written approval of Sporton International Inc. (Shenzhen), the test report shall not be reproduced except in full.



Approved by: Si Zhang

Sporton International Inc. (Shenzhen)

1/F, 2/F, Bldg 5, Shiling Industrial Zone, Xinwei Village, Xili, Nanshan, Shenzhen, 518055
People's Republic of China



Table of Contents

1. General Information 4
2. Testing Location..... 5
3. Applied Standards 5
4. Air Interfaces 6
5. WD Emission Requirements 7
6. System Description and Operation 8
7. RF Emissions Test Procedure..... 11
8. Test Equipment List 13
9. System Validation 14
10. Modulation Interference Factor..... 15
11. Evaluation of WD RF interference potential 16
 11.1 Evaluation RF_{AIPL}..... 16
12. Conducted RF Output Power (Unit: dBm)..... 28
13. RF_{AIL} Test Results 31
14. Uncertainty Assessment 32
15. References..... 33

Appendix A. Plots of System Performance Check
Appendix B. Plots of RF Emission Measurement
Appendix C. DASYS Calibration Certificate
Appendix D. Test Setup Photos
Appendix E. UID specifications for HAC RFE



History of this test report

| Report No. | Version | Description | Issued Date |
|------------|---------|--|---------------|
| HA461101A | Rev. 01 | Initial issue of report | Sep. 27, 2024 |
| HA461101A | Rev. 02 | Added relevant data of n41 UL MIMO. This report is an update version, replacing the report issued on Sep. 27, 2024. | Oct. 14, 2024 |
| | | | |
| | | | |
| | | | |



1. General Information

| Product Feature & Specification | |
|---------------------------------|--|
| Applicant Name | OnePlus Technology (Shenzhen) Co., Ltd. |
| Equipment Name | Mobile Phone |
| Brand Name | ONEPLUS, |
| Model Name | CPH2655 |
| IMEI Code | IMEI 1: 866493070024096 IMEI 2: 866493070024088 |
| FCC ID | 2ABZ2-OP23895 |
| HW | 11 |
| SW | OxygenOS V15.0 |
| EUT Stage | Production Unit |
| Frequency Band | GSM850: 824 MHz ~ 849 MHz GSM1900: 1850MHz ~ 1910MHz WCDMA Band II: 1850 MHz ~ 1910 MHz WCDMA Band IV: 1710 MHz ~ 1755 MHz WCDMA Band V: 824 MHz ~ 849 MHz LTE Band 2: 1850 MHz ~ 1910 MHz LTE Band 4: 1710 MHz ~ 1755 MHz LTE Band 5: 824 MHz ~ 849 MHz LTE Band 7: 2500 MHz ~ 2570 MHz LTE Band 12: 699 MHz ~ 716 MHz LTE Band 13: 777 MHz ~ 787 MHz LTE Band 17: 704 MHz ~ 716 MHz LTE Band 25: 1850 MHz ~ 1915 MHz LTE Band 26: 814 MHz ~ 849 MHz LTE Band 30: 2305 MHz ~ 2315 MHz LTE Band 38: 2570 MHz ~ 2620 MHz LTE Band 41: 2496 MHz ~ 2690 MHz LTE Band 48: 3550 MHz ~ 3700 MHz LTE Band 66: 1710 MHz ~ 1780 MHz LTE Band 71: 663 MHz ~ 698 MHz 5G NR n2 : 1850 MHz ~ 1910 MHz 5G NR n5 : 824 MHz ~ 849 MHz 5G NR n7 : 2500 MHz ~ 2570 MHz 5G NR n12 : 699 MHz ~ 716 MHz 5G NR n25 : 1850 MHz ~ 1915 MHz 5G NR n30 : 2305 MHz ~ 2315 MHz 5G NR n38 : 2570 MHz ~ 2620 MHz 5G NR n41 : 2496 MHz ~ 2690 MHz 5G NR n48 : 3550 MHz ~ 3700 MHz 5G NR n66 : 1710 MHz ~ 1780 MHz 5G NR n71 : 663 MHz ~ 698 MHz 5G NR n77: 3700 MHz ~ 3980 MHz, 3450MHz ~ 3550MHz 5G NR n78: 3700 MHz ~ 3800 MHz, 3450MHz ~ 3550MHz WLAN 2.4GHz Band: 2412 MHz ~ 2462 MHz WLAN 5.2GHz Band: 5180 MHz ~ 5240 MHz WLAN 5.3GHz Band: 5260 MHz ~ 5320 MHz WLAN 5.5GHz Band: 5500 MHz ~ 5700 MHz WLAN 5.8GHz Band: 5745 MHz ~ 5825 MHz WLAN U-NII 5: 5925 MHz ~ 6425 MHz WLAN U-NII 6: 6425 MHz ~ 6525 MHz WLAN U-NII 7: 6525 MHz ~ 6875 MHz WLAN U-NII 8: 6875 MHz ~ 7125 MHz Bluetooth: 2402 MHz ~ 2480 MHz NFC : 13.56 MHz WPT: 110.1KHz ~ 148.5KHz |
| Mode | GSM/GPRS/EGPRS/DTM RMC/AMR 12.2Kbps HSDPA HSUPA DC-HSDPA HSPA+ (16QAM uplink is supported) LTE: QPSK, 16QAM, 64QAM, 256QAM 5G NR: DFT-s-OFDM/CP-OFDM, Pi/2 BPSK/QPSK/16QAM/64QAM/256QAM WLAN 2.4GHz 802.11b/g/n HT20/HT40 |



| | |
|--|---|
| | WLAN 2.4GHz 802.11ac VHT20/VHT40 WLAN 2.4GHz 802.11ax/be HE20/HE40/EHT20/EHT40 WLAN 5GHz 802.11a/n HT20/HT40 WLAN 5GHz 802.11ac VHT20/VHT40/VHT80/VHT160 WLAN 5GHz 802.11ax HE20/HE40/HE80/HE160 WLAN 5GHz 802.11be EHT20/EHT40/EHT80/EHT160 WLAN 6GHz 802.11a/ax HE20/HE40/HE80/HE160 WLAN 6GHz 802.11be EHT20/EHT40/EHT80/EHT160/EHT320 Bluetooth BR/EDR/LE NFC: ASK WPT: ASK |
|--|---|

2. Testing Location

Sporton International Inc. (Shenzhen) is accredited to ISO/IEC 17025:2017 by American Association for Laboratory Accreditation with Certificate Number 5145.01.

| Testing Laboratory | | | |
|--------------------|--|---------------------|--------------------------------|
| Test Firm | Sporton International Inc. (Shenzhen) | | |
| Test Site Location | 1/F, 2/F, Bldg 5, Shiling Industrial Zone, Xinwei Village, Xili, Nanshan, Shenzhen, 518055 People's Republic of China TEL: +86-755-86379589 FAX: +86-755-86379595 | | |
| Test Site No. | Sporton Site No. | FCC Designation No. | FCC Test Firm Registration No. |
| | SAR05-SZ | CN1256 | 421272 |

3. Applied Standards

- FCC CFR47 Part 20.19
- ANSI C63.19-2019
- FCC KDB 285076 D01 HAC Guidance v06r04
- FCC KDB 285076 D03 HAC FAQ v01r06



4. Air Interfaces

| Air Interface | Band MHz | Type | C63.19 RF _{AIRL} Tested | Simultaneous Transmitter | Name of Voice Service | Power State Compliance |
|---------------|----------|-------------------|----------------------------------|---|-----------------------|------------------------|
| GSM | GSM850 | VO | Yes | WLAN, BT | CMRS Voice | Pmax |
| | GSM1900 | | | WLAN, BT | | |
| | EDGE850 | VD | Yes | WLAN, BT | Google Meet | |
| | EDGE1900 | | | WLAN, BT | | |
| WCDMA | Band II | VO | No ⁽¹⁾ | WLAN, BT | CMRS Voice | Pmax |
| | Band IV | | | WLAN, BT | | |
| | Band V | | | WLAN, BT | | |
| | HSPA | VD | No ⁽¹⁾ | WLAN, BT | Google Meet | |
| LTE FDD | Band 2 | VD | No ⁽¹⁾ | 5G NR, WLAN, BT | VoLTE / Google Meet | Pmax |
| | Band 4 | | | 5G NR, WLAN, BT | | |
| | Band 5 | | | 5G NR, WLAN, BT | | |
| | Band 7 | | | 5G NR, WLAN, BT | | |
| | Band 12 | | | 5G NR, WLAN, BT | | |
| | Band 13 | | | 5G NR, WLAN, BT | | |
| | Band 17 | | | 5G NR, WLAN, BT | | |
| | Band 25 | | | 5G NR, WLAN, BT | | |
| | Band 26 | | | 5G NR, WLAN, BT | | |
| | Band 30 | | | 5G NR, WLAN, BT | | |
| | Band 66 | | | 5G NR, WLAN, BT | | |
| | Band 71 | | | 5G NR, WLAN, BT | | |
| | LTE TDD | | | Band 38 | | |
| Band 41 | | 5G NR, WLAN, BT | | | | |
| Band 48 | | VD | No ⁽¹⁾ | 5G NR, WLAN, BT | | |
| 5G NR FDD | n2 | VD | No ⁽¹⁾ | LTE, WLAN, BT | Google Meet | Pmax |
| | n5 | | | LTE, WLAN, BT | | |
| | n7 | | | LTE, WLAN, BT | | |
| | n12 | | | LTE, WLAN, BT | | |
| | n25 | | | LTE, WLAN, BT | | |
| | n30 | | | LTE, WLAN, BT | | |
| | n66 | | | LTE, WLAN, BT | | |
| | n71 | | | LTE, WLAN, BT | | |
| 5G NR TDD | n38 | VD | Yes | LTE, WLAN, BT | | |
| | n41 | | | LTE, WLAN, BT | | |
| | n48 | VD | No ⁽¹⁾ | LTE, WLAN, BT | | |
| | n77 | VD | Yes | LTE, WLAN, BT | | |
| | n78 | | | LTE, WLAN, BT | | |
| Wi-Fi | 2450 | VD | No ⁽¹⁾ | GSM, WCDMA, LTE, 5G NR, 5GHz/6GHz WLAN | VoWiFi / Google Meet | Pmax |
| | 5200 | | | GSM, WCDMA, LTE, 5G NR, 2.4GHz WLAN, BT | | |
| | 5300 | | | GSM, WCDMA, LTE, 5G NR, 2.4GHz WLAN, BT | | |
| | 5500 | | | GSM, WCDMA, LTE, 5G NR, 2.4GHz WLAN, BT | | |
| | 5800 | | | GSM, WCDMA, LTE, 5G NR, 2.4GHz WLAN, BT | | |
| | U-NII 5 | VD | No ⁽³⁾ | GSM, WCDMA, LTE, 5G NR, 2.4GHz WLAN, BT | VoWiFi / Google Meet | Pmax |
| | U-NII 6 | | | | | |
| | U-NII 7 | | | | | |
| U-NII 8 | VD | No ⁽²⁾ | | | | |
| BT | 2450 | DT | No | GSM, WCDMA, LTE, 5G NR, 2.4GHz/5GHz/6GHz WLAN | NA | NA |

Type Transport:
VO= Voice only
DT= Digital Transport only (no voice)
VD= CMRS and IP Voice Service over Digital Transport

- Remark:**
- The air interface max power plus MIF is complies with ANSI C63.19-2019 Table 4.1 RF_{AIRL}
 - WLAN6GHz U-NII 6/7/8 were above 6GHz and were not evaluated due to outside of the current scope of ANSI C63.19 and FCC HAC regulations.
 - The WLAN6GHz U-NII-5 was evaluated for operations which are entirely below 6 GHz, above 6 GHz were not evaluated due outside of the current scope of ANSI C63.19 and FCC HAC regulations.
 - Because features of Google Meet allow the option of voice-only communications, Meet has been tested for HAC/T-coil compatibility to ensure the best user experience.



- 5. The product only 2G/3G/4G/5G/Wi-Fi/BT support time-average SAR feature, therefore GSM/UMTS/LTE/5GFR1/Wi-Fi HAC were tested at Pmax level(the maximum power).
- 6. This device not supported VONR function.
- 7. There are two samples, the difference between them is material of back cover: sample 1 is with leather back cover, Sample 2 is with glass back cover. According to the difference, sample 1 was chosen to perform full testing.

5. WD Emission Requirements

The WD’s conducted power must be at or below either the stated RFAIPL (Table 4.1) or the stated peak power level (Table 4.2), or the average near-field emissions over the measurement area must be at or below the stated RFAIL (Table 4.3), or the stated peak field strength (Table 4.4). The WD may demonstrate compliance by meeting any of these four requirements, but it must do so in each of its operating bands at its established worst-case normal speech-mode operating condition.

| Table 4.1 - Wireless device RF audio interference power level | |
|---|--------------------------|
| Frequency range (MHz) | RF _{AIPL} (dBm) |
| < 960 | 29 |
| 960 - 2000 | 26 |
| > 2000 | 25 |

| Table 4.2 - Wireless device RF peak power level | |
|---|--------------------------------|
| Frequency range (MHz) | RF _{Peak Power} (dBm) |
| < 960 | 35 |
| 960 - 2000 | 32 |
| > 2000 | 31 |

| Table 4.3 - Wireless device RF audio interference level | |
|---|-----------------------------|
| Frequency range (MHz) | RF _{AIL} [dB(V/m)] |
| < 960 | 39 |
| 960 - 2000 | 36 |
| > 2000 | 35 |

| Table 4.4 - Wireless device RF peak near-field level | |
|--|------------------------------|
| Frequency range (MHz) | RF _{Peak} [dB(V/m)] |
| < 960 | 45 |
| 960 - 2000 | 42 |
| > 2000 | 41 |

6. System Description and Operation

<System Components>

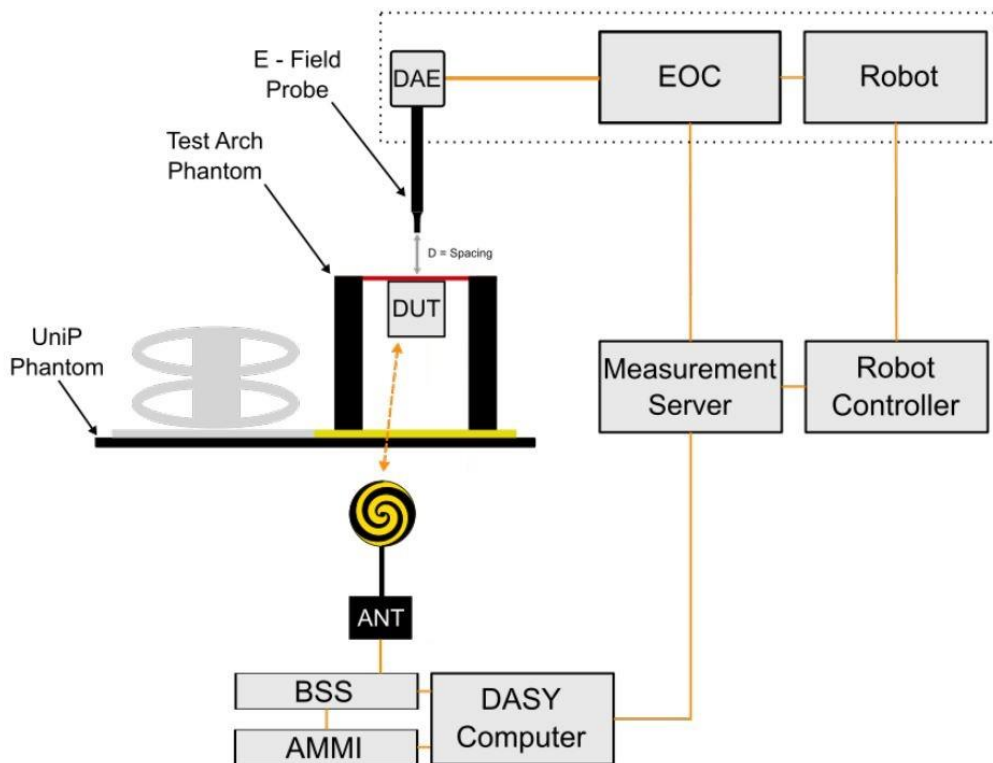

Remark:

A typical al DASy system for HAC measurements consists of

- 6-axis robotic arm (Staubli TX2-60L/ TX2-90XL) for positioning the probe
- Mounting Platform for keeping the phantoms at a field location relative to the robot
- Measurement Server for handling all time-critical tasks, such as measurement data acquisition and supervision of safety features
- EOC (Electrical to Optical Converter) for converting the optical signal from the Data Acquisition Electronics (DAE) to electrical before being transmitted to the measurement server
- LB (Light Beam unit) for probe alignment (measurement of the exact probe length and eccentricity)
- Test Arch for Device Under Test (DUT) testing
- DAE that reads the probe voltages and transmits them to the DASy PC. It is also used to detect probe touch and collision signals
- Device Holder for positioning the DUT beneath the phantom
- ANT (wideband Antenna) for broadcasting the downlink signals emitted by base station simulators (BSS) to the WD
- Operator PC for running the DASy software to define/execute the measurements.

The following components are needed for RFail measurements only:

- Modulation Interference Factor (MIF)
- Isotropic E-field, free-space probe (e.g., EF3DVx)
- Radiofrequency (RF) emission calibration dipoles for system check / validation purposes.

<EF3DV3 E-Field Probe Specification>

| | |
|----------------------|---|
| Construction | One dipole parallel, two dipoles normal to probe axis Interleaved sensors Built-in shielding against static charges PEEK enclosure material |
| Calibration | In air from 30 MHz to 6.0 GHz (absolute accuracy ±5.1%, k=2) |
| Frequency | 30 MHz – 6 GHz Linearity: ±0.2 dB (100 MHz – 3 GHz) |
| Directivity | ± 0.2 dB in air (rotation around probe axis) ± 0.4 dB in air (rotation normal to probe axis) |
| Dynamic Range | 2 – >1000 V/m |
| Linearity | ± 0.2 dB |
| Dimensions | Overall length: 337 mm (tip: 20 mm) Tip diameter: 3.9 mm (body: 12 mm) Distance from probe tip to dipole centers: 1.5 mm Sensor displacement to probe's calibration point: <0.7 mm |

Voltage to E-field Conversion

The measured voltage is first linearized to a quantity proportional to the square of the E-field using the (a, b, c, d) set of parameters specific to the communication system and sensor :

$$V_{comp_i} = U_i + U_i^2 \cdot \frac{10^d}{dcp_i}$$

- where
- V_{comp_i} = compensated signal of channel i (μV) (i = x, y, z)
 - U_i = input signal of channel i (μV) (i = x, y, z)
 - d = PMR factor d (dB) (Probe parameter)
 - dcp_i = diode compression point of channel i (μV) (Probe parameter, i = x, y, z)

$$V_{comp_i \text{ dB}\sqrt{\mu V}} = 10 + \log_{10} (V_{comp_i})$$

$$corr_i = a_i \cdot e - \left(\frac{V_{comp_i \text{ dB}\sqrt{\mu V}} - b_i}{c_i} \right)^2$$

- where
- $corr_i$ = correction factor of channel i (dB) (i = x, y, z)
 - $V_{comp_i \text{ dB}\sqrt{\mu V}}$ = compensated voltage of channel i (dB√μV) (i = x, y, z)
 - a_i = PMR factor a of channel i (dB) (Probe parameter, i = x,y,z)
 - b_i = PMR factor b of channel i (dB√μV) (Probe parameter, i = x,y,z)
 - c_i = PMR factor c of channel i (Probe parameter, i = x,y,z)

The voltage $V_{i \text{ dB}\sqrt{\mu V}}$ is the linearized voltage in dB√μV :

$$V_{i \text{ dB}\sqrt{\mu V}} = V_{comp_i \text{ dB}\sqrt{\mu V}} - corr_i$$

- where
- $V_{i \text{ dB}\sqrt{\mu V}}$ = linearized voltage of channel i (dB√μV) (i = x,y,z)
 - $V_{comp_i \text{ dB}\sqrt{\mu V}}$ = compensated voltage of channel i (dB√μV) (i = x,y,z)
 - $Corr_i$ = correction factor of channel i (dB) (i = x,y,z)

Finally, the linearized voltage is converted in μV :

$$V_i = 10^{\frac{V_{i\text{ dB}\sqrt{\mu\text{V}}}}{10}}$$

where V_i = linearized voltage of channel i (μV) ($i = x, y, z$)
 $V_{i\text{ dB}\sqrt{\mu\text{V}}}$ = linearized voltage of channel i ($\text{dB}\sqrt{\mu\text{V}}$) ($i = x, y, z$)

The E-field data for each channel are calculated using the linearized voltage :

$$\text{E-field Probes : } E_i = \sqrt{\frac{V_i}{\text{Norm}_i \cdot \text{ConvF}}}$$

where V_i = compensated signal of channel i , ($i = x, y, z$)
 Norm_i = sensor sensitivity ($\mu\text{V}/(\text{V/m})^2$) of channel i ($i = x, y, z$)
 ConvF = sensitivity enhancement in solution
 E_i = electric field strength of channel i in V/m

The RMS value of the field components gives the total field strength (Hermitian magnitude) :

$$E_{\text{tot}} = \sqrt{E_x^2 + E_y^2 + E_z^2}$$

Averaged E-field Calculation

The averaged E-field is defined by

$$E_{\text{avg}} = \frac{1}{n} \cdot \sum_{i=1}^n E_i$$

where n = the number of measurement grid point
 E_i = the E-field measured at point i

RFail Calculation

The RFail is finally computed with

$$RFail[\text{dB}(\text{V/m})] = 20 \cdot \log_{10}(E_{\text{avg}}) + MIF$$

where RFail = the Radio Frequency Audio Interference Level in $\text{dB}(\text{V/m})$
 E_{avg} = the averaged E-field in (V/m) calculated
MIF = the Modulation Interference Factor in dB .

7. RF Emissions Test Procedure

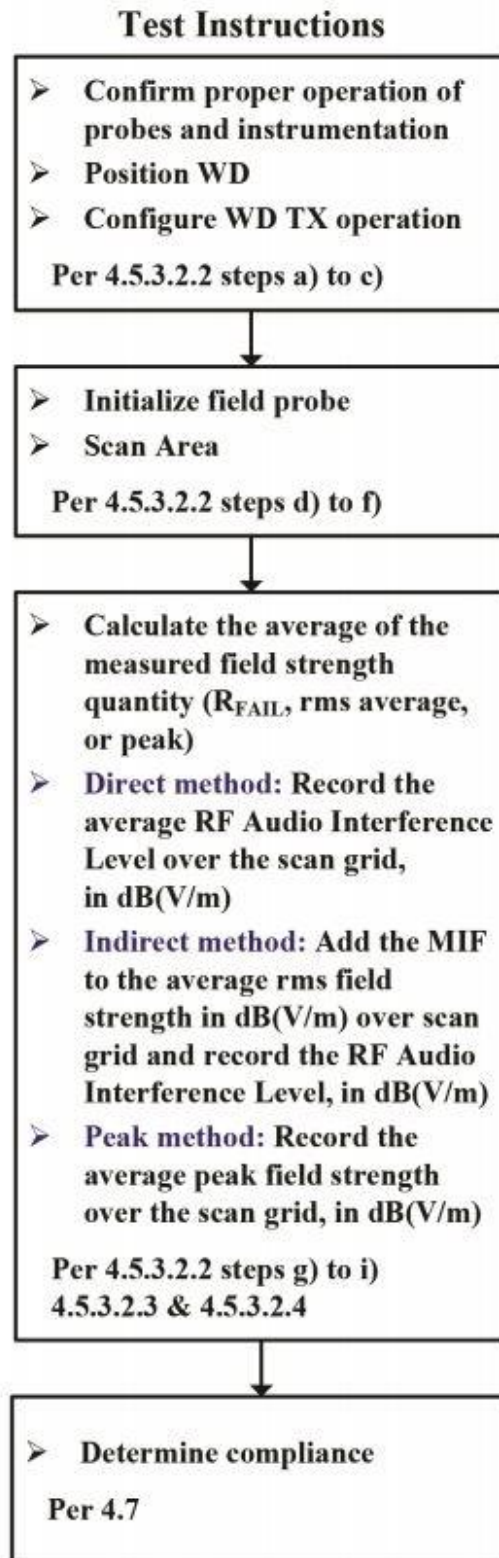
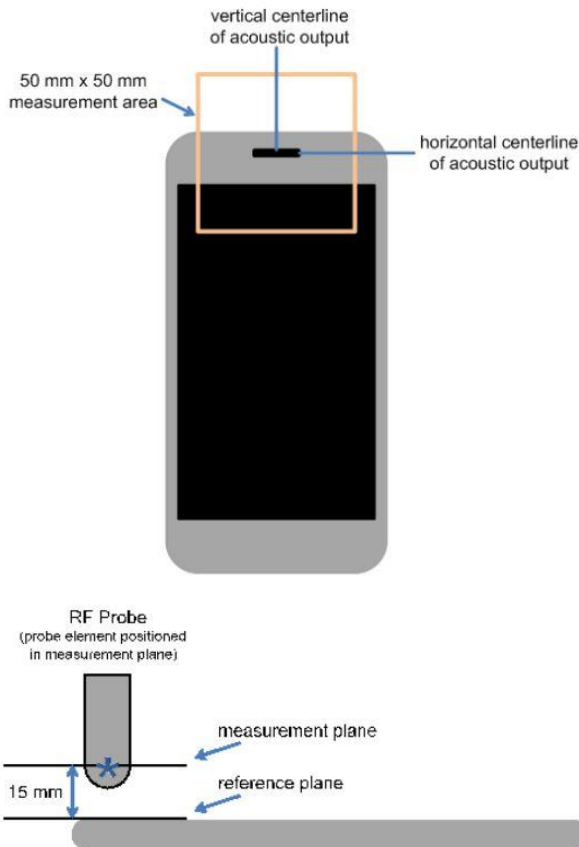
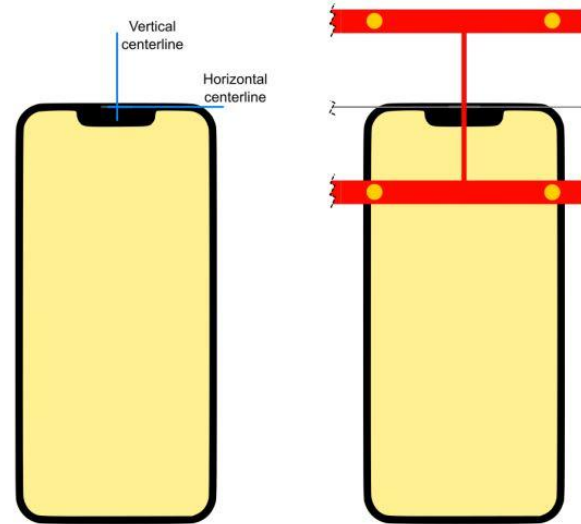

Figure of WD near-field emission scan flowchart according to ANSI C63.19:2019



The references and reference plane that shall be used in the WD emissions measurement



Device Under Test Positioning under the Test Arch

Test procedure: Indirect measurement—preferred

- a. The measurement procedure using a probe and instrumentation chain with a response of <10 kHz (see ANSI C63.19-2019 section 4.5.1) is identical to the direct measurement method of ANSI C63.19-2019 section 4.5.3.2.2: however, because of the bandwidth limitations, it cannot include the direct use of the spectral and temporal weighting functions. The output of such measurement systems must be readings of steady state rms field strength in dB(V/m).
- b. The RF audio interference level in dB(V/m) is obtained by adding the Modulation Interference Factor (in decibels) to the average steady state rms field strength reading over the measurement area, in dB(V/m), from Step c). Use this result to determine the WD's compliance per ANSI C63.19-2019 section 4.7.
- c. Scan the entire 50 mm by 50 mm measurement area in equally spaced step sizes and record the reading at each measurement point. The step size shall meet the specification for step size in ANSI C63.19:2019 section 4.5.3.
- d. Calculate the average of the measurements taken in Step c
- e. Convert the average value found in Step d) to RF audio interference level, in volts per meter, by taking the square root of the reading and then dividing it by the measurement system transfer function, as established in ANSI C63.19:2019 section 4.5.3.2.1 pre-test procedure. Convert the result to dB(V/m) by taking the base-10 logarithm and multiplying it by 20. Expressed as a formula

$$\text{RF audio interference level in dB(V/M)} = 20 * \log(R_{\text{ave}}^{1/2} / \text{TF})$$
 where
 R_{ave} is the average reading
- f. Compare this RF audio interference level to the limits in ANSI C63.19:2019 section 4.7 and record the result
- g. Per ANSI C63.19-2019 section 4.6, WDs capable of operating multiple transmitters shall be subject to emissions requirements for all such transmitters expected to be operated when the WD is in voice mode operation positioned at a user's ear. Each qualified transmitter is tested individually using the method of Clause 4. Other WD transmitters shall be temporarily disabled or reduced in power level such that their average antenna input power is at least 6 dB lower than the average antenna input power of the transmitter under test. The transmitter under test is set to the fixed and repeatable combination of power and modulation characteristic that is representative of the worst case (highest interference potential) likely to be encountered while the WD is experiencing normal voice mode operation. The limiting measurement for device qualification is the highest RF audio interference potential measured for any of the WD transmitters. If the highest interference measurement is from a transmitter that is not required for normal voice mode operation, a secondary rating may be given that applies when that transmitter is disabled



8. Test Equipment List

Table with 6 columns: Manufacturer, Name of Equipment, Type/Model, Serial Number, Last Cal., Due Date. Rows include various equipment like Calibration Dipole, Isotropic E-Field Probe, Radio Communication Analyzer, Power Sensor, etc.

Note:

- 1. NCR: "No-Calibration Required"
2. The dipole calibration interval can be extended to 3 years with justification. The dipoles are also not physically damaged, or repaired during the interval.

9. System Validation

Obtaining accurate measurements and relevant quantities in Module HAC depends on the proper functioning of many components and the correct parameter settings. Faulty results due to drift, failures, or incorrect parameters might not be recognized, as the differences might not be obvious in the measurements. SPEAG DASY incorporates a system check, also called system verification procedure, to test for the proper functioning of the system based on the tests described in ANSI C63.19-2019: the RF interference potential test setup is verified with RF Emission Calibration Dipoles.

<Test Setup>

1. Set the RF signal generator for either CW. Set its output power so the peak power applied to the antenna is equal to that recorded for the real or emulated signal using the WD modulation format
2. Average input power $P = 100 \text{ mW}$ (20 dBm) after adjustment for return loss. An input power that generates field levels similar to those from the WD or other suitable level may also be used
3. The test fixture should meet the two-wavelength separation criterion
4. The probe-to-dipole separation, which is measured from closest surface of the dipole to the center point of the probe sensor element, should be 15 mm

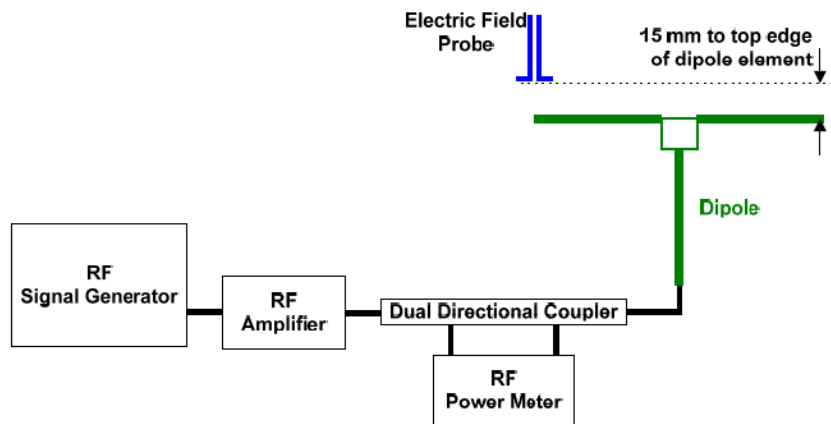

Figure of Setup Diagram

<Validation Procedure>

Place a dipole antenna meeting the requirements given in ANSI C63.19: 2019 D.11 in the position normally occupied by the WD. The dipole antenna serves as a known source for an electrical and magnetic output. Position the E-field probe so that:

- a. The probe and its cable are parallel to the coaxial feed of the dipole antenna
- b. The probe cable and the coaxial feed of the dipole antenna approach the measurement area from opposite directions; and
- c. The center point of the probe element(s) is 15 mm from the closest surface of the dipole elements

Scan the length of the dipole with the E-field probe and record the two maximum values found near the dipole ends. Average the two readings and compare the reading to expected value in the calibration certificate or expected value in this standard.

| Frequency (MHz) | Input Power (dBm) | Target Value (V/m) | E _{max} (V/m) | Deviation (%) | Date |
|-----------------|-------------------|--------------------|------------------------|---------------|---------------|
| 835 | 20 | 107.7 | 109 | 1.21 | Jun. 30, 2024 |
| 1880 | 20 | 85.1 | 86.4 | 1.53 | Jun. 30, 2024 |
| 2600 | 20 | 82.9 | 88.5 | 6.76 | Jun. 30, 2024 |
| 2600 | 20 | 82.9 | 87.7 | 5.79 | Aug. 31, 2024 |
| 3500 | 20 | 84 | 85.6 | 1.90 | Aug. 31, 2024 |
| 2600 | 20 | 82.9 | 87.9 | 6.03 | Oct. 13, 2024 |



10. Modulation Interference Factor

For any specific fixed and repeatable modulated signal, a Modulation Interference Factor (MIF, expressed in decibels) may be developed that relates its interference potential to its steady state rms signal level or average power level. This factor is a function only of the audio frequency amplitude modulation characteristics of the signal and is the same for field strength or conducted power measurements. It is important to emphasize that the MIF is valid only for a specific repeatable audio frequency amplitude modulation characteristic. Any change in modulation characteristic requires determination and application of a new MIF.

MIF may be determined using a radiated RF field, a conducted RF signal, or, in a preliminary stage, a mathematical analysis of a modeled RF signal.

- a. Verify the slope accuracy and dynamic range capability over the desired operating frequency band of a fast probe or sensor, square-law detector, as specified in ANSI C63.19: 2019 D.3, and weighting system as specified in ANSI C63.19: 2019 D.4 and ANSI C63.19: 2019 D.5. For the probe and instrumentation included in the measurement of MIF, additional calibration and application of calibration factors are not required.
b. Using RF illumination, or conducted coupling, apply the specific modulated signal in question to the measurement system at a level within its confirmed operating dynamic range
c. Measure the steady-state rms level at the output of the fast probe or sensor
d. Measure the steady-state average level at the weighting output
e. Without changing the square-law detector or weighting system, and using RF illumination, or conducted coupling, substitute for the specific modulated signal a 1 kHz, 80% amplitude modulated carrier at the same frequency and adjust its strength until the level at the weighting output equals the Step d) measurement
f. Without changing the carrier level from Step e), remove the 1 kHz modulation and again measure the steady-state rms level indicated at the output of the fast probe or sensor.
g. The MIF for the specific modulation characteristic is given by the ratio of the Step f) measurement to the Step c) measurement, expressed in decibels (20*log(step6/step3))

In practice, Step e) and Step f) need not be repeated for each MIF determination if the relationship between the two measurements has been pre-established for the measurement system over the operating frequency and dynamic ranges. In such cases, only the modulation characteristic being tested needs to be available during WD testing. Since indirect measurement procedure was using for RF audio interference power level evaluation, the MIF values applied in this test report were provided by the HAC equipment provider of SPEAG, and the worst values for all air interface are listed below to be determine the Wireless device RF audio interference power level.

Table with 3 columns: UID, Communication System Name, MIF(dB). Rows include GSM-FDD, EDGE-FDD, UMTS-FDD, LTE-FDD, LTE-TDD, 5G NR, and various IEEE WiFi standards.



11. Evaluation of WD RF interference potential

General Note:

1. In this report, max conducted power from each air interface was first used to evaluate whether it complies with ANSI C63.19-2019 Table 4.1 RF_{A IPL}, compliance with table 4.1 means compliance with WD emission requirements. the RF_{A IPL} evaluation refer to section 11.1 for detail.
2. If there some air interface were not meet ANSI C63.19-2019 table 4.1 requirement, these air interfaces were further evaluation ANSI C63.19-2019 Table 4.3 RFAIL requirement. And the RFAIL evaluation result refer to section 13.

11.1 Evaluation RF_{A IPL}

<WWAN Max Tune-up Limit>

<Ant0>

| Frequency Band | | Average Power (dBm) |
|----------------|-------------|---------------------|
| WCDMA | Band V | 24.80 |
| | HSPA | 21.80 |
| | Band IV | 24.80 |
| | HSPA | 21.80 |
| | Band II | 24.80 |
| | HSPA | 21.80 |
| LTE FDD | Band 2 | 24.80 |
| | Band 4 | 24.80 |
| | Band 5 | 24.80 |
| | Band 7 | 23.80 |
| | Band 12 | 24.80 |
| | Band 13 | 24.30 |
| | Band 17 | 24.80 |
| | Band 25 | 24.80 |
| | Band 26 | 24.80 |
| | Band 30 | 23.80 |
| | Band 66 | 24.80 |
| | Band 71 | 24.00 |
| LTE TDD | Band 38 | 24.80 |
| | Band 41-PC3 | 23.80 |
| | Band 41-PC2 | 26.30 |
| NR FDD | FR1 n2 | 25.20 |
| | FR1 n5 | 25.20 |
| | FR1 n7 | 24.20 |
| | FR1 n12 | 25.20 |
| | FR1 n25 | 25.20 |
| | FR1 n30 | 24.20 |
| | FR1 n66 | 25.20 |
| | FR1 n71 | 24.40 |
| NR TDD | FR1 n38 | 25.20 |
| | FR1 n41-PC3 | 24.20 |
| | FR1 n41-PC2 | 26.70 |



<Ant1>

| Frequency Band | | Average Power (dBm) |
|----------------|---------|---------------------|
| GSM | GSM850 | 34.00 |
| | EDGE850 | 28.00 |
| WCDMA | Band V | 24.80 |
| | HSPA | 21.80 |
| LTE FDD | Band 5 | 25.00 |
| | Band 12 | 25.00 |
| | Band 13 | 24.80 |
| | Band 17 | 25.00 |
| | Band 26 | 25.00 |
| NR FDD | Band 71 | 24.80 |
| | FR1 n5 | 25.40 |
| | FR1 n12 | 25.40 |
| | FR1 n71 | 25.20 |

<Ant5>

| Frequency Band | | Average Power (dBm) |
|----------------|-------------|---------------------|
| GSM | GSM1900 | 31.50 |
| | EDGE1900 | 27.00 |
| WCDMA | Band IV | 25.00 |
| | HSPA | 22.00 |
| | Band II | 25.00 |
| | HSPA | 22.00 |
| LTE FDD | Band 2 | 25.00 |
| | Band 4 | 24.80 |
| | Band 7 | 24.30 |
| | Band 25 | 25.00 |
| | Band 30 | 24.80 |
| LTE TDD | Band 66 | 25.00 |
| | Band 38 | 25.00 |
| | Band 41-PC3 | 24.80 |
| NR FDD | Band 41-PC2 | 27.30 |
| | FR1 n2 | 25.40 |
| | FR1 n7 | 24.70 |
| | FR1 n25 | 25.40 |
| | FR1 n30 | 25.20 |
| NR TDD | FR1 n66 | 25.40 |
| | FR1 n38 | 25.40 |
| | FR1 n41-PC3 | 25.20 |
| | FR1 n41-PC2 | 27.70 |



<Ant6>

| Frequency Band | | Average Power (dBm) |
|----------------|-------------|---------------------|
| LTE FDD | Band 2 | 24.00 |
| | Band 4 | 23.80 |
| | Band 7 | 23.80 |
| | Band 25 | 24.00 |
| | Band 30 | 23.80 |
| | Band 66 | 24.80 |
| LTE TDD | Band 38 | 24.80 |
| | Band 41-PC3 | 24.80 |
| | Band 41-PC2 | 26.80 |
| | Band 48 | 24.30 |
| NR FDD | FR1 n2 | 24.70 |
| | FR1 n7 | 24.20 |
| | FR1 n25 | 24.40 |
| | FR1 n66 | 25.20 |
| NR TDD | FR1 n38 | 25.20 |
| | FR1 n41-PC3 | 24.20 |
| | FR1 n41-PC2 | 26.70 |
| | FR1 n48 | 24.70 |
| | FR1 n77-PC3 | 24.70 |
| | FR1 n77-PC2 | 26.70 |
| | FR1 n78-PC3 | 24.70 |
| | FR1 n78-PC2 | 26.70 |

<Ant7>

| Frequency Band | | Average Power (dBm) |
|----------------|-------------|---------------------|
| LTE FDD | Band 2 | 24.80 |
| | Band 4 | 23.80 |
| | Band 7 | 23.80 |
| | Band 25 | 24.80 |
| | Band 30 | 24.30 |
| | Band 66 | 25.00 |
| LTE TDD | Band 38 | 25.00 |
| | Band 41-PC3 | 24.80 |
| | Band 41-PC2 | 26.80 |
| NR FDD | FR1 n2 | 25.20 |
| | FR1 n7 | 24.20 |
| | FR1 n25 | 25.20 |
| | FR1 n66 | 25.40 |
| NR TDD | FR1 n38 | 25.40 |
| | FR1 n41-PC3 | 24.70 |
| | FR1 n41-PC2 | 27.20 |

<Ant10>

| Frequency Band | | Average Power (dBm) |
|----------------|-------------|---------------------|
| LTE TDD | Band 48 | 24.80 |
| NR TDD | FR1 n48 | 25.20 |
| | FR1 n77-PC3 | 25.20 |
| | FR1 n77-PC2 | 27.20 |
| | FR1 n78-PC3 | 25.20 |
| | FR1 n78-PC2 | 27.20 |



<Ant11>

| Frequency Band | | Average Power (dBm) |
|----------------|-------------|---------------------|
| LTE TDD | Band 48 | 24.80 |
| NR TDD | FR1 n48 | 25.20 |
| | FR1 n77-PC3 | 25.20 |
| | FR1 n77-PC2 | 26.50 |
| | FR1 n78-PC3 | 25.20 |
| | FR1 n78-PC2 | 26.50 |

<Ant12>

| Frequency Band | | Average Power (dBm) |
|----------------|-------------|---------------------|
| LTE TDD | Band 48 | 23.30 |
| NR TDD | FR1 n48 | 23.70 |
| | FR1 n77-PC3 | 24.20 |
| | FR1 n77-PC2 | 26.20 |
| | FR1 n78-PC3 | 24.20 |
| | FR1 n78-PC2 | 26.20 |

<UL MIMO>

| Frequency Band | | Average Power (dBm) |
|---------------------|-----------------|---------------------|
| N41 UL-MIMO Ant 5+7 | FR1 n41-UL-MIMO | 30.50 |
| N41 UL-MIMO Ant 0+6 | FR1 n41-UL-MIMO | 29.50 |

<WLAN Max Tune-up Limit>

| Frequency Band | | Average Power (dBm) |
|-----------------------|-----------------|---------------------|
| 2.4GHz WLAN Ant 13 | 802.11b | 22.50 |
| | 802.11g | 22.50 |
| | 802.11n-HT20 | 22.50 |
| | 802.11n-HT40 | 22.50 |
| | 802.11ac-VHT20 | 22.50 |
| | 802.11ac-VHT40 | 22.50 |
| | 802.11ax-HE20 | 22.00 |
| | 802.11ax-HE40 | 22.00 |
| | 802.11be-EHT20 | 18.50 |
| | 802.11be-EHT40 | 17.50 |
| 5GHz WLAN Ant 14 | 802.11a | 23.00 |
| | 802.11n-HT20 | 23.00 |
| | 802.11n-HT40 | 22.50 |
| | 802.11ac-VHT20 | 23.00 |
| | 802.11ac-VHT40 | 22.50 |
| | 802.11ac-VHT80 | 22.50 |
| | 802.11ac-VHT160 | 18.50 |
| | 802.11ax-HE20 | 22.50 |
| | 802.11ax-HE40 | 22.50 |
| | 802.11ax-HE80 | 21.50 |
| | 802.11ax-HE160 | 18.50 |
| | 802.11be-EHT20 | 19.50 |
| | 802.11be-EHT40 | 19.50 |
| | 802.11be-EHT80 | 19.50 |
| 802.11be-EHT160 | 18.50 | |
| 6GHz WLAN Ant 14 | 802.11a | 7.00 |
| | 802.11ax-HE20 | 6.00 |
| | 802.11ax-HE40 | 11.50 |



| | | |
|--|----------------|-------|
| | 802.11be-EHT20 | 6.00 |
| | 802.11be-EHT40 | 11.50 |

| Frequency Band | | Average Power (dBm) |
|-----------------------|-----------------|---------------------|
| 2.4GHz WLAN Ant 10 | 802.11b | 22.50 |
| | 802.11g | 22.50 |
| | 802.11n-HT20 | 22.50 |
| | 802.11n-HT40 | 22.50 |
| | 802.11ac-VHT20 | 22.50 |
| | 802.11ac-VHT40 | 22.50 |
| | 802.11ax-HE20 | 22.00 |
| | 802.11ax-HE40 | 22.00 |
| | 802.11be-EHT20 | 18.50 |
| 802.11be-EHT40 | 17.50 | |
| 5GHz WLAN Ant 15 | 802.11a | 23.00 |
| | 802.11n-HT20 | 23.00 |
| | 802.11n-HT40 | 22.50 |
| | 802.11ac-VHT20 | 23.00 |
| | 802.11ac-VHT40 | 22.50 |
| | 802.11ac-VHT80 | 22.50 |
| | 802.11ac-VHT160 | 18.50 |
| | 802.11ax-HE20 | 22.50 |
| | 802.11ax-HE40 | 21.50 |
| | 802.11ax-HE80 | 21.00 |
| | 802.11ax-HE160 | 18.50 |
| | 802.11be-EHT20 | 19.50 |
| | 802.11be-EHT40 | 19.50 |
| 802.11be-EHT80 | 19.50 | |
| 802.11be-EHT160 | 18.50 | |
| 6GHz WLAN Ant 15 | 802.11a | 7.50 |
| | 802.11ax-HE20 | 7.50 |
| | 802.11ax-HE40 | 11.00 |
| | 802.11be-EHT20 | 7.50 |
| | 802.11be-EHT40 | 11.00 |

| Frequency Band | | Average Power (dBm) |
|--------------------------|-----------------|---------------------|
| 2.4GHz WLAN Ant 13+10 | 802.11b | 25.50 |
| | 802.11g | 22.00 |
| | 802.11n-HT20 | 22.00 |
| | 802.11n-HT40 | 21.00 |
| | 802.11ac-VHT20 | 22.00 |
| | 802.11ac-VHT40 | 21.00 |
| | 802.11ax-HE20 | 21.50 |
| | 802.11ax-HE40 | 20.80 |
| | 802.11be-EHT20 | 21.50 |
| 802.11be-EHT40 | 20.50 | |
| 5GHz WLAN Ant 14+15 | 802.11a | 23.00 |
| | 802.11n-HT20 | 23.00 |
| | 802.11n-HT40 | 23.00 |
| | 802.11ac-VHT20 | 23.00 |
| | 802.11ac-VHT40 | 23.00 |
| | 802.11ac-VHT80 | 23.00 |
| | 802.11ac-VHT160 | 21.50 |
| | 802.11ax-HE20 | 22.50 |



| | | |
|------------------------|-----------------|-------|
| | 802.11ax-HE40 | 22.50 |
| | 802.11ax-HE80 | 22.50 |
| | 802.11ax-HE160 | 21.50 |
| | 802.11be-EHT20 | 22.50 |
| | 802.11be-EHT40 | 22.50 |
| | 802.11be-EHT80 | 22.50 |
| | 802.11be-EHT160 | 21.50 |
| 6GHz WLAN Ant 14+15 | 802.11a | 10.00 |
| | 802.11ax-HE20 | 10.00 |
| | 802.11ax-HE40 | 14.50 |
| | 802.11be-EHT20 | 10.00 |
| | 802.11be-EHT40 | 14.50 |

<Evaluation RF audio interference power level>

General Note:

1. Use maximum power plus worst case MIF to determine whether it complies with RF_{AIPL}.
2. If maximum power plus worst case MIF does not complies with RF_{AIPL}, then further evaluation RF_{AIL} include in section 13.
3. EDGE data modes is not necessary due the GSM Voice mode is the worst case.
4. According to ANSI C63.19 2019, if maximum power plus worst case MIF is complies with RF_{AIPL}, means compliance with WD emission requirements.

<Ant0>

| Frequency Band | | Average Power (dBm) | Worst Case MIF (dB) | Power + MIF (dBm) | C63.19 Lowest RF _{AIPL} (dBm) | C63.19 RF _{AIL} Test Required |
|----------------|-------------|---------------------|---------------------|-------------------|--|--|
| WCDMA | Band V | 24.80 | -25.43 | -0.63 | 29 | NO |
| | HSPA | 21.80 | -20.39 | 1.41 | 29 | NO |
| | Band IV | 24.80 | -25.43 | -0.63 | 26 | NO |
| | HSPA | 21.80 | -20.39 | 1.41 | 26 | NO |
| | Band II | 24.80 | -25.43 | -0.63 | 26 | NO |
| | HSPA | 21.80 | -20.39 | 1.41 | 26 | NO |
| LTE FDD | Band 2 | 24.80 | -9.76 | 15.04 | 26 | NO |
| | Band 4 | 24.80 | -9.76 | 15.04 | 26 | NO |
| | Band 5 | 24.80 | -9.76 | 15.04 | 29 | NO |
| | Band 7 | 23.80 | -9.76 | 14.04 | 25 | NO |
| | Band 12 | 24.80 | -9.76 | 15.04 | 29 | NO |
| | Band 13 | 24.30 | -9.76 | 14.54 | 29 | NO |
| | Band 17 | 24.80 | -9.76 | 15.04 | 29 | NO |
| | Band 25 | 24.80 | -9.76 | 15.04 | 26 | NO |
| | Band 26 | 24.80 | -9.76 | 15.04 | 29 | NO |
| | Band 30 | 23.80 | -9.76 | 14.04 | 25 | NO |
| | Band 66 | 24.80 | -9.76 | 15.04 | 26 | NO |
| LTE TDD | Band 71 | 24.00 | -9.76 | 14.24 | 29 | NO |
| | Band 38 | 24.80 | -1.44 | 23.36 | 25 | NO |
| | Band 41-PC3 | 23.80 | -1.44 | 22.36 | 25 | NO |
| | Band 41-PC2 | 26.30 | -1.44 | 24.86 | 25 | NO |
| NR FDD | FR1 n2 | 25.20 | -12.08 | 13.12 | 26 | NO |
| | FR1 n5 | 25.20 | -12.08 | 13.12 | 29 | NO |
| | FR1 n7 | 24.20 | -12.08 | 12.12 | 25 | NO |
| | FR1 n12 | 25.20 | -12.08 | 13.12 | 29 | NO |
| | FR1 n25 | 25.20 | -12.08 | 13.12 | 26 | NO |
| | FR1 n30 | 24.20 | -12.08 | 12.12 | 25 | NO |
| | FR1 n66 | 25.20 | -12.08 | 13.12 | 26 | NO |
| NR TDD | FR1 n71 | 24.40 | -12.08 | 12.32 | 29 | NO |
| FR1 n38 | 25.20 | -1.64 | 23.56 | 25 | NO | |



| | | | | | | |
|--|-------------|-------|-------|-------|----|-----|
| | FR1 n41-PC3 | 24.20 | -1.64 | 22.56 | 25 | NO |
| | FR1 n41-PC2 | 26.70 | -1.64 | 25.06 | 25 | Yes |

<Ant1>

| Frequency Band | | Average Power (dBm) | Worst Case MIF (dB) | Power + MIF (dBm) | C63.19 Lowest RF _{A1PL} (dBm) | C63.19 RF _{AIL} Test Required |
|----------------|---------|---------------------|---------------------|-------------------|--|--|
| GSM | GSM850 | 34.00 | 3.63 | 37.63 | 29 | Yes |
| | EDGE850 | 28.00 | 3.75 | 31.75 | 29 | NO ⁽³⁾ |
| WCDMA | Band V | 24.80 | -25.43 | -0.63 | 29 | NO |
| | HSPA | 21.80 | -20.39 | 1.41 | 29 | NO |
| LTE FDD | Band 5 | 25.00 | -9.76 | 15.24 | 29 | NO |
| | Band 12 | 25.00 | -9.76 | 15.24 | 29 | NO |
| | Band 13 | 24.80 | -9.76 | 15.04 | 29 | NO |
| | Band 17 | 25.00 | -9.76 | 15.24 | 29 | NO |
| | Band 26 | 25.00 | -9.76 | 15.24 | 29 | NO |
| NR FDD | Band 71 | 24.80 | -9.76 | 15.04 | 29 | NO |
| | FR1 n5 | 25.40 | -12.08 | 13.32 | 29 | NO |
| | FR1 n12 | 25.40 | -12.08 | 13.32 | 29 | NO |
| | FR1 n71 | 25.20 | -12.08 | 13.12 | 29 | NO |

<Ant5>

| Frequency Band | | Average Power (dBm) | Worst Case MIF (dB) | Power + MIF (dBm) | C63.19 Lowest RF _{A1PL} (dBm) | C63.19 RF _{AIL} Test Required |
|----------------|-------------|---------------------|---------------------|-------------------|--|--|
| GSM | GSM1900 | 31.50 | 3.63 | 35.13 | 26 | Yes |
| | EDGE1900 | 27.00 | 3.75 | 30.75 | 26 | NO ⁽³⁾ |
| WCDMA | Band IV | 25.00 | -25.43 | -0.43 | 26 | NO |
| | HSPA | 22.00 | -20.39 | 1.61 | 26 | NO |
| | Band II | 25.00 | -25.43 | -0.43 | 26 | NO |
| LTE FDD | HSPA | 22.00 | -20.39 | 1.61 | 26 | NO |
| | Band 2 | 25.00 | -9.76 | 15.24 | 26 | NO |
| | Band 4 | 24.80 | -9.76 | 15.04 | 26 | NO |
| | Band 7 | 24.30 | -9.76 | 14.54 | 25 | NO |
| | Band 25 | 25.00 | -9.76 | 15.24 | 26 | NO |
| | Band 30 | 24.80 | -9.76 | 15.04 | 25 | NO |
| LTE TDD | Band 66 | 25.00 | -9.76 | 15.24 | 26 | NO |
| | Band 38 | 25.00 | -1.44 | 23.56 | 25 | NO |
| | Band 41-PC3 | 24.80 | -1.44 | 23.36 | 25 | NO |
| NR FDD | Band 41-PC2 | 27.30 | -1.44 | 25.86 | 25 | Yes |
| | FR1 n2 | 25.40 | -12.08 | 13.32 | 26 | NO |
| | FR1 n7 | 24.70 | -12.08 | 12.62 | 25 | NO |
| | FR1 n25 | 25.40 | -12.08 | 13.32 | 26 | NO |
| | FR1 n30 | 25.20 | -12.08 | 13.12 | 25 | NO |
| NR TDD | FR1 n66 | 25.40 | -12.08 | 13.32 | 26 | NO |
| | FR1 n38 | 25.40 | -1.64 | 23.76 | 25 | NO |
| | FR1 n41-PC3 | 25.20 | -1.64 | 23.56 | 25 | NO |
| | FR1 n41-PC2 | 27.70 | -1.64 | 26.06 | 25 | Yes |



<Ant6>

| Frequency Band | | Average Power (dBm) | Worst Case MIF (dB) | Power + MIF (dBm) | C63.19 Lowest RF _{A1PL} (dBm) | C63.19 RF _{AIL} Test Required |
|----------------|-------------|---------------------|---------------------|-------------------|--|--|
| LTE FDD | Band 2 | 24.00 | -9.76 | 14.24 | 26 | NO |
| | Band 4 | 23.80 | -9.76 | 14.04 | 26 | NO |
| | Band 7 | 23.80 | -9.76 | 14.04 | 25 | NO |
| | Band 25 | 24.00 | -9.76 | 14.24 | 26 | NO |
| | Band 30 | 23.80 | -9.76 | 14.04 | 25 | NO |
| | Band 66 | 24.80 | -9.76 | 15.04 | 26 | NO |
| LTE TDD | Band 38 | 24.80 | -1.44 | 23.36 | 25 | NO |
| | Band 41-PC3 | 24.80 | -1.44 | 23.36 | 25 | NO |
| | Band 41-PC2 | 26.80 | -1.44 | 25.36 | 25 | Yes |
| | Band 48 | 24.30 | -1.44 | 22.86 | 25 | NO |
| NR FDD | FR1 n2 | 24.70 | -12.08 | 12.62 | 26 | NO |
| | FR1 n7 | 24.20 | -12.08 | 12.12 | 25 | NO |
| | FR1 n25 | 24.40 | -12.08 | 12.32 | 26 | NO |
| | FR1 n66 | 25.20 | -12.08 | 13.12 | 26 | NO |
| NR TDD | FR1 n38 | 25.20 | -1.64 | 23.56 | 25 | NO |
| | FR1 n41-PC3 | 24.20 | -1.64 | 22.56 | 25 | NO |
| | FR1 n41-PC2 | 26.70 | -1.64 | 25.06 | 25 | Yes |
| | FR1 n48 | 24.70 | -1.64 | 23.06 | 25 | NO |
| | FR1 n77-PC3 | 24.70 | -1.64 | 23.06 | 25 | NO |
| | FR1 n77-PC2 | 26.70 | -1.64 | 25.06 | 25 | Yes |
| | FR1 n78-PC3 | 24.70 | -1.64 | 23.06 | 25 | NO |
| | FR1 n78-PC2 | 26.70 | -1.64 | 25.06 | 25 | Yes |

<Ant7>

| Frequency Band | | Average Power (dBm) | Worst Case MIF (dB) | Power + MIF (dBm) | C63.19 Lowest RF _{A1PL} (dBm) | C63.19 RF _{AIL} Test Required |
|----------------|-------------|---------------------|---------------------|-------------------|--|--|
| LTE FDD | Band 2 | 24.80 | -9.76 | 15.04 | 26 | NO |
| | Band 4 | 23.80 | -9.76 | 14.04 | 26 | NO |
| | Band 7 | 23.80 | -9.76 | 14.04 | 25 | NO |
| | Band 25 | 24.80 | -9.76 | 15.04 | 26 | NO |
| | Band 30 | 24.30 | -9.76 | 14.54 | 25 | NO |
| | Band 66 | 25.00 | -9.76 | 15.24 | 26 | NO |
| LTE TDD | Band 38 | 25.00 | -1.44 | 23.56 | 25 | NO |
| | Band 41-PC3 | 24.80 | -1.44 | 23.36 | 25 | NO |
| | Band 41-PC2 | 26.80 | -1.44 | 25.36 | 25 | Yes |
| NR FDD | FR1 n2 | 25.20 | -12.08 | 13.12 | 26 | NO |
| | FR1 n7 | 24.20 | -12.08 | 12.12 | 25 | NO |
| | FR1 n25 | 25.20 | -12.08 | 13.12 | 26 | NO |
| | FR1 n66 | 25.40 | -12.08 | 13.32 | 26 | NO |
| NR TDD | FR1 n38 | 25.40 | -1.64 | 23.76 | 25 | NO |
| | FR1 n41-PC3 | 24.70 | -1.64 | 23.06 | 25 | NO |
| | FR1 n41-PC2 | 27.20 | -1.64 | 25.56 | 25 | Yes |



<Ant10>

| Frequency Band | | Average Power (dBm) | Worst Case MIF (dB) | Power + MIF (dBm) | C63.19 Lowest RF _{AIPL} (dBm) | C63.19 RF _{AIL} Test Required |
|----------------|-------------|---------------------|---------------------|-------------------|--|--|
| LTE TDD | Band 48 | 24.80 | -1.44 | 23.36 | 25 | NO |
| NR TDD | FR1 n48 | 25.20 | -1.64 | 23.56 | 25 | NO |
| | FR1 n77-PC3 | 25.20 | -1.64 | 23.56 | 25 | NO |
| | FR1 n77-PC2 | 27.20 | -1.64 | 25.56 | 25 | Yes |
| | FR1 n78-PC3 | 25.20 | -1.64 | 23.56 | 25 | NO |
| | FR1 n78-PC2 | 27.20 | -1.64 | 25.56 | 25 | Yes |

<Ant11>

| Frequency Band | | Average Power (dBm) | Worst Case MIF (dB) | Power + MIF (dBm) | C63.19 Lowest RF _{AIPL} (dBm) | C63.19 RF _{AIL} Test Required |
|----------------|-------------|---------------------|---------------------|-------------------|--|--|
| LTE TDD | Band 48 | 24.80 | -1.44 | 23.36 | 25 | NO |
| NR TDD | FR1 n48 | 25.20 | -1.64 | 23.56 | 25 | NO |
| | FR1 n77-PC3 | 25.20 | -1.64 | 23.56 | 25 | NO |
| | FR1 n77-PC2 | 26.50 | -1.64 | 24.86 | 25 | NO |
| | FR1 n78-PC3 | 25.20 | -1.64 | 23.56 | 25 | NO |
| | FR1 n78-PC2 | 26.50 | -1.64 | 24.86 | 25 | NO |

<Ant12>

| Frequency Band | | Average Power (dBm) | Worst Case MIF (dB) | Power + MIF (dBm) | C63.19 Lowest RF _{AIPL} (dBm) | C63.19 RF _{AIL} Test Required |
|----------------|-------------|---------------------|---------------------|-------------------|--|--|
| LTE TDD | Band 48 | 23.30 | -1.44 | 21.86 | 25 | NO |
| NR TDD | FR1 n48 | 23.70 | -1.64 | 22.06 | 25 | NO |
| | FR1 n77-PC3 | 24.20 | -1.64 | 22.56 | 25 | NO |
| | FR1 n77-PC2 | 26.20 | -1.64 | 24.56 | 25 | NO |
| | FR1 n78-PC3 | 24.20 | -1.64 | 22.56 | 25 | NO |
| | FR1 n78-PC2 | 26.20 | -1.64 | 24.56 | 25 | NO |

<UL MIMO>

| Frequency Band | | Average Power (dBm) | Worst Case MIF (dB) | Power + MIF (dB) | C63.19 Lowest RF _{AIPL} (dBm) | C63.19 RF _{AIL} Test Required |
|---------------------|-----------------|---------------------|---------------------|------------------|--|--|
| N41 UL-MIMO Ant 5+7 | FR1 n41-UL-MIMO | 30.50 | -1.64 | 28.86 | 25 | Yes |
| N41 UL-MIMO Ant 0+6 | FR1 n41-UL-MIMO | 29.50 | -1.64 | 27.86 | 25 | Yes |



<WLAN Ant>

| Frequency Band | | Average Power (dBm) | Worst Case MIF (dB) | Power + MIF (dBm) | C63.19 Lowest RF _{AIPL} (dBm) | C63.19 RF _{AIL} Test Required |
|-----------------------|-----------------|---------------------|---------------------|-------------------|--|--|
| 2.4GHz WLAN Ant 13 | 802.11b | 22.50 | -2.02 | 20.48 | 25 | NO |
| | 802.11g | 22.50 | 0.12 | 22.62 | 25 | NO |
| | 802.11n-HT20 | 22.50 | -13.44 | 9.06 | 25 | NO |
| | 802.11n-HT40 | 22.50 | -13.44 | 9.06 | 25 | NO |
| | 802.11ac-VHT20 | 22.50 | -5.57 | 16.93 | 25 | NO |
| | 802.11ac-VHT40 | 22.50 | -5.57 | 16.93 | 25 | NO |
| | 802.11ax-HE20 | 22.00 | -5.58 | 16.42 | 25 | NO |
| | 802.11ax-HE40 | 22.00 | -5.58 | 16.42 | 25 | NO |
| | 802.11be-EHT20 | 18.50 | -28.73 | -10.23 | 25 | NO |
| 802.11be-EHT40 | 17.50 | -28.73 | -11.23 | 25 | NO | |
| 5GHz WLAN Ant 14 | 802.11a | 23.00 | -3.15 | 19.85 | 25 | NO |
| | 802.11n-HT20 | 23.00 | -13.44 | 9.56 | 25 | NO |
| | 802.11n-HT40 | 22.50 | -13.44 | 9.06 | 25 | NO |
| | 802.11ac-VHT20 | 23.00 | -5.57 | 17.43 | 25 | NO |
| | 802.11ac-VHT40 | 22.50 | -5.57 | 16.93 | 25 | NO |
| | 802.11ac-VHT80 | 22.50 | -5.57 | 16.93 | 25 | NO |
| | 802.11ac-VHT160 | 18.50 | -5.57 | 12.93 | 25 | NO |
| | 802.11ax-HE20 | 22.50 | -5.58 | 16.92 | 25 | NO |
| | 802.11ax-HE40 | 22.50 | -5.58 | 16.92 | 25 | NO |
| | 802.11ax-HE80 | 21.50 | -5.58 | 15.92 | 25 | NO |
| | 802.11ax-HE160 | 18.50 | -5.58 | 12.92 | 25 | NO |
| | 802.11be-EHT20 | 19.50 | -28.73 | -9.23 | 25 | NO |
| | 802.11be-EHT40 | 19.50 | -28.73 | -9.23 | 25 | NO |
| | 802.11be-EHT80 | 19.50 | -28.73 | -9.23 | 25 | NO |
| 802.11be-EHT160 | 18.50 | -28.73 | -10.23 | 25 | NO | |
| 6GHz WLAN Ant 14 | 802.11a | 7.00 | -3.15 | 3.85 | 25 | NO |
| | 802.11ax-HE20 | 6.00 | -5.58 | 0.42 | 25 | NO |
| | 802.11ax-HE40 | 11.50 | -5.58 | 5.92 | 25 | NO |
| | 802.11be-EHT20 | 6.00 | -28.73 | -22.73 | 25 | NO |
| | 802.11be-EHT40 | 11.50 | -28.73 | -17.23 | 25 | NO |



| Frequency Band | | Average Power (dBm) | Worst Case MIF (dB) | Power + MIF (dBm) | C63.19 Lowest RF _{AIPL} (dBm) | C63.19 RF _{AIL} Test Required |
|-----------------------|-----------------|---------------------|---------------------|-------------------|--|--|
| 2.4GHz WLAN Ant 10 | 802.11b | 22.50 | -2.02 | 20.48 | 25 | NO |
| | 802.11g | 22.50 | 0.12 | 22.62 | 25 | NO |
| | 802.11n-HT20 | 22.50 | -13.44 | 9.06 | 25 | NO |
| | 802.11n-HT40 | 22.50 | -13.44 | 9.06 | 25 | NO |
| | 802.11ac-VHT20 | 22.50 | -5.57 | 16.93 | 25 | NO |
| | 802.11ac-VHT40 | 22.50 | -5.57 | 16.93 | 25 | NO |
| | 802.11ax-HE20 | 22.00 | -5.58 | 16.42 | 25 | NO |
| | 802.11ax-HE40 | 22.00 | -5.58 | 16.42 | 25 | NO |
| 5GHz WLAN Ant 15 | 802.11be-EHT20 | 18.50 | -28.73 | -10.23 | 25 | NO |
| | 802.11be-EHT40 | 17.50 | -28.73 | -11.23 | 25 | NO |
| | 802.11a | 23.00 | -3.15 | 19.85 | 25 | NO |
| | 802.11n-HT20 | 23.00 | -13.44 | 9.56 | 25 | NO |
| | 802.11n-HT40 | 22.50 | -13.44 | 9.06 | 25 | NO |
| | 802.11ac-VHT20 | 23.00 | -5.57 | 17.43 | 25 | NO |
| | 802.11ac-VHT40 | 22.50 | -5.57 | 16.93 | 25 | NO |
| | 802.11ac-VHT80 | 22.50 | -5.57 | 16.93 | 25 | NO |
| | 802.11ac-VHT160 | 18.50 | -5.57 | 12.93 | 25 | NO |
| | 802.11ax-HE20 | 22.50 | -5.58 | 16.92 | 25 | NO |
| | 802.11ax-HE40 | 21.50 | -5.58 | 15.92 | 25 | NO |
| | 802.11ax-HE80 | 21.00 | -5.58 | 15.42 | 25 | NO |
| | 802.11ax-HE160 | 18.50 | -5.58 | 12.92 | 25 | NO |
| | 802.11be-EHT20 | 19.50 | -28.73 | -9.23 | 25 | NO |
| 802.11be-EHT40 | 19.50 | -28.73 | -9.23 | 25 | NO | |
| 802.11be-EHT80 | 19.50 | -28.73 | -9.23 | 25 | NO | |
| 802.11be-EHT160 | 18.50 | -28.73 | -10.23 | 25 | NO | |
| 6GHz WLAN Ant 15 | 802.11a | 7.50 | -3.15 | 4.35 | 25 | NO |
| | 802.11ax-HE20 | 7.50 | -5.58 | 1.92 | 25 | NO |
| | 802.11ax-HE40 | 11.00 | -5.58 | 5.42 | 25 | NO |
| | 802.11be-EHT20 | 7.50 | -28.73 | -21.23 | 25 | NO |
| | 802.11be-EHT40 | 11.00 | -28.73 | -17.73 | 25 | NO |



| Frequency Band | | Average Power (dBm) | Worst Case MIF (dB) | Power + MIF (dBm) | C63.19 Lowest RF _{AIPL} (dBm) | C63.19 RF _{AIL} Test Required |
|--------------------------|-----------------|---------------------|---------------------|-------------------|--|--|
| 2.4GHz WLAN Ant 13+10 | 802.11b | 25.50 | -2.02 | 23.48 | 25 | NO |
| | 802.11g | 22.00 | 0.12 | 22.12 | 25 | NO |
| | 802.11n-HT20 | 22.00 | -13.44 | 8.56 | 25 | NO |
| | 802.11n-HT40 | 21.00 | -13.44 | 7.56 | 25 | NO |
| | 802.11ac-VHT20 | 22.00 | -5.57 | 16.43 | 25 | NO |
| | 802.11ac-VHT40 | 21.00 | -5.57 | 15.43 | 25 | NO |
| | 802.11ax-HE20 | 21.50 | -5.58 | 15.92 | 25 | NO |
| | 802.11ax-HE40 | 20.80 | -5.58 | 15.22 | 25 | NO |
| 5GHz WLAN Ant 14+15 | 802.11be-EHT20 | 21.50 | -28.73 | -7.23 | 25 | NO |
| | 802.11be-EHT40 | 20.50 | -28.73 | -8.23 | 25 | NO |
| | 802.11a | 23.00 | -3.15 | 19.85 | 25 | NO |
| | 802.11n-HT20 | 23.00 | -13.44 | 9.56 | 25 | NO |
| | 802.11n-HT40 | 23.00 | -13.44 | 9.56 | 25 | NO |
| | 802.11ac-VHT20 | 23.00 | -5.57 | 17.43 | 25 | NO |
| | 802.11ac-VHT40 | 23.00 | -5.57 | 17.43 | 25 | NO |
| | 802.11ac-VHT80 | 23.00 | -5.57 | 17.43 | 25 | NO |
| | 802.11ac-VHT160 | 21.50 | -5.57 | 15.93 | 25 | NO |
| | 802.11ax-HE20 | 22.50 | -5.58 | 16.92 | 25 | NO |
| | 802.11ax-HE40 | 22.50 | -5.58 | 16.92 | 25 | NO |
| | 802.11ax-HE80 | 22.50 | -5.58 | 16.92 | 25 | NO |
| | 802.11ax-HE160 | 21.50 | -5.58 | 15.92 | 25 | NO |
| | 802.11be-EHT20 | 22.50 | -28.73 | -6.23 | 25 | NO |
| 802.11be-EHT40 | 22.50 | -28.73 | -6.23 | 25 | NO | |
| 802.11be-EHT80 | 22.50 | -28.73 | -6.23 | 25 | NO | |
| 802.11be-EHT160 | 21.50 | -28.73 | -7.23 | 25 | NO | |
| 6GHz WLAN Ant 14+15 | 802.11a | 10.00 | -3.15 | 6.85 | 25 | NO |
| | 802.11ax-HE20 | 10.00 | -5.58 | 4.42 | 25 | NO |
| | 802.11ax-HE40 | 14.50 | -5.58 | 8.92 | 25 | NO |
| | 802.11be-EHT20 | 10.00 | -28.73 | -18.73 | 25 | NO |
| | 802.11be-EHT40 | 14.50 | -28.73 | -14.23 | 25 | NO |



12. Conducted RF Output Power (Unit: dBm)

<GSM>

| Average Antenna Input Power(dBm) | | | | | | |
|----------------------------------|-------------|-------|-------|--------------|--------|--------|
| Band | GSM850 Ant1 | | | GSM1900 Ant5 | | |
| Channel | 128 | 189 | 251 | 512 | 661 | 810 |
| Frequency (MHz) | 824.2 | 836.4 | 848.8 | 1850.2 | 1880.0 | 1909.8 |
| GSM (GMSK, 1 Tx slot) | 32.75 | 32.80 | 32.77 | 30.66 | 30.60 | 30.77 |

<LTE>

| Band 41_HPUE_Ant 5 | | | | | | | | |
|--------------------|------------|---------|-----------|-----------------------|------------------------------|--------------------------|-------------------------------|------------------------|
| BW [MHz] | Modulation | RB Size | RB Offset | Power Low Ch. / Freq. | Power Low Middle Ch. / Freq. | Power Middle Ch. / Freq. | Power High Middle Ch. / Freq. | Power High Ch. / Freq. |
| Channel | | | | 39750 | 40185 | 40620 | 41055 | 41490 |
| Frequency (MHz) | | | | 2506 | 2549.5 | 2593 | 2636.5 | 2680 |
| 20 | QPSK | 1 | 0 | 26.85 | 26.90 | 26.89 | 26.84 | 26.88 |

| Band 41_HPUE_Ant 6 | | | | | | | | |
|--------------------|------------|---------|-----------|-----------------------|------------------------------|--------------------------|-------------------------------|------------------------|
| BW [MHz] | Modulation | RB Size | RB Offset | Power Low Ch. / Freq. | Power Low Middle Ch. / Freq. | Power Middle Ch. / Freq. | Power High Middle Ch. / Freq. | Power High Ch. / Freq. |
| Channel | | | | 39750 | 40185 | 40620 | 41055 | 41490 |
| Frequency (MHz) | | | | 2506 | 2549.5 | 2593 | 2636.5 | 2680 |
| 20 | QPSK | 1 | 49 | 26.64 | 26.65 | 26.49 | 26.56 | 26.44 |

| Band 41_HPUE_Ant 7 | | | | | | | | |
|--------------------|------------|---------|-----------|-----------------------|------------------------------|--------------------------|-------------------------------|------------------------|
| BW [MHz] | Modulation | RB Size | RB Offset | Power Low Ch. / Freq. | Power Low Middle Ch. / Freq. | Power Middle Ch. / Freq. | Power High Middle Ch. / Freq. | Power High Ch. / Freq. |
| Channel | | | | 39750 | 40185 | 40620 | 41055 | 41490 |
| Frequency (MHz) | | | | 2506 | 2549.5 | 2593 | 2636.5 | 2680 |
| 20 | QPSK | 1 | 0 | 26.35 | 26.42 | 26.29 | 26.33 | 26.38 |

<5G NR>

| FCC_n41(HPUE)_Ant 5 | | | | | | |
|---------------------|------------|---------|-----------|-----------------------|--------------------------|------------------------|
| BW [MHz] | Modulation | RB Size | RB Offset | Power Low Ch. / Freq. | Power Middle Ch. / Freq. | Power High Ch. / Freq. |
| Channel | | | | 509202 | 518598 | 528000 |
| Frequency (MHz) | | | | 2546.01 | 2592.99 | 2640 |
| 100 | QPSK | 1 | 1 | 24.51 | 26.29 | 26.25 |

| FCC_n41(HPUE)_Ant 0 | | | | | | |
|---------------------|------------|---------|-----------|-----------------------|--------------------------|------------------------|
| BW [MHz] | Modulation | RB Size | RB Offset | Power Low Ch. / Freq. | Power Middle Ch. / Freq. | Power High Ch. / Freq. |
| Channel | | | | 509202 | 518598 | 528000 |
| Frequency (MHz) | | | | 2546.01 | 2592.99 | 2640 |
| 100 | QPSK | 1 | 1 | 23.56 | 25.42 | 25.41 |

| FCC_n41(HPUE)_Ant 6 | | | | | | |
|---------------------|------------|---------|-----------|-----------------------|--------------------------|------------------------|
| BW [MHz] | Modulation | RB Size | RB Offset | Power Low Ch. / Freq. | Power Middle Ch. / Freq. | Power High Ch. / Freq. |
| Channel | | | | 509202 | 518598 | 528000 |
| Frequency (MHz) | | | | 2546.01 | 2592.99 | 2640 |
| 100 | QPSK | 1 | 1 | 22.53 | 25.31 | 25.27 |



| FCC_n41(HPUE)_Ant 7 | | | | | | |
|---------------------|------------|---------|-----------|-----------------------|--------------------------|------------------------|
| BW [MHz] | Modulation | RB Size | RB Offset | Power Low Ch. / Freq. | Power Middle Ch. / Freq. | Power High Ch. / Freq. |
| Channel | | | | 509202 | 518598 | 528000 |
| Frequency (MHz) | | | | 2546.01 | 2592.99 | 2640 |
| 100 | QPSK | 1 | 1 | 23.06 | 25.81 | 25.68 |

| Part27Q_n77(HPUE)_Ant 10 | | | | | | |
|--------------------------|------------|---------|-----------|-----------------------|--------------------------|------------------------|
| BW [MHz] | Modulation | RB Size | RB Offset | Power Low Ch. / Freq. | Power Middle Ch. / Freq. | Power High Ch. / Freq. |
| Channel | | | | | 633332 | |
| Frequency (MHz) | | | | | 3499.98 | |
| 100 | QPSK | 1 | 1 | | 26.30 | |

| Part27Q_n77(HPUE)_Ant 10 | | | | | | |
|--------------------------|------------|---------|-----------|-----------------------|--------------------------|------------------------|
| BW [MHz] | Modulation | RB Size | RB Offset | Power Low Ch. / Freq. | Power Middle Ch. / Freq. | Power High Ch. / Freq. |
| Channel | | | | 650000 | 656000 | 662000 |
| Frequency (MHz) | | | | 3750 | 3840 | 3930 |
| 100 | QPSK | 1 | 1 | 26.00 | 25.88 | 25.50 |

| Part27Q_n77(HPUE)_Ant 6 | | | | | | |
|-------------------------|------------|---------|-----------|-----------------------|--------------------------|------------------------|
| BW [MHz] | Modulation | RB Size | RB Offset | Power Low Ch. / Freq. | Power Middle Ch. / Freq. | Power High Ch. / Freq. |
| Channel | | | | | 633332 | |
| Frequency (MHz) | | | | | 3499.98 | |
| 100 | QPSK | 1 | 1 | | 25.80 | |

| Part27Q_n77(HPUE)_Ant 6 | | | | | | |
|-------------------------|------------|---------|-----------|-----------------------|--------------------------|------------------------|
| BW [MHz] | Modulation | RB Size | RB Offset | Power Low Ch. / Freq. | Power Middle Ch. / Freq. | Power High Ch. / Freq. |
| Channel | | | | 650000 | 656000 | 662000 |
| Frequency (MHz) | | | | 3750 | 3840 | 3930 |
| 100 | QPSK | 1 | 1 | 26.10 | 25.90 | 25.86 |

| Part27Q_n78(HPUE)_Ant 10 | | | | | | |
|--------------------------|------------|---------|-----------|-----------------------|--------------------------|------------------------|
| BW [MHz] | Modulation | RB Size | RB Offset | Power Low Ch. / Freq. | Power Middle Ch. / Freq. | Power High Ch. / Freq. |
| Channel | | | | | 633332 | |
| Frequency (MHz) | | | | | 3499.98 | |
| 100 | QPSK | 1 | 1 | | 26.22 | |

| Part27Q_n78(HPUE)_Ant 10 | | | | | | |
|--------------------------|------------|---------|-----------|-----------------------|--------------------------|------------------------|
| BW [MHz] | Modulation | RB Size | RB Offset | Power Low Ch. / Freq. | Power Middle Ch. / Freq. | Power High Ch. / Freq. |
| Channel | | | | | 650000 | |
| Frequency (MHz) | | | | | 3750 | |
| 100 | QPSK | 1 | 1 | | 25.95 | |



| Part27Q_n78(HPUE)_Ant 6 | | | | | | |
|-------------------------|------------|---------|-----------|-----------------------|--------------------------|------------------------|
| BW [MHz] | Modulation | RB Size | RB Offset | Power Low Ch. / Freq. | Power Middle Ch. / Freq. | Power High Ch. / Freq. |
| Channel | | | | | 633332 | |
| Frequency (MHz) | | | | | 3499.98 | |
| 100 | QPSK | 1 | 1 | | 25.68 | |

| Part27O_n78(HPUE)_Ant 6 | | | | | | |
|-------------------------|------------|---------|-----------|-----------------------|--------------------------|------------------------|
| BW [MHz] | Modulation | RB Size | RB Offset | Power Low Ch. / Freq. | Power Middle Ch. / Freq. | Power High Ch. / Freq. |
| Channel | | | | | 650000 | |
| Frequency (MHz) | | | | | 3750 | |
| 100 | QPSK | 1 | 1 | | 26.00 | |

| FCC_n41(UL MIMO)_Ant 5+7 | | | | | | |
|--------------------------|------------|---------|-----------|-----------------------|--------------------------|------------------------|
| BW [MHz] | Modulation | RB Size | RB Offset | Power Low Ch. / Freq. | Power Middle Ch. / Freq. | Power High Ch. / Freq. |
| Channel | | | | 509202 | 518598 | 528000 |
| Frequency (MHz) | | | | 2546.01 | 2592.99 | 2640 |
| 100 | QPSK | 1 | 1 | 27.51 | 28.97 | 28.93 |

| FCC_n41(UL MIMO)_Ant 0+6 | | | | | | |
|--------------------------|------------|---------|-----------|-----------------------|--------------------------|------------------------|
| BW [MHz] | Modulation | RB Size | RB Offset | Power Low Ch. / Freq. | Power Middle Ch. / Freq. | Power High Ch. / Freq. |
| Channel | | | | 509202 | 518598 | 528000 |
| Frequency (MHz) | | | | 2546.01 | 2592.99 | 2640 |
| 100 | QPSK | 1 | 1 | 26.94 | 28.21 | 28.33 |



13. RF_{AIL} Test Results

General Note:

- 1. The HAC measurement system applies MIF value onto the measured RMS E-field, which is indirect method in ANSI C63.19-2019 version, and reports the RF audio interference level.
2. Phone Condition: Mute on; Backlight off; Max Volume.
3. Since the LTE B41 power class 3 maximum power plus MIF is complies with ANSI63.19-2019 Table 4.1 RF_{AIPL}, therefore, only power class2 evaluated RF_{AIL}.

Table with 11 columns: Plot No., Air Interface, BW (MHz), Modulation / Mode, RB Size, RB offset, Channel, Transmit Ant., Average Antenna Input Power (dBm), MIF, E-Field (dBV/m). Rows 1-42 contain test data for various interfaces like GSM850, LTE Band 41_PC2, and FR1 n41/n77 PC2.

Test Engineer : Hank Huang, Kevin Xu, David Dai, Bin He



14. Uncertainty Assessment

The component of uncertainty may generally be categorized according to the methods used to evaluate them. The evaluation of uncertainty by the statistical analysis of a series of observations is termed a Type A evaluation of uncertainty. The evaluation of uncertainty by means other than the statistical analysis of a series of observation is termed a Type B evaluation of uncertainty. Each component of uncertainty, however evaluated, is represented by an estimated standard deviation, termed standard uncertainty, which is determined by the positive square root of the estimated variance.

The combined standard uncertainty of the measurement result represents the estimated standard deviation of the result. It is obtained by combining the individual standard uncertainties of both Type A and Type B evaluation using the usual "root-sum-squares" (RSS) methods of combining standard deviations by taking the positive square root of the estimated variances. Expanded uncertainty is a measure of uncertainty that defines an interval about the measurement result within which the measured value is confidently believed to lie. It is obtained by multiplying the combined standard uncertainty by a coverage factor. For purpose of this document, a coverage factor two is used, which corresponds to confidence interval of about 95 %. The DASy uncertainty Budget is showed below Table.

The judgment of conformity in the report is based on the measurement results excluding the measurement uncertainty.

| Error Description | Uncertainty Value (±%) | Probability Distribution | Divisor | Ci (Eav) | Standard Uncertainty (E) (±%) |
|--|------------------------|--------------------------|---------|----------|-------------------------------|
| Measurement System | | | | | |
| Probe Calibration | 5.1 | Normal | 1 | 1 | 5.1 |
| Axial Isotropy | 4.7 | Rectangular | √3 | 1 | 2.7 |
| Sensor Displacement | 7.2 | Rectangular | √3 | 0.5 | 2.1 |
| Boundary Effects | 2.4 | Rectangular | √3 | 1 | 1.4 |
| Phantom Boundary Effects | 7.2 | Rectangular | √3 | 1 | 4.2 |
| Linearity | 4.7 | Rectangular | √3 | 1 | 2.7 |
| Scaling with PMR Calibration | 10.0 | Rectangular | √3 | 1 | 5.8 |
| System Detection Limit | 1.0 | Rectangular | √3 | 1 | 0.6 |
| Readout Electronics | 0.3 | Normal | 1 | 1 | 0.3 |
| Response Time | 0.8 | Rectangular | √3 | 0 | 0.0 |
| Integration Time | 2.6 | Rectangular | √3 | 0 | 0.0 |
| RF Ambient Conditions | 3.0 | Rectangular | √3 | 1 | 1.7 |
| RF Reflections | 12.0 | Rectangular | √3 | 1 | 6.9 |
| Probe Positioner | 1.2 | Rectangular | √3 | 1 | 0.7 |
| Probe Positioning | 3.0 | Rectangular | √3 | 1 | 1.7 |
| Extrap. and Interpolation | 1.0 | Rectangular | √3 | 1 | 0.6 |
| Test Sample Related | | | | | |
| Device Positioning Vertical | 4.7 | Rectangular | √3 | 1 | 2.7 |
| Device Positioning Lateral | 1.0 | Rectangular | √3 | 1 | 0.6 |
| Device Holder and Phantom | 2.4 | Rectangular | √3 | 1 | 1.4 |
| Power Drift | 5.0 | Rectangular | √3 | 1 | 2.9 |
| Phantom and Setup Related | | | | | |
| Phantom Thickness | 2.4 | Rectangular | √3 | 1 | 1.4 |
| Combined Std. Uncertainty | | | | | 13.1% |
| Coverage Factor for 95 % | | | | | K=2 |
| Expanded STD Uncertainty | | | | | 26.3% |
| Declaration of Conformity: The test results with all measurement uncertainty excluded are presented in accordance with the regulation limits or requirements declared by manufacturers. | | | | | |
| Comments and Explanations: The declared of product specification for EUT presented in the report are provided by the manufacturer, and the manufacturer takes all the responsibilities for the accuracy of product specification. | | | | | |

Uncertainty Budget of HAC free field assessment



15. References

- [1] ANSI C63.19:2019, "American National Standard for Methods of Measurement of Compatibility between Wireless Communications Devices and Hearing Aids", Aug. 2019.
- [2] FCC KDB 285076 D01v06r04, "Equipment Authorization Guidance for Hearing Aid Compatibility", Sep 2023.
- [3] FCC KDB 285076 D03v01r06, "Hearing aid compatibility frequently asked questions", Jul. 2022
- [4] SPEAG DASY System Handbook