



# FCC RF Test Report

APPLICANT : OnePlus Technology (Shenzhen) Co., Ltd.  
EQUIPMENT : Mobile Phone  
BRAND NAME : ONEPLUS, [i]  
MODEL NAME : CPH2655  
FCC ID : 2ABZ2-OP23895  
STANDARD : 47 CFR Part 96  
CLASSIFICATION : Citizens Band End User Devices (CBE)  
EQUIPMENT TYPE : End User Equipment  
TEST DATE(S) : Aug. 06, 2024 ~ Aug. 13, 2024

We, Sporton International Inc. (Shenzhen), would like to declare that the tested sample has been evaluated in accordance with the procedures given in ANSI C63.26 and shown compliance with the applicable technical standards.

The test results in this report apply exclusively to the tested model / sample. Without written approval of Sporton International Inc. (Shenzhen), the test report shall not be reproduced except in full.

Jason Jia



Approved by: Jason Jia

**Sporton International Inc. (ShenZhen)**

**1/F, 2/F, Bldg 5, Shiling Industrial Zone, Xinwei Village, Xili, Nanshan, Shenzhen, 518055**

**People's Republic of China**



# Table of Contents

History of this test report..... 3

Summary of Test Result..... 4

**1 General Description ..... 5**

    1.1 Applicant..... 5

    1.2 Manufacturer ..... 5

    1.3 Feature of Equipment Under Test..... 5

    1.4 Maximum EIRP Power and Emission Designator ..... 6

    1.5 Testing Site..... 6

    1.6 Test Software ..... 7

    1.7 Applied Standards ..... 7

**2 Test Configuration of Equipment Under Test ..... 8**

    2.1 Test Mode..... 8

    2.2 Connection Diagram of Test System ..... 9

    2.3 Support Unit used in test configuration ..... 9

    2.4 Measurement Results Explanation Example ..... 9

    2.5 Frequency List of Low/Middle/High Channels..... 10

**3 Conducted Test Items..... 11**

    3.1 Measuring Instruments..... 11

    3.2 Conducted Output Power ..... 12

    3.3 Peak-to-Average Ratio ..... 13

    3.4 EIRP ..... 14

    3.5 Occupied Bandwidth ..... 15

    3.6 Conducted Band Edge ..... 16

    3.7 Conducted Spurious Emission ..... 17

    3.8 Frequency Stability..... 18

**4 Radiated Test Items ..... 19**

    4.1 Measuring Instruments..... 19

    4.2 Test Setup ..... 19

    4.3 Test Result of Radiated Test..... 20

    4.4 Radiated Spurious Emission ..... 21

**5 List of Measuring Equipment..... 22**

**6 Measurement Uncertainty ..... 23**

**Appendix A. Test Results of Conducted Test**

**Appendix B. Test Results of Radiated Test**

**Appendix C. Test Setup Photographs**



### History of this test report

Report No.	Version	Description	Issued Date
FG461101L	01	Initial issue of report	Sep. 27, 2024



### Summary of Test Result

Report Clause	Ref Std. Clause	Test Items	Result (PASS/FAIL)	Remark
3.2	§2.1046	Conducted Output Power	Reporting only	-
3.3	§96.41	Peak-to-Average Ratio	Pass	Not applicable for End User Devices
3.4	§96.41	Maximum E.I.R.P	Pass	-
		Maximum Power Spectral Density	Not Applicable	Not applicable for End User Devices
3.5	§2.1049 §96.41	Occupied Bandwidth	Reporting only	-
3.6	§2.1051 §96.41	Conducted Band Edge Measurement Adjacent Channel Leakage Ratio	Pass	-
3.7	§2.1051 §96.41	Conducted Spurious Emission	Pass	
3.8	§2.1055	Frequency Stability for Temperature & Voltage	Pass	-
4.4	§2.1051 §96.41	Radiated Spurious Emission	Pass	Under limit 11.47 dB at 10818.69 MHz

**Conformity Assessment Condition:**

1. The test results (PASS/FAIL) with all measurement uncertainty excluded are presented against the regulation limits or in accordance with the requirements stipulated by the applicant/manufacturer who shall bear all the risks of non-compliance that may potentially occur if measurement uncertainty is taken into account.
2. The measurement uncertainty please refer to each test result in the section "Measurement Uncertainty"

**Disclaimer:**

The product specifications of the EUT presented in the test report that may affect the test assessments are declared by the manufacturer who shall take full responsibility for the authenticity.

# 1 General Description

## 1.1 Applicant

**OnePlus Technology (Shenzhen) Co., Ltd**

18C02, 18C03, 18C04, and 18C05, Shum Yip Terra Building, Binhe Avenue North, Futian District, Shenzhen, Guangdong, P.R. China.

## 1.2 Manufacturer

**OnePlus Technology (Shenzhen) Co., Ltd.**

18C02, 18C03, 18C04, and 18C05, Shum Yip Terra Building, Binhe Avenue North, Futian District, Shenzhen, Guangdong, P.R. China.

## 1.3 Feature of Equipment Under Test

Product Feature	
Equipment	Mobile Phone
Brand Name	ONEPLUS, 
Model Name	CPH2655
FCC ID	2ABZ2-OP23895
Tx Frequency	5G NR n48: 3550 MHz ~ 3700 MHz
Rx Frequency	5G NR n48: 3550 MHz ~ 3700 MHz
SCS	30kHz
Bandwidth	10MHz / 15MHz / 20MHz / 30MHz / 40MHz
Antenna Gain	<Ant. 6>: 5G NR n48: -2.0 dBi <Ant. 10>: 5G NR n48: -2.5 dBi <Ant. 11>: 5G NR n48: -2.5 dBi <Ant. 12>: 5G NR n48: -1.0 dBi
Type of Modulation	DFT-s-OFDM (PI/2 BPSK / QPSK / 16QAM / 64QAM / 256QAM) CP-OFDM (QPSK / 16QAM / 64QAM / 256QAM)
IMEI Code	Conducted: 866493070032172/866493070032164 Radiation: 866493070032891/866493070032883
HW Version	11
SW Version	OxygenOS V15.0
EUT Stage	Production Unit

**Remark:**

1. The maximum EIRP is calculated from max output power and antenna gain, only the maximum EIRP of Ant. 12 is shown in the report.
2. 5G NR n48 support SA mode only.



### 1.4 Maximum EIRP Power and Emission Designator

5G NR n48		PI/2 BPSK / QPSK		16QAM/64QAM/256QAM	
BW (MHz)	Frequency Range (MHz)	Maximum EIRP(W)	Emission Designator (99%OBW)	Maximum EIRP(W)	Emission Designator (99%OBW)
10	3555.00~3694.98	0.1762	8M58G7D	0.1402	8M58W7D
15	3557.52~3692.50	0.1765	13M6G7D	0.1438	13M6W7D
20	3560.01~3690.00	0.1735	18M3G7D	0.1411	18M3W7D
30	3564.99~3684.99	0.1706	27M8G7D	0.1306	27M8W7D
40	3570.00~3679.98	0.1771	37M8G7D	0.1359	37M8W7D

### 1.5 Testing Site

Sporton International Inc. (ShenZhen) is accredited to ISO/IEC 17025:2017 by American Association for Laboratory Accreditation with Certificate Number 5145.01.

<b>Test Firm</b>	Sporton International Inc. (ShenZhen)		
<b>Test Site Location</b>	1/F, 2/F, Bldg 5, Shiling Industrial Zone, Xinwei Village, Xili, Nanshan, Shenzhen, 518055 People's Republic of China TEL: +86-755-86379589 FAX: +86-755-86379595		
<b>Test Site No.</b>	<b>Sporton Site No.</b>	<b>FCC Designation No.</b>	<b>FCC Test Firm Registration No.</b>
	TH01-SZ	CN1256	421272

<b>Test Firm</b>	Sporton International Inc. (ShenZhen)		
<b>Test Site Location</b>	101, 1st Floor, Block B, Building 1, No. 2, Tengfeng 4th Road, Fenghuang Community, Fuyong Street, Baoan District, Shenzhen City, Guangdong Province 518103 People's Republic of China TEL: +86-755-86066985		
<b>Test Site No.</b>	<b>Sporton Site No.</b>	<b>FCC Designation No.</b>	<b>FCC Test Firm Registration No.</b>
	03CH01-SZ	CN1256	421272



### 1.6 Test Software

Item	Site	Manufacture	Name	Version
1.	03CH01-SZ	AUDIX	E3	6.2009-8-24

### 1.7 Applied Standards

According to the specifications of the manufacturer, the EUT must comply with the requirements of the following standards:

- ♦ ANSI C63.26-2015
- ♦ 47 CFR Part 96
- ♦ FCC KDB 971168 D01 Power Meas. License Digital Systems v03r01
- ♦ FCC KDB 940660 D01 Part 96 CBRS v03
- ♦ FCC KDB 412172 D01 Determining ERP and EIRP v01r01

**Remark:**

1. All test items were verified and recorded according to the standards and without any deviation during the test.
2. This EUT has also been tested and complied with the requirements of FCC Part 15, Subpart B, recorded in a separate test report.



## 2 Test Configuration of Equipment Under Test

### 2.1 Test Mode

Antenna port conducted and radiated test items listed below are performed according to KDB 971168 D01 Power Meas. License Digital Systems v03r01 with maximum output power.

For radiated measurement, pre-scanned in three orthogonal panels, X, Y, Z. The worst cases (Z plane) were recorded in this report.

Test Items	Band	Bandwidth (MHz)						Modulation					RB #		Test Channel			
		5	10	15	20	30	40	PI/2 BPSK	QPSK	16QAM	64QAM	256 QAM	1	Full	L	M	H	
Max. Output Power	n48	-	v	v	v	v	v	v	v	v	v	v	v	v	v	v	v	v
Peak-to-Average Ratio	n48	-			v			v	v					v			v	
26dB and 99% Bandwidth	n48	-	v	v	v	v-	v		v	v	v	v		v			v	
Adjacent Channel Leakage Ratio	n48	-	v		v		v	v	v					v	v	v	v	v
Conducted Band Edge	n48	-	v		v		v	v	v					v	v	v	v	v
Conducted Spurious Emission	n48	-	v		v		v	v	v					v		v	v	v
E.I.R.P	n48	-	v	v	v	v	v	v	v	v	v	v	v	v	v	v	v	v
Frequency Stability	n48	-			v				v						v			v
Radiated Spurious Emission	n48	Worst Case													v	v	v	
Remark	<ol style="list-style-type: none"> <li>The mark "v" means that this configuration is chosen for testing</li> <li>The mark "-" means that this bandwidth is not supported.</li> <li>The device is investigated from 30MHz to 10 times of fundamental signal for radiated spurious emission test under different RB size/offset and modulations in exploratory test. Subsequently, only the worst case emissions are reported.</li> <li>All test items are based on engineering evaluation.</li> <li>Frequency Stability: Normal Voltage = 8.0V ; Low Voltage =7.2V; High Voltage =9.0V</li> </ol>																	



## 2.2 Connection Diagram of Test System

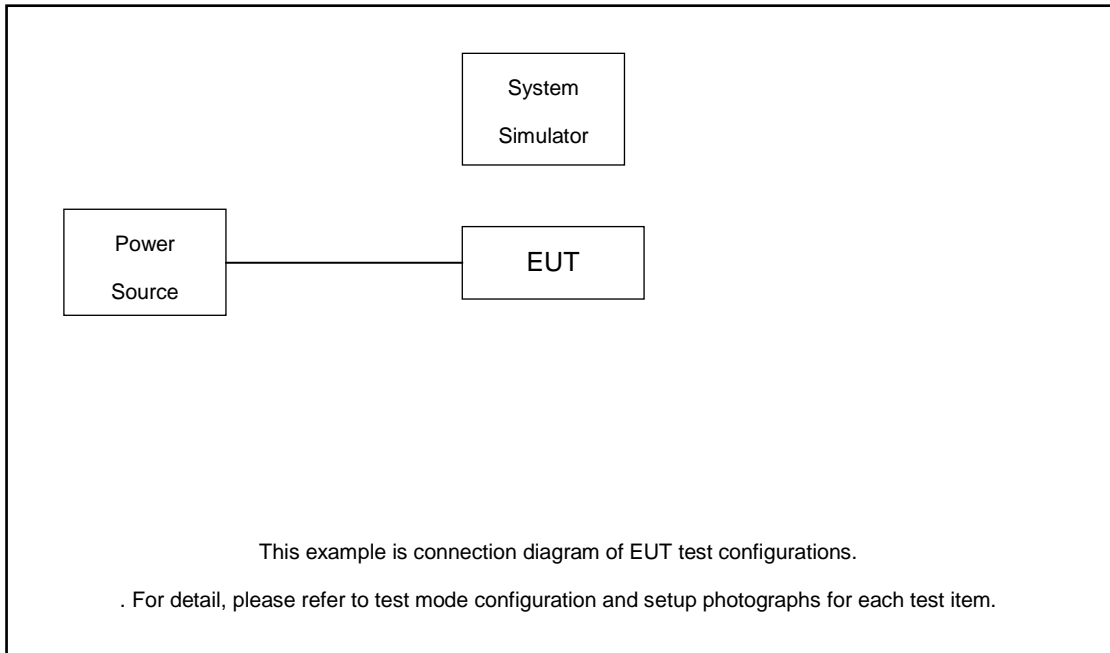

## 2.3 Support Unit used in test configuration

Item	Equipment	Trade Name	Model No.	FCC ID	Data Cable	Power Cord
1.	DC Power Supply	GW	GPS-3030D	N/A	N/A	Unshielded, 1.8 m
2.	LTE Base Station	Anritsu	MT8821C	N/A	N/A	Unshielded, 1.8 m
3.	NR Base Station	Anritsu	MT8000A	N/A	N/A	Unshielded, 1.8 m

## 2.4 Measurement Results Explanation Example

### For all conducted test items:

The offset level is set in the spectrum analyzer to compensate the RF cable loss between EUT conducted output port and spectrum analyzer. With the offset compensation, the spectrum analyzer reading level is exactly the EUT RF output level.

The spectrum analyzer offset is derived from RF cable loss.

*Offset = RF cable loss.*

Following shows an offset computation example with cable loss 8.9 dB.

Example :

$$\begin{aligned} \text{Offset(dB)} &= \text{RF cable loss(dB)}. \\ &= 8.9 \text{ (dB)} \end{aligned}$$



## 2.5 Frequency List of Low/Middle/High Channels

5G NR n48 Channel and Frequency List				
BW [MHz]	Channel/Frequency(MHz)	Lowest	Middle	Highest
40	Channel	638000	641666	645332
	Frequency	3570	3624.99	3679.98
30	Channel	637666	641666	645666
	Frequency	3564.99	3624.99	3684.99
20	Channel	637334	641666	646000
	Frequency	3560.01	3624.99	3690
15	Channel	637168	641666	646166
	Frequency	3557.52	3624.99	3692.49
10	Channel	637000	641666	646332
	Frequency	3555	3624.99	3694.98

### 3 Conducted Test Items

#### 3.1 Measuring Instruments

See list of measuring instruments of this test report.

##### 3.1.1 Test Setup

##### 3.1.2 Conducted Output Power / ACLR

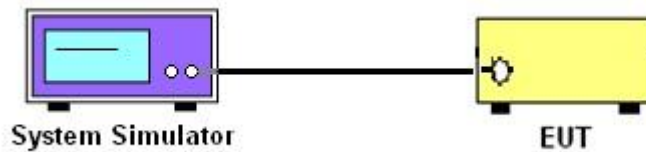

##### 3.1.3 Peak-to-Average Ratio, Occupied Bandwidth, Conducted Band-Edge and Conducted Spurious Emission

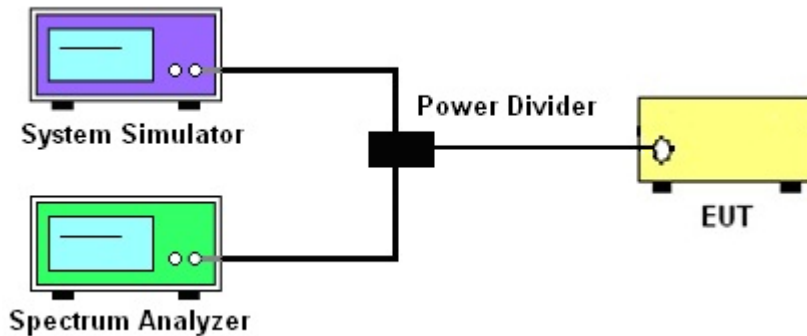

##### 3.1.4 Frequency Stability

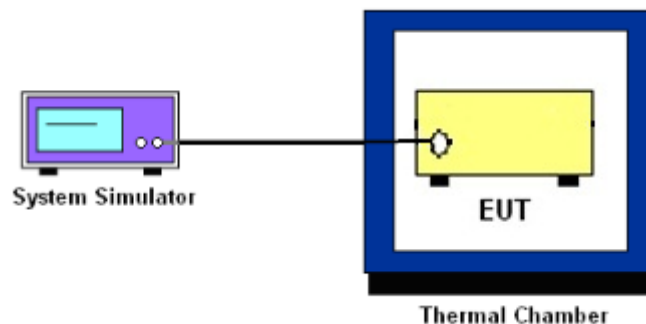

##### 3.1.5 Test Result of Conducted Test

Please refer to Appendix A.



## **3.2 Conducted Output Power**

### **3.2.1 Description of the Conducted Output Power Measurement**

A system simulator was used to establish communication with the EUT. Its parameters were set to force the EUT transmitting at maximum output power. The measured power in the radio frequency on the transmitter output terminals shall be reported.

### **3.2.2 Test Procedures**

1. The transmitter output port was connected to the system simulator.
2. Set EUT at maximum power through the system simulator.
3. Select lowest, middle, and highest channels for each band and different modulation.
4. Measure and record the power level from the system simulator.



### 3.3 Peak-to-Average Ratio

#### 3.3.1 Description of the PAR Measurement

Power Complementary Cumulative Distribution Function (CCDF) curves provide a means for characterizing the power peaks of a digitally modulated signal on a statistical basis. A CCDF curve depicts the probability of the peak signal amplitude exceeding the average power level. Most contemporary measurement instrumentation include the capability to produce CCDF curves for an input signal provided that the instrument's resolution bandwidth can be set wide enough to accommodate the entire input signal bandwidth. In measuring transmissions in this band using an average power technique, the peak-to-average ratio (PAR) of the transmission may not exceed 13 dB.

#### 3.3.2 Test Procedures

The testing follows ANSI C63.26-2015 Section 5.2.6

1. The EUT was connected to spectrum and system simulator via a power divider.
2. Set the CCDF (Complementary Cumulative Distribution Function) option in spectrum analyzer.
3. The highest RF powers were measured and recorded the maximum PAPR level associated with a probability of 0.1 %.
4. Record the deviation as Peak to Average Ratio

### 3.4 EIRP

#### 3.4.1 Description of the EIRP Measurement

EIRP limits for CBRS equipment as below table:

Device		Maximum EIRP (dBm/10 MHz)	Maximum PSD (dBm/MHz)
Applied	End User Device	23	n/a
<input type="checkbox"/>	Category A CBSD	30	20
<input type="checkbox"/>	Category B CBSD	47	37

**Remark:**

1. The worst case EIRP shown in this section is found with NR operating only using 1RB. As such, the EIRP/10MHz and full channel EIRP values will be identical since 1RB is fully contained within all available channel bandwidths for n48 (i.e. 10, 15, 20, 30, 40MHz)

#### 3.4.2 Test Procedures for EIRP

1. Establishing a communications link with the call box (Base station) to measure the Maximum conducted power, the parameters were set to force the EUT transmitting at maximum output power level. Use the average power measurement function to measure total channel power of each channel bandwidth (per ANSI C63.26-2015 Section 5.2.1)
2. Determining ERP and/or EIRP from conducted RF output power measurements (Per ANSI C63.26-2015 Section 5.2.5.5)
 

$EIRP = P_T + G_T - L_C$ ,  $ERP = EIRP - 2.15$ , where  
 $P_T$  = transmitter output power in dBm  
 $G_T$  = gain of the transmitting antenna in dBi  
 $L_C$  = signal attenuation in the connecting cable between the transmitter and antenna in dB



### 3.5 Occupied Bandwidth

#### 3.5.1 Description of Occupied Bandwidth Measurement

The occupied bandwidth is the width of a frequency band such that, below the lower and above the upper frequency limits, the mean powers emitted are each equal to a specified percentage 0.5% of the total mean transmitted power.

The 26 dB emission bandwidth is defined as the frequency range between two points, one above and one below the carrier frequency, at which the spectral density of the emission is attenuated 26 dB below the maximum in-band spectral density of the modulated signal. Spectral density (power per unit bandwidth) is to be measured with a detector of resolution bandwidth equal to approximately 1.0% of the emission bandwidth.

#### 3.5.2 Test Procedures

The testing follows ANSI C63.26-2015 Section 5.4.3 (26dB) and Section 5.4.4 (99OB)

1. The EUT was connected to spectrum analyzer and system simulator via a power divider.
2. The spectrum analyzer center frequency is set to the nominal EUT channel center frequency. The span range for the spectrum analyzer shall be between two and five times the anticipated OBW.
3. The nominal resolution bandwidth (RBW) shall be in the range of 1 to 5 % of the anticipated OBW, and the VBW shall be at least 3 times the RBW.
4. Set the detection mode to peak, and the trace mode to max hold.
5. Determine the reference value: Set the EUT to transmit a modulated signal. Allow the trace to stabilize. Set the spectrum analyzer marker to the highest level of the displayed trace.  
(this is the reference value)
6. Determine the “-26 dB down amplitude” as equal to (Reference Value – X).
7. Place two markers, one at the lowest and the other at the highest frequency of the envelope of the spectral display such that each marker is at or slightly below the “-X dB down amplitude” determined in step 6. If a marker is below this “-X dB down amplitude” value it shall be placed as close as possible to this value. The OBW is the positive frequency difference between the two markers.
8. Use the 99 % power bandwidth function of the spectrum analyzer and report the measured bandwidth.

## 3.6 Conducted Band Edge

### 3.6.1 Description of Conducted Band Edge Measurement

Part 96.41 (e) (1) (i)

For CBSD the emission limits outside the fundamental are as follows:

Within 0 MHz to 10 MHz above and below the assigned channel  $\leq -13$  dBm/MHz

Greater than 10 MHz above and below the assigned channel  $\leq -25$  dBm/MHz

Part 96.41 (e) (1) (ii)

For End User Devices the emission limits outside the fundamental are as follows:

Within 0 MHz to B MHz above and below the assigned channel  $\leq -13$  dBm/MHz

Greater than B MHz above and below the assigned channel  $\leq -25$  dBm/MHz

where B is the bandwidth in megahertz of the assigned channel or multiple contiguous channels of the End User Device.

Notwithstanding the emission limits in this paragraph, the Adjacent Channel Leakage Ratio for End User Devices shall be at least 30 dB.

Part 96.41 (e) (2)

For CBSDs and End User Devices, the conducted power of emissions below 3540 MHz or above 3710 MHz shall not exceed  $-25$  dBm/MHz, and the conducted power of emissions below 3530 MHz or above 3720 MHz shall not exceed  $-40$ dBm/MHz

### 3.6.2 Test Procedures

The testing follows FCC KDB 971168 D01 v03r01 Section 6.1.

1. The EUT was connected to spectrum analyzer and system simulator via a power divider.
2. The band edges of low and high channels for the highest RF powers were measured.
3. Set RBW  $\geq 1\%$  EBW in the 1MHz band immediately outside and adjacent to the band edge.
4. Beyond the 1 MHz band from the band edge, RBW=1MHz was used
5. Offset has included the duty factor for n48. Duty factor  $=10 \log (1/x)$ , where x is the measured duty cycle.
6. Set spectrum analyzer with RMS detector.
7. The RF fundamental frequency should be excluded against the limit line in the operating frequency band.





## 3.7 Conducted Spurious Emission

### 3.7.1 Description of Conducted Spurious Emission Measurement

96.41 (e)(2)

The conducted power of any emissions below 3530 MHz or above 3720 MHz shall not exceed -40dBm/MHz.

### 3.7.2 Test Procedures

The testing follows FCC KDB 971168 D01 v03r01 Section 6.1.

1. The EUT was connected to spectrum analyzer and system simulator via a power divider.
2. The RF output of EUT was connected to the spectrum analyzer by RF cable and attenuator. The path loss was compensated to the results for each measurement.
3. The middle channel for the highest RF power within the transmitting frequency was measured.
4. The conducted spurious emission for the whole frequency range was taken.
5. Make the measurement with the spectrum analyzer's RBW = 1MHz, VBW = 3MHz.
6. Set spectrum analyzer with RMS detector.
7. Taking the record of maximum spurious emission.
8. The RF fundamental frequency should be excluded against the limit line in the operating frequency band.
9. The limit line is -40dBm/MHz.

## 3.8 Frequency Stability

### 3.8.1 Description of Frequency Stability Measurement

The frequency stability shall be measured by variation of ambient temperature and variation of primary supply voltage to ensure that the fundamental emission stays within the authorized frequency block. The frequency stability of the transmitter shall be maintained within  $\pm 0.00025\%$  ( $\pm 2.5\text{ppm}$ ) of the center frequency

### 3.8.2 Test Procedures for Temperature Variation

The testing follows FCC KDB 971168 D01 v03r01 Section 9.0.

1. The EUT was set up in the thermal chamber and connected with the system simulator.
2. With power OFF, the temperature was decreased to  $-30^{\circ}\text{C}$  and the EUT was stabilized before testing. Power was applied and the maximum change in frequency was recorded within one minute.
3. With power OFF, the temperature was raised in  $10^{\circ}\text{C}$  step up to  $50^{\circ}\text{C}$ . The EUT was stabilized at each step for at least half an hour. Power was applied and the maximum frequency change was recorded within one minute.

### 3.8.3 Test Procedures for Voltage Variation

The testing follows FCC KDB 971168 D01 v03r01 Section 9.0.

1. The EUT was placed in a temperature chamber at  $25\pm 5^{\circ}\text{C}$  and connected with the system simulator.
2. The power supply voltage to the EUT was varied from 85% to 115% of the nominal value measured at the input to the EUT.
3. The variation in frequency was measured for the worst case.

## 4 Radiated Test Items

### 4.1 Measuring Instruments

See list of measuring instruments of this test report.

### 4.2 Test Setup

#### 4.2.1 For radiated test below 30MHz

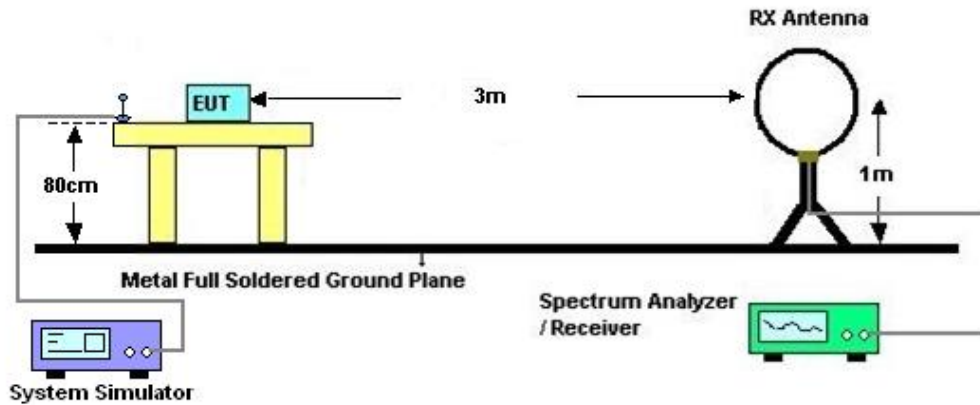

#### 4.2.2 For radiated test from 30MHz to 1GHz

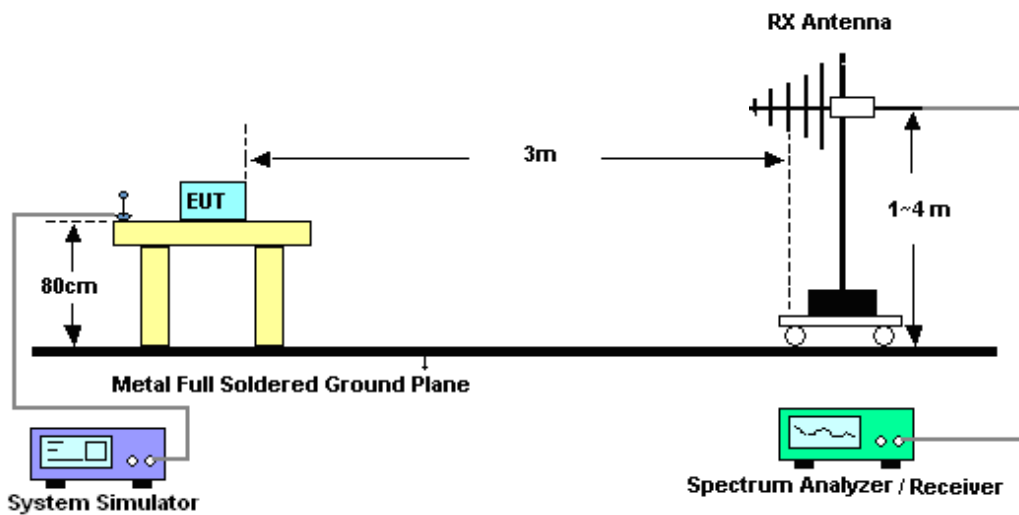

### 4.2.3 For radiated test above 1GHz

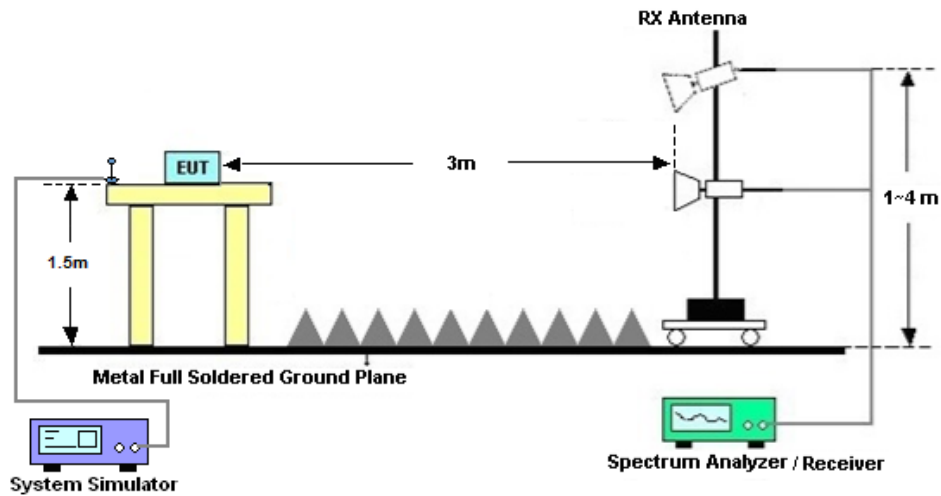

### 4.3 Test Result of Radiated Test

The low frequency, which started from 9 kHz to 30MHz, was pre-scanned and the result which was 20dB lower than the limit line was not reported.

Please refer to Appendix B.



## 4.4 Radiated Spurious Emission

### 4.4.1 Description of Radiated Spurious Emission Measurement

The radiated spurious emission was measured by substitution method according to ANSI C63.26. The power of any emission outside of the authorized operating frequency ranges must be attenuated below the transmitter power (P) by a factor of at least -40dBm / MHz.

The spectrum is scanned from 30 MHz up to a frequency including its 10th harmonic.

### 4.4.2 Test Procedures

1. The EUT was placed on a turntable with 0.8 meter height for frequency below 1GHz and 1.5 meter height for frequency above 1GHz respectively above ground.
2. The EUT was set 3 meters from the receiving antenna mounted on the antenna tower.
3. The table was rotated 360 degrees to determine the position of the highest spurious emission.
4. The height of the receiving antenna is varied between 1m to 4m to search the maximum spurious emission for both horizontal and vertical polarizations.
5. During the measurement, the system simulator parameters were set to force the EUT transmitting at maximum output power.
6. Make the measurement with the spectrum analyzer's RBW = 1MHz, VBW = 3MHz, taking the record of maximum spurious emission.
7. A horn antenna was substituted in place of the EUT and was driven by a signal generator. Tune the output power of signal generator to the same emission level with EUT maximum spurious emission.  
$$\text{EIRP (dBm)} = \text{S.G. Power} - \text{Tx Cable Loss} + \text{Tx Antenna Gain}$$
$$\text{ERP (dBm)} = \text{EIRP} - 2.15$$
8. The RF fundamental frequency should be excluded against the limit line in the operating frequency band.  
The limit line is -40dBm/MHz



## 5 List of Measuring Equipment

Instrument	Manufacturer	Model No.	Serial No.	Characteristics	Calibration Date	Test Date	Due Date	Remark
Spectrum Analyzer	R&S	FSV40	101078	10Hz~40GHz	Apr. 09, 2024	Aug 06, 2024~ Aug 13, 2024	Apr. 08, 2025	Conducted (TH01-SZ)
DC Power Supply	TTI	PL330P	290070	Max 32V , 3A	Oct. 16, 2023	Aug 06, 2024~ Aug 13, 2024	Oct. 15, 2024	Conducted (TH01-SZ)
Power Divider	TOJOIN	PS-2SM-04265	60.06.020.0077	0.4GHz~26.5GHz	Dec. 25, 2023	Aug 06, 2024~ Aug 13, 2024	Dec. 24, 2024	Conducted (TH01-SZ)
Thermal Chamber	Ten Billion Hongzhangroup	LP-150U	H2014081803	-40~+150°C	Jul. 03, 2024	Aug 06, 2024~ Aug 13, 2024	Jul. 02, 2025	Conducted (TH01-SZ)
EMI Test Receiver&SA	Agilent	N9038A	MY52260185	20Hz~26.5GHz	Dec. 27, 2023	Aug 06, 2024	Dec. 26, 2024	Radiation (03CH01-SZ)
Loop Antenna	R&S	HFH2-Z2E	101141	9kHz~30MHz	Dec. 29, 2023	Aug 06, 2024	Dec. 28, 2024	Radiation (03CH01-SZ)
HF Amplifier	KEYSIGHT	83017A	MY53270105	0.5GHz~26.5GHz	Oct. 18,2023	Aug 06, 2024	Oct. 17,2024	Radiation (03CH01-SZ)
Bilog Antenna	TeseQ	CBL6112D	35407	30MHz-2GHz	Oct. 24, 2023	Aug 06, 2024	Oct. 23, 2025	Radiation (03CH01-SZ)
Double Ridge Horn Antenna	ETS-Lindgren	3117	00119436	1GHz~18GHz	Jul. 04, 2024	Aug 06, 2024	Jul. 03, 2025	Radiation (03CH01-SZ)
SHF-EHF Horn	com-power	AH-840	101071	18GHz-40GHz	Apr. 09,2024	Aug 06, 2024	Apr. 08,2025	Radiation (03CH01-SZ)
LF Amplifier	Burgeon	BPA-530	102209	0.01~3000Mhz	Apr. 09, 2024	Aug 06, 2024	Apr. 08, 2025	Radiation (03CH01-SZ)
HF Amplifier	MITEQ	AMF-7D-00101800-30-10P-R	1943528	1GHz~18GHz	Oct. 18,2023	Aug 06, 2024	Oct. 17,2024	Radiation (03CH01-SZ)
HF Amplifier	MITEQ	TTA1840-35-HG	1871923	18GHz~40GHz	Jul. 03, 2024	Aug 06, 2024	Jul. 02, 2025	Radiation (03CH01-SZ)
AC Power Source	Chroma	61601	616010001985	N/A	Oct. 18,2023	Aug 06, 2024	Oct. 17,2024	Radiation (03CH01-SZ)
Turn Table	EM	EM1000	N/A	0~360 degree	NCR	Aug 06, 2024	NCR	Radiation (03CH01-SZ)
Antenna Mast	EM	EM1000	N/A	1 m~4 m	NCR	Aug 06, 2024	NCR	Radiation (03CH01-SZ)

NCR: No Calibration Required



## 6 Measurement Uncertainty

### Uncertainty of Conducted Measurement

Test Item	Uncertainty
Conducted Spurious Emission & Bandedge	±1.34 dB
Occupied Channel Bandwidth	±0.012 MHz
Conducted Power	±1.34 dB
Conducted Power Density	±1.34 dB
Peak to Average Ratio	±1.34 dB
Frequency Stability	±1.3 Hz

### Uncertainty of Radiated Emission Measurement (30 MHz ~ 1000 MHz)

Measuring Uncertainty for a Level of Confidence of 95% (U = 2Uc(y))	2.48 dB
---	---------

### Uncertainty of Radiated Emission Measurement (1 GHz ~ 18 GHz)

Measuring Uncertainty for a Level of Confidence of 95% (U = 2Uc(y))	3.53 dB
---	---------

### Uncertainty of Radiated Emission Measurement (18 GHz ~ 40 GHz)

Measuring Uncertainty for a Level of Confidence of 95% (U = 2Uc(y))	4.02 dB
---	---------

----- THE END -----



## Appendix A. Test Results of Conducted Test

Test Engineer :	Khan	Temperature :	24~26°C
		Relative Humidity :	50~53%





Software Version: 23.06.1602

# FR1 N48

## Transmitter Conducted Output Power And EIRP, (G<sub>T</sub> - L<sub>C</sub>)=-1dB

NR Band	SCS (kHz)	Bandwidth (MHz)	Arfcn	Freq (MHz)	Modulation	RB	Conducted Power(dBm)	EIRP (dBm)	EIRP (W)
48	30	10	637000	3555	DFT-s-OFDM PI/2 BPSK	12@6	23.19	22.19	0.1655
48	30	10	637000	3555	DFT-s-OFDM PI/2 BPSK	1@1	23.17	22.17	0.1649
48	30	10	637000	3555	DFT-s-OFDM PI/2 BPSK	1@22	23.21	22.21	0.1662
48	30	10	637000	3555	DFT-s-OFDM QPSK	12@6	23.11	22.11	0.1627
48	30	10	637000	3555	DFT-s-OFDM QPSK	1@1	23.06	22.06	0.1607
48	30	10	637000	3555	DFT-s-OFDM QPSK	1@22	23.13	22.13	0.1634
48	30	10	637000	3555	DFT-s-OFDM 16 QAM	12@6	22.17	21.17	0.1309
48	30	10	637000	3555	DFT-s-OFDM 16 QAM	1@1	22.17	21.17	0.1309
48	30	10	637000	3555	DFT-s-OFDM 16 QAM	1@22	22.31	21.31	0.1352
48	30	10	637000	3555	DFT-s-OFDM 64 QAM	12@6	20.53	19.53	0.0897
48	30	10	637000	3555	DFT-s-OFDM 64 QAM	1@1	20.64	19.64	0.0920
48	30	10	637000	3555	DFT-s-OFDM 64 QAM	1@22	20.68	19.68	0.0929
48	30	10	637000	3555	DFT-s-OFDM 256 QAM	12@6	18.60	17.60	0.0576
48	30	10	637000	3555	DFT-s-OFDM 256 QAM	1@1	18.50	17.50	0.0563
48	30	10	637000	3555	DFT-s-OFDM 256 QAM	1@22	18.62	17.62	0.0578
48	30	10	637000	3555	CP-OFDM QPSK	12@6	21.63	20.63	0.1156
48	30	10	637000	3555	CP-OFDM QPSK	1@1	21.66	20.66	0.1163
48	30	10	637000	3555	CP-OFDM QPSK	1@22	21.64	20.64	0.1160
48	30	10	641666	3624.99	DFT-s-OFDM PI/2 BPSK	12@6	23.36	22.36	0.1724
48	30	10	641666	3624.99	DFT-s-OFDM PI/2 BPSK	1@1	23.33	22.33	0.1710
48	30	10	641666	3624.99	DFT-s-OFDM PI/2 BPSK	1@22	23.45	22.45	0.1759
48	30	10	641666	3624.99	DFT-s-OFDM QPSK	12@6	23.30	22.30	0.1699
48	30	10	641666	3624.99	DFT-s-OFDM QPSK	1@1	23.30	22.30	0.1700
48	30	10	641666	3624.99	DFT-s-OFDM QPSK	1@22	23.41	22.41	0.1741
48	30	10	641666	3624.99	DFT-s-OFDM 16 QAM	12@6	22.31	21.31	0.1352
48	30	10	641666	3624.99	DFT-s-OFDM 16 QAM	1@1	22.31	21.31	0.1351
48	30	10	641666	3624.99	DFT-s-OFDM 16 QAM	1@22	22.37	21.37	0.1371
48	30	10	641666	3624.99	DFT-s-OFDM 64 QAM	12@6	20.75	19.75	0.0943
48	30	10	641666	3624.99	DFT-s-OFDM 64 QAM	1@1	20.81	19.81	0.0958
48	30	10	641666	3624.99	DFT-s-OFDM 64 QAM	1@22	20.84	19.84	0.0965
48	30	10	641666	3624.99	DFT-s-OFDM 256 QAM	12@6	18.79	17.79	0.0601
48	30	10	641666	3624.99	DFT-s-OFDM 256 QAM	1@1	18.67	17.67	0.0585
48	30	10	641666	3624.99	DFT-s-OFDM 256 QAM	1@22	18.84	17.84	0.0608
48	30	10	641666	3624.99	CP-OFDM QPSK	12@6	21.83	20.83	0.1209
48	30	10	641666	3624.99	CP-OFDM QPSK	1@1	21.75	20.75	0.1188
48	30	10	641666	3624.99	CP-OFDM QPSK	1@22	21.84	20.84	0.1214



48	30	10	646332	3694.98	DFT-s-OFDM PI/2 BPSK	12@6	23.43	22.43	0.1750
48	30	10	646332	3694.98	DFT-s-OFDM PI/2 BPSK	1@1	23.44	22.44	0.1753
48	30	10	646332	3694.98	DFT-s-OFDM PI/2 BPSK	1@22	23.42	22.42	0.1745
48	30	10	646332	3694.98	DFT-s-OFDM QPSK	12@6	23.41	22.41	0.1740
48	30	10	646332	3694.98	DFT-s-OFDM QPSK	1@1	23.34	22.34	0.1714
48	30	10	646332	3694.98	DFT-s-OFDM QPSK	1@22	23.46	22.46	0.1762
48	30	10	646332	3694.98	DFT-s-OFDM 16 QAM	12@6	22.42	21.42	0.1388
48	30	10	646332	3694.98	DFT-s-OFDM 16 QAM	1@1	22.47	21.47	0.1402
48	30	10	646332	3694.98	DFT-s-OFDM 16 QAM	1@22	22.38	21.38	0.1374
48	30	10	646332	3694.98	DFT-s-OFDM 64 QAM	12@6	20.86	19.86	0.0967
48	30	10	646332	3694.98	DFT-s-OFDM 64 QAM	1@1	20.93	19.93	0.0984
48	30	10	646332	3694.98	DFT-s-OFDM 64 QAM	1@22	20.88	19.88	0.0972
48	30	10	646332	3694.98	DFT-s-OFDM 256 QAM	12@6	18.82	17.82	0.0605
48	30	10	646332	3694.98	DFT-s-OFDM 256 QAM	1@1	18.78	17.78	0.0600
48	30	10	646332	3694.98	DFT-s-OFDM 256 QAM	1@22	18.83	17.83	0.0606
48	30	10	646332	3694.98	CP-OFDM QPSK	12@6	21.95	20.95	0.1244
48	30	10	646332	3694.98	CP-OFDM QPSK	1@1	21.85	20.85	0.1216
48	30	10	646332	3694.98	CP-OFDM QPSK	1@22	21.91	20.91	0.1234
48	30	15	637168	3557.52	DFT-s-OFDM QPSK	1@1	18.16	17.16	0.0520
48	30	15	637168	3557.52	DFT-s-OFDM 16 QAM	1@1	17.06	16.06	0.0404
48	30	15	641666	3624.99	DFT-s-OFDM QPSK	1@1	23.30	22.30	0.1700
48	30	15	641666	3624.99	DFT-s-OFDM 16 QAM	1@1	22.55	21.55	0.1429
48	30	15	646166	3692.49	DFT-s-OFDM QPSK	1@1	23.47	22.47	0.1765
48	30	15	646166	3692.49	DFT-s-OFDM 16 QAM	1@1	22.58	21.58	0.1438
48	30	20	637334	3560.01	DFT-s-OFDM QPSK	1@1	16.65	15.65	0.0367
48	30	20	637334	3560.01	DFT-s-OFDM 16 QAM	1@1	16.15	15.15	0.0327
48	30	20	641666	3624.99	DFT-s-OFDM QPSK	1@1	23.28	22.28	0.1690
48	30	20	641666	3624.99	DFT-s-OFDM 16 QAM	1@1	22.46	21.46	0.1399
48	30	20	646000	3690	DFT-s-OFDM QPSK	1@1	23.39	22.39	0.1735
48	30	20	646000	3690	DFT-s-OFDM 16 QAM	1@1	22.50	21.50	0.1411
48	30	30	637668	3565.02	DFT-s-OFDM QPSK	36@18	11.89	10.89	0.0123
48	30	30	637668	3565.02	DFT-s-OFDM QPSK	1@1	11.65	10.65	0.0116
48	30	30	637668	3565.02	DFT-s-OFDM 16 QAM	36@18	11.45	10.45	0.0111
48	30	30	637668	3565.02	DFT-s-OFDM 16 QAM	1@1	11.34	10.34	0.0108
48	30	30	641666	3624.99	DFT-s-OFDM QPSK	36@18	23.32	22.32	0.1706
48	30	30	641666	3624.99	DFT-s-OFDM QPSK	1@1	18.52	17.52	0.0565
48	30	30	641666	3624.99	DFT-s-OFDM 16 QAM	36@18	22.16	21.16	0.1306
48	30	30	641666	3624.99	DFT-s-OFDM 16 QAM	1@1	18.25	17.25	0.0531
48	30	30	645666	3684.99	DFT-s-OFDM QPSK	36@18	12.22	11.22	0.0132
48	30	30	645666	3684.99	DFT-s-OFDM QPSK	1@1	12.06	11.06	0.0128
48	30	30	645666	3684.99	DFT-s-OFDM 16 QAM	36@18	11.81	10.81	0.0121
48	30	30	645666	3684.99	DFT-s-OFDM 16 QAM	1@1	11.79	10.79	0.0120
48	30	40	638000	3570	DFT-s-OFDM PI/2 BPSK	50@25	11.24	10.24	0.0106
48	30	40	638000	3570	DFT-s-OFDM PI/2 BPSK	1@1	11.16	10.16	0.0104
48	30	40	638000	3570	DFT-s-OFDM PI/2 BPSK	1@104	11.05	10.05	0.0101



48	30	40	638000	3570	DFT-s-OFDM QPSK	50@25	11.24	10.24	0.0106
48	30	40	638000	3570	DFT-s-OFDM QPSK	1@1	11.16	10.16	0.0104
48	30	40	638000	3570	DFT-s-OFDM QPSK	1@104	10.95	9.95	0.0099
48	30	40	638000	3570	DFT-s-OFDM 16 QAM	50@25	10.49	9.49	0.0089
48	30	40	638000	3570	DFT-s-OFDM 16 QAM	1@1	10.58	9.58	0.0091
48	30	40	638000	3570	DFT-s-OFDM 16 QAM	1@104	11.28	10.28	0.0107
48	30	40	638000	3570	DFT-s-OFDM 64 QAM	50@25	10.57	9.57	0.0091
48	30	40	638000	3570	DFT-s-OFDM 64 QAM	1@1	10.34	9.34	0.0086
48	30	40	638000	3570	DFT-s-OFDM 64 QAM	1@104	11.02	10.02	0.0101
48	30	40	638000	3570	DFT-s-OFDM 256 QAM	50@25	10.45	9.45	0.0088
48	30	40	638000	3570	DFT-s-OFDM 256 QAM	1@1	10.35	9.35	0.0086
48	30	40	638000	3570	DFT-s-OFDM 256 QAM	1@104	10.97	9.97	0.0099
48	30	40	638000	3570	CP-OFDM QPSK	53@26	10.58	9.58	0.0091
48	30	40	638000	3570	CP-OFDM QPSK	1@1	10.61	9.61	0.0091
48	30	40	638000	3570	CP-OFDM QPSK	1@104	10.55	9.55	0.0090
48	30	40	641666	3624.99	DFT-s-OFDM PI/2 BPSK	50@25	23.48	22.48	0.1771
48	30	40	641666	3624.99	DFT-s-OFDM PI/2 BPSK	1@1	18.22	17.22	0.0528
48	30	40	641666	3624.99	DFT-s-OFDM PI/2 BPSK	1@104	18.53	17.53	0.0567
48	30	40	641666	3624.99	DFT-s-OFDM QPSK	50@25	23.38	22.38	0.1728
48	30	40	641666	3624.99	DFT-s-OFDM QPSK	1@1	18.19	17.19	0.0524
48	30	40	641666	3624.99	DFT-s-OFDM QPSK	1@104	18.54	17.54	0.0567
48	30	40	641666	3624.99	DFT-s-OFDM 16 QAM	50@25	22.33	21.33	0.1359
48	30	40	641666	3624.99	DFT-s-OFDM 16 QAM	1@1	18.18	17.18	0.0522
48	30	40	641666	3624.99	DFT-s-OFDM 16 QAM	1@104	18.47	17.47	0.0559
48	30	40	641666	3624.99	DFT-s-OFDM 64 QAM	50@25	20.91	19.91	0.0979
48	30	40	641666	3624.99	DFT-s-OFDM 64 QAM	1@1	18.05	17.05	0.0507
48	30	40	641666	3624.99	DFT-s-OFDM 64 QAM	1@104	18.32	17.32	0.0540
48	30	40	641666	3624.99	DFT-s-OFDM 256 QAM	50@25	18.88	17.88	0.0613
48	30	40	641666	3624.99	DFT-s-OFDM 256 QAM	1@1	18.55	17.55	0.0568
48	30	40	641666	3624.99	DFT-s-OFDM 256 QAM	1@104	18.84	17.84	0.0608
48	30	40	641666	3624.99	CP-OFDM QPSK	53@26	21.85	20.85	0.1215
48	30	40	641666	3624.99	CP-OFDM QPSK	1@1	18.16	17.16	0.0520
48	30	40	641666	3624.99	CP-OFDM QPSK	1@104	18.53	17.53	0.0566
48	30	40	645332	3679.98	DFT-s-OFDM PI/2 BPSK	50@25	11.63	10.63	0.0116
48	30	40	645332	3679.98	DFT-s-OFDM PI/2 BPSK	1@1	11.47	10.47	0.0112
48	30	40	645332	3679.98	DFT-s-OFDM PI/2 BPSK	1@104	11.39	10.39	0.0109
48	30	40	645332	3679.98	DFT-s-OFDM QPSK	50@25	11.46	10.46	0.0111
48	30	40	645332	3679.98	DFT-s-OFDM QPSK	1@1	11.40	10.40	0.0110
48	30	40	645332	3679.98	DFT-s-OFDM QPSK	1@104	11.34	10.34	0.0108
48	30	40	645332	3679.98	DFT-s-OFDM 16 QAM	50@25	10.42	9.42	0.0087
48	30	40	645332	3679.98	DFT-s-OFDM 16 QAM	1@1	11.66	10.66	0.0116
48	30	40	645332	3679.98	DFT-s-OFDM 16 QAM	1@104	10.18	9.18	0.0083
48	30	40	645332	3679.98	DFT-s-OFDM 64 QAM	50@25	10.39	9.39	0.0087
48	30	40	645332	3679.98	DFT-s-OFDM 64 QAM	1@1	11.29	10.29	0.0107
48	30	40	645332	3679.98	DFT-s-OFDM 64 QAM	1@104	10.11	9.11	0.0081



---

48	30	40	645332	3679.98	DFT-s-OFDM 256 QAM	50@25	10.46	9.46	0.0088
48	30	40	645332	3679.98	DFT-s-OFDM 256 QAM	1@1	11.37	10.37	0.0109
48	30	40	645332	3679.98	DFT-s-OFDM 256 QAM	1@104	10.14	9.14	0.0082
48	30	40	645332	3679.98	CP-OFDM QPSK	53@26	10.94	9.94	0.0099
48	30	40	645332	3679.98	CP-OFDM QPSK	1@1	10.91	9.91	0.0098
48	30	40	645332	3679.98	CP-OFDM QPSK	1@104	10.78	9.78	0.0095



### Frequency Stability

NR Band	SCS (kHz)	Bandwidth (MHz)	Arfcn	Freq (MHz)	Modulation	RB	Deviation (ppm)	Verdict	Environment
48	30	20	641666	3624.99	DFT-s-OFDM QPSK	50@0	0.0029	PASS	NV
48	30	20	641666	3624.99	DFT-s-OFDM QPSK	50@0	0.0025	PASS	LV
48	30	20	641666	3624.99	DFT-s-OFDM QPSK	50@0	0.0066	PASS	HV
48	30	20	641666	3624.99	DFT-s-OFDM QPSK	50@0	0.0065	PASS	-30°C
48	30	20	641666	3624.99	DFT-s-OFDM QPSK	50@0	0.0034	PASS	-20°C
48	30	20	641666	3624.99	DFT-s-OFDM QPSK	50@0	0.0028	PASS	-10°C
48	30	20	641666	3624.99	DFT-s-OFDM QPSK	50@0	0.0031	PASS	0°C
48	30	20	641666	3624.99	DFT-s-OFDM QPSK	50@0	0.0036	PASS	10°C
48	30	20	641666	3624.99	DFT-s-OFDM QPSK	50@0	0.0029	PASS	20°C
48	30	20	641666	3624.99	DFT-s-OFDM QPSK	50@0	0.0069	PASS	30°C
48	30	20	641666	3624.99	DFT-s-OFDM QPSK	50@0	0.0026	PASS	40°C
48	30	20	641666	3624.99	DFT-s-OFDM QPSK	50@0	0.0067	PASS	50°C



### Peak to Average Ratio

NR Band	SCS (kHz)	Bandwidth (MHz)	Arfcn	Freq (MHz)	Modulation	RB	Result (dB)	Limit (dB)	Verdict
48	30	20	641666	3624.99	DFT-s-OFDM PI/2 BPSK	50@0	3.67	13	PASS
48	30	20	641666	3624.99	DFT-s-OFDM QPSK	50@0	4.44	13	PASS

N48(20M)\_DFT-s-OFDM\_PI\_2-BPSK\_Outer\_Full\_Mid\_CH

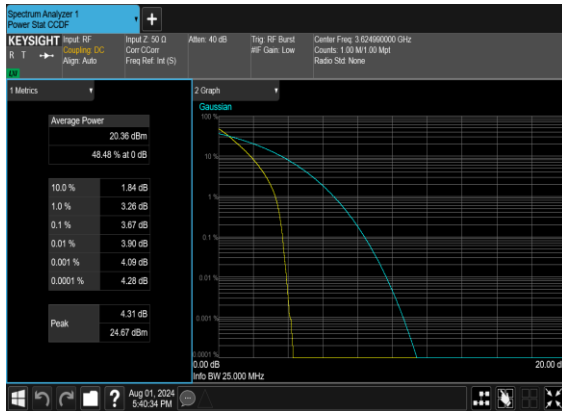

N48(20M)\_DFT-s-OFDM\_QPSK\_Outer\_Full\_Mid\_CH





### Occupied Bandwidth

NR Band	SCS (kHz)	Bandwidth (MHz)	Arfcn	Freq (MHz)	Modulation	RB	OBW (MHz)	26dB BW (MHz)
48	30	10	641666	3624.99	CP-OFDM QPSK	24@0	8.5823	9.853
48	30	10	641666	3624.99	CP-OFDM 16 QAM	24@0	8.5788	9.437
48	30	10	641666	3624.99	CP-OFDM 64 QAM	24@0	8.5759	9.728
48	30	10	641666	3624.99	CP-OFDM 256 QAM	24@0	8.5651	9.589
48	30	15	641666	3624.99	CP-OFDM QPSK	38@0	13.602	14.54
48	30	15	641666	3624.99	CP-OFDM 16 QAM	38@0	13.591	14.66
48	30	15	641666	3624.99	CP-OFDM 64 QAM	38@0	13.572	14.33
48	30	15	641666	3624.99	CP-OFDM 256 QAM	38@0	13.568	14.63
48	30	20	641666	3624.99	CP-OFDM QPSK	51@0	18.257	19.5
48	30	20	641666	3624.99	CP-OFDM 16 QAM	51@0	18.216	19.48
48	30	20	641666	3624.99	CP-OFDM 64 QAM	51@0	18.252	19.65
48	30	20	641666	3624.99	CP-OFDM 256 QAM	51@0	18.219	19.54
48	30	30	641666	3624.99	CP-OFDM QPSK	78@0	27.838	28.77
48	30	30	641666	3624.99	CP-OFDM 16 QAM	78@0	27.815	28.98
48	30	30	641666	3624.99	CP-OFDM 64 QAM	78@0	27.783	29.34
48	30	30	641666	3624.99	CP-OFDM 256 QAM	78@0	27.836	29.28
48	30	40	641666	3624.99	CP-OFDM QPSK	106@0	37.774	39.39
48	30	40	641666	3624.99	CP-OFDM 16 QAM	106@0	37.821	39.11
48	30	40	641666	3624.99	CP-OFDM 64 QAM	106@0	37.803	39.47
48	30	40	641666	3624.99	CP-OFDM 256 QAM	106@0	37.827	39.47



N48(10M)\_CP-OFDM\_QPSK\_Outer\_Full\_Mid\_CH

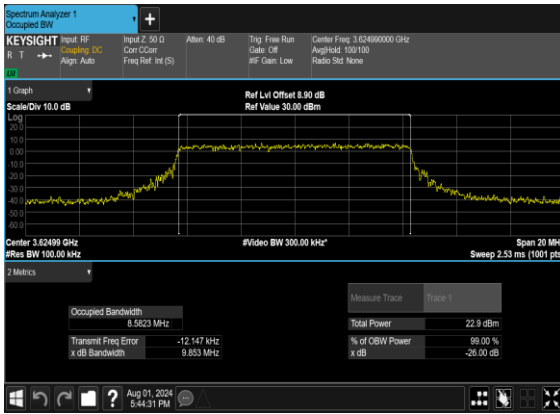

N48(10M)\_CP-OFDM\_16QAM\_Outer\_Full\_Mid\_CH

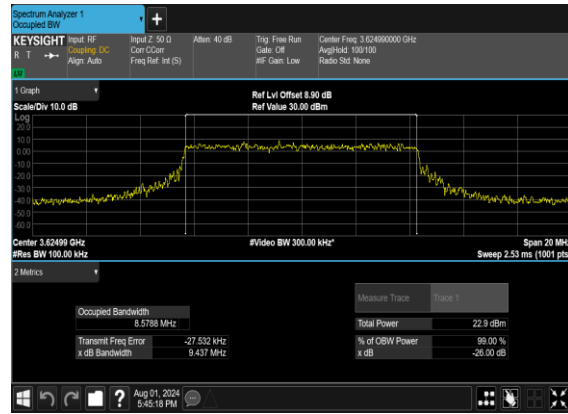

N48(10M)\_CP-OFDM\_64QAM\_Outer\_Full\_Mid\_CH



N48(10M)\_CP-OFDM\_256QAM\_Outer\_Full\_Mid\_CH

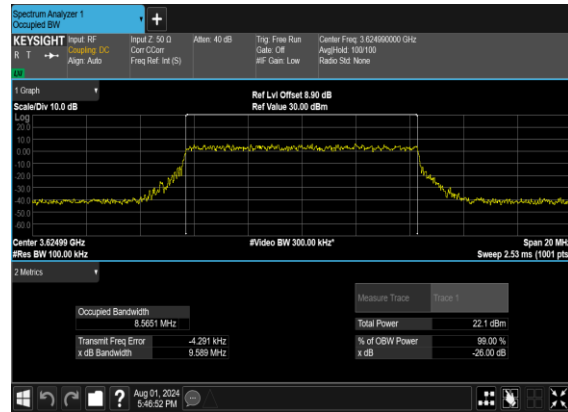





N48(15M)\_CP-OFDM\_QPSK\_Outer\_Full\_Mid\_CH

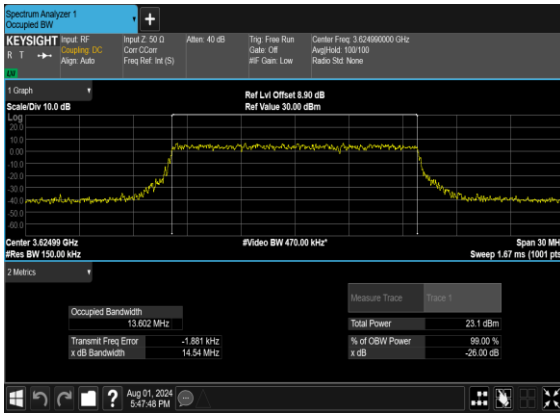

N48(15M)\_CP-OFDM\_16QAM\_Outer\_Full\_Mid\_CH

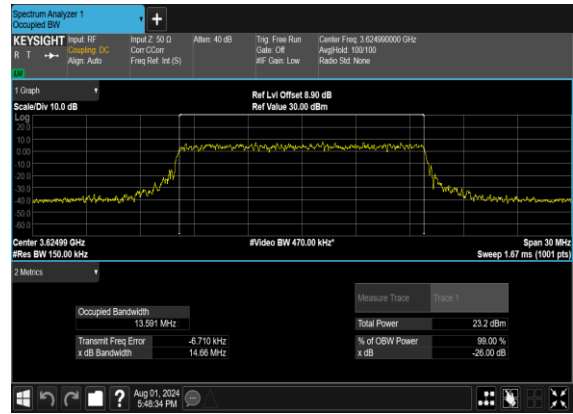

N48(15M)\_CP-OFDM\_64QAM\_Outer\_Full\_Mid\_CH

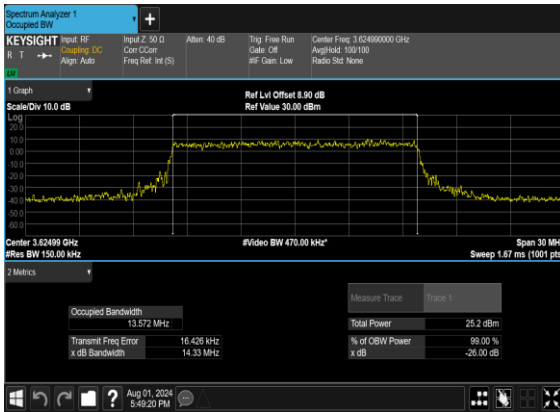

N48(15M)\_CP-OFDM\_256QAM\_Outer\_Full\_Mid\_CH





N48(20M)\_CP-OFDM\_QPSK\_Outer\_Full\_Mid\_CH

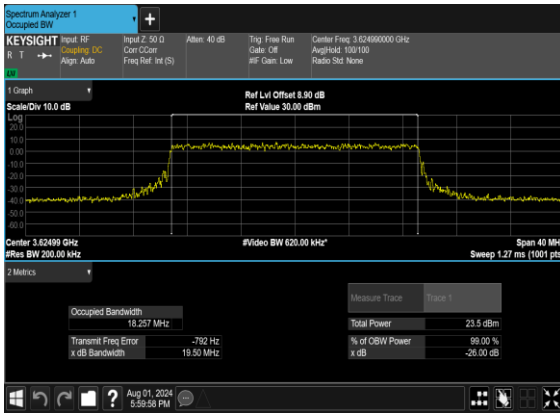

N48(20M)\_CP-OFDM\_16 QAM\_Outer\_Full\_Mid\_CH

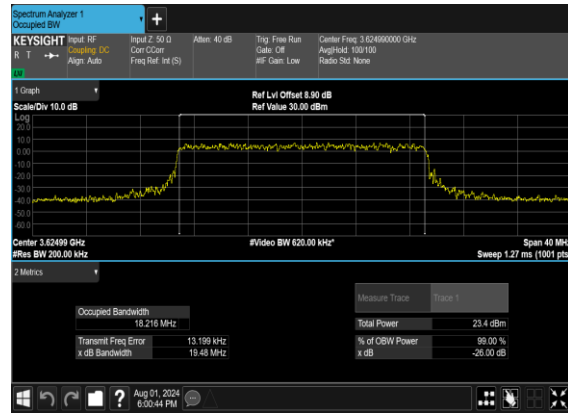

N48(20M)\_CP-OFDM\_64 QAM\_Outer\_Full\_Mid\_CH

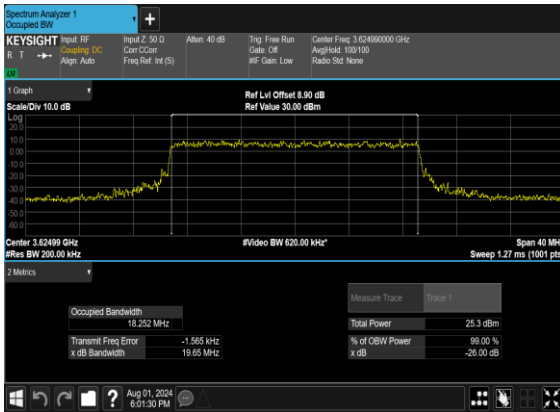

N48(20M)\_CP-OFDM\_256 QAM\_Outer\_Full\_Mid\_CH

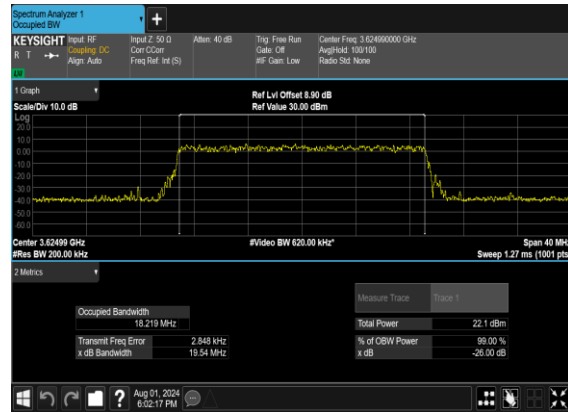



N48(30M)\_CP-OFDM\_QPSK\_Outer\_Full\_Mid\_CH



N48(30M)\_CP-OFDM\_16QAM\_Outer\_Full\_Mid\_CH

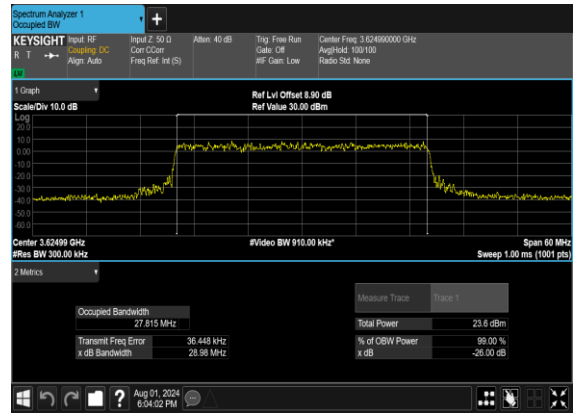

N48(30M)\_CP-OFDM\_64QAM\_Outer\_Full\_Mid\_CH

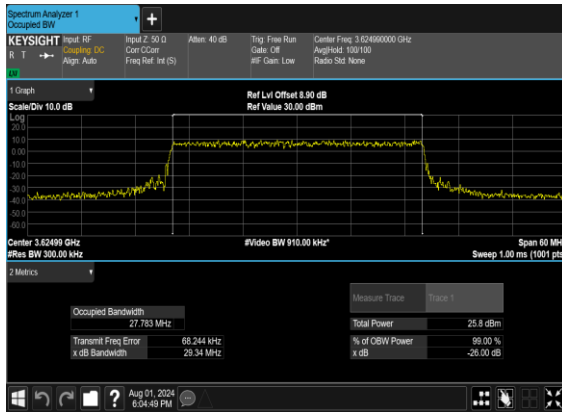

N48(30M)\_CP-OFDM\_256QAM\_Outer\_Full\_Mid\_CH

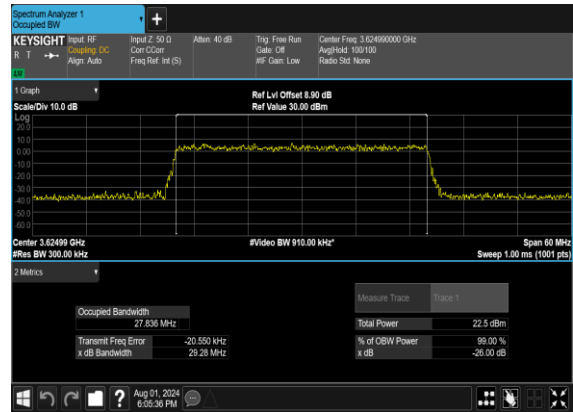



N48(40M)\_CP-OFDM\_QPSK\_Outer\_Full\_Mid\_CH



N48(40M)\_CP-OFDM\_16QAM\_Outer\_Full\_Mid\_CH

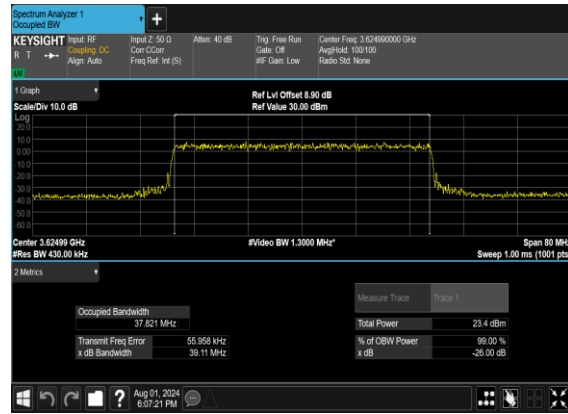

N48(40M)\_CP-OFDM\_64QAM\_Outer\_Full\_Mid\_CH

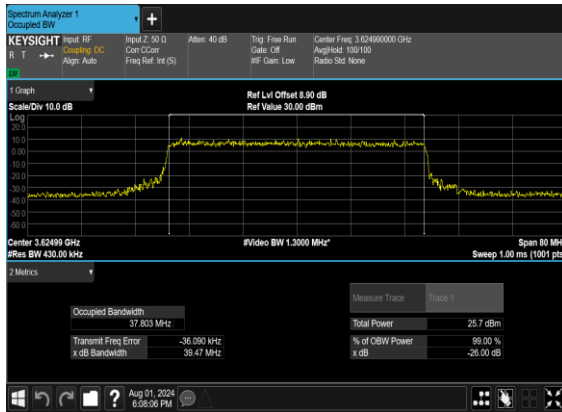

N48(40M)\_CP-OFDM\_256QAM\_Outer\_Full\_Mid\_CH

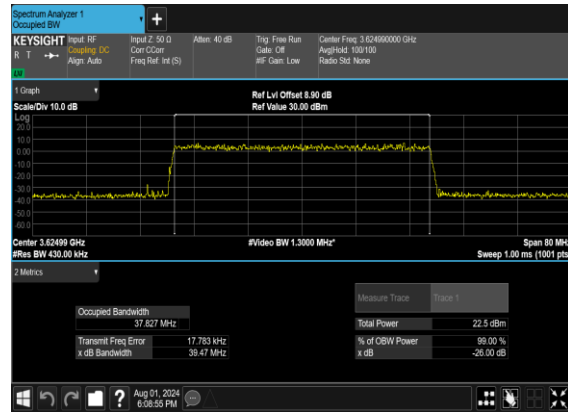



### Adjacent Channel Leakage Ratio

NR Band	SCS (kHz)	Bandwidth (MHz)	Arfcn	Freq (MHz)	Modulation	RB	Lower Margin	Upper Margin	Result	Verdict
48	30	10	637000	3555.0	DFT-s-OFDM PI/2 BPSK	24@0	-14.02	-13.59	see graph	PASS
48	30	10	637000	3555.0	DFT-s-OFDM PI/2 BPSK	1@0	-11.0	-19.7	see graph	PASS
48	30	10	637000	3555.0	DFT-s-OFDM PI/2 BPSK	1@23	-25.59	-12.33	see graph	PASS
48	30	10	637000	3555.0	DFT-s-OFDM QPSK	24@0	-14.96	-14.4	see graph	PASS
48	30	10	637000	3555.0	DFT-s-OFDM QPSK	1@0	-10.34	-24.95	see graph	PASS
48	30	10	637000	3555.0	DFT-s-OFDM QPSK	1@23	-25.2	-11.89	see graph	PASS
48	30	10	641666	3624.99	DFT-s-OFDM PI/2 BPSK	24@0	-14.47	-15.34	see graph	PASS
48	30	10	641666	3624.99	DFT-s-OFDM PI/2 BPSK	1@0	-10.57	-23.45	see graph	PASS
48	30	10	641666	3624.99	DFT-s-OFDM PI/2 BPSK	1@23	-21.93	-12.41	see graph	PASS
48	30	10	641666	3624.99	DFT-s-OFDM QPSK	24@0	-17.41	-13.19	see graph	PASS
48	30	10	641666	3624.99	DFT-s-OFDM QPSK	1@0	-9.04	-22.55	see graph	PASS
48	30	10	641666	3624.99	DFT-s-OFDM QPSK	1@23	-22.03	-10.75	see graph	PASS
48	30	10	646332	3694.98	DFT-s-OFDM PI/2 BPSK	24@0	-14.55	-14.56	see graph	PASS
48	30	10	646332	3694.98	DFT-s-OFDM PI/2 BPSK	1@0	-9.86	-22.26	see graph	PASS
48	30	10	646332	3694.98	DFT-s-OFDM PI/2 BPSK	1@23	-23.33	-12.05	see graph	PASS
48	30	10	646332	3694.98	DFT-s-OFDM QPSK	24@0	-14.58	-14.34	see graph	PASS
48	30	10	646332	3694.98	DFT-s-OFDM QPSK	1@0	-10.15	-22.07	see graph	PASS
48	30	10	646332	3694.98	DFT-s-OFDM QPSK	1@23	-21.67	-10.29	see graph	PASS
48	30	20	637334	3560.01	DFT-s-OFDM PI/2 BPSK	50@0	-16.07	-17.64	see graph	PASS
48	30	20	637334	3560.01	DFT-s-OFDM PI/2 BPSK	1@0	-11.28	-18.28	see graph	PASS
48	30	20	637334	3560.01	DFT-s-OFDM PI/2 BPSK	1@50	-22.08	-13.27	see graph	PASS
48	30	20	637334	3560.01	DFT-s-OFDM QPSK	50@0	-16.19	-17.17	see graph	PASS
48	30	20	637334	3560.01	DFT-s-OFDM QPSK	1@0	-12.7	-20.19	see graph	PASS
48	30	20	637334	3560.01	DFT-s-OFDM QPSK	1@50	-22.47	-12.72	see graph	PASS
48	30	20	641666	3624.99	DFT-s-OFDM PI/2 BPSK	50@0	-16.15	-16.98	see graph	PASS
48	30	20	641666	3624.99	DFT-s-OFDM PI/2 BPSK	1@0	-12.16	-20.63	see graph	PASS
48	30	20	641666	3624.99	DFT-s-OFDM PI/2 BPSK	1@50	-20.94	-13.2	see graph	PASS
48	30	20	641666	3624.99	DFT-s-OFDM QPSK	50@0	-15.96	-16.7	see graph	PASS
48	30	20	641666	3624.99	DFT-s-OFDM	1@0	-10.43	-19.78	see graph	PASS



					QPSK					
48	30	20	641666	3624.99	DFT-s-OFDM QPSK	1@50	-20.78	-12.39	see graph	PASS
48	30	20	646000	3690.0	DFT-s-OFDM PI/2 BPSK	50@0	-15.13	-15.06	see graph	PASS
48	30	20	646000	3690.0	DFT-s-OFDM PI/2 BPSK	1@0	-11.46	-19.47	see graph	PASS
48	30	20	646000	3690.0	DFT-s-OFDM PI/2 BPSK	1@50	-18.83	-13.11	see graph	PASS
48	30	20	646000	3690.0	DFT-s-OFDM QPSK	50@0	-14.45	-14.97	see graph	PASS
48	30	20	646000	3690.0	DFT-s-OFDM QPSK	1@0	-11.32	-19.37	see graph	PASS
48	30	20	646000	3690.0	DFT-s-OFDM QPSK	1@50	-17.8	-12.42	see graph	PASS
48	30	40	638000	3570.0	DFT-s-OFDM PI/2 BPSK	100@0	-8.35	-8.08	see graph	PASS
48	30	40	638000	3570.0	DFT-s-OFDM PI/2 BPSK	1@0	-8.19	-8.64	see graph	PASS
48	30	40	638000	3570.0	DFT-s-OFDM PI/2 BPSK	1@105	-8.58	-7.42	see graph	PASS
48	30	40	638000	3570.0	DFT-s-OFDM QPSK	100@0	-7.72	-7.69	see graph	PASS
48	30	40	638000	3570.0	DFT-s-OFDM QPSK	1@0	-8.11	-8.42	see graph	PASS
48	30	40	638000	3570.0	DFT-s-OFDM QPSK	1@105	-8.76	-7.49	see graph	PASS
48	30	40	641666	3624.99	DFT-s-OFDM PI/2 BPSK	100@0	-13.73	-12.75	see graph	PASS
48	30	40	641666	3624.99	DFT-s-OFDM PI/2 BPSK	1@0	-12.84	-16.09	see graph	PASS
48	30	40	641666	3624.99	DFT-s-OFDM PI/2 BPSK	1@105	-15.04	-12.15	see graph	PASS
48	30	40	641666	3624.99	DFT-s-OFDM QPSK	100@0	-13.81	-13.29	see graph	PASS
48	30	40	641666	3624.99	DFT-s-OFDM QPSK	1@0	-11.95	-14.62	see graph	PASS
48	30	40	641666	3624.99	DFT-s-OFDM QPSK	1@105	-16.69	-13.36	see graph	PASS
48	30	40	645332	3679.98	DFT-s-OFDM PI/2 BPSK	100@0	-7.96	-7.36	see graph	PASS
48	30	40	645332	3679.98	DFT-s-OFDM PI/2 BPSK	1@0	-7.24	-7.27	see graph	PASS
48	30	40	645332	3679.98	DFT-s-OFDM PI/2 BPSK	1@105	-7.99	-6.5	see graph	PASS
48	30	40	645332	3679.98	DFT-s-OFDM QPSK	100@0	-7.56	-7.07	see graph	PASS
48	30	40	645332	3679.98	DFT-s-OFDM QPSK	1@0	-7.66	-7.59	see graph	PASS
48	30	40	645332	3679.98	DFT-s-OFDM QPSK	1@105	-8.13	-6.67	see graph	PASS



N48(10M)\_DFT-s-OFDM\_PI\_2-BPSK\_Outer\_Full\_Low\_CH

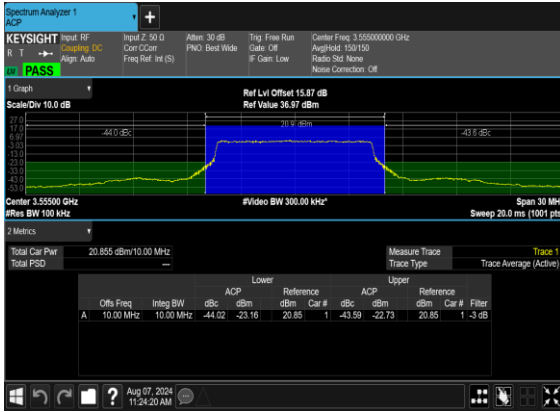

N48(10M)\_DFT-s-OFDM\_PI\_2-BPSK\_Edge\_1RB\_Left\_Low\_CH

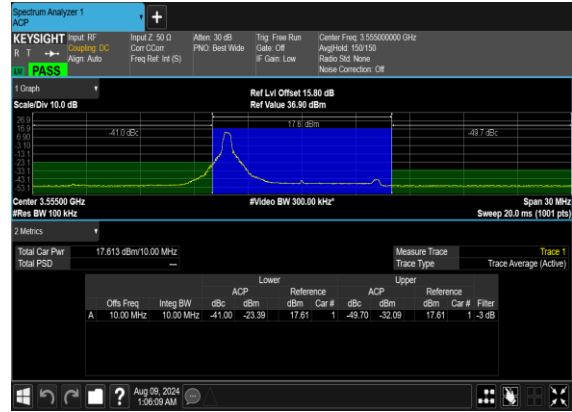

N48(10M)\_DFT-s-OFDM\_PI\_2-BPSK\_Edge\_1RB\_Right\_Low\_CH

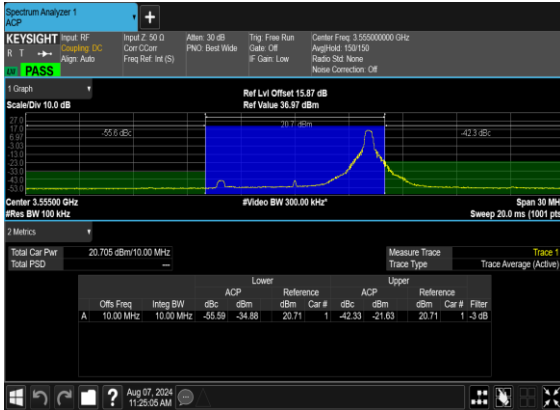

N48(10M)\_DFT-s-OFDM\_QPSK\_Outer\_Full\_Low\_CH

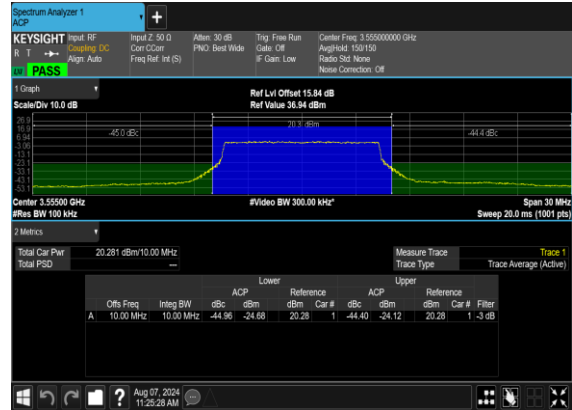



N48(10M)\_DFT-s-OFDM\_QPSK\_Edge\_1RB\_Left\_Low\_CH

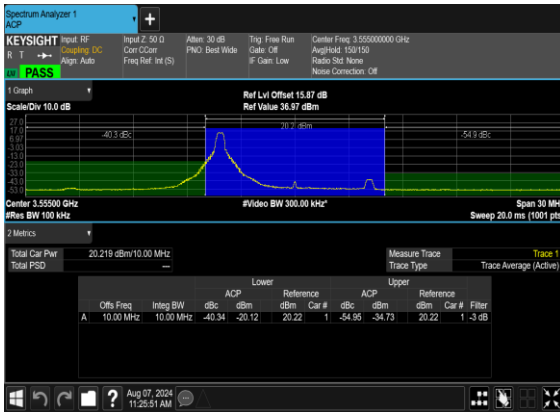

N48(10M)\_DFT-s-OFDM\_QPSK\_Edge\_1RB\_Right\_Low\_CH

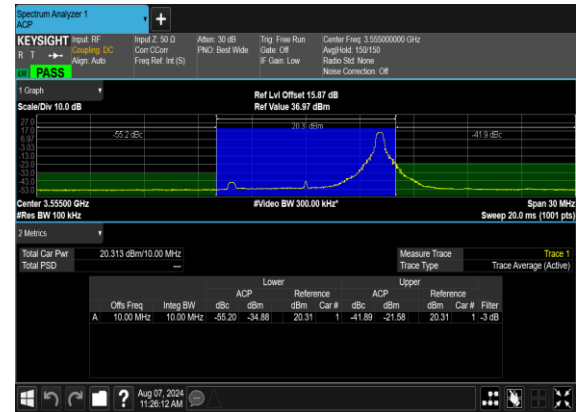

N48(10M)\_DFT-s-OFDM\_PI\_2-BPSK\_Outer\_Full\_Mid\_CH

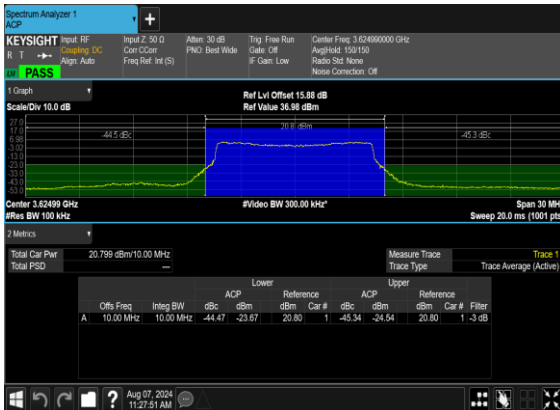

N48(10M)\_DFT-s-OFDM\_PI\_2-BPSK\_Edge\_1RB\_Left\_Mid\_CH

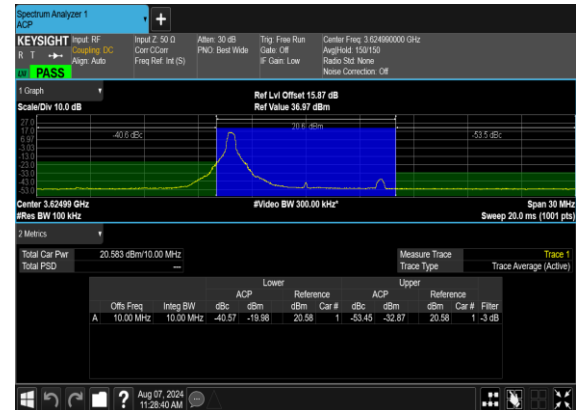





N48(10M)\_DFT-s-OFDM\_PI\_2-BPSK\_Edge\_1RB\_Right\_Mid\_CH

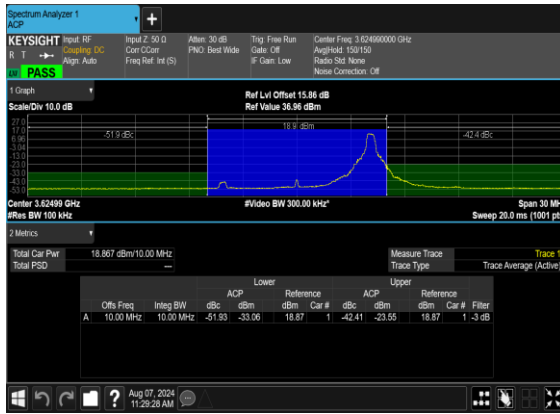

N48(10M)\_DFT-s-OFDM\_QPSK\_Outer\_Full\_Mid\_CH

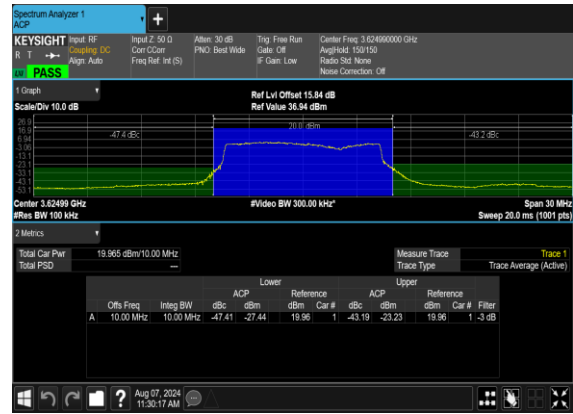

N48(10M)\_DFT-s-OFDM\_QPSK\_Edge\_1RB\_Left\_Mid\_CH

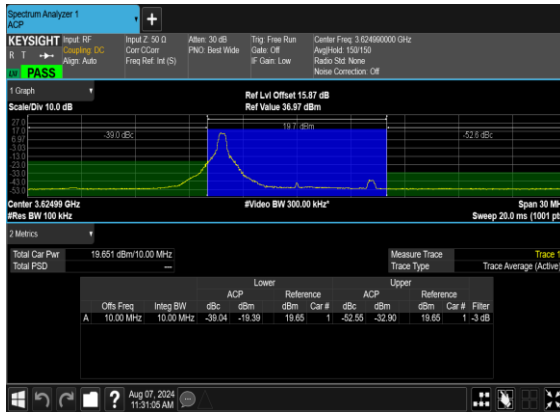

N48(10M)\_DFT-s-OFDM\_QPSK\_Edge\_1RB\_Right\_Mid\_CH

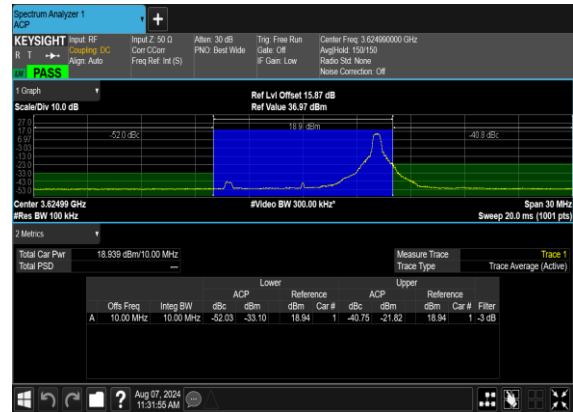



N48(10M)\_DFT-s-OFDM\_PI\_2-BPSK\_Outer\_Full\_High\_CH

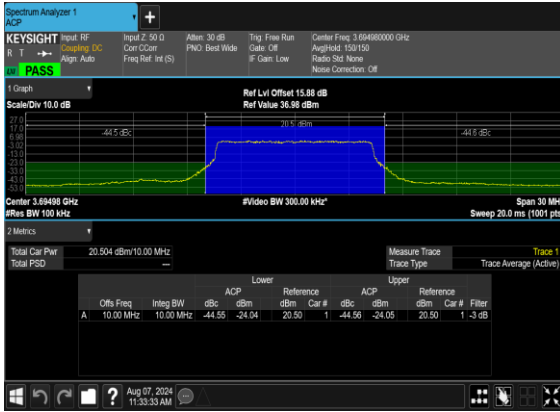

N48(10M)\_DFT-s-OFDM\_PI\_2-BPSK\_Edge\_1RB\_Left\_High\_CH

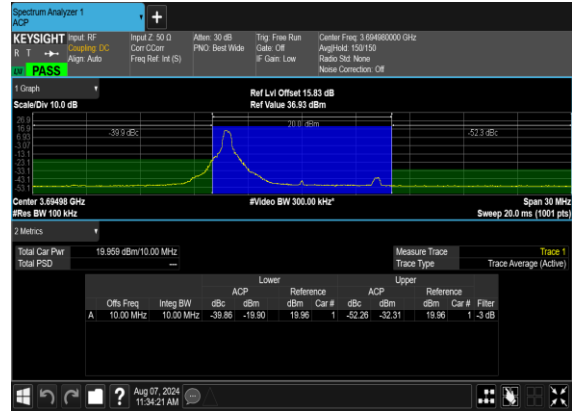

N48(10M)\_DFT-s-OFDM\_PI\_2-BPSK\_Edge\_1RB\_Right\_High\_CH

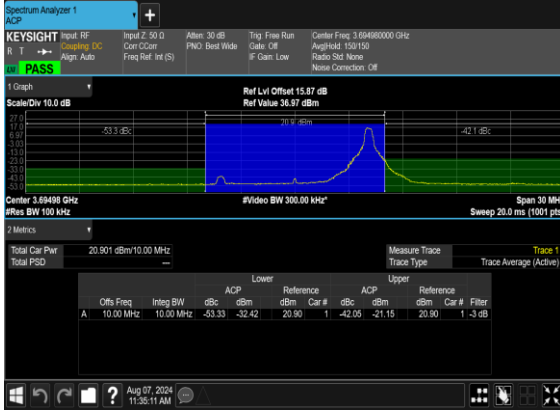

N48(10M)\_DFT-s-OFDM\_QPSK\_Outer\_Full\_High\_CH

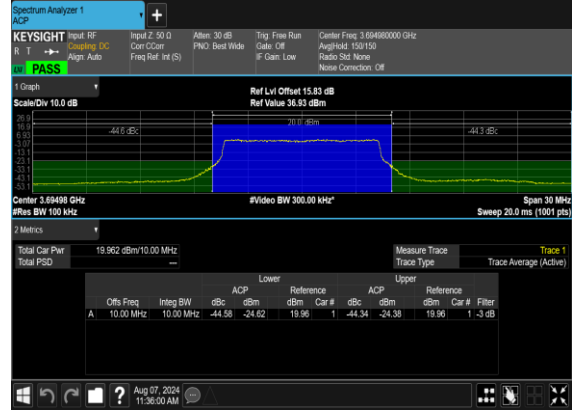



N48(10M)\_DFT-s-OFDM\_QPSK\_Edge\_1RB\_Left\_High\_CH

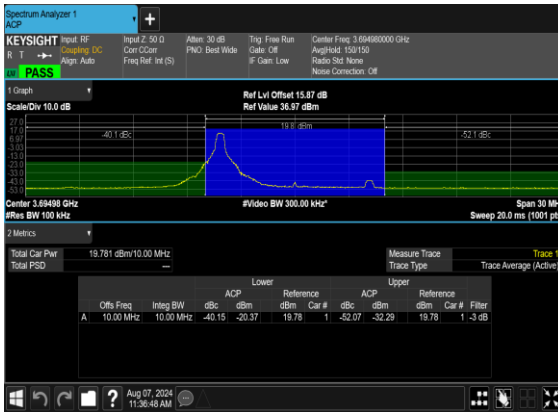

N48(10M)\_DFT-s-OFDM\_QPSK\_Edge\_1RB\_Right\_High\_CH

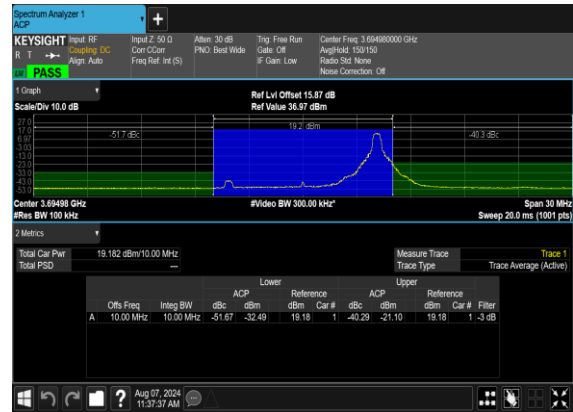

N48(20M)\_DFT-s-OFDM\_PI\_2-BPSK\_Outer\_Full\_Low\_CH

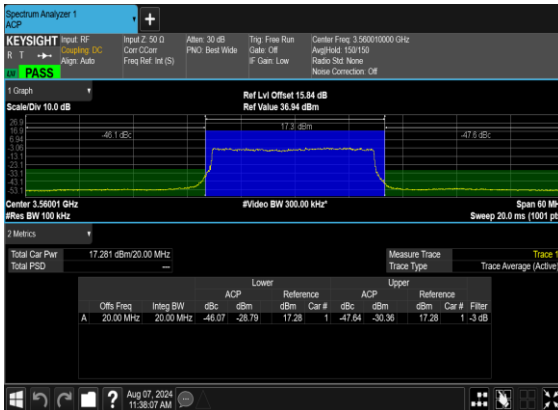

N48(20M)\_DFT-s-OFDM\_PI\_2-BPSK\_Edge\_1RB\_Left\_Low\_CH

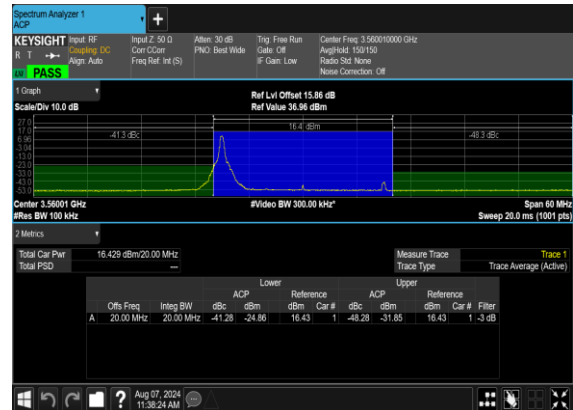



N48(20M)\_DFT-s-OFDM\_PI\_2-BPSK\_Edge\_1RB\_Right\_Low\_CH



N48(20M)\_DFT-s-OFDM\_QPSK\_Outer\_Full\_Low\_CH

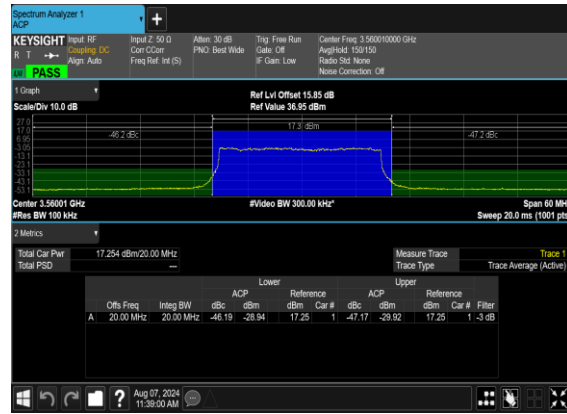

N48(20M)\_DFT-s-OFDM\_QPSK\_Edge\_1RB\_Left\_Low\_CH

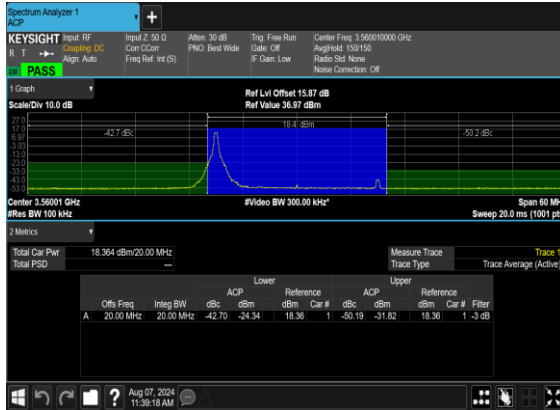

N48(20M)\_DFT-s-OFDM\_QPSK\_Edge\_1RB\_Right\_Low\_CH





N48(20M)\_DFT-s-OFDM\_PI\_2-BPSK\_Outer\_Full\_Mid\_CH

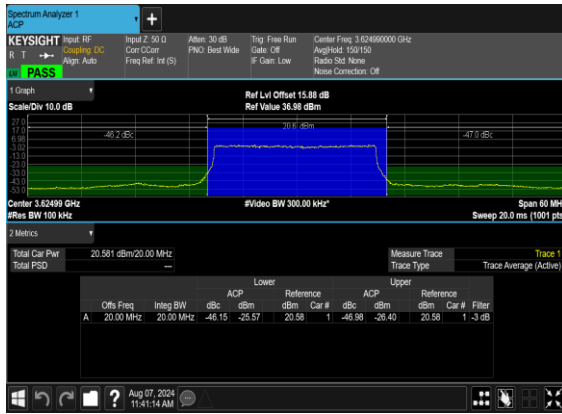

N48(20M)\_DFT-s-OFDM\_PI\_2-BPSK\_Edge\_1RB\_Left\_Mid\_CH

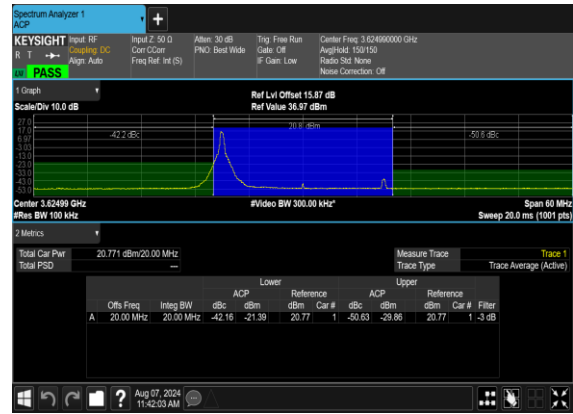

N48(20M)\_DFT-s-OFDM\_PI\_2-BPSK\_Edge\_1RB\_Right\_Mid\_CH



N48(20M)\_DFT-s-OFDM\_QPSK\_Outer\_Full\_Mid\_CH

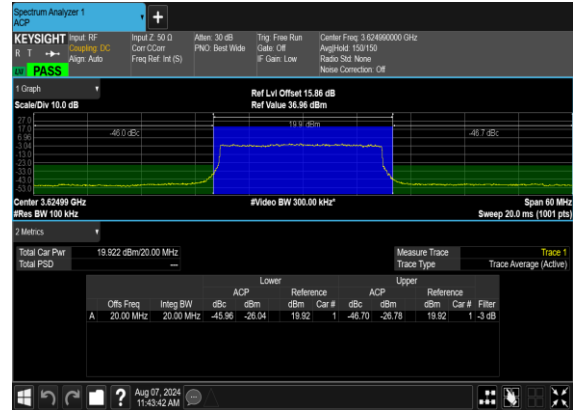



N48(20M)\_DFT-s-OFDM\_QPSK\_Edge\_1RB\_Left\_Mid\_CH

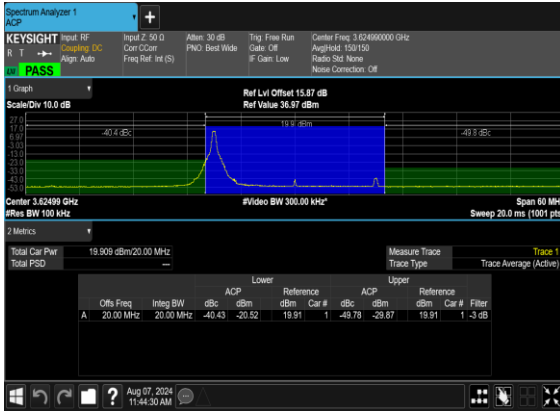

N48(20M)\_DFT-s-OFDM\_QPSK\_Edge\_1RB\_Right\_Mid\_CH

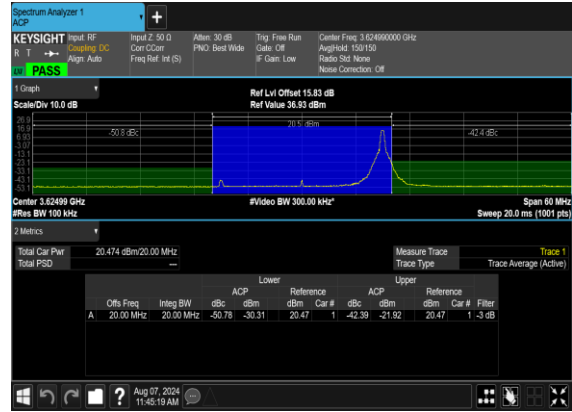

N48(20M)\_DFT-s-OFDM\_PI\_2-BPSK\_Outer\_Full\_High\_CH

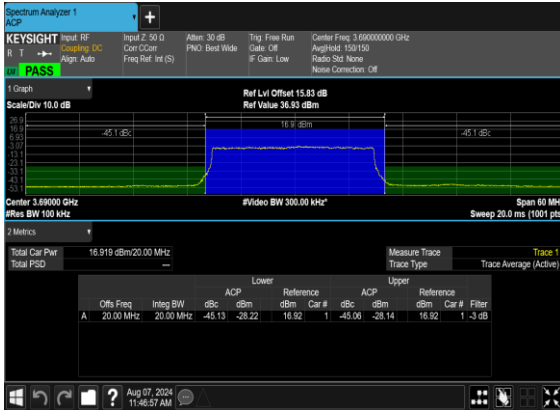

N48(20M)\_DFT-s-OFDM\_PI\_2-BPSK\_Edge\_1RB\_Left\_High\_CH

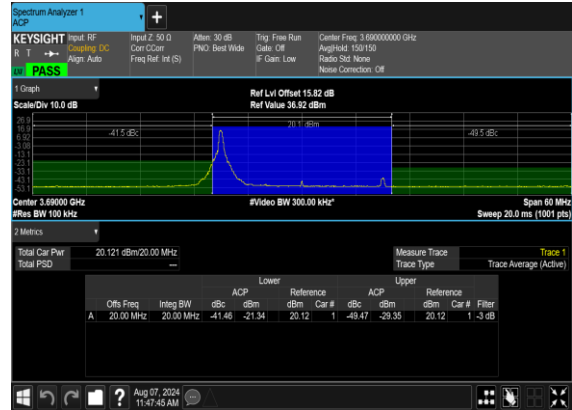



N48(20M)\_DFT-s-OFDM\_PI\_2-BPSK\_Edge\_1RB\_Right\_High\_CH

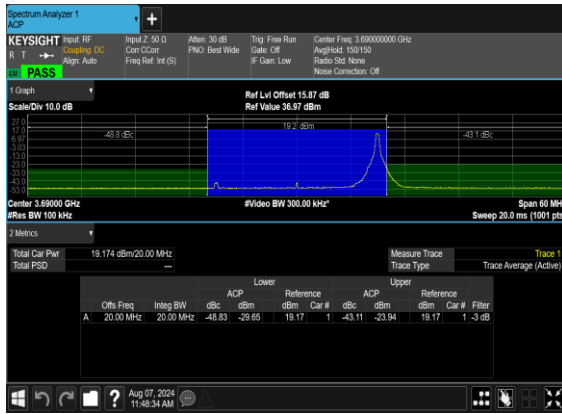

N48(20M)\_DFT-s-OFDM\_QPSK\_Outer\_Full\_High\_CH

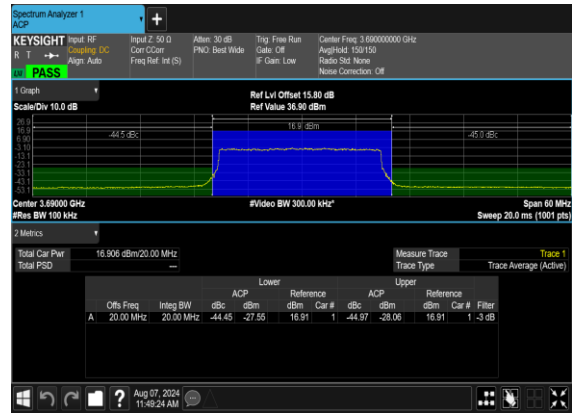

N48(20M)\_DFT-s-OFDM\_QPSK\_Edge\_1RB\_Left\_High\_CH

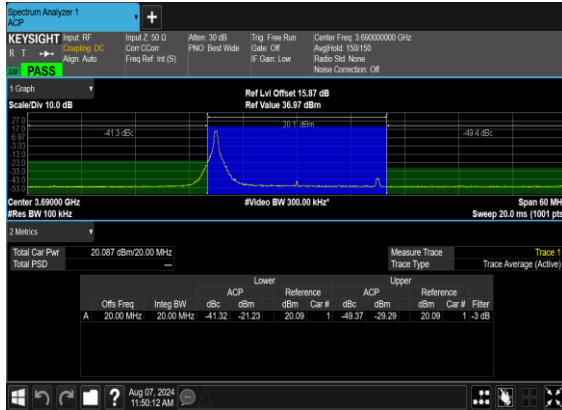

N48(20M)\_DFT-s-OFDM\_QPSK\_Edge\_1RB\_Right\_High\_CH

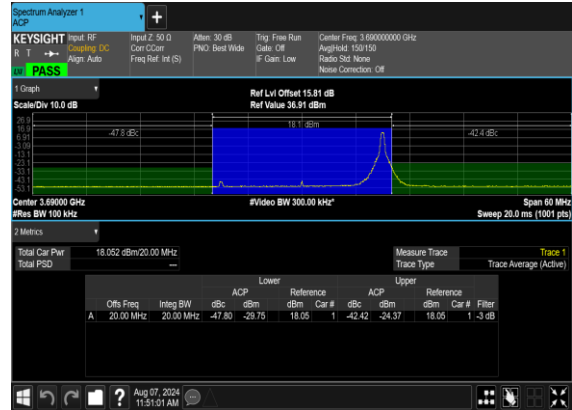



N48(40M)\_DFT-s-OFDM\_PI\_2-BPSK\_Outer\_Full\_Low\_CH

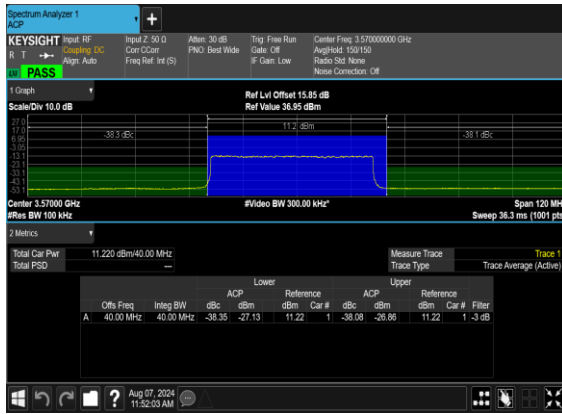

N48(40M)\_DFT-s-OFDM\_PI\_2-BPSK\_Edge\_1RB\_Left\_Low\_CH

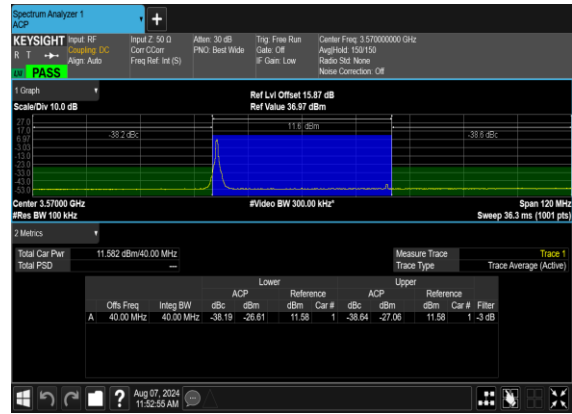

N48(40M)\_DFT-s-OFDM\_PI\_2-BPSK\_Edge\_1RB\_Right\_Low\_CH

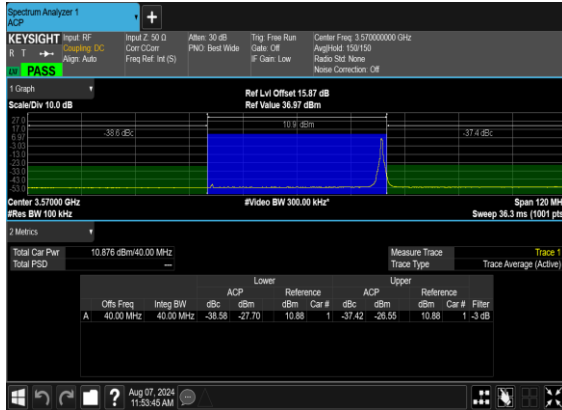

N48(40M)\_DFT-s-OFDM\_QPSK\_Outer\_Full\_Low\_CH

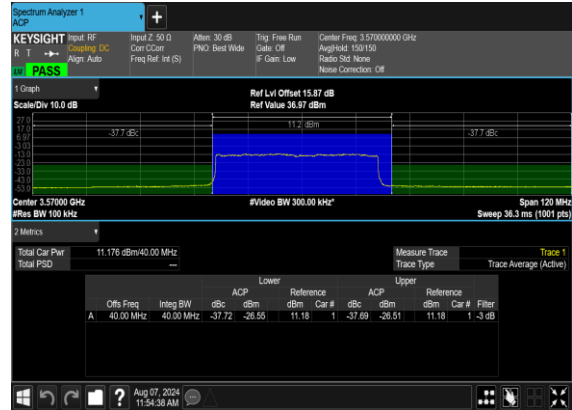





N48(40M)\_DFT-s-OFDM\_QPSK\_Edge\_1RB\_Left\_Low\_CH

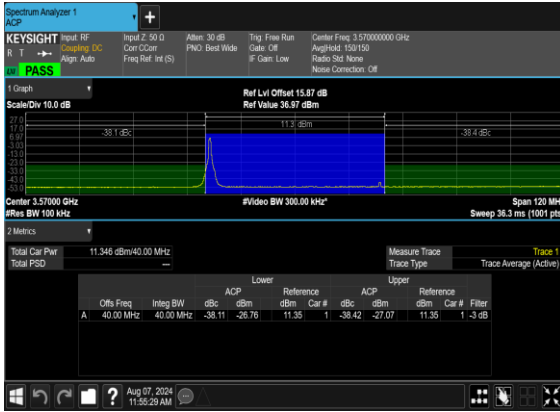

N48(40M)\_DFT-s-OFDM\_QPSK\_Edge\_1RB\_Right\_Low\_CH



N48(40M)\_DFT-s-OFDM\_PI\_2-BPSK\_Outer\_Full\_Mid\_CH

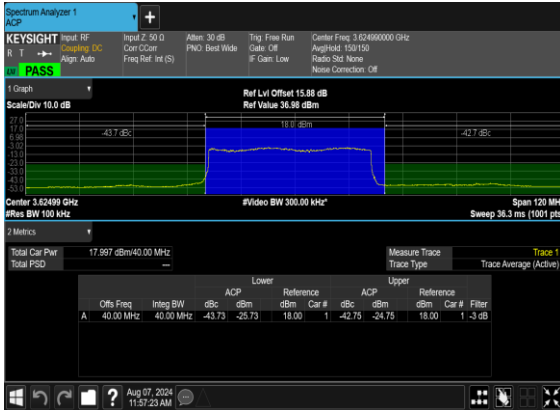

N48(40M)\_DFT-s-OFDM\_PI\_2-BPSK\_Edge\_1RB\_Left\_Mid\_CH

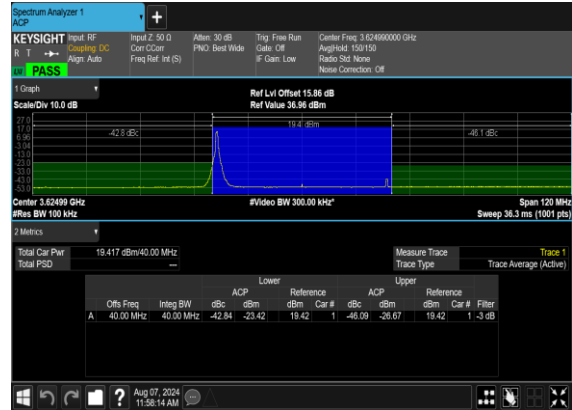



N48(40M)\_DFT-s-OFDM\_PI\_2-BPSK\_Edge\_1RB\_Right\_Mid\_CH



N48(40M)\_DFT-s-OFDM\_QPSK\_Outer\_Full\_Mid\_CH

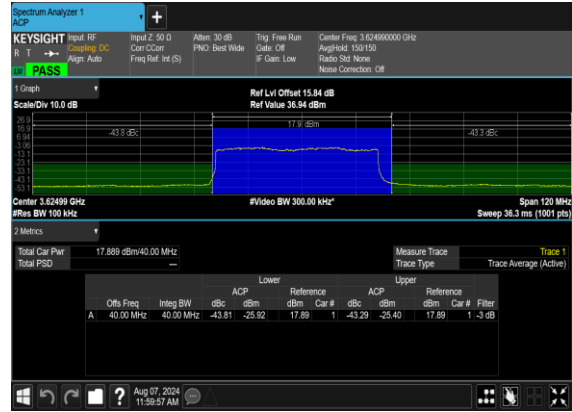

N48(40M)\_DFT-s-OFDM\_QPSK\_Edge\_1RB\_Left\_Mid\_CH



N48(40M)\_DFT-s-OFDM\_QPSK\_Edge\_1RB\_Right\_Mid\_CH





N48(40M)\_DFT-s-OFDM\_PI\_2-BPSK\_Outer\_Full\_High\_CH

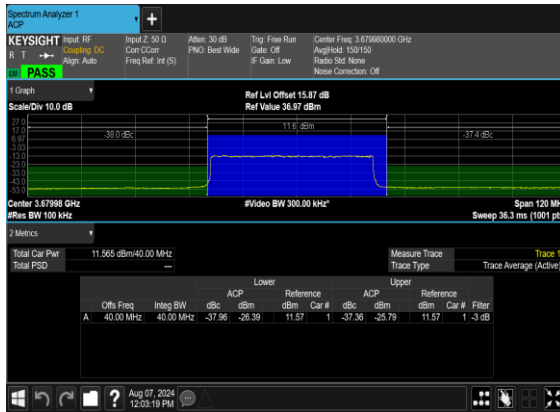

N48(40M)\_DFT-s-OFDM\_PI\_2-BPSK\_Edge\_1RB\_Left\_High\_CH



N48(40M)\_DFT-s-OFDM\_PI\_2-BPSK\_Edge\_1RB\_Right\_High\_CH



N48(40M)\_DFT-s-OFDM\_QPSK\_Outer\_Full\_High\_CH

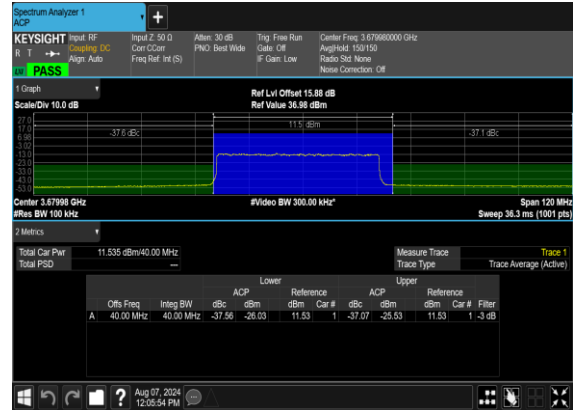



N48(40M)\_DFT-s-OFDM\_QPSK\_Edge\_1RB\_Left\_High\_CH



N48(40M)\_DFT-s-OFDM\_QPSK\_Edge\_1RB\_Right\_High\_CH

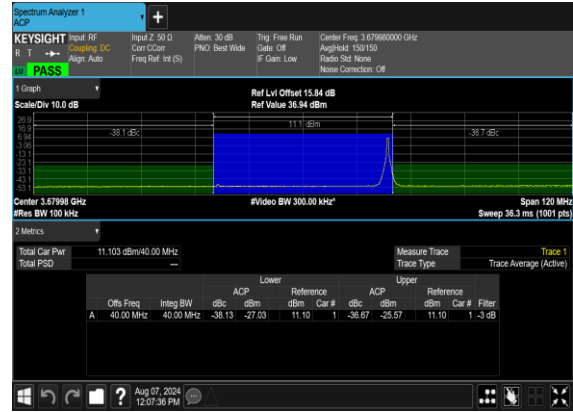



### Conducted Spurious Emissions

NR Band	SCS (kHz)	Bandwidth (MHz)	Arfcn	Freq (MHz)	Modulation	RB	Result	Verdict
48	30	10	637000	3555.0	DFT-s-OFDM BPSK	1@0	see graph	---
48	30	10	637000	3555.0	DFT-s-OFDM BPSK	1@0	see graph	PASS
48	30	10	637000	3555.0	DFT-s-OFDM BPSK	1@0	see graph	PASS
48	30	10	637000	3555.0	DFT-s-OFDM QPSK	1@0	see graph	---
48	30	10	637000	3555.0	DFT-s-OFDM QPSK	1@0	see graph	PASS
48	30	10	637000	3555.0	DFT-s-OFDM QPSK	1@0	see graph	PASS
48	30	10	641666	3624.99	DFT-s-OFDM BPSK	1@0	see graph	---
48	30	10	641666	3624.99	DFT-s-OFDM BPSK	1@0	see graph	PASS
48	30	10	641666	3624.99	DFT-s-OFDM BPSK	1@0	see graph	PASS
48	30	10	641666	3624.99	DFT-s-OFDM QPSK	1@0	see graph	---
48	30	10	641666	3624.99	DFT-s-OFDM QPSK	1@0	see graph	PASS
48	30	10	641666	3624.99	DFT-s-OFDM QPSK	1@0	see graph	PASS
48	30	10	646332	3694.98	DFT-s-OFDM BPSK	1@0	see graph	---
48	30	10	646332	3694.98	DFT-s-OFDM BPSK	1@0	see graph	PASS
48	30	10	646332	3694.98	DFT-s-OFDM BPSK	1@0	see graph	PASS
48	30	10	646332	3694.98	DFT-s-OFDM QPSK	1@0	see graph	---
48	30	10	646332	3694.98	DFT-s-OFDM QPSK	1@0	see graph	PASS
48	30	10	646332	3694.98	DFT-s-OFDM QPSK	1@0	see graph	PASS
48	30	20	637334	3560.01	DFT-s-OFDM BPSK	1@0	see graph	---
48	30	20	637334	3560.01	DFT-s-OFDM BPSK	1@0	see graph	PASS
48	30	20	637334	3560.01	DFT-s-OFDM BPSK	1@0	see graph	PASS
48	30	20	637334	3560.01	DFT-s-OFDM QPSK	1@0	see graph	---
48	30	20	637334	3560.01	DFT-s-OFDM QPSK	1@0	see graph	PASS
48	30	20	637334	3560.01	DFT-s-OFDM QPSK	1@0	see graph	PASS
48	30	20	641666	3624.99	DFT-s-OFDM BPSK	1@0	see graph	---
48	30	20	641666	3624.99	DFT-s-OFDM BPSK	1@0	see graph	PASS
48	30	20	641666	3624.99	DFT-s-OFDM BPSK	1@0	see graph	PASS
48	30	20	641666	3624.99	DFT-s-OFDM QPSK	1@0	see graph	---
48	30	20	641666	3624.99	DFT-s-OFDM QPSK	1@0	see graph	PASS
48	30	20	641666	3624.99	DFT-s-OFDM QPSK	1@0	see graph	PASS
48	30	20	646000	3690.0	DFT-s-OFDM BPSK	1@0	see graph	---
48	30	20	646000	3690.0	DFT-s-OFDM BPSK	1@0	see graph	PASS
48	30	20	646000	3690.0	DFT-s-OFDM BPSK	1@0	see graph	PASS
48	30	20	646000	3690.0	DFT-s-OFDM QPSK	1@0	see graph	---
48	30	20	646000	3690.0	DFT-s-OFDM QPSK	1@0	see graph	PASS
48	30	20	646000	3690.0	DFT-s-OFDM QPSK	1@0	see graph	PASS
48	30	40	638000	3570.0	DFT-s-OFDM BPSK	1@0	see graph	---
48	30	40	638000	3570.0	DFT-s-OFDM BPSK	1@0	see graph	PASS
48	30	40	638000	3570.0	DFT-s-OFDM BPSK	1@0	see graph	PASS



48	30	40	638000	3570.0	DFT-s-OFDM QPSK	1@0	see graph	---
48	30	40	638000	3570.0	DFT-s-OFDM QPSK	1@0	see graph	PASS
48	30	40	638000	3570.0	DFT-s-OFDM QPSK	1@0	see graph	PASS
48	30	40	641666	3624.99	DFT-s-OFDM BPSK	1@0	see graph	---
48	30	40	641666	3624.99	DFT-s-OFDM BPSK	1@0	see graph	PASS
48	30	40	641666	3624.99	DFT-s-OFDM BPSK	1@0	see graph	PASS
48	30	40	641666	3624.99	DFT-s-OFDM QPSK	1@0	see graph	---
48	30	40	641666	3624.99	DFT-s-OFDM QPSK	1@0	see graph	PASS
48	30	40	641666	3624.99	DFT-s-OFDM QPSK	1@0	see graph	PASS
48	30	40	645332	3679.98	DFT-s-OFDM BPSK	1@0	see graph	---
48	30	40	645332	3679.98	DFT-s-OFDM BPSK	1@0	see graph	PASS
48	30	40	645332	3679.98	DFT-s-OFDM BPSK	1@0	see graph	PASS
48	30	40	645332	3679.98	DFT-s-OFDM QPSK	1@0	see graph	---
48	30	40	645332	3679.98	DFT-s-OFDM QPSK	1@0	see graph	PASS
48	30	40	645332	3679.98	DFT-s-OFDM QPSK	1@0	see graph	PASS



N48(10M)\_DFT-s-OFDM\_BPSK\_Edge\_1RB\_Left\_Low\_CH

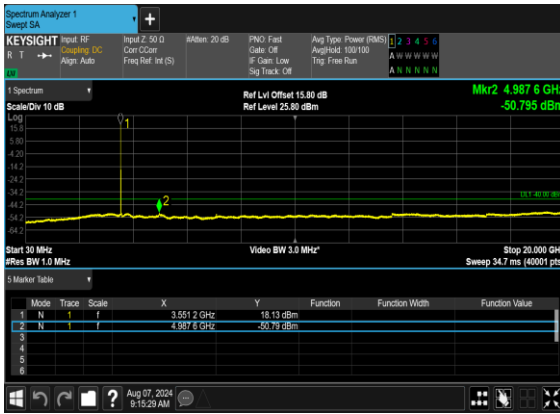

N48(10M)\_DFT-s-OFDM\_BPSK\_Edge\_1RB\_Left\_Low\_CH

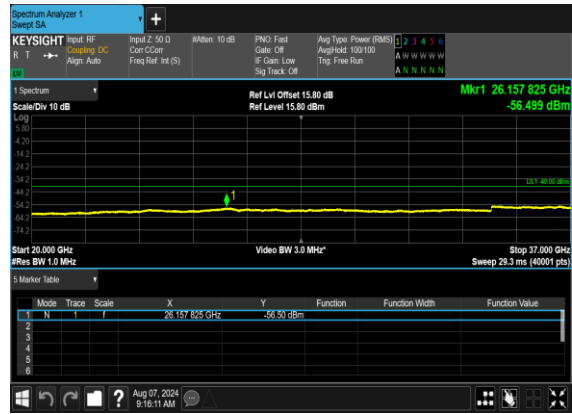

N48(10M)\_DFT-s-OFDM\_QPSK\_Edge\_1RB\_Left\_Low\_CH

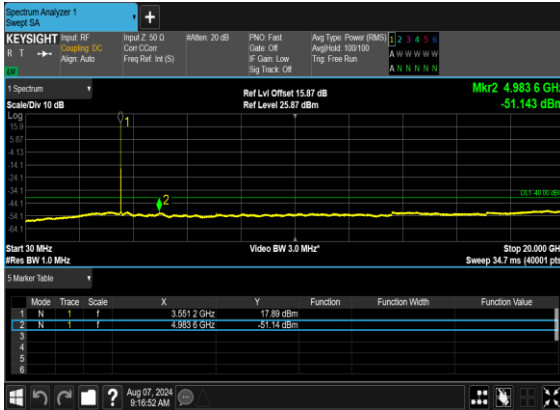

N48(10M)\_DFT-s-OFDM\_QPSK\_Edge\_1RB\_Left\_Low\_CH





N48(10M)\_DFT-s-OFDM\_BPSK\_Edge\_1RB\_Left\_Mid\_CH



N48(10M)\_DFT-s-OFDM\_BPSK\_Edge\_1RB\_Left\_Mid\_CH

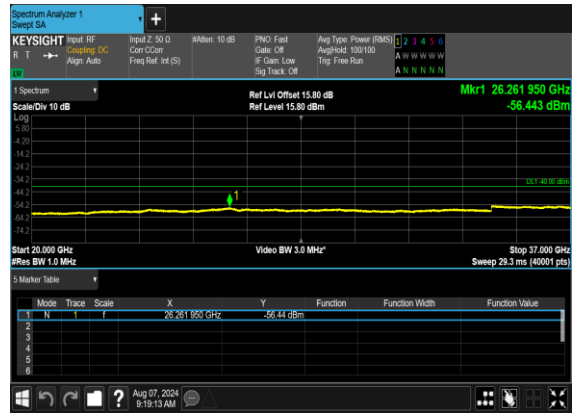

N48(10M)\_DFT-s-OFDM\_QPSK\_Edge\_1RB\_Left\_Mid\_CH

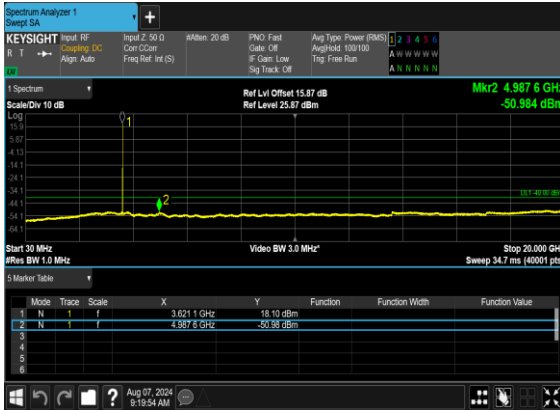

N48(10M)\_DFT-s-OFDM\_QPSK\_Edge\_1RB\_Left\_Mid\_CH

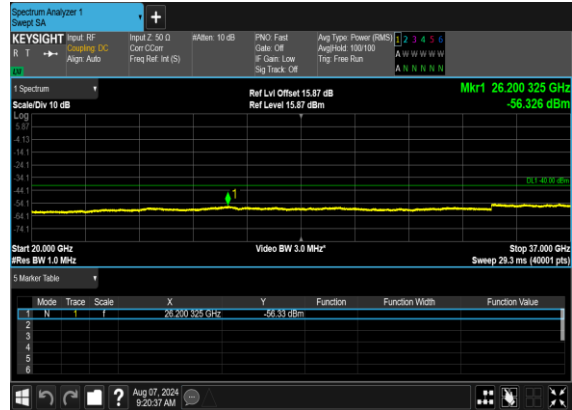





N48(10M)\_DFT-s-OFDM\_BPSK\_Edge\_1RB\_Left\_High\_CH

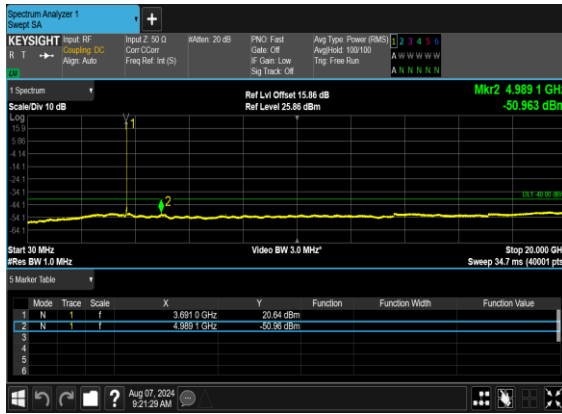

N48(10M)\_DFT-s-OFDM\_BPSK\_Edge\_1RB\_Left\_High\_CH

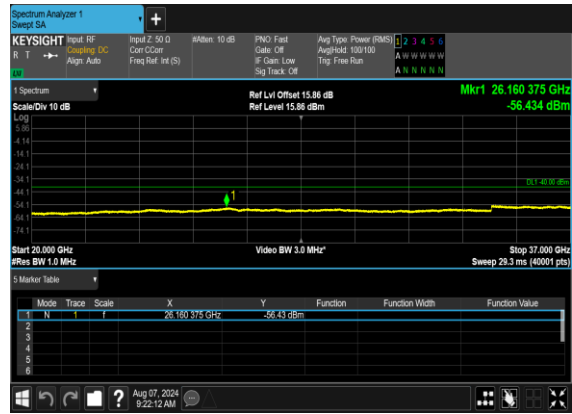

N48(10M)\_DFT-s-OFDM\_QPSK\_Edge\_1RB\_Left\_High\_CH



N48(10M)\_DFT-s-OFDM\_QPSK\_Edge\_1RB\_Left\_High\_CH

