



FCC RF Test Report

APPLICANT : OnePlus Technology (Shenzhen) Co., Ltd.
EQUIPMENT : Mobile Phone
BRAND NAME : ONEPLUS, 
MODEL NAME : CPH2655
FCC ID : 2ABZ2-OP23895
STANDARD : 47 CFR Part 22(H), 27(F), 27(H), 27(N)
CLASSIFICATION : PCS Licensed Transmitter Held to Ear (PCE)
TEST DATE(S) : Aug. 01, 2024 ~ Sep. 03, 2024

We, Sporton International Inc. (ShenZhen), would like to declare that the tested sample has been evaluated in accordance with the procedures given in ANSI C63.26-2015 and shown compliance with the applicable technical standards.

The test results in this report apply exclusively to the tested model / sample. Without written approval of Sporton International Inc. (ShenZhen), the test report shall not be reproduced except in full.

Jason Jia



Approved by: Jason Jia

Sporton International Inc. (ShenZhen)

1/F, 2/F, Bldg 5, Shiling Industrial Zone, Xinwei Village, Xili, Nanshan, Shenzhen, 518055

People's Republic of China



TABLE OF CONTENTS

REVISION HISTORY...3
SUMMARY OF TEST RESULT...4
1 GENERAL DESCRIPTION...5
1.1 Applicant...5
1.2 Manufacturer...5
1.3 Product Feature of Equipment Under Test...5
1.4 Product Specification of Equipment Under Test...5
1.5 Modification of EUT...6
1.6 Maximum ERP Power and Emission Designator...7
1.7 Testing Location...8
1.8 Test Software...9
1.9 Applicable Standards...9
2 TEST CONFIGURATION OF EQUIPMENT UNDER TEST...10
2.1 Test Mode...10
2.2 Connection Diagram of Test System...11
2.3 Support Unit used in test configuration and system...12
2.4 Measurement Results Explanation Example...12
2.5 Frequency List of Low/Middle/High Channels...12
3 CONDUCTED TEST ITEMS...15
3.1 Measuring Instruments...15
3.2 Test Setup...15
3.3 Test Result of Conducted Test...15
3.4 Conducted Output Power and ERP...16
3.5 Peak-to-Average Ratio...17
3.6 Occupied Bandwidth...18
3.7 Conducted Band Edge...19
3.8 Conducted Spurious Emission...21
3.9 Frequency Stability...22
4 RADIATED TEST ITEMS...23
4.1 Measuring Instruments...23
4.2 Test Setup...23
4.3 Test Result of Radiated Test...24
4.4 Radiated Spurious Emission...25
5 LIST OF MEASURING EQUIPMENT...26
6 MEASUREMENT UNCERTAINTY...27
APPENDIX A. TEST RESULTS OF CONDUCTED TEST
APPENDIX B. TEST RESULTS OF RADIATED TEST
APPENDIX C. TEST SETUP PHOTOGRAPHS



REVISION HISTORY

REPORT NO.	VERSION	DESCRIPTION	ISSUED DATE
FG461101C	Rev. 01	Initial issue of report	Sep. 27, 2024



SUMMARY OF TEST RESULT

Report Section	FCC Rule	Description	Limit	Result	Remark
3.4	§2.1046	Conducted Output Power	-	Report Only	-
	§22.913(a)(5)	Effective Radiated Power (Band 5) (Band 26)	ERP < 7 Watt	PASS	-
	§27.50(b)(10) §27.50(c)(10)	Effective Radiated Power (Band 12) (Band 13) (Band 17) (Band 71)	ERP < 3 Watt		-
3.5	N/A	Peak-to-Average Ratio	<13 dB	PASS	-
3.6	§2.1049	Occupied Bandwidth	-	Report Only	-
3.7	§2.1051 §22.917(a) §27.53(c)(2)(4) §27.53(g)	Conducted Band Edge Measurement (Band 5) (Band 12) (Band 13) (Band 17) (Band 26) (Band 71)	< 43+10log ₁₀ (P[Watts])	PASS	-
3.8	§2.1051 §22.917(a) §27.53(c)(2) §27.53(g)	Conducted Spurious Emission (Band 5) (Band 12) (Band 13) (Band 17) (Band 26) (Band 71)	< 43+10log ₁₀ (P[Watts])	PASS	-
3.9	§2.1055 §22.355	Frequency Stability Temperature & Voltage	< 2.5 ppm for Part 22	PASS	-
	§2.1055 §27.54		Within Authorized Band		
4.4	§2.1053 §22.917(a) §27.53(c)(2) §27.53(f) §27.53(g)	Radiated Spurious Emission (Band 5) (Band 12) (Band 13) (Band 17) (Band 26) (Band 71)	< 43+10log ₁₀ (P[Watts])	PASS	Under limit 22.28 dB at 1564.50 MHz

Conformity Assessment Condition:

- The test results (PASS/FAIL) with all measurement uncertainty excluded are presented against the regulation limits or in accordance with the requirements stipulated by the applicant/manufacturer who shall bear all the risks of non-compliance that may potentially occur if measurement uncertainty is taken into account.
- The measurement uncertainty please refer to each test result in the section "Measurement Uncertainty"

Disclaimer:

The product specifications of the EUT presented in the test report that may affect the test assessments are declared by the manufacturer who shall take full responsibility for the authenticity.



1 General Description

1.1 Applicant

OnePlus Technology (Shenzhen) Co., Ltd.

18C02, 18C03, 18C04, and 18C05, Shum Yip Terra Building, Binhe Avenue North, Futian District, Shenzhen, Guangdong, P.R. China.

1.2 Manufacturer

OnePlus Technology (Shenzhen) Co., Ltd.

18C02, 18C03, 18C04, and 18C05, Shum Yip Terra Building, Binhe Avenue North, Futian District, Shenzhen, Guangdong, P.R. China.

1.3 Product Feature of Equipment Under Test

Product Feature	
Equipment	Mobile Phone
Brand Name	ONEPLUS, 
Model Name	CPH2655
FCC ID	2ABZ2-OP23895
IMEI Code	Conducted: 866493070032016 Radiation: 866493070032891/866493070032883
HW Version	11
SW Version	OxygenOS V15.0
EUT Stage	Production Unit

1.4 Product Specification of Equipment Under Test

Standards-related Product Specification	
Tx Frequency	LTE Band 5 : 824 MHz ~ 849 MHz LTE Band 12 : 699 MHz ~ 716 MHz LTE Band 13 : 777 MHz ~ 787 MHz LTE Band 17 : 704 MHz ~ 716 MHz LTE Band 26 : 824 MHz ~ 849 MHz LTE Band 71: 663 MHz ~ 698 MHz
Rx Frequency	LTE Band 5 : 869 MHz ~ 894 MHz LTE Band 12 : 729 MHz ~ 746 MHz LTE Band 13 : 746 MHz ~ 756 MHz LTE Band 17 : 734 MHz ~ 746 MHz LTE Band 26 : 869 MHz ~ 894 MHz LTE Band 71: 617 MHz ~ 652 MHz
Bandwidth	LTE Band 5 : 1.4MHz / 3MHz / 5MHz / 10MHz LTE Band 12 : 1.4MHz / 3MHz / 5MHz / 10MHz LTE Band 13 : 5MHz / 10MHz LTE Band 17 : 5MHz / 10MHz



	LTE Band 26 : 1.4MHz / 3MHz / 5MHz / 10MHz / 15MHz LTE Band 71 : 5MHz / 10MHz / 15MHz / 20MHz
Maximum Output Power to Antenna	<ANT0> LTE Band 5 : 23.75 dBm LTE Band 12 : 23.58 dBm LTE Band 13 : 23.25 dBm LTE Band 17 : 23.50 dBm LTE Band 26 : 23.88 dBm LTE Band 71 : 23.20 dBm <ANT1> LTE Band 5 : 23.70 dBm LTE Band 12 : 23.90 dBm LTE Band 13 : 23.45 dBm LTE Band 17 : 23.80 dBm LTE Band 26 : 23.92 dBm LTE Band 71 : 23.88 dBm
Antenna Gain	<ANT0> LTE Band 5 : -2.0 dBi LTE Band 12 : -1.5 dBi LTE Band 13 : -2.0 dBi LTE Band 17 : -1.5 dBi LTE Band 26 : -2.0 dBi LTE Band 71 : -3.0 dBi <ANT1> LTE Band 5 : -4.4 dBi LTE Band 12 : -4.0 dBi LTE Band 13 : -4.0 dBi LTE Band 17 : -4.0 dBi LTE Band 26 : -4.4 dBi LTE Band 71 : -4.0 dBi
Type of Modulation	QPSK / 16QAM / 64QAM / 256QAM

Note: The maximum ERP is calculated from max output power and max antenna gain, so only the maximum ERP of Antenna 0 for LTE Band5/12/13/17/26/71 are shown in the report.

1.5 Modification of EUT

No modifications are made to the EUT during all test items.



1.6 Maximum ERP Power and Emission Designator

LTE Band 5		QPSK		16QAM/64QAM/256QAM	
BW (MHz)	Frequency Range (MHz)	Maximum ERP(W)	Emission Designator (99%OBW)	Maximum ERP(W)	Emission Designator (99%OBW)
1.4	824.7 ~ 848.3	0.0883	1M09G7D	0.0700	1M10W7D
3	825.5 ~ 847.5	0.0885	2M72G7D	0.0701	2M72W7D
5	826.5 ~ 846.5	0.0877	4M47G7D	0.0698	4M47W7D
10	829.0 ~ 844.0	0.0912	9M05G7D	0.0710	8M99W7D
LTE Band 12		QPSK		16QAM/64QAM/256QAM	
BW (MHz)	Frequency Range (MHz)	Maximum ERP(W)	Emission Designator (99%OBW)	Maximum ERP(W)	Emission Designator (99%OBW)
1.4	699.7 ~ 715.3	0.0951	1M09G7D	0.0783	1M11W7D
3	700.5 ~ 714.5	0.0948	2M74G7D	0.0778	2M75W7D
5	701.5 ~ 713.5	0.0962	4M49G7D	0.0778	4M52W7D
10	704.0 ~ 711.0	0.0984	9M05G7D	0.0791	9M01W7D
LTE Band 13		QPSK		16QAM/64QAM/256QAM	
BW (MHz)	Frequency Range (MHz)	Maximum ERP(W)	Emission Designator (99%OBW)	Maximum ERP(W)	Emission Designator (99%OBW)
5	779.5 ~ 784.5	0.0743	4M49G7D	0.0587	4M50W7D
10	782.0	0.0813	9M01G7D	0.0592	9M01W7D
LTE Band 17		QPSK		16QAM/64QAM/256QAM	
BW (MHz)	Frequency Range (MHz)	Maximum ERP(W)	Emission Designator (99%OBW)	Maximum ERP(W)	Emission Designator (99%OBW)
5	706.5 ~ 713.5	0.0944	4M49G7D	0.0822	4M52W7D
10	709.0 ~ 711.0	0.0966	9M05G7D	0.0834	9M01W7D



LTE Band 26		QPSK		16QAM/64QAM/256QAM	
BW (MHz)	Frequency Range (MHz)	Maximum ERP(W)	Emission Designator (99%OBW)	Maximum ERP(W)	Emission Designator (99%OBW)
1.4	824.7 ~ 848.3	0.0920	1M09G7D	0.0716	1M10W7D
3	825.5 ~ 847.5	0.0899	2M72G7D	0.0719	2M72W7D
5	826.5 ~ 846.5	0.0920	4M47G7D	0.0708	4M47W7D
10	829.0 ~ 844.0	0.0906	9M05G7D	0.0726	8M99W7D
15	831.5 ~ 841.5	0.0940	13M5G7D	0.0731	13M5W7D
CH26790	824.0	0.0940	13M5G7D	0.0738	13M5W7D
LTE Band 71		QPSK		16QAM/64QAM/256QAM	
BW (MHz)	Frequency Range (MHz)	Maximum ERP(W)	Emission Designator (99%OBW)	Maximum ERP(W)	Emission Designator (99%OBW)
5	665.5 ~ 695.5	0.0615	4M49G7D	0.0514	4M49W7D
10	668.0 ~ 693.0	0.0611	8M95G7D	0.0512	9M01W7D
15	670.5 ~ 690.5	0.0624	13M4G7D	0.0504	13M5W7D
20	673.0 ~ 688.0	0.0638	17M9G7D	0.0515	17M9W7D

Note:

1. LTE Band 26 overlaps the entire frequency range of LTE Band 5. Therefore, the test results provided in this report covers Band 5 and the portion of Band 26 subject to Part 22.
2. LTE Band 12 overlaps the entire frequency range of LTE Band 17. Therefore, the test results provided in this report covers Band 12 as well as Band 17.

1.7 Testing Location

Sporton International Inc. (ShenZhen) is accredited to ISO/IEC 17025:2017 by American Association for Laboratory Accreditation with Certificate Number 5145.01.

Test Firm	Sporton International Inc. (ShenZhen)		
Test Site Location	1/F, 2/F, Bldg 5, Shiling Industrial Zone, Xinwei Village, Xili, Nanshan, Shenzhen, 518055 People's Republic of China TEL: +86-755-86379589 FAX: +86-755-86379595		
Test Site No.	Sporton Site No.	FCC Designation No.	FCC Test Firm Registration No.
	TH01-SZ	CN1256	421272



Test Firm	Sporton International Inc. (ShenZhen)		
Test Site Location	101, 1st Floor, Block B, Building 1, No. 2, Tengfeng 4th Road, Fenghuang Community, Fuyong Street, Baoan District, Shenzhen City, Guangdong Province 518103 People's Republic of China TEL: +86-755-86066985		
Test Site No.	Sporton Site No.	FCC Designation No.	FCC Test Firm Registration No.
	03CH04-SZ	CN1256	421272

1.8 Test Software

Item	Site	Manufacture	Name	Version
1.	03CH04-SZ	AUDIX	E3	6.2009-8-24

1.9 Applicable Standards

According to the specifications of the manufacturer, the EUT must comply with the requirements of the following standards:

- 47 CFR Part 22(H), 27(F), 27(H), 27(N)
- ANSI C63.26-2015
- FCC KDB 971168 D01 Power Meas License Digital Systems v03r01
- FCC KDB 412172 D01 Determining ERP and EIRP v01r01

Remark:

1. All test items were verified and recorded according to the standards and without any deviation during the test.
2. This EUT has also been tested and complied with the requirements of FCC Part 15, Subpart B, recorded in a separate test report.



2 Test Configuration of Equipment Under Test

2.1 Test Mode

Antenna port conducted and radiated test items listed below are performed according to KDB 971168 D01 Power Meas License Digital Systems v03r01 with maximum output power.

Radiated measurements are performed by rotating the EUT in three different orthogonal test planes to find the maximum emission. (X Plane)

Test Items	Band	Bandwidth (MHz)						Modulation				RB #			Test Channel		
		1.4	3	5	10	15	20	QPSK	16 QAM	64 QAM	256 QAM	1	Half	Full	L	M	H
Max. Output Power	5	v	v	v	v	-	-	v	v	v	v	v	v	v	v	v	v
	12	v	v	v	v	-	-	v	v	v	v	v	v	v	v	v	v
	13	-	-	v	v	-	-	v	v	v	v	v	v	v	v	v	v
	17	-	-	v	v			v	v	v	v	v	v	v	v	v	v
	26	v	v	v	v	v	-		v	v	v	v	v	v	v	v	v
	71	-	-	v	v	v	v		v	v	v	v	v	v	v	v	v
Peak-to-Average Ratio	12					-	-	v	v	v				v		v	
	13	-	-		v	-	-	v	v	v				v		v	
	26				v		-	v	v	v				v		v	
	71	-	-				v	v	v	v				v		v	
26dB and 99% Bandwidth	12	v	v	v	v	-	-	v	v					v		v	
	13	-	-	v	v	-	-	v	v					v		v	
	26	v	v	v	v	v	-	v	v					v		v	
	71	-	-	v	v	v	v	v	v					v		v	
Conducted Band Edge	12	v	v	v	v	-	-	v	v	v			v		v		v
	13	-	-	v	v	-	-	v	v	v			v		v		v
	26	v	v	v	v	v	-	v	v	v			v		v		v
	71	-	-	v	v	v	v	v	v	v			v		v		v
Conducted Spurious Emission	12	v	v	v	v	-	-	v					v		v	v	v
	13	-	-	v	v	-	-	v					v		v	v	v
	26	v	v	v	v	v	-	v					v		v	v	v
	71	-	-	v	v	v	v	v					v		v	v	v
Frequency Stability	12				v	-	-	v						v		v	
	13	-	-		v	-	-	v						v		v	
	26				v		-	v						v		v	
	71	-	-		v			v						v		v	



Test Items	Band	Bandwidth (MHz)						Modulation			RB #			Test Channel		
		1.4	3	5	10	15	20	QPSK	16QAM	64QAM	1	Half	Full	L	M	H
E.R.P.	5	v	v	v	v	-	-	v	v	v	v	v	v	v	v	v
	12	v	v	v	v	-	-	v	v	v	v	v	v	v	v	v
	13	-	-	v	v	-	-	v	v	v	v	v	v	v	v	v
	17	-	-	v	v			v	v	v	v	v	v	v	v	v
	26	v	v	v	v	v	-	v	v	v	v	v	v	v	v	v
	71	-	-	v	v	v	v	v	v	v	v	v	v	v	v	v
Radiated Spurious Emission	12	Worst Case												v	v	v
	13	Worst Case												v	v	v
	26	Worst Case												v	v	v
	71	Worst Case												v	v	v
Note	1. The mark "v" means that this configuration is chosen for testing 2. The mark "-" means that this bandwidth is not supported. 3. The device is investigated from 30MHz to 10 times of fundamental signal for radiated spurious emission test under different RB size/offset and modulations in exploratory test. Subsequently, only the worst case emissions are reported.															

2.2 Connection Diagram of Test System

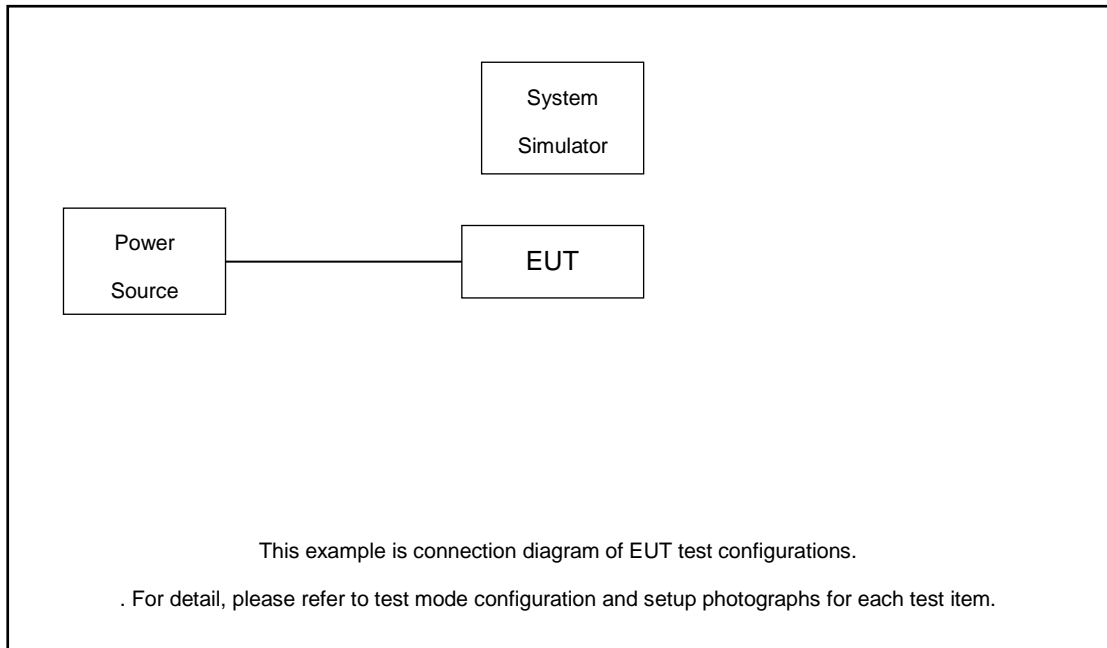



2.3 Support Unit used in test configuration and system

Item	Equipment	Trade Name	Model No.	FCC ID	Data Cable	Power Cord
1.	Power Supply	GWINSTEK	PSS-2002	N/A	N/A	Unshielded, 1.8 m
2.	LTE Base Station	Anritsu	MT8820C	N/A	N/A	Unshielded, 1.8 m

2.4 Measurement Results Explanation Example

For all conducted test items:

The offset level is set in the spectrum analyzer to compensate the RF cable loss and attenuator factor between EUT conducted output port and spectrum analyzer. With the offset compensation, the spectrum analyzer reading level is exactly the EUT RF output level.

The spectrum analyzer offset is derived from RF cable loss and attenuator factor.

Offset = RF cable loss + attenuator factor.

Following shows an offset computation example with cable loss 4.0 dB and 10dB attenuator.

Example :

$$\begin{aligned}
 \text{Offset(dB)} &= \text{RF cable loss(dB)} + \text{attenuator factor(dB)}. \\
 &= 4.0 + 10 = 14.0 \text{ (dB)}
 \end{aligned}$$

2.5 Frequency List of Low/Middle/High Channels

LTE Band 5 Channel and Frequency List				
BW [MHz]	Channel/Frequency(MHz)	Lowest	Middle	Highest
10	Channel	20450	20525	20600
	Frequency	829	836.5	844
5	Channel	20425	20525	20625
	Frequency	826.5	836.5	846.5
3	Channel	20415	20525	20635
	Frequency	825.5	836.5	847.5
1.4	Channel	20407	20525	20643
	Frequency	824.7	836.5	848.3



LTE Band 12 Channel and Frequency List				
BW [MHz]	Channel/Frequency(MHz)	Lowest	Middle	Highest
10	Channel	23060	23095	23130
	Frequency	704	707.5	711
5	Channel	23035	23095	23155
	Frequency	701.5	707.5	713.5
3	Channel	23025	23095	23165
	Frequency	700.5	707.5	714.5
1.4	Channel	23017	23095	23173
	Frequency	699.7	707.5	715.3

LTE Band 13 Channel and Frequency List				
BW [MHz]	Channel/Frequency(MHz)	Lowest	Middle	Highest
10	Channel	-	23230	-
	Frequency	-	782	-
5	Channel	23205	23230	23255
	Frequency	779.5	782	784.5

LTE Band 17 Channel and Frequency List				
BW [MHz]	Channel/Frequency(MHz)	Lowest	Middle	Highest
10	Channel	23780	23790	23800
	Frequency	709	710	711
5	Channel	23755	23790	23825
	Frequency	706.5	710	713.5



LTE Band 26 Channel and Frequency List				
BW [MHz]	Channel/Frequency(MHz)	Lowest	Middle	Highest
15	Channel	26865	26915	26965
	Frequency	831.5	836.5	841.5
10	Channel	26840	26915	26990
	Frequency	829	836.5	844
5	Channel	26815	26915	27015
	Frequency	826.5	836.5	846.5
3	Channel	26805	26915	27025
	Frequency	825.5	836.5	847.5
1.4	Channel	26797	26915	27033
	Frequency	824.7	836.5	848.3

LTE Band 71 Channel and Frequency List				
BW [MHz]	Channel/Frequency(MHz)	Lowest	Middle	Highest
20	Channel	133222	133322	133372
	Frequency	673.0	680.5	688.0
15	Channel	133197	133297	133397
	Frequency	670.5	680.5	690.5
10	Channel	133172	133272	133422
	Frequency	668.0	678.0	693.0
5	Channel	133147	133247	133447
	Frequency	665.5	675.5	695.5

3 Conducted Test Items

3.1 Measuring Instruments

See list of measuring instruments of this test report.

3.2 Test Setup

3.2.1 Conducted Output Power

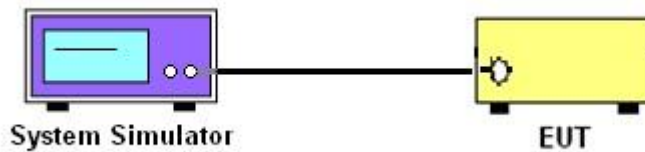

3.2.2 Peak-to-Average Ratio, Occupied Bandwidth ,Conducted Band-Edge and Conducted Spurious Emission

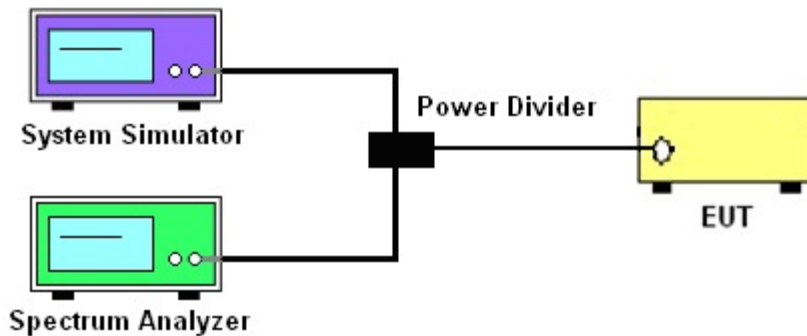

3.2.3 Frequency Stability

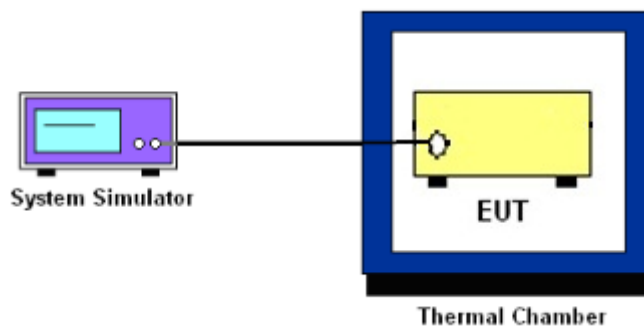

3.3 Test Result of Conducted Test

Please refer to Appendix A.



3.4 Conducted Output Power and ERP

3.4.1 Description of the Conducted Output Power Measurement and ERP Measurement

A system simulator was used to establish communication with the EUT. Its parameters were set to force the EUT transmitting at maximum output power. The measured power in the radio frequency on the transmitter output terminals shall be reported.

The ERP of mobile transmitters must not exceed 7 Watts for LTE Band 5 and Band 26.

The ERP of mobile transmitters must not exceed 3 Watts for LTE Band 12, Band 13 and Band 17 and Band 71.

According to KDB 412172 D01 Power Approach,

$EIRP = P_T + G_T - L_C$, $ERP = EIRP - 2.15$, where

P_T = transmitter output power in dBm

G_T = gain of the transmitting antenna in dBi

L_C = signal attenuation in the connecting cable between the transmitter and antenna in dB

3.4.2 Test Procedures

1. The testing follows ANSI C63.26 Section 5.2
2. The transmitter output port was connected to the system simulator.
3. Set EUT at maximum power through the system simulator.
4. Select lowest, middle, and highest channels for each band and different modulation.
5. Measure and record the power level from the system simulator.



3.5 Peak-to-Average Ratio

3.5.1 Description of the PAR Measurement

Power Complementary Cumulative Distribution Function (CCDF) curves provide a means for characterizing the power peaks of a digitally modulated signal on a statistical basis. A CCDF curve depicts the probability of the peak signal amplitude exceeding the average power level. Most contemporary measurement instrumentation include the capability to produce CCDF curves for an input signal provided that the instrument's resolution bandwidth can be set wide enough to accommodate the entire input signal bandwidth. In measuring transmissions in this band using an average power technique, the peak-to-average ratio (PAR) of the transmission may not exceed 13 dB.

3.5.2 Test Procedures

1. The testing follows ANSI C63.26 Section 5.2.3.4 (CCDF).
2. The EUT was connected to spectrum and system simulator via a power divider.
3. Set the CCDF (Complementary Cumulative Distribution Function) option in spectrum analyzer.
4. The highest RF powers were measured and recorded the maximum PAPR level associated with a probability of 0.1 %.
5. Record the deviation as Peak to Average Ratio.



3.6 Occupied Bandwidth

3.6.1 Description of Occupied Bandwidth Measurement

The occupied bandwidth is the width of a frequency band such that, below the lower and above the upper frequency limits, the mean powers emitted are each equal to a specified percentage 0.5% of the total mean transmitted power.

The 26 dB emission bandwidth is defined as the frequency range between two points, one above and one below the carrier frequency, at which the spectral density of the emission is attenuated 26 dB below the maximum in-band spectral density of the modulated signal. Spectral density (power per unit bandwidth) is to be measured with a detector of resolution bandwidth equal to approximately 1.0% of the emission bandwidth.

3.6.2 Test Procedures

1. The testing follows ANSI C63.26 Section 5.4
2. The EUT was connected to spectrum analyzer and system simulator via a power divider.
3. The spectrum analyzer center frequency is set to the nominal EUT channel center frequency. The span range for the spectrum analyzer shall be between two and five times the anticipated OBW.
4. The nominal resolution bandwidth (RBW) shall be in the range of 1 to 5 % of the anticipated OBW, and the VBW shall be at least 3 times the RBW.
5. Set the detection mode to peak, and the trace mode to max hold.
6. Determine the reference value: Set the EUT to transmit a modulated signal. Allow the trace to stabilize. Set the spectrum analyzer marker to the highest level of the displayed trace.
(this is the reference value)
7. Determine the “-26 dB down amplitude” as equal to (Reference Value – X).
8. Place two markers, one at the lowest and the other at the highest frequency of the envelope of the spectral display such that each marker is at or slightly below the “-X dB down amplitude” determined in step 6. If a marker is below this “-X dB down amplitude” value it shall be placed as close as possible to this value. The OBW is the positive frequency difference between the two markers.
9. Use the 99 % power bandwidth function of the spectrum analyzer and report the measured bandwidth.



3.7 Conducted Band Edge

3.7.1 Description of Conducted Band Edge Measurement

22.917(a)

For operations in the 824 – 849 MHz band, the FCC limit is $43 + 10\log_{10}(P[\text{Watts}])$ dB below the transmitter power $P(\text{Watts})$ in a 100kHz bandwidth. However, in the 1MHz bands immediately outside and adjacent to the licensee's frequency block, a resolution bandwidth of at least one percent of the emission bandwidth of the fundamental emission of the transmitter may be employed.

27.53 (c)

For operations in the 776-788 MHz band, the FCC limit is $43 + 10\log_{10}(P[\text{Watts}])$ dB below the transmitter power $P(\text{Watts})$ in a 100 kHz bandwidth. However, in the 100 kHz bands immediately outside and adjacent to the frequency block, a resolution bandwidth of at least 30 kHz may be employed. In addition, the power of any unwanted emissions in any 6.25 kHz bandwidth for all frequencies between 763-775 MHz and 793-806 MHz shall be attenuated below the transmitter power, P (dBW), by at least $65 + 10 \log_{10} p(\text{watts})$, dB, for mobile and portable equipment.

27.53 (g)

For operations in the 600MHz band and 698 -746 MHz band, the FCC limit is $43 + 10\log_{10}(P[\text{Watts}])$ dB below the transmitter power $P(\text{Watts})$ in a 100 kHz bandwidth. However, in the 100 kilohertz bands immediately outside and adjacent to a licensee's frequency block, a resolution bandwidth of at least 30 kHz may be employed.



3.7.2 Test Procedures

1. The testing follows ANSI C63.26 section 5.7
1. The EUT was connected to spectrum analyzer and system simulator via a power divider.
2. The band edges of low and high channels for the highest RF powers were measured.
3. Set RBW \geq 1% EBW in the 1MHz band immediately outside and adjacent to the band edge.
4. Beyond the 1 MHz band from the band edge, RBW=1MHz was used or a narrower RBW was used and the measured power was integrated over the full required measurement bandwidth of 1 MHz.
5. Set spectrum analyzer with RMS detector.
6. The RF fundamental frequency should be excluded against the limit line in the operating frequency band.
7. Checked that all the results comply with the emission limit line.

Example:

The limit line is derived from $43 + 10\log(P)$ dB below the transmitter power P(Watts)

$$= P(W) - [43 + 10\log(P)] \text{ (dB)}$$

$$= [30 + 10\log(P)] \text{ (dBm)} - [43 + 10\log(P)] \text{ (dB)} = -13\text{dBm}.$$

8. When using the integration method, the starting frequency of the integration shall be centered at one-half of the RBW away from the band edge.



3.8 Conducted Spurious Emission

3.8.1 Description of Conducted Spurious Emission Measurement

The power of any emission outside of the authorized operating frequency ranges must be lower than the transmitter power (P) by a factor of at least $43 + 10 \log (P)$ dB.

It is measured by means of a calibrated spectrum analyzer and scanned from 30 MHz up to a frequency including its 10th harmonic.

3.8.2 Test Procedures

1. The testing follows ANSI C63.26 section 5.7
2. The EUT was connected to spectrum analyzer and system simulator via a power divider.
3. The RF output of EUT was connected to the spectrum analyzer by RF cable and attenuator. The path loss was compensated to the results for each measurement.
4. The middle channel for the highest RF power within the transmitting frequency was measured.
5. The conducted spurious emission for the whole frequency range was taken.
6. Make the measurement with the spectrum analyzer's RBW = 1MHz, VBW = 3MHz.
7. Set spectrum analyzer with RMS detector.
8. Taking the record of maximum spurious emission.
9. The RF fundamental frequency should be excluded against the limit line in the operating frequency band.
10. The limit line is derived from $43 + 10\log(P)$ dB below the transmitter power P(Watts)
= P(W)- [43 + 10log(P)] (dB)
= [30 + 10log(P)] (dBm) - [43 + 10log(P)] (dB)
= -13dBm.



3.9 Frequency Stability

3.9.1 Description of Frequency Stability Measurement

The frequency stability shall be measured by variation of ambient temperature and variation of primary supply voltage to ensure that the fundamental emission stays within the authorized frequency block. The frequency stability of the transmitter shall be maintained within $\pm 0.00025\%$ ($\pm 2.5\text{ppm}$) of the center frequency.

3.9.2 Test Procedures for Temperature Variation

1. The testing follows ANSI C63.26 section 5.6.4
2. The EUT was set up in the thermal chamber and connected with the system simulator.
3. With power OFF, the temperature was decreased to -30°C and the EUT was stabilized before testing. Power was applied and the maximum change in frequency was recorded within one minute.
4. With power OFF, the temperature was raised in 10°C step up to 50°C . The EUT was stabilized at each step for at least half an hour. Power was applied and the maximum frequency change was recorded within one minute.

3.9.3 Test Procedures for Voltage Variation

1. The testing follows ANSI C63.26 section 5.6.5
2. The EUT was placed in a temperature chamber at $20\pm 5^{\circ}\text{C}$ and connected with the system simulator.
3. The power supply voltage to the EUT was varied from 85% to 115% of the nominal value for other than hand carried battery equipment.
4. For hand carried, battery powered equipment, reduce the primary ac or dc supply voltage to the battery operating end point, which shall be specified by the manufacturer.
5. The variation in frequency was measured for the worst case.

4 Radiated Test Items

4.1 Measuring Instruments

See list of measuring instruments of this test report.

4.2 Test Setup

4.2.1 For radiated test below 30MHz

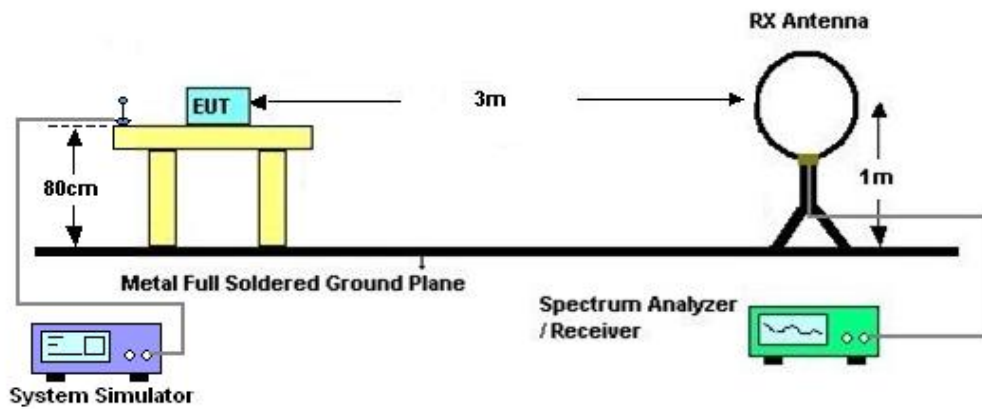

4.2.2 For radiated test from 30MHz to 1GHz

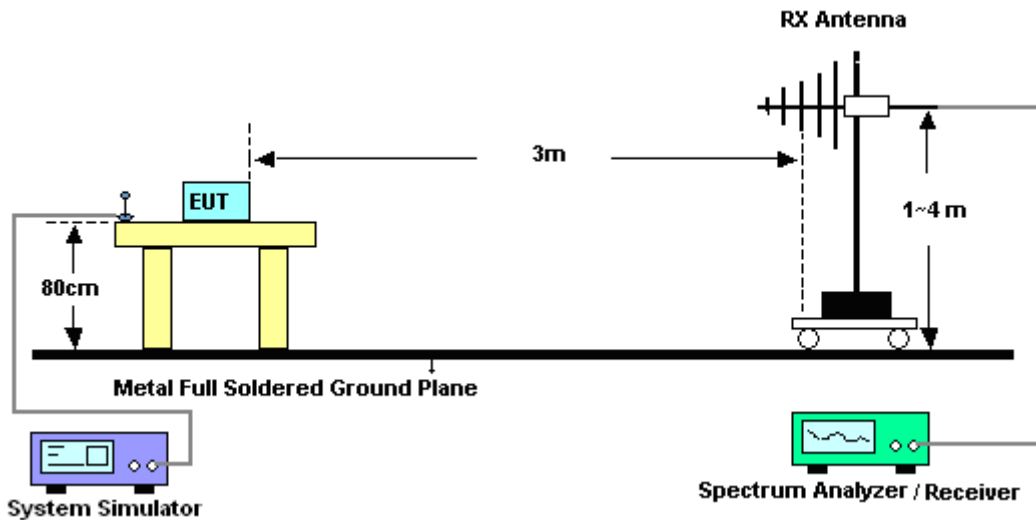

4.2.3 For radiated test above 1GHz

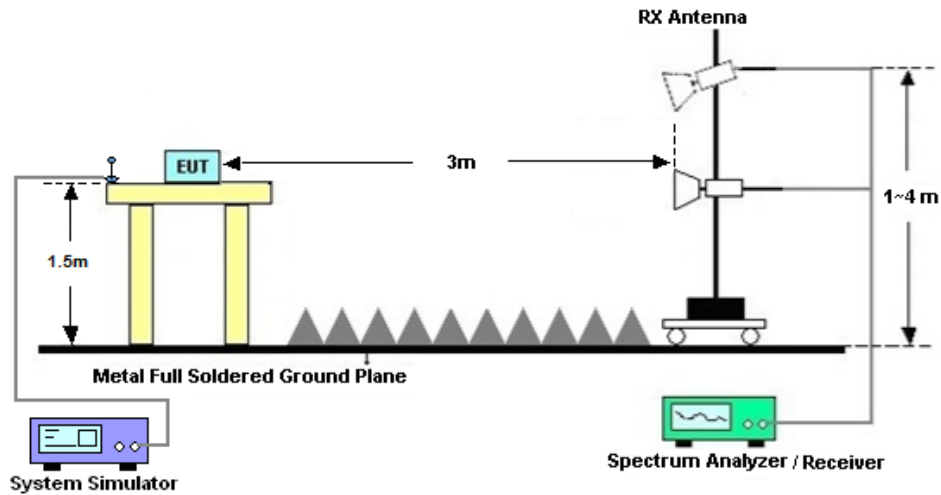

4.3 Test Result of Radiated Test

The low frequency, which started from 9 kHz to 30MHz, was pre-scanned and the result which was 20dB lower than the limit line was not reported.

Please refer to Appendix B.



4.4 Radiated Spurious Emission

4.4.1 Description of Radiated Spurious Emission

The radiated spurious emission was measured by substitution method according to ANSI C63.26. The power of any emission outside of the authorized operating frequency ranges must be attenuated below the transmitter power (P) by a factor of at least $43 + 10 \log (P)$ dB.

For LTE Band 13

For operations in the 746-758 MHz, 775-788 MHz, and 805-806 MHz bands, emissions in the band 1559-1610 MHz shall be limited to -70 dBW/MHz equivalent isotropically radiated power (EIRP) for wideband signals, and -80 dBW EIRP for discrete emissions of less than 700 Hz bandwidth.

The spectrum is scanned from 30 MHz up to a frequency including its 10th harmonic.

4.4.2 Test Procedures

1. The testing follows ANSI C63.26 Section 5.5
2. The EUT was placed on a turntable with 0.8 meter height for frequency below 1GHz and 1.5 meter height for frequency above 1GHz respectively above ground.
3. The EUT was set 3 meters from the receiving antenna mounted on the antenna tower.
4. The table was rotated 360 degrees to determine the position of the highest spurious emission.
5. The height of the receiving antenna is varied between 1m to 4m to search the maximum spurious emission for both horizontal and vertical polarizations.
6. During the measurement, the system simulator parameters were set to force the EUT transmitting at maximum output power.
7. Make the measurement with the spectrum analyzer's RBW = 1MHz, VBW = 3MHz, taking the record of maximum spurious emission.
8. A horn antenna was substituted in place of the EUT and was driven by a signal generator.
9. Tune the output power of signal generator to the same emission level with EUT maximum spurious emission.
10. $EIRP (dBm) = S.G. Power - Tx Cable Loss + Tx Antenna Gain$
11. $ERP (dBm) = EIRP - 2.15$
12. The RF fundamental frequency should be excluded against the limit line in the operating frequency band.

The limit line is derived from $43 + 10\log(P)$ dB below the transmitter power P(Watts)
= $P(W) - [43 + 10\log(P)] (dB)$
= $[30 + 10\log(P)] (dBm) - [43 + 10\log(P)] (dB)$
= $-13dBm$.



5 List of Measuring Equipment

Instrument	Manufacturer	Model No.	Serial No.	Characteristics	Calibration Date	Test Date	Due Date	Remark
Spectrum Analyzer	R&S	FSV40	101078	10Hz~40GHz	Apr. 09, 2024	Aug. 06, 2024~ Sep. 03, 2024	Apr. 08, 2025	Conducted (TH01-SZ)
DC Power Supply	TTI	PL330P	290070	Max 32V , 3A	Oct. 16, 2023	Aug. 06, 2024~ Sep. 03, 2024	Oct. 15, 2024	Conducted (TH01-SZ)
Power Divider	TOJOIN	PS-2SM-04 265	60.06.020.007 7	0.4GHz~26.5GHz	Dec. 25, 2023	Aug. 06, 2024~ Sep. 03, 2024	Dec. 24, 2024	Conducted (TH01-SZ)
Thermal Chamber	Ten Billion Hongzhangroup	LP-150U	H2014081803	-40~+150°C	Jul. 03, 2024	Aug. 06, 2024~ Sep. 03, 2024	Jul. 02, 2025	Conducted (TH01-SZ)
EMI Test Receiver	R&S	ESR7	101404	9kHz~7GHz	Oct. 18, 2023	Aug. 01, 2024~ Aug. 11, 2024	Oct. 17, 2024	Radiation (03CH04-SZ)
EXA Spectrum Analyzer	KEYSIGHT	N9010A	MY55150213	10Hz~44GHz	Jul. 03, 2024	Aug. 01, 2024~ Aug. 11, 2024	Jul. 02, 2025	Radiation (03CH04-SZ)
Loop Antenna	R&S	HFH2-Z2E	101141	9kHz~30MHz	Dec. 29, 2023	Aug. 01, 2024~ Aug. 11, 2024	Dec. 28, 2024	Radiation (03CH04-SZ)
Bilog Antenna	TeseQ	CBL6111D	41909	30MHz~1GHz	May 09 2024	Aug. 01, 2024~ Aug. 11, 2024	May 08, 2025	Radiation (03CH04-SZ)
Double Ridge Horn Antenna	SCHWARZBECK	BBHA9120D	9120D-1474	1GHz~18GHz	Jul. 06, 2024	Aug. 01, 2024~ Aug. 11, 2024	Jul. 05, 2025	Radiation (03CH04-SZ)
Horn Antenna	SCHWARZBECK	BBHA9170	9170#679	15GHz~40GHz	Jul. 04, 2024	Aug. 01, 2024~ Aug. 11, 2024	Jul. 03, 2025	Radiation (03CH04-SZ)
Amplifier	Burgeon	BPA-530	102211	0.01Hz ~3000MHz	Oct. 18, 2023	Aug. 01, 2024~ Aug. 11, 2024	Oct. 17, 2024	Radiation (03CH04-SZ)
HF Amplifier	MITEQ	AMF-7D-00 101800-30-1 0P-R	1943528	1GHz~18GHz	Oct. 18, 2023	Aug. 01, 2024~ Aug. 11, 2024	Oct. 17, 2024	Radiation (03CH04-SZ)
HF Amplifier	MITEQ	TTA1840-35 -HG	1871923	18GHz~40GHz	Jul. 03, 2024	Aug. 01, 2024~ Aug. 11, 2024	Jul. 02, 2025	Radiation (03CH04-SZ)
Amplifier	Agilent Technologies	83017A	MY57280136	500MHz~26.5GHz	Jul. 03, 2024	Aug. 01, 2024~ Aug. 11, 2024	Jul. 02, 2025	Radiation (03CH04-SZ)
AC Power Source	APC	AFV-S-600B	F119050019	N/A	Oct. 18, 2023	Aug. 01, 2024~ Aug. 11, 2024	Oct. 17, 2024	Radiation (03CH04-SZ)
Turn Table	EM	EM1000	N/A	0~360 degree	NCR	Aug. 01, 2024~ Aug. 11, 2024	NCR	Radiation (03CH04-SZ)
Antenna Mast	EM	EM1000	N/A	1 m~4 m	NCR	Aug. 01, 2024~ Aug. 11, 2024	NCR	Radiation (03CH04-SZ)

NCR: No Calibration Required



6 Measurement Uncertainty

The measurement uncertainties shown below were calculated in accordance with the requirements of ANSI 63.26-2015. All the measurement uncertainty value were shown with a coverage K=2 to indicate 95% level of confidence. The measurement data show herein meets or exceeds the CISPR measurement uncertainty values specified in CISPR 16-4-2 and can be compared directly to specified limit to determine compliance.

Uncertainty of Conducted Measurement

Test Item	Uncertainty
Conducted Spurious Emission & Bandedge	±1.34 dB
Occupied Channel Bandwidth	±0.012 MHz
Conducted Power	±1.34 dB
Peak to Average Ratio	±1.34 dB
Frequency Stability	±1.3 Hz

Uncertainty of Radiated Emission Measurement (30 MHz ~ 1000 MHz)

Measuring Uncertainty for a Level of Confidence of 95% (U = 2Uc(y))	2.8 dB
---	--------

Uncertainty of Radiated Emission Measurement (1 GHz ~ 18 GHz)

Measuring Uncertainty for a Level of Confidence of 95% (U = 2Uc(y))	3.1 dB
---	--------

Uncertainty of Radiated Emission Measurement (18 GHz ~ 40 GHz)

Measuring Uncertainty for a Level of Confidence of 95% (U = 2Uc(y))	3.9 dB
---	--------

----- THE END -----



Appendix A. Test Results of Conducted Test

Test Engineer :	Lorenzo Liu	Temperature :	24~26°C
		Relative Humidity :	50~53%

Conducted Output Power(Average power) and ERP

LTE Band 5_ANT0:

BW [MHz]	Modulation	RB Size	RB Offset	Power Low Ch. / Freq.	Power Middle Ch. / Freq.	Power High Ch. / Freq.	ERP(W)		
Channel				20450	20525	20600	ERP(W)		
Frequency (MHz)				829	836.5	844	L	M	H
10	QPSK	1	0	23.65	23.69	23.59	0.0891	0.0899	0.0879
10	QPSK	1	25	23.71	23.75	23.67	0.0904	0.0912	0.0895
10	QPSK	1	49	23.43	23.46	23.37	0.0847	0.0853	0.0836
10	QPSK	25	0	22.67	22.65	22.58	0.0711	0.0708	0.0697
10	QPSK	25	12	22.68	22.70	22.65	0.0713	0.0716	0.0708
10	QPSK	25	25	22.63	22.66	22.43	0.0705	0.0710	0.0673
10	QPSK	50	0	22.64	22.65	22.48	0.0706	0.0708	0.0681
10	16QAM	1	0	22.60	22.58	22.66	0.0700	0.0697	0.0710
10	64QAM	1	0	21.75	21.72	21.66	0.0575	0.0571	0.0564
10	256QAM	1	0	18.50	18.62	18.54	0.0272	0.0280	0.0275
Channel				20425	20525	20625	ERP(W)		
Frequency (MHz)				826.5	836.5	846.5	L	M	H
5	QPSK	1	0	23.53	23.58	23.54	0.0867	0.0877	0.0869
5	16QAM	1	0	22.53	22.53	22.59	0.0689	0.0689	0.0698
Channel				20415	20525	20635	ERP(W)		
Frequency (MHz)				825.5	836.5	847.5	L	M	H
3	QPSK	1	0	23.56	23.62	23.58	0.0873	0.0885	0.0877
3	16QAM	1	0	22.56	22.44	22.61	0.0693	0.0675	0.0701
Channel				20407	20525	20643	ERP(W)		
Frequency (MHz)				824.7	836.5	848.3	L	M	H
1.4	QPSK	1	0	23.56	23.61	23.57	0.0873	0.0883	0.0875
1.4	16QAM	1	0	22.56	22.52	22.60	0.0693	0.0687	0.0700



LTE Band 12_ANT0:

BW [MHz]	Modulation	RB Size	RB Offset	Power Low Ch. / Freq.	Power Middle Ch. / Freq.	Power High Ch. / Freq.	ERP(W)		
Channel				23060	23095	23130	ERP(W)		
Frequency (MHz)				704	707.5	711	L	M	H
10	QPSK	1	0	23.50	23.50	23.53	0.0966	0.0966	0.0973
10	QPSK	1	25	23.58	23.55	23.54	0.0984	0.0977	0.0975
10	QPSK	1	49	23.45	23.32	23.41	0.0955	0.0927	0.0946
10	QPSK	25	0	22.51	22.59	22.60	0.0769	0.0783	0.0785
10	QPSK	25	12	22.69	22.67	22.66	0.0802	0.0798	0.0796
10	QPSK	25	25	22.59	22.66	22.65	0.0783	0.0796	0.0794
10	QPSK	50	0	22.61	22.57	22.50	0.0787	0.0780	0.0767
10	16QAM	1	0	22.61	22.63	22.54	0.0787	0.0791	0.0774
10	64QAM	1	0	21.78	21.68	21.74	0.0650	0.0635	0.0644
10	256QAM	1	0	18.55	18.60	18.52	0.0309	0.0313	0.0307
Channel				23035	23095	23155	ERP(W)		
Frequency (MHz)				701.5	707.5	713.5	L	M	H
5	QPSK	1	0	23.39	23.39	23.48	0.0942	0.0942	0.0962
5	16QAM	1	0	22.49	22.56	22.47	0.0766	0.0778	0.0762
Channel				23025	23095	23165	ERP(W)		
Frequency (MHz)				700.5	707.5	714.5	L	M	H
3	QPSK	1	0	23.42	23.40	23.41	0.0948	0.0944	0.0946
3	16QAM	1	0	22.56	22.55	22.53	0.0778	0.0776	0.0773
Channel				23017	23095	23173	ERP(W)		
Frequency (MHz)				699.7	707.5	715.3	L	M	H
1.4	QPSK	1	0	23.37	23.43	23.40	0.0938	0.0951	0.0944
1.4	16QAM	1	0	22.57	22.59	22.47	0.0780	0.0783	0.0762



LTE Band 13_ANT0:

BW [MHz]	Modulation	RB Size	RB Offset	Power Low Ch. / Freq.	Power Middle Ch. / Freq.	Power High Ch. / Freq.	ERP(W)		
Channel				23230					
Frequency (MHz)				782				M	
10	QPSK	1	0		22.92			0.0753	
10	QPSK	1	25		23.25			0.0813	
10	QPSK	1	49		23.11			0.0787	
10	QPSK	25	0		22.10			0.0624	
10	QPSK	25	12		22.30			0.0653	
10	QPSK	25	25		22.19			0.0637	
10	QPSK	50	0		22.14			0.0630	
10	16QAM	1	0		21.87			0.0592	
10	64QAM	1	0		21.20			0.0507	
10	256QAM	1	0		18.00			0.0243	
Channel				23205	23230	23255	ERP(W)		
Frequency (MHz)				779.5	782	784.5	L	M	H
5	QPSK	1	0	22.86	22.79	22.78	0.0743	0.0731	0.0729
5	16QAM	1	0	21.74	21.79	21.84	0.0574	0.0581	0.0587

LTE Band 17_ANT0:

BW [MHz]	Modulation	RB Size	RB Offset	Power Low Ch. / Freq.	Power Middle Ch. / Freq.	Power High Ch. / Freq.	ERP(W)		
Channel				23780	23790	23800			
Frequency (MHz)				709	710	711	L	M	H
10	QPSK	1	0	23.41	23.48	23.40	0.0946	0.0962	0.0944
10	QPSK	1	25	23.42	23.50	23.44	0.0948	0.0966	0.0953
10	QPSK	1	49	23.38	23.45	23.39	0.0940	0.0955	0.0942
10	QPSK	25	0	22.39	22.35	22.30	0.0748	0.0741	0.0733
10	QPSK	25	12	22.40	22.45	22.38	0.0750	0.0759	0.0746
10	QPSK	25	25	22.29	22.34	22.31	0.0731	0.0740	0.0735
10	QPSK	50	0	22.37	22.40	22.39	0.0745	0.0750	0.0748
10	16QAM	1	0	22.86	22.80	22.83	0.0834	0.0822	0.0828
10	64QAM	1	0	21.85	21.60	21.84	0.0661	0.0624	0.0659
10	256QAM	1	0	18.54	18.55	18.50	0.0308	0.0309	0.0305
Channel				23755	23790	23825	ERP(W)		
Frequency (MHz)				706.5	710	713.5	L	M	H
5	QPSK	1	0	23.28	23.40	23.33	0.0918	0.0944	0.0929
5	16QAM	1	0	22.80	22.67	22.70	0.0822	0.0798	0.0804



LTE Band 26_ANT0:

BW [MHz]	Modulation	RB Size	RB Offset	Power Low Ch. / Freq.	Power Low Ch. / Freq.	Power Middle Ch. / Freq.	Power High Ch. / Freq.	ERP(W)			
Channel				26790	26865	26915	26965				
Frequency (MHz)				824	831.5	836.5	841.5	Straddle Ch	L	M	H
15	QPSK	1	0	23.82	23.84	23.80	23.61	0.0927	0.0931	0.0923	0.0883
15	QPSK	1	37	23.84	23.88	23.82	23.75	0.0931	0.0940	0.0927	0.0912
15	QPSK	1	74	23.76	23.80	23.56	23.60	0.0914	0.0923	0.0873	0.0881
15	QPSK	36	0	22.63	22.71	22.69	22.60	0.0705	0.0718	0.0714	0.0700
15	QPSK	36	20	22.79	22.89	22.84	22.75	0.0731	0.0748	0.0740	0.0724
15	QPSK	36	39	22.71	22.78	22.74	22.70	0.0718	0.0729	0.0723	0.0716
15	QPSK	75	0	22.77	22.83	22.74	22.68	0.0728	0.0738	0.0723	0.0713
15	16QAM	1	0	22.76	22.79	22.70	22.64	0.0726	0.0731	0.0716	0.0706
15	64QAM	1	0	21.89	21.90	21.96	21.83	0.0594	0.0596	0.0604	0.0586
15	256QAM	1	0	18.55	18.58	18.49	18.50	0.0275	0.0277	0.0272	0.0272
Channel				26790	26840	26915	26990	ERP(W)			
Frequency (MHz)				824	829	836.5	844	Straddle Ch	L	M	H
10	QPSK	1	0	23.69	23.71	23.72	23.51	0.0899	0.0904	0.0906	0.0863
10	16QAM	1	0	22.73	22.76	22.62	22.50	0.0721	0.0726	0.0703	0.0684
Channel				26790	26815	26915	27015	ERP(W)			
Frequency (MHz)				824	826.5	836.5	846.5	Straddle Ch	L	M	H
5	QPSK	1	0	23.76	23.79	23.77	23.59	0.0914	0.0920	0.0916	0.0879
5	16QAM	1	0	22.61	22.65	22.58	22.57	0.0701	0.0708	0.0697	0.0695
Channel				26790	26815	26915	27025	ERP(W)			
Frequency (MHz)				824	825.5	836.5	847.5	Straddle Ch	L	M	H
3	QPSK	1	0	23.68	23.69	23.67	23.46	0.0897	0.0899	0.0895	0.0853
3	16QAM	1	0	22.71	22.72	22.67	22.62	0.0718	0.0719	0.0711	0.0703
Channel				26790	26797	26915	27033	ERP(W)			
Frequency (MHz)				824	824.7	836.5	848.3	Straddle Ch	L	M	H
1.4	QPSK	1	0	23.75	23.79	23.78	23.54	0.0912	0.0920	0.0918	0.0869
1.4	16QAM	1	0	22.65	22.70	22.64	22.56	0.0708	0.0716	0.0706	0.0693



LTE Band 71_ANT0:

BW [MHz]	Modulation	RB Size	RB Offset	Power Low Ch. / Freq.	Power Middle Ch. / Freq.	Power High Ch. / Freq.	ERP(W)		
Channel				133222	133322	133372	ERP(W)		
Frequency (MHz)				673	683	688	L	M	H
20	QPSK	1	0	23.01	23.12	23.02	0.0611	0.0627	0.0612
20	QPSK	1	49	23.11	23.20	23.16	0.0625	0.0638	0.0632
20	QPSK	1	99	22.95	23.08	22.99	0.0603	0.0621	0.0608
20	QPSK	50	0	22.00	22.12	22.11	0.0484	0.0498	0.0497
20	QPSK	50	24	22.13	22.16	22.14	0.0499	0.0502	0.0500
20	QPSK	50	50	22.04	22.10	22.07	0.0489	0.0495	0.0492
20	QPSK	100	0	22.05	22.15	22.02	0.0490	0.0501	0.0486
20	16QAM	1	0	22.22	22.27	22.26	0.0509	0.0515	0.0514
20	64QAM	1	0	21.06	21.16	21.06	0.0390	0.0399	0.0390
20	256QAM	1	0	18.06	18.10	18.03	0.0195	0.0197	0.0194
Channel				133197	133297	133397	ERP(W)		
Frequency (MHz)				670.5	680.5	690.5	L	M	H
15	QPSK	1	0	22.98	23.10	22.97	0.0607	0.0624	0.0605
15	16QAM	1	0	22.16	22.16	22.17	0.0502	0.0502	0.0504
Channel				133172	133272	133422	ERP(W)		
Frequency (MHz)				668	678	693	L	M	H
10	QPSK	1	0	22.89	23.01	22.98	0.0594	0.0611	0.0607
10	16QAM	1	0	22.17	22.17	22.24	0.0504	0.0504	0.0512
Channel				133147	133247	133447	ERP(W)		
Frequency (MHz)				665.5	675.5	695.5	L	M	H
5	QPSK	1	0	22.94	23.04	22.95	0.0601	0.0615	0.0603
5	16QAM	1	0	22.15	22.26	22.23	0.0501	0.0514	0.0511



LTE Band 12

Peak-to-Average Ratio

Mode	LTE Band 12 / 10MHz			
Mod.	QPSK	16QAM	64QAM	Limit: 13dB
RB Size	Full RB	Full RB	Full RB	Result
Middle CH	4.26	5.45	6.23	PASS

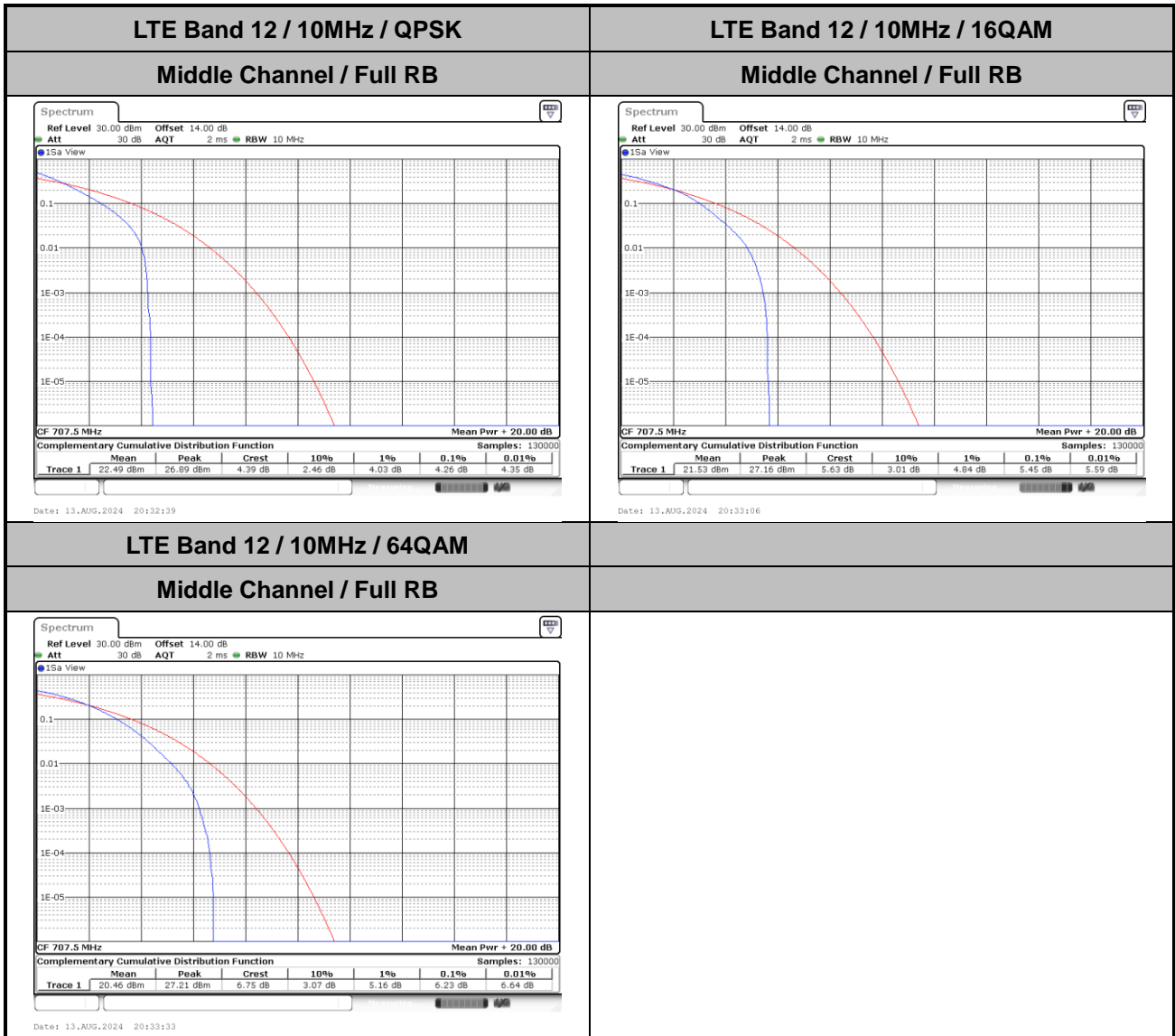



26dB Bandwidth

Mode	LTE Band 12 : 26dB BW(MHz)											
	1.4MHz		3MHz		5MHz		10MHz		15MHz		20MHz	
Mod.	QPSK	16QAM	QPSK	16QAM	QPSK	16QAM	QPSK	16QAM	QPSK	16QAM	QPSK	16QAM
Middle CH	1.36	1.27	3.05	3.05	5.07	5.07	9.93	10.15	-	-	-	-



LTE Band 12

Middle Channel / 1.4MHz / QPSK

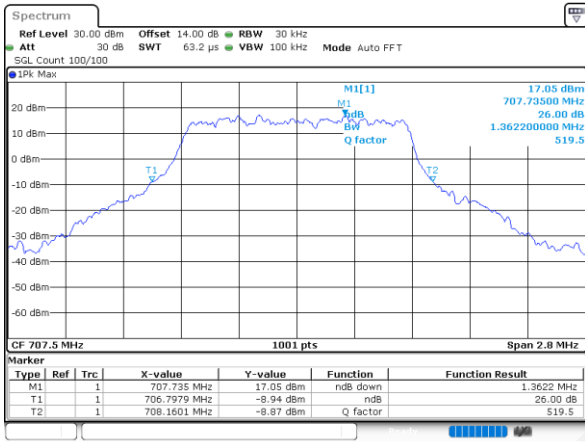

Date: 6.AUG.2024 00:24:49

Middle Channel / 1.4MHz / 16QAM

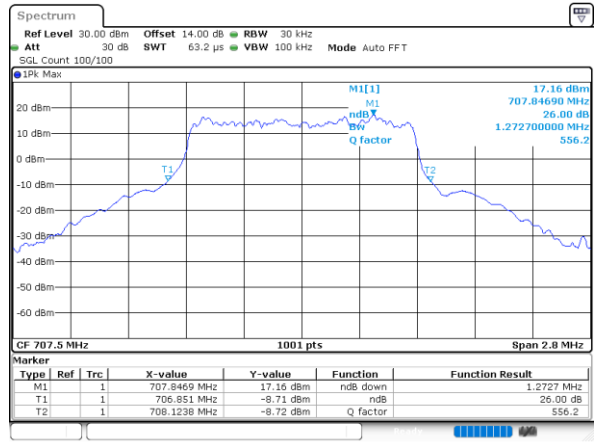

Date: 6.AUG.2024 00:25:29

Middle Channel / 3MHz / QPSK

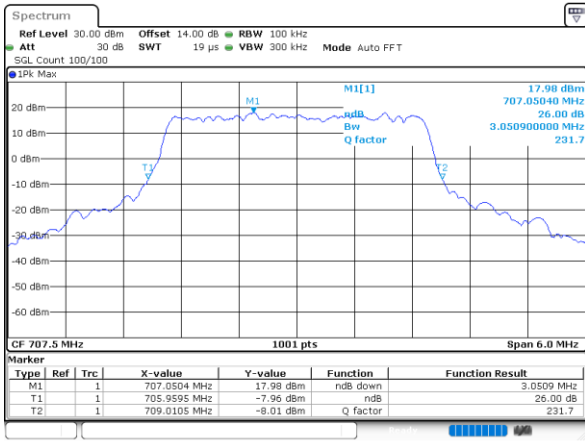

Date: 6.AUG.2024 00:43:16

Middle Channel / 3MHz / 16QAM

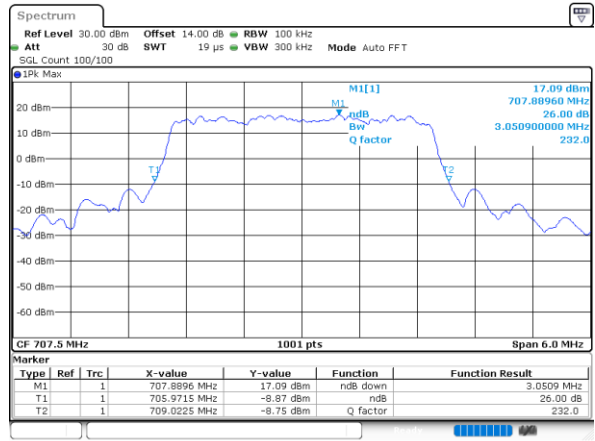

Date: 6.AUG.2024 00:43:56

Middle Channel / 5MHz / QPSK

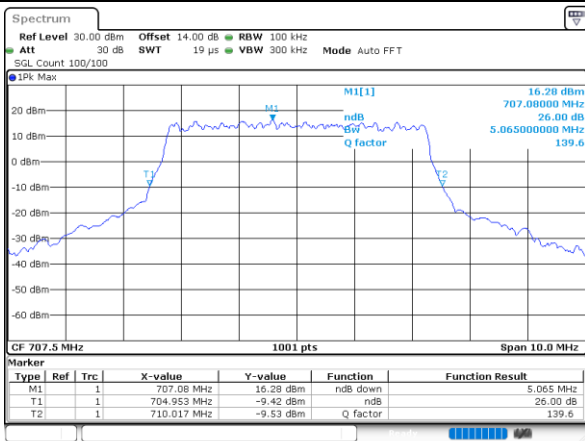

Date: 6.AUG.2024 01:01:18

Middle Channel / 5MHz / 16QAM

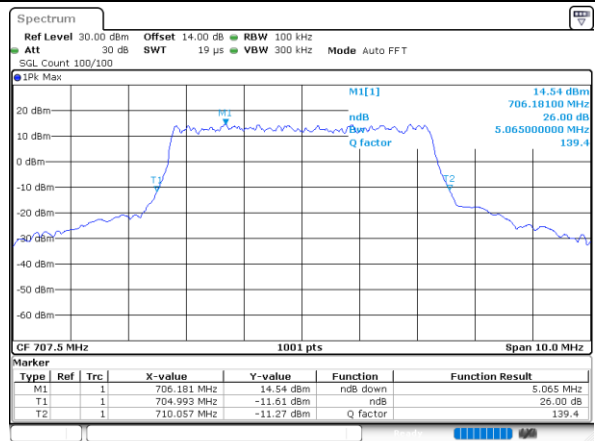

Date: 6.AUG.2024 01:01:58



LTE Band 12

Middle Channel / 10MHz / QPSK

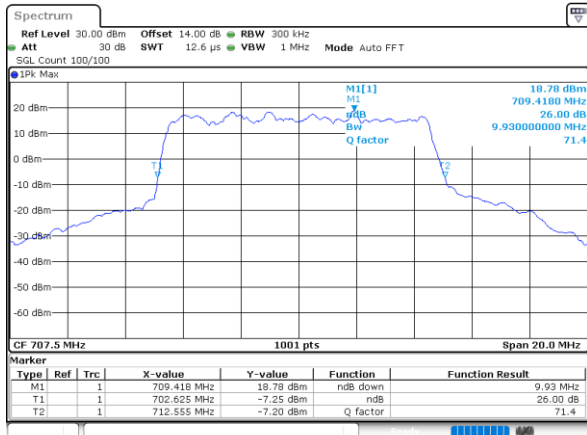

Date: 6.AUG.2024 01:18:14

Middle Channel / 10MHz / 16QAM

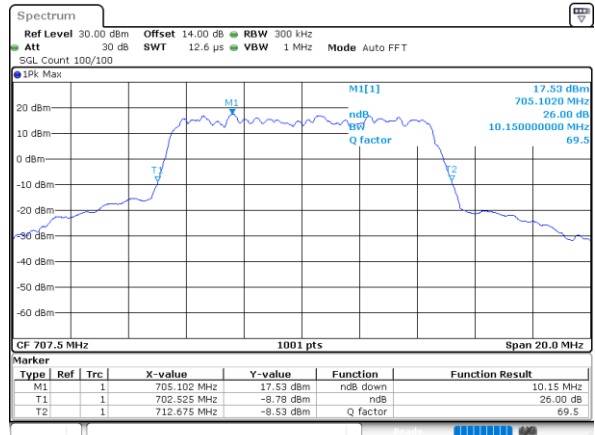

Date: 6.AUG.2024 01:18:55



Occupied Bandwidth

Mode	LTE Band 12 : 99%OBW(MHz)											
	1.4MHz		3MHz		5MHz		10MHz		15MHz		20MHz	
Mod.	QPSK	16QAM	QPSK	16QAM	QPSK	16QAM	QPSK	16QAM	QPSK	16QAM	QPSK	16QAM
Middle CH	1.09	1.11	2.74	2.75	4.49	4.52	9.05	9.01	-	-	-	-



LTE Band 12

Middle Channel / 1.4MHz / QPSK

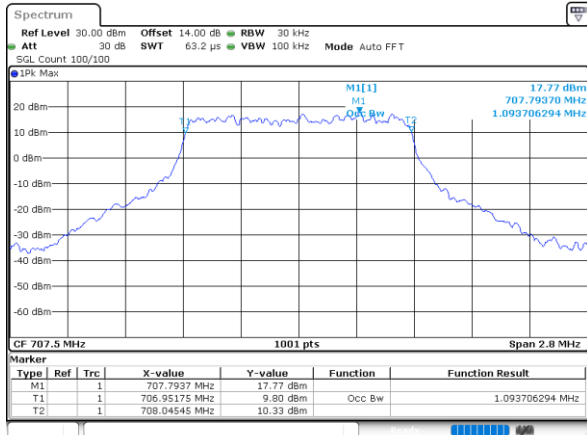

Date: 6.AUG.2024 00:24:35

Middle Channel / 1.4MHz / 16QAM

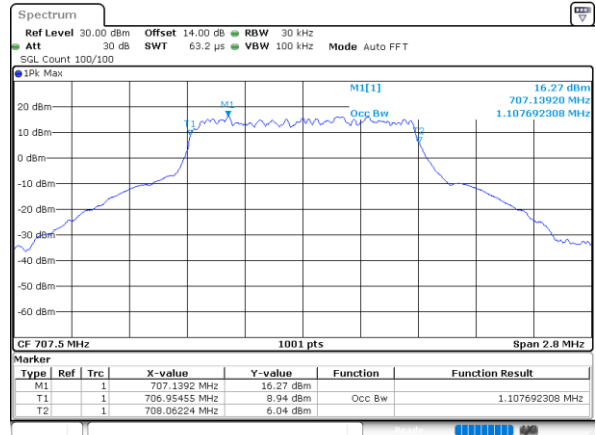

Date: 6.AUG.2024 00:25:15

Middle Channel / 3MHz / QPSK

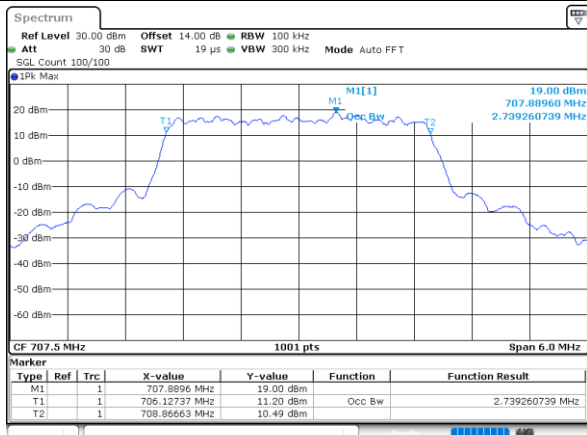

Date: 6.AUG.2024 00:43:02

Middle Channel / 3MHz / 16QAM

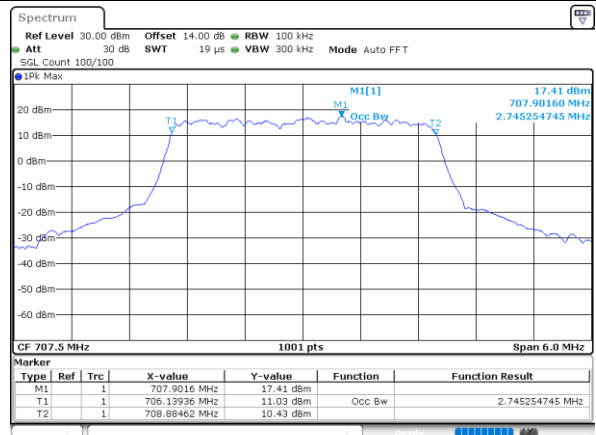

Date: 6.AUG.2024 00:43:43

Middle Channel / 5MHz / QPSK

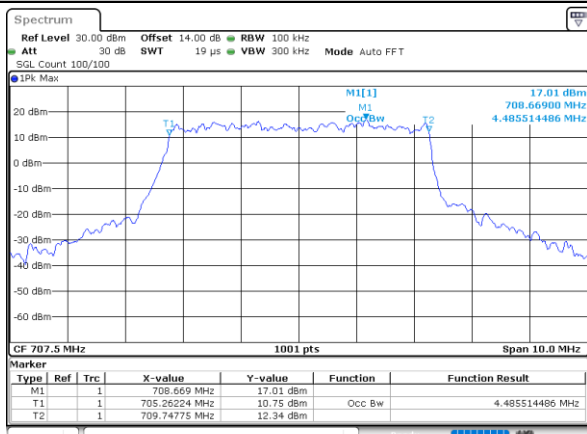

Date: 6.AUG.2024 01:01:04

Middle Channel / 5MHz / 16QAM

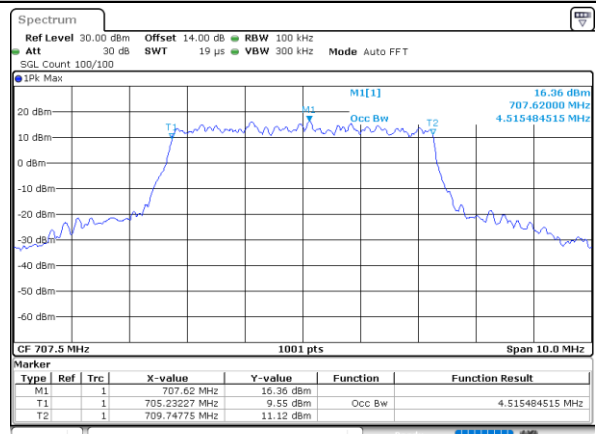

Date: 6.AUG.2024 01:01:44



LTE Band 12

Middle Channel / 10MHz / QPSK

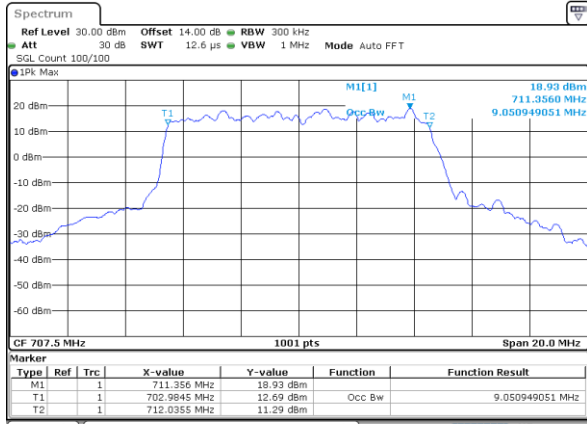

Date: 6.AUG.2024 01:18:01

Middle Channel / 10MHz / 16QAM

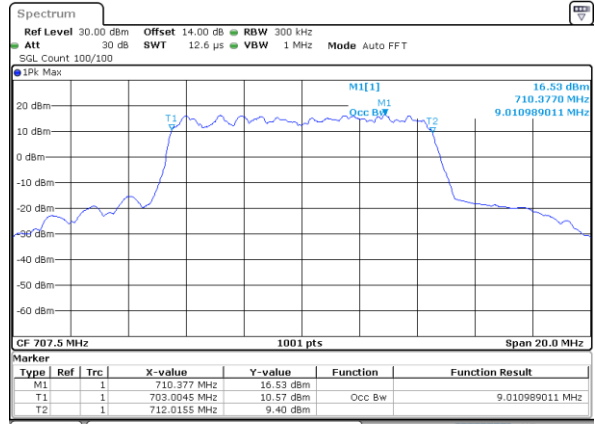

Date: 6.AUG.2024 01:18:41



Conducted Band Edge

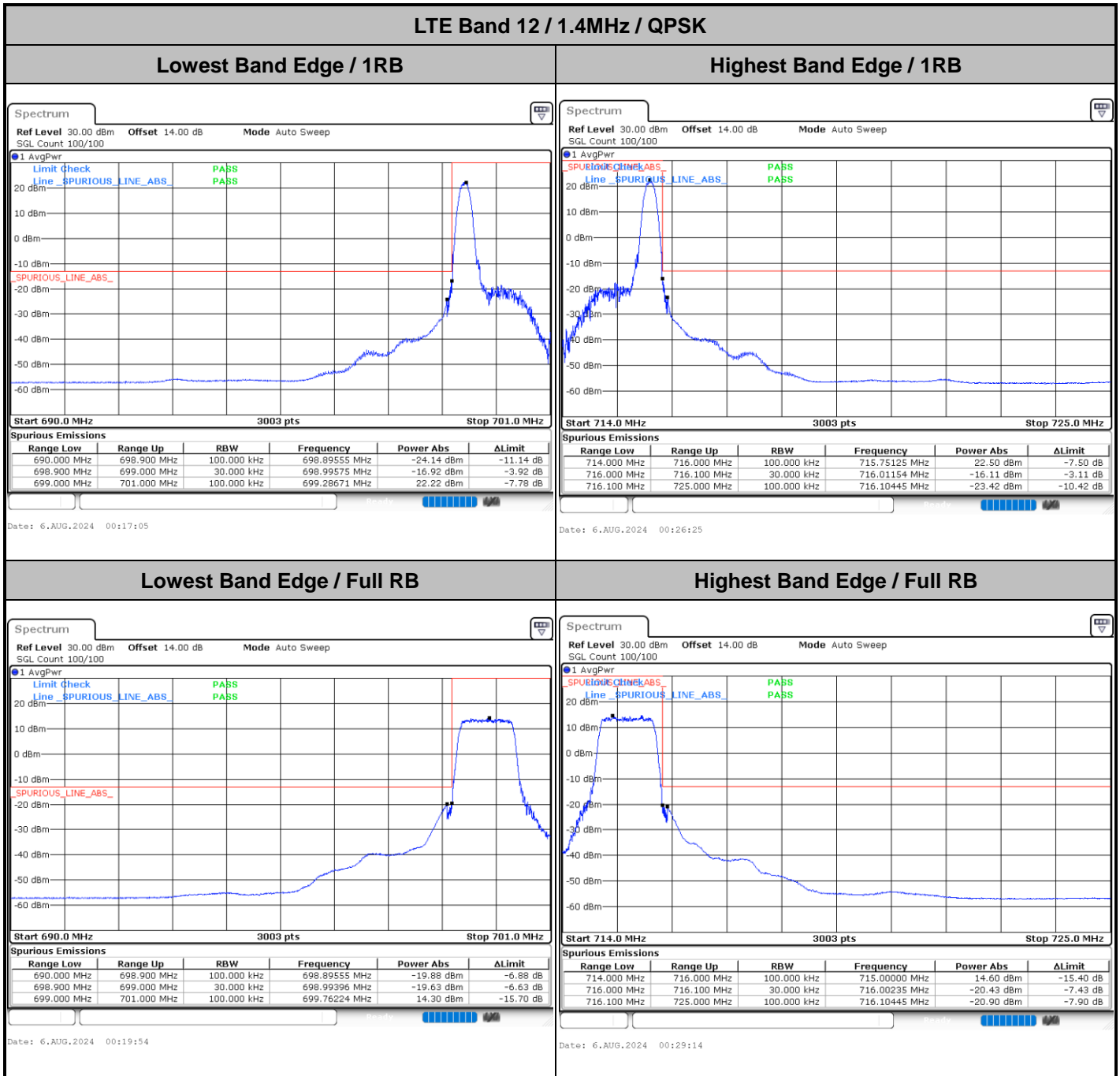



LTE Band 12 / 1.4MHz / 16QAM

Lowest Band Edge / 1 RB

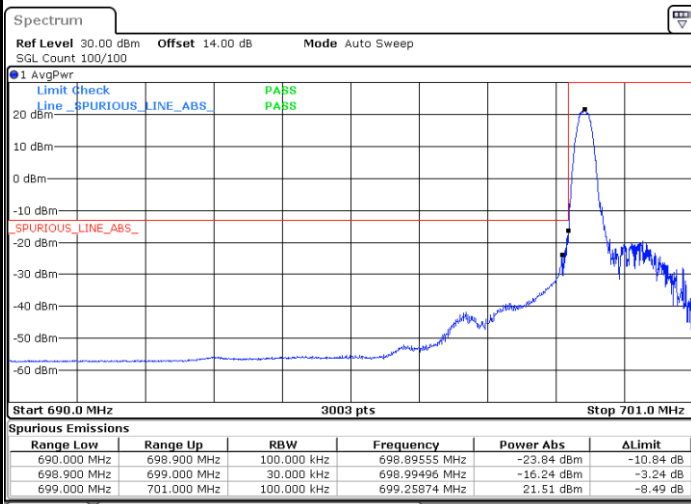

Date: 6.AUG.2024 00:18:02

Highest Band Edge / 1 RB

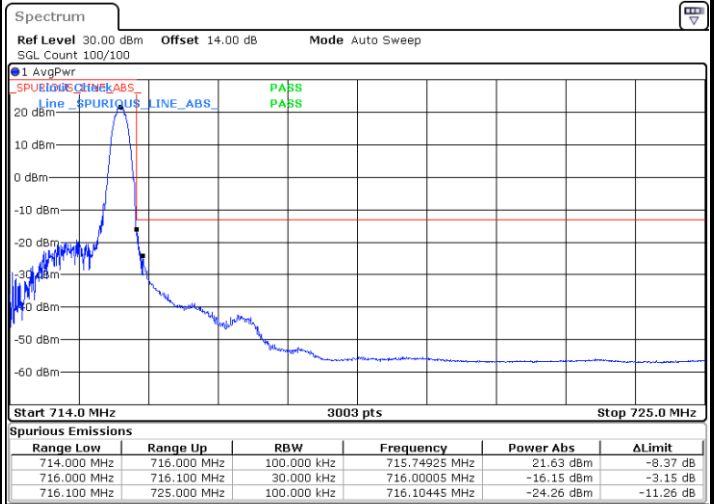

Date: 13.AUG.2024 20:29:00

Lowest Band Edge / Full RB

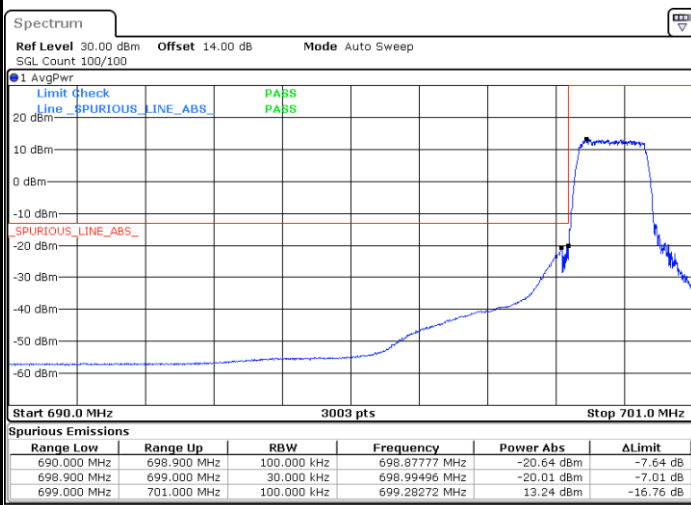

Date: 6.AUG.2024 00:20:51

Highest Band Edge / Full RB

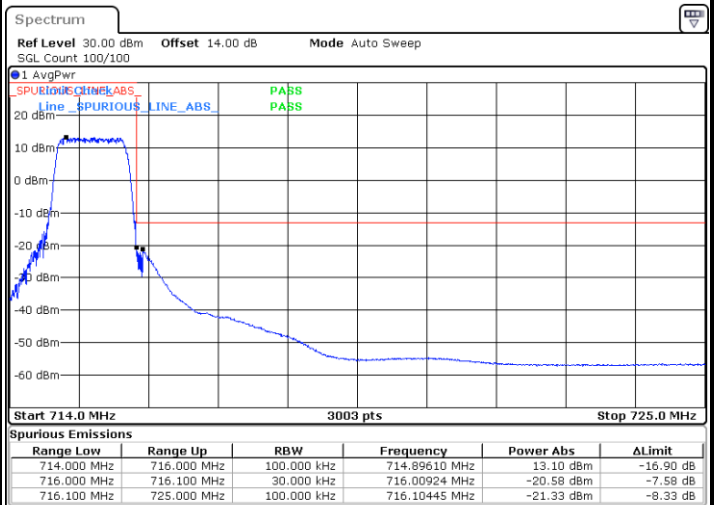

Date: 6.AUG.2024 00:30:10



LTE Band 12 / 1.4MHz / 64QAM

Lowest Band Edge / 1 RB

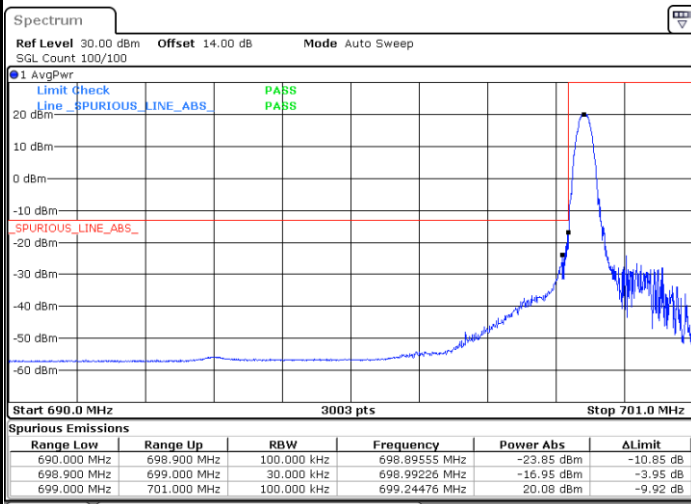

Date: 6.AUG.2024 00:18:58

Highest Band Edge / 1 RB

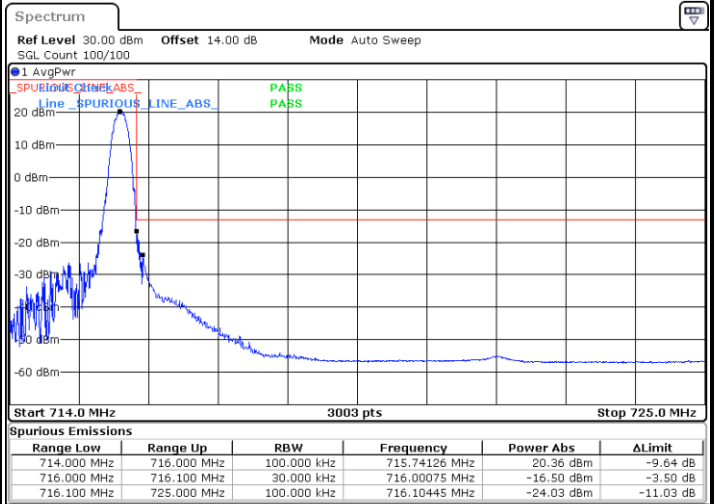

Date: 6.AUG.2024 00:28:17

Lowest Band Edge / Full RB

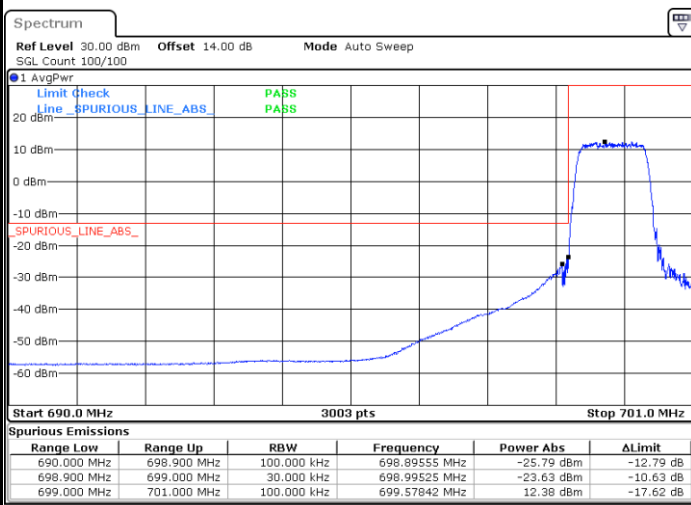

Date: 6.AUG.2024 00:21:47

Highest Band Edge / Full RB

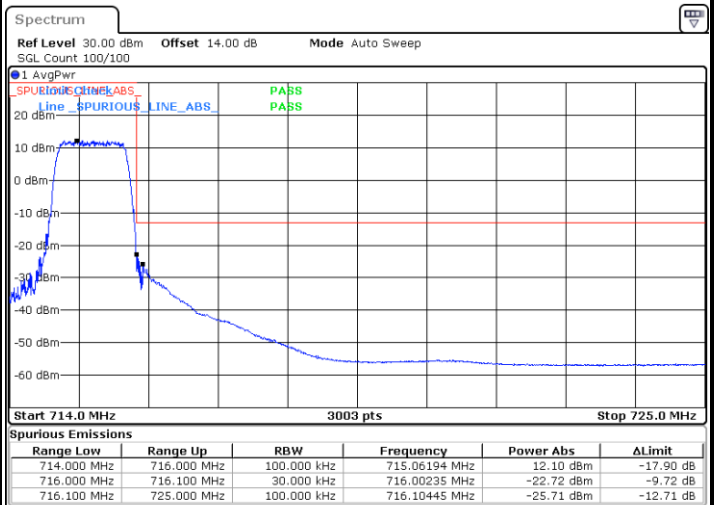

Date: 6.AUG.2024 00:31:07



LTE Band 12 / 3MHz / QPSK

Lowest Band Edge / 1RB

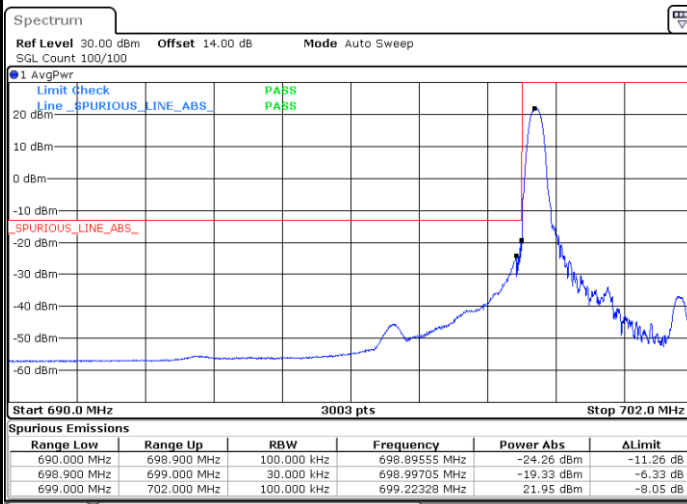

Date: 6.AUG.2024 00:35:33

Highest Band Edge / 1RB

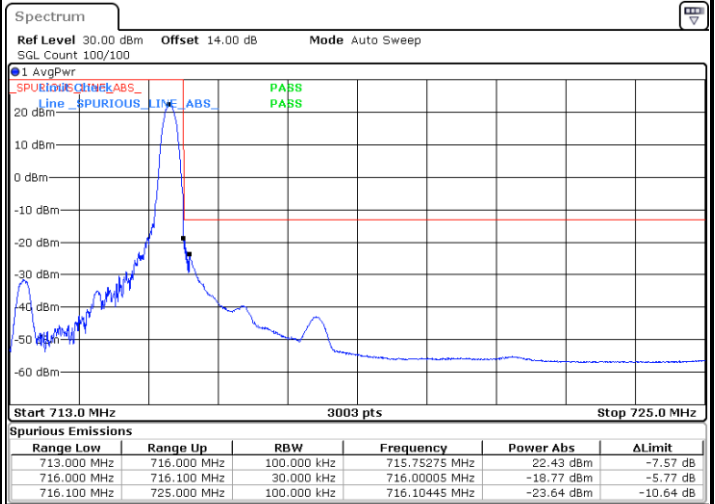

Date: 6.AUG.2024 00:44:52

Lowest Band Edge / Full RB

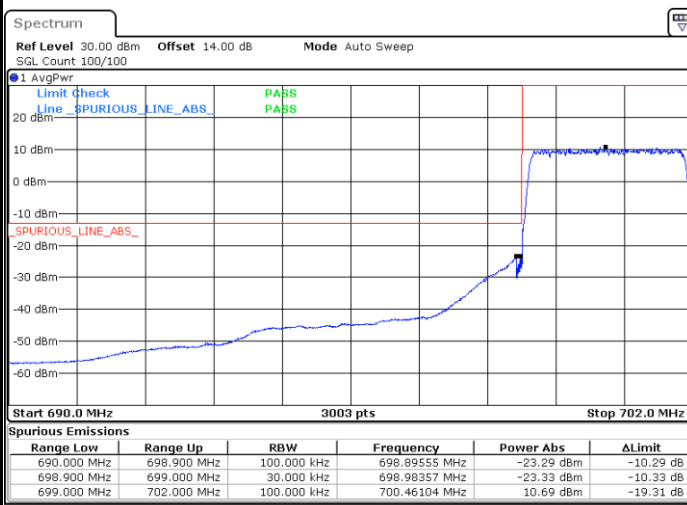

Date: 6.AUG.2024 00:38:22

Highest Band Edge / Full RB

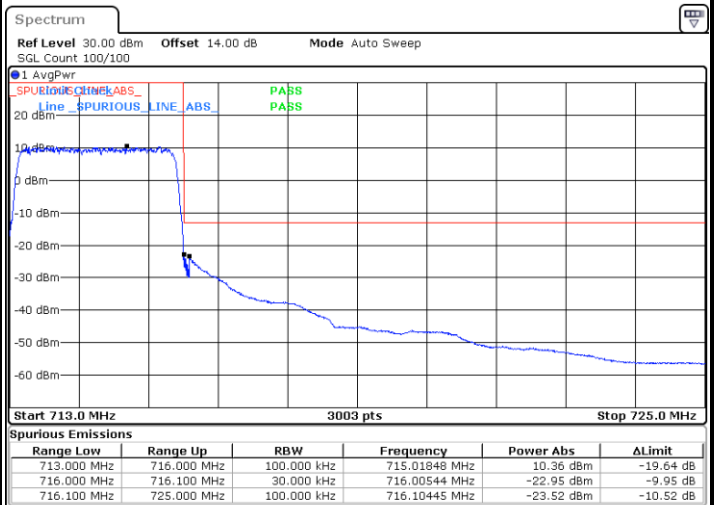

Date: 6.AUG.2024 00:47:41



LTE Band 12 / 3MHz / 16QAM

Lowest Band Edge / 1 RB

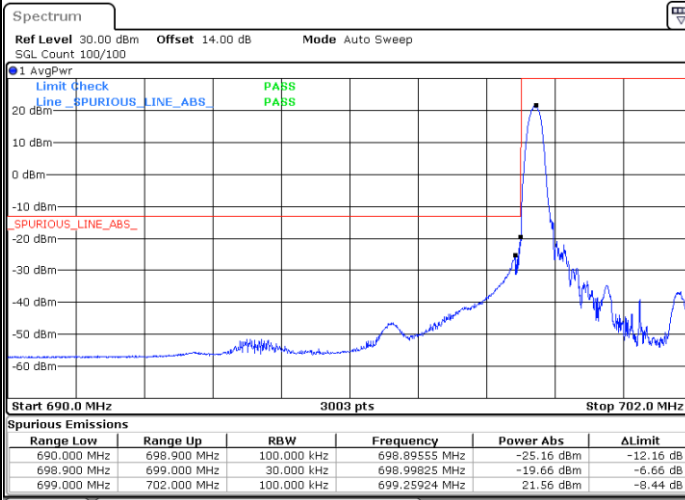

Date: 6.AUG.2024 00:36:29

Highest Band Edge / 1 RB

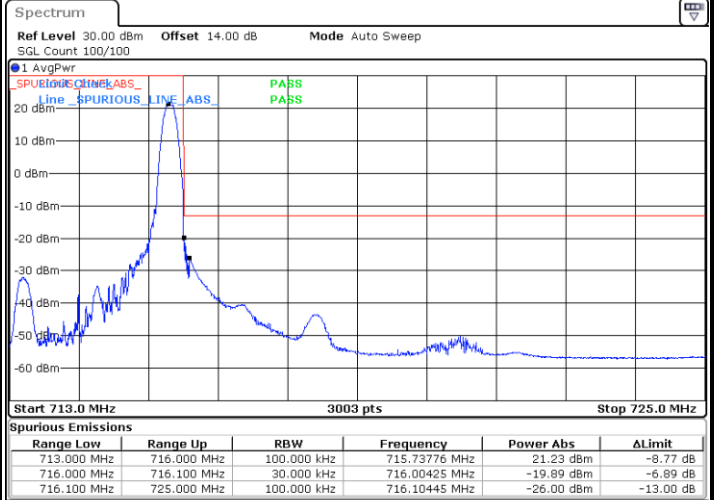

Date: 6.AUG.2024 00:45:48

Lowest Band Edge / Full RB

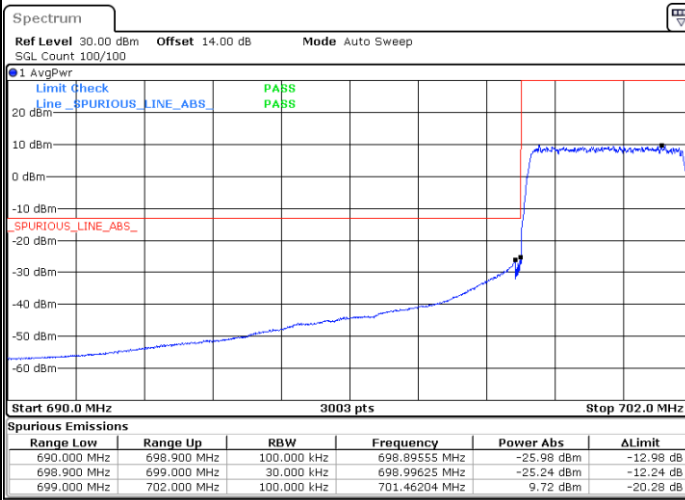

Date: 6.AUG.2024 00:39:18

Highest Band Edge / Full RB

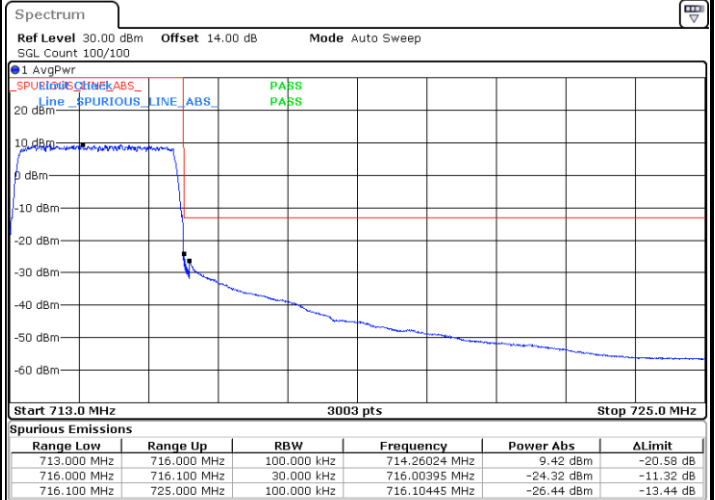

Date: 6.AUG.2024 00:48:37



LTE Band 12 / 3MHz / 64QAM

Lowest Band Edge / 1 RB

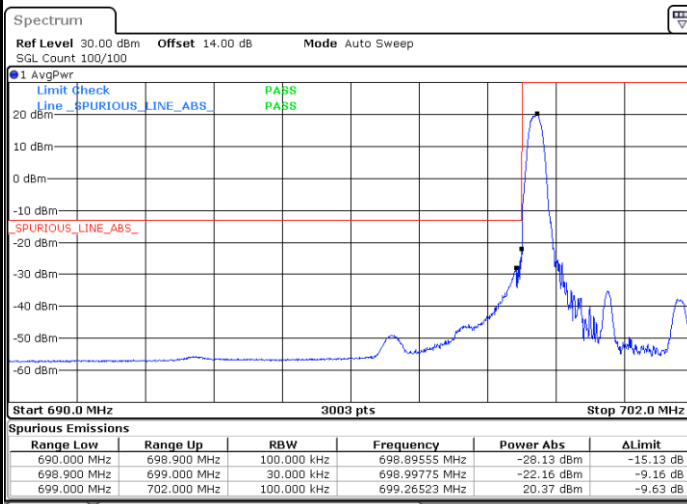

Date: 6.AUG.2024 00:37:25

Highest Band Edge / 1 RB

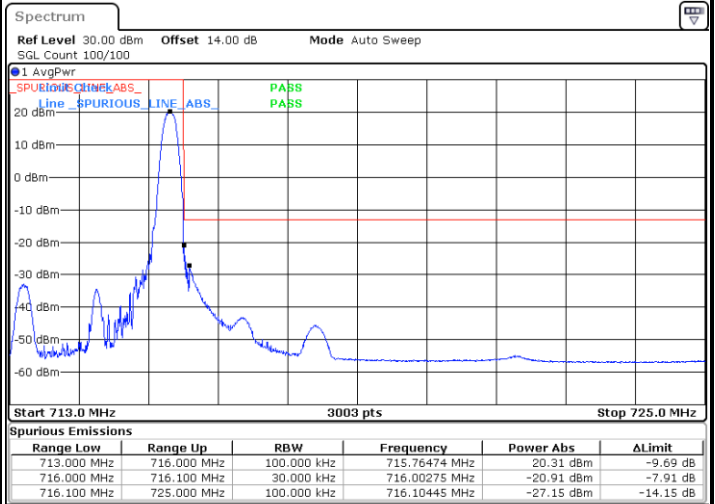

Date: 6.AUG.2024 00:46:44

Lowest Band Edge / Full RB

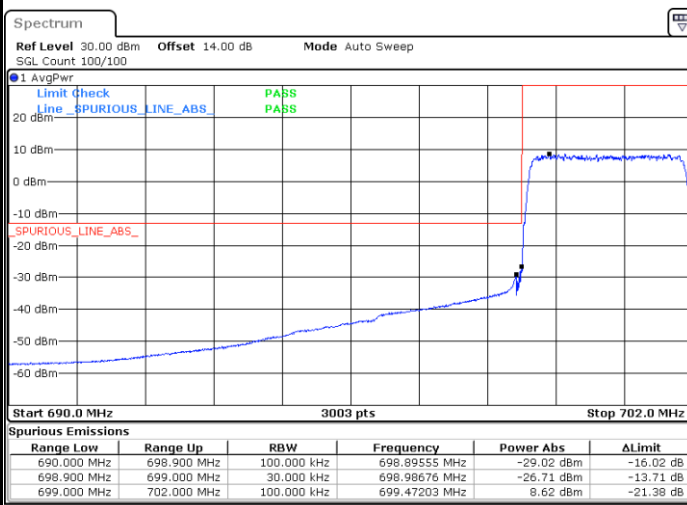

Date: 6.AUG.2024 00:40:15

Highest Band Edge / Full RB

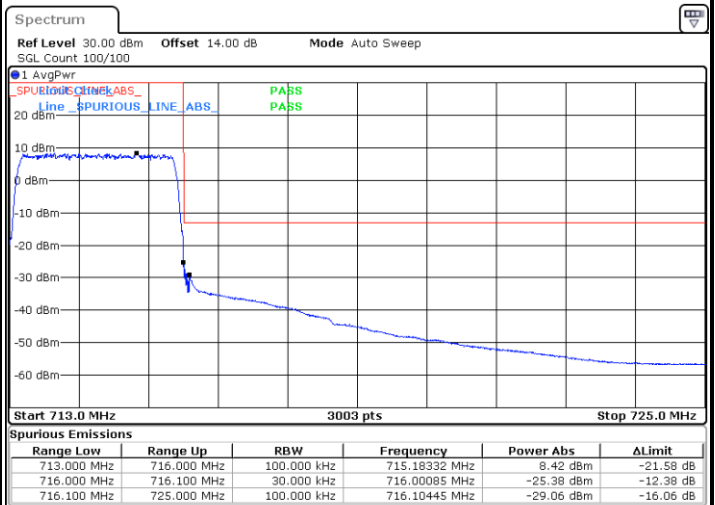

Date: 6.AUG.2024 00:49:33



LTE Band 12 / 5MHz / QPSK

Lowest Band Edge / 1RB

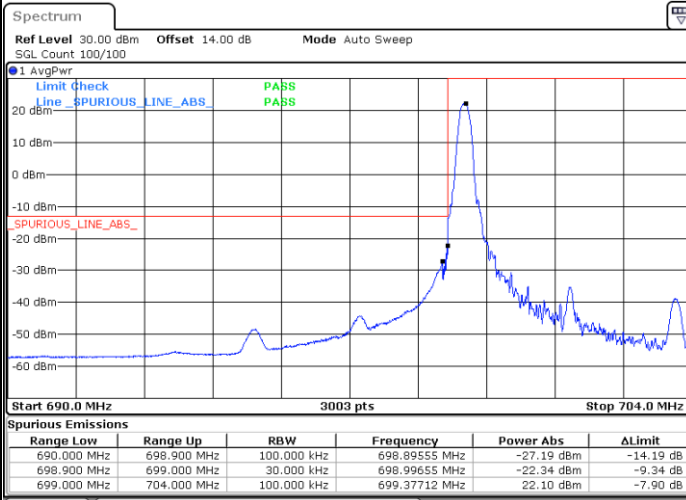

Date: 6.AUG.2024 00:53:35

Highest Band Edge / 1RB

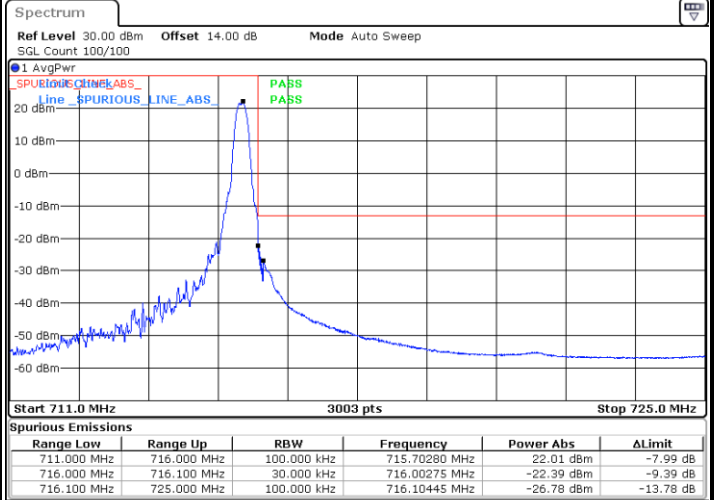

Date: 6.AUG.2024 01:02:54

Lowest Band Edge / Full RB

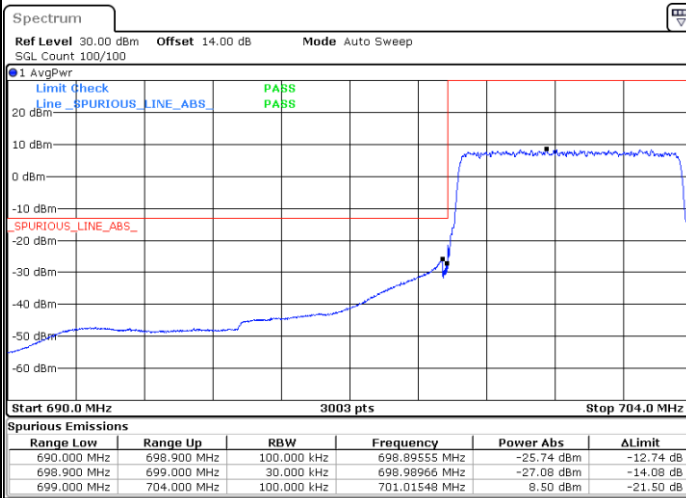

Date: 6.AUG.2024 00:56:24

Highest Band Edge / Full RB

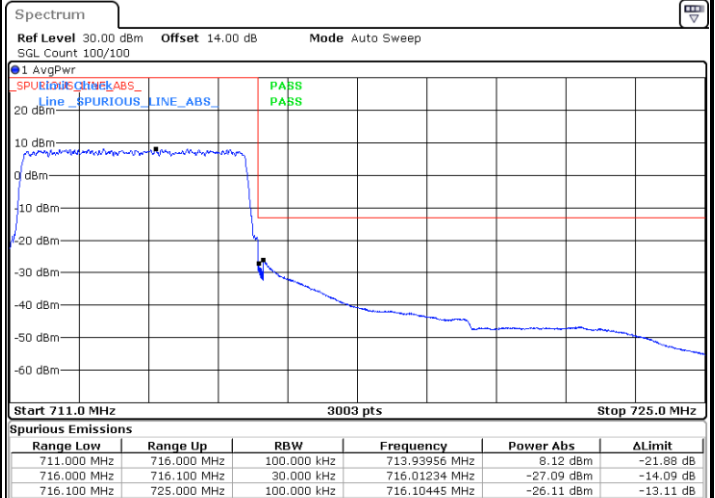

Date: 6.AUG.2024 01:05:43



LTE Band 12 / 5MHz / 16QAM

Lowest Band Edge / 1 RB

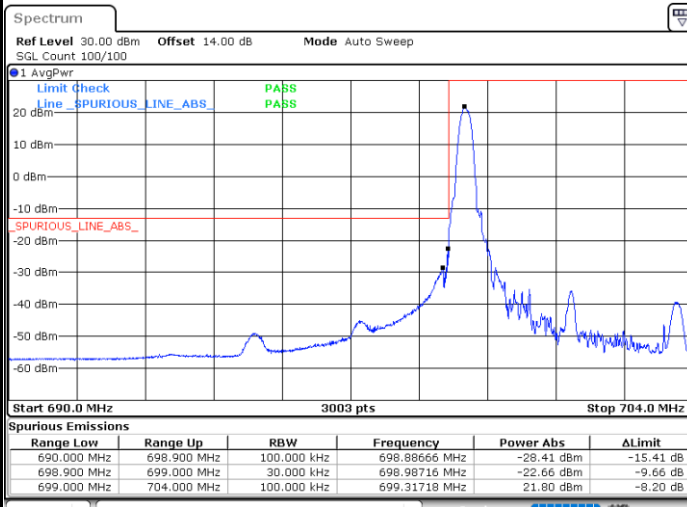

Date: 6.AUG.2024 00:54:31

Highest Band Edge / 1 RB

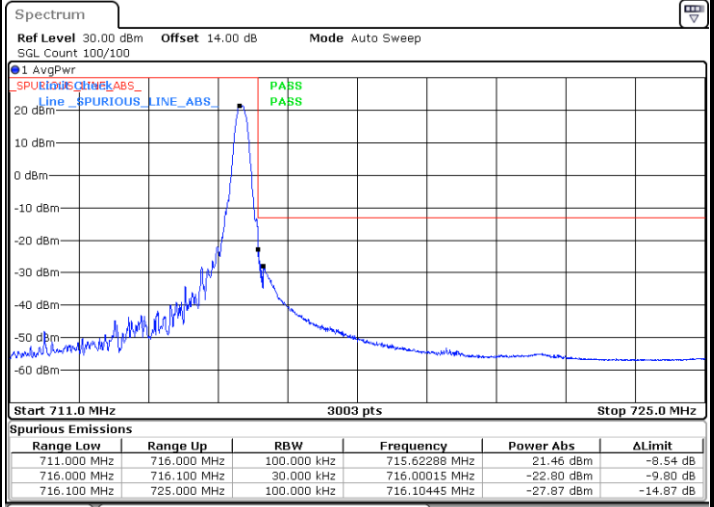

Date: 6.AUG.2024 01:03:50

Lowest Band Edge / Full RB

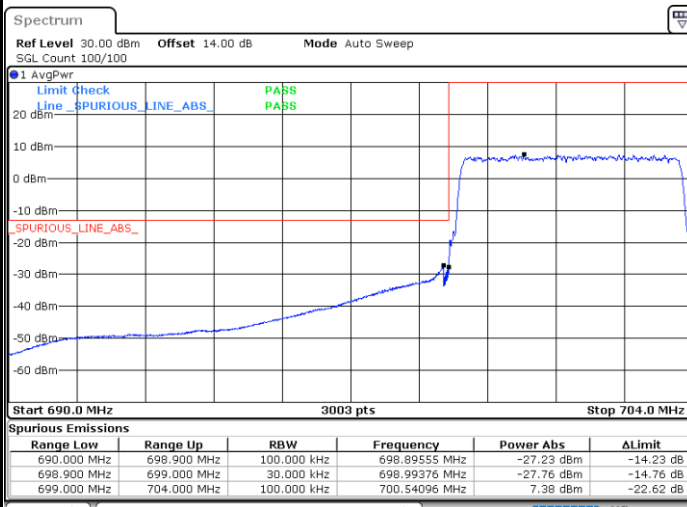

Date: 6.AUG.2024 00:57:20

Highest Band Edge / Full RB

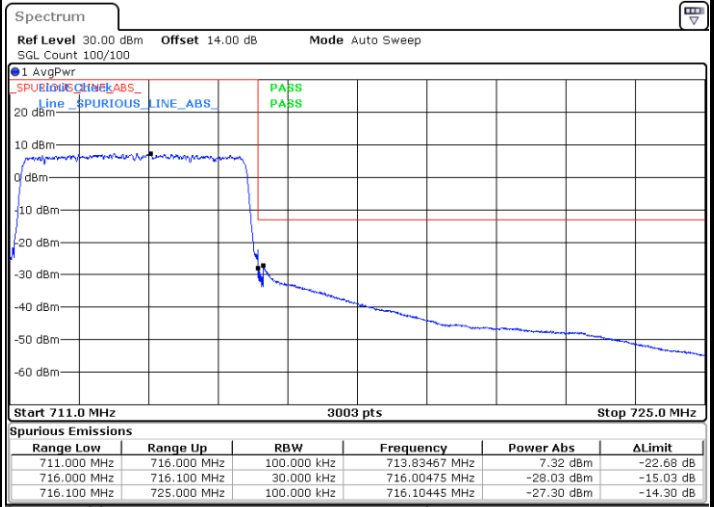

Date: 6.AUG.2024 01:06:39



LTE Band 12 / 5MHz / 64QAM

Lowest Band Edge / 1 RB

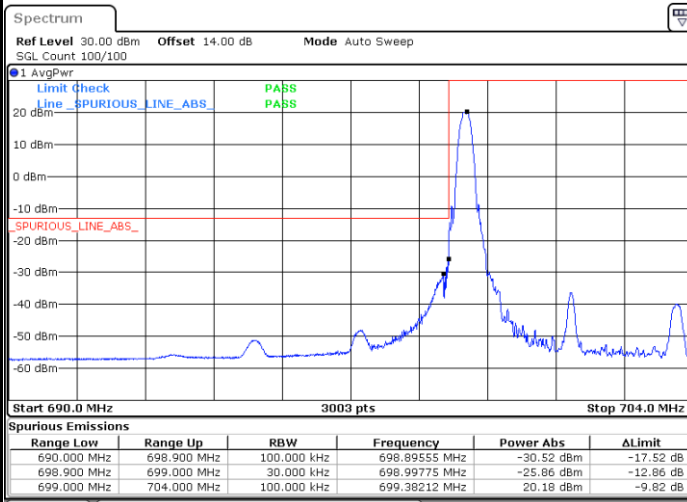

Date: 6.AUG.2024 00:55:27

Highest Band Edge / 1 RB

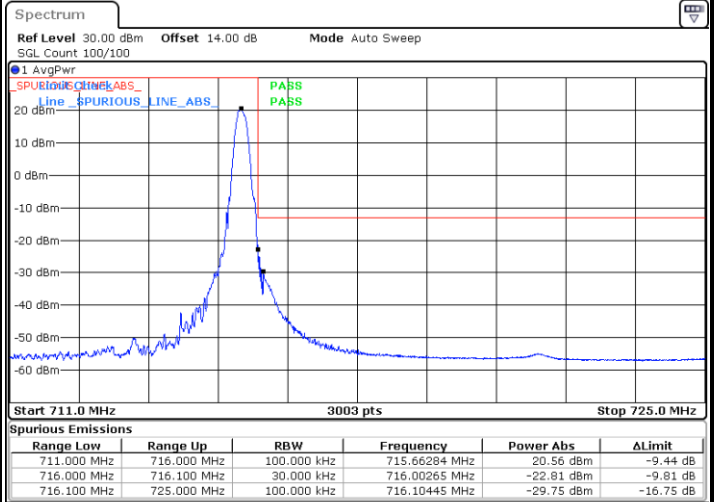

Date: 6.AUG.2024 01:04:46

Lowest Band Edge / Full RB

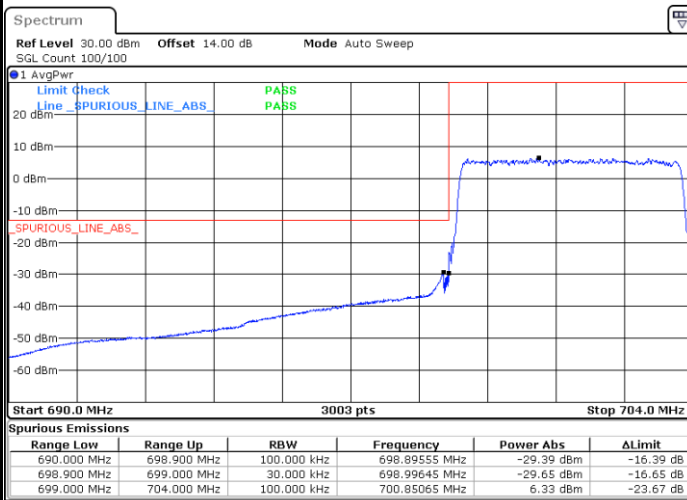

Date: 6.AUG.2024 00:58:17

Highest Band Edge / Full RB

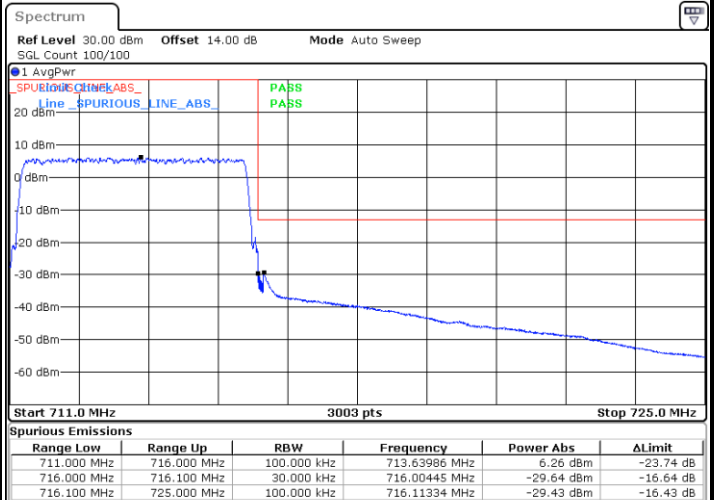

Date: 6.AUG.2024 01:07:35



LTE Band 12 / 10MHz / QPSK

Lowest Band Edge / 1RB

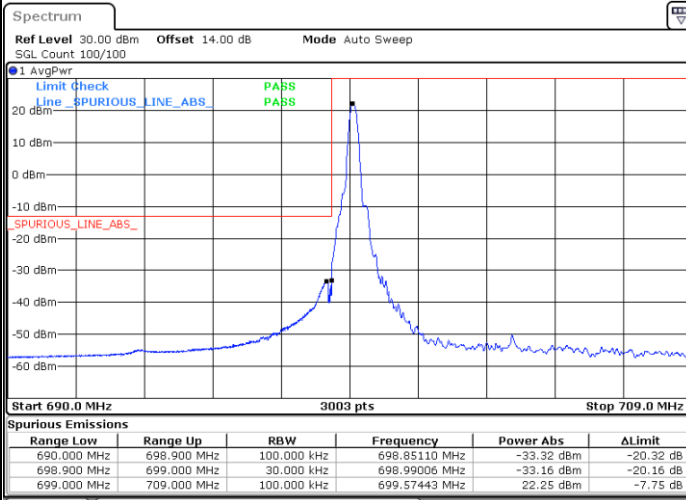

Date: 6.AUG.2024 01:10:30

Highest Band Edge / 1RB

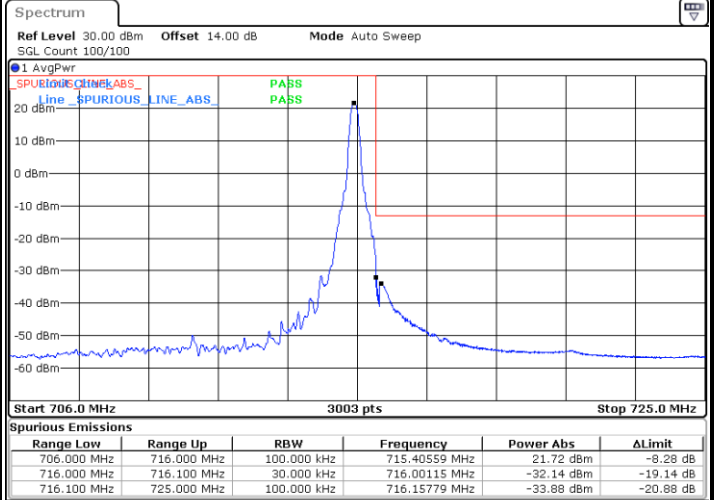

Date: 6.AUG.2024 01:19:50

Lowest Band Edge / Full RB

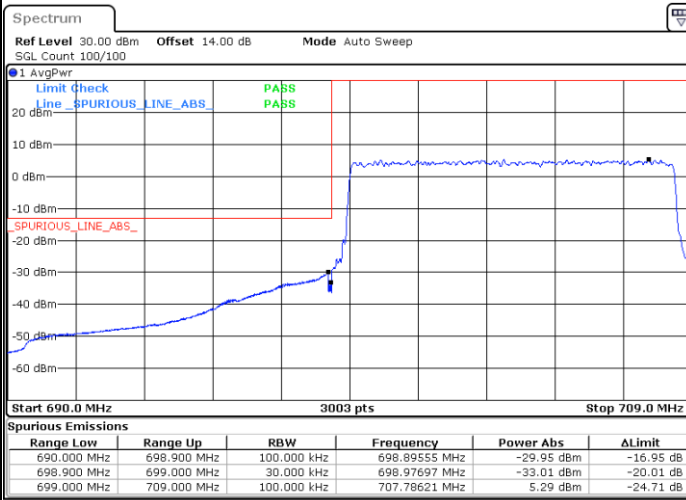

Date: 6.AUG.2024 01:13:20

Highest Band Edge / Full RB

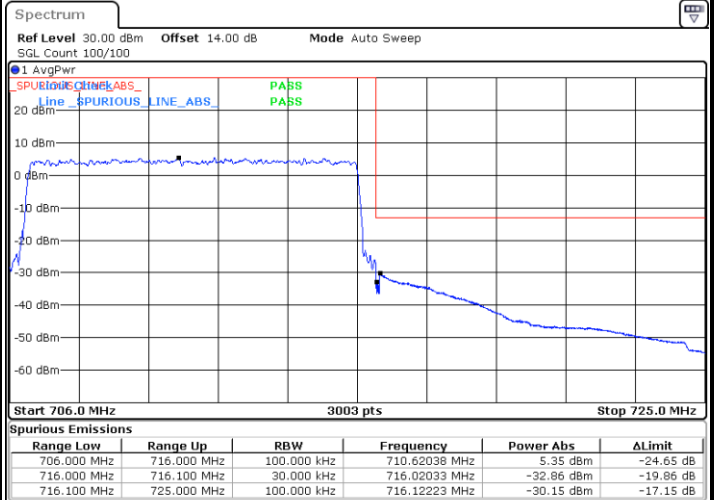

Date: 6.AUG.2024 01:22:40



LTE Band 12 / 10MHz / 16QAM

Lowest Band Edge / 1 RB

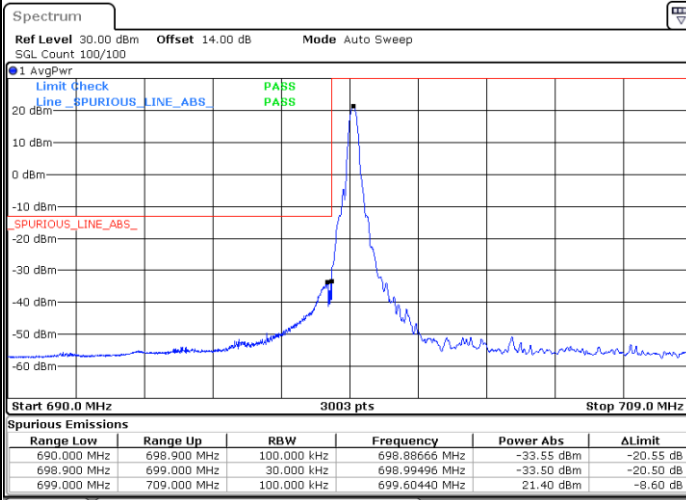

Date: 6.AUG.2024 01:11:27

Highest Band Edge / 1 RB

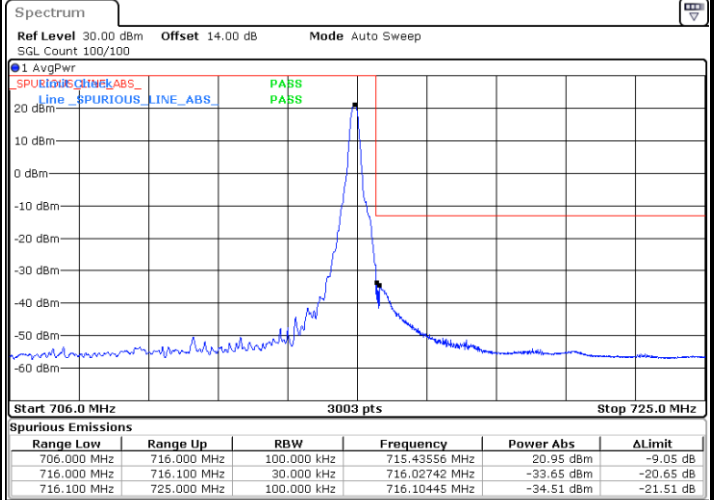

Date: 6.AUG.2024 01:20:47

Lowest Band Edge / Full RB

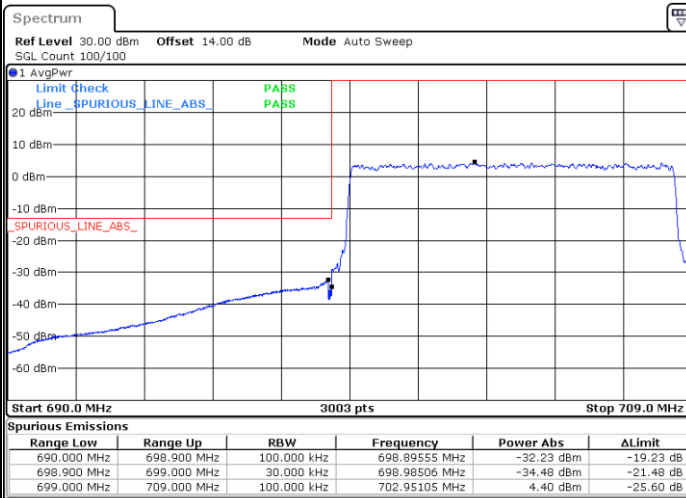

Date: 6.AUG.2024 01:14:16

Highest Band Edge / Full RB

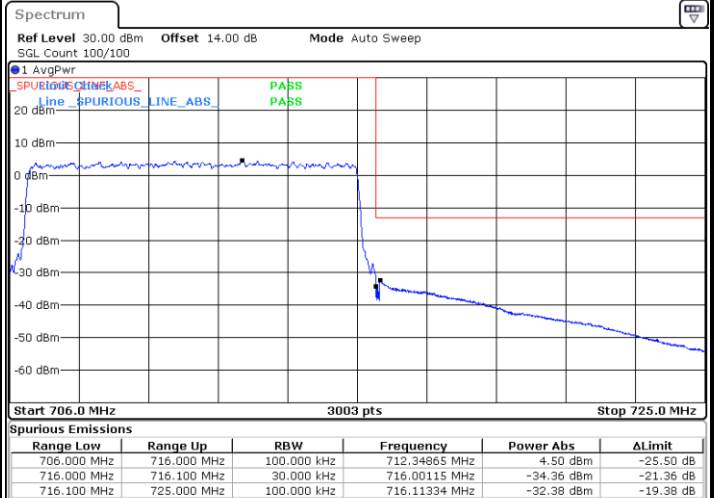

Date: 6.AUG.2024 01:23:36



LTE Band 12 / 10MHz / 64QAM

Lowest Band Edge / 1 RB

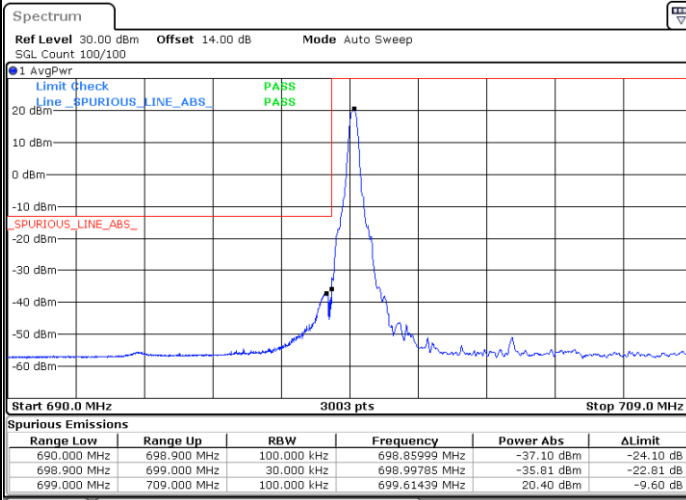

Date: 6.AUG.2024 01:12:23

Highest Band Edge / 1 RB

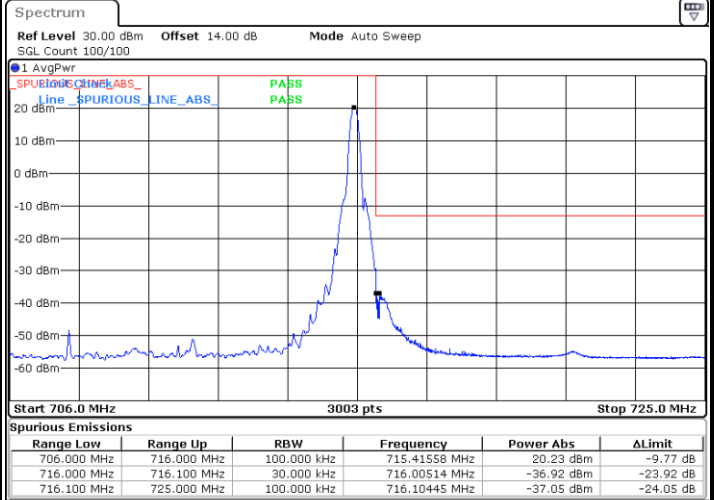

Date: 6.AUG.2024 01:21:43

Lowest Band Edge / Full RB

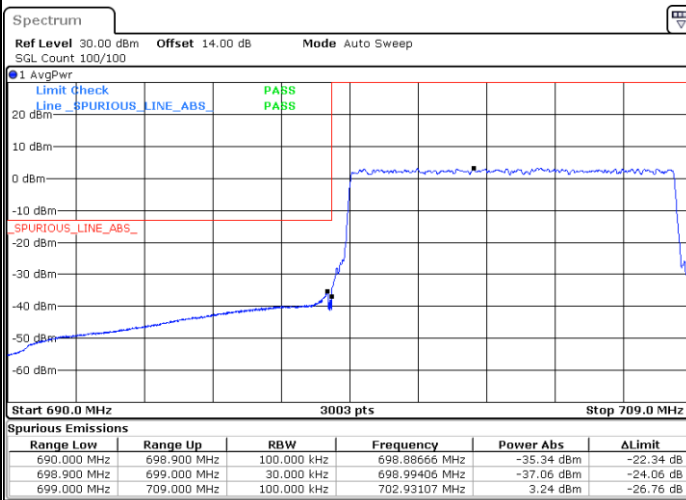

Date: 6.AUG.2024 01:15:13

Highest Band Edge / Full RB

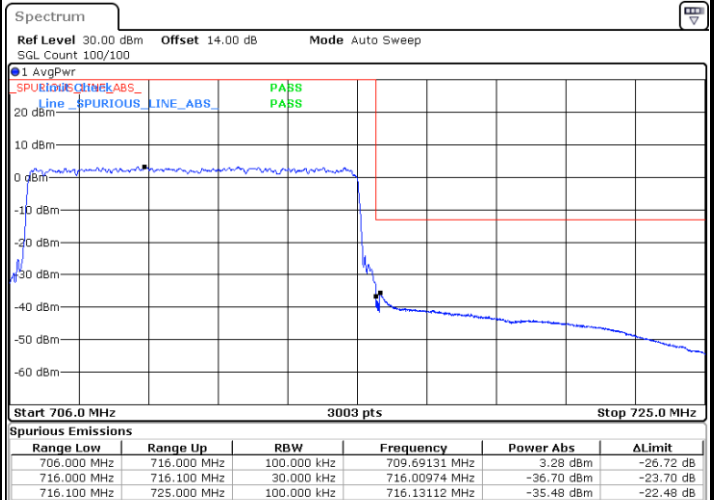

Date: 6.AUG.2024 01:24:33



Conducted Spurious Emission

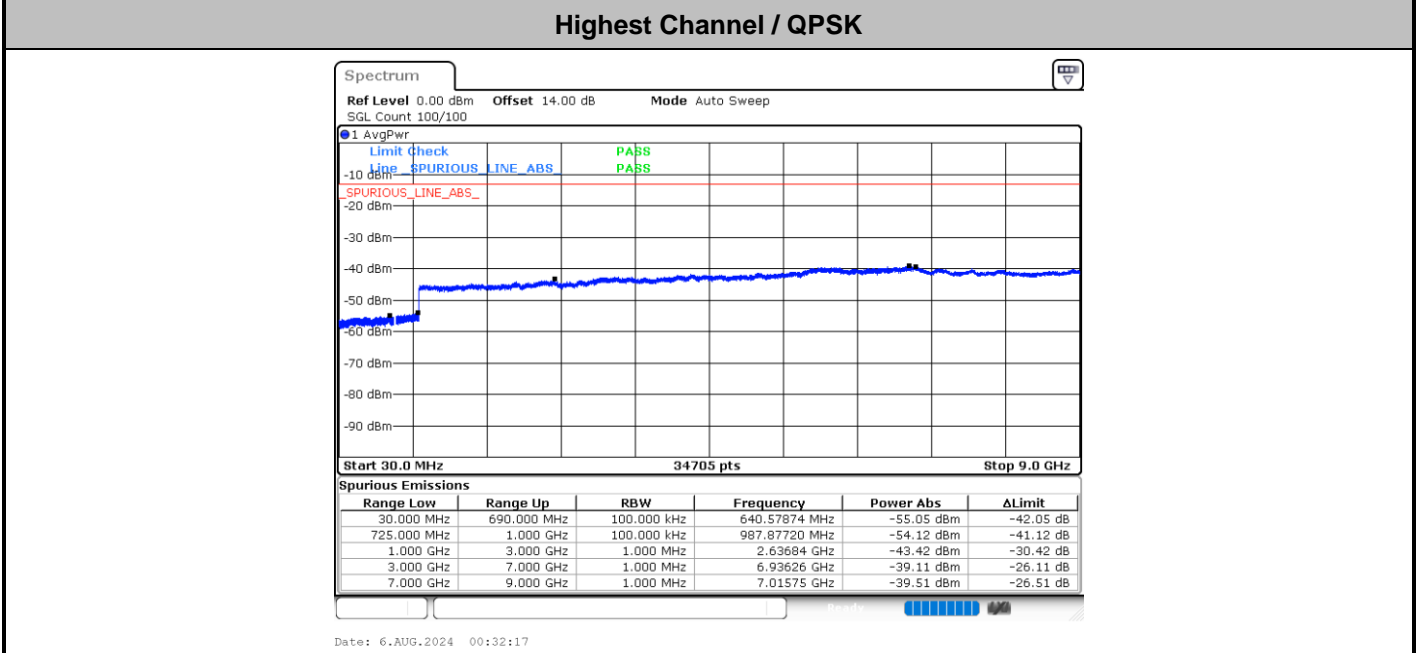
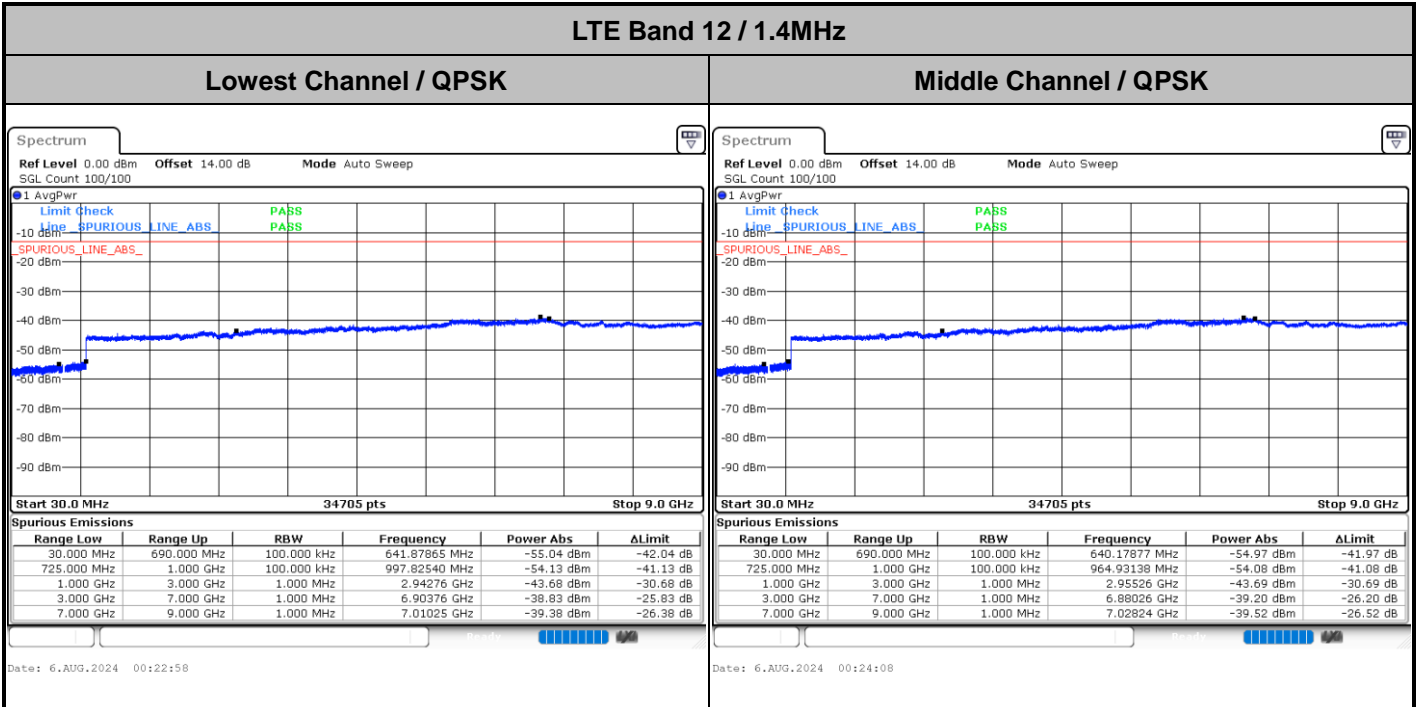



LTE Band 12 / 3MHz

Lowest Channel / QPSK

Middle Channel / QPSK

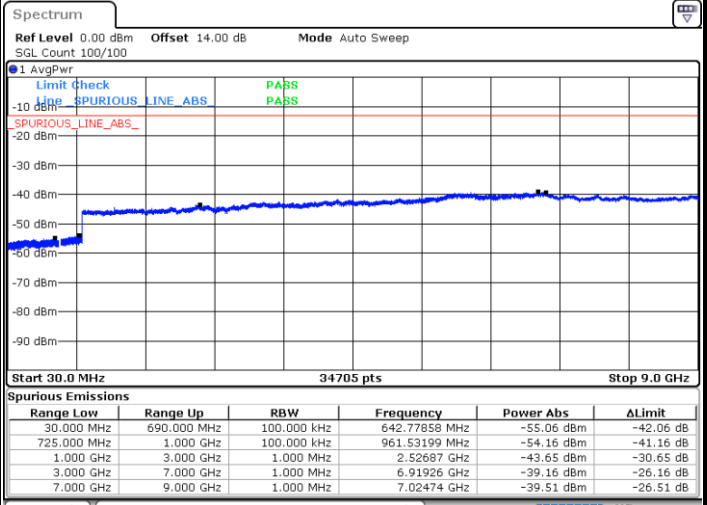
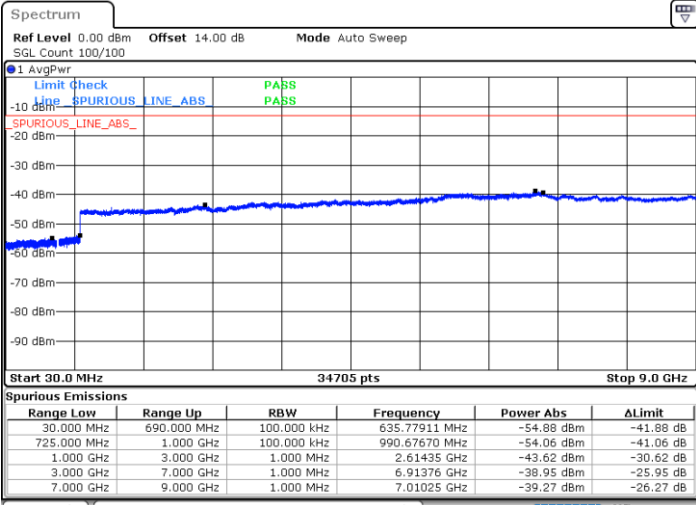

Date: 6.AUG.2024 00:41:25

Date: 6.AUG.2024 00:42:35

Highest Channel / QPSK

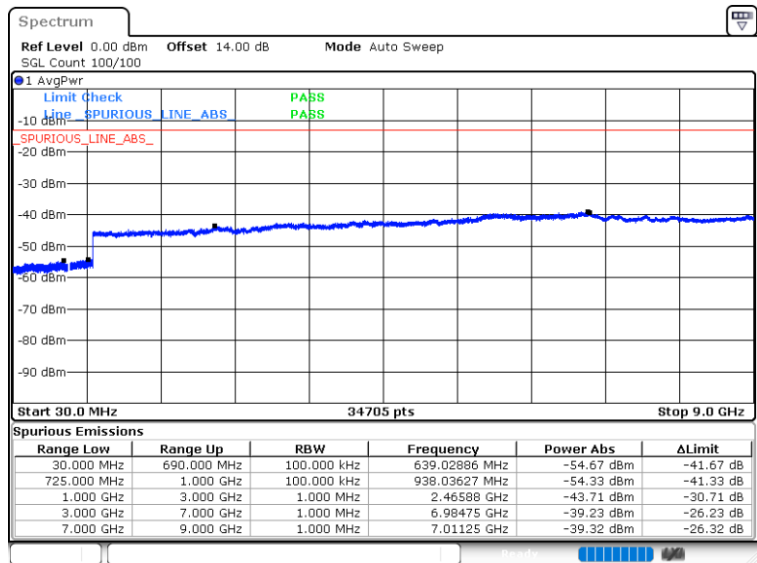

Date: 6.AUG.2024 00:50:44



LTE Band 12 / 5MHz

Lowest Channel / QPSK

Middle Channel / QPSK

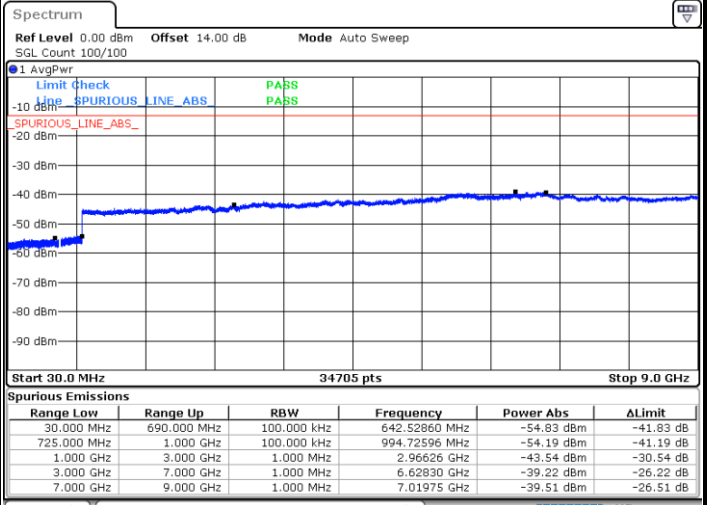
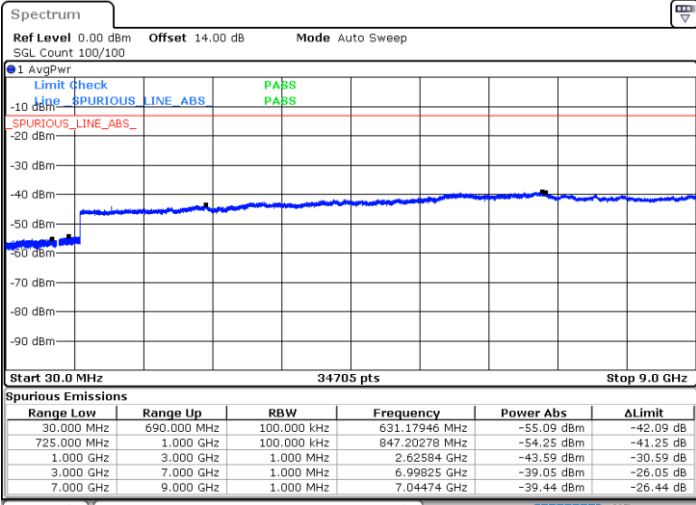

Date: 6.AUG.2024 00:59:27

Date: 6.AUG.2024 01:00:37

Highest Channel / QPSK

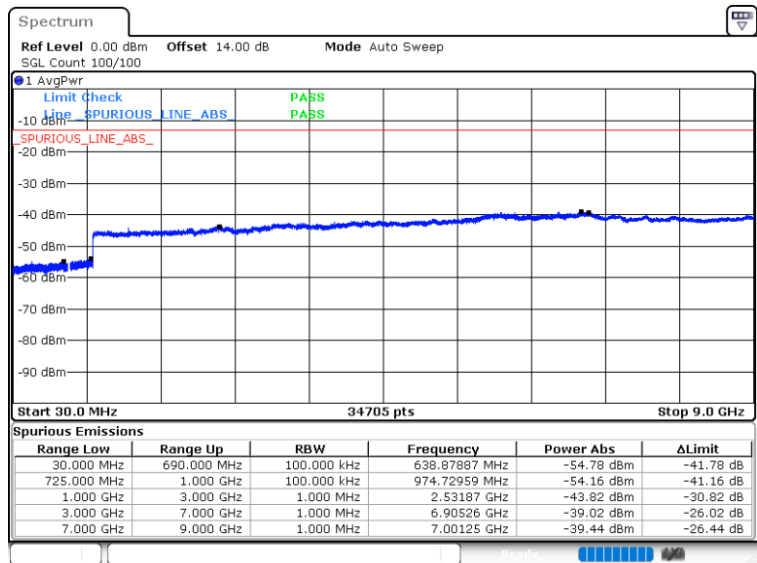

Date: 6.AUG.2024 01:08:46



LTE Band 12 / 10MHz

Lowest Channel / QPSK

Middle Channel / QPSK

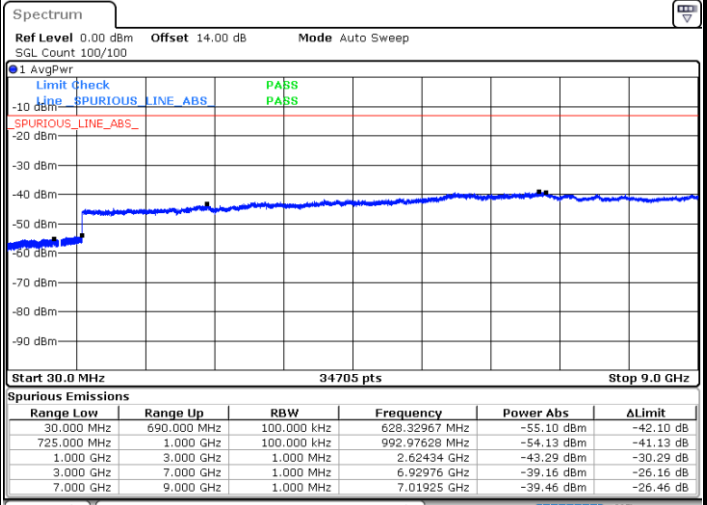
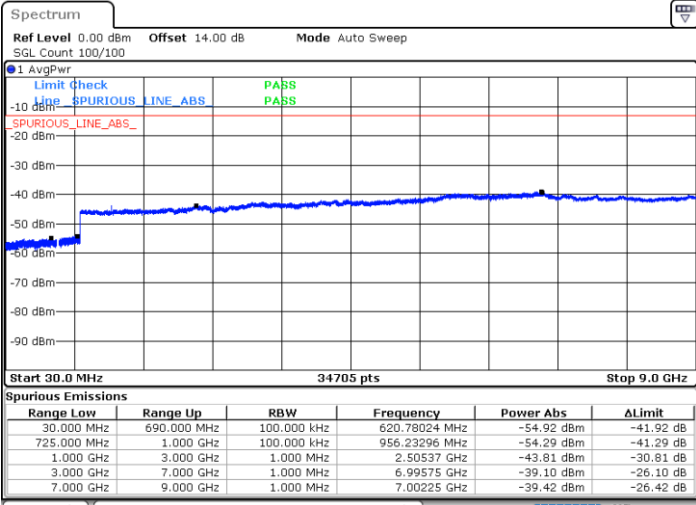

Date: 6.AUG.2024 01:16:24

Date: 6.AUG.2024 01:17:34

Highest Channel / QPSK

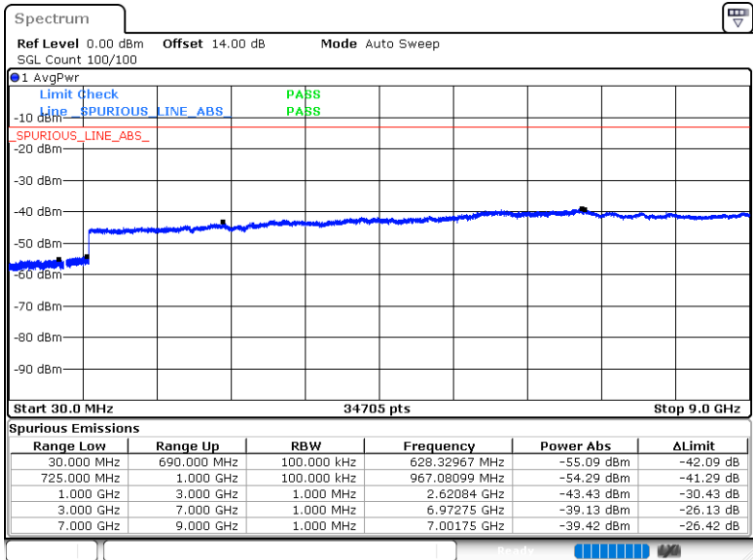

Date: 6.AUG.2024 01:25:43



Frequency Stability

Test Conditions		LTE Band 12 (QPSK) / Middle Channel	Limit
Temperature (°C)	Voltage (Volt)	BW 10MHz	Note 2.
		Deviation (ppm)	Result
50	Normal Voltage	0.0017	PASS
40	Normal Voltage	0.0001	
30	Normal Voltage	0.0007	
20(Ref.)	Normal Voltage	0.0000	
10	Normal Voltage	0.0001	
0	Normal Voltage	0.0014	
-10	Normal Voltage	0.0003	
-20	Normal Voltage	0.0004	
-30	Normal Voltage	0.0008	
20	Maximum Voltage	0.0007	
20	Normal Voltage	0.0000	
20	Battery End Point	0.0010	

Note:

1. Normal Voltage = 8.0 V. ; Battery End Point (BEP) = 7.2 V. ; Maximum Voltage = 9.0 V.
2. The frequency fundamental emissions stay within the authorized frequency block.



LTE Band 13

Peak-to-Average Ratio

Mode	LTE Band 13 / 10MHz			
Mod.	QPSK	16QAM	64QAM	Limit: 13dB
RB Size	Full RB	Full RB	Full RB	Result
Middle CH	4.43	5.51	6.32	PASS



LTE Band 13 / 10MHz / QPSK

Middle Channel / Full RB

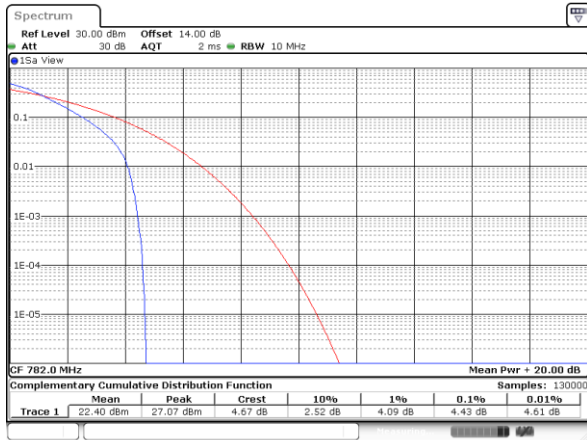

Date: 6.AUG.2024 01:55:56

LTE Band 13 / 10MHz / 16QAM

Middle Channel / Full RB

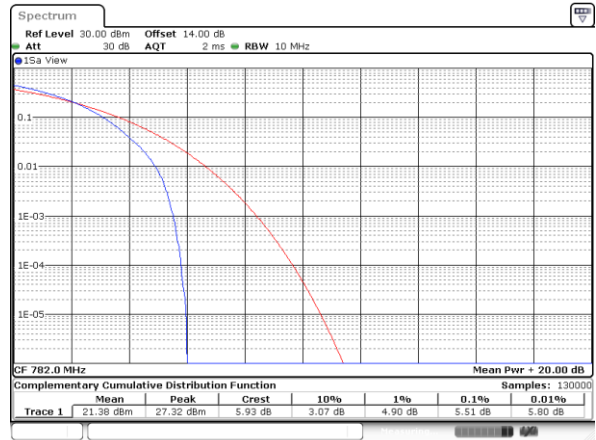

Date: 6.AUG.2024 01:56:24

LTE Band 13 / 10MHz / 64QAM

Middle Channel / Full RB

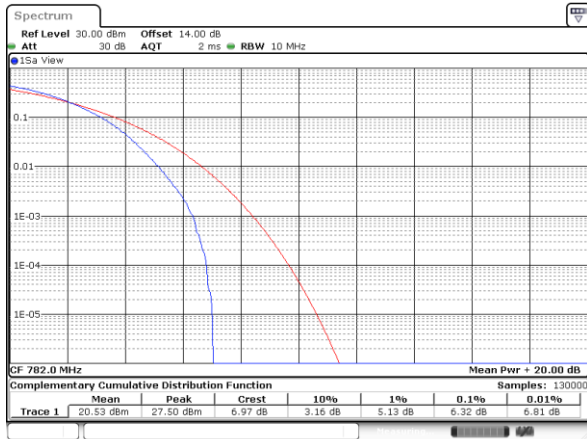

Date: 6.AUG.2024 01:56:52



26dB Bandwidth

Mode	LTE Band 13 : 26dB BW(MHz)											
	1.4MHz		3MHz		5MHz		10MHz		15MHz		20MHz	
Mod.	QPSK	16QAM	QPSK	16QAM	QPSK	16QAM	QPSK	16QAM	QPSK	16QAM	QPSK	16QAM
Middle CH	-	-	-	-	5.00	5.01	9.71	10.01	-	-	-	-



LTE Band 13

Middle Channel / 5MHz / QPSK

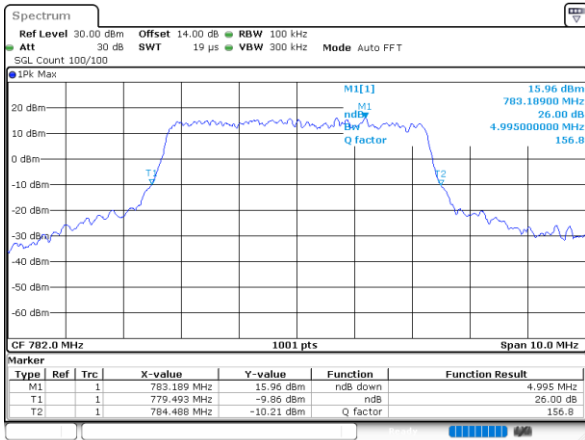

Date: 6.AUG.2024 01:13:20

Middle Channel / 5MHz / 16QAM

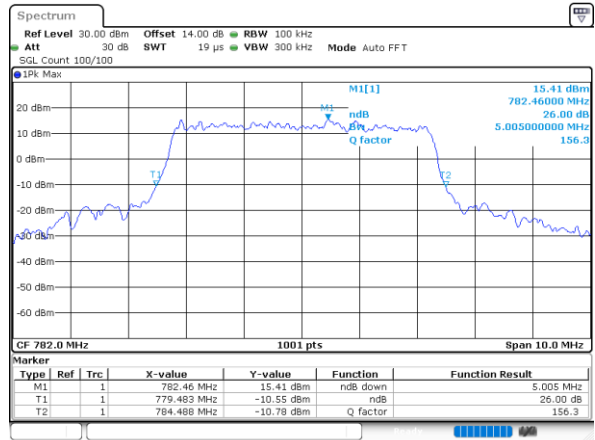

Date: 6.AUG.2024 01:13:00

Middle Channel / 10MHz / QPSK

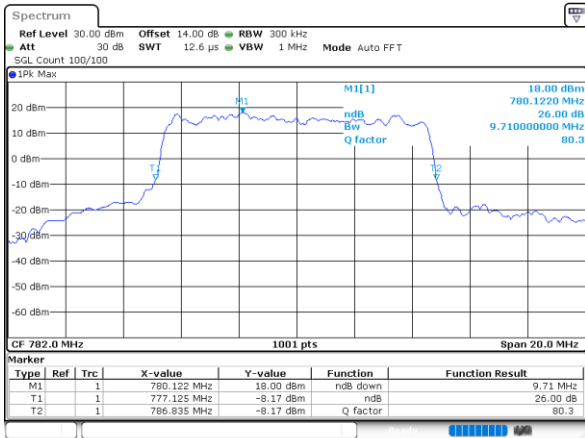

Date: 6.AUG.2024 01:14:49

Middle Channel / 10MHz / 16QAM

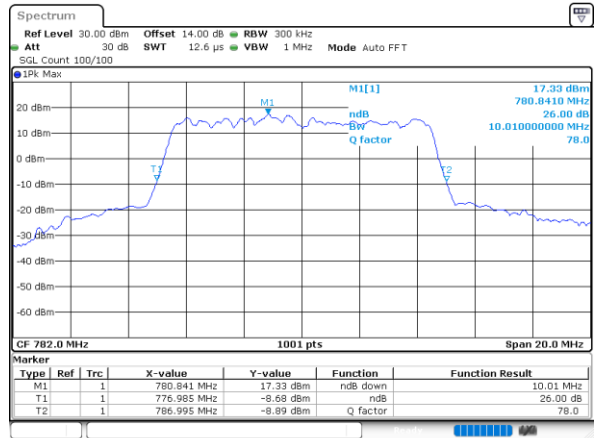

Date: 6.AUG.2024 01:55:29



Occupied Bandwidth

Mode	LTE Band 13 : 99%OBW(MHz)											
	1.4MHz		3MHz		5MHz		10MHz		15MHz		20MHz	
Mod.	QPSK	16QAM	QPSK	16QAM	QPSK	16QAM	QPSK	16QAM	QPSK	16QAM	QPSK	16QAM
Middle CH	-	-	-	-	4.49	4.50	9.01	9.01	-	-	-	-



LTE Band 13

Middle Channel / 5MHz / QPSK

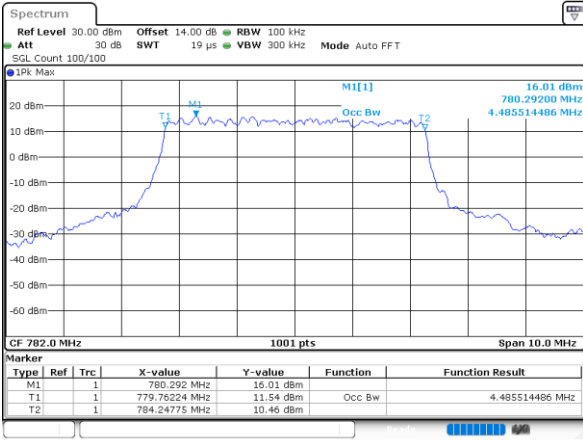

Date: 6.AUG.2024 01:36:06

Middle Channel / 5MHz / 16QAM

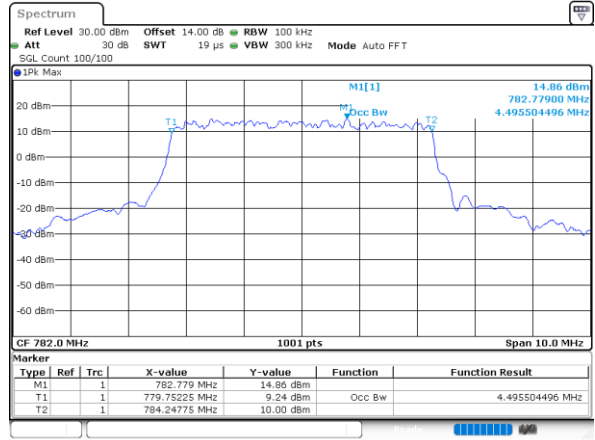

Date: 6.AUG.2024 01:36:46

Middle Channel / 10MHz / QPSK

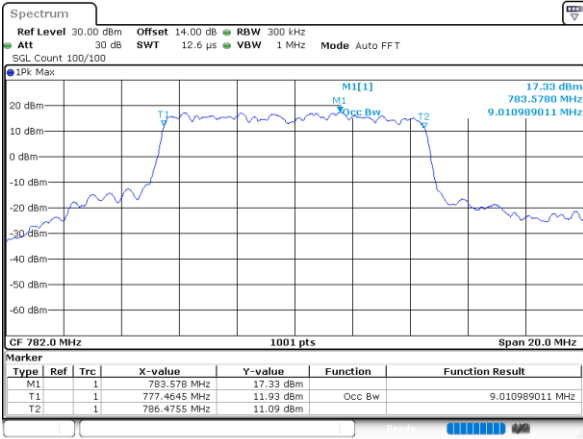

Date: 6.AUG.2024 01:54:35

Middle Channel / 10MHz / 16QAM

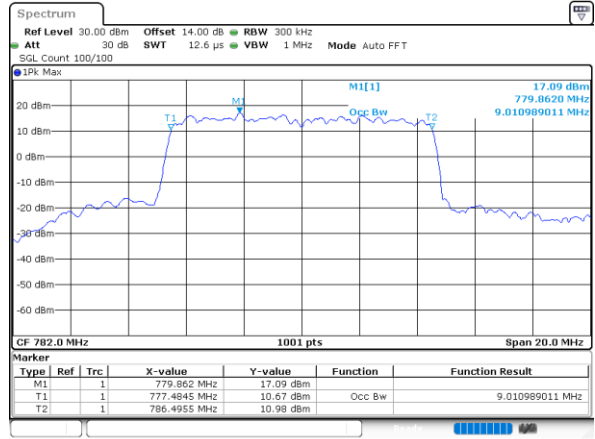

Date: 6.AUG.2024 01:55:15



Conducted Band Edge

LTE Band 13 / 5MHz / QPSK

Lowest Band Edge / 1 RB

Highest Band Edge / 1 RB

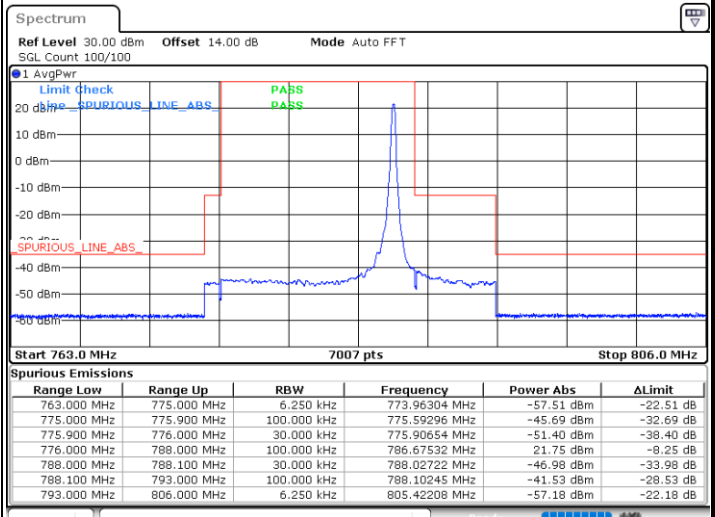
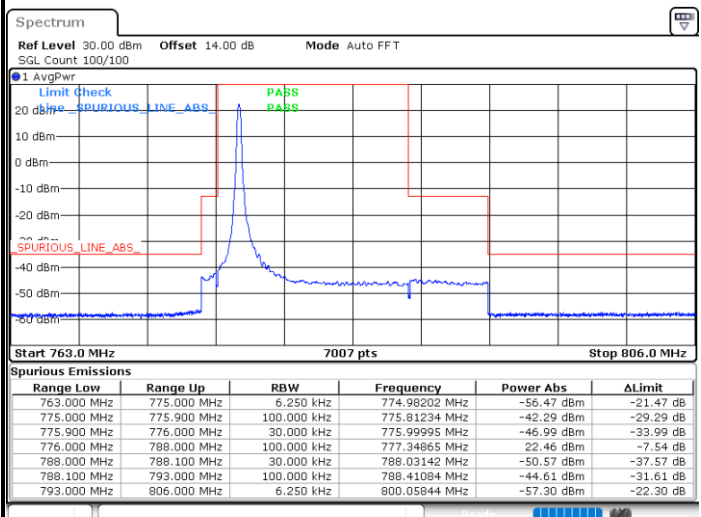

Date: 6.AUG.2024 01:28:36

Date: 6.AUG.2024 01:37:55

Lowest Band Edge / Full RB

Highest Band Edge / Full RB

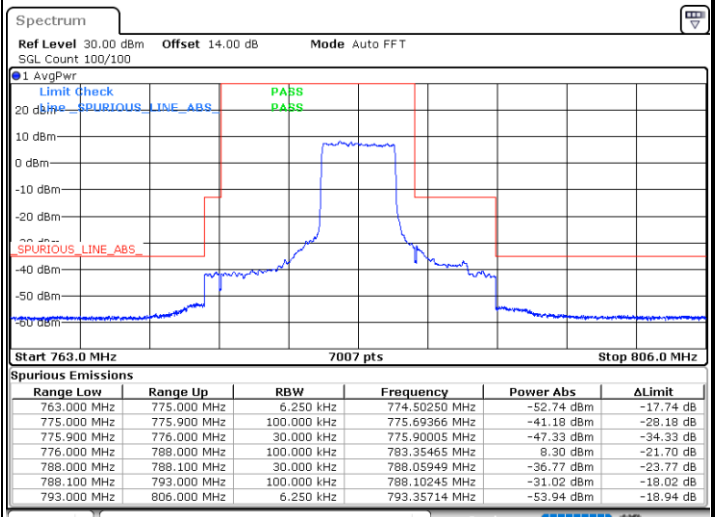
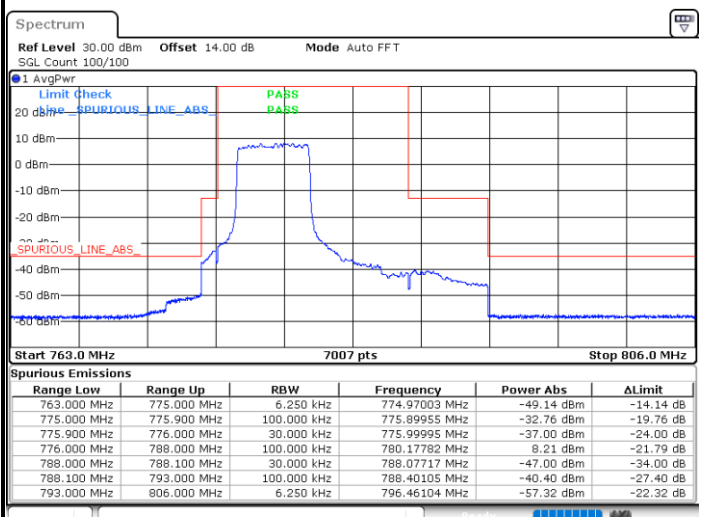

Date: 6.AUG.2024 01:31:25

Date: 6.AUG.2024 01:40:45



LTE Band 13 / 5MHz / 16QAM

Lowest Band Edge / 1 RB

Highest Band Edge / 1 RB

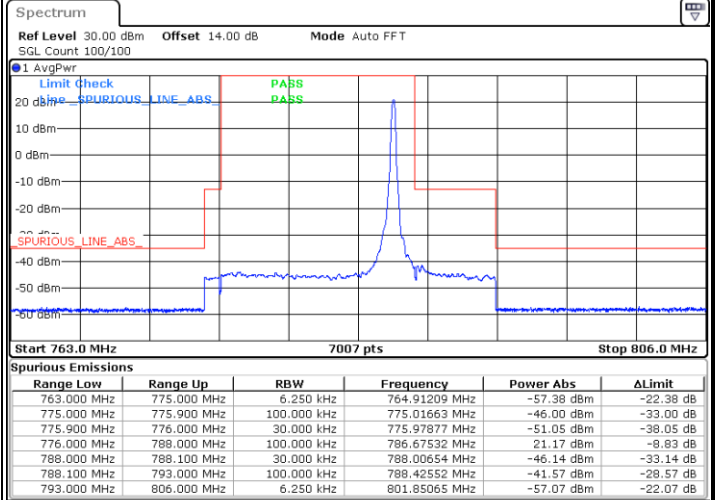
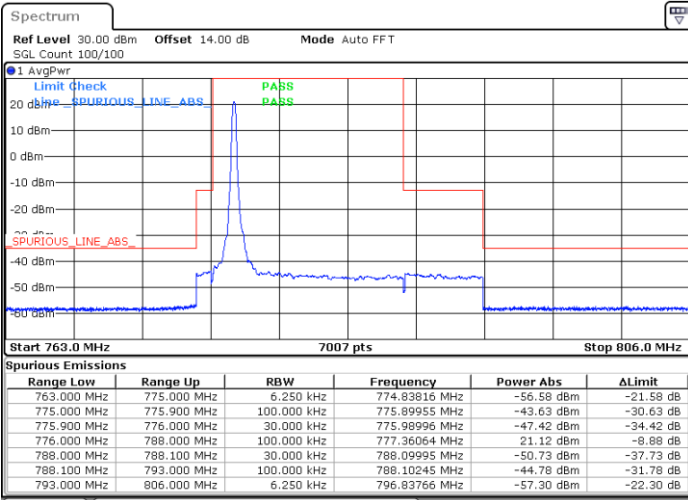

Date: 6.AUG.2024 01:29:32

Date: 6.AUG.2024 01:38:52

Lowest Band Edge / Full RB

Highest Band Edge / Full RB

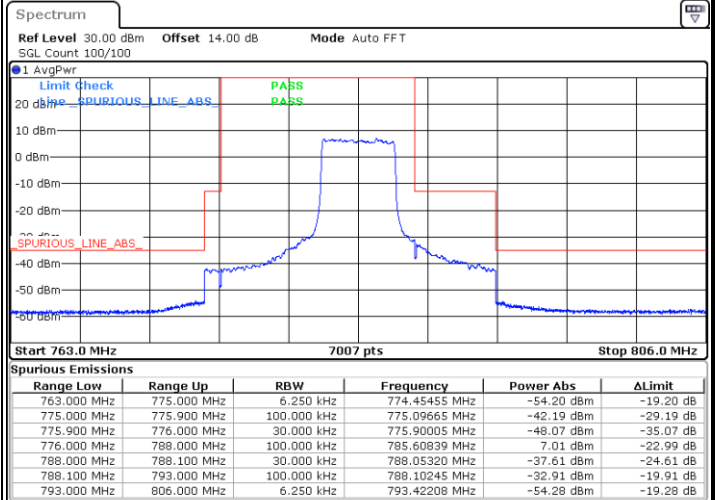
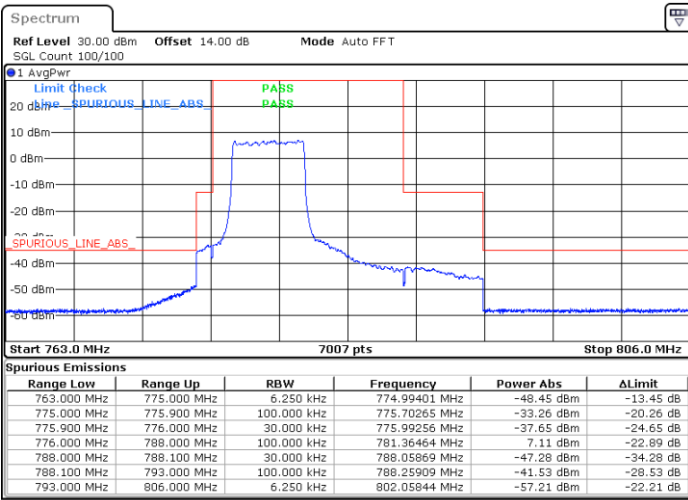

Date: 6.AUG.2024 01:32:22

Date: 6.AUG.2024 01:41:41