

HEARING AID COMPATIBILITY T-COIL TEST REPORT

FCC ID : 2ABZ2-EE103
Equipment : Smart Phone
Brand Name : ONEPLUS
Model Name : IN2015
T-Rating : T3
Applicant : OnePlus Technology (Shenzhen) Co., Ltd
18C02, 18C03, 18C04 and 18C05, Shum Yip Terra Building,
Binhe Avenue North, Futian District, Shenzhen
Manufacturer : OnePlus Technology (Shenzhen) Co., Ltd
18C02, 18C03, 18C04 and 18C05, Shum Yip Terra Building,
Binhe Avenue North, Futian District, Shenzhen
Standard : FCC 47 CFR §20.19
ANSI C63.19-2011

The product was received on Dec. 25, 2019 and testing was started from Dec. 28, 2019 and completed on Jan. 12, 2020. We, SPORTON INTERNATIONAL INC., would like to declare that the tested sample has been evaluated in accordance with the test procedures and has been in compliance with the applicable technical standards.

The report must not be used by the client to claim product certification, approval, or endorsement by TAF or any agency of government.

The test results in this report apply exclusively to the tested model / sample. Without written approval of SPORTON INTERNATIONAL INC. EMC & Wireless Communications Laboratory, the test report shall not be reproduced except in full.



Approved by: Cona Huang / Deputy Manager

SPORTON INTERNATIONAL INC. EMC & Wireless Communications Laboratory
No. 52, Huaya 1st Rd., Guishan Dist., Taoyuan City, Taiwan (R.O.C.)



Table of Contents

1. Attestation of Test Results4

2. General Information5

3. Testing Location.....6

4. Applied Standards6

5. Air Interface and Operating Mode.....7

6. Measurement standards for T-Coil8

6.1 Frequency Response8

6.2 T-Coil Signal Quality Categories.....8

7. T-Coil Test Procedure9

7.1 Test Flow Chart.....10

7.2 Test Setup Diagram for CMRS voice11

7.3 Test Setup and Diagram for OTT VoIP13

7.4 Description of EUT Test Position15

8. Test Equipment List16

9. T-Coil testing for CMRS Voice17

9.1 GSM Tests Results17

9.2 UMTS Tests Results18

9.3 CDMA Tests Results19

10. T-Coil testing for CMRS IP Voice20

10.1 VoLTE Tests Results20

10.2 VoWiFi Tests Results22

11. T-Coil testing for OTT VoIP Application24

12. Uncertainty Assessment28

13. References.....29

- Appendix A. Plots of T-Coil Measurement
- Appendix B. DASYS Calibration Certificate
- Appendix C. Test Setup Photos



History of this test report

Report No.	Version	Description	Issued Date
HA9N2021-03B	Rev. 01	Initial issue of report	Apr. 09, 2020



1. Attestation of Test Results

Air Interface	Band MHz	T-Rating	Frequency Response	Magnetic Intensity
GSM CMRS Voice	GSM850	T3	Pass	Pass
	GSM1900	T4	Pass	Pass
OTT over EDGE	EDGE850	T4	Pass	Pass
	EDGE1900	T4	Pass	Pass
UMTS CMRS Voice	Band 2	T4	Pass	Pass
	Band 4	T4	Pass	Pass
	Band 5	T4	Pass	Pass
OTT over UMTS	Band 2	T4	Pass	Pass
	Band 4	T4	Pass	Pass
	Band 5	T4	Pass	Pass
CDMA CMRS Voice	BC0	T4	Pass	Pass
	BC1	T4	Pass	Pass
	BC10	T4	Pass	Pass
OTT over CDMA	BC0	T4	Pass	Pass
	BC1	T4	Pass	Pass
	BC10	T4	Pass	Pass
VoLTE	Band 2	T4	Pass	Pass
	Band 4	T4	Pass	Pass
	Band 5	T4	Pass	Pass
	Band 7	T4	Pass	Pass
	Band 12	T4	Pass	Pass
	Band 13	T4	Pass	Pass
	Band 17	T4	Pass	Pass
	Band 25	T4	Pass	Pass
	Band 26	T4	Pass	Pass
	Band 30	T4	Pass	Pass
	Band 66	T4	Pass	Pass
	Band 71	T4	Pass	Pass
	Band 38	T4	Pass	Pass
	Band 48	T4	Pass	Pass
OTT over LTE	Band 41	T4	Pass	Pass
	Band 66	T4	Pass	Pass
OTT over 5G NR	n2	T4	Pass	Pass
	n5	T4	Pass	Pass
	n41	T4	Pass	Pass
	n66	T4	Pass	Pass
	n71	T4	Pass	Pass
VoWiFi	2450	T4	Pass	Pass
	5200	T4	Pass	Pass
	5300	T4	Pass	Pass
	5500	T4	Pass	Pass
	5800	T4	Pass	Pass
OTT over WiFi	2450	T4	Pass	Pass
	5800	T4	Pass	Pass
Date Tested	2019/12/28 ~ 2020/1/12			

The device is compliance with HAC limits specified in guidelines FCC 47CFR §20.19 and ANSI Standard ANSI C63.19.

Reviewed by: Jason Wang
Report Producer: Wan Liu



2. General Information

Product Feature & Specification	
Applicant Name	OnePlus Technology (Shenzhen) Co., Ltd
Equipment Name	Smart Phone
Brand Name	ONEPLUS
Model Name	IN2015
FCC ID	2ABZ2-EE103
EUT Stage	Production Unit
Frequency Band	GSM850: 824.2 MHz ~ 848.8 MHz GSM1900: 1850.2 MHz ~ 1909.8 MHz WCDMA Band II: 1852.4 MHz ~ 1907.6 MHz WCDMA Band IV: 1712.4 MHz ~ 1752.6 MHz WCDMA Band V: 826.4 MHz ~ 846.6 MHz CDMA2000 BC0: 824.7 MHz ~ 848.31 MHz CDMA 2000 BC1: 1851.25 MHz ~ 1908.75 MHz CDMA 2000 BC10: 817.9 MHz ~ 823.1 MHz LTE Band 2: 1850.7 MHz ~ 1909.3 MHz LTE Band 4: 1710.7 MHz ~ 1754.3 MHz LTE Band 5: 824.7 MHz ~ 848.3 MHz LTE Band 7: 2502.5 MHz ~ 2567.5 MHz LTE Band 12: 699.7 MHz ~ 715.3 MHz LTE Band 13: 779.5 MHz ~ 784.5 MHz LTE Band 17: 706.5 MHz ~ 713.5 MHz LTE Band 25: 1850.7 MHz ~ 1914.3 MHz LTE Band 26: 814.7 MHz ~ 848.3 MHz LTE Band 30: 2307.5 MHz ~ 2312.5 MHz LTE Band 38: 2572.5 MHz ~ 2617.5 MHz LTE Band 41: 2498.5 MHz ~ 2687.5 MHz LTE Band 48: 3552.5 MHz ~ 3697.5 MHz LTE Band 66: 1710.7 MHz ~ 1779.3 MHz LTE Band 71: 665.5 MHz ~ 695.5 MHz 5G NR n2 : 1852.5 MHz ~ 1907.5 MHz 5G NR n5 : 826.5 MHz ~ 846.5 MHz 5G NR n41 : 2506.02 MHz ~ 2679.99MHz 5G NR n66 : 1712.5 MHz ~ 1777.5 MHz 5G NR n71 : 665.5 MHz ~ 695.5 MHz WLAN 2.4GHz Band: 2412 MHz ~ 2462 MHz WLAN 5.2GHz Band: 5180 MHz ~ 5240 MHz WLAN 5.3GHz Band: 5260 MHz ~ 5320 MHz WLAN 5.5GHz Band: 5500 MHz ~ 5720 MHz WLAN 5.8GHz Band: 5745 MHz ~ 5825 MHz Bluetooth: 2402 MHz ~ 2480 MHz NFC: 13.56 MHz
Mode	GSM/GPRS/EGPRS AMR / RMC 12.2Kbps HSDPA HSUPA DC-HSDPA HSPA+ (16QAM uplink) CDMA2000 : 1xRTT/1xEv-Do(Rel.0)/1xEv-Do(Rev.A) LTE: QPSK, 16QAM, 64QAM 5G NR : CP-OFDM / DFT-s-OFDM · PI/2 BPSK , QPSK, 16QAM, 64QAM WLAN 2.4GHz : 802.11b/g/n/ax HT20/HE20/HE40 WLAN 5GHz : 802.11a/n/ac/ax HT20/HT40/VHT20/VHT40/VHT80/HE20/HE40/HE80 Bluetooth BR/EDR/LE NFC:ASK
Remark:	1. Changed model name, all the test case which can be referred to Sporton SAR Test Report, Report No: HA9N2021-02B. 2. This device has WWAN UAT and LAT transmitter antennas which can refer to antenna location chapter. 3. The 2.4GHz/5GHz WLAN can transmit in MIMO antenna mode only and it has no SISO antenna mode.



3. Testing Location

Sporton Lab is accredited to ISO 17025 by Taiwan Accreditation Foundation (TAF code: 1190) and the FCC designation No. TW1190 under the FCC 2.948(e) by Mutual Recognition Agreement (MRA) in FCC test.

Testing Laboratory	
Test Site	SPORTON INTERNATIONAL INC.
Test Site Location	No. 52, Huaya 1st Rd., Guishan Dist., Taoyuan City, Taiwan (R.O.C.) TEL: +886-3-327-3456 FAX: +886-3-328-4978
Test Site No.	Sporton Site No.: SAR04-HY

4. Applied Standards

- FCC CFR47 Part 20.19
- ANSI C63.19 2011-version
- FCC KDB 285076 D01 HAC Guidance v05
- FCC KDB 285076 D02 T Coil testing v03
- FCC KDB 285076 D03 HAC FAQ v01



5. Air Interface and Operating Mode

Air Interface	Band MHz	Type	C63.19 Tested	Simultaneous Transmitter	Name of Voice Service	Power Reduction
GSM	GSM850	VO	Yes	WLAN, BT	CMRS Voice	No
	GSM1900			WLAN, BT		No
	EDGE850	VD	Yes	WLAN, BT	Android dialing ^(1,2) / Google Duo ⁽¹⁾	No
	EDGE1900					
UMTS	850	VO	Yes	WLAN, BT	CMRS Voice	No
	1750			WLAN, BT		No
	1900			WLAN, BT		No
	HSPA	VD	Yes	WLAN, BT	Android dialing ^(1,2) / Google Duo ⁽¹⁾	No
CDMA	850	VO	Yes	WLAN, BT	CMRS Voice	No
	1900			WLAN, BT		No
	EVDO	VD	Yes	WLAN, BT	Android dialing ^(1,2) / Google Duo ⁽¹⁾	No
LTE (FDD)	Band 2	VD	Yes	WLAN, BT	VoLTE / Android dialing ^(1,2) / Google Duo ⁽¹⁾	No
	Band 4			No		
	Band 5			No		
	Band 7			No		
	Band 12			No		
	Band 13			No		
	Band 17			No		
	Band 25			No		
	Band 26			No		
	Band 30			No		
	Band 66			No		
	Band 71			No		
LTE (TDD)	Band 38	VD	Yes	WLAN, BT	VoLTE / Android dialing ^(1,2) / Google Duo ⁽¹⁾	No
	Band 41			WLAN, BT		No
	Band 48			WLAN, BT		No
5G NR (FDD)	n2	VD	Yes	WLAN, BT	Android dialing ^(1,2) / Google Duo ⁽¹⁾	No
	n5			WLAN, BT		No
	n66			WLAN, BT		No
	n71			WLAN, BT		No
5G NR (TDD)	n41	VD	Yes	WLAN, BT	Android dialing ^(1,2) / Google Duo ⁽¹⁾	No
Wi-Fi	2450	VD	Yes	GSM,CDMA,WCDMA,LTE or NR	VoWiFi ⁽¹⁾ / Android dialing ^(1,2) / Google Duo ⁽¹⁾	No
	5200					No
	5300					No
	5500					No
	5800					No
BT	2450	DT	No	GSM,CDMA,WCDMA,LTE or NR	NA	No

Type Transport:
 VO= Voice only
 DT= Digital Transport only (no voice)
 VD= CMRS and IP Voice Service over Digital Transport

Remark:

- For protocols not listed in Table 7.1 of ANSI C63.19-2011 or the ANSI C63.19-2011 VoLTE interpretation, the average speech level of -20 dBm0 should be used.
- Android SIP calling is an pre-installed feature but does not itself represent a service, to use SIP calling the user has to enter the account/password and the information of the server which actually provides the service. In this report it is demonstrated that both Android SIP calling and Duo are both compliant to FCC HAC technical requirement
- The device have similar frequency in some LTE bands: LTE B12/17, 5/26, 4/66, 2/25, 38/41, since the supported frequency spans for the smaller LTE bands are completely cover by the larger LTE bands, therefore, only larger LTE bands were required to be tested for hearing-aid compliance.

6. Measurement standards for T-Coil

6.1 Frequency Response

The frequency response of the perpendicular component of the magnetic field, measured in 1/3 octave bands, shall follow the response curve specified in this sub-clause, over the frequency range 300 Hz to 3000 Hz.

Figure 1.1 and Figure 1.2 provide the boundaries as a function of frequency. These response curves are for true field-strength measurements of the T-Coil signal. Thus, the 6 dB/octave probe response has been corrected from the raw readings.

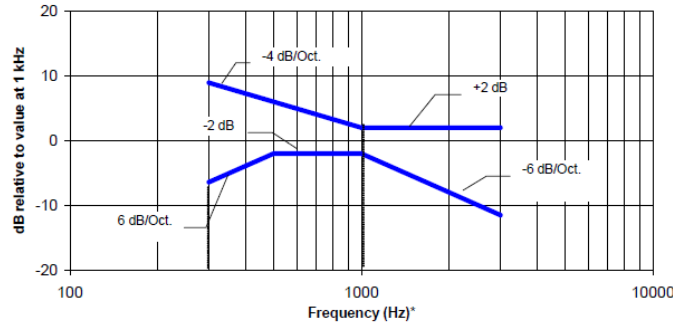

NOTE—The frequency response is between 300 Hz and 3000 Hz.

Fig. 1.1 Magnetic field frequency response for WDs with field strength ≤ -15 dB at 1 kHz

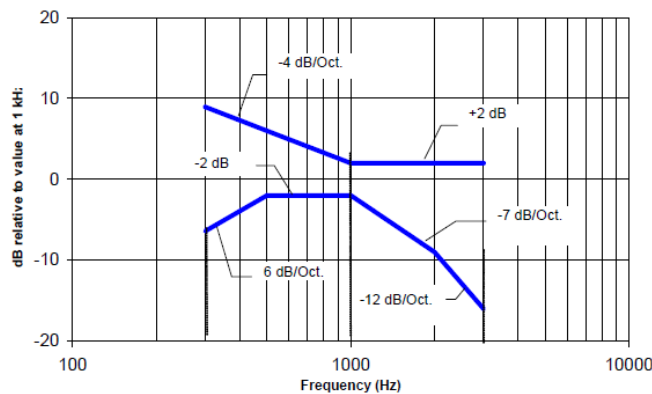

NOTE—The frequency response is between 300 Hz and 3000 Hz.

Fig. 1.2 Magnetic field frequency response for WDs with a field that exceeds -15 dB(A/m) at 1 kHz

6.2 T-Coil Signal Quality Categories

This section provides the signal quality requirement for the intended T-Coil signal from a WD. Only the RF immunity of the hearing aid is measured in T-Coil mode. It is assumed that a hearing aid can have no immunity to an interference signal in the audio band, which is the intended reception band for this mode. A device is assessed beginning by determining the category of the RF environment in the area of the T-Coil source.

The RF measurements made for the T-Coil evaluation are used to assign the category T1 through T4. The limitation is given in Table 1. This establishes the RF environment presented by the WD to a hearing aid.

Category	Telephone parameters WD signal quality ((signal + noise) to noise ratio in dB)
Category T1	0 to 10 dB
Category T2	10 to 20 dB
Category T3	20 to 30 dB
Category T4	> 30 dB

Table 1 T-Coil Signal Quality Categories



7. T-Coil Test Procedure

Referenced to ANSI C63.19-2011, Section 7.4,

This section describes the procedures used to measure the ABM (T-Coil) performance of the WD. In addition to measuring the absolute signal levels, the A-weighted magnitude of the unintended signal shall also be determined. To assure that the required signal quality is measured, the measurement of the intended signal and the measurement of the unintended signal must be made at the same location for each measurement position. In addition, the RF field strength at each measurement location must be at or below that required for the assigned category.

Measurements shall not include undesired properties from the WD's RF field; therefore, use of a coaxial connection to a base station simulator or non-radiating load, there might still be RF leakage from the WD, which can interfere with the desired measurement. Pre-measurement checks should be made to avoid this possibility. All measurements shall be performed with the WD operating on battery power with an appropriate normal speech audio signal input level given in ANSI C63.19-2011 Table 7.1. If the device display can be turned off during a phone call, then that may be done during the measurement as well,

Measurement shall be performed at two locations specified in ANSI C63.19-2011 A.3, with the correct probe orientation for a particular location, in a multistage sequence by first measuring the field intensity of the desired T-Coil signal the same location as the desired ABM or T-Coil signal (ABM1), and the ratio of desired to undesired magnetic components (ABM2) must be measured at the same location as the desired ABM or T-Coil signal (ABM1), and the ratio of desired to undesired ABM signals must be calculated. For the perpendicular field location, only the ABM1 frequency response shall be determined in a third measurement stage.

The following steps summarize the basic test flow for determining ABM1 and ABM2. These steps assume that a sine wave or narrowband 1/3 octave signal can be used for the measurement of ABM1.

- a. A validation of the test setup and instrumentation may be performed using a TMFS or Helmholtz coil Measure the emissions and confirm that they are within the specified tolerance.
- b. Position the WD in the test setup and connect the WD RF connector to a base station simulator or a non-radiating load. Confirm that equipment that requires calibration has been calibrated, and that the noise level meets the requirements given in ANSI C63.19-2011 clause 7.3.1.
- c. The drive level to the WD is set such that the reference input level specified in ANSI C63.19-2011 Table 7.1 is input to the base station simulator (or manufacturer's test mode equivalent) in 1 kHz, 1/3 octave band. This drive level shall be used for the T-Coil signal test (ABM1) at $f = 1$ kHz. Either a sine wave at 1025 Hz or a voice-like signal, band-limited to the 1 kHz 1/3 octave, as defined in ANSI C63.19-2011 clause 7.4.2, shall be used for the reference audio signal. If interference is found at 1025 Hz an alternative nearby reference audio signal frequency may be used. The same drive level shall be used for the ABM1 frequency response measurements at each 1/3 octave band center frequency. The WD volume control may be set at any level up to maximum, provided that a signal at any frequency at maximum modulation would not result in clipping or signal overload.
- d. Determine the magnetic measurement locations for the WD device (A.3), if not already specified by the manufacturer, as described in ANSI C63.19-2011 clause 7.4.4.1.1 and 7.4.4.2.
- e. At each measurement location, measure and record the desired T-Coil magnetic signals (ABM1 at f_i) as described in ANSI C63.19-2011 clause 7.4.4.2 in each individual ISO 266-1975 R10 standard 1/3 octave band. The desired audio band input frequency (f_i) shall be centered in each 1/3 octave band maintaining the same drive level as determined in item c) and the reading taken for that band.
- f. Equivalent methods of determining the frequency response may also be employed, such as fast Fourier transform (FFT) analysis using noise excitation or input-output comparison using simulated speech. The full-band integrated probe output, as specified in D.9, may be used, as long as the appropriate calibration curve is applied to the measured result, so as to yield an accurate measurement of the field magnitude. (The resulting measurement shall be an accurate measurement in dB A/m.)
- g. All Measurements of the desired signal shall be shown to be of the desired signal and not of an undesired signal. This may be shown by turning the desired signal ON and OFF with the probe measuring the same location. If the scanning method is used the scans shall show that all measurement points selected for the ABM1 measurement meet the ambient and test system noise criteria in ANSI C63.19-2011 clause 7.3.1.
- h. At the measurement location for each orientation, measure and record the undesired broadband audio magnetic signal (ABM2) as specified in ANSI C63.19-2011 clause 7.4.4.4 with no audio signal applied (or digital zero applied, if appropriate) using A-weighting and the half-band integrator. Calculate the ratio of the desired to undesired signal strength (i.e., signal quality).
- i. Obtain the data from the postprocessor, SEMCAD, and determine the category that properly classifies the signal quality based on ANSI C63.19-2011 Table 8.5.

7.1 Test Flow Chart

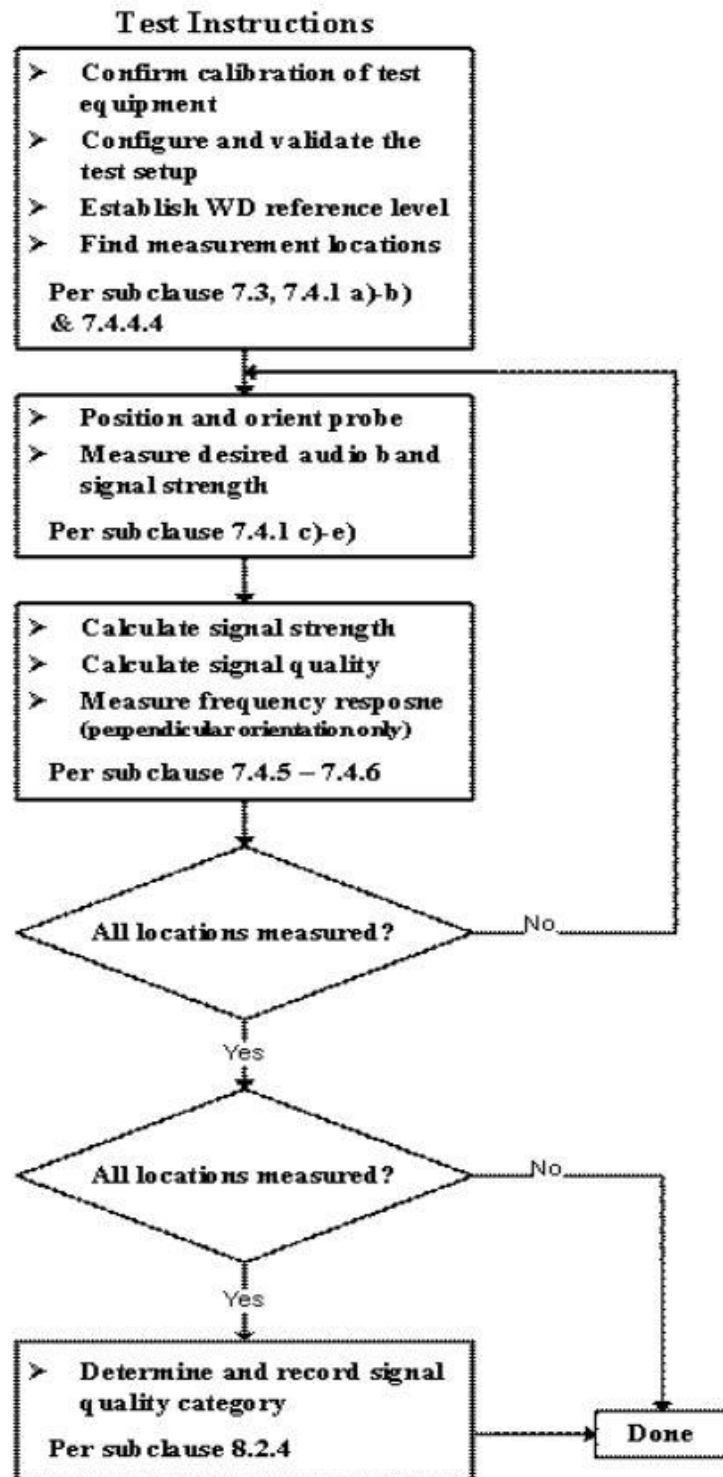
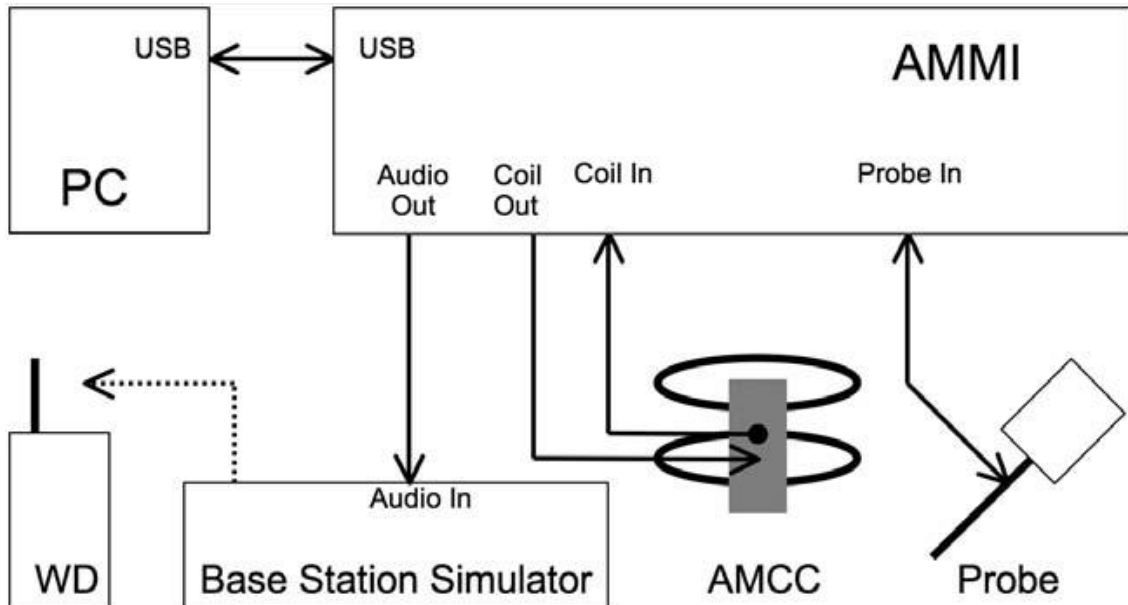

Fig. 2 T-Coil Signal Test flowchart

7.2 Test Setup Diagram for CMRS voice



General Note:

1. Define the all applicable input audio level as below according to C63 and KDB 285076 D02v03:
 - GSM input level: -16dBm0
 - UMTS input level: -16dBm0
 - CDMA input level: -18dBm0
 - VoLTE input level: -16dBm0
 - VoWiFi input level: -20dBm0
2. For GSM / UMTS / CDMA test setup and input level, the correct input level definition is via a communication tester CMU200's "Decoder Cal" and "Codec Cal" with audio option B52 and B85 to set the correct audio input levels.
3. CMU200 is able to output 1kHz audio signal equivalent to 3.14dBm0 at "Decoder Cal." configuration, the signal reference is used to adjust the AMMI gain setting to reach -16dBm0 for GSM/UMTS and -18dBm0 for CDMA. CMW500 input is calibrated and the relation between the analog input voltage and the internal level in dBm0 can be determined
4. The test setup used for VoLTE over IMS and VoWiFi over IMS is via the callbox of CMW500 for T-coil measurement, The data application unit of the CMW500 was used to simulate the IP multimedia subsystem server. The CMW500 can be manually configured to ensure and control the speech input level result is -16dBm0 for VoLTE, -20dBm0 for VoWiFi when the device during the IMS connection.



1. The Required gain factor for the specific signal shall typically be multiplied by this factor to achieve approx. the same level as for the 1kHz sine signal
2. The below calculation formula is an example and showing how to determine the input level for the device.

The predefined signal types have the following differences / factors compared to the 1kHz sine signal:

Signal [file name]	Duration [s]	Peak-to-RMS [dB]	RMS [dB]	Required gain factor (*)	Gain setting
1kHz sine	---	3.0	0.0	1.00	
48k_1.025kHz_10s.wav	10	3.0	0.0	1.00	
48k_1kHz_3.15kHz_10s.wav	10	6.0	-3.0	1.42	
48k_315Hz_1kHz_10s.wav	10	6.0	-2.9	1.40	
48k_csek_8k_441_white_10s.wav	10	13.8	-10.5	3.34	
48k_multisine_50-5000_10s.wav	10	11.1	-7.9	2.49	
48k_voice_1kHz_1s.wav	1	16.2	-12.7	4.33	
48k_voice_300-3000_2s.wav	2	21.6	-18.6	8.48	

(*) The gain for the specific signal shall typically be multiplied by this factor to achieve approx. the same level as for the 1kHz sine signal.

Insert the gain applicable for your setup in the last column of the table.

Calculation formula:

- Audio Level at -16dBm0 = ((-16dBm0) – (3.14dBm0)) + X dBv
- Calculated Gain at -16dBm0 = 10((audio level at -16dBm0 – Y dBm0) / 20) * 10
- Gattting setting at -16dBm0 = required gain factor * calculated gain

Gain Value	20* log(gain)	AMCC Coil In	Level
(linear)	dB	(dBv RMS)	dBm0
		-2.47	3.14
10	20	-19.85	-14.24
8.20	18.27	-18.48	-16

Signal Type	Duration (s)	Peak to RMS (dB)	RMS (dB)	Required Gain Factor	Calculated Gain Setting
1kHz sine	-	3	0	1	8.20
48k_voice_1kHz	1	16.2	-12.7	4.33	35.49
48k_voice_300Hz ~ 3kHz	2	21.6	-18.6	8.48	69.50

7.3 Test Setup and Diagram for OTT VoIP

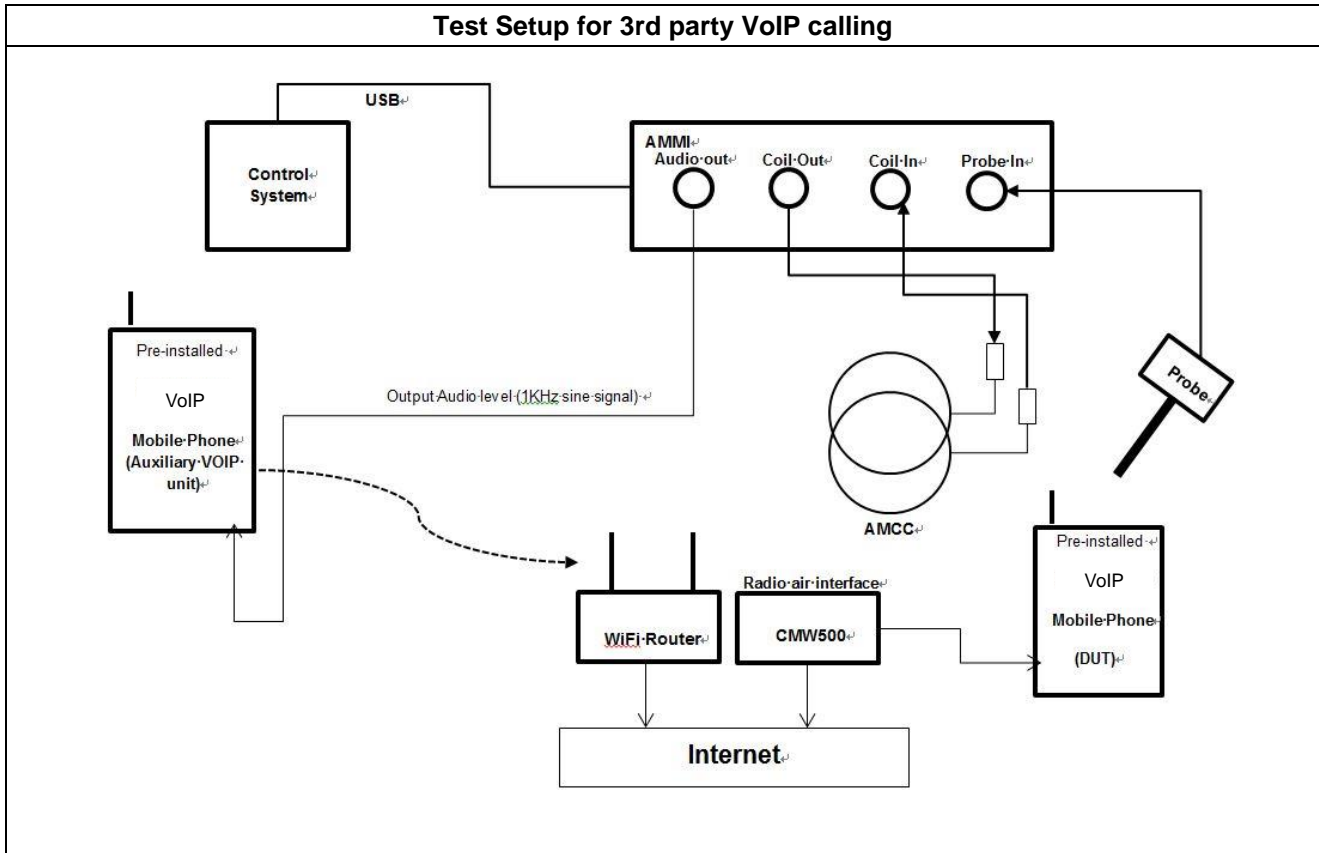

General Note:

1. Define the all applicable input audio level as below according to C63 and KDB 285076 D02v03:
- OTT VoIP input Level: -20dBm0
2. Voice over Internet Protocol (VoIP) such as google duo application, also called IP telephony, is a methodology and group of technologies for the delivery of voice communications and multimedia sessions over Internet Protocol (IP) networks, such as the Internet. The terms Internet telephony, broadband telephony, and broadband phone service specifically refer to the provisioning of communications services (voice, fax, SMS, voice-messaging) over the public Internet, rather than via the public switched telephone network (PSTN)
3. The Google DUO / android dialing service support code and bitrate are list in section11, the customized Google DUO / android dialing software is installed on a mobile phone which is used as the Auxiliary for the test. The software enables audio coding rate to be changed, and reports the input digital audio level before audio processing which can be used to calibrate the input audio level.
4. This device comes with the preinstalled VoIP application that supports the Google DUO / android dialing service and related codec. The test configuration establishes a call between the device under test and an auxiliary handset via the google DUO / android dialing server
5. The test setup used for Google DUO / android dialing VoIP call is via the data application unit on the CMW, connected to the internet via the google DUO / android dialing server to the auxiliary device. The auxiliary device runs special software that allows the codecs and bit rate to be fixed to a specific value. Please refer to section11, an assessment was made of each of the different codec bit rates to determine the worst case for each of the different OTT transport (WiFi, LTE FDD, LTE TDD, GSM, WCDMA)
6. The auxiliary device includes software that displays the audio level in dBFS which allows calibration of the system to establish the -20dBm0 reference level. After establishing the voice call between auxiliary device and device under test the audio output from the AMMI is injected into the auxiliary device. The gain factor to establish a reference level of -20dBm0 for use during the test is determined as detailed in the next page based on the 0dBFull Scale (0dBFS) value being equivalent to 3.14dBm0.

<Define the input level for OTT VoIP>

1. The Required gain factor for the specific signal shall typically be multiplied by this factor to achieve approx. the same level as for the 1kHz sine signal
2. The below calculation formula is an example and showing how to determine the input level for the device.
3. Input a gain value to readout the -23dBFS level as reference. (0dBFS = 3.14 dBm0)
4. Adjust gain level until to readout the dBFS level until it changes to -24dBFS.
5. Based on the step 1 and 2, and then calculate the gain value(dB) by interpolation to get the -20dBm0 corresponding gain value.

The predefined signal types have the following differences / factors compared to the 1kHz sine signal:

Signal [file name]	Duration [s]	Peak-to-RMS [dB]	RMS [dB]	Required gain factor *)	Gain setting
1kHz sine	---	3.0	0.0	1.00	
48k_1.025kHz_10s.wav	10	3.0	0.0	1.00	
48k_1kHz_3.15kHz_10s.wav	10	6.0	-3.0	1.42	
48k_315Hz_1kHz_10s.wav	10	6.0	-2.9	1.40	
48k_csek_8k_441_white_10s.wav	10	13.8	-10.5	3.34	
48k_multisine_50-5000_10s.wav	10	11.1	-7.9	2.49	
48k_voice_1kHz_1s.wav	1	16.2	-12.7	4.33	
48k_voice_300-3000_2s.wav	2	21.6	-18.6	8.48	

(*) The gain for the specific signal shall typically be multiplied by this factor to achieve approx. the same level as for the 1kHz sine signal.

Insert the gain applicable for your setup in the last column of the table.

Step	Signal type	Audio out		Target Level	
		Gain value	Gain value (dB)	dBFS	dBm0
Step 1	1KHz Sine	7.7	17.73 (Ref.)	-23	
Step 2	1KHz Sine	6.8	16.65	-24	
Step 3	1KHz Sine	7.57**	17.58*	-23.14	-20
Remark	(*) Based on the step 1 and 2 and then via interpolation to get this value. (**) Gain value=10 ^{Gain value(dB)/20}				
Signal type	Duration (s)	Peak to RMS (dB)	RMS (dB)	Gain Factor	Gain value
1kHz sine		3	0	1	7.57
48k_voice_1kHz_1s.wav	1	16.2	-12.7	4.33	32.77
48k_voice_300-3000_2s.wav	2	21.6	-18.6	8.48	64.79
<ol style="list-style-type: none"> 1. According to the gain setting for 1kHz sine wave, determine the gain setting for signals above. 2. The gain for the specific signal is multiplied by this factor to achieve the same level as for the 1kHz sine signal. 					

7.4 Description of EUT Test Position

Fig.3 illustrate the references and reference plane that shall be used in a typical EUT emissions measurement. The principle of this section is applied to EUT with similar geometry. Please refer to Appendix C for the setup photographs.

- ◆ The area is 5 cm by 5 cm.
- ◆ The area is centered on the audio frequency output transducer of the EUT.
- ◆ The area is in a reference plane, which is defined as the planar area that contains the highest point in the area of the phone that normally rests against the user’s ear. It is parallel to the centerline of the receiver area of the phone and is defined by the points of the receiver-end of the EUT handset, which, in normal handset use, rest against the ear.
- ◆ The measurement plane is parallel to, and 10 mm in front of, the reference plane.

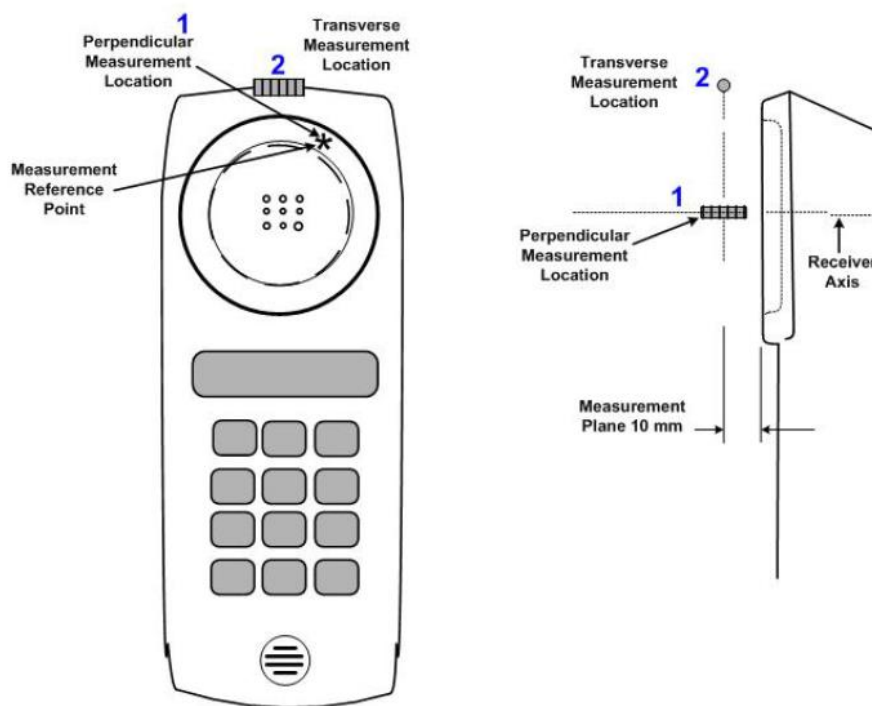

Fig.3 A typical EUT reference and plane for T-Coil measurements



8. Test Equipment List

Manufacturer	Name of Equipment	Type/Model	Serial Number	Calibration	
				Last Cal.	Due Date
SPEAG	Audio Magnetic 1D Field Probe	AM1DV3	3130	Nov. 20, 2019	Nov. 19, 2020
SPEAG	Data Acquisition Electronics	DAE4	854	May. 21, 2019	May. 20, 2020
SPEAG	Audio Magnetic Calibration Coil	AMCC	1049	NCR	NCR
SPEAG	Audio Measuring Instrument	AMMI	1041	NCR	NCR
SPEAG	Test Arch Phantom	N/A	N/A	NCR	NCR
SPEAG	Phone Positioner	N/A	N/A	NCR	NCR
Testo	Hygro meter	608-H1	45207528	Nov. 18, 2019	Nov. 17, 2020
R&S	Base Station	CMW500	115793	Jun. 04, 2019	Jun. 03, 2020
R&S	Base Station	CMU200	117591	Dec. 09, 2019	Dec. 08, 2020

Note:

- 1. NCR: "No-Calibration Required"



9. T-Coil testing for CMRS Voice

General Note:

1. **Codec Investigation:** For a voice service/air interface, investigate the variations of codec configurations (WB, NB bit rate) and document the parameters (ABM1, ABM2, S+N/N, frequency response) for that voice service. It is only necessary to document this for one channel/band, the following worst investigation codec would be remarked to be used for the testing for the handset.
2. **Air Interface Investigation:**
 - a. Use the worst-case codec test and document a limited set of bands/channel/bandwidths. Observe the effect of changing the band and bandwidth to ensure that there are no unexpected variations. Using the knowledge of the observed variations, it is necessary to report only a set band/channel/bandwidth for each orientation for a voice service/air interface.
 - b. According to the ANSI C63.19 2011 section 7.3.2, test middle channel of each frequency band for HAC testing for each orientation to determine worst HAC T-Coil rating.

9.1 GSM Tests Results

<Codec Investigation>

GSM Codec				
Codec	FR_V1	HR_V1	Orientation	Band / Channel
ABM 1 (dBA/m)	7.95	9.07	Axial	GSM850 / 189
ABM 2 (dBA/m)	-22.25	-24.97		
Signal Quality (dB)	30.2	34.04		
Freq. Response	PASS	PASS		

Remark: According to codec investigation, the worst codec is FR_V1

<Air Interface Investigation>

Plot No.	Air Interface	Mode	Channel	Probe Position	ABM1 dB (A/m)	ABM2 dB (A/m)	Signal Quality dB	T Rating	Ambient Noise dB (A/m)	Freq. Response Variation dB	Frequency Response
1	GSM850	Voice	189	Axial (Z)	7.95	-21.26	29.21	T3	-50.33	1.77	Pass
				Transversal (Y)	-1.12	-30.68	29.56	T3	-50.21		
2	GSM1900	Voice	661	Axial (Z)	8.10	-27.24	35.34	T4	-50.34	2	Pass
				Transversal (Y)	0.62	-36.37	36.99	T4	-50.25		



9.2 UMTS Tests Results

<Codec Investigation>

Codec	AMR 4.75Kbps	AMR 7.95Kbps	AMR 12.2Kbps	Orientation	Band / Channel
ABM 1 (dBA/m)	8.69	8.69	11.91	Axial	Band 5 / 4182
ABM 2 (dBA/m)	-36.24	-34.2	-30.15		
Signal Quality (dB)	44.93	42.89	42.06		
Freq. Response	PASS	PASS	PASS		

Remark: According to codec investigation, the worst codec is AMR 12.2Kbps

<Air Interface Investigation>

Plot No.	Air Interface	Mode	Channel	Probe Position	ABM1 dB (A/m)	ABM2 dB (A/m)	Signal Quality dB	T Rating	Ambient Noise dB (A/m)	Freq. Response Variation dB	Frequency Response
3	WCDMA II	Voice	9400	Axial (Z)	7.67	-34.26	41.93	7.67	-34.26	2	Pass
				Transversal (Y)	3.50	-37.80	41.30	3.50	-37.80		
4	WCDMA IV	Voice	1413	Axial (Z)	11.77	-30.06	41.83	11.77	-30.06	2	Pass
				Transversal (Y)	3.80	-37.88	41.68	3.80	-37.88		
5	WCDMA V	Voice	4182	Axial (Z)	11.91	-30.15	42.06	11.91	-30.15	2	Pass
				Transversal (Y)	2.84	-38.53	41.37	2.84	-38.53		



9.3 CDMA Tests Results

<Codec Investigation>

CDMA Codec					
Codec	RC1 SO68	RC3 SO68	RC4 SO68	Orientation	Band / Channel
ABM 1 (dBA/m)	5.35	5.97	6.55	Axial	BC0 / 384
ABM 2 (dBA/m)	-39.89	-39.61	-38.31		
Signal Quality (dB)	45.24	45.58	44.86		
Freq. Response	PASS	PASS	PASS		

Remark: According to codec investigation, the worst codec is RC4 SO68.

<Air Interface Investigation>

Plot No.	Air Interface	Mode	Channel	Probe Position	ABM1 dB (A/m)	ABM2 dB (A/m)	Signal Quality dB	T Rating	Ambient Noise dB (A/m)	Freq. Response Variation dB	Frequency Response
6	CDMA BC0	RC3+SO68 Voice codec8K Enhanced low	384	Axial (Z)	6.55	-38.31	44.86	T4	-50.35	2	Pass
				Transversal (Y)	-2.75	-44.17	41.42	T4	-50.22		
7	CDMA BC1	RC3+SO68 Voice codec8K Enhanced low	600	Axial (Z)	6.35	-35.98	42.33	T4	-50.37	2	Pass
				Transversal (Y)	-4.94	-46.70	41.76	T4	-50.26		
8	CDMA BC10	RC3+SO68 Voice codec8K Enhanced low	580	Axial (Z)	4.38	-40.33	44.71	T4	-5.30	1.93	Pass
				Transversal (Y)	-1.57	-43.44	41.87	T4	-50.24		



10. T-Coil testing for CMRS IP Voice

10.1 VoLTE Tests Results

General Note:

1. Codec Investigation: For a voice service/air interface, investigate the variations of codec configurations (WB, NB bit rate) and document the parameters (ABM1, ABM2, S+N/N, frequency response) for that voice service. It is only necessary to document this for one channel / band, the following worst investigation codec would be remarked to be used for the testing for the handset.
2. Air Interface Investigation:
 - a. Use the worst-case codec test and document a limited set of bands / channel / bandwidths. Observe the effect of changing the band and bandwidth to ensure that there are no unexpected variations. Using the knowledge of the observed variations, it is necessary to report only a set band/channel/bandwidth for each orientation for a voice service/air interface and the following worst configuration would be remarked to be used for the testing for the handset.
 - b. Select LTE FDD / TDD one frequency band to do measurement at the worst SNR position was additionally performed with varying the BWs/Modulations/RB size to verify the variation to find out worst configuration , the observed variation is very little to be within 1.5 dB which is much less than the margin from the rating threshold.
 - c. The TDD LTE power class 3 supports uplink-downlink configuration 0 and 6 and power class 2 supports uplink-downlink configuration1 to 5 for this device, an investigation was performed to determine the worst-case uplink-downlink configuration to be used for the testing for the handset.
 - d. According to the ANSI C63.19 2011 section 7.3.2, test middle channel of each frequency band for HAC testing for each orientation to determine worst HAC T-Coil rating.

<Codec Investigation>

LTE FDD

Codec	NB AMR 4.75Kbps	WB AMR 6.60Kbps	NB AMR 12.2Kbps	WB AMR 23.85Kbps	EVS SWB 9.6Kbps	EVS SWB 128Kbps	EVS WB 5.9Kbps	EVS WB 128Kbps	EVS NB 5.9Kbps	EVS NB 24.4Kbps	Orientation	Band / BW / Channel
ABM 1 (dBA/m)	7.76	5.9	8.1	7.03	9.79	6.9	7.61	6.86	6.47	7.5	Axial	B25 / 20M / 26340
ABM 2 (dBA/m)	-33.65	-32.9	-32.57	-32.65	-30.08	-33.02	-32.34	-32.99	-33.43	-32.42		
Signal Quality (dB)	41.41	38.8	40.67	39.68	39.87	39.92	39.95	39.85	39.9	39.92		
Freq. Response	Pass	Pass	Pass	Pass	Pass	Pass	Pass	Pass	Pass	Pass		

Remark: According to codec investigation, the worst codec is WB AMR 6.60Kbps

LTE TDD

Codec	NB AMR 4.75Kbps	WB AMR 6.60Kbps	NB AMR 12.2Kbps	WB AMR 23.85Kbps	EVS SWB 9.6Kbps	EVS SWB 128Kbps	EVS WB 5.9Kbps	EVS WB 128Kbps	EVS NB 5.9Kbps	EVS NB 24.4Kbps	Orientation	Band / BW / Channel
ABM 1 (dBA/m)	6.97	5.83	8.4	8.45	8.07	7.31	7.46	6.15	6.19	8.42	Axial	B41 / 20M / 40620
ABM 2 (dBA/m)	-33.75	-32.96	-32.21	-31.19	-31.98	-32.63	-32.61	-33.81	-33.83	-31.25		
Signal Quality (dB)	40.72	38.79	40.61	39.64	40.05	39.94	40.07	39.96	40.02	39.67		
Freq. Response	Pass	Pass	Pass	Pass	Pass	Pass	Pass	Pass	Pass	Pass		

Remark: According to codec investigation, the worst codec is WB AMR 6.60Kbps



<Air Interface Investigation>

Air Interface		BW (MHz)	Modulation	RB Size	RB offset	Channel	UL-DL Configuration	ABM1 dB (A/m)	ABM2 dB (A/m)	Signal Quality dB
FDD	LTE B25	20	QPSK	1	0	26340	-	5.73	-32.62	38.35
	LTE B25	20	QPSK	50	0	26340	-	6.21	-32.77	38.98
	LTE B25	20	QPSK	100	0	26340	-	5.99	-32.78	38.77
	LTE B25	20	16QAM	1	0	26340	-	5.81	-32.76	38.57
	LTE B25	20	64QAM	1	0	26340	-	6.02	-32.67	38.69
	LTE B25	15	QPSK	1	0	26340	-	6.19	-32.70	38.89
	LTE B25	10	QPSK	1	0	26340	-	6.11	-32.78	38.89
	LTE B25	5	QPSK	1	0	26340	-	5.93	-32.72	38.65
	LTE B25	3	QPSK	1	0	26340	-	6.43	-32.81	39.24
	LTE B25	1.4	QPSK	1	0	26340	-	6.19	-32.89	39.08
TDD	LTE B41_PC3	20	QPSK	1	0	40620	0	5.82	-31.93	37.75
	LTE B41_PC3	20	QPSK	1	0	40620	1	6.27	-31.82	38.09
	LTE B41_PC3	20	QPSK	1	0	40620	2	6.26	-31.77	38.03
	LTE B41_PC3	20	QPSK	1	0	40620	3	6.18	-32.10	38.28
	LTE B41_PC3	20	QPSK	1	0	40620	4	6.56	-31.99	38.55
	LTE B41_PC3	20	QPSK	1	0	40620	5	6.37	-31.80	38.17
	LTE B41_PC3	20	QPSK	1	0	40620	6	6.20	-31.84	38.04
	UL CA B41_PC3	20	QPSK	1	0	40620	0	6.23	-31.80	38.03
	LTE B41_PC2	20	QPSK	1	0	40620	1	6.24	-31.69	37.93
	LTE B41_PC2	20	QPSK	1	0	40620	2	6.27	-31.84	38.11
	LTE B41_PC2	20	QPSK	1	0	40620	3	6.26	-32.02	38.28
	LTE B41_PC2	20	QPSK	1	0	40620	4	6.31	-32.01	38.32
	LTE B41_PC2	20	QPSK	1	0	40620	5	6.28	-32.10	38.38
	UL CA B41_PC2	20	QPSK	1	0	40620	1	6.44	-31.85	38.29

Plot No.	Air Interface	BW (MHz)	Modulation	RB Size	RB offset	Channel	Probe Position	ABM1 dB (A/m)	ABM2 dB (A/m)	Signal Quality dB	T Rating	Ambient Noise dB (A/m)	Freq. Response Variation dB	Frequency Response
9	LTE Band 7	20	QPSK	1	0	21100	Axial (Z)	5.85	-33.30	39.15	T4	-58.33	1.48	Pass
							Transversal (Y)	-1.68	-40.17	38.49	T4	-50.26		
10	LTE Band 12	10	QPSK	1	0	23095	Axial (Z)	5.76	-33.41	39.17	T4	-50.31	1.79	Pass
							Transversal (Y)	-3.27	-41.65	38.38	T4	-50.24		
11	LTE Band 13	10	QPSK	1	0	23230	Axial (Z)	4.83	-34.64	39.47	T4	-50.35	1.42	Pass
							Transversal (Y)	-2.48	-41.10	38.62	T4	-50.26		
12	LTE Band 25	20	QPSK	1	0	26340	Axial (Z)	5.90	-32.90	38.80	T4	-50.30	1.7	Pass
							Transversal (Y)	-0.91	-45.84	44.93	T4	-50.21		
13	LTE Band 26	15	QPSK	1	0	26865	Axial (Z)	5.50	-33.83	39.33	T4	-50.32	1.96	Pass
							Transversal (Y)	-3.15	-41.77	38.62	T4	-50.25		
14	LTE Band 30	20	QPSK	1	0	27710	Axial (Z)	3.88	-35.46	39.34	T4	-50.33	1.55	Pass
							Transversal (Y)	-2.56	-41.13	38.57	T4	-50.23		
15	LTE Band 66	20	QPSK	1	0	132322	Axial (Z)	6.15	-33.21	39.36	T4	-50.36	1.54	Pass
							Transversal (Y)	-1.67	-40.01	38.34	T4	-50.21		
16	LTE Band 71	20	QPSK	1	0	133322	Axial (Z)	4.84	-34.68	39.52	T4	-50.34	1.87	Pass
							Transversal (Y)	-0.83	-39.42	38.59	T4	-50.22		
17	LTE Band 41	20	QPSK	1	0	40620	Axial (Z)	5.83	-32.96	38.79	T4	-50.37	1.03	Pass
							Transversal (Y)	-3.32	-41.69	38.37	T4	-50.23		
18	LTE Band 48	20	QPSK	1	0	55830	Axial (Z)	4.16	-34.14	38.30	T4	-50.33	1.38	Pass
							Transversal (Y)	-2.09	-39.66	37.57	T4	-50.26		

10.2 VoWiFi Tests Results

General Note:

1. **Codec Investigation:** For a voice service/air interface, investigate the variations of codec configurations (WB, NB bit rate) and document the parameters (ABM1, ABM2, S+N/N, frequency response) for that voice service. It is only necessary to document this for one channel/band, the following worst investigation codec would be remarked to be used for the testing for the handset.
2. **Air Interface Investigation:**
 - a. Use the worst-case codec test and document a limited set of bands/channel/bandwidths. Observe the effect of changing the band and bandwidth to ensure that there are no unexpected variations. Using the knowledge of the observed variations, it is necessary to report only a set band/channel/bandwidth for each orientation for a voice service/air interface and the following worst configure would be remarked to be used for the testing for the handset.
 - b. Select WLAN 2.4GHz and WLAN 5GHz one frequency band to do measurement at the worst SNR position was additionally performed with varying the BWs/Modulations/data rate to verify the variation to find out worst configuration , the observed variation is very little to be within 1 dB which is much less than the margin from the rating threshold.
 - c. According to the ANSI C63.19 2011 section 7.3.2, test middle channel of each frequency band for HAC testing for each orientation to determine worst HAC T-Coil rating.

<Codec Investigation>

Codec	NB AMR 4.75Kbps	WB AMR 6.60Kbps	NB AMR 12.2Kbps	WB AMR 23.85Kbps	EVS SWB 9.6Kbps	EVS SWB 128Kbps	EVS WB 5.9Kbps	EVS WB 128Kbps	EVS NB 5.9Kbps	EVS NB 24.4Kbps	Orientation	Band / Channel
ABM 1 (dBA/m)	4.58	-1.58	4.35	5	1.36	1.43	1.02	1.45	3.25	2.87	Axial	2.4GHz WLAN / 6
ABM 2 (dBA/m)	-34.14	-38.17	-33.9	-32.33	-36.82	-36.19	-32.73	-36.41	-34.13	-38.19		
Signal Quality (dB)	38.72	36.59	38.25	37.33	38.18	37.62	33.75	37.86	37.38	41.06		
Freq. Response	Pass	Pass	Pass	Pass	Pass	Pass	Pass	Pass	Pass	Pass		

Remark: According to codec investigation, the worst codec is EVS WB 5.9Kbps.9Kbps



<Air Interface Investigation>

Frequency Bands	Modulation	Bandwidth	Data Rate	Channel	ABM1 dB (A/m)	ABM2 dB (A/m)	Signal Quality dB
WLAN 2.4GHz	802.11b	20	1M	6	4.56	-31.43	35.99
	802.11b	20	11M	6	4.62	-31.52	36.14
	802.11g	20	6M	6	4.89	-31.72	36.61
	802.11g	20	54M	6	4.58	-31.63	36.21
	802.11n-HT20	20	MCS0	6	4.61	-31.64	36.25
	802.11n-HT20	20	MCS7	6	4.71	-31.55	36.26
	802.11n-HT40	40	MCS0	6	4.56	-31.61	36.17
	802.11n-HT40	40	MCS7	6	4.64	-31.67	36.31
	802.11ax-HE20	20	MCS0	6	4.62	-31.64	36.26
	802.11ax-HE20	20	MCS11	6	4.54	-31.63	36.17
	802.11ax-HE40	40	MCS0	6	4.62	-31.69	36.31
	802.11ax-HE40	40	MCS11	6	4.58	-31.65	36.23
WLAN 5GHz	802.11a	20	6M	40	-0.14	-35.06	34.92
	802.11a	20	54M	40	4.75	-31.43	36.18
	802.11an-HT20	20	MCS0	40	4.95	-31.54	36.49
	802.11an-HT20	20	MCS7	40	4.58	-31.37	35.95
	802.11an-HT40	40	MCS0	38	0.20	-35.47	35.67
	802.11an-HT40	40	MCS7	38	0.74	-34.95	35.69
	802.11ac-VHT20	20	MCS0	40	3.95	-35.05	39.00
	802.11ac-VHT20	20	MCS8	40	4.09	-35.29	39.38
	802.11ac-VHT40	40	MCS0	38	0.73	-35.47	36.20
	802.11ac-VHT40	40	MCS8	38	0.38	-35.44	35.82
	802.11ac-VHT80	80	MCS0	50	4.41	-31.62	36.03
	802.11ac-VHT80	80	MCS8	50	3.76	-35.47	39.23
	802.11ax-HE20	20	MCS0	40	3.93	-35.35	39.28
	802.11ax-HE20	20	MCS11	40	4.13	-35.32	39.45
	802.11ax-HE40	40	MCS0	38	0.78	-35.57	36.35
	802.11ax-HE40	40	MCS11	38	0.35	-35.58	35.93
	802.11ax-HE80	80	MCS0	50	4.46	-31.46	35.92
	802.11ax-HE80	80	MCS11	50	3.88	-35.32	39.20

Plot No.	Air Interface	Mode	Channel	Ant Status	Probe Position	ABM1 dB (A/m)	ABM2 dB (A/m)	Signal Quality dB	T Rating	Ambient Noise dB (A/m)	Freq. Response Variation dB	Frequency Response
19	WLAN2.4GHz	802.11b 1Mbps	6	Ant 1+2	Axial (Z)	1.85	-34.74	36.59	T4	-50.32	2	Pass
					Transversal (Y)	-4.36	-39.88	35.52	T4	-50.21		
20	WLAN5GHz	802.11a 6Mbps	40	Ant 1+2	Axial (Z)	1.55	-35.57	37.12	T4	-50.33	1.47	Pass
					Transversal (Y)	-6.99	-42.61	35.62	T4	-50.20		
21	WLAN5GHz	802.11a 6Mbps	60	Ant 1+2	Axial (Z)	4.84	-31.69	36.53	T4	-50.32	1.75	Pass
					Transversal (Y)	-5.48	-40.62	35.14	T4	-50.26		
22	WLAN5GHz	802.11a 6Mbps	124	Ant 1+2	Axial (Z)	3.61	-32.75	36.36	T4	-50.30	1.63	Pass
					Transversal (Y)	-5.90	-41.07	35.17	T4	-50.21		
23	WLAN5GHz	802.11a 6Mbps	157	Ant 1+2	Axial (Z)	2.11	-34.21	36.32	T4	-50.31	1.48	Pass
					Transversal (Y)	-4.80	-39.88	35.08	T4	-50.24		



11. T-Coil testing for OTT VoIP Application

General Notes:

1. According to the ANSI C63.19 2011 section 7.3.2, test middle channel of each frequency band for HAC testing for each orientation to determine worst HAC T-Coil rating.
2. The google Duo VoIP application are pre-installed on this device. According to KDB 285076 D02, all air interfaces via a data connection with VoIP application need to be considered HAC testing.
3. The Google Duo only support OPUS audio codec and support 6Kbps to 75Kbps bitrate.
4. The test setup used for OTT VoIP call is the DUT connect to the CMW500 and via the data application unit on CMW500 connection to the Internet, the Auxiliary EUT is connected to the WiFi access point, the channel/Modulation/Frequency bands/data rate is configured on the CMW500 for the DUT unit. For the Auxiliary VoIP unit which is used to configure the audio codec rate and determine the audio input level of -20dBm0 based on the KDB 285076 D02v03 requirement.
5. Codec Investigation: For a voice service/air interface, investigate the variations of codec configurations (WB, NB bit rate) and document the parameters (ABM1, ABM2, S+N/N, frequency response) for that voice service. It is only necessary to document this for one channel/band, the following tests results which the worst case codec would be remarked to be used for the testing for the handset.
6. Air Interface Investigation:
 - a. Use the worst-case codec test and document a limited set of bands/channel/bandwidths. Observe the effect of changing the band and bandwidth to ensure that there are no unexpected variations. Using the knowledge of the observed variations, it is necessary to report only a set band/channel/bandwidth for each orientation for a voice service/air interface.
 - b. Due to OTT service and CMRS IP service are all be established over the internet protocol for the voice service, and on both services use the identical RF air interface for the WIFI and LTE, therefore according to VoLTE and VoWiFi test results of air interface investigation, the worst configuration and frequency band of air interface was used for OTT T-Coil testing.
 - LTE FDD worst configuration and band: LTE Band 66/20MHz/QPSK/1RB Size
 - LTE TDD worst configuration and band: LTE Band 41/20MHz/QPSK/1RB Size
 - WLAN2.4GHz Ant 1+2 worst configuration: 802.11b /1Mbps
 - WLAN5GHz Ant 1+2 worst configuration and Band: WLAN 5.2GHz /11a/6Mbps
7. An investigation was performed to determine the modulation and RB configuration to be used for NR band n2/n5/n66/n71/n41 testing. Due to equipment limitation, the worst-case AMB1 from LTE B66/B41 were used with the AMM2 measured for each NR band n2/n5/n66/n71/n41 modulation and RB configuration.
8. Due to equipment limitation, ABM1 and frequency response measurement were not possible. Therefore, the worst-case ABM1 measurement from LTE FDD/TDD OTT VoIP testing for Axial and Radial were combined with 5G n2/n5/n66/n71/n41 ABM2 measurement to obtain SNNR values.

<Codec Investigation>
EDGE

Google Duo				SIP Calling					Orientation	Band / Channel
Codec	Opus 6kbps	Opus 40kbps	Opus 75kbps	AMR NB 12.2 Kbit/s	GSM 13Kbit/s	GSM_EFR 12.2 Kbit/s	PCMA 64 Kbit/s	PCMU 64 Kbit/s		
ABM 1 (dBA/m)	5.12	-3.55	-3.05	6.49	5.4	6.62	5.04	5.79	Axial	GSM850 / 189
ABM 2 (dBA/m)	-34.39	-37.87	-36.88	-27.81	-28.37	-27.58	-28.26	-28.22		
Signal Quality (dB)	39.51	34.32	33.83	34.3	33.77	34.2	33.3	34.01		
Freq. Response	Pass	Pass	Pass	Pass	Pass	Pass	Pass	Pass		

Remark: According to codec investigation, the worst codec bitrate is PCMA 64 Kbit/s.

HSPA

Google Duo				SIP Calling					Orientation	Band / Channel
Codec	Opus 6kbps	Opus 40kbps	Opus 75kbps	AMR NB 12.2 Kbit/s	GSM 13Kbit/s	GSM_EFR 12.2 Kbit/s	PCMA 64 Kbit/s	PCMU 64 Kbit/s		
ABM 1 (dBA/m)	12.4	13.11	12.72	5.35	6.27	5.16	6.39	4.79	Axial	UMTS B5 / 4182
ABM 2 (dBA/m)	-46.89	-46.44	-46.28	-35.19	-33.56	-35.8	-32.84	-34.67		
Signal Quality (dB)	59.29	59.55	59	40.54	39.83	40.96	39.23	39.46		
Freq. Response	Pass	Pass	Pass	Pass	Pass	Pass	Pass	Pass		

Remark: According to codec investigation, the worst codec bitrate is PCMA 64 Kbit/s.

1XEVD0 Rev A

Google Duo				SIP Calling					Orientation	Band / Channel
Codec	Opus 6kbps	Opus 40kbps	Opus 75kbps	AMR NB 12.2 Kbit/s	GSM 13Kbit/s	GSM_EFR 12.2 Kbit/s	PCMA 64 Kbit/s	PCMU 64 Kbit/s		
ABM 1 (dBA/m)	12.33	12.06	11.96	0.21	3.34	3.73	3.12	3.12	Axial	BC0 / 384
ABM 2 (dBA/m)	-45.76	-46.02	-45.69	-40.28	-34.64	-35.37	-34.51	-34.69		
Signal Quality (dB)	58.09	58.08	57.65	40.49	37.98	39.1	37.63	37.81		
Freq. Response	Pass	Pass	Pass	Pass	Pass	Pass	Pass	Pass		

Remark: According to codec investigation, the worst codec bitrate is PCMA 64 Kbit/s.

LTE FDD

Google Duo				SIP Calling					Orientation	Band / Channel
Codec	Opus 6kbps	Opus 40kbps	Opus 75kbps	AMR NB 12.2 Kbit/s	GSM 13Kbit/s	GSM_EFR 12.2 Kbit/s	PCMA 64 Kbit/s	PCMU 64 Kbit/s		
ABM 1 (dBA/m)	7.96	7.16	8.04	3.47	2.73	3.38	3.98	4.8	Axial	B66 / 20M / 132322
ABM 2 (dBA/m)	-47.07	-47.3	-45.37	-34.81	-34.65	-34.16	-31.91	-32.54		
Signal Quality (dB)	55.03	54.46	53.41	38.28	37.38	37.54	35.89	37.34		
Freq. Response	Pass	Pass	Pass	Pass	Pass	Pass	Pass	Pass		

Remark: According to codec investigation, the worst codec bitrate is PCMA 64 Kbit/s.



LTE TDD

Google Duo				SIP Calling					Orientation	Band / Channel
Codec	Opus 6kbps	Opus 40kbps	Opus 75kbps	AMR NB 12.2 Kbit/s	GSM 13Kbit/s	GSM_EFR 12.2 Kbit/s	PCMA 64 Kbit/s	PCMU 64 Kbit/s		
ABM 1 (dBA/m)	7.11	6.52	11.8	3.67	3.85	3.68	4.05	3.73	Axial	B41 / 20M / 40620
ABM 2 (dBA/m)	-46.16	-46	-37.63	-34.62	-33.59	-34.61	-33.12	-33.5		
Signal Quality (dB)	53.27	52.52	49.43	38.29	37.44	38.29	37.17	37.23		
Freq. Response	Pass	Pass	Pass	Pass	Pass	Pass	Pass	Pass		

Remark: According to codec investigation, the worst codec bitrate is PCMA 64 Kbit/s.

WLAN

Google Duo				SIP Calling					Orientation	Band / Channel
Codec	Opus 6kbps	Opus 40kbps	Opus 75kbps	AMR NB 12.2 Kbit/s	GSM 13Kbit/s	GSM_EFR 12.2 Kbit/s	PCMA 64 Kbit/s	PCMU 64 Kbit/s		
ABM 1 (dBA/m)	11.83	12.08	11.54	3.77	3.04	4.42	3.93	5.9	Axial	WLAN2.4G / 6
ABM 2 (dBA/m)	-44.4	-43.76	-44.15	-35.36	-34.96	-34.63	-33.78	-32.61		
Signal Quality (dB)	56.23	55.84	55.69	39.13	38	39.05	37.71	38.51		
Freq. Response	Pass	Pass	Pass	Pass	Pass	Pass	Pass	Pass		

Remark: According to codec investigation, the worst codec bitrate is PCMA 64 Kbit/s.



Plot No.	Air Interface	Modulation / Mode	Channel	Ant Status	Probe Position	ABM1 dB (A/m)	ABM2 dB (A/m)	Signal Quality dB	T Rating	Ambient Noise dB (A/m)	Freq. Response Variation dB	Frequency Response
24	GSM850	EDGE 2 Tx slots	189	-	Axial (Z)	5.04	-28.26	33.30	T4	-50.34	0.68	Pass
					Transversal (Y)	-1.28	-36.05	34.77	T4	-50.21		
25	GSM1900	EDGE 2 Tx slots	661	-	Axial (Z)	4.67	-29.60	34.27	T4	-50.37	0.79	Pass
					Transversal (Y)	-4.97	-40.01	35.04	T4	-50.20		
26	WCDMA II	HSPA	9400	-	Axial (Z)	4.86	-34.51	39.37	T4	-50.33	0.67	Pass
					Transversal (Y)	-0.57	-39.20	38.63	T4	-50.28		
27	WCDMA IV	HSPA	1413	-	Axial (Z)	4.31	-35.25	39.56	T4	-50.32	0.72	Pass
					Transversal (Y)	-1.23	-40.02	38.79	T4	-50.26		
28	WCDMA V	HSPA	4182	-	Axial (Z)	6.39	-32.84	39.23	T4	-50.36	0.95	Pass
					Transversal (Y)	-1.13	-39.66	38.53	T4	-50.22		
29	CDMA BC0	RTAP 153.6Kbps	384	-	Axial (Z)	3.12	-34.51	37.63	T4	-50.33	0.71	Pass
					Transversal (Y)	-3.56	-40.32	36.76	T4	-50.28		
30	CDMA BC1	RTAP 153.6Kbps	600	-	Axial (Z)	3.22	-34.59	37.81	T4	-50.35	0.72	Pass
					Transversal (Y)	-3.60	-40.44	36.84	T4	-50.26		
31	CDMA BC10	RTAP 153.6Kbps	580	-	Axial (Z)	3.07	-34.67	37.74	T4	-50.31	0.75	Pass
					Transversal (Y)	-3.18	-40.09	36.91	T4	-50.25		
32	LTE Band 66	20M_QPSK_1_0	132322	-	Axial (Z)	3.98	-31.91	35.89	T4	-50.38	0.77	Pass
					Transversal (Y)	-6.36	-43.16	36.80	T4	-50.28		
33	LTE Band 41	20M_QPSK_1_0	40620	-	Axial (Z)	4.05	-33.12	37.17	T4	-50.35	0.73	Pass
					Transversal (Y)	-4.71	-40.85	36.14	T4	-50.24		
34	WLAN2.4GHz	802.11b 1Mbps	6	Ant 1+2	Axial (Z)	3.93	-33.78	37.71	T4	-50.36	0.63	Pass
					Transversal (Y)	-6.30	-42.11	35.81	T4	-50.26		
35	WLAN5GHz	802.11a 6Mbps	157	Ant 1+2	Axial (Z)	4.18	-33.51	37.69	T4	-50.35	0.82	Pass
					Transversal (Y)	-6.72	-42.51	35.79	T4	-50.28		
	5G NR n2	20M_QPSK_1_1	376000	-	Axial (Z)	3.98	-32.90	36.88	T4	-50.38	na	na
					Transversal (Y)	-6.36	-45.84	39.48	T4	-50.28		
	5G NR n5	20M_QPSK_1_1	1673000	-	Axial (Z)	3.98	-33.83	37.81	T4	-50.33	na	na
					Transversal (Y)	-6.36	-41.77	35.41	T4	-50.31		
	5G NR n66	20M_QPSK_1_1	349000	-	Axial (Z)	3.98	-33.21	37.19	T4	-50.52	na	na
					Transversal (Y)	-6.36	-40.01	33.65	T4	-50.18		
	5G NR n71	20M_QPSK_1_1	1361000	-	Axial (Z)	3.98	-34.68	38.66	T4	-50.28	na	na
					Transversal (Y)	-6.36	-39.42	33.06	T4	-50.19		
	5G NR n41	100M_QPSK_1_1	518598	-	Axial (Z)	4.05	-32.96	37.01	T4	-50.22	na	na
					Transversal (Y)	-4.71	-41.69	36.98	T4	-50.36		

Remark:

1. Phone Condition: Mute on; Backlight off; Max Volume
2. The detail frequency response results please refer to appendix A.
3. Test Engineer : Tom Jiang

12. Uncertainty Assessment

The evaluation of uncertainty by the statistical analysis of a series of observations is termed a Type A evaluation of uncertainty. The evaluation of uncertainty by means other than the statistical analysis of a series of observation is termed a Type B evaluation of uncertainty. Each component of uncertainty, however evaluated, is represented by an estimated standard deviation, termed standard uncertainty, which is determined by the positive square root of the estimated variance. The combined standard uncertainty of the measurement result represents the estimated standard deviation of the result. It is obtained by combining the individual standard uncertainties of both Type A and Type B evaluation using the usual “root-sum-squares” (RSS) methods of combining standard deviations by taking the positive square root of the estimated variances. Expanded uncertainty is a measure of uncertainty that defines an interval about the measurement result within which the measured value is confidently believed to lie. It is obtained by multiplying the combined standard uncertainty by a coverage factor. For purpose of this document, a coverage factor two is used, which corresponds to confidence interval of about 95 %. The DASY uncertainty Budget is showed in Table 8.2. The judgment of conformity in the report is based on the measurement results excluding the measurement uncertainty.

Error Description	Uncertainty Value (±%)	Probability Distribution	Divisor	Ci (ABM1)	Ci (ABM2)	Standard Uncertainty (ABM1)	Standard Uncertainty (ABM2)
Probe Sensitivity							
Reference Level	3.0	Normal	1	1	1	± 3.0 %	± 3.0 %
AMCC Geometry	0.4	Rectangular	√3	1	1	± 0.2 %	± 0.2 %
AMCC Current	1.0	Rectangular	√3	1	1	± 0.6 %	± 0.6 %
Probe Positioning During Calibrate	0.1	Rectangular	√3	1	1	± 0.1 %	± 0.1 %
Noise Contribution	0.7	Rectangular	√3	0.0143	1	± 0.0 %	± 0.4 %
Frequency Slope	5.9	Rectangular	√3	0.1	1	± 0.3 %	± 3.5 %
Probe System							
Repeatability / Drift	1.0	Rectangular	√3	1	1	± 0.6 %	± 0.6 %
Linearity / Dynamic Range	0.6	Rectangular	√3	1	1	± 0.4 %	± 0.4 %
Acoustic Noise	1.0	Rectangular	√3	0.1	1	± 0.1 %	± 0.6 %
Probe Angle	2.3	Rectangular	√3	1	1	± 1.4 %	± 1.4 %
Spectral Processing	0.9	Rectangular	√3	1	1	± 0.5 %	± 0.5 %
Integration Time	0.6	Normal	1	1	5	± 0.6 %	± 3.0 %
Field Disturbation	0.2	Rectangular	√3	1	1	± 0.1 %	± 0.1 %
Test Signal							
Reference Signal Spectral Response	0.6	Rectangular	√3	0	1	± 0.0 %	± 0.4 %
Positioning							
Probe Positioning	1.9	Rectangular	√3	1	1	± 1.1 %	± 1.1 %
Phantom Thickness	0.9	Rectangular	√3	1	1	± 0.5 %	± 0.5 %
EUT Positioning	1.9	Rectangular	√3	1	1	± 1.1 %	± 1.1 %
External Contributions							
RF Interference	0.0	Rectangular	√3	1	0.3	± 0.0 %	± 0.0 %
Test Signal Variation	2.0	Rectangular	√3	1	1	± 1.2 %	± 1.2 %
Combined Standard Uncertainty						± 4.1 %	± 6.1 %
Coverage Factor for 95 %						K = 2	
Expanded Uncertainty						± 8.1 %	± 12.3 %

Table 8.2 Uncertainty Budget of audio band magnetic measurement



13. References

- [1] ANSI C63.19-2011, "American National Standard for Methods of Measurement of Compatibility between Wireless Communications Devices and Hearing Aids", 27 May 2011.
- [2] FCC KDB 285076 D01v05, "Equipment Authorization Guidance for Hearing Aid Compatibility", Sep 2017
- [3] FCC KDB 285076 D02v03, "Guidance for performing T-Coil tests for air interfaces supporting voice over IP (e.g., LTE and WiFi) to support CMRS based telephone services", Sep 2017
- [4] FCC KDB 285076 D03v01, "Hearing aid compatibility frequently asked questions", Sep 2017
- [5] SPEAG DASY System Handbook