



# FCC Part 96.47 TEST REPORT

**FCC ID** : 2ABZ2-EE103  
**Equipment** : Smart Phone  
**Brand Name** : ONEPLUS  
**Model Name** : IN2015  
**Applicant** : OnePlus Technology (Shenzhen) Co., Ltd  
18C02, 18C03, 18C04 and 18C05, Shum Yip  
Terra Building, Binhe Avenue North, Futian  
District, Shenzhen  
**Manufacturer** : OnePlus Technology (Shenzhen) Co., Ltd  
18C02, 18C03, 18C04 and 18C05, Shum Yip  
Terra Building, Binhe Avenue North, Futian  
District, Shenzhen  
**Standard** : FCC Part 96.47

The product was received on Nov. 20, 2019 and testing was started from Dec. 25, 2019 and completed on Dec. 25, 2019. We, SPORTON INTERNATIONAL INC. EMC & Wireless Communications Laboratory, would like to declare that the tested sample has been evaluated in accordance with the test procedures and has been in compliance with the applicable technical standards.

The report must not be used by the client to claim product certification, approval, or endorsement by TAF or any agency of government.

The test results in this report apply exclusively to the tested model / sample. Without written approval of SPORTON INTERNATIONAL INC. EMC & Wireless Communications Laboratory, the test report shall not be reproduced except in full.

Approved by: Jones Tsai

**SPORTON INTERNATIONAL INC. EMC & Wireless Communications Laboratory**  
No. 52, Huaya 1st Rd., Guishan Dist., Taoyuan City, Taiwan (R.O.C.)



## Table of Contents

<b>History of this test report.....</b>	<b>3</b>
<b>Summary of Test Result.....</b>	<b>4</b>
<b>1 General Description .....</b>	<b>5</b>
1.1 Product Feature of Equipment Under Test.....	5
1.2 Modification of EUT .....	5
1.3 Testing Location .....	5
1.4 Applicable Standards.....	5
<b>2 Test Configuration of Equipment Under Test .....</b>	<b>6</b>
2.1 Connection Diagram of Test System.....	6
<b>3 End User Device additional requirement .....</b>	<b>7</b>
3.1 Test Requirement .....	7
3.2 Test Procedure .....	7
3.3 Test Result.....	8
<b>4 List of Measuring Equipment.....</b>	<b>10</b>





### Summary of Test Result

Report Clause	Ref Std. Clause	Test Items	Result (PASS/FAIL)	Remark
3	96.47	End User Device additional requirement	Pass	-

**Note:** The FG9N2021-03A report reuses test data from the FG9N2021-02A report.

<b>Declaration of Conformity:</b>
The test results with all measurement uncertainty excluded are presented in accordance with the regulation limits or requirements declared by manufacturers.
<b>Comments and Explanations:</b>
The declared of product specification for EUT presented in the report are provided by the manufacturer, and the manufacturer takes all the responsibilities for the accuracy of product specification.

**Reviewed by:** William Chen

**Report Producer:** Yimin Ho



# 1 General Description

## 1.1 Product Feature of Equipment Under Test

GSM/CDMA/WCDMA/LTE/5G NR, Bluetooth, Wi-Fi 2.4GHz 802.11b/g/n/ax, Wi-Fi 5GHz 802.11a/n/ac/ax, NFC, and GNSS.

Product Specification subjective to this standard	
<b>Antenna Type</b>	WWAN: PIFA Antenna WLAN: <Ant. 1> PIFA Antenna <Ant. 2> PIFA Antenna Bluetooth: PIFA Antenna GPS / Glonass / BDS / Galileo / SBAS: IFA Antenna NFC: Loop Antenna

## 1.2 Modification of EUT

No modifications are made to the EUT during all test items.

## 1.3 Testing Location

<b>Test Site</b>	SPORTON INTERNATIONAL INC. EMC & Wireless Communications Laboratory
<b>Test Site Location</b>	No.52, Huaya 1st Rd., Guishan Dist., Taoyuan City, Taiwan (R.O.C.) TEL: +886-3-327-3456 FAX: +886-3-328-4978
<b>Test Site No.</b>	<p style="text-align: center;"><b>Sporton Site No.</b></p> <p style="text-align: center;">DFS02-HY</p>

**Note:** The test site complies with ANSI C63.4 2014 requirement.

FCC Designation No.: TW1190

## 1.4 Applicable Standards

- ♦ FCC Part 96.47
- ♦ FCC KDB 940660 D01 Part 96 CBRS Eqpt v02
- ♦ WINNF-TS-0122-V1.0.1 CBRS CBSD Test Specification

**Remark:** All test items were verified and recorded according to the standards and without any deviation during the test.

## 2 Test Configuration of Equipment Under Test

### 2.1 Connection Diagram of Test System

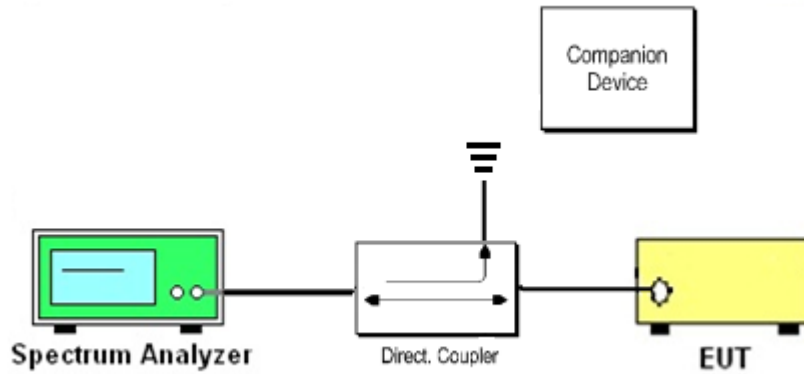

The companion device is certified CBRS (FCC ID: S9GQ910US00)



### 3 End User Device additional requirement

#### 3.1 Test Requirement

FCC Part 96.47

(a) End User Devices may operate only if they can positively receive and decode an authorization signal transmitted by a CBSD, including the frequencies and power limits for their operation.

(1) An End User Device must discontinue operations, change frequencies, or change its operational power level within 10 seconds of receiving instructions from its associated CBSD.

#### 3.2 Test Procedure

Following procedure can be done by applying WINNF-TS-0122-V1.0.1 CBRS CBSD Test Specification, use the certified Ruckus CBSD (FCC ID: S9GQ910US00) as companion device to show compliance with Part 96.47 requirement for End User Device (EUD):

1. Setup with frequency 3600-3620MHz and power level 7dBm/MHz
2. Enable AP service from Ruckus Cloud management
3. Check EUD Tx Frequency and power
4. Disable AP service from Ruckus Cloud management
  - a. Check EUD stops transmission within 10seconds.
5. Setup with 3670-3690MHz & power level 17dBm/MHz
6. Enable AP service from Ruckus Cloud management
7. Check EUD Tx Frequency and power
8. Disable AP service from Ruckus Cloud management
  - a. Check EUD stops transmission within 10seconds.



### 3.3 Test Result

[Step 1] Setup with frequency 3600-3620MHz and power level 7dBm/MHz

[Step 3] Check EUD Tx Frequency and power

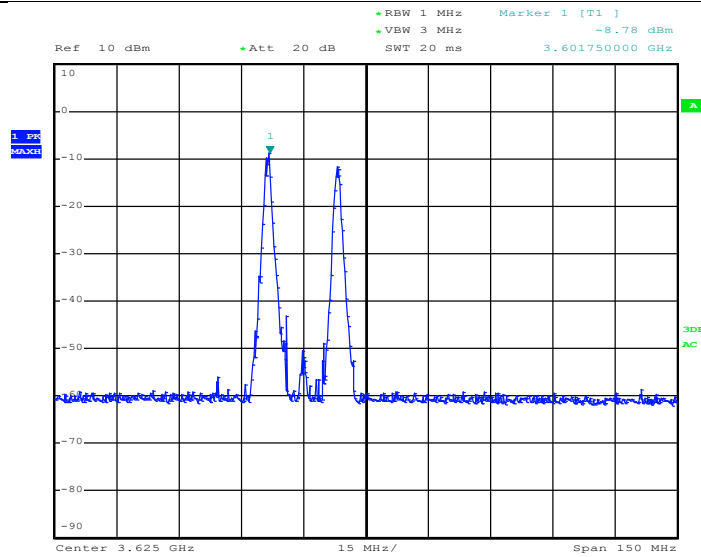

Date: 25.DEC.2019 10:41:03

[Step 4.a.] EUD stops transmission within 10 seconds of receiving instructions from its associated CBSD.

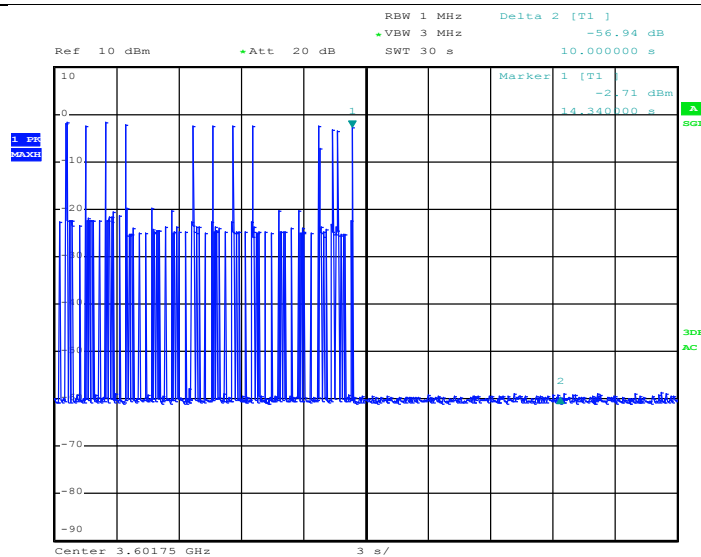

Date: 25.DEC.2019 10:44:20





[Step 5] Setup with 3670-3690MHz & power level 17dBm/MHz

[Step 7] Check EUD Tx Frequency and power

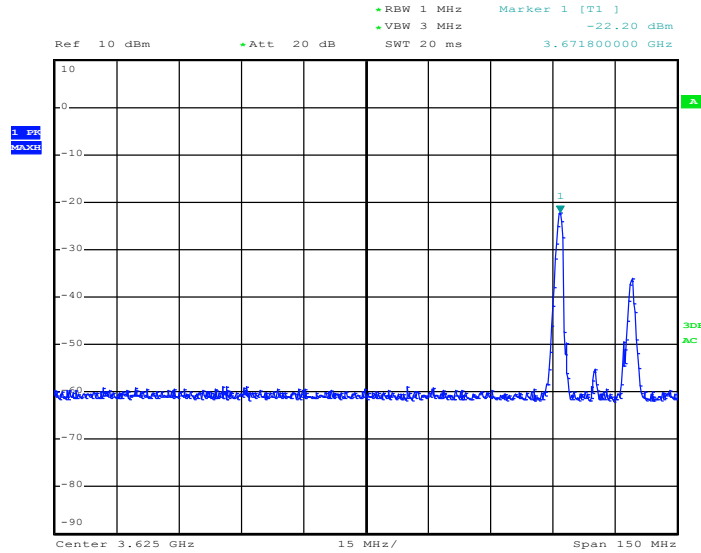

Date: 25.DEC.2019 10:50:20

[Step 8.a.] After changing the frequency and power level, The module (EUT) discontinues operations, change frequencies, or change its operational power level within 10 seconds of receiving instructions from its associated CBSD. Test result is PASS.

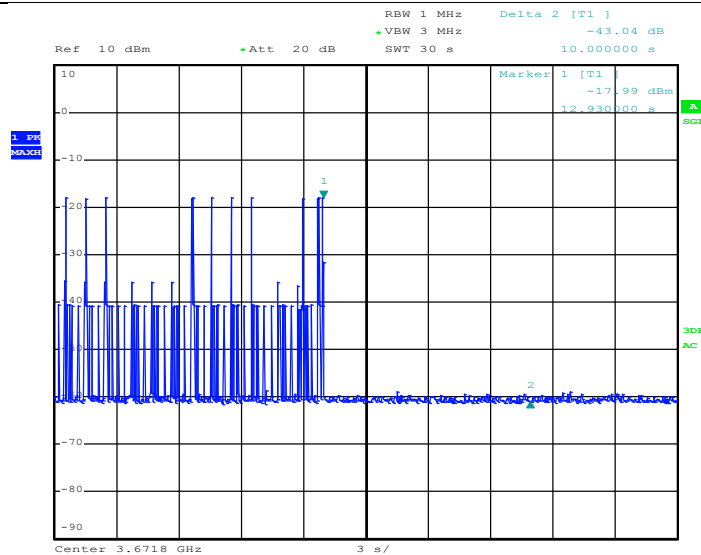

Date: 25.DEC.2019 10:59:06



## 4 List of Measuring Equipment

Instrument	Manufacturer	Model No.	Serial No.	Characteristics	Calibration Date	Test Date	Due Date	Remark
Spectrum Analyzer	Rohde & Schwarz	ESCI 7	100724	9kHz~7GHz	Oct. 24, 2019	Dec. 25, 2019	Oct. 23, 2020	DFS02-HY