



中国认可  
国际互认  
检测  
TESTING  
CNAS L0446



Page 1 of 47

# Test Report

Verified code: 904804

Report No.: E20220126055701-5

Customer: OnePlus Technology (Shenzhen) Co., Ltd.  
Address: 18C02, 18C03, 18C04 and 18C05, Shum Yip Terra Building, Binhe Avenue North, Futian District, Shenzhen, China  
Sample Name: Wireless earphones  
Sample Model: E505A  
Receive Sample Date: Feb.14,2022  
Test Date: Feb.15,2022 ~ Mar.03,2022  
Reference Document: CFR 47, FCC Part 15 Subpart C  
RADIO FREQUENCY DEVICES:Subpart C—Intentional Radiators  
Test Result: Pass

Prepared by: Yang Zhaoyun

Reviewed by:

Jiang Tao

Approved by:

Xiao Liang

GUANGZHOU GRG METROLOGY & TEST CO., LTD

Issued Date: 2022-03-24

GUANGZHOU GRG METROLOGY & TEST CO., LTD.

Address: No.163, Pingyun Road, West of Huangpu Avenue, Guangzhou, Guangdong, China

Tel: (+86) 400-602-0999 FAX: (+86) 020-38698685 Web: <http://www.grgtest.com>



## Statement

1. The report is invalid without "special seal for inspection and testing"; some copies are invalid; The report is invalid if it is altered or missing; The report is invalid without the signature of the person who prepared, reviewed and approved it.
2. The sample information is provided by the client and responsible for its authenticity; The content of the report is only valid for the samples sent this time.
3. When there are reports in both Chinese and English, the Chinese version will prevail when the language problems are inconsistent.
4. If there is any objection concerning the report, please inform us within 15 days from the date of receiving the report.
5. Without the agreement of the laboratory, the client is not authorized to use the test results for unapproved propaganda.

----- The following blanks -----

## Table of Contents

1.	TEST RESULT SUMMARY.....	5
2.	GENERAL DESCRIPTION OF EUT.....	6
2.1	APPLICANT.....	6
2.2	MANUFACTURER.....	6
2.3	FACTORY.....	6
2.4	BASIC DESCRIPTION OF EQUIPMENT UNDER TEST.....	6
2.5	CHANNELLIST.....	7
2.6	TEST OPERATION MODE.....	7
2.7	LOCAL SUPPORTIVE.....	7
2.8	CONFIGURATION OF SYSTEM UNDER TEST.....	7
2.9	DUTY CYCLE.....	8
3.	LABORATORY AND ACCREDITATIONS.....	9
3.1	LABORATORY.....	9
3.2	ACCREDITATIONS.....	9
3.3	MEASUREMENT UNCERTAINTY.....	10
4.	LIST OF USED TEST EQUIPMENT AT GRGT.....	11
5.	RADIATED SPURIOUS EMISSIONS.....	12
5.1	LIMITS.....	12
5.2	TEST PROCEDURES.....	12
5.3	TEST SETUP.....	15
5.4	DATA SAMPLE.....	16
5.5	TEST RESULTS.....	17
6.	6dB BANDWIDTH.....	26
6.1	LIMITS.....	26
6.2	TEST PROCEDURES.....	26
6.3	TEST SETUP.....	26
6.4	TEST RESULTS.....	26
7.	MAXIMUM PEAK OUTPUT POWER.....	29
7.1	LIMITS.....	29
7.2	TEST PROCEDURES.....	29
7.3	TEST SETUP.....	29
7.4	TEST RESULTS.....	29
8.	POWER SPECTRAL DENSITY.....	30
8.1	LIMITS.....	30
8.2	TEST PROCEDURES.....	30
8.3	TEST SETUP.....	30
8.4	TEST RESULTS.....	30
9.	CONDUCTED BAND EDGES AND SPURIOUS EMISSIONS.....	33
9.1	LIMITS.....	33
9.2	TEST PROCEDURES.....	33
9.3	TEST SETUP.....	33
9.4	TEST RESULTS.....	34
10.	RESTRICTED BANDS OF OPERATION.....	41

10.1 LIMITS..... 41

10.2 TEST PROCEDURES ..... 42

10.3 TEST SETUP ..... 42

10.4 TEST RESULTS ..... 43

APPENDIX A. PHOTOGRAPH OF THE TEST CONNECTION DIAGRAM ..... 47

APPENDIX B. PHOTOGRAPH OF THE EUT ..... 47

----- The following blanks -----

**1. TEST RESULT SUMMARY**

<b>Technical Requirements</b>		
FCC 47 CFR Part 15 Subpart C 15.247 ANSI C63.10-2013 KDB 558074 D01 15.247 measurement guidance v05r02		
<b>Limit / Severity</b>	<b>Item</b>	<b>Result</b>
§15.203	Antenna Requirement	Pass
§15.207(a)	Conducted Emission	Not Applicable
§15.247(d)	Radiated Spurious Emission	Pass
§15.247(b)(3)	Maximum Peak Output Power	Pass
§15.247(e)	Power Spectral Density	Pass
§15.247(a)(2)	6dB bandwidth	Pass
§15.247(d)	Conducted band edges and Spurious Emission	Pass
§15.205	Restricted bands of operation	Pass

The EUT has one antenna. The antenna is FPC antenna.  
The max gain of antenna is -0.5dBi, which accordance 15.203, is considered sufficient to comply with the provisions of this section.

----- The following blanks -----

## 2. GENERAL DESCRIPTION OF EUT

### 2.1 APPLICANT

Name: OnePlus Technology (Shenzhen) Co., Ltd.  
Address: 18C02, 18C03, 18C04 and 18C05, Shum Yip Terra Building, Binhe Avenue North, Futian District, Shenzhen, China

### 2.2 MANUFACTURER

Name: OnePlus Technology (Shenzhen) Co., Ltd.  
Address: 18C02, 18C03, 18C04 and 18C05, Shum Yip Terra Building, Binhe Avenue North, Futian District, Shenzhen, China

### 2.3 FACTORY

Name: Jiangxi Risound Electronics Co., Ltd.  
Address: No.271, Innovation Avenue, Jinggangshan Economic and Technological Development Zone, Ji'an City, Jiangxi Province

### 2.4 BASIC DESCRIPTION OF EQUIPMENT UNDER TEST

Equipment:	Wireless earphones
Model No.:	E505A
Adding Model:	/
Models discrepancy:	/
Trade Name:	ONEPLUS
FCC ID:	2ABZ2-E505AR
Power supply:	DC 3.8V power supplied by earphones battery DC 5V power supplied by E505A charging case or DC 3.7V power supplied by charging case battery E505A
Charging Case:	Input: 5.0V --- 0.9A Output: 5.0V --- 0.3A Rated Capacity:480mAh 1.77Wh Rechargeable Li-ion Battery, Model:751443-1
Charging Case Battery Specification:	Rated Voltage:3.7Vdc Rated Capacity:480mAh 1.77Wh Limited Charge voltage:4.35Vdc Rechargeable Li-ion Cell , Model:1058PF3
Earphones Battery Specification:	Rated Voltage:3.8Vdc Rated Capacity:41mAh 0.155Wh
Frequency Range:	2402 ~ 2480MHz
Transmit Power:	GFSK:4.97dBm
Modulation type:	GFSK
Channel space:	2MHz
Antenna Specification:	FPC antenna -0.5dBi gain (Max.)
Temperature Range:	0°C~35°C

Hardware Version: AA460\_0  
 Software Version: V1.0.0  
 Sample No: E20220126055701-0006  
 E20220126055701-0010  
 Note: Earphone is E505A, Charging Case is E505A

**2.5 CHANNELLIST**

Channel	Frequency (MHz)	Channel	Frequency (MHz)	Channel	Frequency (MHz)	Channel	Frequency (MHz)
00	2402	10	2422	20	2442	30	2462
01	2404	11	2424	21	2444	31	2464
02	2406	12	2426	22	2446	32	2466
03	2408	13	2428	23	2448	33	2468
04	2410	14	2430	24	2450	34	2470
05	2412	15	2432	25	2452	35	2472
06	2414	16	2434	26	2454	36	2474
07	2416	17	2436	27	2456	37	2476
08	2418	18	2438	28	2458	38	2478
09	2420	19	2440	29	2460	39	2480

**2.6 TEST OPERATION MODE**

Mode No.	Description of the modes
1	Bluetooth BLE fixed frequency transmitting

**2.7 LOCAL SUPPORTIVE**

Name of Equipment	Manufacturer	Model	Serial Number	Note
Notebook	LENOVO	TianYi 310-14ISK	MP18DLC6	/

**2.8 CONFIGURATION OF SYSTEM UNDER TEST**

EUT

Test software:

Software version	Test level
BQB.exe	/

**2.9 DUTY CYCLE**

Environment: 23.4°C/52%RH  
 Tested By: Lu Wei

Voltage: DC 3.8V  
 Date: 2022/02/16

Test Mode	Antenna	Frequency	ON Time [ms]	Period [ms]	DC [%]	T [s]
BLE_1M	Ant1	2440	0.401	0.625	64.16	0.000401

**BLE\_1M\_2440**

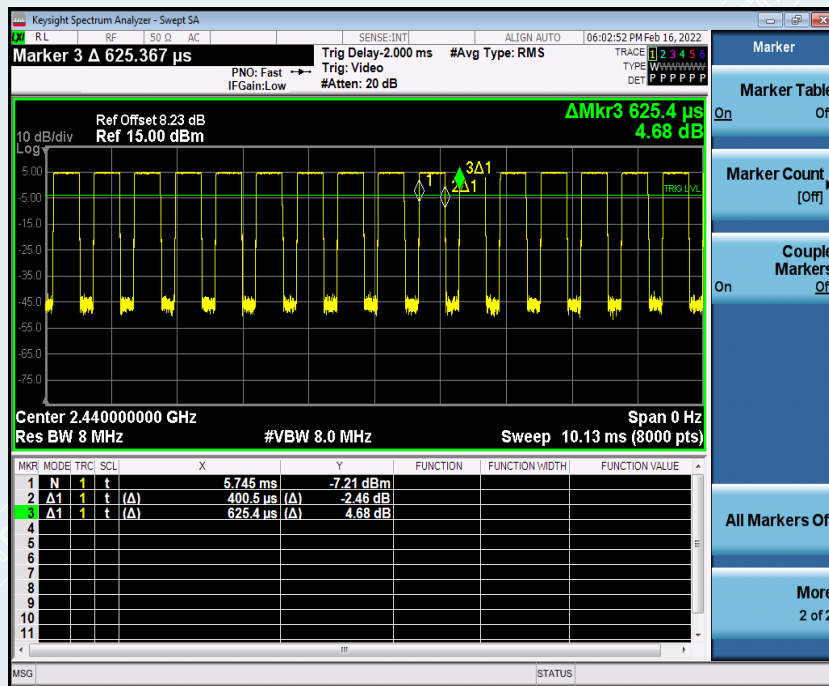

----- The following blanks -----



### 3. LABORATORY AND ACCREDITATIONS

#### 3.1 LABORATORY

The tests & measurements refer to this report were performed by Shenzhen EMC Laboratory of Guangzhou GRG Metrology & Test Co., Ltd.

Add : No.1301 Guangang Road Xinlan Community, Guanlan Street, Longhua District  
Shenzhen, 518110, People's Republic of China

P.C. : 518000

Tel : 0755-61180008

Fax : 0755-61180008

#### 3.2 ACCREDITATIONS

Our laboratories are accredited and approved by the following approval agencies according to ISO/IEC 17025.

**USA** A2LA(Certificate #2861.01)

**China** CNAS(L0446)

The measuring facility of laboratories has been authorized or registered by the following approval agencies.

**Canada** ISED (Company Number: 24897, CAB identifier:CN0069)

**USA** FCC (Registration Number: 759402, Designation Number:CN1198)

Copies of granted accreditation certificates are available for downloading from our web site,  
<http://www.grgtest.com>

----- The following blanks -----

**3.3 MEASUREMENT UNCERTAINTY**

Where relevant, the following measurement uncertainty levels have been estimated for tests performed on the EUT as specified in CISPR 16-4-2:

Measurement		Frequency	Uncertainty
Radiated Emission	Horizontal	9kHz~30MHz	4.46dB
		30MHz~1000MHz	4.30dB
		1GHz~18GHz	5.60dB
		18GHz~26.5GHz	3.65dB
	Vertical	9kHz~30MHz	4.46dB
		30MHz~1000MHz	4.30dB
		1GHz~18GHz	5.60dB
		18GHz~26.5GHz	3.65dB

Measurement	Uncertainty
RF frequency	$6.0 \times 10^{-6}$
RF power conducted	0.78 dB
Occupied channel bandwidth	0.4 dB
Unwanted emission, conducted	0.68 dB
Humidity	6 %
Temperature	2 °C

This uncertainty represents an expanded uncertainty factor of  $k=2$ .

----- The following blanks -----

**4. LIST OF USED TEST EQUIPMENT AT GRGT**

Name of Equipment	Manufacturer	Model	Serial Number	Calibration Due
<b>Radiated Spurious Emission&amp;Restricted bands of operation</b>				
Test S/W	EZ	CCS-2ANT	/	/
Test Receiver	R&S	ESCI	100088	2022-10-31
Preamplifier	EMEC	EM330	/	2022-03-21
Loop Antenna	TESEQ	HLA6121	52599	2022-04-21
Bi-log Antenna	TESEQ	CBL6143A	32399	2022-11-25
Spectrum Analyzer	Agilent	N9010A	MY52221469	2022-04-16
Loop Antenna	TESEQ	HLA6121	52599	2022-04-21
Horn Antenna	Schwarzbeck	BBHA9120D (1201)	02143	2022-10-22
Board-Band Horn Antenna	Schwarzbeck	BBHA 9170	BBHA9170-497	2022-10-16
Amplifier	Tonscend	TAP01018048	AP20E8060075	2022-05-09
Amplifier	Tonscend	TAP184050	AP20E806071	2022-05-17
Test S/W	Tonscend	JS36-RSE/2.5.1.5		
<b>6dB Bandwidth</b>				
Spectrum Analyzer	Agilent	N9010A	MY52221469	2022-04-16
<b>Maximum Peak Output Power</b>				
Pulse power sensor	Agilent	MA2411B	1126150	2022-03-21
Power meter	Anritsu	ML2495A	1204003	2022-03-21
<b>Conducted band edges and Spurious Emission</b>				
Spectrum Analyzer	Agilent	N9010A	MY52221469	2022-04-16
<b>Power Spectral Density</b>				
Spectrum Analyzer	Agilent	N9010A	MY52221469	2022-04-16

Note: The calibration interval of the above test instruments is 12 months.

## 5. RADIATED SPURIOUS EMISSIONS

### 5.1 LIMITS

In any 100kHz bandwidth outside the frequency band in which the spread spectrum or digitally modulated intentional radiator is operating, the radio frequency power that is produced by the intentional radiator shall be at least 20dB below that in the 100kHz bandwidth within the band that contains the highest level of the desired power, based on either an RF conducted or a radiated measurement, provided the transmitter demonstrates compliance with the peak conducted power limits. If the transmitter complies with the conducted power limits based on the use of RMS averaging over a time interval, as permitted under paragraph (b)(3) of this section, the attenuation required under this paragraph shall be 30dB instead of 20dB. Attenuation below the general limits specified in §15.209(a) is not required.

Frequency (MHz)	Quasi-peak(μV/m)	Measurement distance(m)	Quasi-peak(dBμV/m)@distance 3m
0.009-0.490	2400/F(kHz)	300	128.5-93.8
0.490-1.705	24000/F(kHz)	30	73.8-63
1.705-30.0	30	30	69.5
30 ~ 88	100	3	40
88~216	150	3	43.5
216 ~ 960	200	3	46
Above 960	500	3	54

**NOTE:**

- (1) The emission limits for the ranges 9-90kHz and 110-490kHz are based on measurements employing a linear average detector.
- (2) The lower limit shall apply at the transition frequencies.
- (3) Above 18GHz test distance is 1m, so the Peak Limit= $74+20*\log(3/1)=83.54$  (dBμV/m).  
The Avg Limit= $54+20*\log(3/1)=63.54$  (dBμV/m).

### 5.2 TEST PROCEDURES

#### 1) Sequence of testing 9kHz to 30MHz

**Setup:**

- The equipment was set up to simulate a typical usage like described in the user manual or described by manufacturer.
- If the EUT is a tabletop system, a rotatable table with 0.8m height is used.
- If the EUT is a floor standing device, it is placed on the ground.
- Auxiliary equipment and cables were positioned to simulate normal operation conditions.
- The AC power port of the EUT (if available) is connected to a power outlet below the turntable.
- The measurement distance is 3meter.
- The EUT was set into operation.

**Pre measurement:**

- The turntable rotates from 0 ° to 360 °.
- The antenna height is 1.0 meter.
- At each turntable position the analyzer sweeps with peak detection to find the maximum of all emissions

**Final measurement:**

- Identified emissions during the pre measurement the software maximizes by rotating the turntable position (0 ° to 360 °) and by rotating the elevation axes (0 ° to 360 °).
- The final measurement will be done in the position (turntable and elevation) causing the highest emissions with QP detector.

--- The final levels, frequency, measuring time, bandwidth, turntable position, correction factor, margin to the limit and limit will be recorded. Also a plot with the graph of the pre measurement and the limit will be stored.

## 2) Sequence of testing 30MHz to 1GHz

### Setup:

--- The equipment was set up to simulate a typical usage like described in the user manual or described by manufacturer.

--- If the EUT is a tabletop system, a table with 0.8m height is used, which is placed on the ground plane.

--- If the EUT is a floor standing device, it is placed on the ground plane with insulation between both.

--- Auxiliary equipment and cables were positioned to simulate normal operation conditions

--- The AC power port of the EUT (if available) is connected to a power outlet below the turntable.

--- The measurement distance is 3 meter.

--- The EUT was set into operation.

### Pre measurement:

--- The turntable rotates from 0 ° to 360 °.

--- The antenna is polarized vertical and horizontal.

--- The antenna height changes from 1 to 4 meter.

--- At each turntable position, antenna polarization and height the analyzer sweeps three times in peak to find the maximum of all emissions.

### Final measurement:

--- The final measurement will be performed with minimum the six highest peaks.

--- According to the maximum antenna and turntable positions of pre measurement the software maximize the peaks by changing turntable rotates from 0 ° to 360 ° and antenna movement between 1 and 4 meter.

--- The final measurement will be done with QP detector with an EMI receiver.

--- The final levels, frequency, measuring time, bandwidth, antenna height, antenna polarization, turntable angle, correction factor, margin to the limit and limit will be recorded. Also a plot with the graph of the pre measurement with marked maximum final measurements and the limit will be stored.

## 3) Sequence of testing 1GHz to 18GHz

### Setup:

--- The equipment was set up to simulate a typical usage like described in the user manual or described by manufacturer.

--- If the EUT is a tabletop system, a rotatable table with 1.5m height is used.

--- If the EUT is a floor standing device, it is placed on the ground plane with insulation between both.

--- Auxiliary equipment and cables were positioned to simulate normal operation conditions

--- The AC power port of the EUT (if available) is connected to a power outlet below the turntable.

--- The measurement distance is 3 meter.

--- The EUT was set into operation.

### Pre measurement:

--- The turntable rotates from 0 ° to 360 °.

--- The antenna is polarized vertical and horizontal.

--- The antenna height scan range is 1 meter to 4 meter.

--- At each turntable position and antenna polarization the analyzer sweeps with peak detection to find the maximum of all emissions.

#### **Final measurement:**

--- The final measurement will be performed with minimum the six highest peaks.

--- According to the maximum antenna and turntable positions of pre measurement the software maximize the peaks by changing turntable rotates from 0 ° to 360 ° and antenna movement between 1 and 4 meter. This procedure is repeated for both antenna polarizations.

--- The final measurement will be done in the position (turntable, EUT-table and antenna polarization) causing the highest emissions with Peak and Average detector.

--- The final levels, frequency, measuring time, bandwidth, turntable position, EUT-table position, antenna polarization, correction factor, margin to the limit and limit will be recorded. Also a plot with the graph of the pre measurement with marked maximum final measurements and the limit will be stored.

#### **4) Sequence of testing above 18GHz**

##### **Setup:**

--- The equipment was set up to simulate a typical usage like described in the user manual or described by manufacturer.

--- If the EUT is a tabletop system, a rotatable table with 1.5 m height is used.

--- If the EUT is a floor standing device, it is placed on the ground plane with insulation between both.

--- Auxiliary equipment and cables were positioned to simulate normal operation conditions

--- The AC power port of the EUT (if available) is connected to a power outlet below the turntable.

--- The measurement distance is 1 meter.

--- The EUT was set into operation.

##### **Pre measurement:**

--- The antenna is moved spherical over the EUT in different polarisations of the antenna.

##### **Final measurement:**

--- The final measurement will be performed at the position and antenna orientation for all detected emissions that were found during the pre measurements with Peak and Average detector.

--- The final levels, frequency, measuring time, bandwidth, correction factor, margin to the limit and limit will be recorded. Also a plot with the graph of the premeasurement and the limit will be stored.

##### **NOTE:**

(a). The frequency from 9kHz to 150kHz, Set RBW=300Hz(for Peak & AVG), VBW=300Hz(for Peak & AVG). The frequency from 150kHz to 30MHz, Set RBW=9kHz, VBW=9kHz, (for QP Detector).

(b). The frequency from 30MHz to 1GHz, Set RBW=120kHz, VBW=300kHz, (for QP Detector).

(c). The frequency above 1GHz, for Peak detector: Set RBW=1MHz, VBW=3MHz.

(d). The frequency above 1GHz, for Avg detector: Set RBW=1MHz, if the EUT is configured to transmit with duty cycle  $\geq 98\%$ , set  $VBW \leq RBW/100$  (i.e., 10kHz) but not less than 10 Hz. If the EUT duty cycle is  $< 98\%$ , set  $VBW \geq 1/T$ , Where T is defined in section 2.9.

(e). For radiated measurement, pre-scanned in three orthogonal panels, X, Y, Z. The worst cases (X plane) were recorded in this report.

### 5.3 TEST SETUP

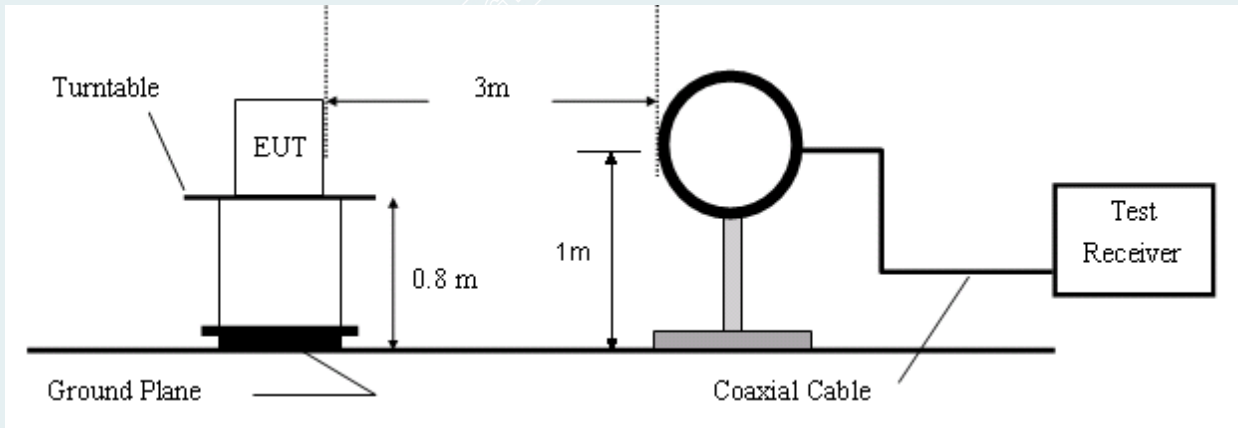

Figure 1. 9kHz to 30MHz radiated emissions test configuration

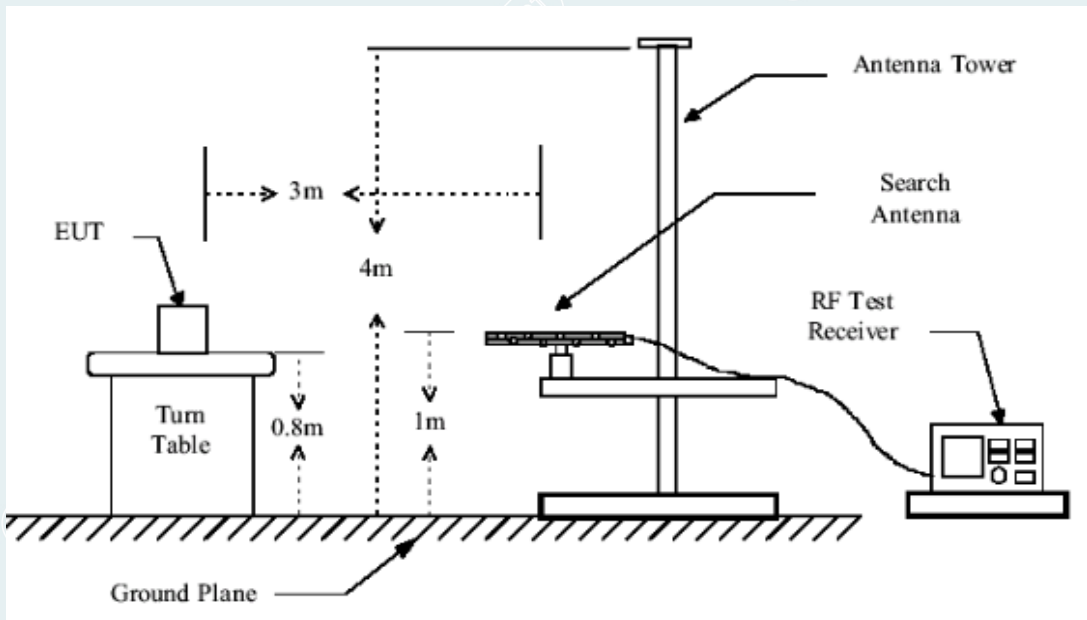

Figure 2. 30MHz to 1GHz radiated emissions test configuration

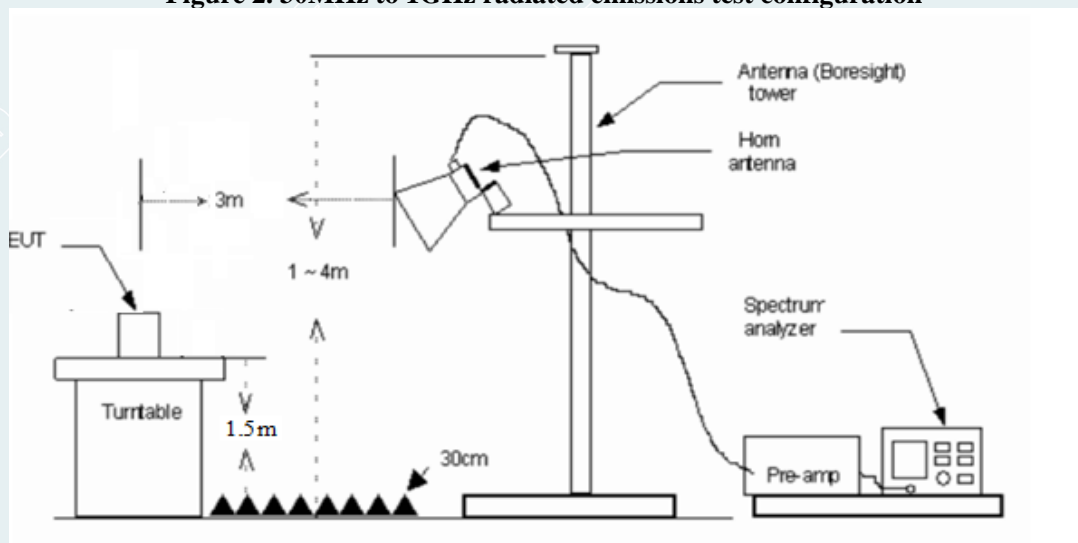

Figure 3. 1GHz to 18GHz radiated emissions test configuration

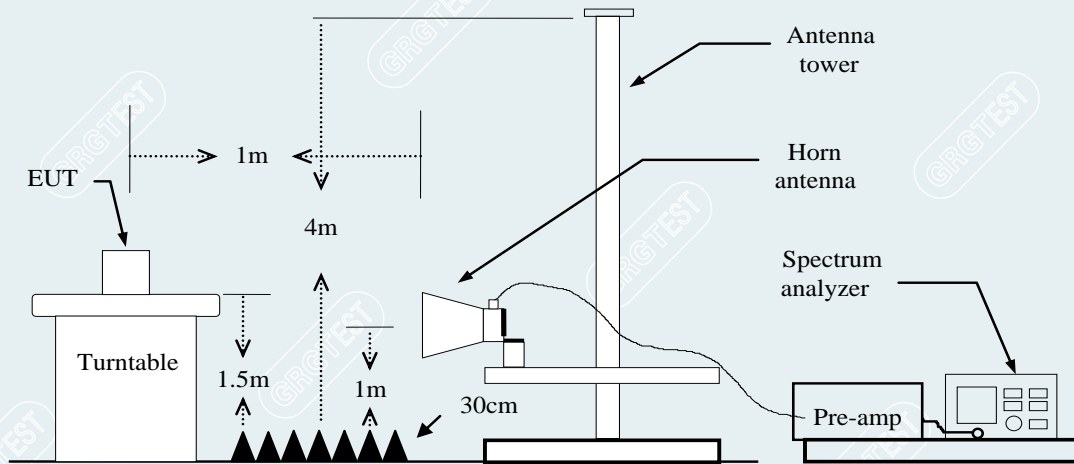

Figure 4. 18GHz to 26.5GHz radiated emissions test configuration

5.4 DATA SAMPLE

30MHz to 1GHz

No.	Frequency (MHz)	Reading (dBuV/m)	Correct Factor(dB/m)	Result (dBuV/m)	Limit (dBuV/m)	Margin (dB)	Remark	Pole
xxx	xxx	37.06	-15.48	21.58	40.00	-18.42	QP	Vertical

1GHz to 18GHz

No.	Frequency (MHz)	Reading (dBuV/m)	Correct Factor(dB/m)	Result (dBuV/m)	Limit (dBuV/m)	Margin (dB)	Remark	Pole
xxx	xxx	65.45	-11.12	54.33	74.00	-19.67	Peak	Vertical
xxx	xxx	63.00	-11.12	51.88	54.00	-2.12	AVG	Vertical

Above 18GHz

No.	Frequency (MHz)	Reading (dBuV/m)	Factor (dB)	Level (dBuV/m)	Limit (dBuV/m)	Margin (dB)	Remark	Pole
xxx	xxx	68.86	57.66	-11.20	83.54	25.88	peak	Vertical
xxx	xxx	68.89	-11.20	57.69	63.54	5.85	AVG	Vertical

- Frequency (MHz) = Emission frequency in MHz
- Ant.Pol. (H/V) = Antenna polarization
- Reading (dBuV) = Uncorrected Analyzer / Receiver reading
- Correction Factor (dB/m) = Antenna factor + Cable loss – Amplifier gain
- Result (dBuV/m) = Reading (dBuV) + Correction Factor (dB/m)
- Limit (dBuV/m) = Limit stated in standard
- Margin (dB) = Remark Result (dBuV/m) – Limit (dBuV/m)
- Peak = Peak Reading
- QP = Quasi-peak Reading
- AVG = Average Reading



5.5 TEST RESULTS

9kHz to 1GHz

<b>EUT Name</b>	Wireless earphones	<b>Model</b>	E505A
<b>Environmental Conditions</b>	23.1°C/42%RH	<b>Test Voltage</b>	DC 3.8V
<b>Test Mode</b>	TX/1Mbps (2402MHz)	<b>Polarity</b>	Vertical
<b>Tested By</b>	Tang Shenghui	<b>Tested Date</b>	2022/02/22

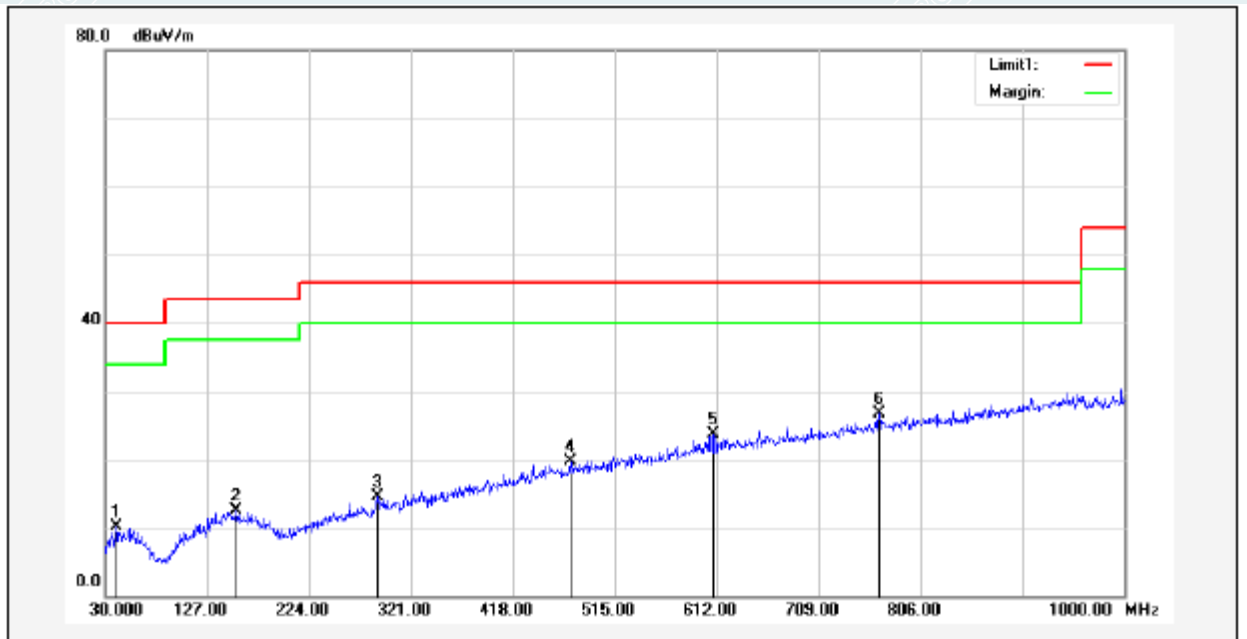

No.	Frequency (MHz)	Reading (dBuV)	Correction factor(dB/m)	Result (dBuV/m)	Limit (dBuV/m)	Over (dB)	Degree (deg.)	Height (cm)	Remark
1	40.6700	36.96	-26.87	10.09	40.00	-29.91	308	100	QP
2	154.1600	36.90	-24.44	12.46	43.50	-31.04	279	300	QP
3	288.9900	37.91	-23.50	14.41	46.00	-31.59	222	200	QP
4	472.3200	37.43	-17.80	19.63	46.00	-26.37	228	200	QP
5	609.0900	37.96	-14.31	23.65	46.00	-22.35	360	242	QP
6*	766.2300	38.08	-11.42	26.66	46.00	-19.34	285	300	QP

<b>EUT Name</b>	Wireless earphones	<b>Model</b>	E505A
<b>Environmental Conditions</b>	23.1°C/42%RH	<b>Test Voltage</b>	DC 3.8V
<b>Test Mode</b>	TX/1Mbps (2402MHz)	<b>Polarity</b>	Horizontal
<b>Tested By</b>	Tang Shenghui	<b>Tested Date</b>	2022/02/22

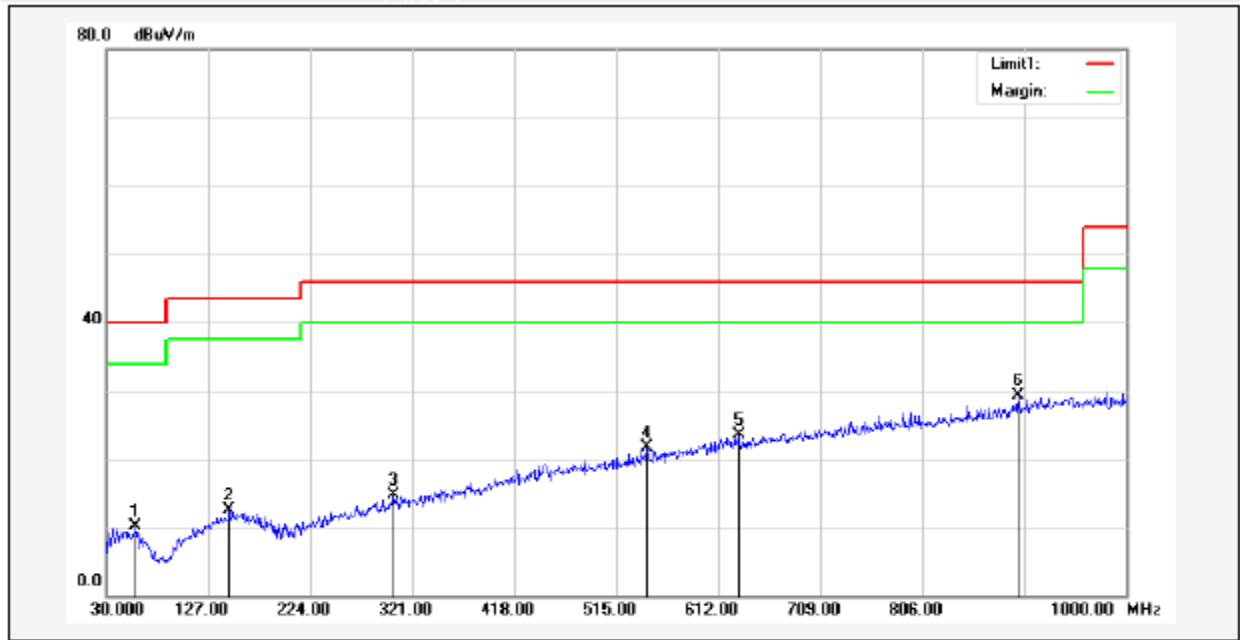

No.	Frequency (MHz)	Reading (dBuV)	Correction factor(dB/m)	Result (dBuV/m)	Limit (dBuV/m)	Over (dB)	Degree (deg.)	Height (cm)	Remark
1	58.1300	37.19	-27.13	10.06	40.00	-29.94	288	200	QP
2	147.3700	36.91	-24.50	12.41	43.50	-31.09	360	250	QP
3	303.5400	37.73	-23.00	14.73	46.00	-31.27	105	400	QP
4	544.1000	37.85	-16.17	21.68	46.00	-24.32	185	100	QP
5	631.4000	37.45	-13.97	23.48	46.00	-22.52	167	300	QP
6*	897.1800	38.72	-9.49	29.23	46.00	-16.77	142	300	QP

<b>EUT Name</b>	Wireless earphones	<b>Model</b>	E505A
<b>Environmental Conditions</b>	23.1°C/42%RH	<b>Test Voltage</b>	DC 3.8V
<b>Test Mode</b>	TX/1Mbps (2440MHz)	<b>Polarity</b>	Vertical
<b>Tested By</b>	Tang Shenghui	<b>Tested Date</b>	2022/02/22

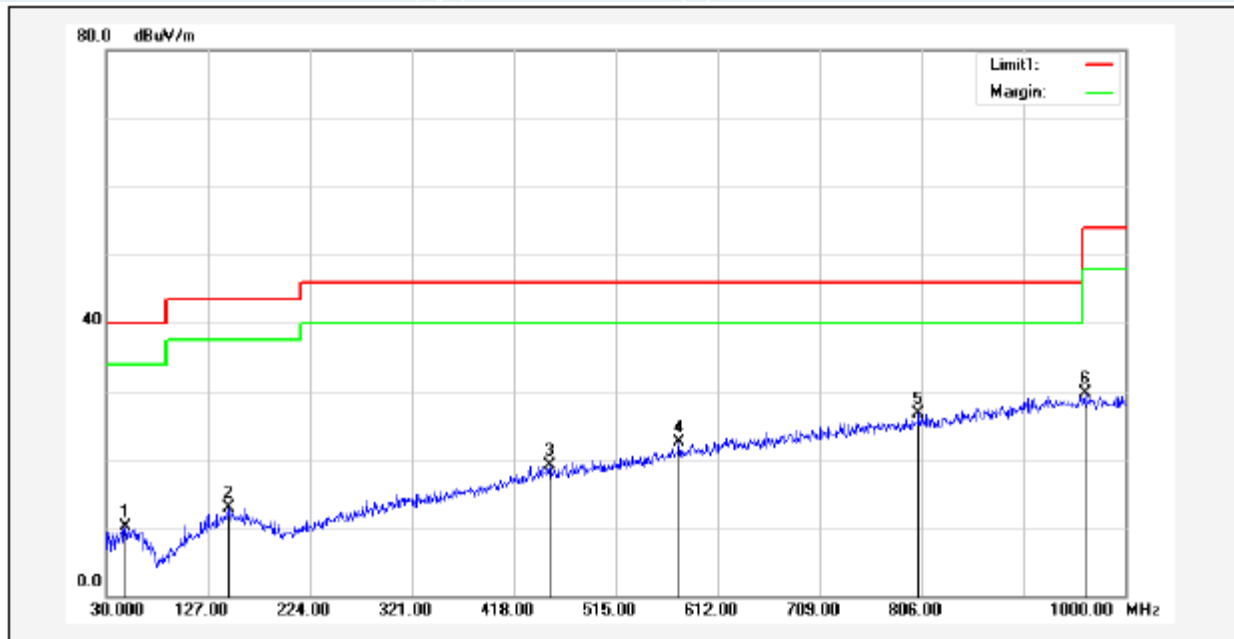

No.	Frequency (MHz)	Reading (dBuV)	Correction factor(dB/m)	Result (dBuV/m)	Limit (dBuV/m)	Over (dB)	Degree (deg.)	Height (cm)	Remark
1	48.4300	36.66	-26.55	10.11	40.00	-29.89	109	100	QP
2	146.4000	37.41	-24.54	12.87	43.50	-30.63	5	400	QP
3	451.9500	37.21	-18.14	19.07	46.00	-26.93	252	400	QP
4	575.1400	37.83	-15.23	22.60	46.00	-23.40	131	100	QP
5*	803.0900	37.51	-10.89	26.62	46.00	-19.38	245	200	QP
6	961.2000	38.28	-8.59	29.69	54.00	-24.31	147	400	QP

<b>EUT Name</b>	Wireless earphones	<b>Model</b>	E505A
<b>Environmental Conditions</b>	23.1°C/42%RH	<b>Test Voltage</b>	DC 3.8V
<b>Test Mode</b>	TX/1Mbps (2440MHz)	<b>Polarity</b>	Horizontal
<b>Tested By</b>	Tang Shenghui	<b>Tested Date</b>	2022/02/22

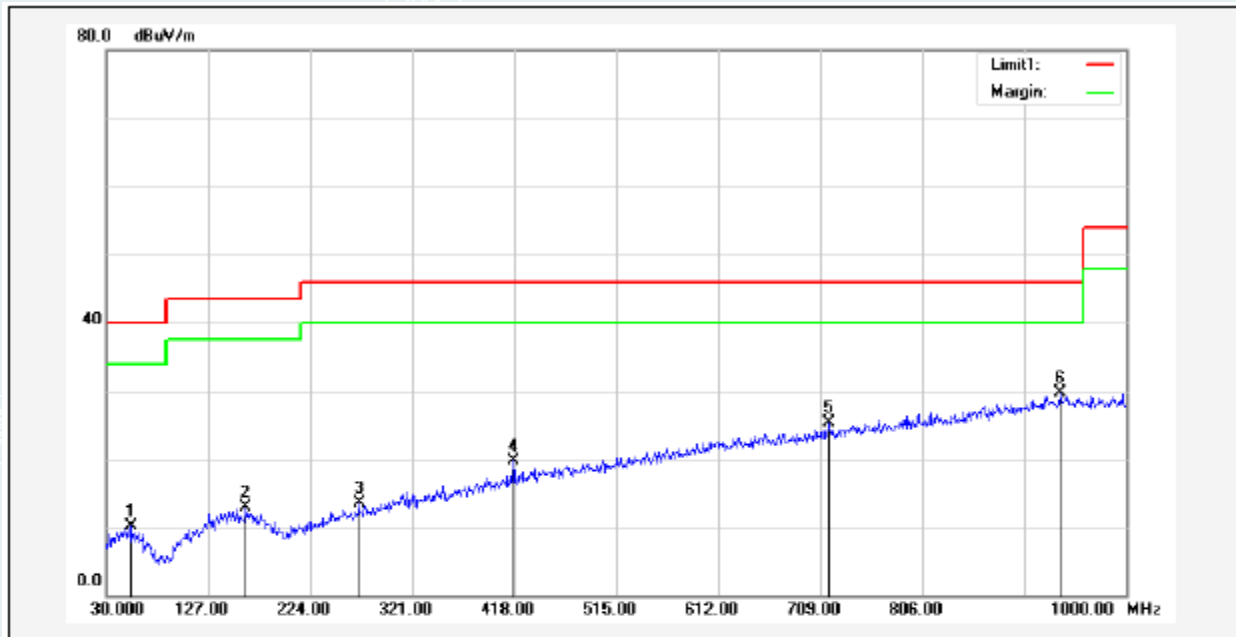

No.	Frequency (MHz)	Reading (dBuV)	Correction factor(dB/m)	Result (dBuV/m)	Limit (dBuV/m)	Over (dB)	Degree (deg.)	Height (cm)	Remark
1	53.2800	36.79	-26.74	10.05	40.00	-29.95	271	300	QP
2	162.8900	37.63	-24.64	12.99	43.50	-30.51	151	300	QP
3	270.5600	37.63	-24.18	13.45	46.00	-32.55	356	200	QP
4	417.0300	39.15	-19.35	19.80	46.00	-26.20	234	100	QP
5	717.7300	37.57	-12.35	25.22	46.00	-20.78	0	301	QP
6*	936.9500	38.54	-8.92	29.62	46.00	-16.38	264	400	QP

<b>EUT Name</b>	Wireless earphones	<b>Model</b>	E505A
<b>Environmental Conditions</b>	23.1°C/42%RH	<b>Test Voltage</b>	DC 3.8V
<b>Test Mode</b>	TX/1Mbps (2480MHz)	<b>Polarity</b>	Vertical
<b>Tested By</b>	Tang Shenghui	<b>Tested Date</b>	2022/02/22

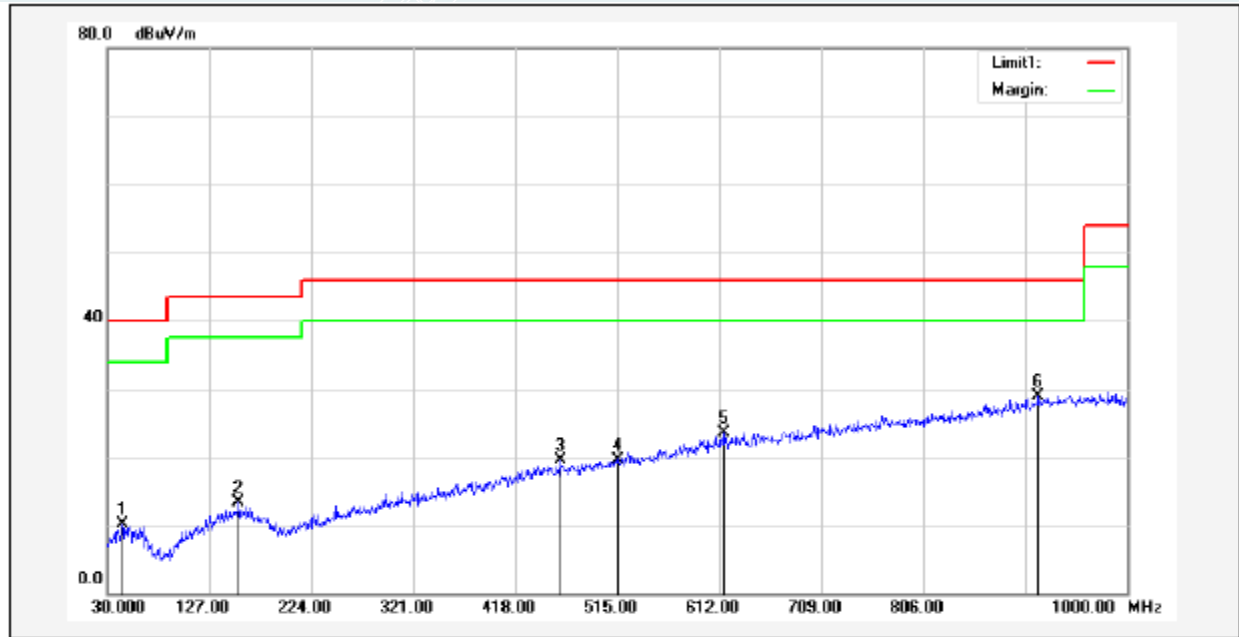

No.	Frequency (MHz)	Reading (dBuV)	Correction factor(dB/m)	Result (dBuV/m)	Limit (dBuV/m)	Over (dB)	Degree (deg.)	Height (cm)	Remark
1	44.5500	36.74	-26.71	10.03	40.00	-29.97	360	284	QP
2	155.1300	37.69	-24.45	13.24	43.50	-30.26	360	298	QP
3	460.6800	37.43	-17.99	19.44	46.00	-26.56	358	400	QP
4	515.0000	36.52	-16.92	19.60	46.00	-26.40	0	158	QP
5	616.8500	37.67	-14.19	23.48	46.00	-22.52	342	100	QP
6*	915.6100	38.19	-9.22	28.97	46.00	-17.03	358	200	QP

<b>EUT Name</b>	Wireless earphones	<b>Model</b>	E505A
<b>Environmental Conditions</b>	23.1 °C/42%RH	<b>Test Voltage</b>	DC 3.8V
<b>Test Mode</b>	TX/1Mbps (2480MHz)	<b>Polarity</b>	Horizontal
<b>Tested By</b>	Tang Shenghui	<b>Tested Date</b>	2022/02/22

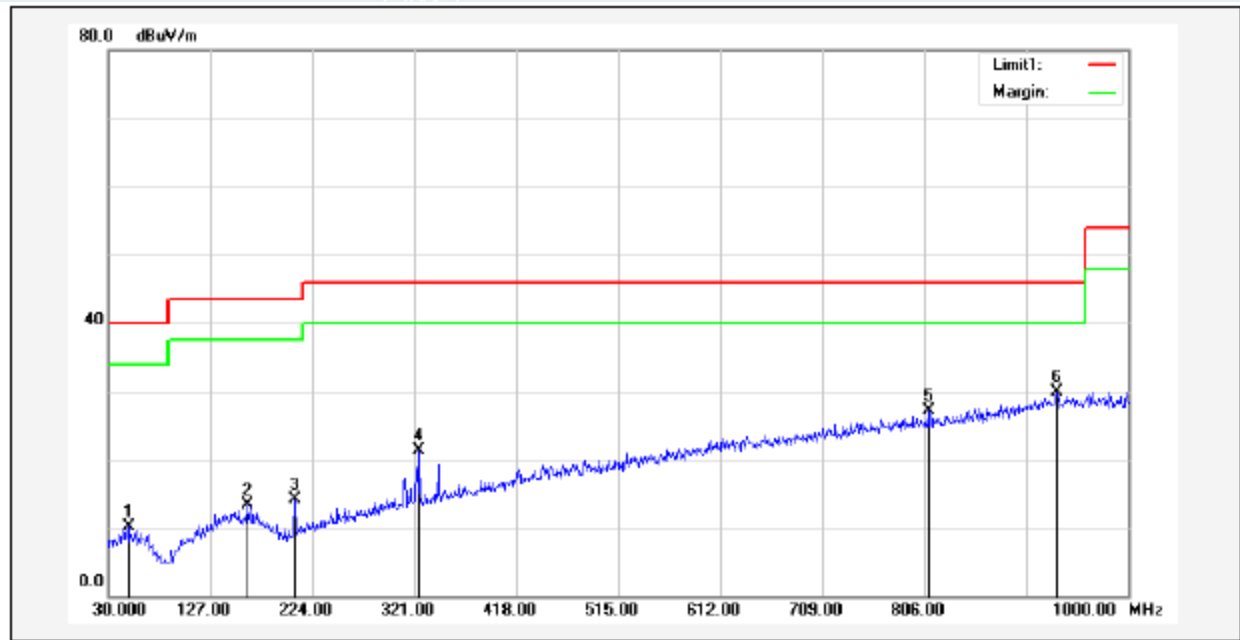

No.	Frequency (MHz)	Reading (dBuV)	Correction factor(dB/m)	Result (dBuV/m)	Limit (dBuV/m)	Over (dB)	Degree (deg.)	Height (cm)	Remark
1	49.4000	36.64	-26.50	10.14	40.00	-29.86	360	205	QP
2	161.9200	37.90	-24.61	13.29	43.50	-30.21	109	100	QP
3	207.5100	41.13	-26.97	14.16	43.50	-29.34	246	100	QP
4	325.8500	43.84	-22.45	21.39	46.00	-24.61	204	100	QP
5	809.8800	37.82	-10.79	27.03	46.00	-18.97	170	300	QP
6*	932.1000	38.81	-8.99	29.82	46.00	-16.18	360	291	QP

**Remark:**

- 1 No emission found between lowest internal used/generated frequency to 30MHz.
- 2 Data of measurement within this frequency range in the table above the reading of PK detector are more 6dB than QP limit, therefore it's unnecessary to performed QP scan.
- 3 The IF bandwidth of Receiver between 30MHz to 1GHz was 120kHz.

**Above 1GHz:**

According to C63.10, if the peak (or quasi-peak) measured value complies with the average limit, it is unnecessary to perform an average measurement, so AV emission value did not show in below table if the peak value complies with average limit.

Mode: TX/1Mbps  
 Lowest Frequenc (2402MHz)  
 Environment: 25°C/60%RH  
 Tested By: Lu Qiang

Date: 2022/02/23  
 Voltage: DC 3.8V  
 /

Suspected Data List									
NO.	Freq. [MHz]	Reading [dBµV/m]	Level [dBµV/m]	Factor [dB]	Limit [dBµV/m]	Margin [dB]	Height [cm]	Angle [°]	Polarity
1	1038.2548	57.72	32.63	-25.09	74.00	41.37	200	233	Horizontal
2	1456.0570	56.89	33.76	-23.13	74.00	40.24	100	185	Horizontal
3	1763.0954	59.45	37.11	-22.34	74.00	36.89	200	157	Horizontal
4	3603.8255	55.68	41.38	-14.30	74.00	32.62	100	25	Horizontal
5	4803.9755	55.64	45.86	-9.78	74.00	28.14	200	203	Horizontal
6	7232.4041	48.78	45.29	-3.49	74.00	28.71	100	243	Horizontal

Suspected Data List									
NO.	Freq. [MHz]	Reading [dBµV/m]	Level [dBµV/m]	Factor [dB]	Limit [dBµV/m]	Margin [dB]	Height [cm]	Angle [°]	Polarity
1	1000.0000	57.57	32.41	-25.16	74.00	41.59	200	286	Vertical
2	1746.3433	59.78	37.35	-22.43	74.00	36.65	200	163	Vertical
3	3000.0000	54.68	38.07	-16.61	74.00	35.93	200	74	Vertical
4	3603.8255	54.06	39.76	-14.30	74.00	34.24	100	292	Vertical
5	4749.5937	52.20	42.75	-9.45	74.00	31.25	100	359	Vertical
6	7193.0241	49.02	45.88	-3.14	74.00	28.12	200	230	Vertical

----- The following blanks -----

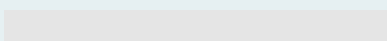

Mode: TX/1Mbps  
 Middle Frequenc (2440MHz)  
 Environment: 25°C/60%RH  
 Tested By: Lu Qiang

Date: 2022/02/23  
 Voltage: DC 3.8V

Suspected Data List									
NO.	Freq. [MHz]	Reading [dBμV/m]	Level [dBμV/m]	Factor [dB]	Limit [dBμV/m]	Margin [dB]	Height [cm]	Angle [°]	Polarity
1	1217.2772	66.50	42.10	-24.40	74.00	31.90	100	225	Horizontal
2	1796.0995	65.01	42.92	-22.09	74.00	31.08	100	280	Horizontal
3	2795.9745	65.07	46.60	-18.47	74.00	27.40	100	266	Horizontal
4	4700.8376	52.39	42.77	-9.62	74.00	31.23	100	196	Horizontal
5	7209.9012	50.21	46.98	-3.23	74.00	27.02	200	352	Horizontal
6	9927.1159	46.24	48.05	1.81	74.00	25.95	100	13	Horizontal

Suspected Data List									
NO.	Freq. [MHz]	Reading [dBμV/m]	Level [dBμV/m]	Factor [dB]	Limit [dBμV/m]	Margin [dB]	Height [cm]	Angle [°]	Polarity
1	1061.5077	65.81	40.78	-25.03	74.00	33.22	200	334	Vertical
2	1399.0499	63.46	39.97	-23.49	74.00	34.03	200	360	Vertical
3	1794.5993	66.63	44.53	-22.10	74.00	29.47	100	308	Vertical
4	2593.4492	63.89	44.65	-19.24	74.00	29.35	200	355	Vertical
5	2991.9990	63.01	45.31	-17.70	74.00	28.69	100	315	Vertical
6	4785.2232	51.95	42.25	-9.70	74.00	31.75	100	129	Vertical

----- The following blanks -----



Mode: TX/1Mbps  
 Highest Frequency (2480MHz)  
 Environment: 25°C/60%RH  
 Tested By: Lu Qiang

Date: 2022/02/23  
 Voltage: DC 3.8V

Suspected Data List									
NO.	Freq. [MHz]	Reading [dB $\mu$ V/m]	Level [dB $\mu$ V/m]	Factor [dB]	Limit [dB $\mu$ V/m]	Margin [dB]	Height [cm]	Angle [°]	Polarity
1	1081.2602	63.77	38.82	-24.95	74.00	35.18	100	89	Horizontal
2	1359.5449	67.46	43.77	-23.69	74.00	30.23	200	184	Horizontal
3	2059.3824	64.72	43.26	-21.46	74.00	30.74	100	265	Horizontal
4	2593.4492	64.47	45.23	-19.24	74.00	28.77	100	259	Horizontal
5	4959.6200	53.05	43.04	-10.01	74.00	30.96	100	359	Horizontal
6	10817.8522	45.88	49.74	3.86	74.00	24.26	200	153	Horizontal

Suspected Data List									
NO.	Freq. [MHz]	Reading [dB $\mu$ V/m]	Level [dB $\mu$ V/m]	Factor [dB]	Limit [dB $\mu$ V/m]	Margin [dB]	Height [cm]	Angle [°]	Polarity
1	1118.2648	72.58	47.81	-24.77	74.00	26.19	200	95	Vertical
2	1437.0546	67.01	43.76	-23.25	74.00	30.24	100	273	Vertical
3	1729.0911	67.47	45.06	-22.41	74.00	28.94	100	280	Vertical
4	2987.7485	65.90	48.18	-17.72	74.00	25.82	100	314	Vertical
5	4792.7241	53.08	43.33	-9.75	74.00	30.67	100	94	Vertical
6	6000.3750	53.10	45.61	-7.49	74.00	28.39	100	148	Vertical

**Remark:**

- 1 Measuring frequencies from 1 GHz to the 10th harmonic of highest fundamental frequency.
- 2 The amplitude of 18GHz to 26.5GHz spurious emission that is attenuated by more than 20dB below the permissible limit has no need to be reported.
- 3 Radiated emissions measured in frequency above 1000MHz were made with an instrument using peak/average detector mode.
- 4 Average test would be performed if the peak result were greater than the average limit or as required by the applicant.
- 5 Measurements above show only up to 6 maximum emissions noted, or would be lesser, with "N/A" remark, if no specific emissions from the EUT are recorded (ie: margin>20dB from the applicable limit) and considered that's already beyond the background noise floor.

**6. 6dB BANDWIDTH**

**6.1 LIMITS**

Systems using digital modulation techniques may operate in the 902–928 MHz, 2400–2483.5 MHz, and 5725–5850 MHz bands. The minimum 6 dB bandwidth shall be at least 500 kHz.

**6.2 TEST PROCEDURES**

- 1) Remove the antenna from the EUT, and then connect a low loss RF cable from antenna port to the spectrum analyzer.
- 2) Set resolution bandwidth (RBW) = 100kHz. Set the video bandwidth (VBW)  $\geq 3 \times$  RBW. Detector = Peak. Trace mode = max hold. Sweep = auto couple. Allow the trace to stabilize, record 6dB bandwidth value.
- 3) Repeat above procedures until all frequencies measured were complete.

**6.3 TEST SETUP**

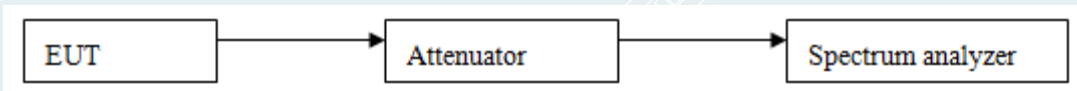

**6.4 TEST RESULTS**

Environment: 23.1°C/53%RH  
 Tested By: Lu Wei

Voltage: DC 3.8V  
 Date: 2022/02/17

Channel	Frequency (MHz)	Bandwidth (kHz)	Limit (kHz)	Test Result
Lowest	2402	660	≥500	PASS
Middle	2440	668		PASS
Highest	2480	664		PASS

Lowest Frequency (2402MHz)



Middle Frequency (2440 MHz)

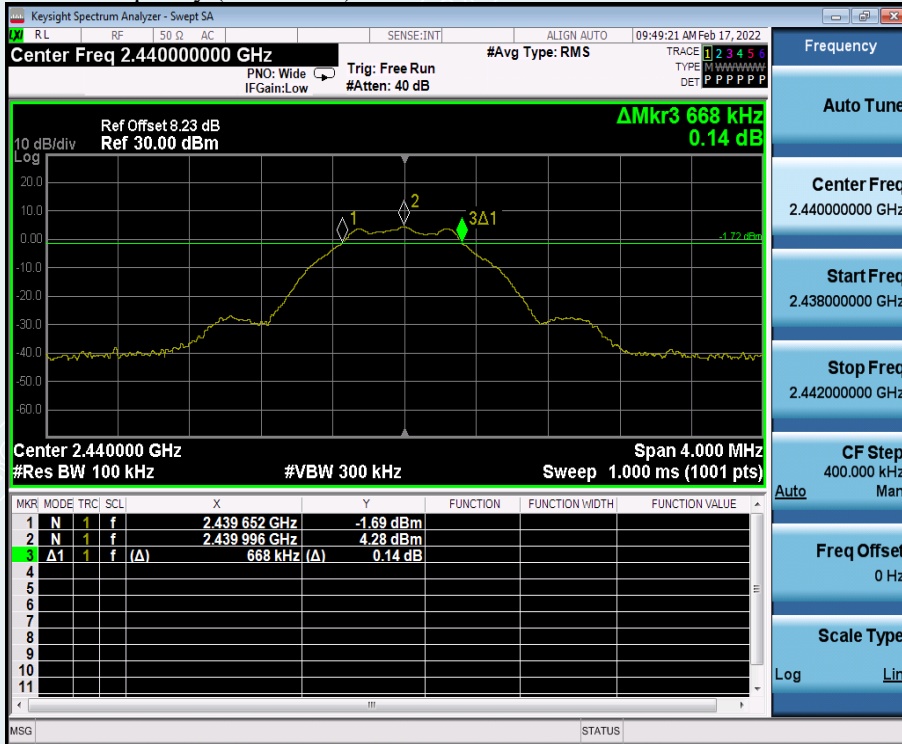

Highest Frequency (2480MHz)

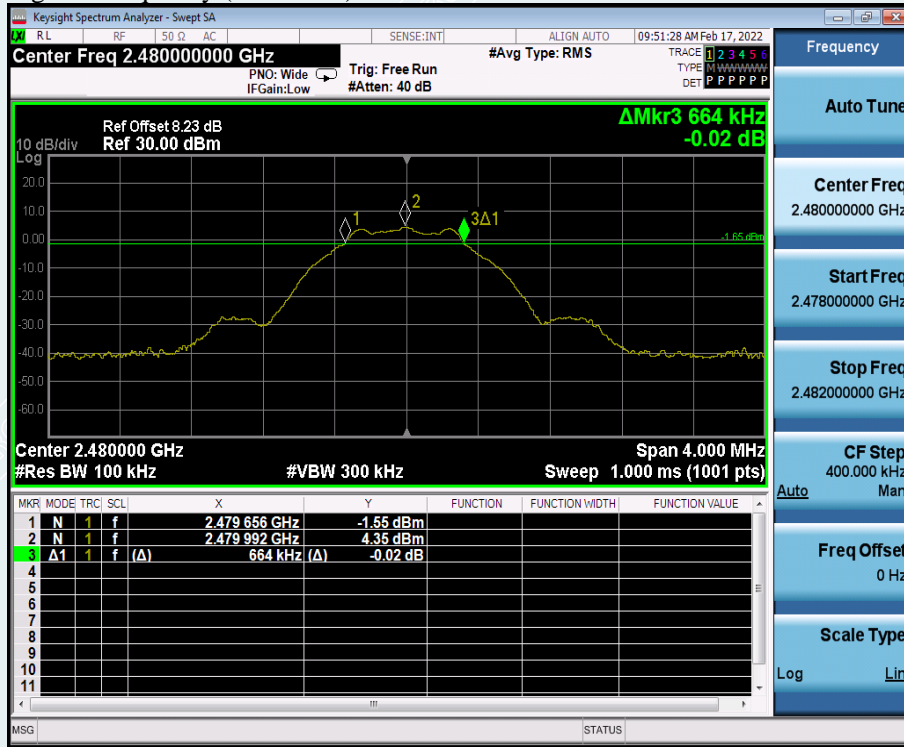

----- The following blanks -----

**7. MAXIMUM PEAK OUTPUT POWER**

**7.1 LIMITS**

The maximum Peak output power measurement is 1W

**7.2 TEST PROCEDURES**

- 1) RF output of EUT was connected to the broadband peak RF power meter by RF cable and attenuator. The path loss was compensated to the results for each measurement.
- 2) Set to the maximum power setting and enable the EUT transmit continuously.
- 3) Measure the conducted output power and record the results in the test report.

**7.3 TEST SETUP**

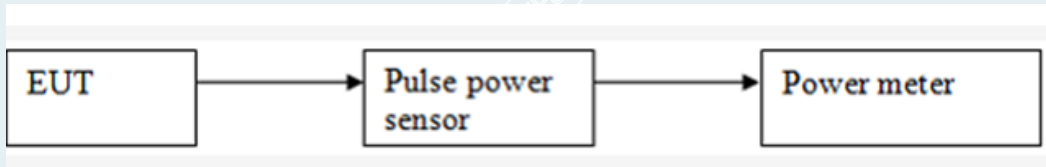

**7.4 TEST RESULTS**

Environment: 23.4°C/52%RH  
 Tested By: Lu Wei

Voltage: DC 3.8V  
 Date: 2022/02/16

Channel	Frequency (MHz)	Measured Channel Power (dBm)	Limit	Peak/Average	Result
Lowest	2402	4.45	1W (30dBm)	Peak	Pass
Middle	2440	4.76			Pass
Highest	2480	4.97			Pass

**8. POWER SPECTRAL DENSITY**

**8.1 LIMITS**

For digitally modulated systems, the power spectral density conducted from the intentional radiator to the antenna shall not be greater than 8 dBm in any 3 kHz band during any time interval of continuous transmission. This power spectral density shall be determined in accordance with the provisions of paragraph (b) of this section. The same method of determining the conducted output power shall be used to determine the power spectral density.

**8.2 TEST PROCEDURES**

- 1) Remove the antenna from the EUT, and then connect a low loss RF cable from antenna port to the spectrum analyzer.
- 2) Position the EUT was set without connection to measurement instrument. Turn on the EUT and connect its antenna terminal to measurement instrument via a low loss cable. Then set it to any one measured frequency within its operating range, and make sure the instrument is operated in its linear range.
- 3) Set the analyzer span to 1.5 times the DTS bandwidth. Set the RBW to  $3\text{ kHz} \leq \text{RBW} \leq 100\text{ kHz}$ . Set the VBW  $\geq [3 \times \text{RBW}]$ . Detector = peak. Sweep time = auto couple. Trace mode = max hold. Allow trace to fully stabilize. Use the peak marker function to determine the maximum amplitude level within the RBW. If measured value exceeds requirement, then reduce RBW (but no less than 3 kHz) and repeat.
- 4) Repeat above procedures until all frequencies measured were complete.

**8.3 TEST SETUP**



**8.4 TEST RESULTS**

Environment: 23.1°C/53%RH  
 Tested By: Lu Wei

Voltage: DC 3.8V  
 Date: 2022/02/17

Channel	Frequency (MHz)	PSD (dBm/3kHz)	Limit (dBm/3kHz)	Test Result
Lowest	2402	-4.02	8.00	PASS
Middle	2440	-3.85		PASS
Highest	2480	-3.77		PASS

### Lowest Frequency (2402MHz)



### Middle Frequency (2440 MHz)



### Highest Frequency (2480MHz)



----- The following blanks -----



## 9. CONDUCTED BAND EDGES AND SPURIOUS EMISSIONS

### 9.1 LIMITS

In any 100 kHz bandwidth outside the frequency band in which the spread spectrum or digitally modulated intentional radiator is operating, the radio frequency power that is produced by the intentional radiator shall be at least 20 dB below that in the 100 kHz bandwidth within the band that contains the highest level of the desired power, based on either an RF conducted or a radiated measurement, provided the transmitter demonstrates compliance with the peak conducted power limits. If the transmitter complies with the conducted power limits based on the use of RMS averaging over a time interval, as permitted under paragraph (b)(3) of this section, the attenuation required under this paragraph shall be 30 dB instead of 20 dB.

### 9.2 TEST PROCEDURES

Test procedures follow KDB 558074 D01 DTS Measurement Guidance v05r02.

Remove the antenna from the EUT and then connect a low attenuation cable from the antenna port to the spectrum.

- 1) Remove the antenna from the EUT and then connect a low attenuation cable from the antenna port to the spectrum.
- 2) Set the spectrum analyzer: RBW =100kHz; VBW =300kHz, Frequency range = 30MHz to 26.5GHz; Sweep = auto; Detector Function = Peak. Trace = Max, hold.
- 3) Measure and record the results in the test report.
- 4) The RF fundamental frequency should be excluded against the limit line in the operating frequency band.

### 9.3 TEST SETUP



### 9.4 TEST RESULTS

Environment: 23.1°C/53%RH  
Tested By: Lu Wei

Voltage: DC 3.8V  
Date: 2022/02/17

Lowest Frequency (2402MHz)  
2.30GHz-2.405GHz

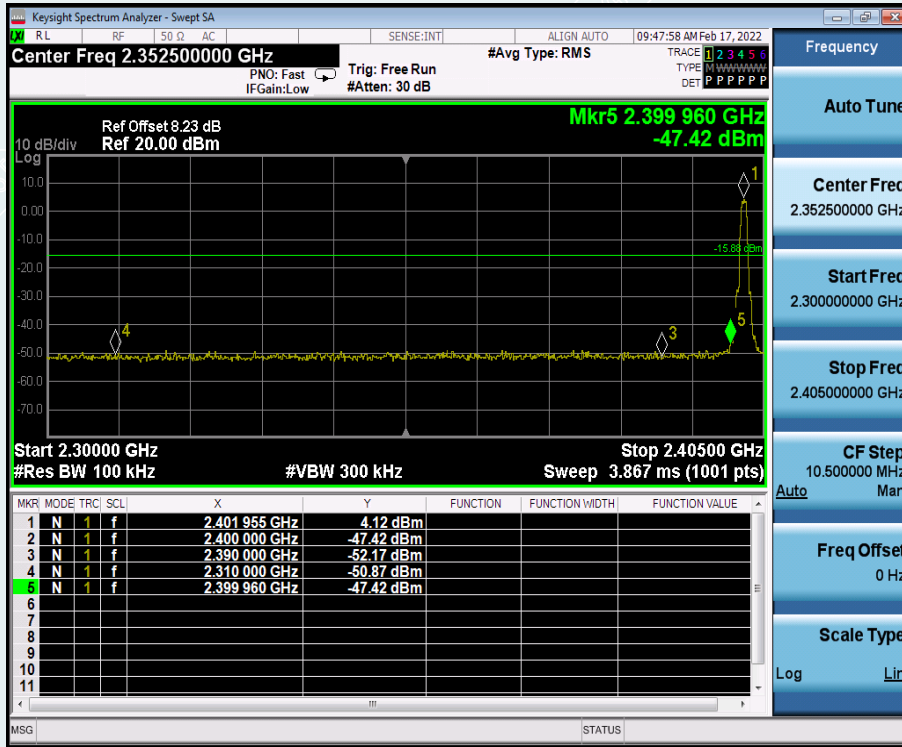

----- The following blanks -----

Highest Frequency (2480MHz)  
2.47GHz-2.55GHz

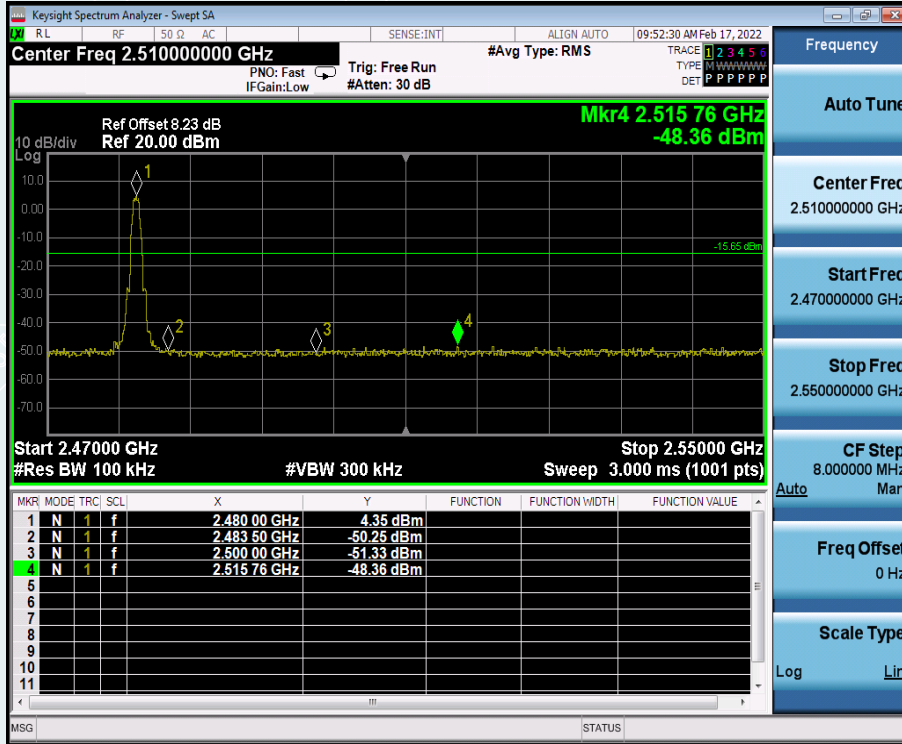

Lowest Frequency (2402MHz)



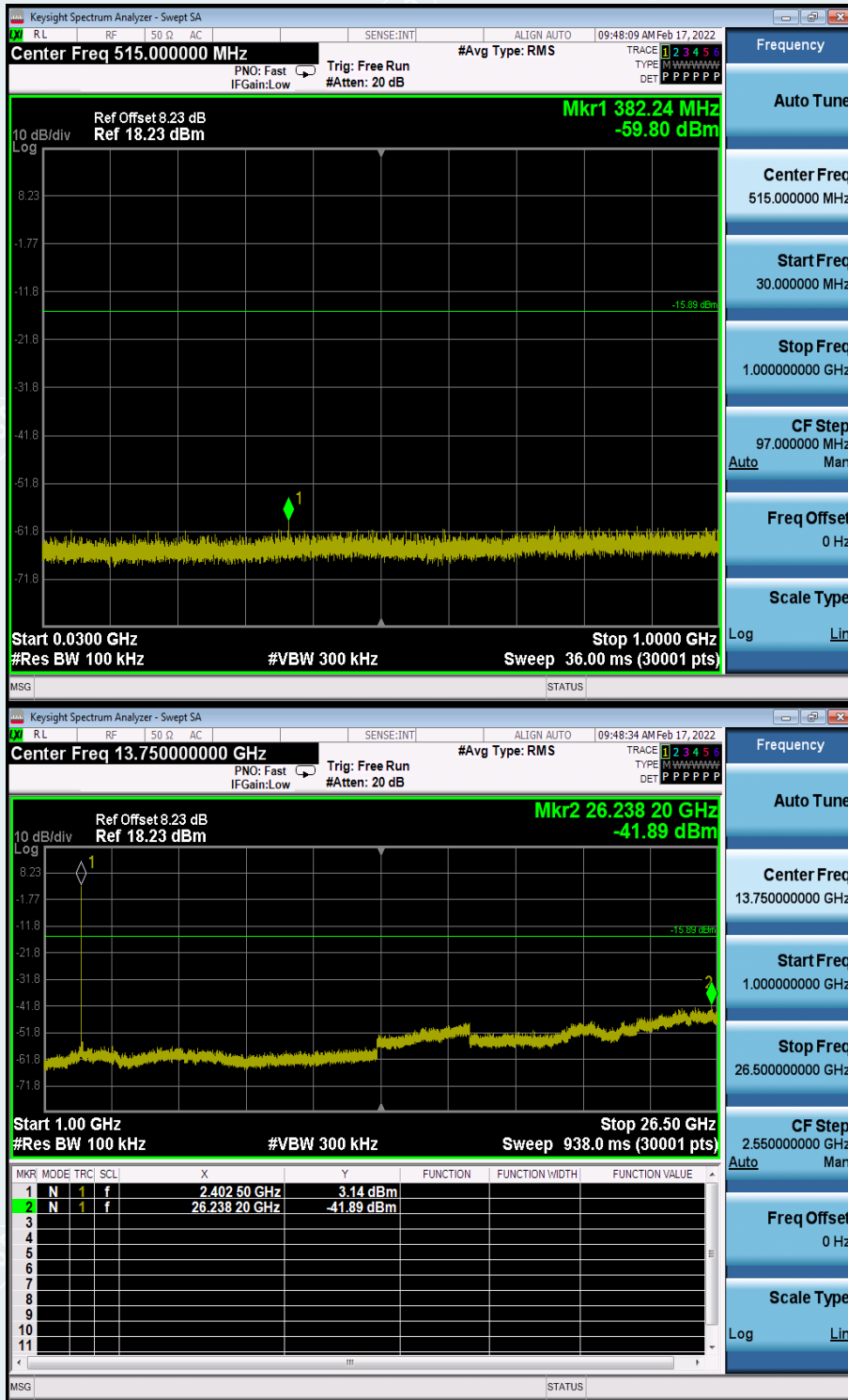

Middle Frequency (2440MHz)



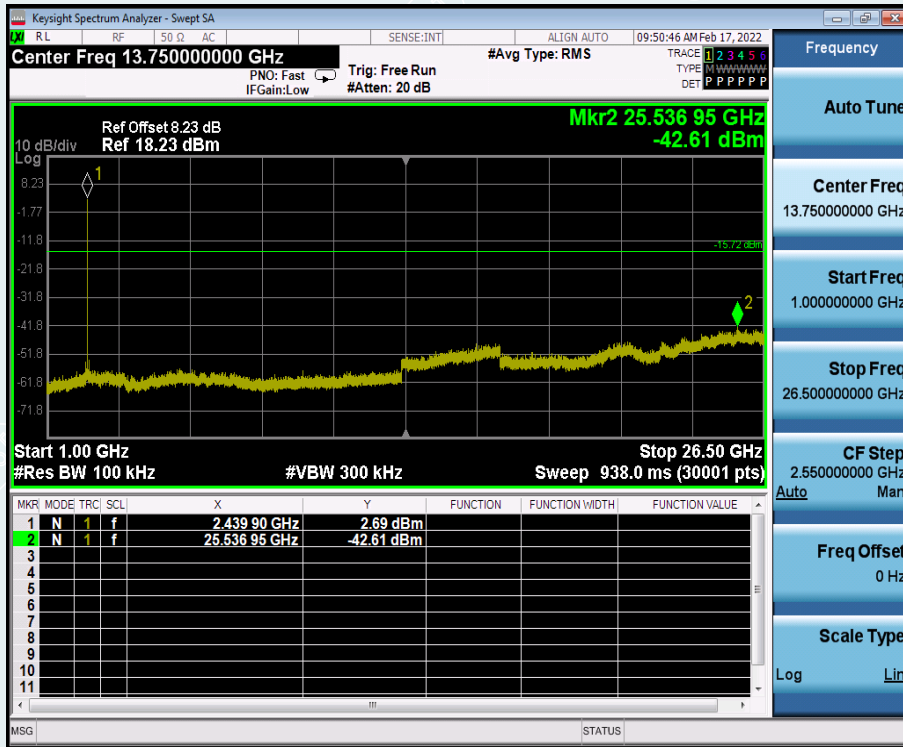

----- The following blanks -----

Highest Frequency (2480MHz)



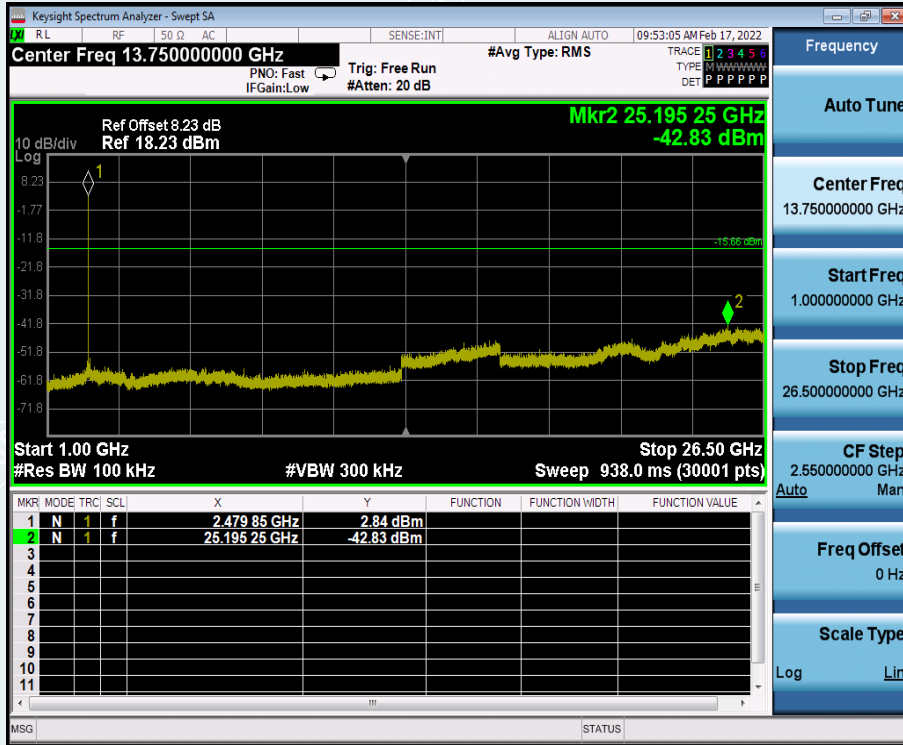

----- The following blanks -----



**10. RESTRICTED BANDS OF OPERATION**

**10.1 LIMITS**

Section 15.247(d) In addition, Radiated emissions which fall in the restricted bands, as defined in §15.205(a), must also comply with the radiated emission limits specified in §15.209(a) (see §15.205(c)).

MHz	MHz	MHz	GHz
0.090 - 0.110	16.42 - 16.423	399.9 - 410	4.5 - 5.15
<sup>1</sup> 0.495 - 0.505	16.69475 - 16.69525	608 - 614	5.35 - 5.46
2.1735 - 2.1905	16.80425 - 16.80475	960 - 1240	7.25 - 7.75
4.125 - 4.128	25.5 - 25.67	1300 - 1427	8.025 - 8.5
4.17725 - 4.17775	37.5 - 38.25	1435 - 1626.5	9.0 - 9.2
4.20725 - 4.20775	73 - 74.6	1645.5 - 1646.5	9.3 - 9.5
6.215 - 6.218	74.8 - 75.2	1660 - 1710	10.6 - 12.7
6.26775 - 6.26825	108 - 121.94	1718.8 - 1722.2	13.25 - 13.4
6.31175 - 6.31225	123 - 138	2200 - 2300	14.47 - 14.5
8.291 - 8.294	149.9 - 150.05	2310 - 2390	15.35 - 16.2
8.362 - 8.366	156.52475 - 156.52525	2483.5 - 2500	17.7 - 21.4
8.37625 - 8.38675	156.7 - 156.9	2655 - 2900	22.01 - 23.12
8.41425 - 8.41475	162.0125 - 167.17	3260 - 3267	23.6 - 24.0
12.29 - 12.293	167.72 - 173.2	3332 - 3339	31.2 - 31.8
12.51975 - 12.52025	240 - 285	3345.8 - 3358	36.43 - 36.5
12.57675 - 12.57725	322 - 335.4	3600 - 4400	
13.36 - 13.41			

Frequency (MHz)	Quasi-peak(μV/m)	Measurement distance(m)	Quasi-peak(dBμV/m)@distance 3m
0.009-0.490	2400/F(kHz)	300	128.5-93.8
0.490-1.705	24000/F(kHz)	30	73.8-63
1.705-30.0	30	30	69.5
30 ~ 88	100	3	40
88~216	150	3	43.5
216 ~ 960	200	3	46
Above 960	500	3	54

## 10.2 TEST PROCEDURES

Test procedures follow KDB 558074 D01 DTS Meas Guidance v05r02.

- 1) The EUT is placed on a turntable, which is 1.5m above the ground plane.
- 2) The turntable shall be rotated for 360 degrees to determine the position of maximum emission level.
- 3) EUT is set 3m away from the receiving antenna, which is varied from 1m to 4m to find out the highest emission.
- 4) Set the spectrum analyzer in the following setting in order to capture the lower and upper band-edges of the emission:
  - a) PEAK: RBW=1MHz / VBW=1MHz / Sweep=AUTO
  - b) AVERAGE: RBW=1MHz / VBW=1/T / Sweep=AUTO
- 5) Repeat the procedures until all the PEAK and AVERAGE versus polarization are measured.

**Note:** For radiated measurement, pre-scanned in three orthogonal panels, X, Y, Z. The worst cases (X plane) were recorded in this report.

## 10.3 TEST SETUP

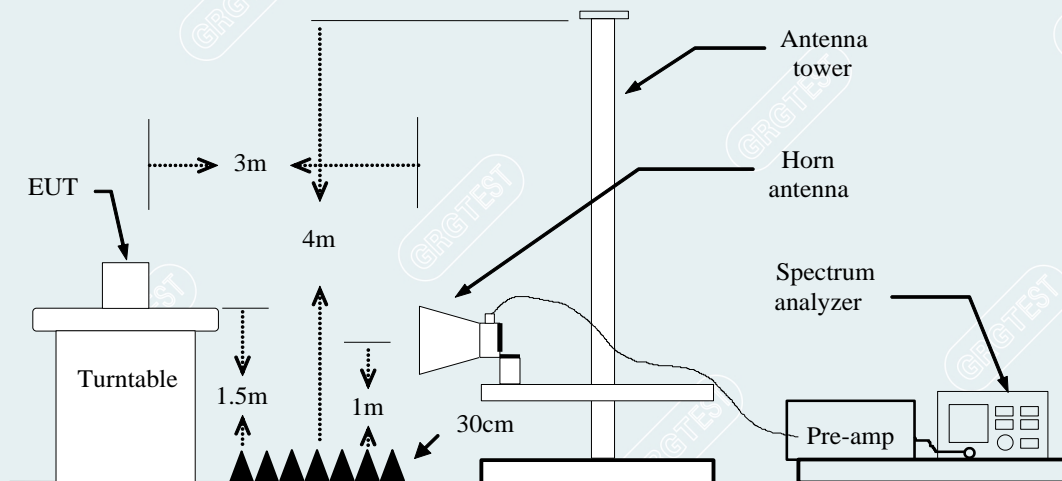

10.4 TEST RESULTS

Equipment:	Wireless earphones	Test Date	2022/02/25
Model No.:	E505A	Test Engineer:	Lu Qiang
Test Voltage:	DC 3.8V	/	/

Lowest Frequency  
 Frequency 2402MHz  
 Detector mode: Peak

Polarity: Horizontal

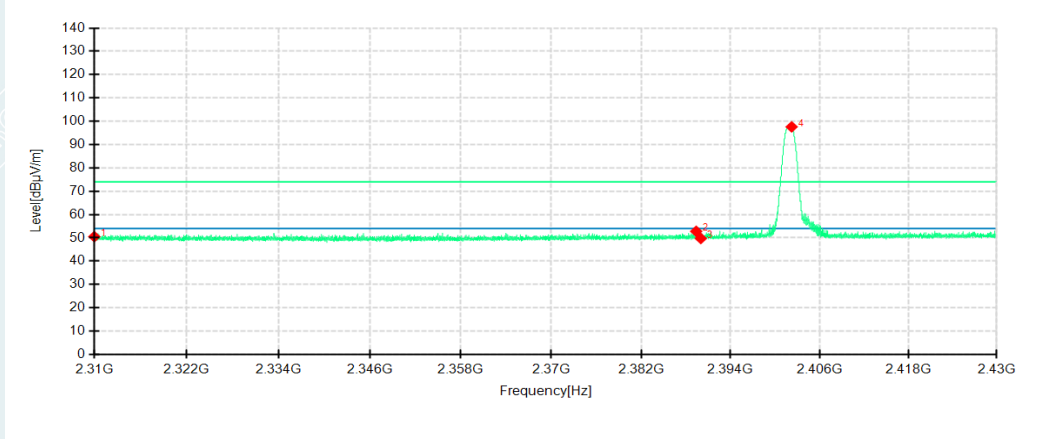

Detector mode: Peak

Polarity: Vertical

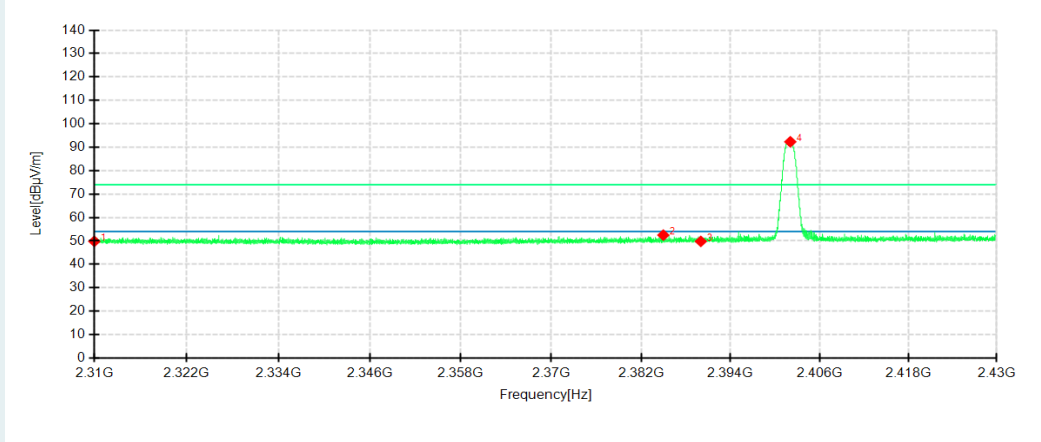

No.	Frequency MHz	Reading dB $\mu$ V/m	Level dB $\mu$ V/m	Factor dB	Limit dBuV/m	Margin dB	Height cm	Angle $^{\circ}$	Pole	Remark
1	2310.0000	47.03	50.51	3.48	74.00	23.49	200	47	Horizontal	/
2	2389.3800	48.99	52.79	3.80	74.00	21.21	100	142	Horizontal	/
3	2390.0000	45.93	49.74	3.81	74.00	24.26	200	218	Horizontal	/
4	2402.2200	93.60	97.59	3.99	74.00	-23.59	100	299	Horizontal	No limit
1	2310.0000	46.33	49.81	3.48	74.00	24.19	100	204	Vertical	/
2	2384.9760	48.75	52.47	3.72	74.00	21.53	200	142	Vertical	/
3	2390.0000	45.98	49.79	3.81	74.00	24.21	200	300	Vertical	/
4	2402.0400	88.34	92.33	3.99	74.00	-18.33	100	218	Vertical	No limit

Lowest Frequency  
 Frequency 2402MHz  
 Detector mode: Average

Polarity: Horizontal

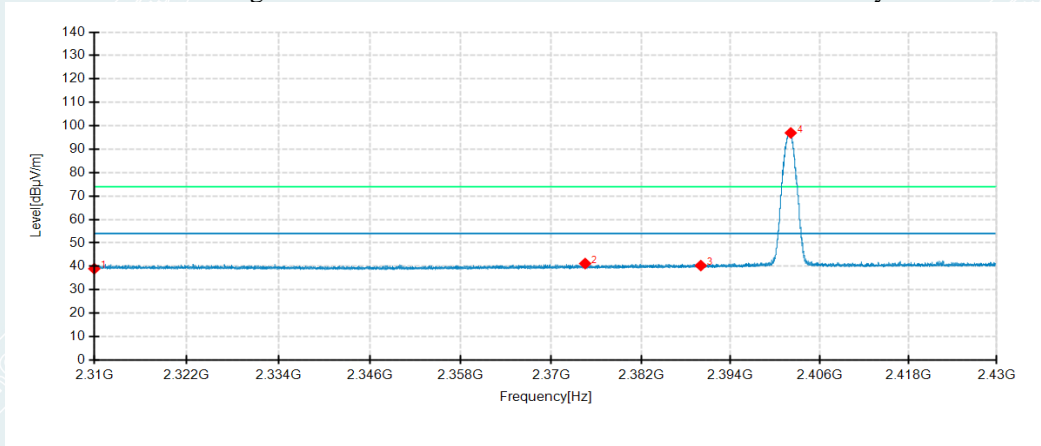

Detector mode: Average

Polarity: Vertical

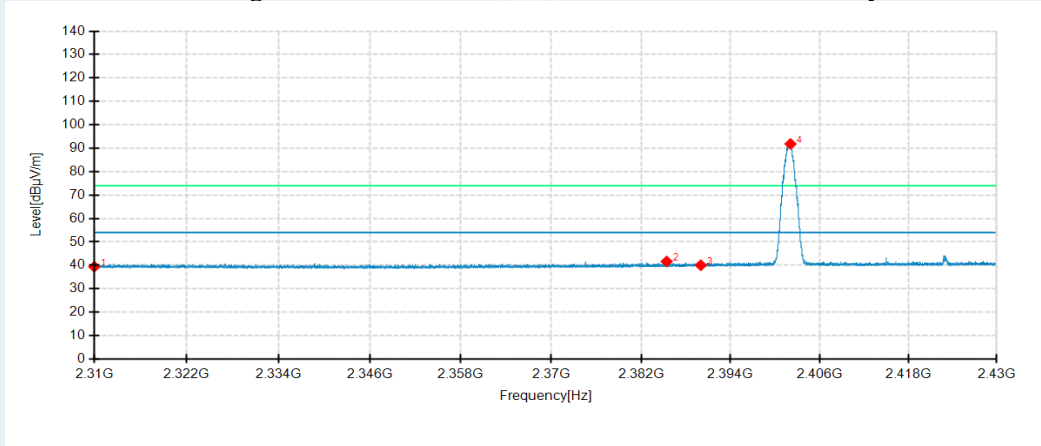

No.	Frequency MHz	Reading dBµV/m	Level dBµV/m	Factor dB	Limit dBµV/m	Margin dB	Height cm	Angle °	Pole	Remark
1	2310.0000	35.50	38.98	3.48	54.00	15.02	100	142	Horizontal	/
2	2374.5360	37.64	41.19	3.55	54.00	12.81	100	244	Horizontal	/
3	2390.0000	36.52	40.33	3.81	54.00	13.67	200	218	Horizontal	/
4	2402.1000	92.98	96.97	3.99	54.00	-42.97	100	300	Horizontal	No limit
1	2310.0000	35.93	39.41	3.48	54.00	14.59	100	191	Vertical	/
2	2385.4200	37.93	41.66	3.73	54.00	12.34	200	313	Vertical	/
3	2390.0000	36.23	40.04	3.81	54.00	13.96	100	218	Vertical	/
4	2402.0640	87.85	91.84	3.99	54.00	-37.84	100	218	Vertical	No limit

**Highest Frequency**  
 Frequency 2480MHz  
 Detector mode: Peak

Polarity: Horizontal

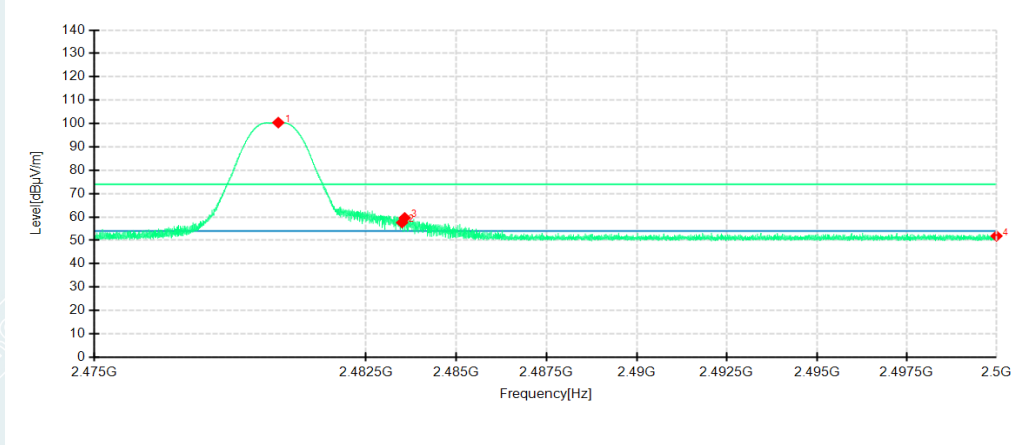

Detector mode: Peak

Polarity: Vertical

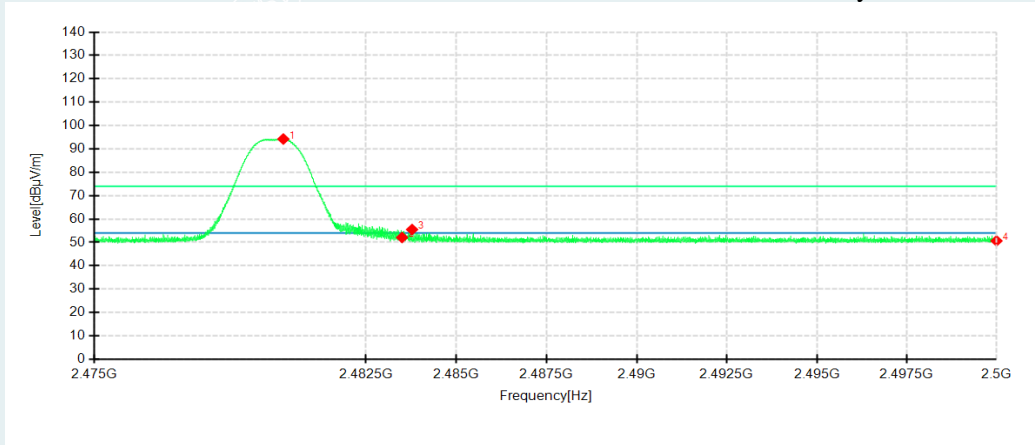

No.	Frequency MHz	Reading dBμV/m	Level dBμV/m	Factor dB	Limit dBuV/m	Margin dB	Height cm	Angle °	Pole	Remark
1	2480.0775	96.07	100.39	4.32	74.00	-26.39	100	142	Horizontal	No limit
2	2483.5000	53.30	57.63	4.33	74.00	16.37	100	294	Horizontal	/
3	2483.5725	55.29	59.62	4.33	74.00	14.38	200	122	Horizontal	/
4	2500.0000	47.49	51.87	4.38	74.00	22.13	100	184	Horizontal	/
1	2480.2175	89.91	94.23	4.32	74.00	-20.23	200	231	Vertical	No limit
2	2483.5000	47.76	52.09	4.33	74.00	21.91	100	218	Vertical	/
3	2483.7775	51.16	55.49	4.33	74.00	18.51	100	218	Vertical	/
4	2500.0000	46.27	50.65	4.38	74.00	23.35	100	33	Vertical	/

**Highest Frequency**

Frequency 2480MHz

Detector mode: Average

Polarity: Horizontal

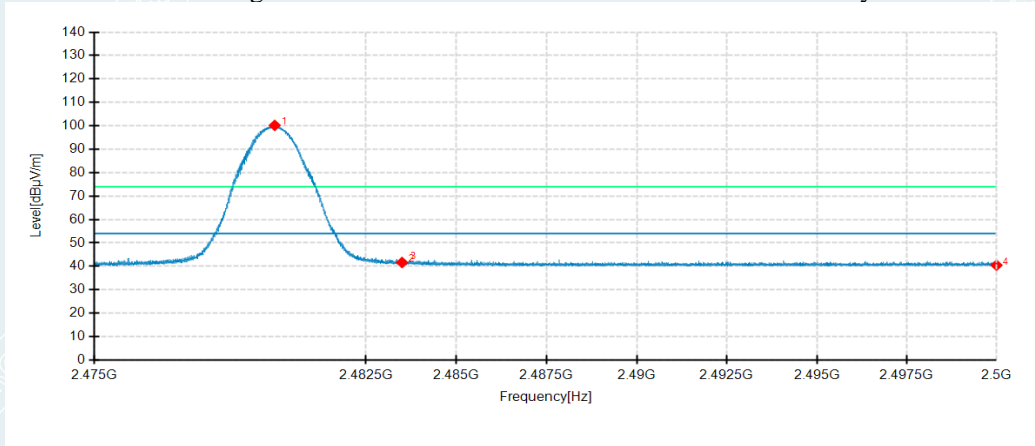

Detector mode: Average

Polarity: Vertical

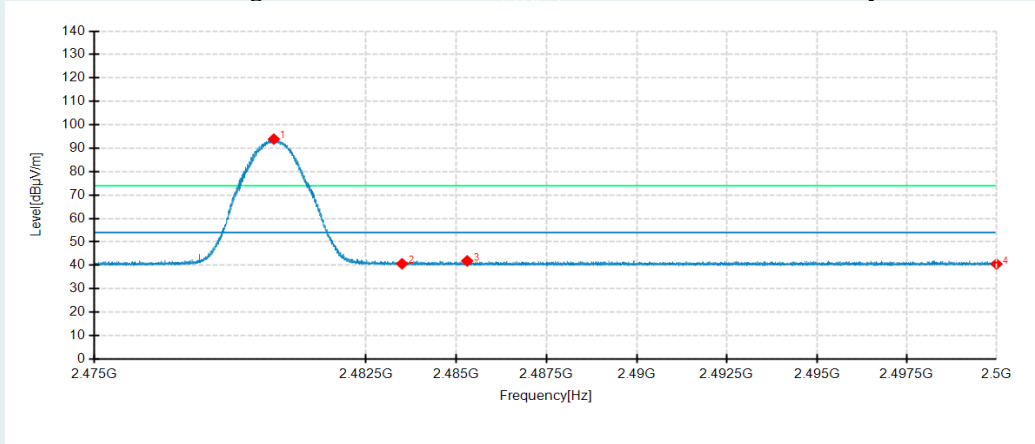

No.	Frequency MHz	Reading dBμV/m	Level dBμV/m	Factor dB	Limit dBuV/m	Margin dB	Height cm	Angle °	Pole	Remark
1	2479.9800	95.86	100.18	4.32	54.00	-46.18	100	142	Horizontal	No limit
2	2483.5000	37.30	41.63	4.33	54.00	12.37	200	121	Horizontal	/
3	2483.5475	38.60	42.93	4.33	54.00	11.07	200	107	Horizontal	/
4	2500.0000	36.10	40.48	4.38	54.00	13.52	200	114	Horizontal	/
1	2479.9550	89.57	93.89	4.32	54.00	-39.89	200	232	Vertical	No limit
2	2483.5000	36.34	40.67	4.33	54.00	13.33	200	314	Vertical	/
3	2485.3025	37.54	41.88	4.34	54.00	12.12	100	136	Vertical	/
4	2500.0000	36.17	40.55	4.38	54.00	13.45	100	211	Vertical	/

Remark: Max field strength in 3m distance. No any other emission which falls in restricted bands can be detected and be reported.

**APPENDIX A. PHOTOGRAPH OF THE TEST CONNECTION DIAGRAM**

Please refer to the attached document E20220126055701-11-Test Photo.

**APPENDIX B. PHOTOGRAPH OF THE EUT**

Please refer to the attached document E20220126055701-9-EUT Photo.

----- End of Report -----

07.10