

FCC RADIO TEST REPORT

For
FCC ID: 2ABYU-E8

Report Reference No..... : 18EFAS11004 11
Date of issue : 2018-10-30
Testing Laboratory : DongGuan ShuoXin Electronic Technology Co., Ltd.
Address : Zone A, 1F, No. 6, XinGang Road YuanGang Street, XinAn
District, ChangAn Town, DongGuan City, GuangDong,
China

Applicant's name..... : Radius Networks, Inc.
Address..... : 3255 Grace Street NW, Washington, Dist of Columbia, United
States

Manufacturer..... : Dongguan Rongmai electronic technology Co., Ltd

Test specification:

Test item description..... : Server
Trade Mark..... : N/A
Model/Type reference..... : E8
Ratings..... : DC 3V

Responsible Engineer :

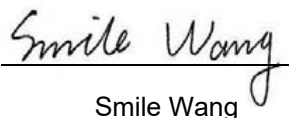
Smile Wang

Authorized Signatory:

King Wang

TABLE OF CONTENTS

| | |
|---|----|
| 1. Summary of test Standards and results | 4 |
| 2.1. Description of EUT | 5 |
| 2.2. Accessories of EUT | 5 |
| 2.3. Assistant equipment used for test..... | 5 |
| 2.4. Block diagram of EUT configuration for test..... | 6 |
| 2.5. Test environment conditions | 6 |
| 2.6. Measurement uncertainty | 7 |
| 3. 6dB Bandwidth and 99% Occupied Bandwidth..... | 8 |
| 3.1. Test equipment | 8 |
| 3.2. Block diagram of test setup..... | 8 |
| 3.3. Limits | 8 |
| 3.4. Test Procedure | 8 |
| 3.. Test Result..... | 9 |
| 3.6. Original test data..... | 10 |
| 4. Maximum Peak Output Power | 12 |
| 4.1. Test equipment | 12 |
| 4.2. Block diagram of test setup..... | 12 |
| 4.3. Limits | 12 |
| 4.4. Test Procedure | 12 |
| 5. Power Spectral Density..... | 14 |
| 5.1. Test equipment | 14 |
| 5.2. Block diagram of test setup..... | 14 |
| 5.3. Limits | 14 |
| 5.5. Test Result..... | 15 |
| 5.6. Original test data..... | 16 |
| 6. Spurious Emissions | 18 |
| 6.1. Test equipment | 18 |
| 6.2. Block diagram of test setup..... | 19 |
| 6.3. Limit | 20 |
| 7. 100 kHz Bandwidth of Frequency Band Edge | 30 |
| 7.1. Test equipment | 30 |
| 7.2. Block diagram of test setup..... | 30 |
| 7.3. Limit | 30 |
| 7.4. Test Procedure | 31 |
| 7.5. Test result | 31 |

| | |
|---|----|
| 8. Conducted Spurious Emissions | 33 |
| 8.1. Test Equipment..... | 33 |
| 8.2. Limit | 33 |
| 8.3. Test Procedure | 33 |
| 8.4. Test result | 34 |
| 9 Power Line Conducted Emission | 37 |
| 9.1 Test equipment | 37 |
| 9.2 Block diagram of test setup..... | 37 |
| 9.3 Power Line Conducted Emission Limits(Class B) | 37 |
| 9.4 Test Procedure | 38 |
| 9.5 Test Result..... | 38 |
| 10. Antenna Requirements | 39 |
| 10.1. Limit | 39 |
| 10.2. Result..... | 39 |

TEST REPORT DECLARE

| | | |
|-----------------------------|---|---|
| Applicant | : | Radius Networks, Inc. |
| Address | : | 3255 Grace Street NW, Washington, Dist of Columbia, United States |
| Equipment under Test | : | Server |
| Model No | : | E8 |
| Trade Mark | : | N/A |
| Manufacturer | : | Dongguan Rongmai electronic technology Co., Ltd |
| Address | : | LingDing No, 10-13. Chukeng Village. DongKeng Town. DongGuan City |

Test Standard Used: FCC Rules and Regulations Part 15 Subpart C (15.247)

Test procedure used: ANSI C63.10:2013, 558074 D01 v05.

We Declare:

The equipment described above is tested by DongGuan ShuoXin Electronic Technology Co., Ltd. and in the configuration tested the equipment complied with the standards specified above. The test results are contained in this test report and DongGuan ShuoXin Electronic Technology Co., Ltd. is assumed of full responsibility for the accuracy and completeness of these tests.

After test and evaluation, our opinion is that the equipment provided for test compliance with the requirement of the above FCC standards.

| | | | |
|----------------------|----------------|------------------------|------------|
| Report No: | 18EFAS11004 11 | | |
| Date of Test: | 2018-10-22 | Date of Report: | 2018-10-29 |

Note: This report applies to above tested sample only. This report shall not be reproduced in parts without written approval of DongGuan ShuoXin Electronic Technology Co., Ltd.

1. Summary of test Standards and results

The EUT have been tested according to the applicable standards as referenced below.

| Description of Test Item | Standard | Results |
|--|---|---------|
| 6dB Bandwidth And 99% Occupied Bandwidth | FCC Part 15.247 (a)(2) | PASS |
| Peak Output Power | FCC Part 15.247(b)(3) | PASS |
| Power Spectral Density | FCC Part 15.247(e) | PASS |
| Spurious Emissions at Antenna Port | FCC Part 15.247(d) | PASS |
| Spurious Emissions | FCC Part 15.205, 15.209, FCC Part 15.247(d) | PASS |
| 100 kHz Bandwidth of Frequency Band Edge | FCC Part 15.247(d) | PASS |
| AC Line Conducted Emissions | FCC Part 15.207 (a) | N/A |
| Antenna requirement | FCC Part 15: 15.203 | PASS |

2. GENERAL TEST INFORMATION

2.1. Description of EUT

| | | |
|--------------------------|---|--|
| EUT* Name | : | Server |
| Model Number | : | E8 |
| Trade Mark | : | N/A |
| EUT function description | : | N/A |
| Power supply | : | DC 3V from battery (1.5V "R20S" battery*8) |
| Adaptor | : | N/A |
| Radio Specification | : | BT 5.0(BLE) |
| Operation frequency | : | 2.402~2.480 GHz |
| Modulation | : | GFSK |
| Antenna Type | : | External Antenna, gain: 3.2dBi |
| FVIN | : | NA |
| Date of Receipt | : | 2018/10/22 |
| Sample Type | : | N/A |

Note: EUT is the ab. of equipment under test.

2.2. Accessories of EUT

| Description of Accessories | Manufacturer | Model number or Type | Other |
|----------------------------|--------------|----------------------|-------|
| / | / | / | / |

2.3. Assistant equipment used for test

| Description of Assistant equipment | Manufacturer | Model number or Type | Other |
|------------------------------------|--------------|----------------------|-------|
| / | / | / | / |

2.4. Block diagram of EUT configuration for test

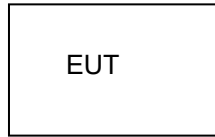

EUT was connected to control to a special test jig provided by manufacturer which has a standard RSS-232 connector to connect to Notebook, and the Notebook will run a special test software “MP_v1.1.1” provided by manufacturer to control EUT work in test mode as blow table.

| Tested mode, channel, and data rate information | | | |
|---|--------------------------------|--------------|--------------------|
| Mode | data rate (Mbps) (see Note) | Channel | Frequency (MHz) |
| BLE | 1 | Low :CH00 | 2402 |
| | 1 | Middle: CH19 | 2440 |
| | 1 | High: CH39 | 2480 |
| Note: According exploratory test, EUT will have maximum output power in those data rate, so those data rate were used for all test. | | | |

2.5. Test environment conditions

During the measurement the environmental conditions were within the listed ranges:

| | |
|--------------------|-----------|
| Temperature range: | 21-25°C |
| Humidity range: | 40-75% |
| Pressure range: | 86-106kPa |

2.6. Measurement uncertainty

| Test Item | Uncertainty |
|---|-----------------------|
| Uncertainty for Conduction emission test (9kHz-150kHz) | 3.7 dB |
| Uncertainty for Conduction emission test (150kHz-30MHz) | 3.3 dB |
| Uncertainty for Radiation Emission test (30MHz-200MHz) | 4.60 dB (Polarize: V) |
| | 4.60 dB (Polarize: H) |
| Uncertainty for Radiation Emission test (200MHz-1GHz) | 6.10 dB (Polarize: V) |
| | 5.08 dB (Polarize: H) |
| Uncertainty for Radiation Emission test (1GHz-6GHz) | 5.01 dB (Polarize: V) |
| | 5.01 dB (Polarize: H) |
| Uncertainty for Radiation Emission test (6GHz-18GHz) | 5.26 dB (Polarize: V) |
| | 5.26 dB (Polarize: H) |
| Uncertainty for Radiation Emission test (18GHz-40GHz) | 5.06 dB (Polarize: V) |
| | 5.06 dB (Polarize: H) |
| Uncertainty for radio frequency | $\pm 0.048\text{kHz}$ |
| Uncertainty for conducted RF Power | $\pm 0.32\text{dB}$ |

Note: This uncertainty represents an expanded uncertainty expressed at approximately the 95% confidence level using a coverage factor of k=2.

3. 6dB Bandwidth and 99% Occupied Bandwidth

3.1. Test equipment

| Item | Equipment | Manufacturer | Model No. | Serial No. | Calibrated until | Calibrated Date |
|------|-------------------|---------------|-------------|------------|------------------|-----------------|
| 1 | Spectrum analyzer | KEYSIGHT | N9010A | MY55150427 | 05/25/2019 | 05/26/2019 |
| 2 | Attenuator | Mini-Circuits | BW-S10W2 | 101109 | 12/17/2018 | 12/18/2017 |
| 3 | RF Cable | Micable | C10-01-01-1 | 100309 | 12/17/2018 | 12/18/2017 |
| 4 | Spectrum analyzer | R&S | FSV40 | 101470 | 06/28/2019 | 06/29/2018 |

3.2. Block diagram of test setup

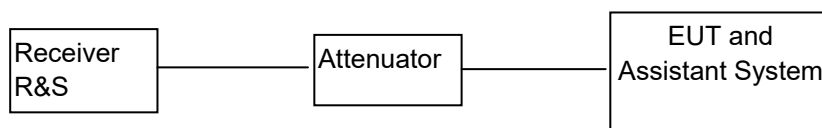

3.3. Limits

For direct sequence systems, the minimum 6dB bandwidth shall be at least 500 KHz

3.4. Test Procedure

- (1) Check the calibration of the measuring instrument using either an internal calibrator or a known signal from an external generator.
- (2) Position the EUT without connection to measurement instrument. Turn on the EUT and connect it to measurement instrument. Then set it to any one convenient frequency within its operating range. Set a reference level on the measuring instrument equal to the highest peak value.
- (3) Measure the frequency difference of two frequencies that were attenuated 6 dB from the reference level. Record the frequency difference as the emission bandwidth.
- (4) Repeat above procedures until all frequencies measured were complete.

3.. Test Result

| EUT Set Mode | CH or Frequency | 6 dB bandwidth | 99% dB bandwidth | Limt | Conclusion |
|--------------|-----------------|----------------|------------------|---------|------------|
| | | Result (MHz) | Result (MHz) | | |
| BLE | CH 00 | 0.637 | / | >500KHz | PASS |
| | CH 19 | 0.641 | / | >500KHz | PASS |
| | CH 39 | 0.654 | / | >500KHz | PASS |

3.6. Original test data

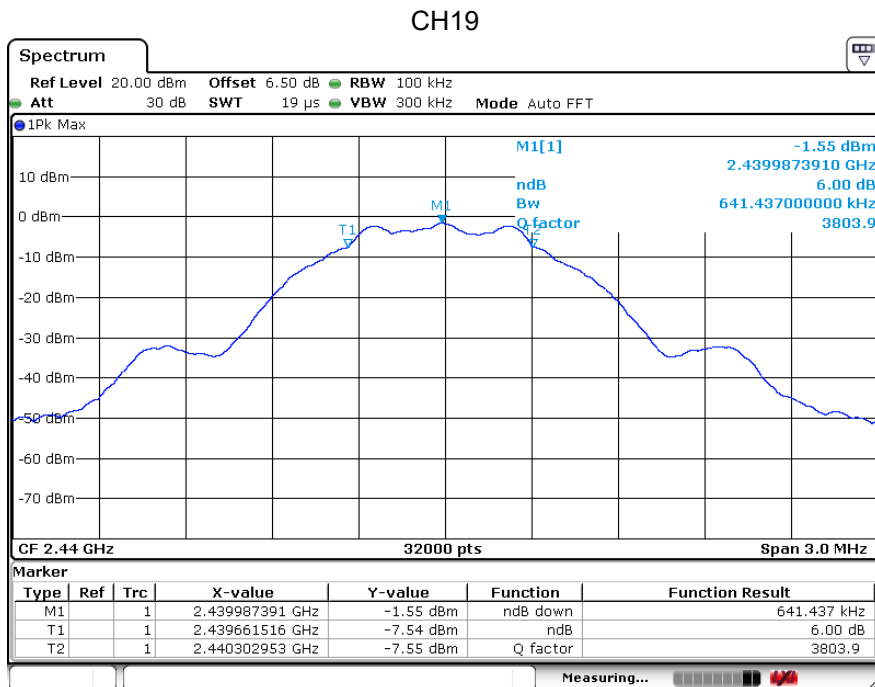
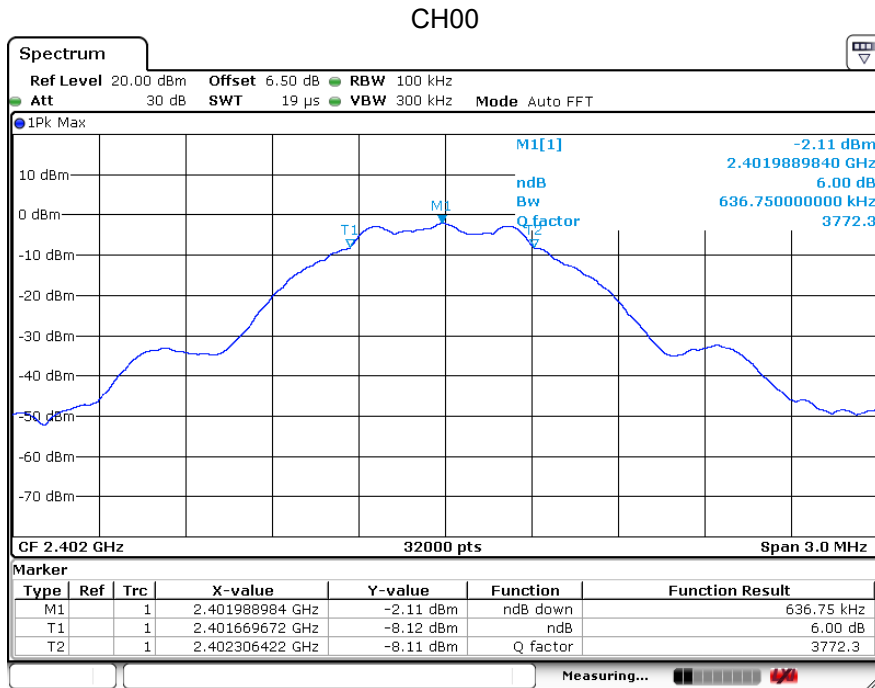

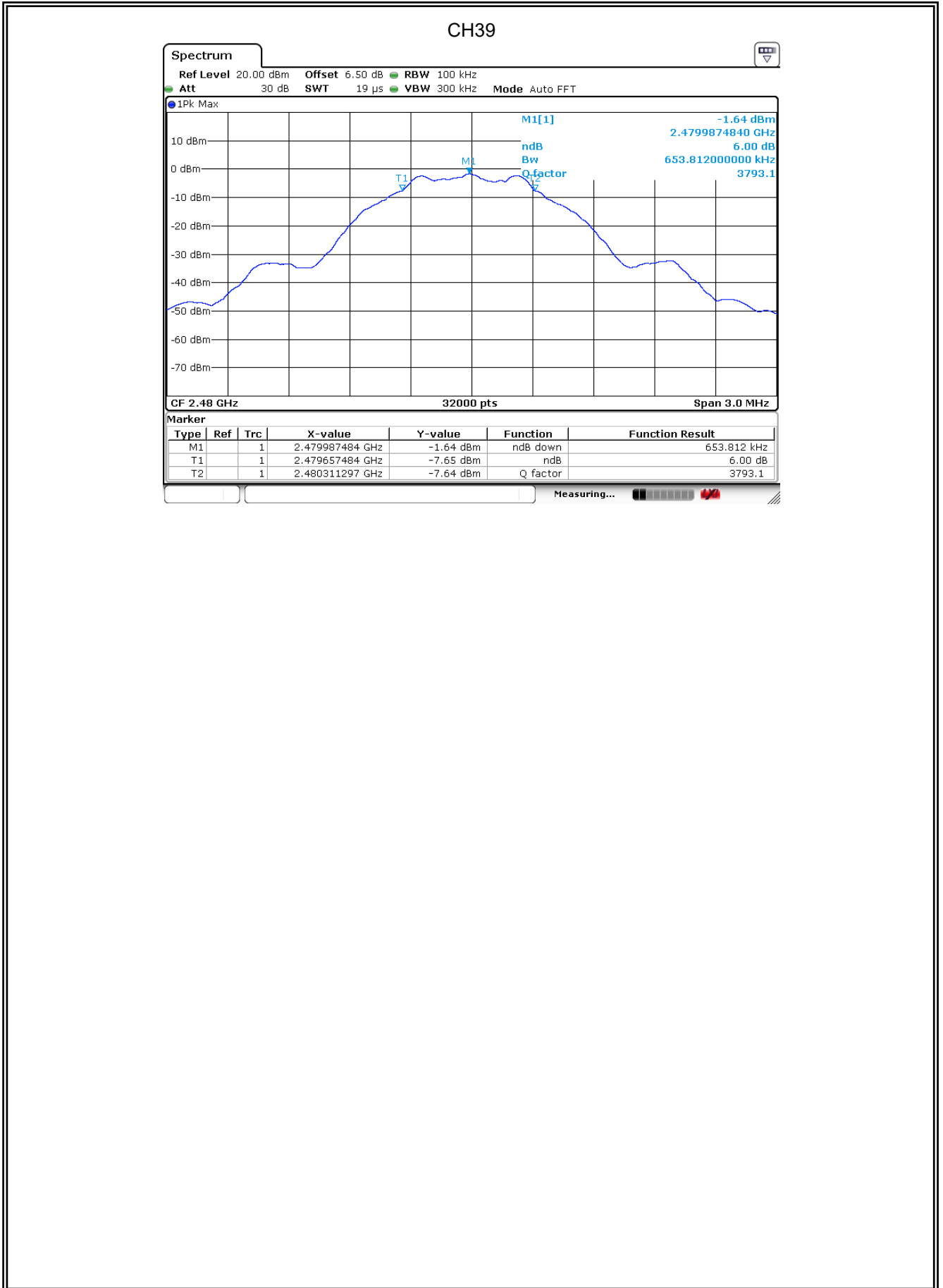

4. Maximum Peak Output Power

4.1. Test equipment

| Item | Equipment | Manufacturer | Model No. | Serial No. | Calibrated until | Calibrated Date |
|------|-----------------------|--------------|-------------|------------|------------------|-----------------|
| 1 | Power meter | Agilent | E4417A | MY45100473 | 05/26/2019 | 05/27/2018 |
| 2 | Wireband Power sensor | Agilent | E4427A | MY5100041 | 12/17/2018 | 12/18/2017 |
| 3 | RF Cable | Micable | C10-01-01-1 | 100309 | 12/17/2018 | 12/18/2017 |
| 4 | Spectrum analyzer | R&S | FSV40 | 101470 | 06/28/2019 | 06/29/2018 |

4.2. Block diagram of test setup

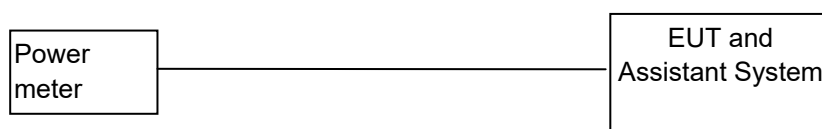

4.3. Limits

For systems using digital modulation in the 902-928 MHz, 2400-2483.5 MHz bands: 1 Watt. If transmitting antennas of directional gain greater than 6 dBi are used, the conducted output power from the intentional radiator shall be reduced below the stated values as appropriate, by the amount in dB that the directional gain of the antenna exceeds 6 dBi.

4.4. Test Procedure

1. Place the EUT on a bench and set it in transmitting mode.
2. A wide band power meter with a matched thermocouple detector was used to directly measure the output power from the RF output port of the EUT in continuously transmitting mode.
3. The measurement shall be repeated at the lowest, the middle, and the highest channel of the stated frequency range.

4.5. TEST RESULT

| EUT Set Mode | CH | Result(dBm) Peak | Total Power (dBm) | Limit | Conclusion |
|--------------|-------|---------------------|----------------------|-------|------------|
| BLE | CH 00 | -1.63 | / | 30dBm | PASS |
| | CH 19 | -0.63 | / | 30dBm | PASS |
| | CH 39 | -0.05 | / | 30dBm | PASS |

5. Power Spectral Density

5.1. Test equipment

| Item | Equipment | Manufacturer | Model No. | Serial No. | Calibrated until | Calibrated Date |
|------|-------------------|---------------|-------------|------------|------------------|-----------------|
| 1 | Spectrum analyzer | KEYSIGHT | N9010A | MY55150427 | 05/26/2019 | 05/27/2018 |
| 2 | Attenuator | Mini-Circuits | BW-S10W2 | 101109 | 12/17/2018 | 12/18/2017 |
| 3 | RF Cable | Micable | C10-01-01-1 | 100309 | 12/17/2018 | 12/18/2017 |
| 4 | Spectrum analyzer | R&S | FSV40 | 101470 | 06/28/2019 | 06/29/2018 |

5.2. Block diagram of test setup

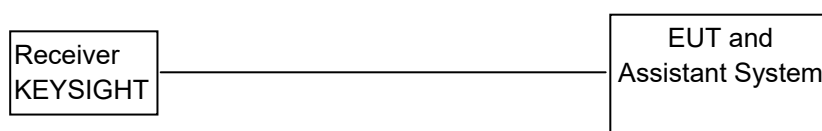

5.3. Limits

For digitally modulated systems, the power spectral density conducted from the intentional radiator to the antenna shall not be greater than 8dBm in any 3 kHz band during any time interval of continuous transmission.

5.4. TEST PROCEDURE

1. Check the calibration of the measuring instrument using either an internal calibrator or a known signal from an external generatorl.
2. Position the EUT was set without connection to measurement instrument. Turn on the EUT and connect its antenna terminal to measurement instrument via a low loss cable. Then set it to any one measured frequency within its operating range, and make sure the instrument is operated in its linear range
3. According to KDB 558074 D01 DTS Meas Guidance v03, set the RBW = 3 kHz, VBW = 30 kHz, Set the span to 1.5 times the DTS channel bandwidth.
4. Use the peak marker function to determine the maximum power level in any 3 kHz band segment within the fundamental EBW

5.5. Test Result

| EUT Set Mode | CH | Result(dBm) | Total (dBm) | Limit (dBm) | Conclusion |
|--------------|-------|-------------|-------------|-------------|------------|
| BLE | CH 00 | -17.01 | / | 8 | PASS |
| | CH 19 | -16.30 | / | 8 | PASS |
| | CH 39 | -16.37 | / | 8 | PASS |

5.6. Original test data

CH00

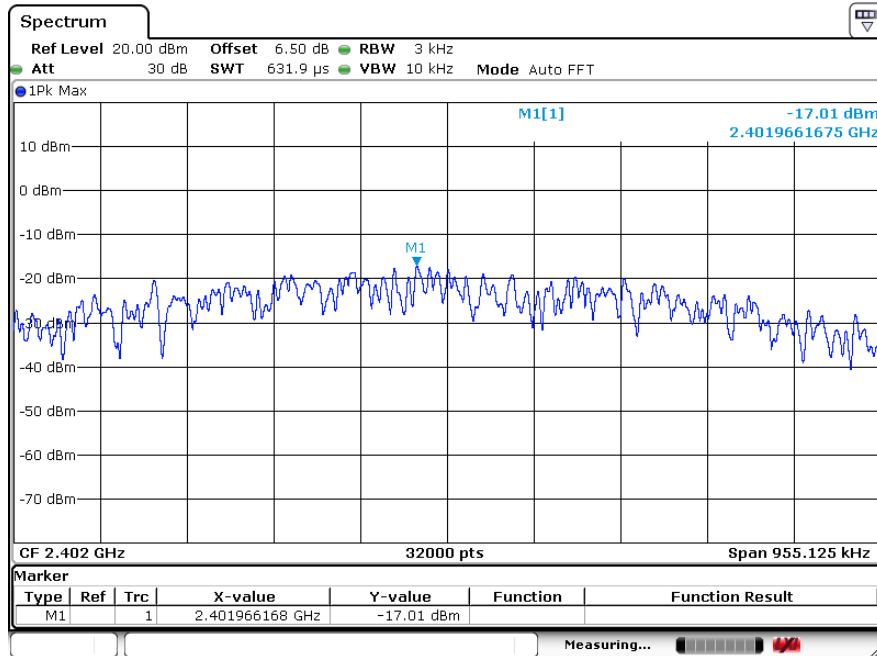

CH19

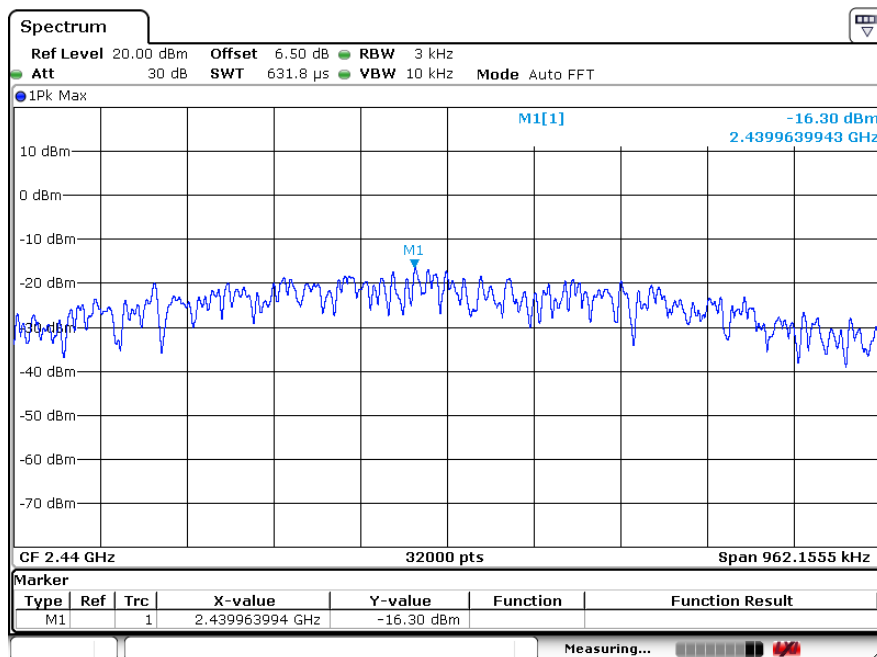

CH39

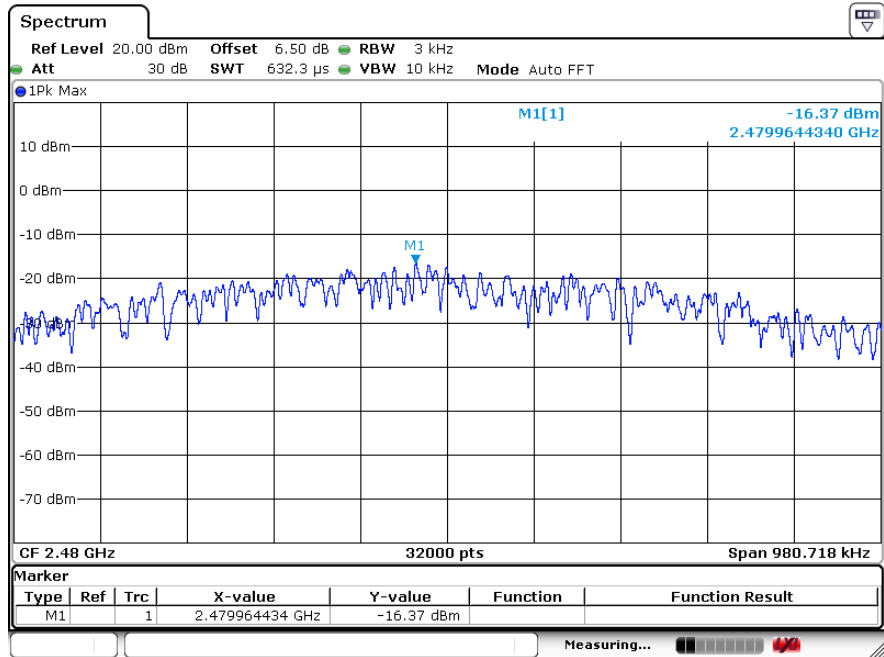

6. Spurious Emissions

6.1. Test equipment

| Item | Equipment | Manufacturer | Model No. | Serial No. | Calibrated until | Calibrated Date |
|------|----------------------------|--------------|-----------------------|--------------|------------------|-----------------|
| 1 | EMI Test Receiver | R&S | ESCI | 101307 | 12/17/2018 | 12/18/2017 |
| 2 | Spectrum analyzer | Agilent | E4407B | US40240708 | 07/04/2019 | 07/05/2018 |
| 3 | Trilog Broadband Antenna | Schwarzbeck | VULB9168 | VULB9168-192 | 03/04/2019 | 03/05/2018 |
| 4 | Double Ridged Horn Antenna | SCHWARZBEC K | BBHA 9120D1065 | 100276 | 12/17/2018 | 12/18/2017 |
| 5 | Double Ridged Horn Antenna | SCHWARZBEC K | BBHA 9120D1065 | 100546 | 12/17/2018 | 12/18/2017 |
| 6 | Dipole antenna | Schwarzbeck | UHAP | 1101 | 12/17/2018 | 12/18/2017 |
| 7 | Dipole antenna | Schwarzbeck | VHAP | 1118 | 12/17/2018 | 12/18/2017 |
| 8 | Pre-Amplifier | CY | EMC011830 | 980136 | 12/17/2018 | 12/18/2017 |
| 9 | Pre-amplifier | HP | 8447F | 3113A05680 | 12/17/2018 | 12/18/2017 |
| 10 | RF Cable | R&S | R01 | 10403 | 12/17/2018 | 12/18/2017 |
| 11 | RF Cable | R&S | R02 | 10512 | 12/17/2018 | 12/18/2017 |
| 12 | RF Cable | R&S | R01 | 10454 | 12/17/2018 | 12/18/2017 |
| 13 | RF Cable | R&S | R02 | 10343 | 12/17/2018 | 12/18/2017 |
| 14 | 6 dB Attenuator | EMEC | ATT6000-6-N N | N/A | 11/21/2018 | 11/22/2017 |
| 15 | Turn Table | UC | UC3000 | N/A | N/A | N/A |
| 16 | Antenna Mast | UC | UC3000 | N/A | N/A | N/A |
| 17 | Measurement Software | Farad | EZ-EMC (Ver.ATT-03 A) | N/A | N/A | N/A |
| 18 | Spectrum analyzer | R&S | FSV40 | 101470 | 06/28/2019 | 06/29/2018 |

6.2. Block diagram of test setup

In 3m Anechoic Chamber Test Setup Diagram for below 1GHz

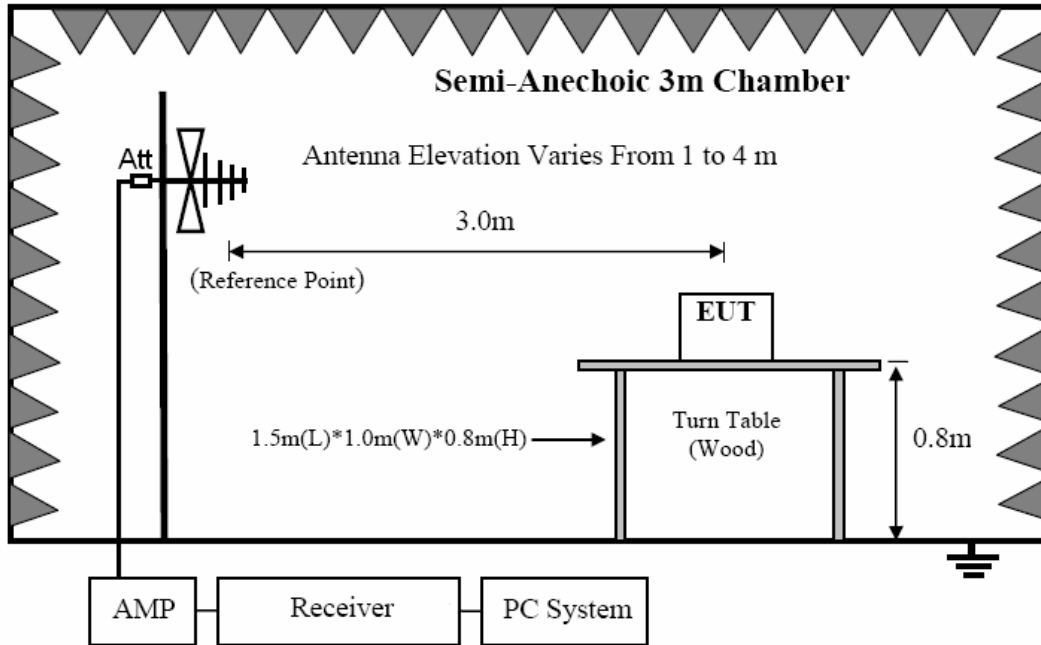

In 3m Anechoic Chamber Test Setup Diagram for frequency above 1GHz

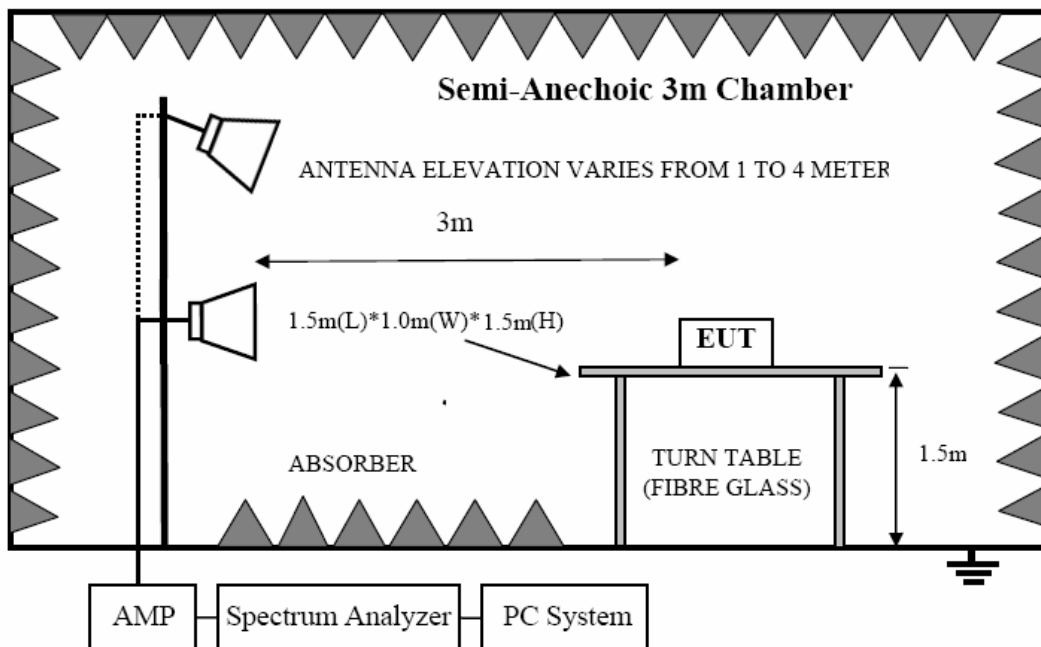

Note: For harmonic emissions test a appropriate high pass filter was inserted in the input port of AMP.

6.3. Limit

6.3.1 FCC 15.205 Restricted frequency band

| MHz | MHz | MHz | GHz |
|----------------------------|-----------------------|-----------------|------------------|
| 0.090 - 0.110 | 16.42 - 16.423 | 399.9 - 410 | 4.5 - 5.15 |
| ¹ 0.495 - 0.505 | 16.69475 - 16.69525 | 608 - 614 | 5.35 - 5.46 |
| 2.1735 - 2.1905 | 16.80425 - 16.80475 | 960 - 1240 | 7.25 - 7.75 |
| 4.125 - 4.128 | 25.5 - 25.67 | 1300 - 1427 | 8.025 - 8.5 |
| 4.17725 - 4.17775 | 37.5 - 38.25 | 1435 - 1626.5 | 9.0 - 9.2 |
| 4.20725 - 4.20775 | 73 - 74.6 | 1645.5 - 1646.5 | 9.3 - 9.5 |
| 6.215 - 6.218 | 74.8 - 75.2 | 1660 - 1710 | 10.6 - 12.7 |
| 6.26775 - 6.26825 | 108 - 121.94 | 1718.8 - 1722.2 | 13.25 - 13.4 |
| 6.31175 - 6.31225 | 123 - 138 | 2200 - 2300 | 14.47 - 14.5 |
| 8.291 - 8.294 | 149.9 - 150.05 | 2310 - 2390 | 15.35 - 16.2 |
| 8.362 - 8.366 | 156.52475 - 156.52525 | 2483.5 - 2500 | 17.7 - 21.4 |
| 8.37625 - 8.38675 | 156.7 - 156.9 | 2690 - 2900 | 22.01 - 23.12 |
| 8.41425 - 8.41475 | 162.0125 - 167.17 | 3260 - 3267 | 23.6 - 24.0 |
| 12.29 - 12.293 | 167.72 - 173.2 | 3332 - 3339 | 31.2 - 31.8 |
| 12.51975 - 12.52025 | 240 - 285 | 3345.8 - 3358 | 36.43 - 36.5 |
| 12.57675 - 12.57725 | 322 - 335.4 | 3600 - 4400 | (²) |

6.3.2 FCC 15.209 Limit

| FREQUENCY MHz | DISTANCE Meters | FIELD STRENGTHS LIMIT | |
|------------------|--------------------|---|-----------------------------------|
| | | $\mu\text{V}/\text{m}$ | $\text{dB}(\mu\text{V})/\text{m}$ |
| 30 ~ 88 | 3 | 100 | 40.0 |
| 88 ~ 216 | 3 | 150 | 43.5 |
| 216 ~ 960 | 3 | 200 | 46.0 |
| 960 ~ 1000 | 3 | 500 | 54.0 |
| Above 1000 | 3 | 74.0 $\text{dB}(\mu\text{V})/\text{m}$ (Peak) 54.0 $\text{dB}(\mu\text{V})/\text{m}$ (Average) | |

6.3.3 Limit for this EUT

The radiated emission tests were performed in the 3 meters test site, using the setup accordance with the ANSI C63.10:2013. The specification used was the FCC 15.209, and FCC 15.247 limits.

6.4. TEST PROCEDURE

- (1) EUT was placed on a non-metallic table, 80 cm above the ground plane inside a semi-anechoic chamber.
- (2) Setup EUT and assistant system according clause 2.4 and 8.2
- (3) Test antenna was located 3m from the EUT on an adjustable mast. Below pre-scan procedure was first performed in order to find prominent radiated emissions.
 - (a) Change work frequency or channel of device if practicable.
 - (b) Change modulation type of device if practicable.
 - (c) Change power supply range from 85% to 115% of the rated supply voltage
 - (d) Rotated EUT though three orthogonal axes to determine the attitude of EUT arrangement produces highest emissions
- (4) Spectrum frequency from 9MHz to 25GHz (tenth harmonic of fundamental frequency) was investigated, and no any obvious emission were detected from 9KHz to 30MHz and 18GHz to 25GHz, so below final test was performed with frequency range from 30MHz to 18GHz.
- (5) For final emissions measurements at each frequency of interest, the EUT were rotated and the antenna height was varied between 1m and 4m in order to maximize the emission. Measurements in both horizontal and vertical polarities were made and the data was recorded. In order to find the maximum emission, the relative positions of equipments and all of the interface cables were changed according to ANSI C63.10 2013 on Radiated Emission test.
- (6) For emissions from 30MHz to 1GHz, Quasi-Peak values were measured with EMI Receiver and the bandwidth of Receiver is 120 KHz.
- (7) For emissions above 1GHz, both Peak and Average level were measured with Spectrum Analyzer, and the RBW is set at 1MHz, VBW is set at 3MHz for Peak measure, Detector is at PK; RBW is set at 1MHz, VBW is set at 3MHz for Average measure, Detector is at RMS..

6.5. TEST RESULT

Below 30M

| | | | |
|----------------------|--------------|---------------------------|--------------------|
| EUT: | Server | Model No.: | E8 |
| Temperature: | 24°C | Relative Humidity: | 55% |
| Distance: | 3m | Test Power: | DC 3V from battery |
| Polarization: | -- | Test Result: | Pass |
| Test Mode: | Keep TX Mode | Test By: | smile |

| Freq. | Reading | Limit | Margin | State |
|-------|----------|----------|--------|-------|
| (MHz) | (dBuV/m) | (dBuV/m) | (dB) | P/F |
| -- | -- | -- | -- | P |
| -- | -- | -- | -- | P |

Note:

The amplitude of spurious emissions which are attenuated by more than 20dB below the permissible value has no need to be reported.

Distance extrapolation factor = $20 \log(\text{specific distance}/\text{test distance})$ (dB);

Limit line = specific limits(dBuv) + distance extrapolation factor

Between 30M – 1000 MHz

| | | | |
|----------------------|----------------------------|---------------------------|--------------------|
| EUT: | Server | Model No.: | E8 |
| Temperature: | 24 | Relative Humidity: | 55% |
| Distance: | 3m | Test Power: | DC 3V from battery |
| Polarization: | Vertical | Test Result: | Pass |
| Standard: | (RE)FCC PART 15 class B 3m | Test By: | smile |
| Test Mode: | Keep TX Mode | | |

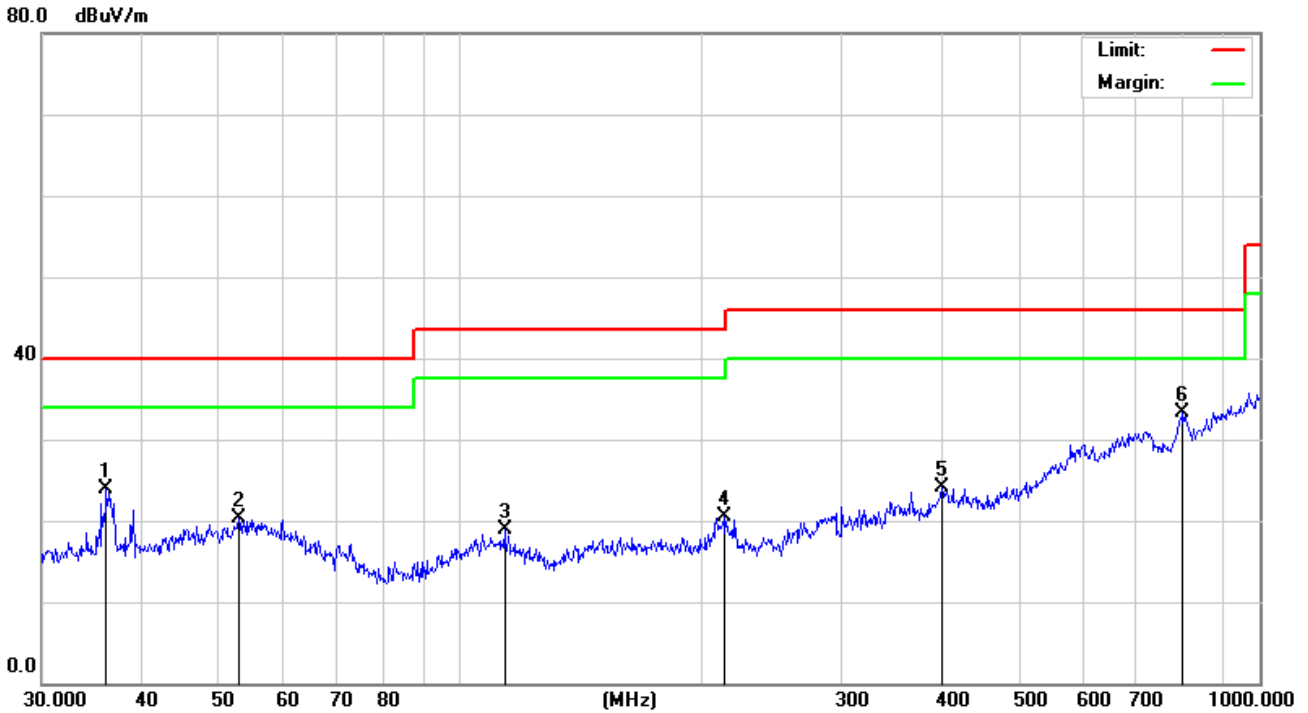

| No. | Mk. | Freq. MHz | Reading Level dBuV | Correct Factor dB | Measurement dBuV/m | Limit dBuV/m | Over dB | Detector |
|-----|-----|--------------|--------------------------|-------------------------|-----------------------|-----------------|------------|----------|
| 1 | | 36.1272 | 36.30 | -12.39 | 23.91 | 40.00 | -16.09 | QP |
| 2 | | 52.9453 | 30.40 | -10.04 | 20.36 | 40.00 | -19.64 | QP |
| 3 | | 113.7142 | 32.46 | -13.47 | 18.99 | 43.50 | -24.51 | QP |
| 4 | | 213.7633 | 33.27 | -12.73 | 20.54 | 43.50 | -22.96 | QP |
| 5 | | 400.4318 | 30.13 | -5.93 | 24.20 | 46.00 | -21.80 | QP |
| 6 | * | 801.7862 | 30.09 | 3.30 | 33.39 | 46.00 | -12.61 | QP |

The test result is calculated as the following:

- (1) Result = Reading + Correct Factor
- (2) Correct Factor = Antenna Factor + Cable Loss – Amplifier Gain + Attenuator
- (3) Margin = Result - Limit

| | | | |
|----------------------|----------------------------|---------------------------|--------------------|
| EUT: | Server | Model No.: | E8 |
| Temperature: | 24 | Relative Humidity: | 55% |
| Distance: | 3m | Test Power: | DC 3V from battery |
| Polarization: | Horizontal | Test Result: | Pass |
| Standard: | (RE)FCC PART 15 class B 3m | Test By: | smile |
| Test Mode: | Keep TX Mode | | |

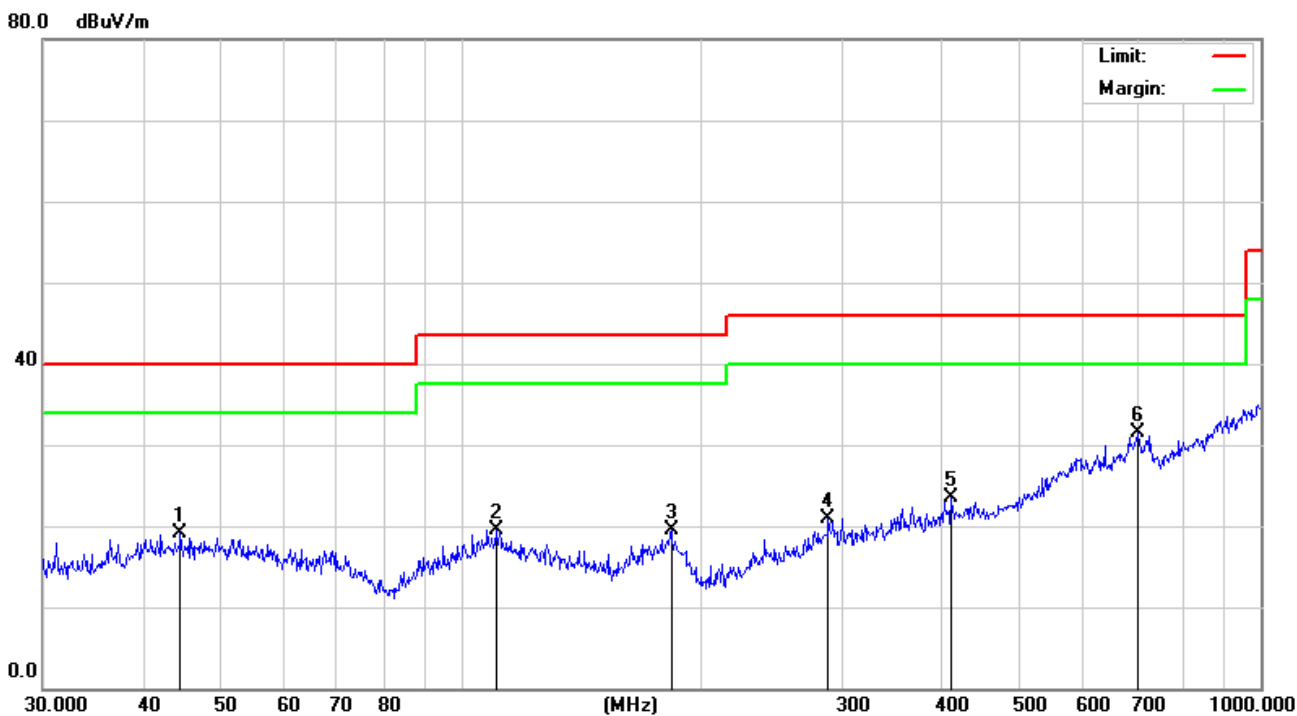

| No. | Mk. | Freq. MHz | Reading Level dBuV | Correct Factor dB | Measure- ment dBuV/m | Limit dBuV/m | Over dB | Detector |
|-----|-----|--------------|--------------------------|-------------------------|----------------------------|-----------------|------------|----------|
| 1 | | 44.5868 | 29.89 | -10.80 | 19.09 | 40.00 | -20.91 | QP |
| 2 | | 110.5687 | 30.96 | -11.48 | 19.48 | 43.50 | -24.02 | QP |
| 3 | | 183.2005 | 30.89 | -11.34 | 19.55 | 43.50 | -23.95 | QP |
| 4 | | 287.9904 | 31.44 | -10.45 | 20.99 | 46.00 | -25.01 | QP |
| 5 | | 410.3825 | 30.15 | -6.62 | 23.53 | 46.00 | -22.47 | QP |
| 6 | * | 701.7610 | 31.12 | 0.32 | 31.44 | 46.00 | -14.56 | QP |

The test result is calculated as the following:

- (1) Result = Reading + Correct Factor
- (2) Correct Factor = Antenna Factor + Cable Loss – Amplifier Gain + Attenuator
- (3) Margin = Result - Limit

Between 1000M – 25000 MHz

| | | | |
|---------------------|---|---------------------|-----------|
| Test Site | : 3m Chamber | | |
| EUT | : Server | Tested By | : Smile |
| Power Supply | : DC 3V from battery | Model Number | : E8 |
| Condition | : Temp:24.5°C,Humi:55%, Press:100.1kPa | Test Mode | : Tx mode |

| Frequency (MHz) | Receiver | | Rx Antenna | | Corrected Amplitude (dB μ V/m) | FCC 15.247 | |
|-----------------------|-------------------------|------------------------|----------------|----------------|--|-------------------------|----------------|
| | Reading (dB μ V) | Detector (PK/QP/AV) | Polar (H/V) | Factor (dB) | | Limit (dB μ V/m) | Margin (dB) |
| Low Channel (2402) | | | | | | | |
| 4804 | 51.40 | PK | H | 5.06 | 56.46 | 74 | -17.54 |
| 4804 | 40.56 | AV | H | 5.06 | 45.62 | 54 | -8.38 |
| 4804 | 51.94 | PK | V | 5.06 | 57.00 | 74 | -17 |
| 4804 | 40.33 | AV | V | 5.06 | 45.39 | 54 | -8.61 |
| 7206 | 42.34 | PK | H | 7.03 | 49.37 | 74 | -24.63 |
| 7206 | 30.22 | AV | H | 7.03 | 37.25 | 54 | -16.75 |
| 7206 | 42.51 | PK | V | 7.03 | 49.54 | 74 | -24.46 |
| 7206 | 30.09 | AV | V | 7.03 | 37.12 | 54 | -16.88 |
| Middle Channel (2440) | | | | | | | |
| 4880 | 52.98 | PK | H | 5.14 | 58.12 | 74 | -15.88 |
| 4880 | 41.13 | AV | H | 5.14 | 46.27 | 54 | -7.73 |
| 4880 | 50.31 | PK | V | 5.14 | 55.45 | 74 | -18.55 |
| 4880 | 38.70 | AV | V | 5.14 | 43.84 | 54 | -10.16 |
| 7320 | 42.92 | PK | H | 7.52 | 50.44 | 74 | -23.56 |
| 7320 | 32.34 | AV | H | 7.52 | 39.86 | 54 | -14.14 |
| 7320 | 41.57 | PK | V | 7.52 | 49.09 | 74 | -24.91 |
| 7320 | 30.57 | AV | V | 7.52 | 38.09 | 54 | -15.91 |
| High Channel (2480) | | | | | | | |
| 4960 | 52.29 | PK | H | 5.22 | 57.51 | 74 | -16.49 |
| 4960 | 40.81 | AV | H | 5.22 | 46.03 | 54 | -7.97 |
| 4960 | 51.62 | PK | V | 5.22 | 56.84 | 74 | -17.16 |
| 4960 | 41.07 | AV | V | 5.22 | 46.29 | 54 | -7.71 |
| 7440 | 42.34 | PK | H | 8.06 | 50.40 | 74 | -23.6 |
| 7440 | 31.17 | AV | H | 8.06 | 39.23 | 54 | -14.77 |
| 7440 | 42.20 | PK | V | 8.06 | 50.26 | 74 | -23.74 |
| 7440 | 30.68 | AV | V | 8.06 | 38.74 | 54 | -15.26 |

The test result is calculated as the following:

- (1) Corrected Amplitude = Read Level + Antenna Factor + Cable loss - Amplifier Gain
- (2) Margin = Corrected Amplitude - Limit

Radiated band edge:

| | | | |
|---------------------|---|---------------------|-----------------------|
| Test Site | : 3m Chamber | Vertical | |
| EUT | : Server | Tested By | : Smile |
| Power Supply | : DC 3V from battery | Model Number | : E8 |
| Condition | : Temp:24.5'C,Humi:55%, Press:100.1kPa | Test Mode | : Tx mode: 1M 2402MHz |

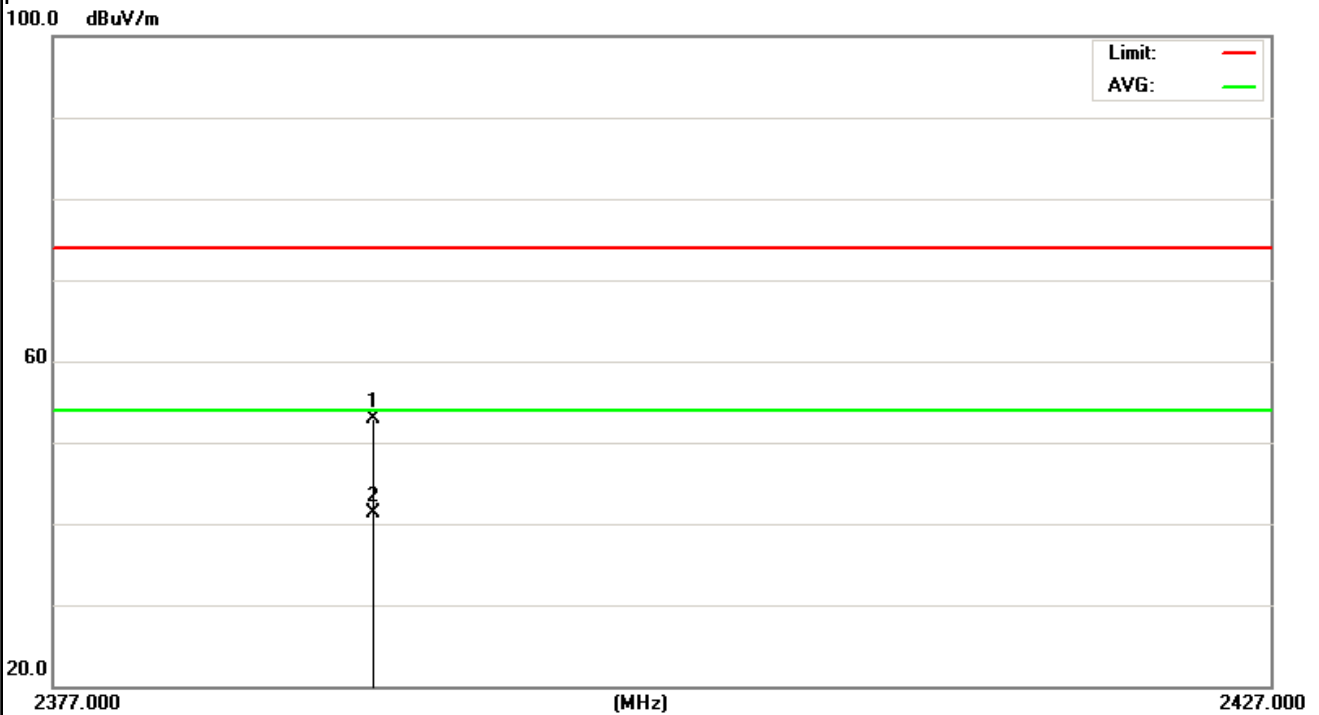

| No. | Frequency (MHz) | Reading (dBuV/m) | Correct Factor(dB/m) | Result (dBuV/m) | Limit (dBuV/m) | Margin (dB) | Remark |
|-----|--------------------|---------------------|-------------------------|--------------------|-------------------|----------------|--------|
| 1 | 2390.000 | 22.04 | 30.85 | 52.89 | 74.00 | -21.11 | peak |
| 2 | 2390.000 | 10.36 | 30.85 | 41.21 | 54.00 | -12.79 | AVG |

The test result is calculated as the following:

- (1) Result = Reading + Correct Factor
- (2) Correct Factor = Antenna Factor + Cable Loss
- (3) Margin = Result - Limit

| | | | |
|---------------------|---|---------------------|-----------------------|
| Test Site | : 3m Chamber | Horizontal | |
| EUT | : Server | Tested By | : Smile |
| Power Supply | : DC 3V from battery | Model Number | : E8 |
| Condition | : Temp:24.5°C,Humi:55%, Press:100.1kPa | Test Mode | : Tx mode: 1M 2402MHz |

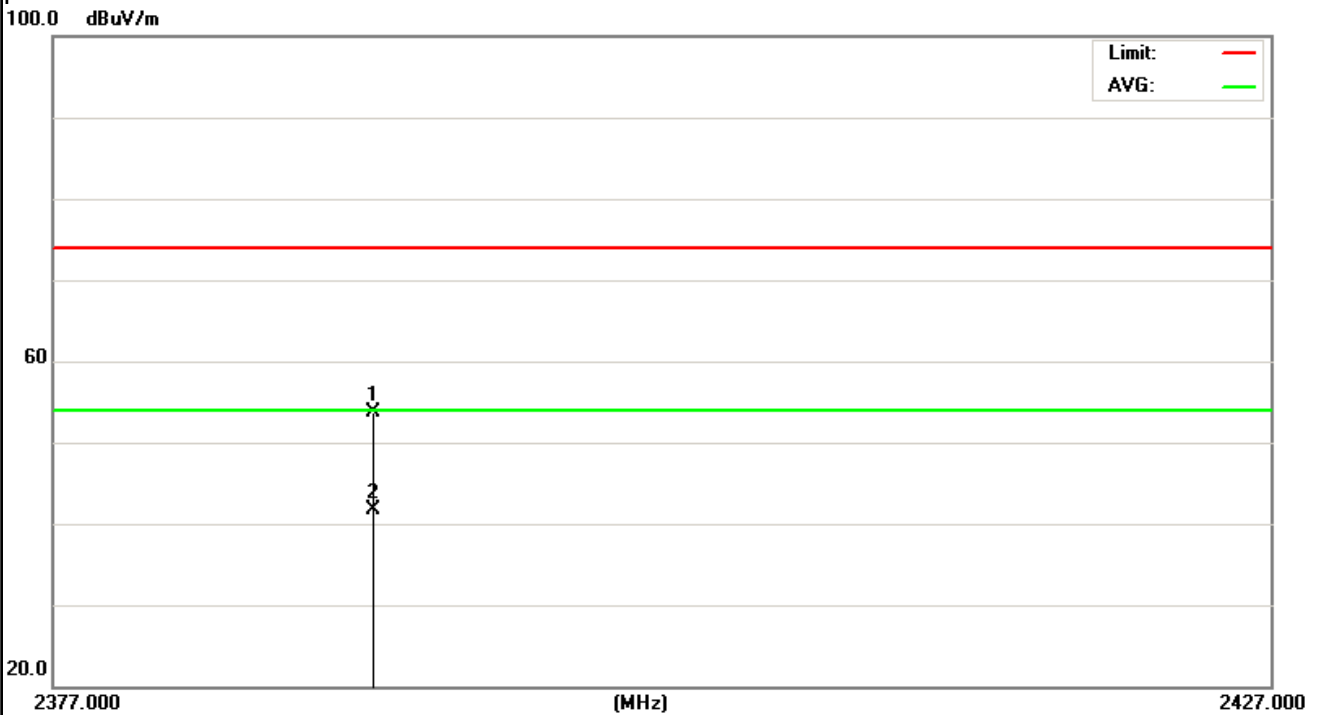

| No. | Frequency (MHz) | Reading (dBuV/m) | Correct Factor(dB/m) | Result (dBuV/m) | Limit (dBuV/m) | Margin (dB) | Remark |
|-----|-----------------|------------------|----------------------|-----------------|----------------|-------------|--------|
| 1 | 2390.000 | 22.92 | 30.85 | 53.77 | 74.00 | -20.23 | peak |
| 2 | 2390.000 | 10.87 | 30.85 | 41.72 | 54.00 | -12.28 | AVG |

The test result is calculated as the following:

- (1) Result = Reading + Correct Factor
- (2) Correct Factor = Antenna Factor + Cable Loss
- (3) Margin = Result - Limit

| | | | |
|---------------------|---|---------------------|-----------------------|
| Test Site | : 3m Chamber | Vertical | |
| EUT | : Server | Tested By | : Smile |
| Power Supply | : DC 3V from battery | Model Number | : E8 |
| Condition | : Temp:24.5°C,Humi:55%, Press:100.1kPa | Test Mode | : Tx mode: 1M 2480MHz |

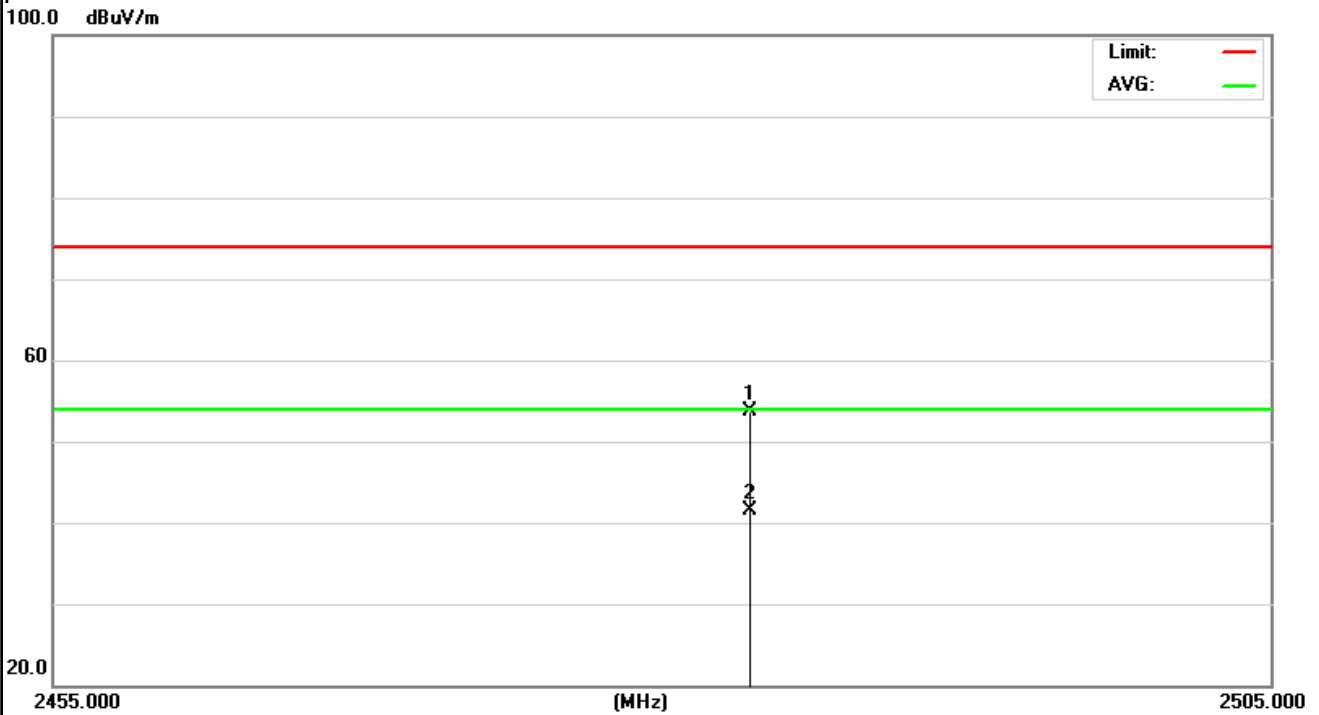

| No. | Frequency (MHz) | Reading (dBuV/m) | Correct Factor(dB/m) | Result (dBuV/m) | Limit (dBuV/m) | Margin (dB) | Remark |
|-----|--------------------|---------------------|-------------------------|--------------------|-------------------|----------------|--------|
| 1 | 2483.500 | 22.68 | 31.07 | 53.75 | 74.00 | -20.25 | peak |
| 2 | 2483.500 | 10.36 | 31.07 | 41.43 | 54.00 | -12.57 | AVG |

The test result is calculated as the following:

- (1) Result = Reading + Correct Factor
- (2) Correct Factor = Antenna Factor + Cable Loss
- (3) Margin = Result - Limit

| | | | |
|---------------------|---|---------------------|-----------------------|
| Test Site | : 3m Chamber | Horizontal | |
| EUT | : Server | Tested By | : Smile |
| Power Supply | : DC 3V from battery | Model Number | : E8 |
| Condition | : Temp:24.5°C,Humi:55%, Press:100.1kPa | Test Mode | : Tx mode: 1M 2480MHz |

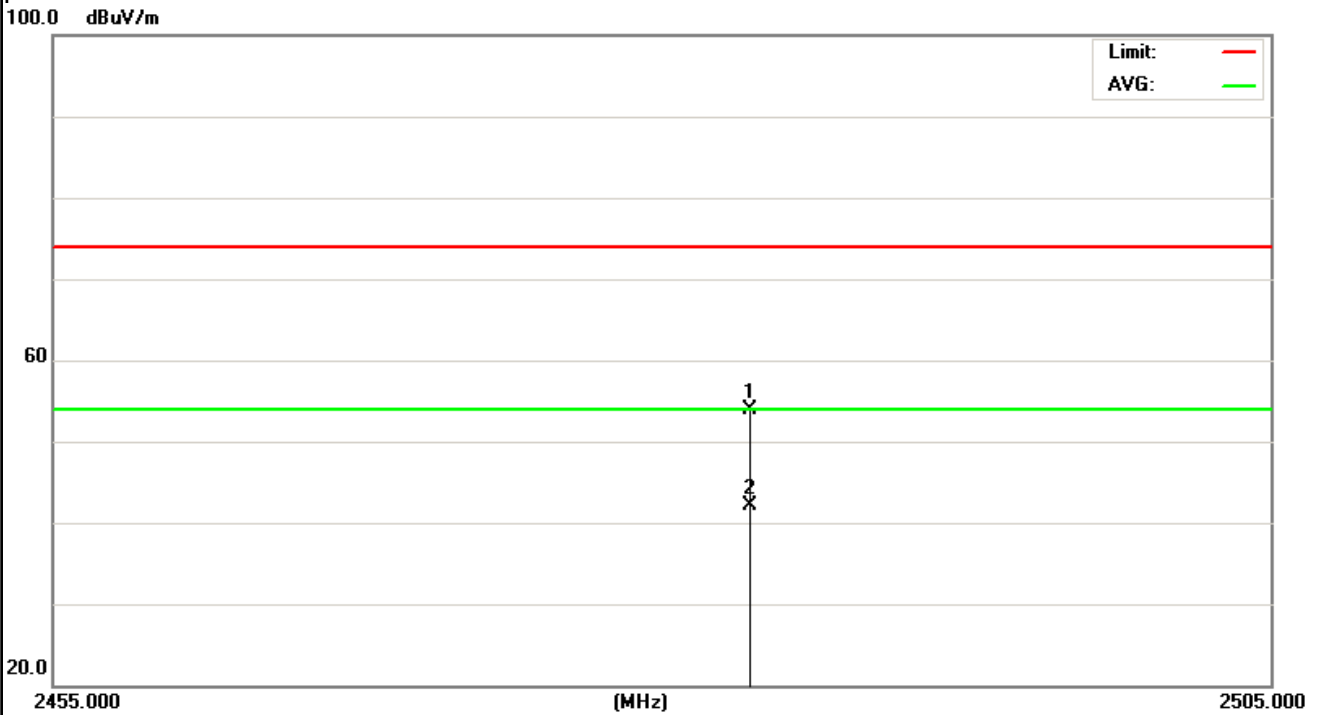

| No. | Frequency (MHz) | Reading (dBuV/m) | Correct Factor(dB/m) | Result (dBuV/m) | Limit (dBuV/m) | Margin (dB) | Remark |
|-----|--------------------|---------------------|-------------------------|--------------------|-------------------|----------------|--------|
| 1 | 2483.500 | 22.89 | 31.07 | 53.96 | 74.00 | -20.04 | peak |
| 2 | 2483.500 | 11.03 | 31.07 | 42.10 | 54.00 | -11.90 | AVG |

The test result is calculated as the following:

- (1) Result = Reading + Correct Factor
- (2) Correct Factor = Antenna Factor + Cable Loss
- (3) Margin = Result - Limit

7. 100 kHz Bandwidth of Frequency Band Edge

7.1. Test equipment

| Item | Equipment | Manufacturer | Model No. | Serial No. | Calibrated until | Calibrated Date |
|------|-------------------|---------------|-------------|------------|------------------|-----------------|
| 1 | Spectrum analyzer | KEYSIGHT | N9010A | MY55150427 | 05/25/2019 | 05/26/2018 |
| 2 | Attenuator | Mini-Circuits | BW-S10W2 | 101109 | 12/17/2018 | 12/18/2017 |
| 3 | RF Cable | Micable | C10-01-01-1 | 100309 | 12/17/2018 | 12/18/2017 |
| 4 | Spectrum analyzer | R&S | FSV40 | 101470 | 06/28/2019 | 06/29/2018 |

7.2. Block diagram of test setup

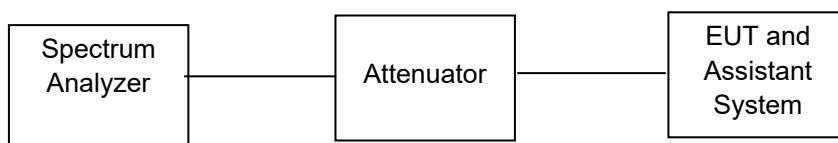

7.3. Limit

In any 100 kHz bandwidth outside the frequency band in which the spread spectrum or digitally modulated intentional radiator is operating, the radio frequency power that is produced by the intentional radiator shall be at least 20 dB below that in the 100 kHz bandwidth within the band that contains the highest level of the desired power, based on either an RF conducted or a radiated measurement, provided the transmitter demonstrates compliance with the peak conducted power limits. If the transmitter complies with the conducted power limits based on the use of RMS averaging over a time interval, as permitted under paragraph (b)(3) of this section, the attenuation required under this paragraph shall be 30 dB instead of 20 dB. Attenuation below the general limits specified in §15.209(a) is not required. In addition, radiated emissions which fall in the restricted bands, as defined in §15.205(a), must also comply with the radiated emission limits specified in §15.209(a) (see §15.205(c)).

7.4. Test Procedure

1. Check the calibration of the measuring instrument using either an internal calibrator or a known signal from an external generator.
2. Remove the antenna from the EUT and then connect to a low loss RF cable from the antenna port to a EMI test receiver, then turn on the EUT and make it operate in transmitting mode. Then set it to Low Channel and High Channel within its operating range, and make sure the instrument is operated in its linear range.
3. Set both RBW and VBW of spectrum analyzer to 100 kHz with a convenient frequency span including 100 kHz bandwidth from band edge.
4. Measure the highest amplitude appearing on spectral display and set it as a reference level. Plot the graph with marking the highest point and edge frequency.
5. Repeat above procedures until all measured frequencies were complete.

7.5. Test result

Pass

BLE Mode

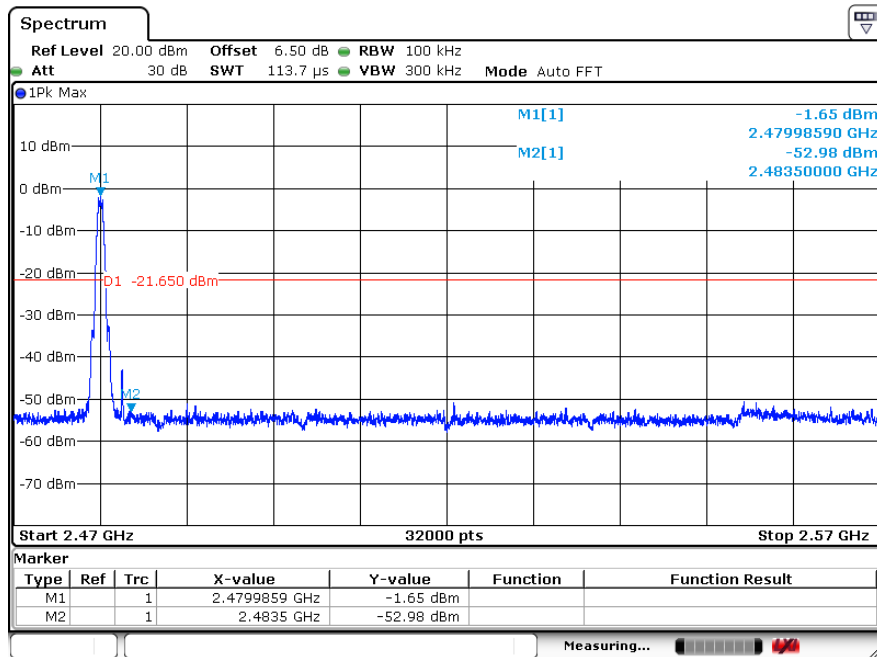
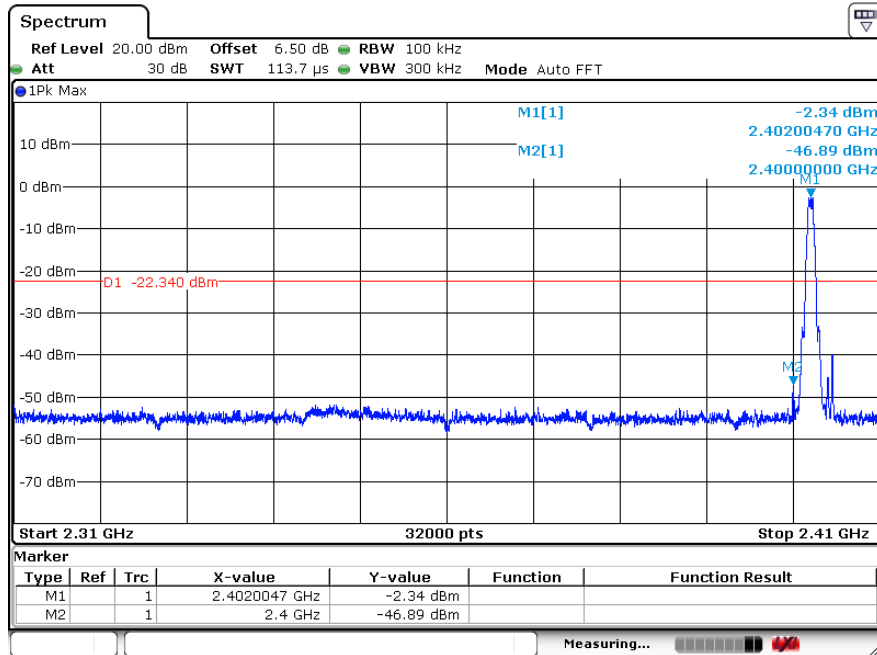

8. Conducted Spurious Emissions

8.1. Test Equipment

| Item | Equipment | Manufacturer | Model No. | Serial No. | Calibrated until | Calibrated Date |
|------|-------------------|---------------|-------------|------------|------------------|-----------------|
| 1 | Spectrum analyzer | KEYSIGHT | N9010A | MY55150427 | 05/26/2019 | 05/27/2018 |
| 2 | Attenuator | Mini-Circuits | BW-S10W2 | 101109 | 12/17/2018 | 12/18/2017 |
| 3 | RF Cable | Micable | C10-01-01-1 | 100309 | 12/17/2018 | 12/18/2017 |
| 4 | Spectrum analyzer | R&S | FSV40 | 101470 | 06/28/2019 | 06/29/2018 |

8.2. Limit

In any 100kHz bandwidth outside the frequency bands in which the spread spectrum intentional radiator is operating, the radio frequency power that is produced by the intentional radiator shall be at least 20dB below that in the 100kHz bandwidth within the band that contains the highest level of the desired power.

8.3. Test Procedure

The transmitter output was connected to a spectrum analyzer, The resolution bandwidth is set to 100 kHz, The video bandwidth is set to 300 kHz and measure all the emissions detected.

8.4. Test result

PASS (See below detailed test result.)

CH00

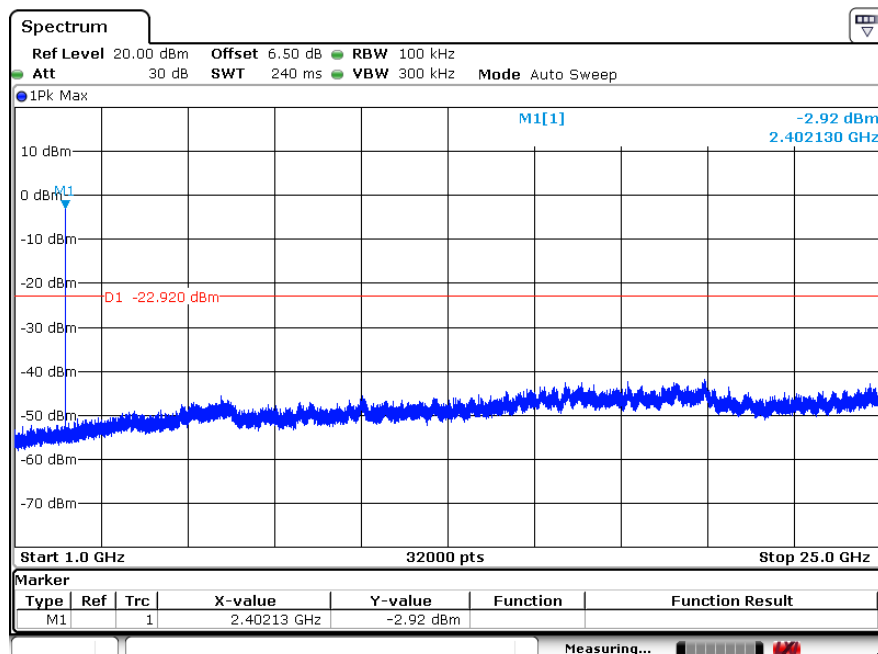
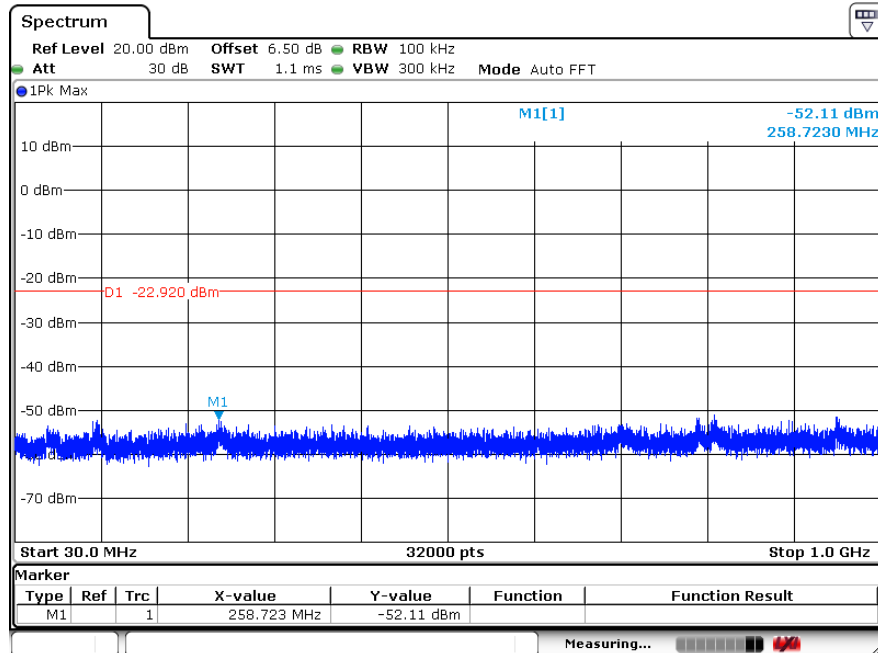

CH19

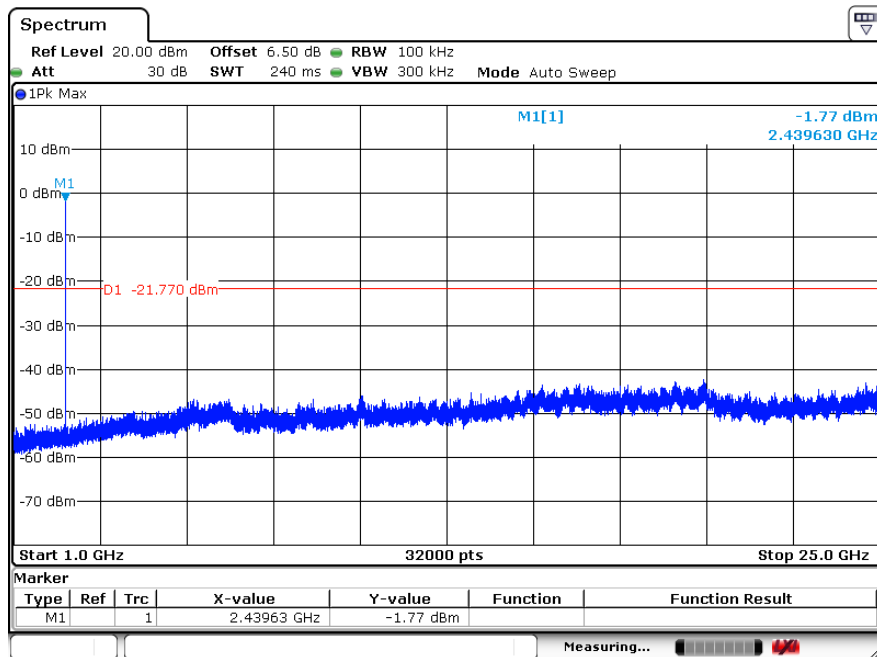
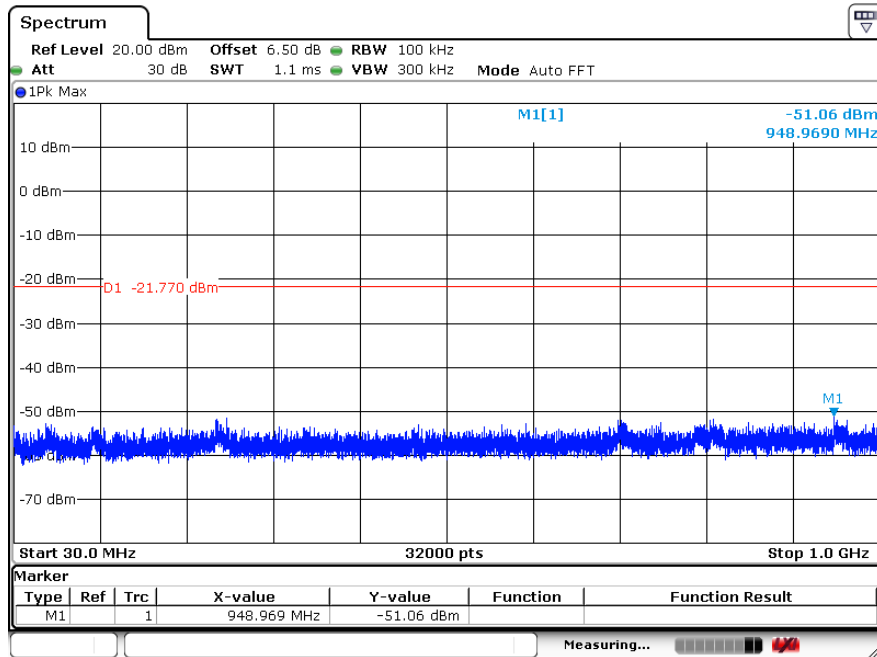

CH39

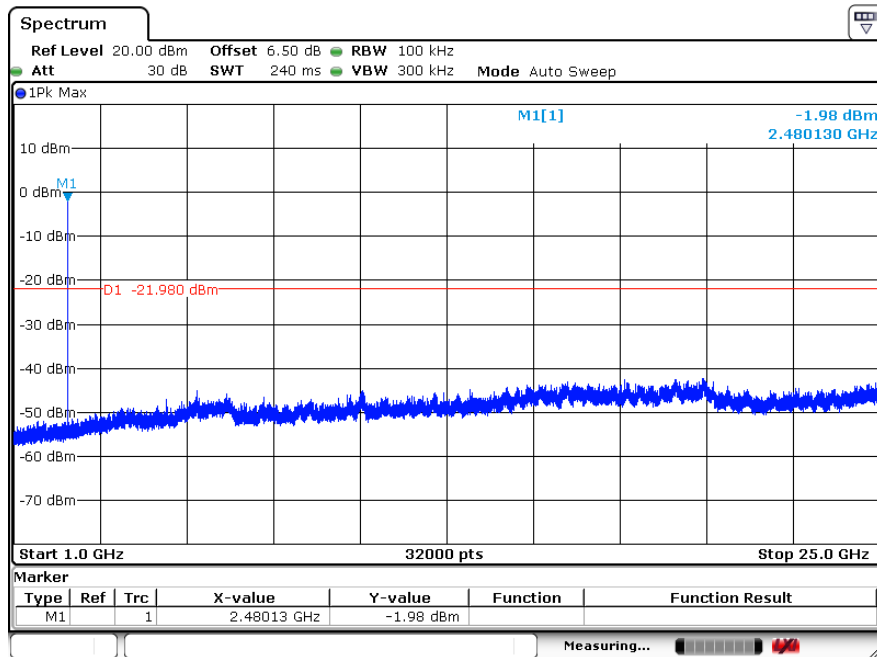
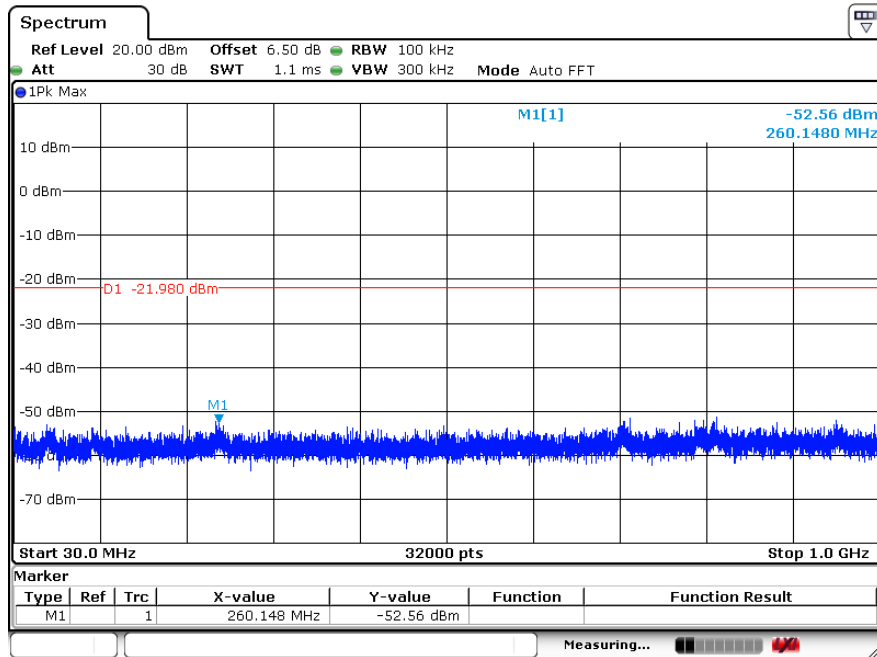

9 Power Line Conducted Emission

9.1 Test equipment

| Item | Kind of Equipment | Manufacturer | Type No. | Serial No. | Calibrated until |
|------|----------------------|-------------------|----------------------|-----------------|------------------|
| 1 | Pulse Limiter | MTS-systemtechnik | MTS-IMP-136 | 261115-010-0024 | 12/17/2018 |
| 2 | EMI Test Receiver | R&S | ESCI | 101308 | 12/17/2018 |
| 3 | LISN | AFJ | LS16 | 16011103219 | 12/17/2018 |
| 4 | LISN | Schwarzbeck | NSLK 8127 | 8127-432 | 12/17/2018 |
| 5 | Measurement Software | Farad | EZ-EMC (Ver.ATT-03A) | N/A | N/A |
| 6 | MeasurementSoftware | Farad | EZ-EMC (Ver.ATT-03A) | N/A | N/A |

9.2 Block diagram of test setup

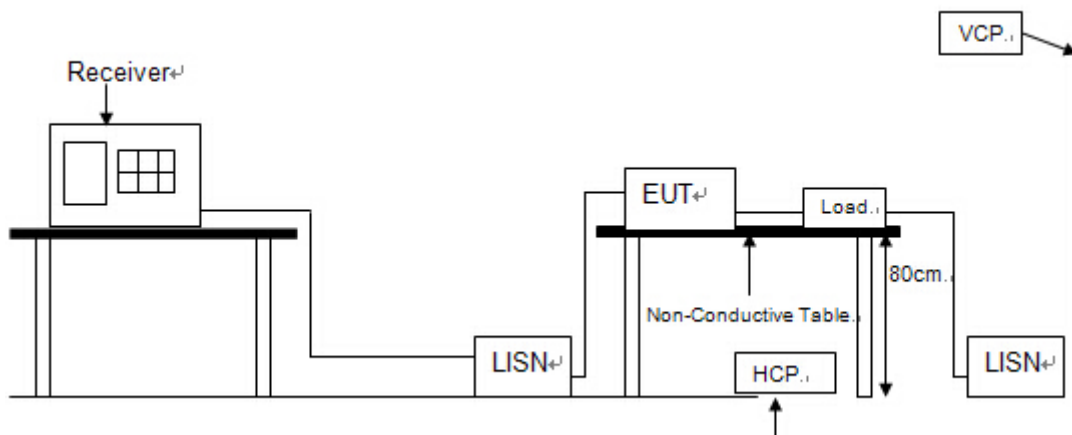

9.3 Power Line Conducted Emission Limits(Class B)

| Frequency | Quasi-Peak Level dB(μ V) | Average Level dB(μ V) |
|-----------------|----------------------------------|-------------------------------|
| 150kHz ~ 500kHz | 66 ~ 56* | 56 ~ 46* |
| 500kHz ~ 5MHz | 56 | 46 |
| 5MHz ~ 30MHz | 60 | 50 |

Note 1: * Decreasing linearly with logarithm of frequency.

Note 2: The lower limit shall apply at the transition frequencies.

9.4 Test Procedure

The EUT and Support equipment, if needed, were put placed on a non-metallic table, 80cm above the ground plane.

Configuration EUT to simulate typical usage as described in clause 2.4 and test equipment as described in clause 10.2 of this report.

All I/O cables were positioned to simulate typical actual usage as per ANSI C63.4.

All support equipment power received from a second LISN.

Emissions were measured on each current carrying line of the EUT using an EMI Test Receiver connected to the LISN powering the EUT.

The Receiver scanned from 150 kHz to 30MHz for emissions in each of the test modes.

During the above scans, the emissions were maximized by cable manipulation.

The test mode(s) described in clause 2.4 were scanned during the preliminary test.

After the preliminary scan, we found the test mode producing the highest emission level.

The EUT configuration and worse cable configuration of the above highest emission levels were recorded for reference of the final test.

EUT and support equipment were set up on the test bench as per the configuration with highest emission level in the preliminary test.

A scan was taken on both power lines, Neutral and Line, recording at least the six highest emissions.

Emission frequency and amplitude were recorded into a computer in which correction factors were used to calculate the emission level and compare reading to the applicable limit.

The test data of the worst-case condition(s) was recorded.

The bandwidth of test receiver is set at 9 KHz.

9.5 Test Result

N/A

10. Antenna Requirements

10.1. Limit

For intentional device, according to FCC 47 CFR Section 15.203, an intentional radiator shall be designed to ensure that no antenna other than that furnished by the responsible party shall be used with the device. And according to FCC 47 CFR Section 15.247 (b), if transmitting antennas of directional gain greater than 6dBi are used, the power shall be reduced by the amount in dB that the directional gain of the antenna exceeds 6dBi.

10.2. Result

See 2.1