

Shenzhen Soruida Electronics Co., LTD	File number	SRD-WI-18465	Issue date	2023-08-17
	edition	A1	Effective date	2023-08-17
STX.505310.10T02 Sample acknowledgement	Number of revisions	1	Page code	1 / 3

editi on	Change the calendar ...		Alteration party	Change time
A	New issue: February 18, 2023		Tang Yangying	2023-02-18
A1	Before change	After the change	Mo Chenghui	2023-08-17
	1. Line length H size: 15.0±2.0 2. High-temperature tape: 6MM 3. Double-sided tape should be attached to the magnetic disc	1. Line length H size: 10.0±2.0 2. High-temperature tape: 3MM 3. Cancel the adhesive backing on the coil surface of the magnetic disc		

Shenzhen Soruida Electronics Co., LTD	File number	SRD-WI-18465	Issue date	2023-08-17
	edition	A1	Effective date	2023-08-17
STX.505310.10T02 Sample acknowledgement	Number of revisions	1	Page code	2 / 3

1. Dimensions: (Unit: mm)

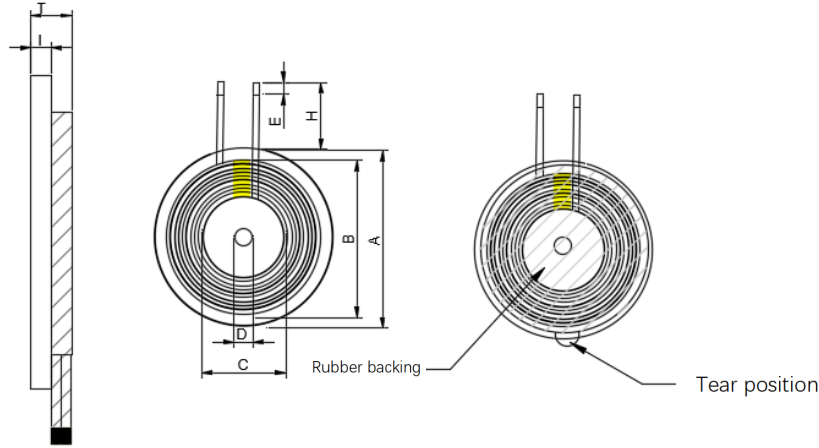

Note: Wrap 3MM (ref) high temperature adhesive paper around coil outlet position

A	B	C	D	E	H	I	T
50.0±1.0	42.5±1.5	20.5±0.5	5.3±0.5	2-5	10.0±2.0	1.0±0.2	3.8Max

2. Electrical characteristic:

Inductance L0	6.5uH±10%	Test condition	10KHz/1V	Testing instrument: ■ HP4287A ■ TH2817C ■ TH2817B/1773 ■ HK502BC ■ CH1062
Direct current resistance (DCR)	45mΩ MAX	Test condition		
Q	70 Min	Test condition	10KHz/1V	
Copper wire diameter	Φ0.08mm*105P			
Number of coils wound	10TS REF	Test condition		

3. Materials:

- (1) Magnetic disc: Φ50*5.3*1.0 ferrite hard magnetic
- (2) Copper wire: 2UEW/F
- (3) High-temperature tape: 3MM

4. electrogram:

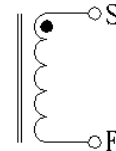

Note:	Modification record:
1: Wrap 3MM (ref) high-temperature adhesive paper around the coil outlet position	1.
2: The back of the magnetic disc should be glued, with hand tear	2:

Shenzhen Soruida Electronics Co., LTD	File number	SRD-WI-18465	Issue date	2023-08-17
	edition	A1	Effective date	2023-08-17
STX.505310.10T02 Sample acknowledgement	Number of revisions	1	Page code	3 / 3

物料清单

Serial number	Material name	supplier	Material specification	DOSAGE		Attrition rate	remark
1	Magnetic sheet	HG	Φ50*5.3*1.0mm	1	PCS	Ferrite hard magnetic	铁氧体硬磁
2	Copper wire	YLSL	G1 P155	/	/	0.02%	
		TPY	2UEW P155	/	/	0.02%	
3	tin	QD	99.7Sn 0.3Cu	0.008	g	0.001%	
4	High-temp erature tape	FW	3.0mm		/	There is no	
5	Rubber backing	XH	White adhesive	1	PCS	There is no	
6							
7							
8							
9							
10							
11							
12							
13							
14							
15							
16							
17							
To prepare note							

Shenzhen Soruida Electronics Co., LTD	File number	SRD-WI-18465	Issue date	2023-08-17
	edition	A1	Effective date	2023-08-17
STX.505310.10T02 Sample acknowledgement	Number of revisions	1	Page code	4 / 3