



# RADIO TEST REPORT

Report No.: STS2210073W01

Issued for

GODOX PHOTO EQUIPMENT CO.,LTD

1st to 4th Floor, Building 2/1st to 4th Floor, Building 4,  
Yaochuan Industrial Zone, Tangwei Community, Fuhai Street,  
Baoan District, Shenzhen 518103, China

<b>Product Name:</b>	MoveLink Mini 2.4GHz Wireless Microphone System (Transmitter)
<b>Brand:</b>	Godox
<b>Model Number:</b>	MoveLink Mini TX
<b>Series Model(s):</b>	N/A
<b>FCC ID:</b>	2ABYN072
<b>Test Standard:</b>	FCC Part 15.249

Any reproduction of this document must be done in full. No single part of this document may be reproduced without permission from STS, All Test Data Presented in this report is only applicable to presented Test sample.





TEST RESULT CERTIFICATION

Applicant's Name .....: GODOX PHOTO EQUIPMENT CO.,LTD
Address .....: 1st to 4th Floor, Building 2/1st to 4th Floor, Building 4, Yaochuan Industrial Zone, Tangwei Community, Fuhai Street, Baoan District, Shenzhen 518103, China
Manufacture's Name .....: GODOX Photo Equipment Co.,Ltd.
Address .....: 4th Floor of Building 1, 1st to 4th Floor of Building 2, 4th Floor of Building 3, 1st to 4th Floor of Building 4, Yaochuan Industrial Zone, Tangwei Community, Fuhai Street, Bao'an District, Shenzhen 518103, China

Product Description

Product Name .....: MoveLink Mini 2.4GHz Wireless Microphone System (Transmitter)
Brand.....: Godox
Model Number.....: MoveLink Mini TX
Series Model(s) .....: N/A
Test Standards.....: FCC Part15.249
Test Procedure .....: ANSI C63.10-2013

This device described above has been tested by STS, the test results show that the equipment under test (EUT) is in compliance with the FCC requirements. And it is applicable only to the tested sample identified in the report.

This report shall not be reproduced except in full, without the written approval of STS, this document only be altered or revised by STS, personal only, and shall be noted in the revision of the document.

Date of Test .....:
Date of receipt of test item .....: 28 Oct. 2022
Date of performance of tests ...: 28 Oct. 2022 ~ 08 Nov. 2022
Date of Issue .....: 08 Nov. 2022
Test Result.....: Pass

Testing Engineer : Chris Chen

(Chris Chen)

Technical Manager : Sean She

(Sean she)

Authorized Signatory : Bovey Yang

(Bovey Yang)





<b>Table of Contents</b>	<b>Page</b>
<b>1. SUMMARY OF TEST RESULTS</b>	<b>5</b>
1.1 TEST FACTORY	6
1.2 MEASUREMENT UNCERTAINTY	6
<b>2. GENERAL INFORMATION</b>	<b>7</b>
2.1 GENERAL DESCRIPTION OF THE EUT	7
2.2 DESCRIPTION OF THE TEST MODES	9
2.3 TEST SOFTWARE AND POWER LEVEL	9
2.4 BLOCK DIGRAM SHOWING THE CONFIGURATION OF SYSTEM TESTED	10
2.5 DESCRIPTION OF NECESSARY ACCESSORIES AND SUPPORT UNITS	11
2.6 EQUIPMENTS LIST FOR ALL TEST ITEMS	12
<b>3. EMC EMISSION TEST</b>	<b>13</b>
3.1 CONDUCTED EMISSION MEASUREMENT	13
3.2 RADIATED EMISSION MEASUREMENT	17
<b>4. BANDWIDTH TEST</b>	<b>31</b>
4.1 TEST PROCEDURE	31
4.2 TEST SETUP	31
4.3 EUT OPERATION CONDITIONS	31
4.4 TEST RESULTS	32
<b>5. ANTENNA REQUIREMENT</b>	<b>34</b>
5.1 STANDARD REQUIREMENT	34
5.2 EUT ANTENNA	34
<b>APPENDIX- PHOTOS OF TEST SETUP</b>	<b>35</b>



**Revision History**

Rev.	Issue Date	Report NO.	Effect Page	Contents
00	08 Nov. 2022	STS2210073W01	ALL	Initial Issue





## 1. SUMMARY OF TEST RESULTS

Test procedures according to the technical standards:

<b>FCC Part 15.249 , Subpart C</b>			
Standard Section	Test Item	Judgment	Remark
15.207	Conducted Emission	Pass	
15.203	Antenna Requirement	Pass	
15.249	Radiated Spurious Emission	Pass	
15.249	Radiated Band Edge Emission	Pass	
15.249	Field Strength of fundamental	Pass	
15.215(c)	20dB Bandwidth	Pass	

**NOTE:**

- (1) 'N/A' denotes test is not applicable in this Test Report.
- (2) All tests are according to ANSI C63.10-2013.

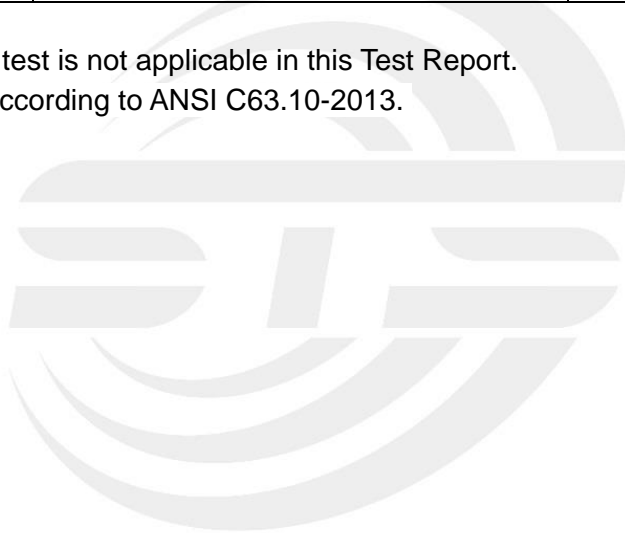



### 1.1 TEST FACTORY

SHENZHEN STS TEST SERVICES CO., LTD

Add. : A 1/F, Building B, Zhuoke Science Park, No.190 Chongqing Road, HepingShequ, Fuyong Sub-District, Bao'an District, Shenzhen, Guang Dong, China

FCC test Firm Registration Number: 625569

IC test Firm Registration Number: 12108A

A2LA Certificate No.: 4338.01

### 1.2 MEASUREMENT UNCERTAINTY

The reported uncertainty of measurement  $y \pm U$ , where expanded uncertainty  $U$  is based on a standard uncertainty multiplied by a coverage factor of  $k=2$ , providing a level of confidence of approximately **95 %**.

No.	Item	Uncertainty
1	RF output power, conducted	$\pm 0.87\text{dB}$
2	Unwanted Emissions, conducted	$\pm 2.895\text{dB}$
3	All emissions, radiated 9K-30MHz	$\pm 3.80\text{dB}$
4	All emissions, radiated 30M-1GHz	$\pm 4.09\text{dB}$
5	All emissions, radiated 1G-6GHz	$\pm 4.92\text{dB}$
6	All emissions, radiated >6G	$\pm 5.49\text{dB}$
7	Conducted Emission (9KHz-30MHz)	$\pm 2.73\text{dB}$



## 2. GENERAL INFORMATION

### 2.1 GENERAL DESCRIPTION OF THE EUT

Product Name	MoveLink Mini 2.4GHz Wireless Microphone System (Transmitter)								
Brand	Godox								
Model Number	MoveLink Mini TX								
Series Model(s)	N/A								
Model Difference	N/A								
Product Description	<p>The EUT is a MoveLink Mini 2.4GHz Wireless Microphone System (Transmitter)</p> <table border="1"><tr><td>Operation Frequency:</td><td>2402~2480 MHz</td></tr><tr><td>Modulation Type:</td><td>GFSK</td></tr><tr><td>Antenna Designation:</td><td>Please refer to the Note 3.</td></tr><tr><td>Antenna Gain(Peak):</td><td>0.45dBi</td></tr></table> <p>Based on the application, features, or specification exhibited in User Manual, the EUT is considered as an ITE/Computing Device. More details of EUT technical specification, please refer to the User Manual.</p>	Operation Frequency:	2402~2480 MHz	Modulation Type:	GFSK	Antenna Designation:	Please refer to the Note 3.	Antenna Gain(Peak):	0.45dBi
Operation Frequency:	2402~2480 MHz								
Modulation Type:	GFSK								
Antenna Designation:	Please refer to the Note 3.								
Antenna Gain(Peak):	0.45dBi								
Channel List	Please refer to the Note 2.								
Rating	Input: DC 5V 80mA, Built-in Li-ion battery: DC 3.7 V, 100mAh								
Hardware version number	20220511H32								
Software version number	V1.0								
Connecting I/O Port(s)	Please refer to the Note 1.								

Note:

1. For a more detailed features description, please refer to the manufacturer's specifications or the User Manual.



2.

Channel List					
Channel	Frequency (MHz)	Channel	Frequency (MHz)	Channel	Frequency (MHz)
01	2402	28	2429	55	2456
02	2403	29	2430	56	2457
03	2404	30	2431	57	2458
04	2405	31	2432	58	2459
05	2406	32	2433	59	2460
06	2407	33	2434	60	2461
07	2408	34	2435	61	2462
08	2409	35	2436	62	2463
09	2410	36	2437	63	2464
10	2411	37	2438	64	2465
11	2412	38	2439	65	2466
12	2413	39	2440	66	2467
13	2414	40	2441	67	2468
14	2415	41	2442	68	2469
15	2416	42	2443	69	2470
16	2417	43	2444	70	2471
17	2418	44	2445	71	2472
18	2419	45	2446	72	2473
19	2420	46	2447	73	2474
20	2421	47	2448	74	2475
21	2422	48	2449	75	2476
22	2423	49	2450	76	2477
23	2424	50	2451	77	2478
24	2425	51	2452	78	2479
25	2426	52	2453	79	2480
26	2427	53	2454		
27	2428	54	2455		

3. Table for Filed Antenna

Ant	Brand	Model Name	Antenna Type	Connector	Gain (dBi)	NOTE
1	Godox	MoveLink Mini TX	PCB	N/A	0.45dBi	Antenna

Note: The antenna information refer the manufacturer provide report, applicable only to the tested sample identified in the report.





## 2.2 DESCRIPTION OF THE TEST MODES

For conducted test items and radiated spurious emissions

Each of these EUT operation mode(s) or test configuration mode(s) mentioned below was evaluated respectively.

Pretest Mode	Description	Data/Modulation
Mode 1	TX Low channel	GFSK
Mode 2	TX Mid channel	GFSK
Mode 3	TX High channel	GFSK

Note:

(1) All above mode have been measurement, only worst data was reported.

(2) We have be tested for all avaiable U.S. voltage and frequencies(For 120V,50/60Hz and 240V, 50/60Hz) for which the device is capable of operation, and the worst case of 120V,50/60Hz is shown in the report.

For AC Conducted Emission

Test Case	
AC Conducted Emission	Mode 4 : Keeping TX

## 2.3 TEST SOFTWARE AND POWER LEVEL

During testing channel & power controlling software provided by the customer was used to control the operating channel as well as the output power level.

RF Function	Type	Mode Or Modulation type	ANT Gain(dBi)	Power Class	Software For Testing
Other SRD	2.4G	GFSK	0.45	Default	FCC_Test_Tools_V2.24

## 2.4 BLOCK DIGRAM SHOWING THE CONFIGURATION OF SYSTEM TESTED

During testing channel & power controlling software provided by the customer was used to control the operating channel as well as the output power level. The RF output power selection is for the setting of RF output power expected by the customer and is going to be fixed on the firmware of the final end product power parameters.

### Radiated Spurious Emission Test

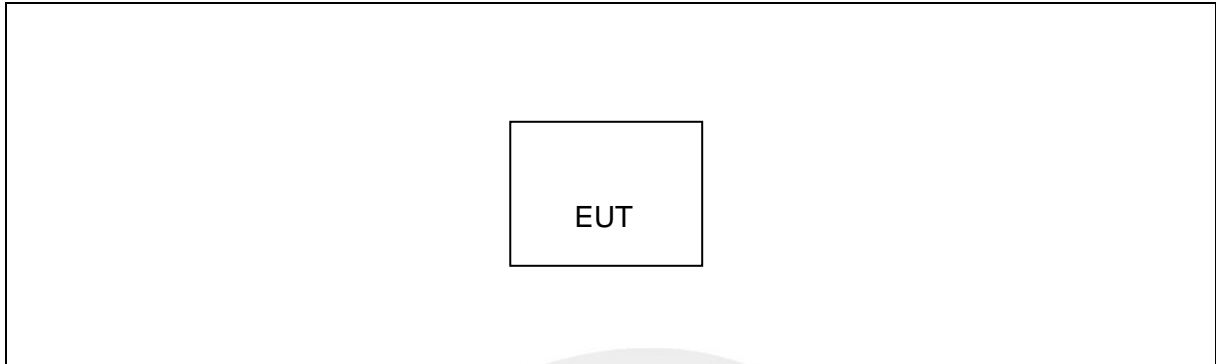

### Conducted Emission Test

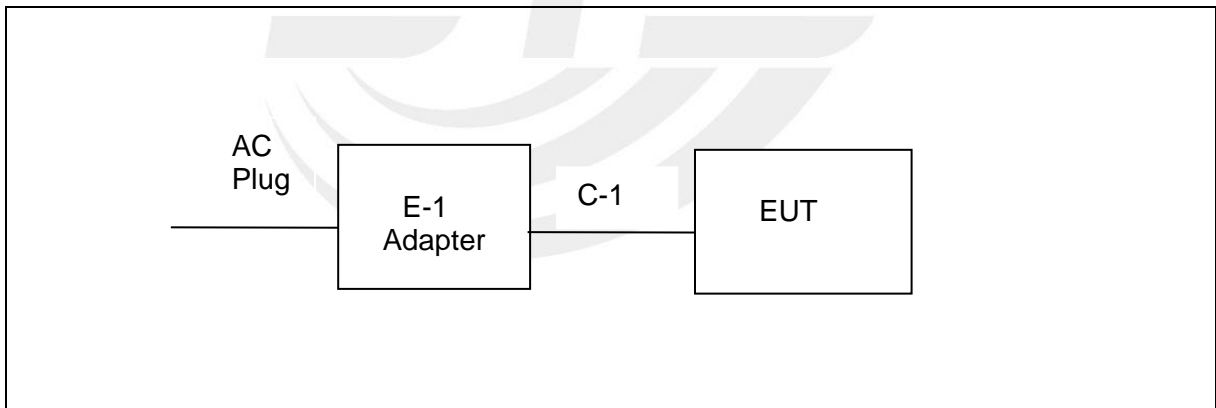



## 2.5 DESCRIPTION OF NECESSARY ACCESSORIES AND SUPPORT UNITS

The EUT has been tested as an independent unit together with other necessary accessories or support units. The following support units or accessories were used to form a representative test configuration during the tests.

### Necessary accessories

Item	Equipment	Mfr/Brand	Model/Type No.	Length	Note
C-1	USB Cable	N/A	N/A	38cm	NO

### Support units

Item	Equipment	Mfr/Brand	Model/Type No.	Length	Note
E-1	Adapter	HUAWEI	HW-050450C00	N/A	N/A

#### Note:

- (1) The support equipment was authorized by Declaration of Confirmation.
- (2) For detachable type I/O cable should be specified the length in cm in 『Length』 column.



2.6 EQUIPMENTS LIST FOR ALL TEST ITEMS

RF Radiation Test Equipment					
Kind of Equipment	Manufacturer	Type No.	Serial No.	Last Calibration	Calibrated Until
Temperature & Humidity	SW-108	SuWei	N/A	2022.03.02	2023.03.01
Pre-Amplifier(0.1M-3GHz)	EM	EM330	060665	2022.07.04	2023.07.03
Pre-Amplifier (1G-18GHz)	SKET	LNPA-01018G-45	SK2018080901	2022.09.29	2023.09.28
Pre-mpifier(18G-40G)	SKET	LNPA_1840-50	SK2018101801	2022.07.23	2023.07.22
Positioning Controller	MF	MF-7802	MF-780208587	N/A	N/A
Signal Analyzer	R&S	FSV 40-N	101823	2022.09.29	2023.09.28
Switch Control Box	N/A	N/A	N/A	N/A	N/A
Filter Box	BALUN Technology	SU319E	BL-SZ1530051	N/A	N/A
Active loop Antenna	ZHINAN	ZN30900C	16035	2022.03.02	2023.03.01
Bilog Antenna	TESEQ	CBL6111D	34678	2022.09.30	2024.09.29
Horn Antenna	SCHWARZBECK	BBHA 9120D	02014	2021.10.11	2023.10.10
Horn Antenna	A-INFOMW	LB-180400-KF	J211020657	2021.09.28	2023.09.27
Antenna Mast	MF	MFA-440H	N/A	N/A	N/A
Turn Table	MF	SC100_1	60531	N/A	N/A
AC Power Source	APC	KDF-11010G	F214050035	N/A	N/A
DC Power Supply	Zhaoxin	RXN 605D	20R605D11010081	N/A	N/A
Test SW	EZ-EMC	Ver.STSLAB-03A1 RE			
Conduction Test equipment					
Kind of Equipment	Manufacturer	Type No.	Serial No.	Last calibration	Calibrated until
Test Receiver	R&S	ESCI	101427	2022.09.29	2023.09.28
LISN	R&S	ENV216	101242	2022.09.28	2023.09.27
LISN	EMCO	3810/2NM	23625	2022.09.28	2023.09.27
Temperature & Humidity	HH660	Mieo	N/A	2022.09.30	2023.09.29
Test SW	EZ-EMC	Ver.STSLAB-03A1 CE			
RF Connected Test					
Kind of Equipment	Manufacturer	Type No.	Serial No.	Last calibration	Calibrated until
Signal Analyzer	Agilent	N9020A	MY51510623	2022.03.01	2023.02.28
Switch control box	MW	MW100-RFCB	N/A	N/A	N/A
Temperature & Humidity	HH660	Mieo	N/A	2022.09.30	2023.09.29
Test SW	MW	MTS 8310_2.0.0.0			

### 3. EMC EMISSION TEST

#### 3.1 CONDUCTED EMISSION MEASUREMENT

##### 3.1.1 POWER LINE CONDUCTED EMISSION LIMITS

Operating frequency band. In case the emission fall within the restricted band specified on Part 15.249 limit in the table below has to be followed.

FREQUENCY (MHz)	Quasi-peak	Average
0.15 -0.5	66 - 56 *	56 - 46 *
0.50 -5.0	56.00	46.00
5.0 -30.0	60.00	50.00

Note:

- (1) The tighter limit applies at the band edges.
- (2) The limit of “ \* ” marked band means the limitation decreases linearly with the logarithm of the frequency in the range.

The following table is the setting of the receiver

Receiver Parameters	Setting
Attenuation	10 dB
Start Frequency	0.15 MHz
Stop Frequency	30 MHz
IF Bandwidth	9 kHz

### 3.1.2 TEST PROCEDURE

- a. The EUT was 0.8 meters from the horizontal ground plane and 0.4 meters from the vertical ground plane with EUT being connected to the power mains through a line impedance stabilization network (LISN). All other support equipments powered from additional LISN(s). The LISN provide 50 Ohm/ 50uH of coupling impedance for the measuring instrument.
- b. Interconnecting cables that hang closer than 40 cm to the ground plane shall be folded back and forth in the center forming a bundle 30 to 40 cm long.
- c. I/O cables that are not connected to a peripheral shall be bundled in the center. The end of the cable may be terminated, if required, using the correct terminating impedance. The overall length shall not exceed 1 m.
- d. LISN at least 80 cm from nearest part of EUT chassis.
- e. For the actual test configuration, please refer to the related Item –EUT Test Photos.

### 3.1.3 TEST SETUP

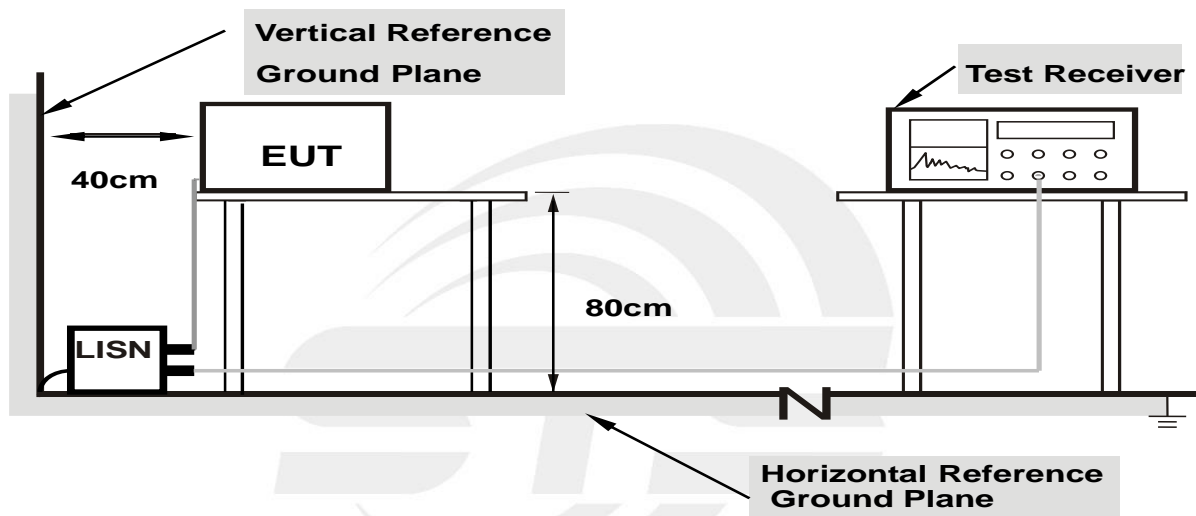

- Note: 1.Support units were connected to second LISN.**  
**2.Both of LISNs (AMN) are 80 cm from EUT and at least 80 from other units and other metal planes**

### 3.1.4 EUT OPERATING CONDITIONS

The EUT was configured for testing in a typical fashion (as a customer would normally use it). The EUT has been programmed to continuously transmit during test. This operating condition was tested and used to collect the included data.



3.1.5 TEST RESULT

Temperature:	26.2(C)	Relative Humidity:	48%RH
Test Voltage:	AC 120V/60Hz	Phase:	L
Test Mode:	Mode 4		

No.	Frequency (MHz)	Reading (dBuV)	Correct Factor(dB)	Result (dBuV)	Limit (dBuV)	Margin (dB)	Remark
1	0.1500	45.15	10.33	55.48	66.00	-10.52	QP
2	0.1500	26.71	10.33	37.04	56.00	-18.96	AVG
3	0.1900	43.07	10.31	53.38	64.04	-10.66	QP
4	0.1900	29.92	10.31	40.23	54.04	-13.81	AVG
5	0.2860	42.99	10.69	53.68	60.64	-6.96	QP
6	0.2860	28.96	10.69	39.65	50.64	-10.99	AVG
7	0.3620	42.16	10.62	52.78	58.68	-5.90	QP
8	0.3620	28.00	10.62	38.62	48.68	-10.06	AVG
9	0.4260	40.61	10.54	51.15	57.33	-6.18	QP
10	0.4260	29.18	10.54	39.72	47.33	-7.61	AVG
11	9.2420	38.60	11.04	49.64	60.00	-10.36	QP
12	9.2420	22.34	11.04	33.38	50.00	-16.62	AVG

Remark:

1. All readings are Quasi-Peak and Average values.
2. Margin = Result (Result =Reading + Factor )–Limit

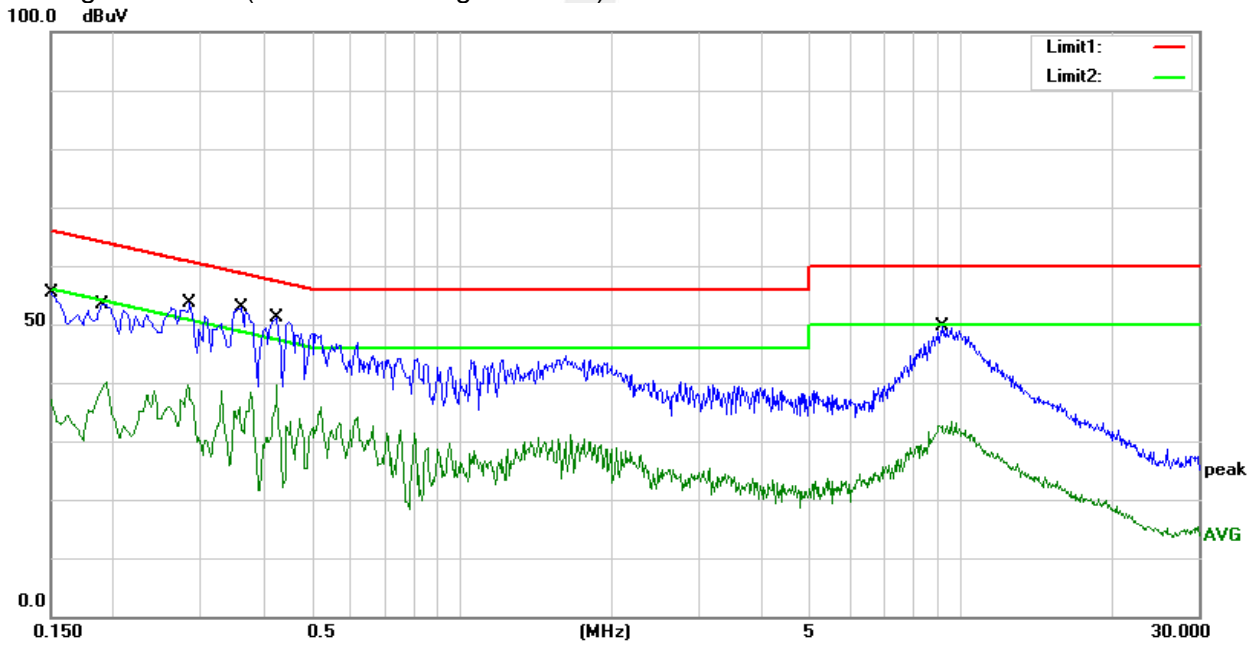



Temperature:	26.2(C)	Relative Humidity:	48%RH
Test Voltage:	AC 120V/60Hz	Phase:	N
Test Mode:	Mode 4		

No.	Frequency (MHz)	Reading (dBuV)	Correct Factor(dB)	Result (dBuV)	Limit (dBuV)	Margin (dB)	Remark
1	0.1500	44.69	10.29	54.98	66.00	-11.02	QP
2	0.1500	26.16	10.29	36.45	56.00	-19.55	AVG
3	0.1900	43.14	10.38	53.52	64.04	-10.52	QP
4	0.1900	31.41	10.38	41.79	54.04	-12.25	AVG
5	0.2860	43.08	10.73	53.81	60.64	-6.83	QP
6	0.2860	30.97	10.73	41.70	50.64	-8.94	AVG
7	0.3620	42.32	10.65	52.97	58.68	-5.71	QP
8	0.3620	28.66	10.65	39.31	48.68	-9.37	AVG
9	0.4260	40.69	10.55	51.24	57.33	-6.09	QP
10	0.4260	29.86	10.55	40.41	47.33	-6.92	AVG
11	9.6340	37.93	10.88	48.81	60.00	-11.19	QP
12	9.6340	21.88	10.88	32.76	50.00	-17.24	AVG

Remark:

1. All readings are Quasi-Peak and Average values.
2. Margin = Result (Result =Reading + Factor )–Limit

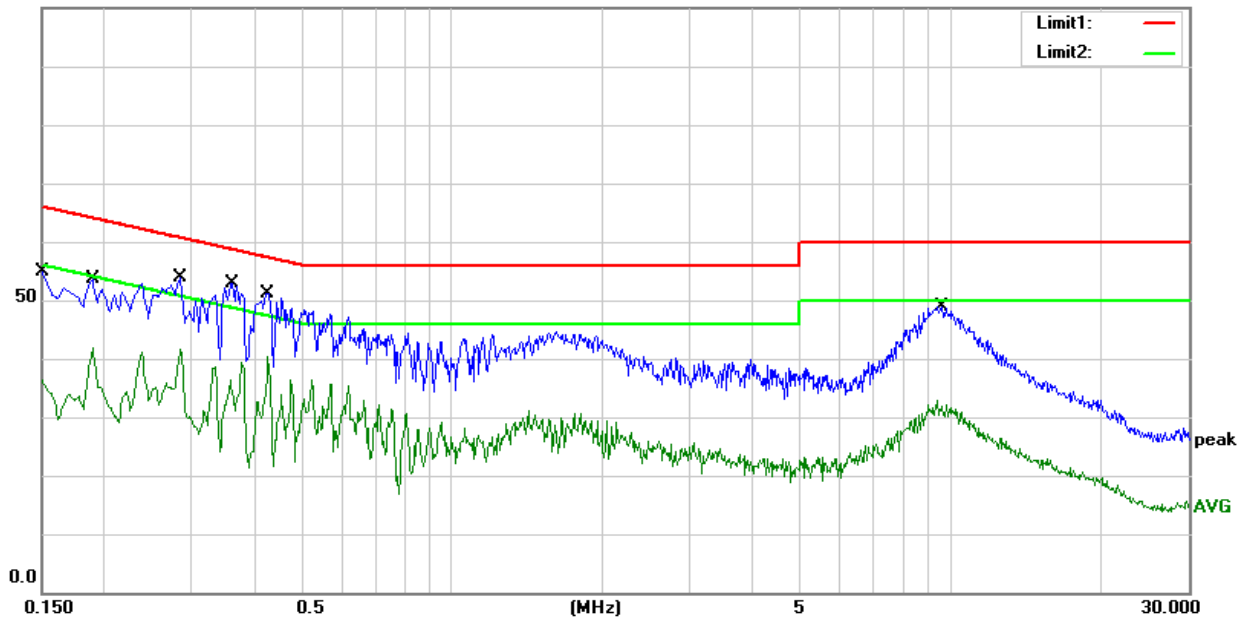





### 3.2 RADIATED EMISSION MEASUREMENT

#### 3.2.1 RADIATED EMISSION LIMITS

20dBc in any 100 kHz bandwidth outside the operating frequency band. In case the emission fall within the restricted band specified on Part 15.249 and the Part 15.209(a) limit in the table below has to be followed.

Standard FCC 15.209

Frequencies (MHz)	Field Strength (micorvolts/meter)	Measurement Distance (meters)
0.009~0.490	2400/F(KHz)	300
0.490~1.705	24000/F(KHz)	30
1.705~30.0	30	30
30~88	100	3
88~216	150	3
216~960	200	3
960~1000	500	3
Above 1000	Other:74.0 dB( $\mu$ V)/m (Peak) 54.0 dB( $\mu$ V)/m (Average)	3

Standard FCC 15.249

Frequency of Emission (MHz)	Field Strength of fundamental (millivolts /meter)	Field Strength of Harmonics (microvolts/meter)
900~928	50	500
2400~2483.5	50	500
5725~5875	50	500
24000~242500	250	2500

Notes:

- (1) Emissions radiated outside of the specified frequency bands, except for harmonics, shall be attenuated by at least 50 dB below the level of the fundamental or to the general radiated emission limits in Section 15.209, whichever is the lesser attenuation.

Spectrum Parameter	Setting
Detector	Peak/AV
Attenuation	Auto
Start Frequency	1000 MHz
Stop Frequency	10th carrier harmonic
RB (emission in restricted band)	>20BW
VB (emission in restricted band)	=3xRB



Receiver Parameter	Setting
Attenuation	Auto
Start ~ Stop Frequency	9kHz~90kHz / RB 200Hz for PK & AV
	90kHz~110kHz / RB 200Hz for QP
	110kHz~490kHz / RB 200Hz for PK & AV
	490kHz~30MHz / RB 9kHz for QP
	30MHz~1000MHz / RB 120kHz for QP

### 3.2.2 TEST PROCEDURE

- a. The measuring distance of 3m shall be used for measurements. The EUT was placed on the top of a rotating table 0.8 meter above the ground at a 3 meter semi-anechoic chamber. The table was rotated 360 degrees to determine the position of the highest radiation (Below 1GHz)
- b. The measuring distance of 3m shall be used for measurements. The EUT was placed on the top of a rotating table 1.5 meter above the ground at a 3 meter semi-anechoic chamber. The table was rotated 360 degrees to determine the position of the highest radiation (Above 1GHz)
- c. The height of the test antenna shall vary between 1m to 4m. Both horizontal and vertical polarization of the antenna are set to make the measurement.
- d. The initial step in collecting radiated emission data is a receive peak detector mode. Pre-scanning the measurement frequency range. Significant peaks are then marked and then Quasi Peak detector mode re-measured.
- e. All readings are peak unless otherwise stated QP in column of Note. Peak denoted that the Peak reading compliance with the QP limits and then QP Mode measurement didn't perform (Below 1GHz)
- f. All readings are Peak mode value unless otherwise stated AVG in column of Note. If the Peak mode measured value compliance with the Peak limits and lower than AVG Limits, the EUT shall be deemed to meet Peak & AVG limits and then only Peak mode was measured, but AVG mode didn't perform. (Above 1GHz)
- g. For the actual test configuration, please refer to the related Item –EUT Test Photos.  
Note: Both horizontal and vertical antenna polarities were tested and performed pretest to three orthogonal axis. The worst case emissions were reported.

### 3.2.3 DEVIATION FROM TEST STANDARD

No deviation

### 3.2.4 TEST SETUP

#### (A) Radiated Emission Test-Up Frequency Below 30MHz

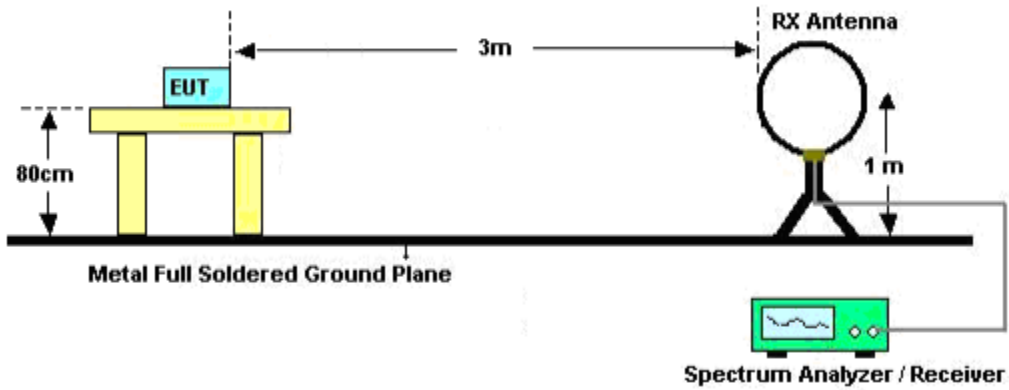

#### (B) Radiated Emission Test-Up Frequency 30MHz~1GHz

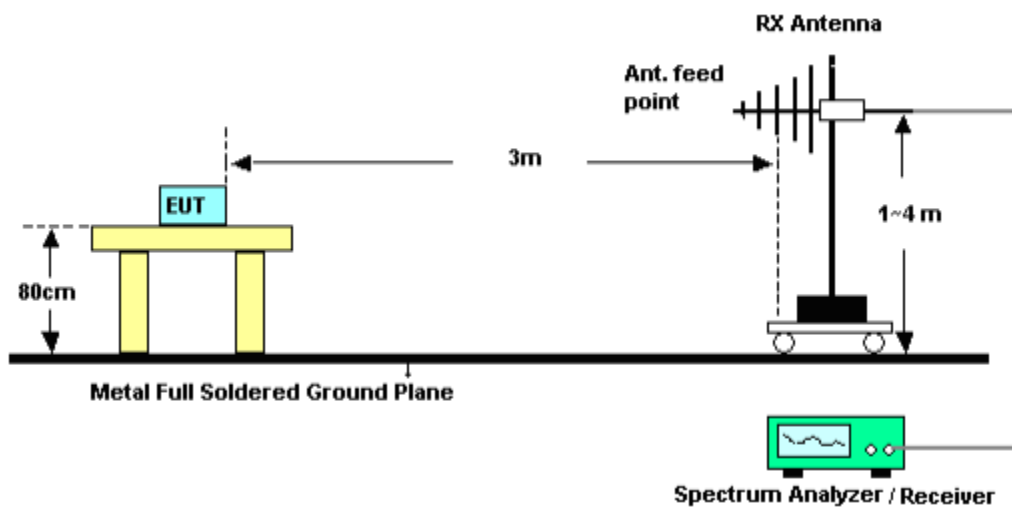

#### (C) Radiated Emission Test-Up Frequency Above 1GHz

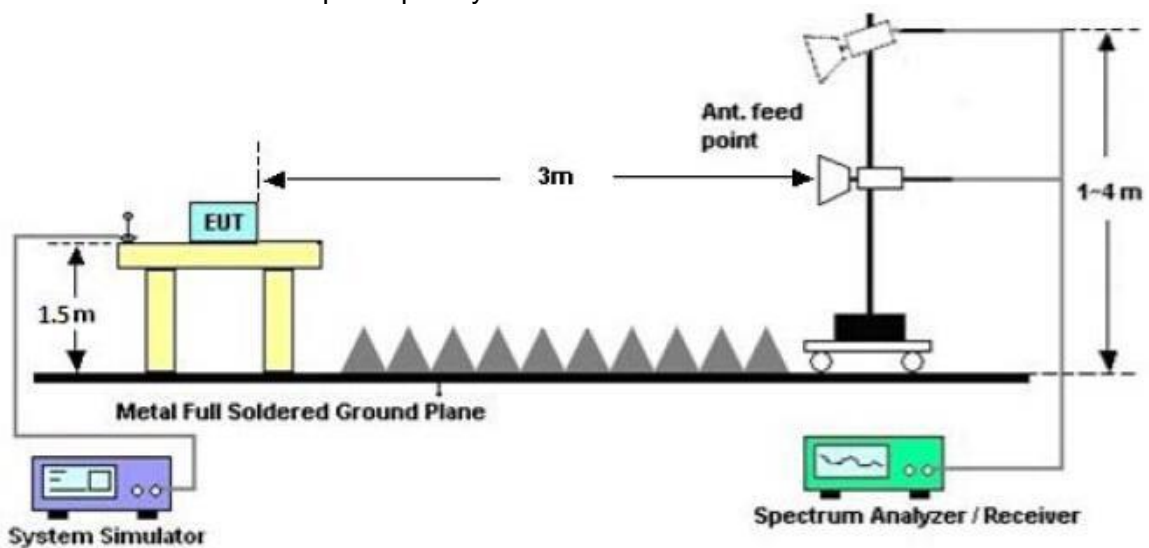



### 3.2.5 FIELD STRENGTH CALCULATION

The field strength is calculated by adding the Antenna Factor and Cable Factor and subtracting the Amplifier Gain and Duty Cycle Correction Factor (if any) from the measured reading. The basic equation with a sample calculation is as follows:

Margin=PL-PK L or AL- AV L; Margin only shown the worst case.

Where

PR = Peak Reading

AR = Average Reading

PL = Peak Level

AL = Average Level

AF = Antenna Factor

PK L = Peak Limit

AV L = AV Limit

For example

Frequency	PR	AR	AF	PL	AL	PK L	AV L	Margin
(MHz)	(dB $\mu$ V/m)	(dB $\mu$ V/m)	(dB)	(dB $\mu$ V/m)	(dB $\mu$ V/m)	(dB $\mu$ V/m)	(dB $\mu$ V/m)	(dB)
2178	40.23	30.31	9.83	50.06	40.14	74.00	54.00	-13.86





### 3.2.6 EUT OPERATING CONDITIONS

The EUT tested system was configured as the statements of 2.4 Unless otherwise a special operating condition is specified in the follows during the testing.

Below 30 MHz

Temperature:	23.1(C)	Relative Humidity:	60%RH
Test Voltage:	DC 5V	Polarization:	---
Test Mode:	TX Mode		

Freq. (MHz)	Reading (dBuV/m)	Limit (dBuV/m)	Margin (dB)	State P/F
--	--	--	--	PASS
--	--	--	--	PASS

**NOTE:**

The amplitude of spurious emissions which are attenuated by more than 20dB below the permissible value has no need to be reported.

Distance extrapolation factor =  $40 \log (\text{specific distance}/\text{test distance})$ (dB);

Limit line = specific limits(dBuv) + distance extrapolation factor.

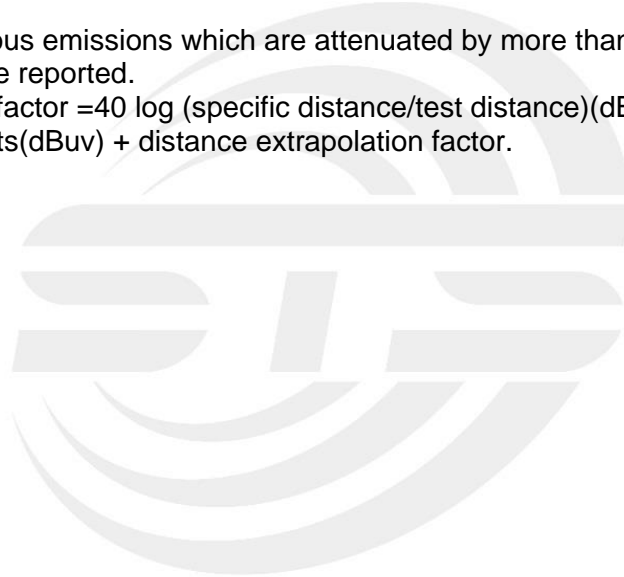



Between 30MHz – 1000 MHz Radiation Spurious

Temperature:	23.1(C)	Relative Humidity:	60%RH
Test Voltage:	DC 5V	Phase:	Horizontal
Test Mode:	Mode 1/2/3 (Mode 1 worst mode)		

No.	Frequency (MHz)	Reading (dBuV)	Correct Factor(dB/m)	Result (dBuV/m)	Limit (dBuV/m)	Margin (dB)	Remark
1	115.3600	54.33	-18.55	35.78	43.50	-7.72	peak
2	256.9800	51.02	-15.13	35.89	46.00	-10.11	peak
3	528.5800	45.71	-7.51	38.20	46.00	-7.80	peak
4	696.3900	41.04	-4.23	36.81	46.00	-9.19	peak
5	800.1800	39.66	-2.05	37.61	46.00	-8.39	peak
6	1000.0000	39.54	2.04	41.58	54.00	-12.42	peak

Remark:

1. Margin = Result (Result =Reading + Factor )–Limit

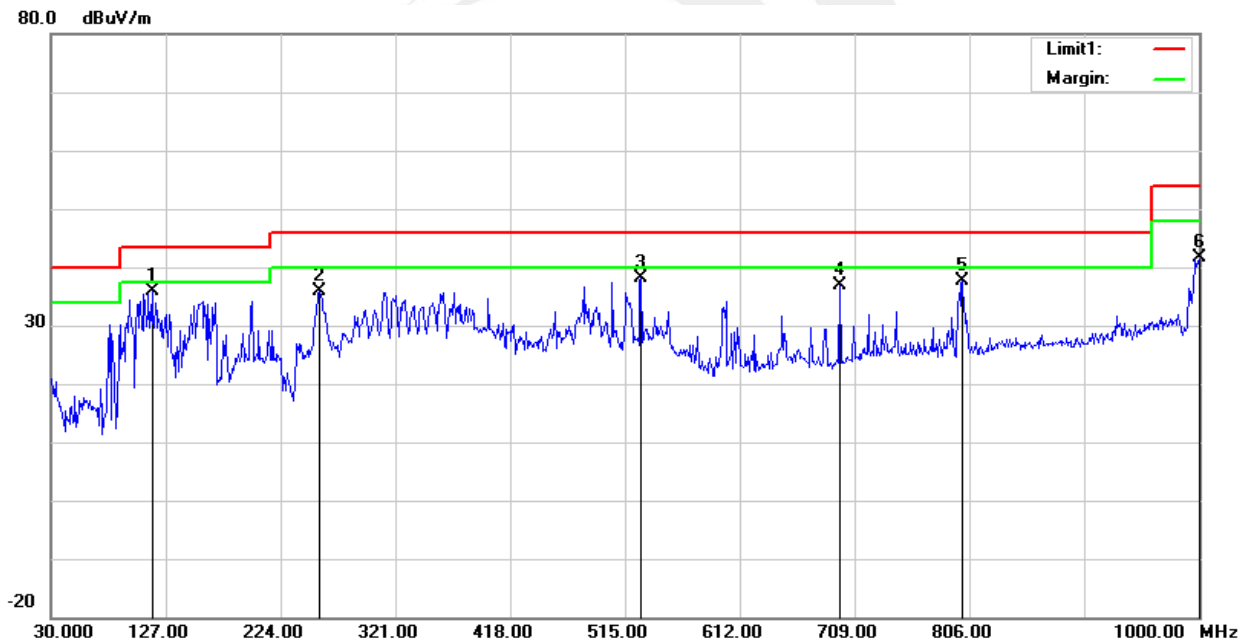



Temperature:	23.1(C)	Relative Humidity:	60%RH
Test Voltage:	DC 5V	Phase:	Vertical
Test Mode:	Mode 1/2/3 (Mode 1 worst mode)		

No.	Frequency (MHz)	Reading (dBuV)	Correct Factor(dB/m)	Result (dBuV/m)	Limit (dBuV/m)	Margin (dB)	Remark
1	107.6000	54.20	-19.32	34.88	43.50	-8.62	peak
2	258.9200	50.93	-14.90	36.03	46.00	-9.97	peak
3	452.9200	46.85	-9.61	37.24	46.00	-8.76	peak
4	696.3900	36.82	-4.23	32.59	46.00	-13.41	peak
5	868.0800	30.53	-0.51	30.02	46.00	-15.98	peak
6	998.0600	31.08	2.04	33.12	54.00	-20.88	peak

Remark:

1. Margin = Result (Result =Reading + Factor )–Limit

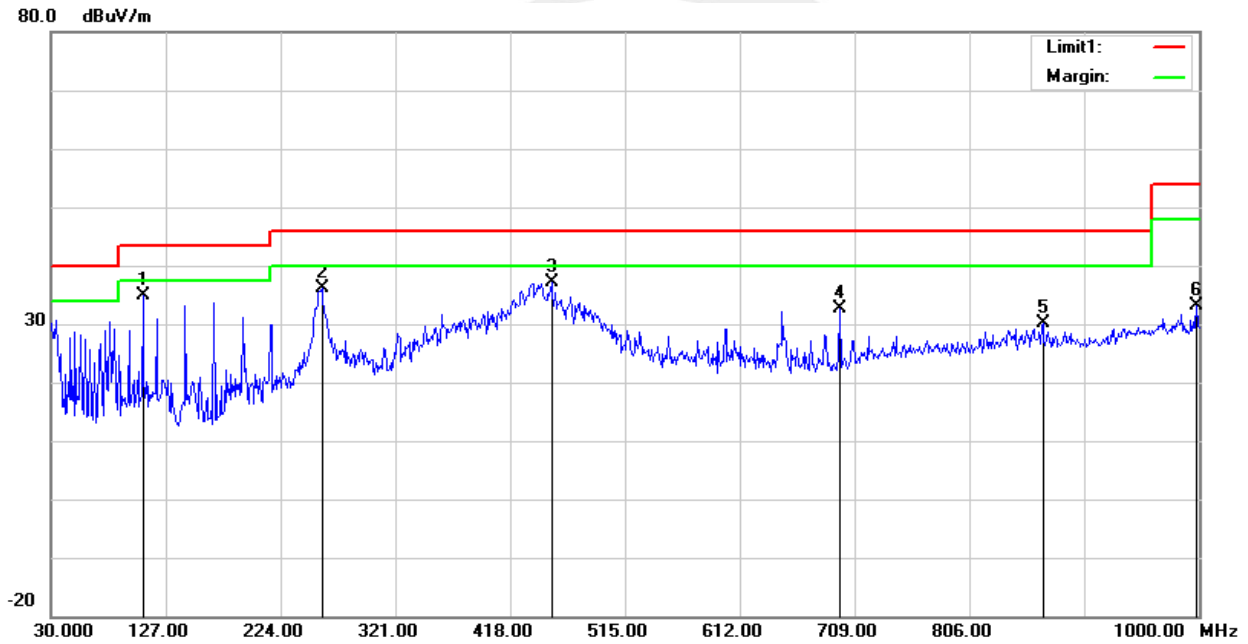



Above 1G Radiation Spurious

**PK**  
**2402 MHz**

Frequency (MHz)	Meter Reading (dB $\mu$ V/m)	Detector (PK/QP/AV)	Amplifier (dB)	Loss (dB)	Antenna Factor (dB/m)	Orrected Factor (dB)	Corrected Amplitude (dB $\mu$ V/m)	FCC Part 15.249/15.209/205		RX Antenna
								Limit (dB $\mu$ V/m)	Margin (dB)	Polar (H/V)
4803.94	60.00	PK	50.33	8.84	31.22	-10.27	49.73	74	-24.27	H
4803.94	59.06	PK	50.33	8.84	31.22	-10.27	48.79	74	-25.21	V
7205.98	56.88	PK	55.48	9.31	34.05	-12.12	44.76	74	-29.24	H
7205.98	55.50	PK	55.48	9.31	34.05	-12.12	43.38	74	-30.62	V
9608.11	60.19	PK	59.13	9.89	36.99	-12.25	47.94	74	-26.06	H
9608.11	59.07	PK	59.13	9.89	36.99	-12.25	46.82	74	-27.18	V

**2440 MHz**

Frequency (MHz)	Meter Reading (dB $\mu$ V/m)	Detector (PK/QP/AV)	Amplifier (dB)	Loss (dB)	Antenna Factor (dB/m)	Orrected Factor (dB)	Corrected Amplitude (dB $\mu$ V/m)	FCC Part 15.249/15.209/205		RX Antenna
								Limit (dB $\mu$ V/m)	Margin (dB)	Polar (H/V)
4880.11	59.80	PK	50.33	8.84	31.22	-10.27	49.53	74	-24.47	H
4880.11	59.42	PK	50.33	8.84	31.22	-10.27	49.15	74	-24.85	V
7320.02	56.83	PK	55.48	9.31	34.05	-12.12	44.71	74	-29.29	H
7320.02	55.60	PK	55.48	9.31	34.05	-12.12	43.48	74	-30.52	V
9760.14	60.22	PK	59.13	9.89	36.99	-12.25	47.97	74	-26.03	H
9760.14	58.71	PK	59.13	9.89	36.99	-12.25	46.46	74	-27.54	V

**2480 MHz**

Frequency (MHz)	Meter Reading (dB $\mu$ V/m)	Detector (PK/QP/AV)	Amplifier (dB)	Loss (dB)	Antenna Factor (dB/m)	Orrected Factor (dB)	Corrected Amplitude (dB $\mu$ V/m)	FCC Part 15.249/15.209/205		RX Antenna
								Limit (dB $\mu$ V/m)	Margin (dB)	Polar (H/V)
4960.12	59.74	PK	50.33	8.84	31.22	-10.27	49.47	74	-24.53	H
4960.12	59.05	PK	50.33	8.84	31.22	-10.27	48.78	74	-25.22	V
7440.04	57.18	PK	55.48	9.31	34.05	-12.12	45.06	74	-28.94	H
7440.04	55.78	PK	55.48	9.31	34.05	-12.12	43.66	74	-30.34	V
9920.03	60.21	PK	59.13	9.89	36.99	-12.25	47.96	74	-26.04	H
9920.03	59.23	PK	59.13	9.89	36.99	-12.25	46.98	74	-27.02	V

The peak value is less than the AV limit, so AV data does not need to be tested.





Duty cycle

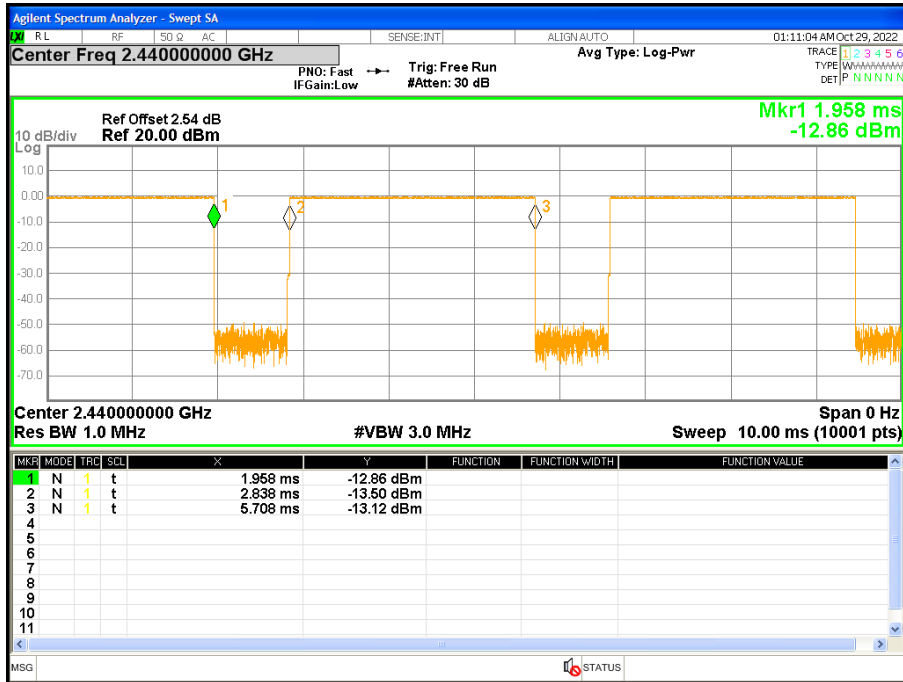

Ton (ms)	Tp (ms)	Duty Factor
2.87	3.75	-2.32

Note: Duty Factor=20\*LOG10(Ton/Tp)



(Radiation Band edge)

**Low channel**  
Horizontal

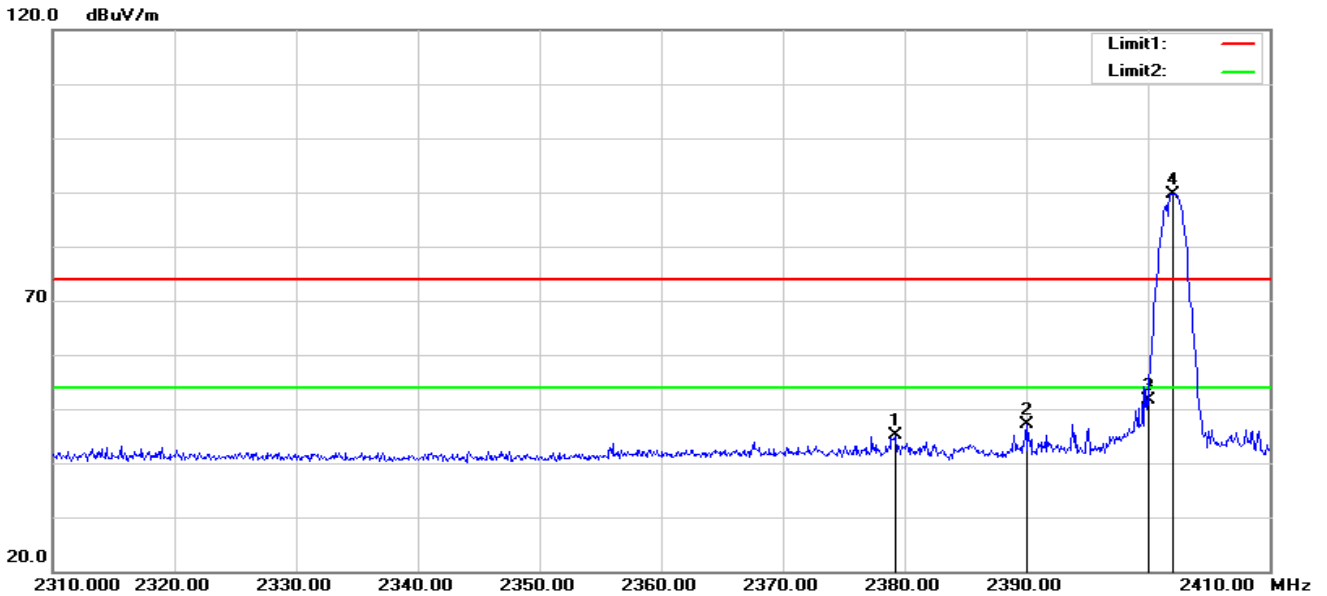

No.	Frequency (MHz)	Reading (dBuV)	Correct Factor(dB/m)	Result (dBuV/m)	Limit (dBuV/m)	Margin (dB)	Remark
1	2379.200	40.95	4.18	45.13	74.00	-28.87	peak
2	2390.000	42.68	4.34	47.02	74.00	-26.98	peak
3	2400.000	47.05	4.49	51.54	74.00	-22.46	peak

**Fundamental Frequency**

No.	Frequency (MHz)	Reading (dBuV)	Correct Factor(dB/m)	Duty cycle Factor(dB/m)	Result (dBuV/m)	Limit (dBuV/m)	Margin (dB)	Remark
4	2402.000	85.25	4.49	-	89.74	114.00	-24.26	peak
4	2402.000	85.25	4.49	-2.32	87.42	94.00	-6.58	AV



Vertical

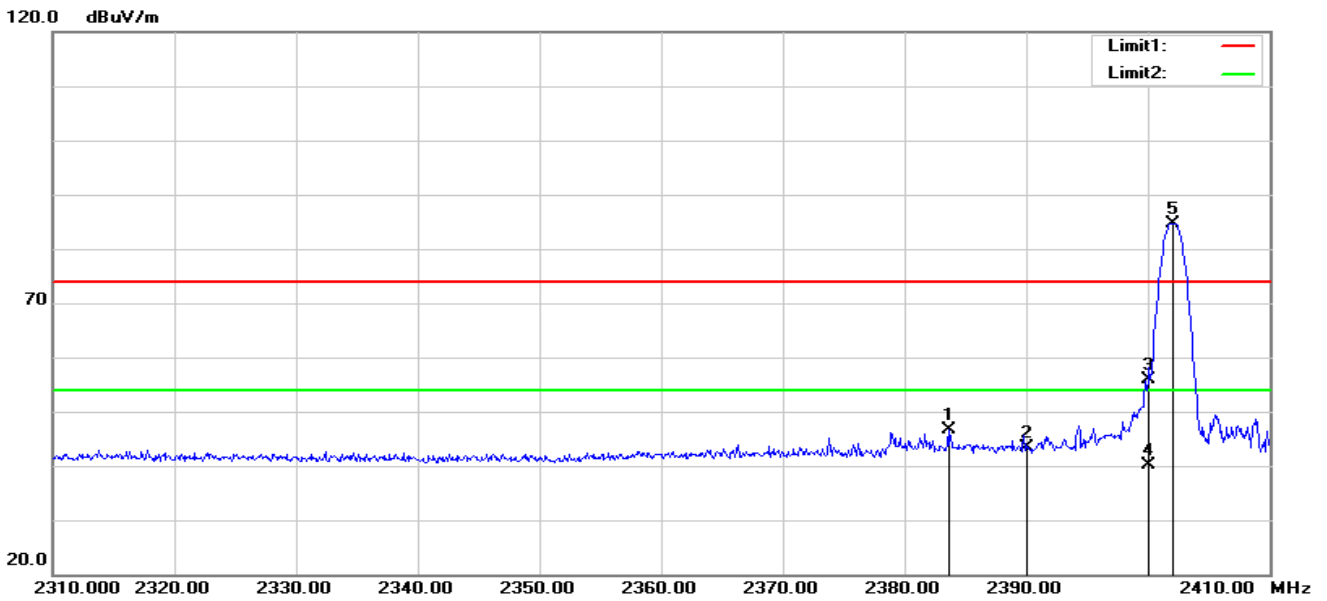

No.	Frequency (MHz)	Reading (dBuV)	Correct Factor(dB/m)	Result (dBuV/m)	Limit (dBuV/m)	Margin (dB)	Remark
1	2383.600	42.47	4.24	46.71	74.00	-27.29	peak
2	2390.000	38.94	4.34	43.28	74.00	-30.72	peak
3	2400.000	51.41	4.49	55.90	74.00	-18.10	peak
4	2400.000	35.72	4.49	40.21	54.00	-13.79	AVG

Fundamental Frequency

No.	Frequency (MHz)	Reading (dBuV)	Correct Factor(dB/m)	Duty cycle Factor(dB/m)	Result (dBuV/m)	Limit (dBuV/m)	Margin (dB)	Remark
5	2402.000	80.13	4.49	-	84.62	114.00	-29.38	peak
5	2402.000	80.13	4.49	-2.32	82.30	94.00	-11.70	AV



Mid channel  
Horizontal

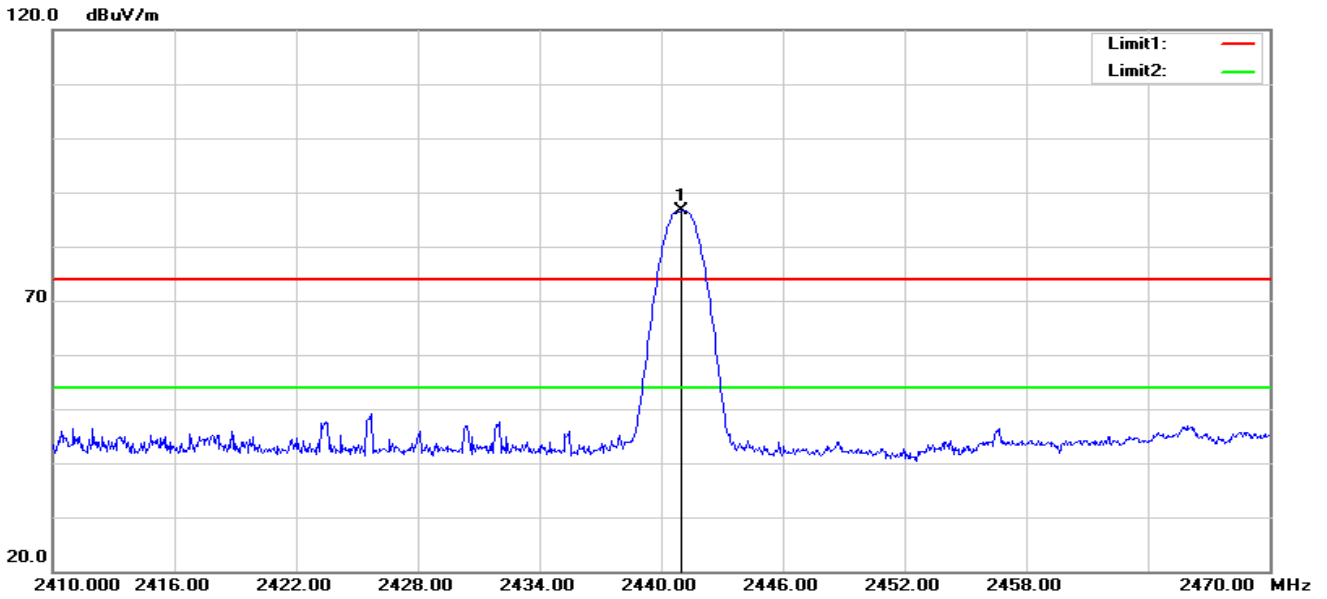

No.	Frequency (MHz)	Reading (dBuV)	Correct Factor(dB/m)	Duty cycle Factor(dB/m)	Result (dBuV/m)	Limit (dBuV/m)	Margin (dB)	Remark
1	2441.000	82.16	4.52	-	86.68	114.00	-27.32	peak
1	2441.000	82.16	4.52	-2.32	84.36	94.00	-9.64	AV

Vertical

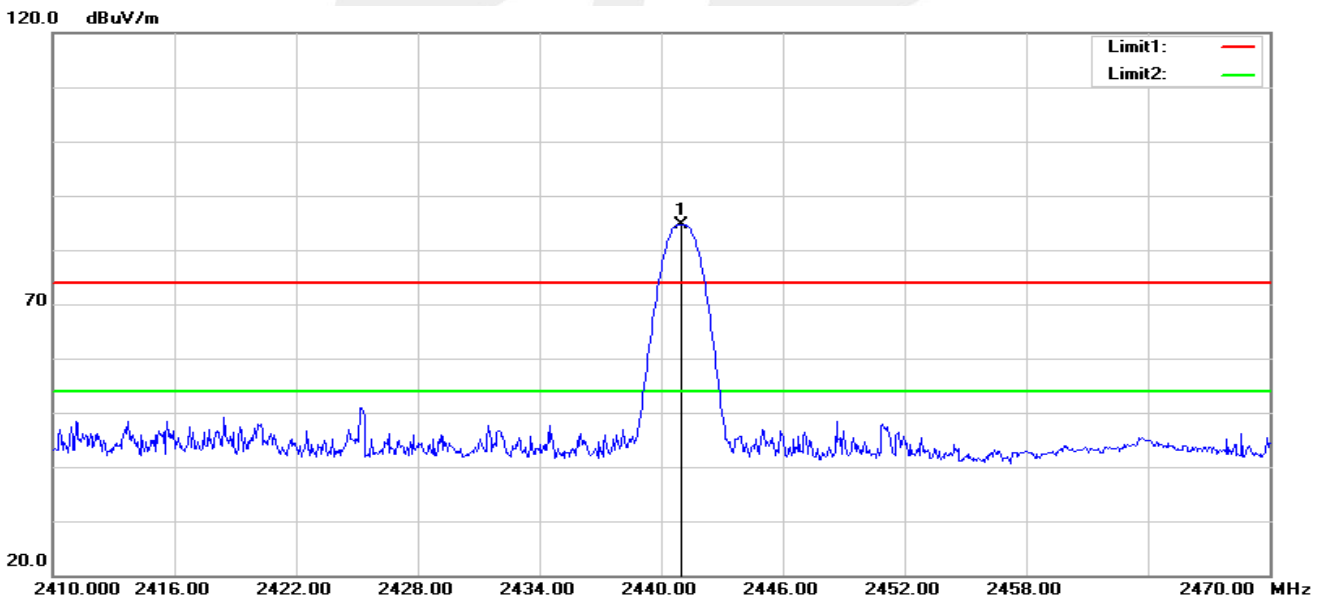

No.	Frequency (MHz)	Reading (dBuV)	Correct Factor(dB/m)	Duty cycle Factor(dB/m)	Result (dBuV/m)	Limit (dBuV/m)	Margin (dB)	Remark
1	2441.000	80.10	4.52	-	84.62	114.00	-29.38	peak
1	2441.000	80.10	4.52	-2.32	82.30	94.00	-11.70	AV



### High channel Horizontal

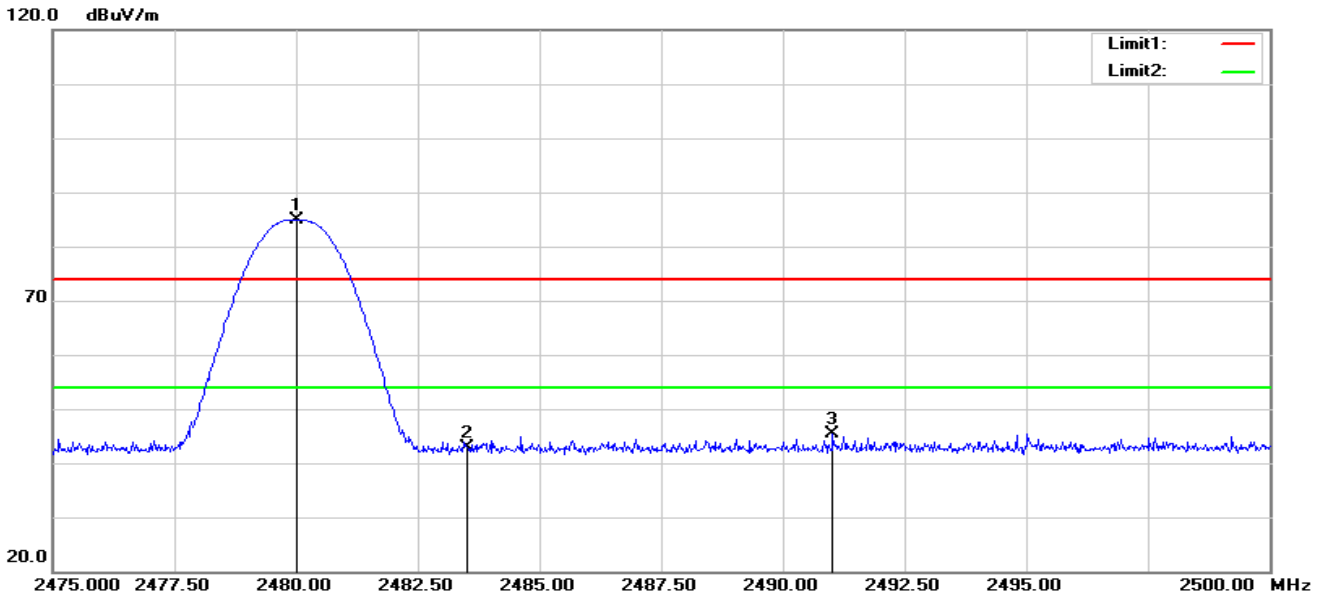

No.	Frequency (MHz)	Reading (dBuV)	Correct Factor(dB/m)	Result (dBuV/m)	Limit (dBuV/m)	Margin (dB)	Remark
2	2483.500	38.38	4.60	42.98	74.00	-31.02	peak
3	2491.025	40.66	4.63	45.29	74.00	-28.71	peak

### Fundamental Frequency

No.	Frequency (MHz)	Reading (dBuV)	Correct Factor(dB/m)	Duty cycle Factor(dB/m)	Result (dBuV/m)	Limit (dBuV/m)	Margin (dB)	Remark
1	2480.000	80.31	4.60	-	84.91	114.00	-29.09	peak
1	2480.000	80.31	4.60	-2.32	82.59	94.00	-11.41	AV



Vertical

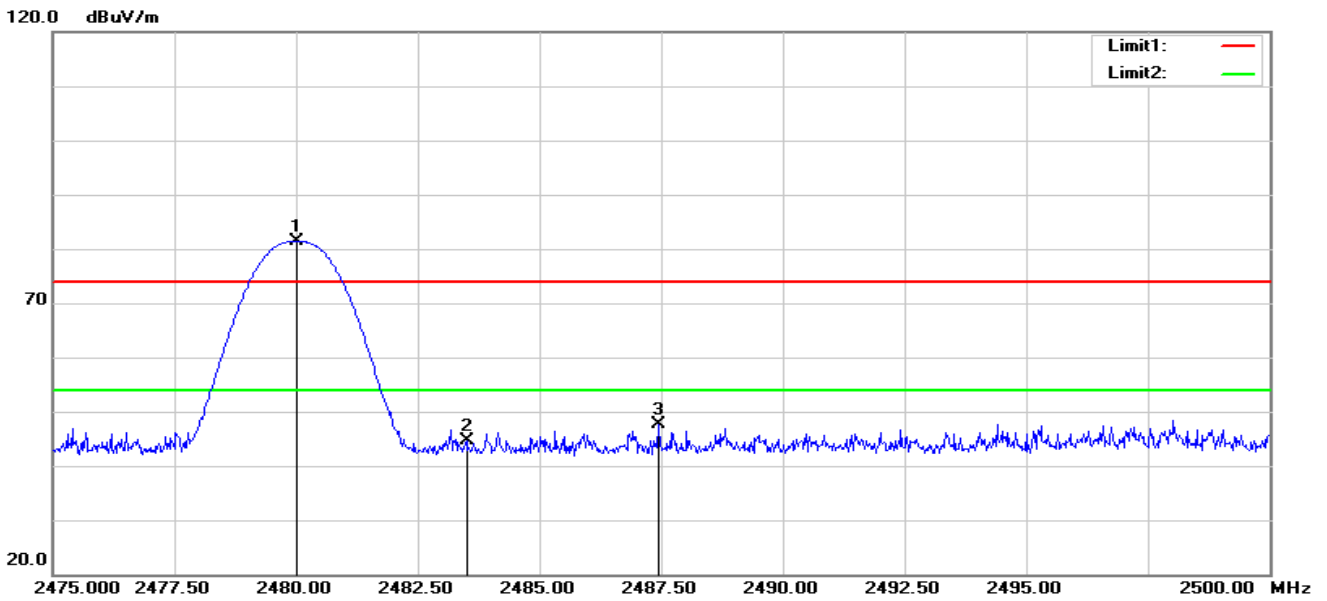

No.	Frequency (MHz)	Reading (dBuV)	Correct Factor(dB/m)	Result (dBuV/m)	Limit (dBuV/m)	Margin (dB)	Remark
2	2483.500	40.11	4.60	44.71	74.00	-29.29	peak
3	2487.450	43.05	4.62	47.67	74.00	-26.33	peak

Fundamental Frequency

No.	Frequency (MHz)	Reading (dBuV)	Correct Factor(dB/m)	Duty cycle Factor(dB/m)	Result (dBuV/m)	Limit (dBuV/m)	Margin (dB)	Remark
1	2480.000	76.67	4.60	-	81.27	114.00	-32.73	peak
1	2480.000	76.67	4.60	-2.32	78.95	94.00	-15.05	AV

Note: AV result=Reading+Correct Factor+Duty cycle Factor

#### 4. BANDWIDTH TEST

##### 4.1 TEST PROCEDURE

- a. The EUT was directly connected to the spectrum analyzer and antenna output port as show in the block diagram below.
- b. Spectrum Setting : RBW= 1% to 5% OBW, VBW $\geq$ RBW, Sweep time = Auto.

##### 4.2 TEST SETUP



##### 4.3 EUT OPERATION CONDITIONS

TX mode.





4.4 TEST RESULTS

Temperature:	25 °C	Relative Humidity:	50%
Test Voltage:	DC 5V		

Test Channel	Frequency(MHz)	20 dB Bandwidth(KHz)	99% Bandwidth(KHz)
CH01	2402	931.1	883.11
CH39	2440	951.5	889.05
CH79	2480	924.8	885.95

Low Channel

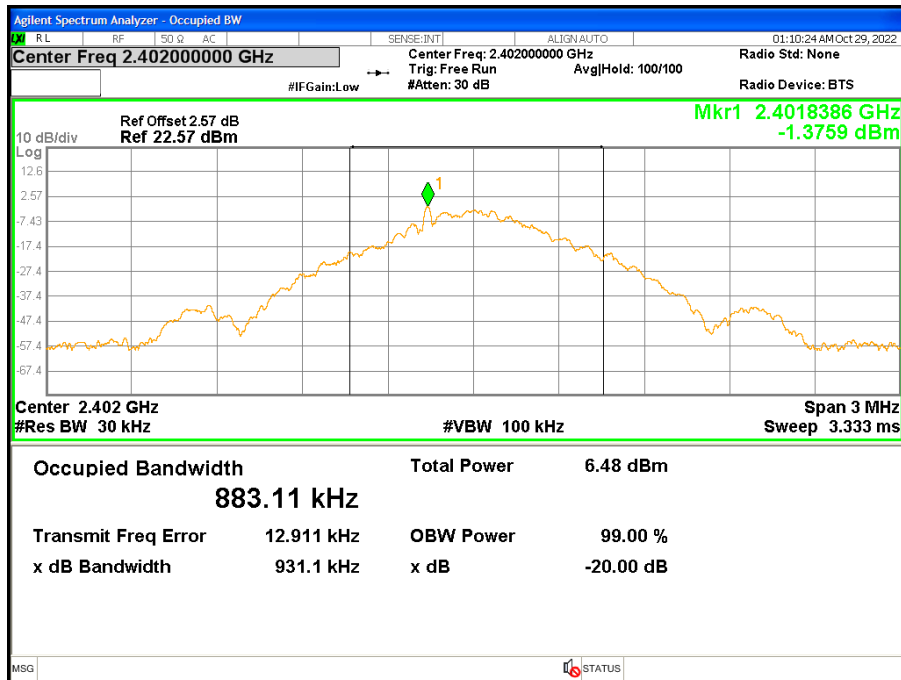





### Mid Channel

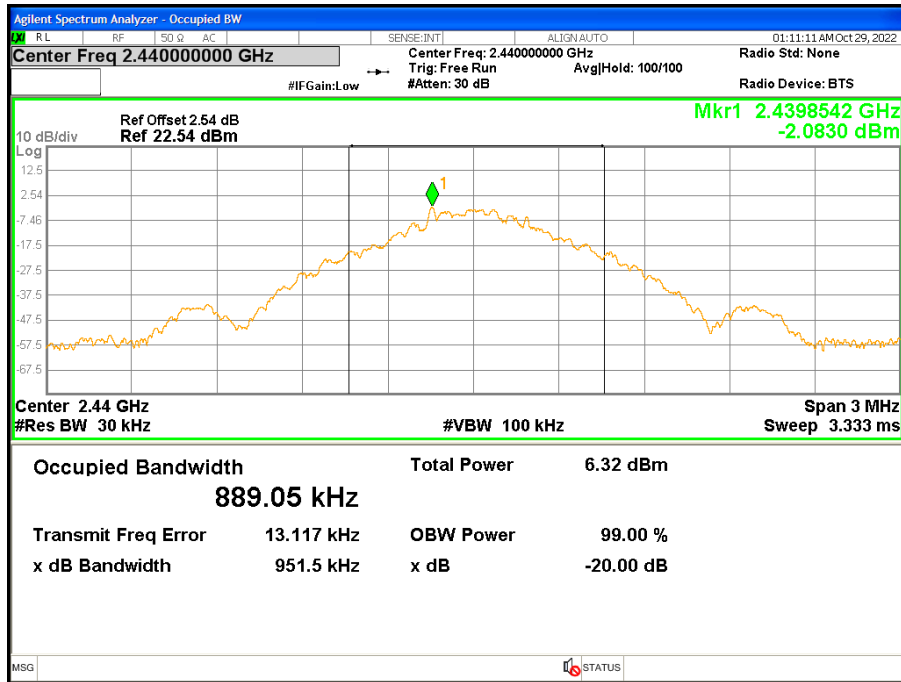

### High Channel

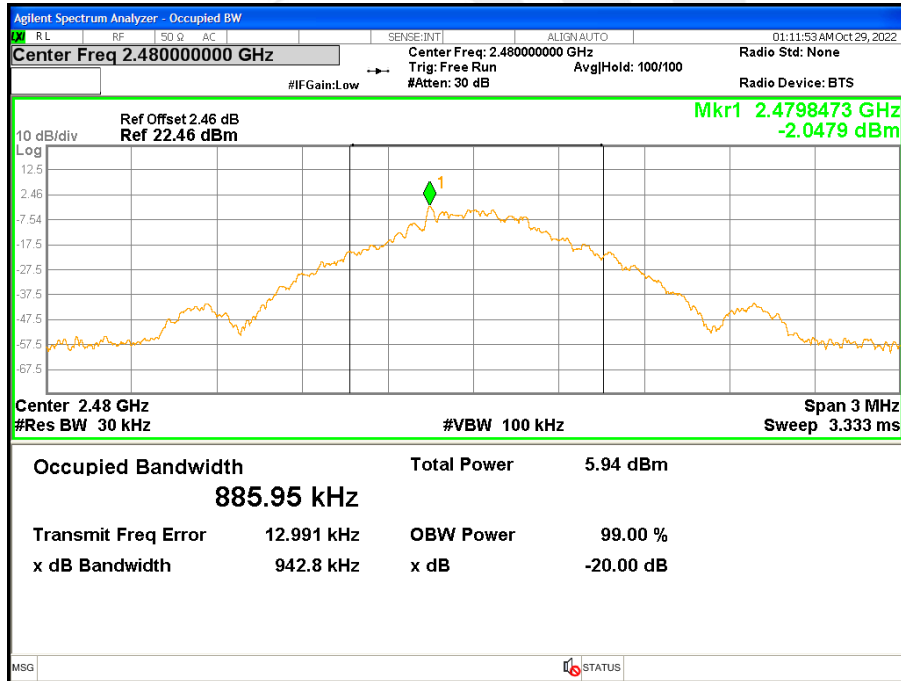



## 5. ANTENNA REQUIREMENT

### 5.1 STANDARD REQUIREMENT

According to the FCC Part 15 Paragraph 15.203, an intentional radiator shall be designed to ensure that no antenna other than that furnished by the responsible party shall be used with the device.

### 5.2 EUT ANTENNA

The EUT antenna is PCB Antenna.It conforms to the standard requirements.





## APPENDIX- PHOTOS OF TEST SETUP

Note: See test photos in setup photo document for the actual connections between Product and support equipment.

\*\*\*\*\*END OF THE REPORT\*\*\*\*\*

