

FCC RADIO TEST REPORT

FCC ID: 2ABYN020

Product : Wireless Handheld Microphone Transmitter

Trade Name : **godox**[®]

Model Name : WH-M1

Family Model : N/A

Report No. : S20081803903001

Prepared for

GODOX PHOTO EQUIPMENT CO.LTD

1st to 4th Floor, Building 2/1st to 4th Floor, Building 4 ,Yaochuan Industrial
Zone, Tangwei Community, Fuhai Street, Baoan District, Shenzhen,
518103 China

Prepared by

Shenzhen NTEK Testing Technology Co., Ltd.

1/F, Building E, Fenda Science Park, Sanwei Community, Xixiang Street
Bao'an District, Shenzhen P.R. China

Tel: 400-800-6106 , 0755-3699-5508

Website: www.ntek.org.cn

TEST RESULT CERTIFICATION

Applicant's name GODOX PHOTO EQUIPMENT CO.LTD
Address 1st to 4th Floor,Building 2/1st to 4th Floor, Building 4 ,Yaochuan Industrial Zone,Tangwei Community,Fuhai Street,Baoan District,Shenzhen, 518103 China

Manufacturer's Name... Godox Photo Equipment Co.,Ltd.
Address 1-4 Floor, Building 2, 1-4 Floor,Building 4, Yaochuan Industrial Zone, Tangwei Community,Fuhai Street, 518103 Bao'an District, Shenzhen, P.R. China

Product description

Product name..... Wireless Handheld Microphone Transmitter

Model and/or type WH-M1
reference

Family Model..... N/A

Standards FCC CFR47 Part 74

Test procedure TIA-603-E: 2016 and KDB 206256 D01 Wireless Microphone Certification v02

This device described above has been tested by NTEK, and the test results show that the equipment under test (EUT) is in compliance with the FCC requirements. And it is applicable only to the tested sample identified in the report.

This report shall not be reproduced except in full, without the written approval of NTEK, this document may be altered or revised by NTEK, personnel only, and shall be noted in the revision of the document.

Date of Test..... :

Date (s) of performance of tests..... : 18 Aug. 2020 ~14 Jan. 2021

Date of Issue..... : 14 Jan. 2021

Test Result..... : Pass

Testing Engineer : [Signature]
(Mary Hu)

Technical Manager : [Signature]
(Jason Chen)

Authorized Signatory : [Signature]
(Alex Li)

Table of Contents

	Page
1 . SUMMARY OF TEST RESULTS	5
1.1 FACILITIES AND ACCREDITATIONS	6
1.1 MEASUREMENT UNCERTAINTY	6
2 . GENERAL INFORMATION	7
2.1 GENERAL DESCRIPTION OF EUT	7
2.2 DESCRIPTION OF TEST MODES	9
2.3 BLOCK DIGRAM SHOWING THE CONFIGURATION OF SYSTEM TESTED	10
2.4 DESCRIPTION OF SUPPORT UNITS(CONDUCTED MODE)	11
2.5 EQUIPMENTS LIST FOR ALL TEST ITEMS	12
3 . EMISSION TEST	13
3.1 RADIATED EMISSION MEASUREMENT	13
3.1.1 APPLICABLE STANDARD	13
3.1.2 CONFORMANCE LIMIT	13
3.1.3 MEASURING INSTRUMENTS	13
3.1.4 TEST CONFIGURATION	13
3.1.5 TEST SETUP	13
3.1.6 TEST PROCEDURE	14
3.1.7 TEST RESULTS (BETWEEN 9KHZ – 30MHZ)	15
3.1.8 TEST RESULTS (BETWEEN 30MHZ– 1GHZ)	16
3.1.9 TEST RESULTS (ABOVE 1000 MHZ)	18
4 . RF OUTPUT POWER	20
4.1 CONDUCTED OUTPUT POWER	20
4.1.1 APPLIED PROCEDURES / LIMIT	20
4.1.2 TEST PROCEDURE	20
4.1.3 TEST SETUP	20
4.1.4 EUT OPERATION CONDITIONS	20
4.1.5 TEST RESULTS	21
5 . MODULATION CHARACTERISTICS	23
5.1 APPLIED PROCEDURES / LIMIT	23
5.2 TEST PROCEDURE	23
5.3 EUT OPERATION CONDITIONS	23

Table of Contents

	Page
5.4 TEST RESULTS	24
6 . OCCUPIED BANDWIDTH OF EMISSION	31
6.1 APPLIED PROCEDURES / LIMIT	31
6.2 TEST PROCEDURE	31
6.3 DEVIATION FROM STANDARD	31
6.4 TEST SETUP	31
6.5 EUT OPERATION CONDITIONS	31
6.6 TEST RESULT	32
7 . SPURIOUS EMISSIONS AT ANTENNA TERMINALS	34
7.1 TEST PROCEDURE	34
7.2 EUT OPERATION CONDITIONS	34
7.3 TEST RESULTS	35
8 . FREQUENCY STABILITY	40
8.1 STANDARD REQUIREMENT	40
8.2 TEST CONFIGURATION	40
8.3 TEST PROCEDURE	40
8.4 TEST RESULT	41
9 . NECESSARY BANDWIDTH (BN) FOR ANALOGUE SYSTEMS	45
9.1 APPLIED PROCEDURES / LIMIT	45
9.2 TEST PROCEDURE	46
9.3 DEVIATION FROM STANDARD	46
9.4 TEST SETUP	46
9.5 EUT OPERATION CONDITIONS	47
9.6 TEST RESULT	47
10 . EUT TEST PHOTO	53

1. SUMMARY OF TEST RESULTS

Test procedures according to the technical standards:

FCC CFR47 Part 74			
Standard Section	Test Item	Judgment	Remark
74.861(e)(1)(ii)	RF Output Power	PASS	
2.1047(a)	Modulation Characteristics	PASS	
2.1049(c)(1)	Occupied Bandwidth	PASS	
2.1053 & 74.861(e)(6)	Radiated Emissions	PASS	
2.1051	Spurious emissions at antenna terminals	PASS	
2.1055(a)(1)	Frequencies Stability	PASS	
74.861(e) (7)	Necessary bandwidth	PASS	

NOTE:

(1) "N/A" denotes test is not applicable in this Test Report

Requirement for Radio Equipment on Certification:

1. RF output Power
For transmitters, the power output shall be measured at the RF output terminals.
2. Modulation Characteristics
For Voice Modulated Communication Equipment, a curve or equivalent data showing the frequency response of the audio modulating circuit over a range of 100 to 5000Hz shall be submitted.
3. Occupied Bandwidth
For radiotelephone transmitter, other than single sideband or indenpent sideband transmitter, where modulated by a 2.5KHz tone at an input level 16 dB greater than that necessary to produce 50 percent modulation.
4. Spurious Emission at Antenna Terminals
The radio frequency voltage or power generated within the equipment and appearing on a spurious Frequency shall be checked at the equipment output terminal when properly loaded with a suitable artificial antenna.
5. Field Strength of Spurious Emission
Measurements shall be made to detect spurious emission that may be radiated directly from the cabinet, control circuits, power leads, or intermediate ciruit elements under normal condition of installation and operation.
6. Frequencies Tolerance
The frequency stability shall be measured with variation of ambient temperature.
The frequency stability shall be measured with variation of primary supply voltage.

1.1 FACILITIES AND ACCREDITATIONS

All measurement facilities used to collect the measurement data are located at
 1/F, Building E, Fenda Science Park, Sanwei Community, Xixiang Street Bao'an District, Shenzhen
 518126 P.R. China

The sites are constructed in conformance with the requirements of ANSI C63.7, TIA-603-E: 2016 and CISPR
 Publication 22.

Site Description

CNAS-Lab. : The Laboratory has been assessed and proved to be in compliance with
 CNAS-CL01:2006 (identical to ISO/IEC 17025:2005)

The Certificate Registration Number is L5516.

IC-Registration : The Certificate Registration Number is 9270A-1.

FCC- Accredited : Test Firm Registration Number: 463705.

Designation Number: CN1184

A2LA-Lab. : The Certificate Registration Number is 4298.01

This laboratory is accredited in accordance with the recognized
 International Standard ISO/IEC 17025:2005 General requirements for
 the competence of testing and calibration laboratories.

This accreditation demonstrates technical competence for a defined
 scope and the operation of a laboratory quality management system
 (refer to joint ISO-ILAC-IAF Communiqué dated 8 January 2009).

Name of Firm : Shenzhen NTEK Testing Technology Co., Ltd.

Site Location : 1/F, Building E, Fenda Science Park, Sanwei Community, Xixiang
 Street, Bao'an District, Shenzhen 518126 P.R. China.

1.1 MEASUREMENT UNCERTAINTY

The reported uncertainty of measurement $y \pm U$, where expanded uncertainty U is based on a
 standard uncertainty multiplied by a coverage factor of $k=2$, providing a level of confidence of
 approximately 95 %.

No.	Item	Uncertainty
1	Conducted Emission Test	$\pm 1.38\text{dB}$
2	RF power,conducted	$\pm 0.16\text{dB}$
3	Spurious emissions,conducted	$\pm 0.21\text{dB}$
4	All emissions,radiated(<1G)	$\pm 4.68\text{dB}$
5	All emissions,radiated(>1G)	$\pm 4.89\text{dB}$
6	Temperature	$\pm 0.5^\circ\text{C}$
7	Humidity	$\pm 2\%$

2. GENERAL INFORMATION

2.1 GENERAL DESCRIPTION OF EUT

Equipment	Wireless Handheld Microphone Transmitter	
Trade Name	godox®	
Model Name	WH-M1	
Family Model	N/A	
Model Difference	N/A	
Product Description	The EUT is a Wireless Handheld Microphone Transmitter	
	Operation Frequency:	514.56 MHz~595.66MHz
	Modulation Type:	FM
	Number Of Channel	96CH(Please see Note 2.)
	Antenna Designation:	Please see Note 3.
	Antenna Gain (dBi)	0dBi
Channel List	Please refer to the Note 2.	
Ratings	DC 3V powered by Battery	
Adapter	N/A	
Battery	N/A	
Connecting I/O Port(s)	Please refer to the User's Manual	

Note:

1. For a more detailed features description, please refer to the manufacturer's specifications or the User's Manual.

2.

The transmitting frequency is divided into group A and group B:

Group A		Group B	
Channel	Frequency (MHz)	Channel	Frequency (MHz)
1	514.56	1	534.65
2	514.97	2	535.06
3	515.38	3	535.47
.....
.....
.....
.....
.....
.....
.....
46	533.01	46	553.10
47	533.42	47	553.51
48	533.83	48	595.66

Note: $f_c = 514.56\text{MHz} + (k-1) \times 0.41\text{MHz}$ or $534.65\text{MHz} + (k-1) \times 0.41\text{MHz}$ $k=1$ to 48

3.

Table for Filed Antenna

Ant	Brand	Model Name	Antenna Type	Connector	Gain (dBi)	NOTE
A	N/A	N/A	PCB antenna	N/A	0	Antenna

2.2 DESCRIPTION OF TEST MODES

To investigate the maximum EMI emission characteristics generates from EUT, the test system was pre-scanning tested base on the consideration of following EUT operation mode or test configuration mode which possible have effect on EMI emission level. Each of these EUT operation mode(s) or test configuration mode(s) mentioned above was evaluated respectively.

Pretest Mode	Description
Mode 1	TX(CH01/ CH25/ CH48)

For Radiated Emission	
Final Test Mode	Description
Mode 1	TX(CH01/ CH25/ CH48)

For Conduction Emission	
Final Test Mode	Description
Mode 1	TX(CH01/ CH25/ CH48)

2.3 BLOCK DIGRAM SHOWING THE CONFIGURATION OF SYSTEM TESTED

For Radiated Test Cases

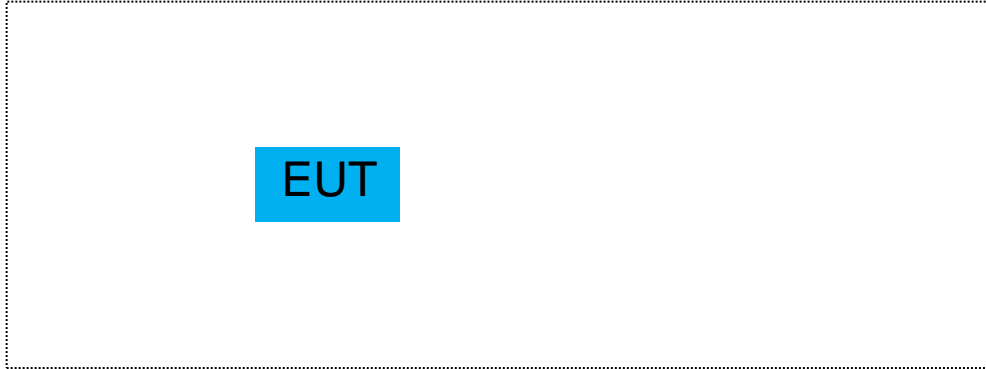

For Conducted Test Cases

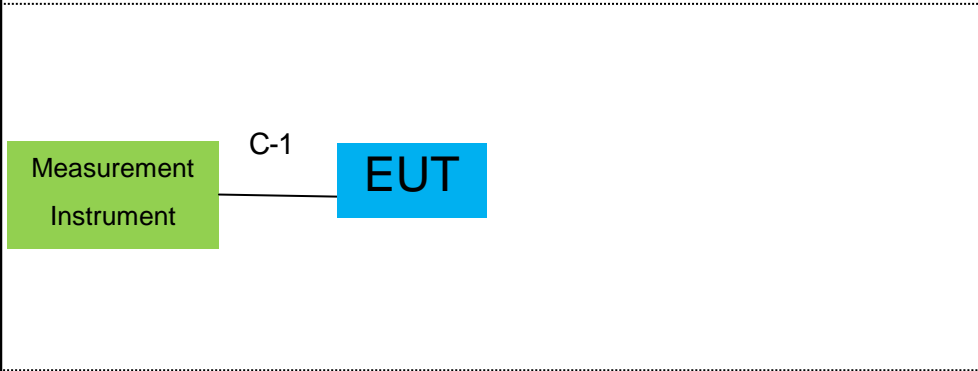

Note: Use new battery during the test.

2.4 DESCRIPTION OF SUPPORT UNITS(CONDUCTED MODE)

The EUT has been tested as an independent unit together with other necessary accessories or support units. The following support units or accessories were used to form a representative test configuration during the tests.

Item	Equipment	Brand	Model/Type No.	Series No.	Note
E-1	Wireless Handheld Microphone Transmitter		WH-M1	N/A	EUT

Item	Cable Type	Shielded Type	Ferrite Core	Length
C-1	RF Cable	YES	NO	0.1m

Note:

- (1) The support equipment was authorized by Declaration of Confirmation.
- (2) For detachable type I/O cable should be specified the length in cm in 『Length』 column.

2.5 EQUIPMENTS LIST FOR ALL TEST ITEMS

Radiation Test equipment

Item	Kind of Equipment	Manufacturer	Type No.	Serial No.	Last calibration	Calibrated until	Calibration period
1	Spectrum Analyzer	Agilent	E4407B	MY45108040	2020.05.11	2021.05.10	1 year
2	Test Receiver	R&S	ESPI	101318	2020.05.11	2021.05.10	1 year
3	Bilog Antenna (30MHz-1GHz)	TESEQ	CBL6111D	31216	2020.04.11	2021.04.10	1 year
4	50Ω Coaxial Switch	Anritsu	MP59B	6200264416	2020.05.11	2023.05.10	3 year
5	Spectrum Analyzer	ADVANTES T	R3132	150900201	2020.05.11	2021.05.10	1 year
6	Horn Antenna (1-18GHz)	EM	EM-AH-10180	2011071402	2020.04.15	2021.04.14	1 year
7	Horn Ant (1-18GHz)	Schwarzbeck	BBHA 9170	9170-181	2019.12.10 2020.12.09	2020.12.09 2021.12.08	1 year
8	Amplifier	EM	EM-30180	060538	2020.05.11	2021.05.10	1 year
9	Loop Antenna (9KHz-30MHz)	ARA	PLA-1030/B	1029	2019.12.11	2020.12.10	1 year
10	Power Meter	R&S	NRVS	100696	2020.05.11	2021.05.10	1 year
11	Power Sensor	R&S	URV5-Z4	0395.1619.05	2020.05.11	2021.05.10	1 year
12	Modulation Analyzer	HP	8920B	-	2020.05.11	2021.05.10	1 year
13	MXA Signal Analyzer	Agilent	N9020A	MY49100060	2020.05.13	2021.05.12	1 year
14	Substitution Antenna (30MHz-1GHz)	Schwarzbeck	VULB 9160	9160-3309	2020.05.13	2021.05.12	1 year

Conduction Test equipment

Item	Kind of Equipment	Manufacturer	Type No.	Serial No.	Last calibration	Calibrated until	Calibration period
1	Test Receiver	R&S	ESCI	101160	2020.05.11	2021.05.10	1 year
2	LISN	R&S	ENV216	101313	2020.04.15	2021.04.14	1 year
3	LISN	EMCO	3816/2	00042990	2020.05.13	2021.05.12	1 year
4	50Ω Coaxial Switch	Anritsu	MP59B	6200264417	2020.05.11	2023.05.10	3 year
5	Passive Voltage Probe	R&S	ESH2-Z3	100196	2020.05.11	2021.05.10	1 year
6	Absorbing clamp	R&S	MOS-21	100423	2020.05.11	2021.05.10	1 year

3. EMISSION TEST

3.1 RADIATED EMISSION MEASUREMENT

3.1.1 Applicable standard

According to FCC §74.861 (e) (6) (iii) and ANSI/TIA-603-E-2016 Section 2.2.12

3.1.2 Conformance limit

On any frequency removed from the operating frequency by more than 250 percent of the authorized bandwidth: at least $43 + 10\log$ (mean output power in watts) dB.

3.1.3 Measuring instruments

The Measuring equipment is listed in the section 6.3 of this test report.

3.1.4 Test configuration

According to the ANSI/TIA-603-E-2016 test method, The Receiver or Spectrum was scanned from 9 KHz to the 10th harmonic of the highest frequency generated within the equipment, which is the transmitted carrier that can be as high as 1910 MHz The resolution bandwidth is set as outlined in Part FCC §74.861 (e) (6) (iii).

3.1.5 Test setup

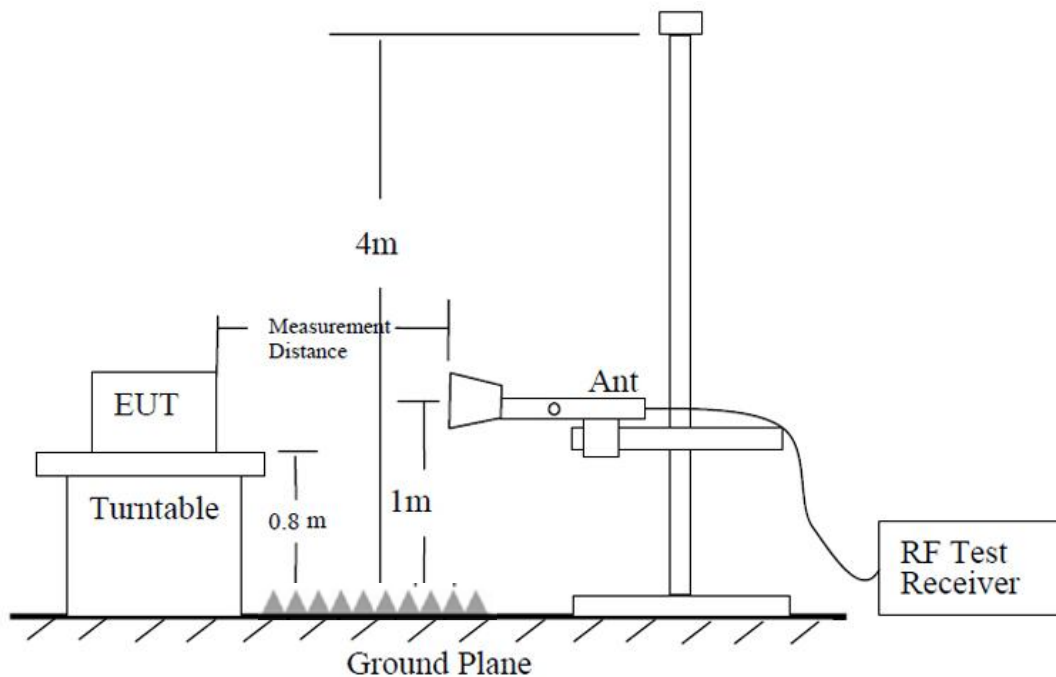

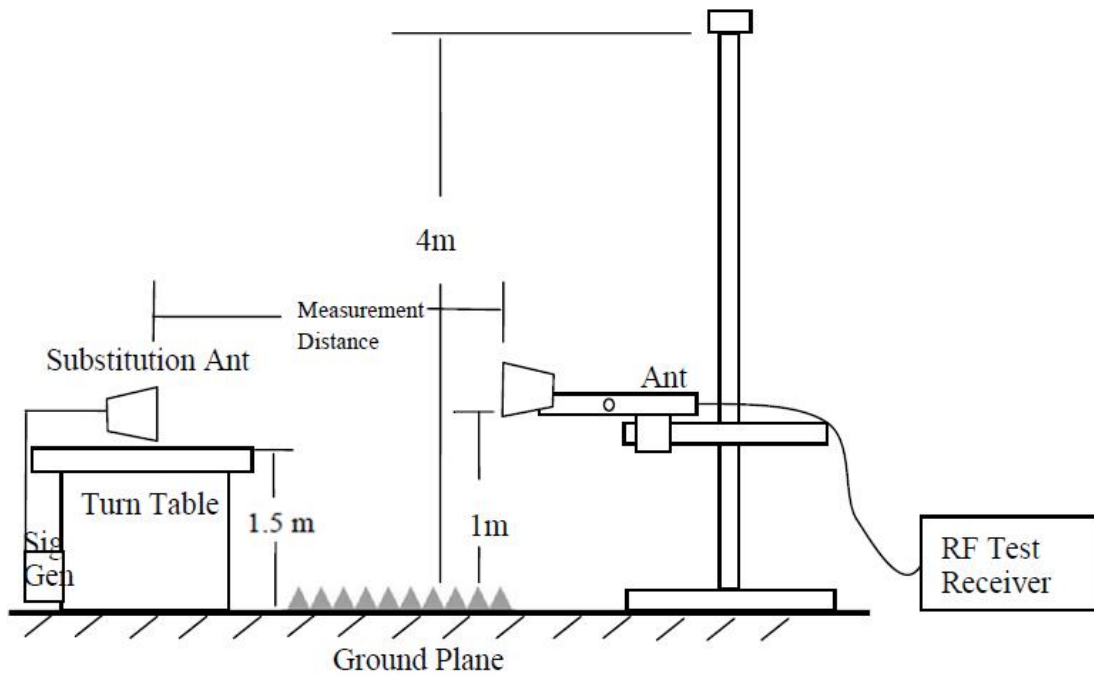

3.1.6 Test procedure

1. EUT was placed on a 0.8 meter (For frequency above 1G, EUT should be placed on 1.5m) high non-conductive stand at a 3 meter test distance from the receive antenna. A receiving antenna was placed on the antenna mast 3 meters from the EUT for emission measurements. The height of receiving antenna is 1.50 meter. Detected emissions were maximized at each frequency by rotating the EUT through 360° and adjusting the receiving antenna polarization. The radiated emission measurements of all transmit frequencies in three channels (High, Middle, Low) were measured with peak detector.
2. A log-periodic antenna or double-ridged waveguide horn antenna shall be substituted in place of the EUT. The log-periodic antenna will be driven by a signal generator and the level will be adjusted till the same power value on the spectrum analyzer or receiver. The level of the spurious emissions can be calculated through the level of the signal generator, cable loss, the gain of the substitution antenna and the reading of the spectrum analyzer or receiver.
3. The EUT is then put into continuously transmitting mode at its maximum power level during the test. Set Test Receiver or Spectrum RBW=1MHz, VBW=3MHz, And the maximum value of the receiver should be recorded as (P_r).
4. The EUT shall be replaced by a substitution antenna. In the chamber, an substitution antenna for the frequency band of interest is placed at the reference point of the chamber. An RF Signal source for the frequency band of interest is connected to the substitution antenna with a cable that has been constructed to not interfere with the radiation pattern of the antenna. A power (SG Level) is applied to the input of the substitution antenna, and adjust the level of the signal generator output until the value of the receiver reach the previously recorded (P_r). The power of signal source (SG Level) is recorded. The test should be performed by rotating the test item and adjusting the receiving antenna polarization.
5. A amplifier should be connected to the Signal Source output port. And the cable should be connect between the Amplifier and the Substitution Antenna. The cable loss (Cable Loss), the Substitution Antenna Gain should be recorded after test.

The measurement results are obtained as described below:

Power(EIRP)= SG Level- Cable Loss+ Antenna Gain

6. This value is EIRP since the measurement is calibrated using an antenna of known gain (2.15 dBi) and known input power.
7. ERP can be calculated from EIRP by subtracting the gain of the dipole, ERP = EIRP -2.15dBi.

3.1.7 Test results (between 9KHz – 30MHz)

EUT:	Wireless Handheld Microphone Transmitter	Model Name. :	WH-M1
Temperature:	20 °C	Relative Humidity:	48%
Pressure:	1010 hPa	Test Voltage :	N/A
Test Mode :	N/A	Polarization :	--

Freq.	Reading	Limit	Margin	State
(MHz)	(dBuV/m)	(dBuV/m)	(dB)	P/F
--	--	--	--	N/A
--	--	--	--	N/A

NOTE:

1. Emission level in dBuV/m=20 log (uV/m)
2. Measurement was performed at an antenna to the closed point of EUT distance of meters.
3. For Frequency 9kHz~30MHz:
 Distance extrapolation factor =40log(Specific distance/ test distance)(dB);
 Limit line=Specific limits(dBuV) + distance extrapolation factor.
 For Frequency above 30MHz:
 Distance extrapolation factor =20log(Specific distance/ test distance)(dB);

3.1.8 Test results (between 30MHz– 1GHz)

EUT :	Wireless Handheld Microphone Transmitter	Model Name :	WH-M1
Temperature :	20 °C	Relative Humidity :	48%
Pressure:	1010 hPa	Test Voltage :	DC 3V
Test Mode :	TX-CH 25 for group A		

Polar (H/V)	Freque ncy	Power	Cable loss	Antenna Factor	Absolute Level	Limits	Margin	Remark
	(MHz)	(dBm)	(dB)	(dB)	(dBm)	(dBm)	(dB)	
V	95.871	-59.78	0.24	28.67	-30.87	-13	-17.87	peak
V	172.041	-55.59	0.34	22.42	-32.83	-13	-19.83	peak
V	234.827	-55.10	0.37	24.47	-30.26	-13	-17.26	peak
V	299.128	-56.43	0.42	22.52	-33.49	-13	-20.49	peak
V	447.006	-66.67	0.46	29.29	-36.92	-13	-23.92	peak
V	760.009	-71.32	0.48	34.58	-36.26	-13	-23.26	peak
H	107.332	-58.52	0.26	26.55	-31.71	-13	-18.71	peak
H	169.475	-57.89	0.32	18.8	-38.77	-13	-25.77	peak
H	258.217	-60.22	0.35	24.5	-35.37	-13	-22.37	peak
H	312.134	-55.82	0.44	23.15	-32.23	-13	-19.23	peak
H	430.874	-63.67	0.45	27.86	-35.36	-13	-22.36	peak
H	581.186	-71.29	0.46	30.79	-40.04	-13	-27.04	peak

Remark:

Absolute Level= Power - Cable Loss+ Antenna Factor

Margin= Absolute Level - Limit

Note: TX-CH 25 is the worst case in the radiated spurious emission test with a frequency of 30MHz~1GHz.

EUT :	Wireless Handheld Microphone Transmitter	Model Name :	WH-M1
Temperature :	20 °C	Relative Humidity :	48%
Pressure:	1010 hPa	Test Voltage :	DC 3V
Test Mode :	TX-CH 25 for group B		

Polar (H/V)	Frequency	Power	Cable loss	Antenna Factor	Absolute Level	Limits	Margin	Remark
	(MHz)	(dBm)	(dB)	(dB)	(dBm)	(dBm)	(dB)	
V	96.3683	-59.37	0.24	28.67	-30.46	-13	-17.46	peak
V	172.612	-55.31	0.34	22.42	-32.55	-13	-19.55	peak
V	235.671	-54.46	0.37	24.47	-29.62	-13	-16.62	peak
V	299.366	-55.92	0.42	22.52	-32.98	-13	-19.98	peak
V	447.182	-65.98	0.46	29.29	-36.23	-13	-23.23	peak
V	760.218	-71.14	0.48	34.58	-36.08	-13	-23.08	peak
H	108.093	-58.02	0.26	26.55	-31.21	-13	-18.21	peak
H	169.651	-57.18	0.32	18.8	-38.06	-13	-25.06	peak
H	258.345	-59.82	0.35	24.5	-34.97	-13	-21.97	peak
H	312.142	-54.84	0.44	23.15	-31.25	-13	-18.25	peak
H	431.196	-63.48	0.45	27.86	-35.17	-13	-22.17	peak
H	581.76	-70.92	0.46	30.79	-39.67	-13	-26.67	peak

Remark:

Absolute Level= Power - Cable Loss+ Antenna Factor

Margin= Absolute Level - Limit

Note: TX-CH 25 is the worst case in the radiated spurious emission test with a frequency of 30MHz~1GHz.

3.1.9 Test results (above 1000 MHz)

EUT :	Wireless Handheld Microphone Transmitter	Model Name :	WH-M1
Temperature :	20 °C	Relative Humidity :	48%
Pressure:	1010 hPa	Test Voltage :	DC 3V
Test Mode :	TX for group A		

Polar (H/V)	Frequency (MHz)	Power	Cable loss	Antenna Factor	Absolute Level	Limits	Margin	Detector Type
		(dBm)	(dB)	(dB)	(dBm)	(dBm)	(dB)	
CH 01								
V	1029.30	-10.02	1.24	-14.29	-23.07	-13	-10.07	peak
V	1543.95	-12.33	1.45	-12.58	-23.46	-13	-10.46	peak
H	1029.30	-15.44	1.24	-14.29	-28.49	-13	-15.49	peak
H	1543.95	-16.02	1.45	-12.58	-27.15	-13	-14.15	peak
CH 25								
V	1048.80	-12.12	1.25	-14.66	-25.53	-13	-12.53	peak
V	1573.20	-11.36	1.46	-13.65	-23.55	-13	-10.55	peak
H	1048.80	-15.45	1.25	-14.66	-28.86	-13	-15.86	peak
H	1573.20	-13.65	1.46	-13.65	-25.84	-13	-12.84	peak
CH 48								
V	1067.66	-17.22	1.27	-14.93	-30.88	-13	-17.88	peak
V	1601.49	-15.32	1.49	-11.2	-25.03	-13	-12.03	peak
H	1179.00	-12.24	1.27	-14.93	-25.9	-13	-12.9	peak
H	1768.50	-11.89	1.49	-11.2	-21.6	-13	-8.6	peak

Remark:

Absolute Level= Power - Cable Loss+ Antenna Factor

Margin= Absolute Level - Limit

EUT :	Wireless Handheld Microphone Transmitter	Model Name :	WH-M1
Temperature :	20 °C	Relative Humidity :	48%
Pressure:	1010 hPa	Test Voltage :	DC 3V
Test Mode :	TX for group B		

Polar (H/V)	Frequency (MHz)	Power	Cable loss	Antenna Factor	Absolute Level	Limits	Margin	Detector Type
		(dBm)	(dB)	(dB)	(dBm)	(dBm)	(dB)	
CH 01								
V	1110.00	-9.99	1.24	-14.29	-23.04	-13	-10.04	peak
V	1665.00	-11.39	1.45	-12.58	-22.52	-13	-9.52	peak
H	1110.00	-14.52	1.24	-14.29	-27.57	-13	-14.57	peak
H	1665.00	-15.77	1.45	-12.58	-26.9	-13	-13.9	peak
CH 25								
V	1172.46	-11.63	1.25	-14.66	-25.04	-13	-12.04	peak
V	1758.69	-11.27	1.46	-13.65	-23.46	-13	-10.46	peak
H	1172.46	-15.03	1.25	-14.66	-28.44	-13	-15.44	peak
H	1758.69	-13.48	1.46	-13.65	-25.67	-13	-12.67	peak
CH 48								
V	1191.32	-16.25	1.27	-14.93	-29.91	-13	-16.91	peak
V	1786.98	-14.5	1.49	-11.2	-24.21	-13	-11.21	peak
H	1191.32	-11.87	1.27	-14.93	-25.53	-13	-12.53	peak
H	1786.98	-11.24	1.49	-11.2	-20.95	-13	-7.95	peak

Remark:

Absolute Level= Power - Cable Loss+ Antenna Factor

Margin= Absolute Level - Limit

4. RF OUTPUT POWER

4.1 Conducted Output Power

4.1.1 APPLIED PROCEDURES / LIMIT

Test requirement: FCC CFR47 Part 74 Section 74.861(e)(1)(ii)

Limit: According to Part 74.861(e)(1)(ii), the output power shall not exceed 250mW (23.98 dBm).

4.1.2 TEST PROCEDURE

The maximum peak output power was measured with a spectrum analyzer connected to the antenna terminal (conducted measurement) while EUT was operating in normal situation.

Detector: Peak (worst case)

Sweep time: Auto /

Resolution bandwidth: > emission bandwidth

Video bandwidth: > resolution bandwidth

Span: > 2 times emissions bandwidth

Trace mode: Max. hold

EUT configuration: Peak:
Unmodulated carrier

4.1.3 TEST SETUP



4.1.4 EUT OPERATION CONDITIONS

The EUT tested system was configured as the statements of 2.4 Unless otherwise a special operating condition is specified in the follows during the testing.

4.1.5 TEST RESULTS

EUT :	Wireless Handheld Microphone Transmitter	Model Name :	WH-M1
Temperature :	25 °C	Relative Humidity :	56%
Pressure :	1015 hPa	Test Voltage :	DC 3V
Test Mode :	TX		

Group A

Test Channel	Frequency	Conducted Output Power (PK)	Cable loss	Maximum Conducted Output Power(PK)	LIMIT
	(MHz)	(dBm)	(dBm)	(dBm)	dBm
CH 01	514.56	-5.855	1	-4.855	23.98
CH 25	524.4	-4.576	1	-3.576	23.98
CH 48	533.83	-4.519	1	-3.519	23.98

Group B

Test Channel	Frequency	Conducted Output Power (PK)	Cable loss	Maximum Conducted Output Power(PK)	LIMIT
	(MHz)	(dBm)	(dBm)	(dBm)	dBm
CH 01	534.65	-4.591	1	-3.591	23.98
CH 25	544.49	-5.436	1	-4.436	23.98
CH 48	595.66	-6.623	1	-5.623	23.98

Test plot for Group A

TX CH01

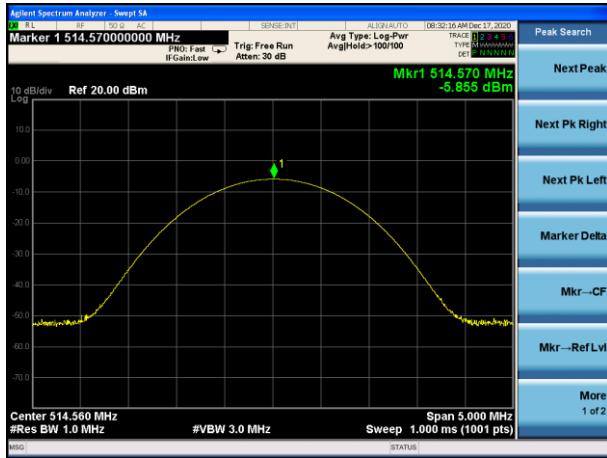

Test plot for Group B

TX CH01

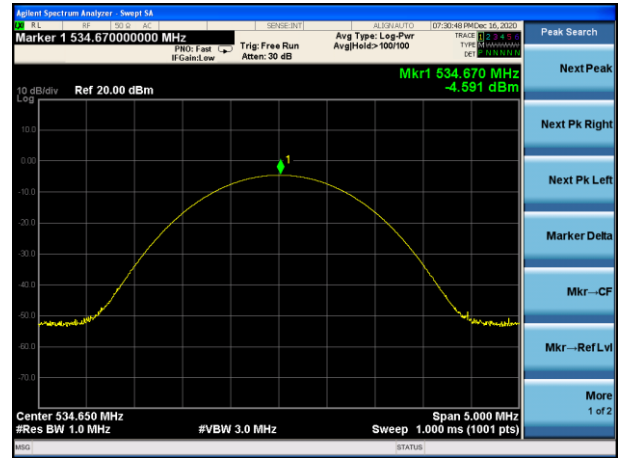

TX CH25

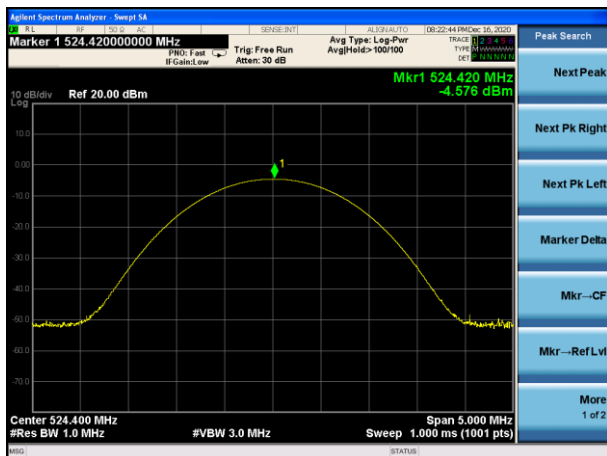

TX CH25

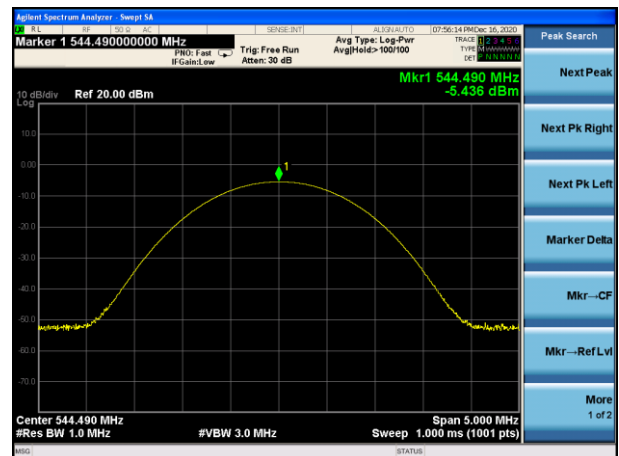

TX CH48

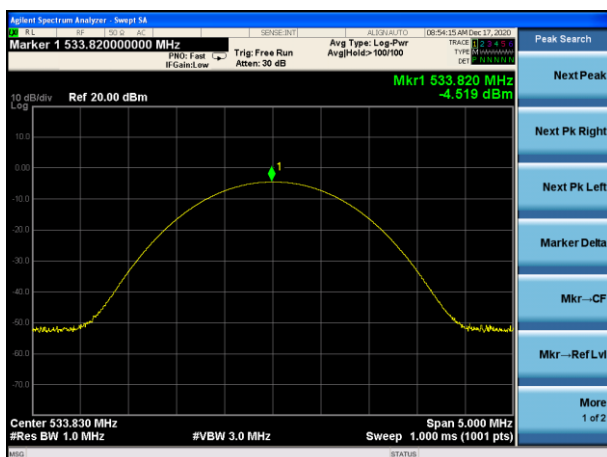

TX CH48

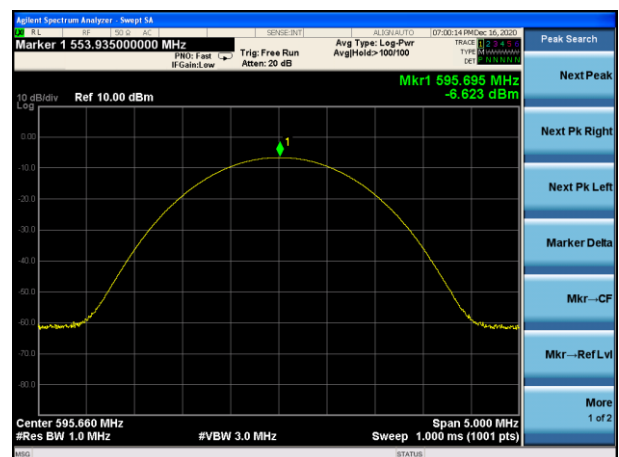

5. MODULATION CHARACTERISTICS

5.1 APPLIED PROCEDURES / LIMIT

Test requirement: FCC CFR47 Part 2 Section 2.1047(a)

Test method: According to ANSI/TIA-603-E 2016 section 2.2.3,

Requirement: According to Part 2.1047(a), for Voice Modulated Communication Equipment, the frequency response of the audio modulating circuit over a range of 100Hz to 5000Hz shall be measured.

5.2 TEST PROCEDURE

(a) Test Configuration

(b) Audio Frequency Response:

- 1) Apply a 1000 Hz tone and adjust the audio frequency generator to produce 20% of the rated system deviation.
- 2) Set the test receiver to measure rms deviation and record the deviation reading as DEVREF .
- 3) Set the audio frequency generator to the desired test frequency between 100 Hz and 5000 Hz.
- 4) Record the test receiver deviation reading as DEVFREQ .
- 5) Calculate the audio frequency response at the present frequency as:
 $\text{audio frequency response} = 20\lg(\text{DEVFREQ} / \text{DEVREF})$
- 6) Repeat steps 4) through 5) for all the desired test frequencies.

(c) Modulation Limiting:

- 1) Apply a 1000 Hz modulating signal to the transmitter from the audio frequency generator, and adjust the level to obtain 60% of full rated system deviation.
- 2) Measure both the instantaneous and steady-state deviation at and after the time of increasing the audio input level.
- 3) With the level from the audio frequency generator held constant at the level obtained in step e), slowly vary the audio frequency from 300 Hz to 3000Hz and observe the steady-state deviation. Record the maximum deviation.
- 4) Set the test receiver to measure peak negative deviation and repeat steps 1) through 3).
- 5) The values recorded in steps 3) and 4) are the modulation limiting.

TEST SETUP

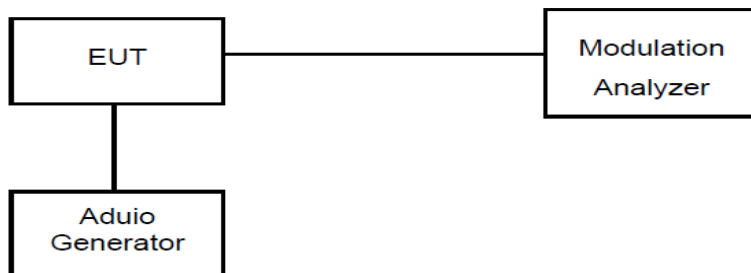

5.3 EUT OPERATION CONDITIONS

The EUT tested system was configured as the statements of 2.4 Unless otherwise a special operating condition is specified in the follows during the testing.

5.4 TEST RESULTS

EUT :	Wireless Handheld Microphone Transmitter	Model Name :	WH-M1
Temperature :	25 °C	Relative Humidity :	56%
Pressure :	1012 hPa	Test Voltage :	DC 3V
Test Mode :	TX		

TX 514.26MHz

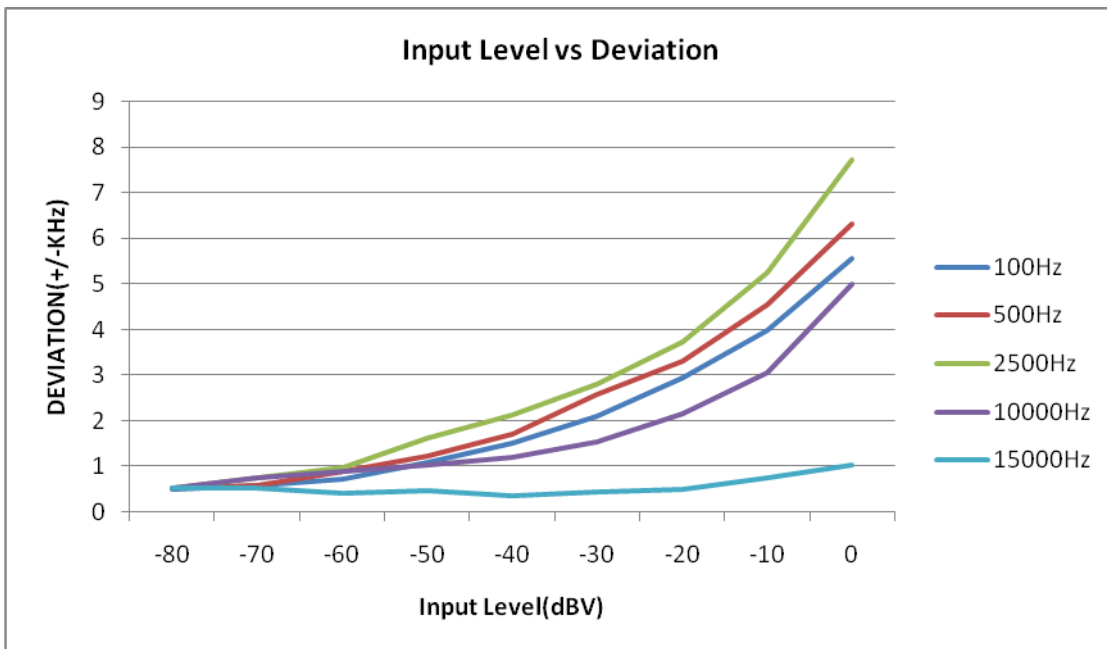
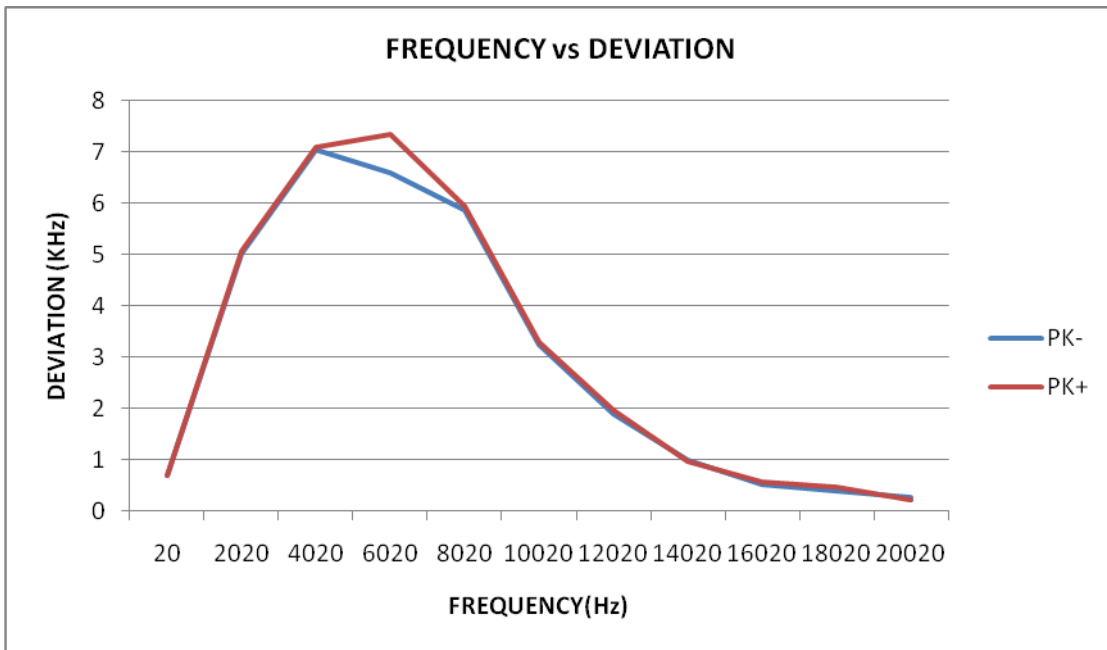

TX 524.4MHz

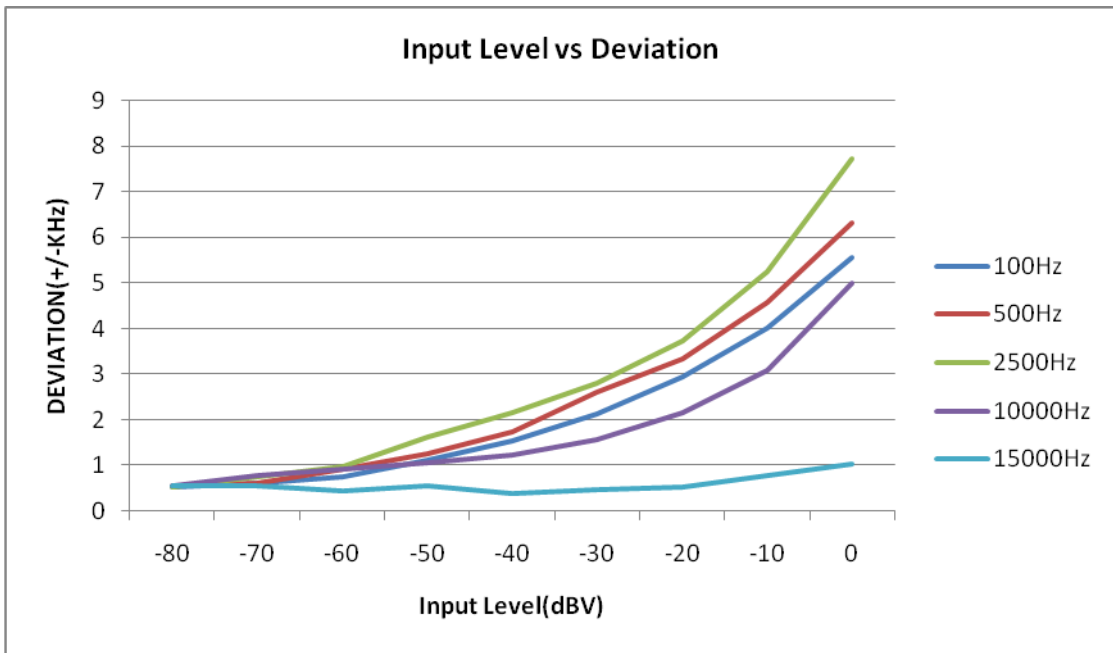
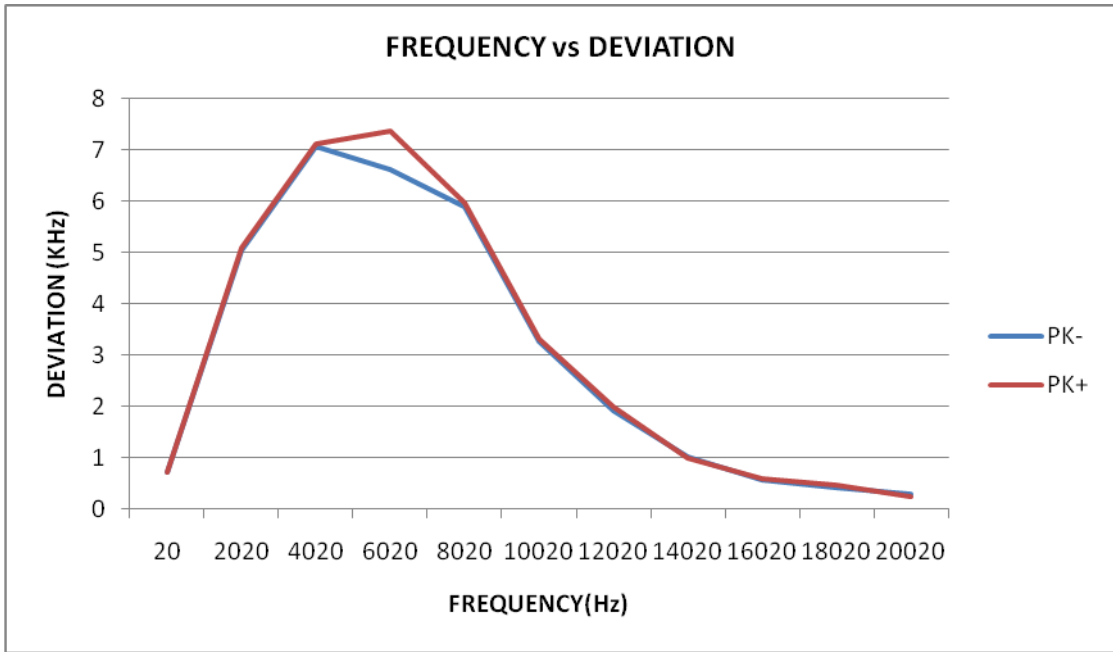

TX 533.83MHz

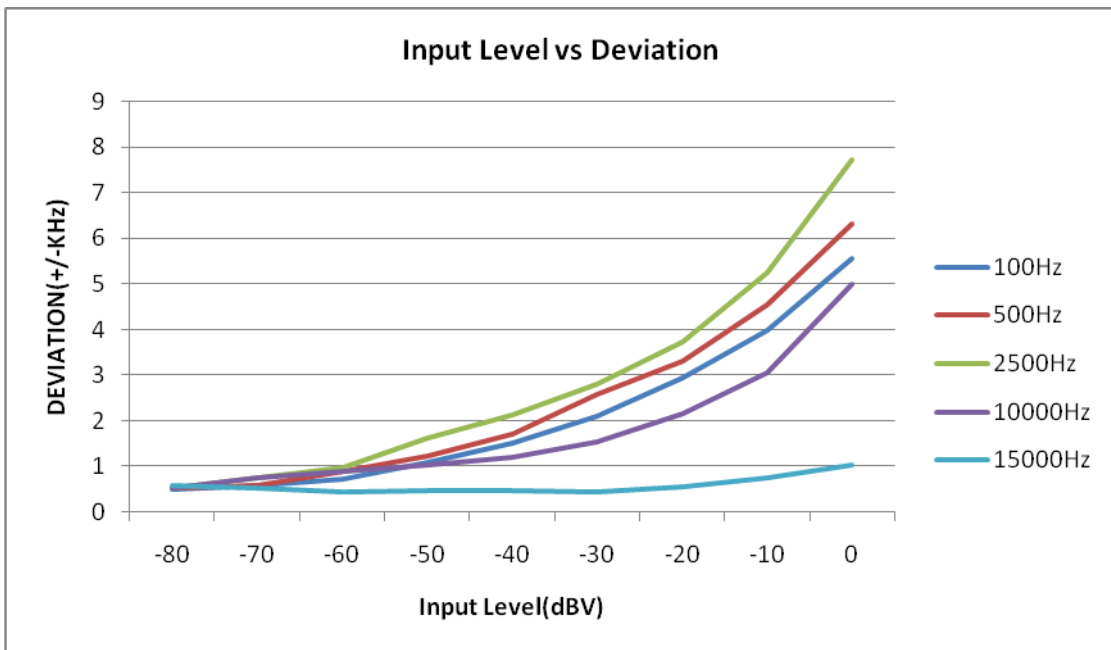
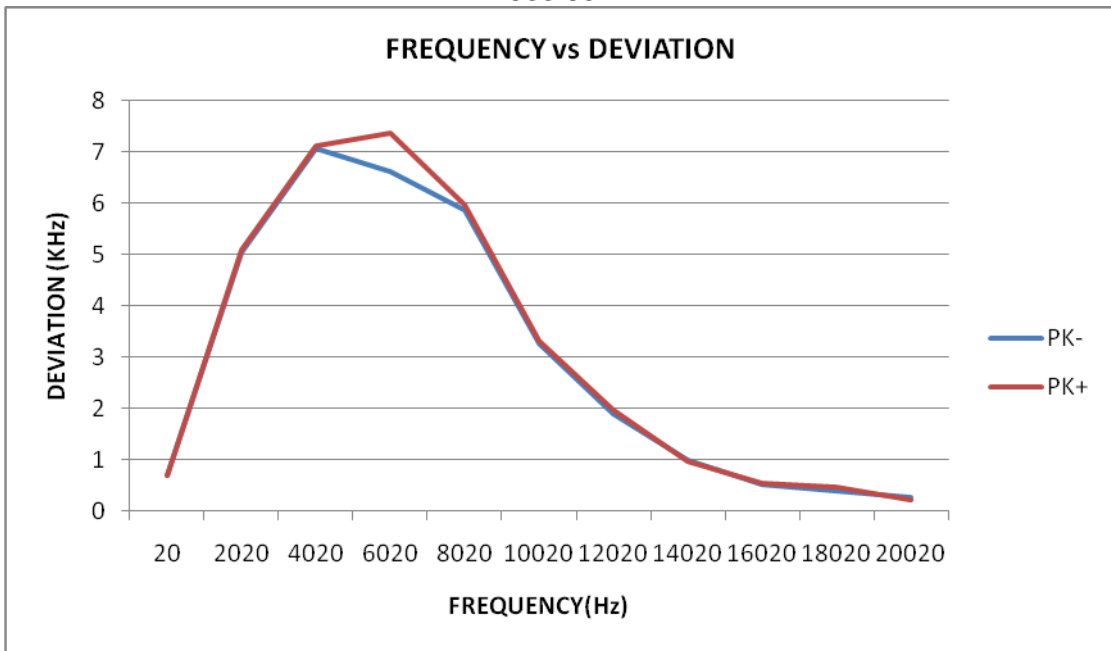

TX 534.65MHz

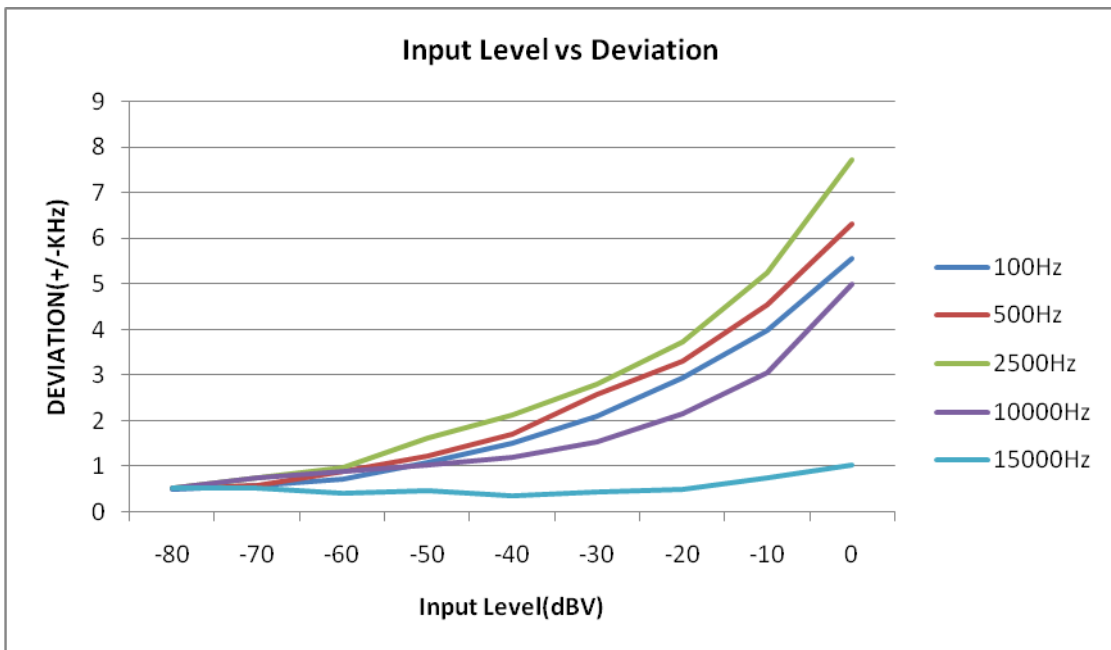
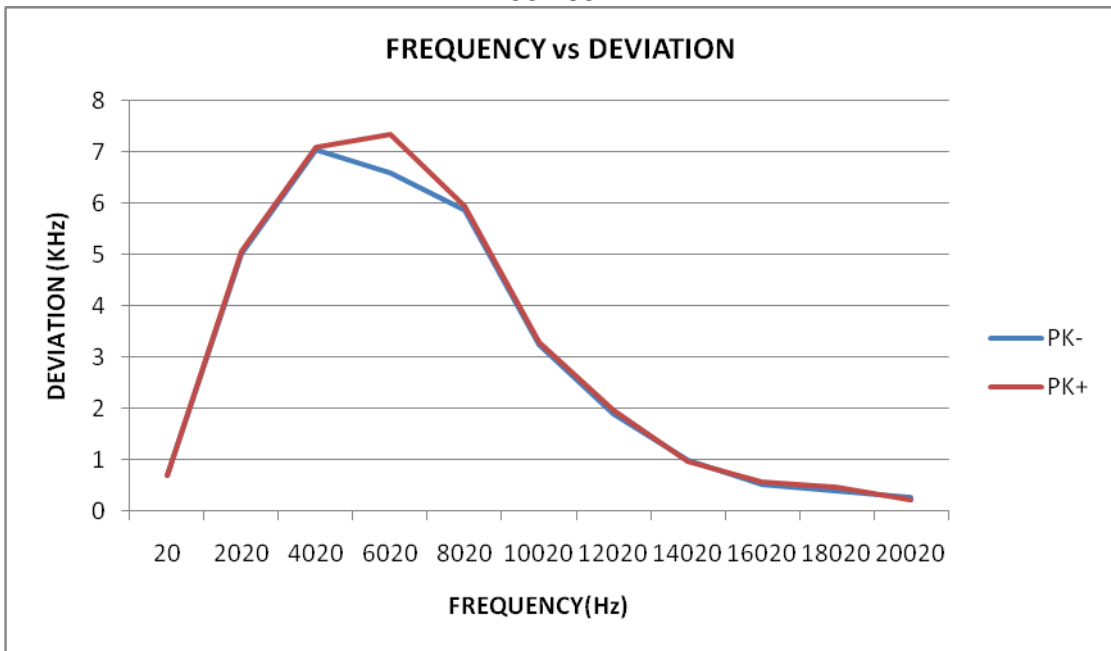

TX 586.23MHz

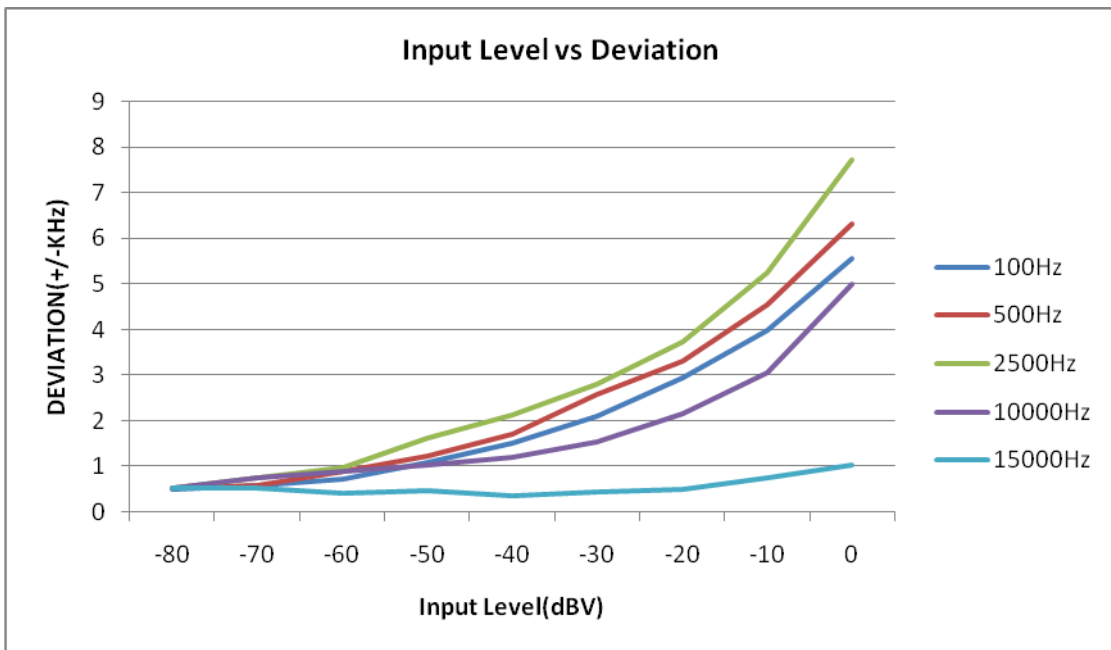
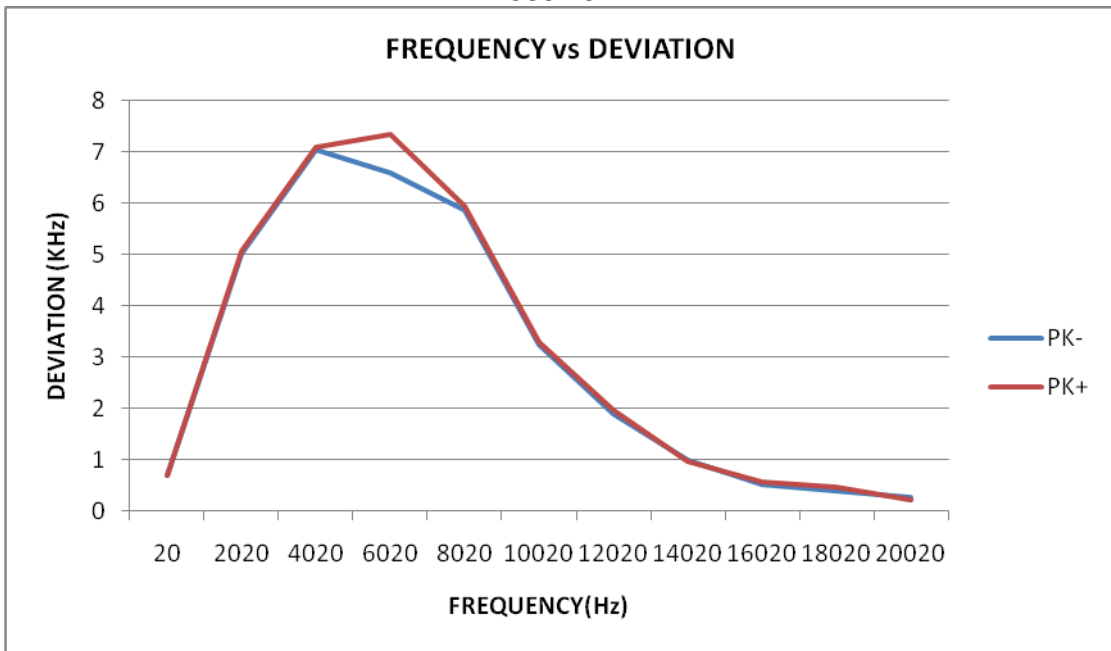

TX 544.49MHz

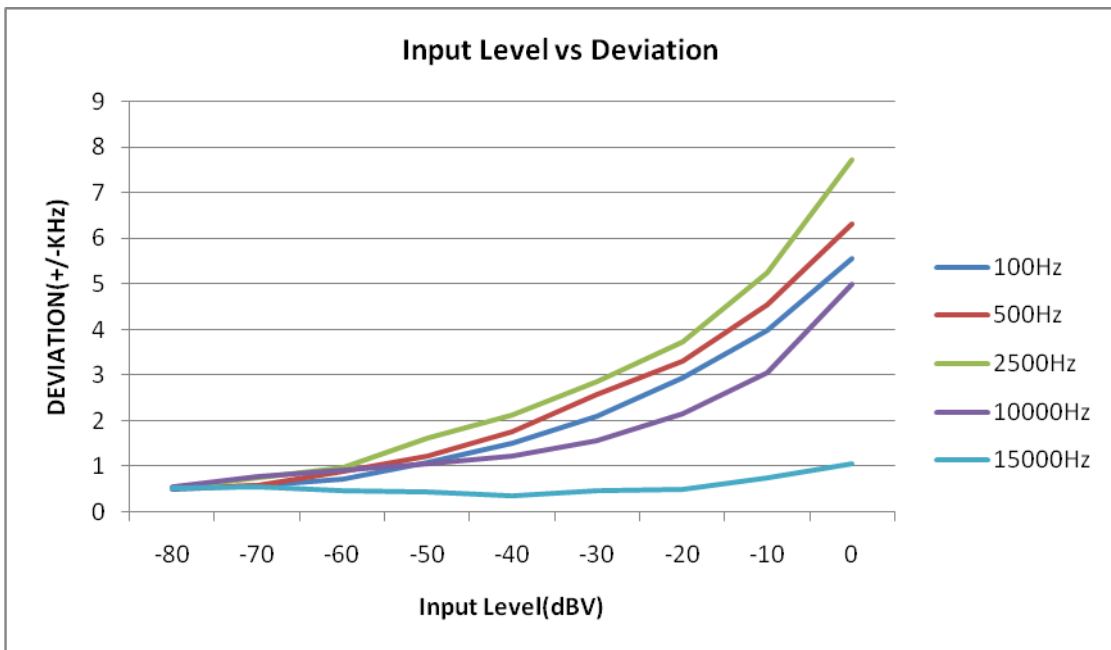
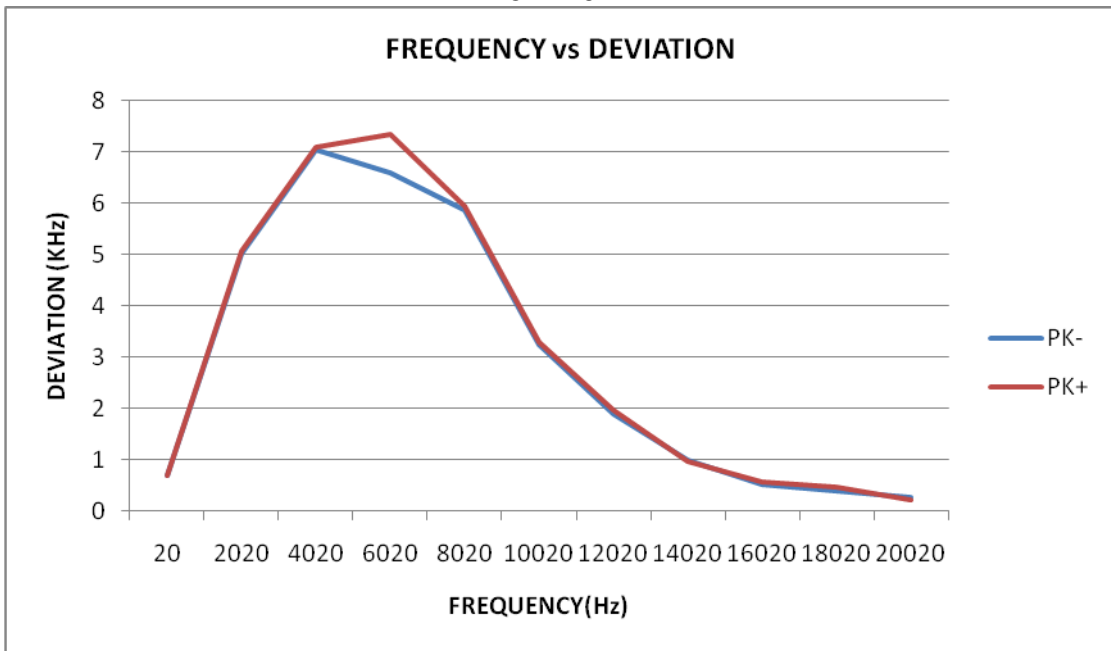

TX 595.66MHz

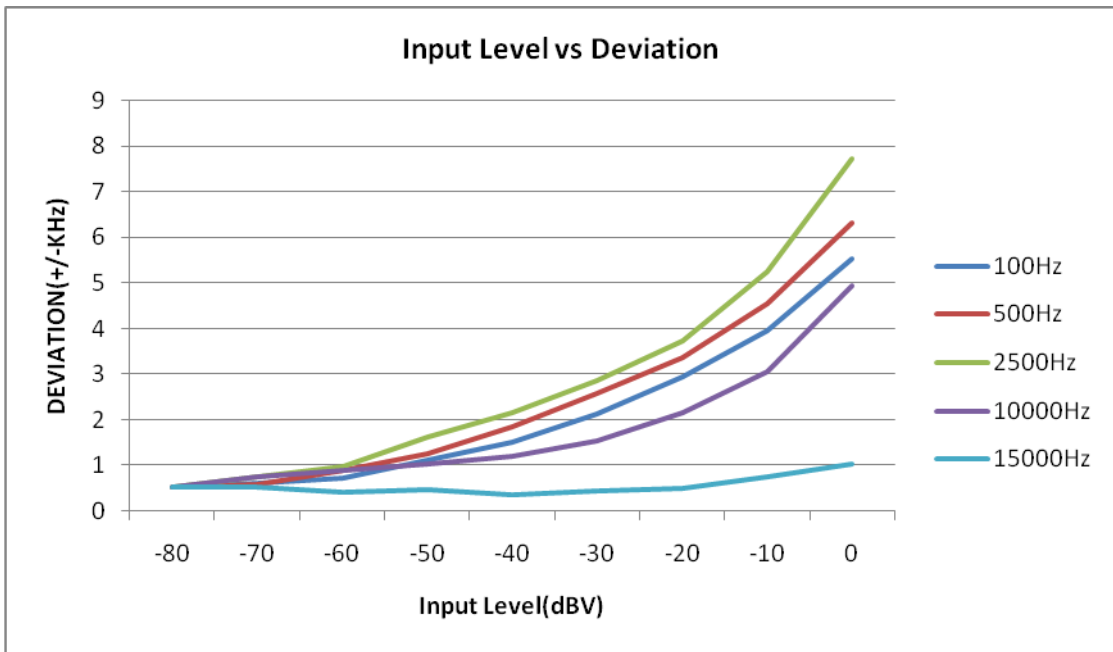
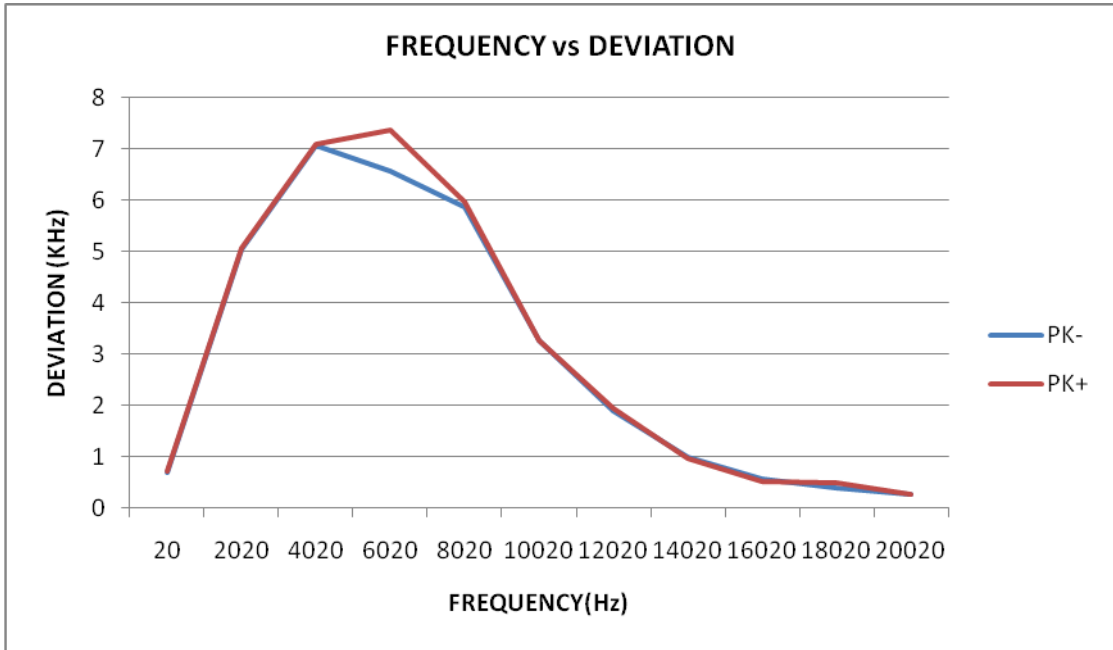

6. OCCUPIED BANDWIDTH OF EMISSION

6.1 APPLIED PROCEDURES / LIMIT

Test requirement: FCC CFR47 Part 2 Section 2.1049©(1)

Limit: According to FCC 74.861 (e)(5), the frequency emission bandwidth shall not exceed 200 kHz.

Occupied bandwidth 99%. Other than single sideband or independent sideband transmitters - when modulated by a 2500 Hz tone at an input level 16 dB greater than that necessary to produce 50 percent modulation.

The input level shall be established at the frequency of maximum response of the audio modulating circuit.

6.2 TEST PROCEDURE

1. Check the calibration of the measuring instrument using either an internal calibrator or a known signal from an external generator.
2. Turn on the EUT and set it to any one convenient frequency within its operating range.

Detector: Peak

Sweep time: Auto /

Resolution bandwidth: 1 % to 5 % of the occupied bandwidth

Video bandwidth: 3 x resolution bandwidth

Span: > 2 times emissions bandwidth

Analyzer function: 99% power occupied bandwidth function

Trace mode: Max. hold

EUT configuration: Modulated signal with max. frequency deviation

6.3 DEVIATION FROM STANDARD

No deviation.

6.4 TEST SETUP

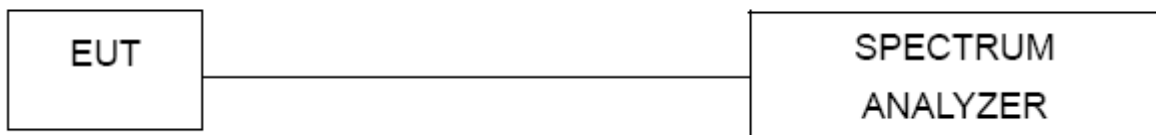

6.5 EUT OPERATION CONDITIONS

The EUT tested system was configured as the statements of 2.4 Unless otherwise a special operating condition is specified in the follows during the testing.

6.6 TEST RESULT

EUT :	Wireless Handheld Microphone Transmitter	Model Name :	WH-M1
Temperature :	25 °C	Relative Humidity :	60%
Pressure :	1012 hPa	Test Voltage :	DC 3V
Test Mode :	TX		

Frequency	99% Bandwidth (2.5kHz tone)	Limit (kHz)	Result
514.56 MHz	52.579	200	PASS
524.4 MHz	52.854	200	PASS
533.83MHz	52.264	200	PASS

Frequency	99% Bandwidth (2.5kHz tone)	Limit (kHz)	Result
534.56 MHz	52.125	200	PASS
544.49 MHz	56.077	200	PASS
595.66 MHz	54.414	200	PASS

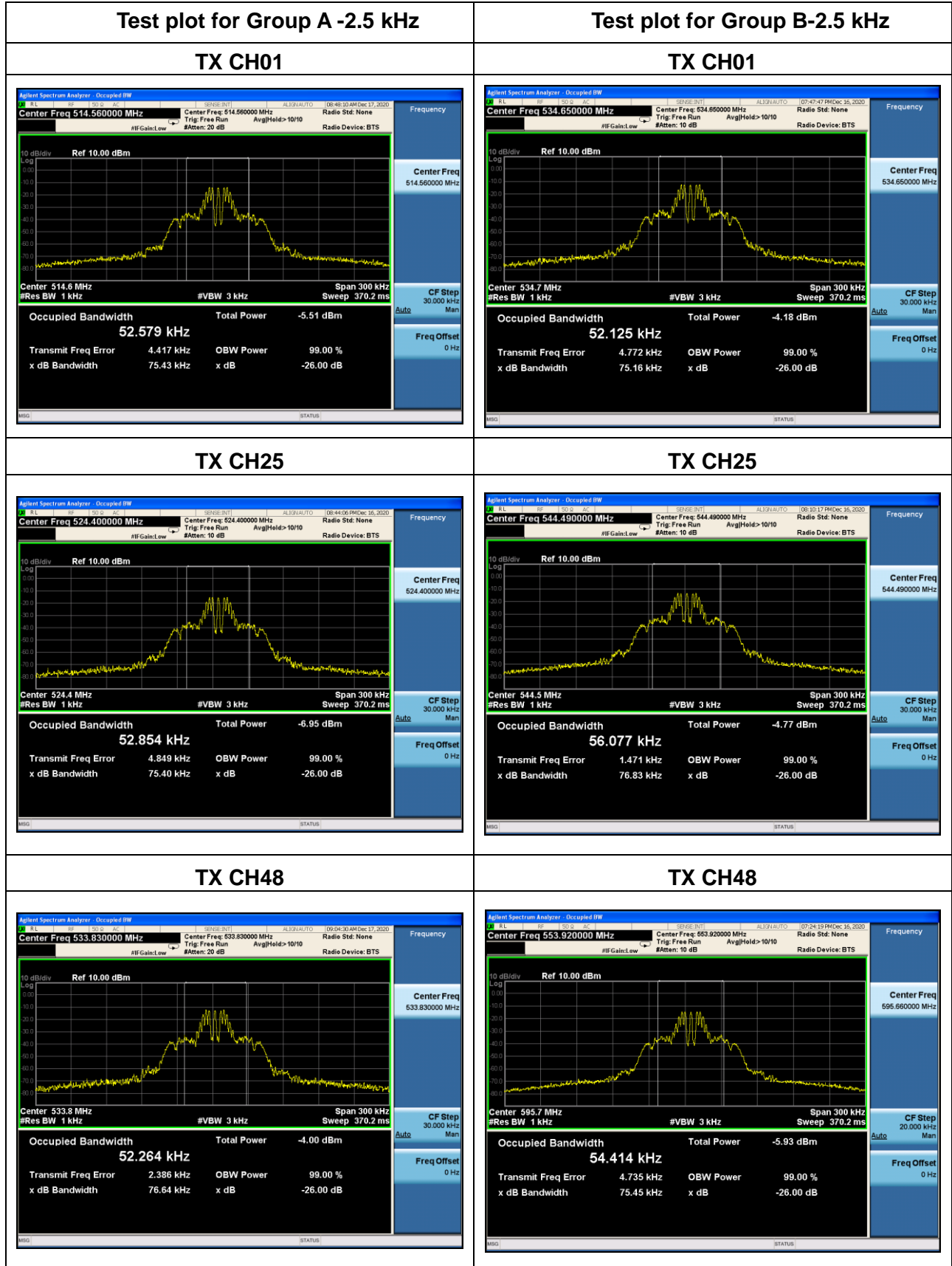

7. SPURIOUS EMISSIONS AT ANTENNA TERMINALS

Test requirement: FCC CFR47 Part 2 Section 2.1053

Test method: According to ANSI/TIA-603-E: 2016 section 2.2.13,

Limit: According to Part 74.861 (e)(6), the mean power of emissions shall be attenuated below the mean output power of the transmitter in accordance with the following schedule:

(i) on any frequency removed from the operating frequency by more than 50 percent up to and including 100 percent of the authorized bandwidth: at least 25 dB.

(ii) on any frequency removed from the operating frequency by more than 100 percent up to and including 250 percent of the authorized bandwidth: at least 35 dB.

(iii) on any frequency removed from the operating frequency by more than 250 percent up to and the authorized bandwidth shall be attenuated below the un-modulated carrier by at least $43 + 10 \text{ Log} (\text{output power in watts})\text{dB}$.

7.1 TEST PROCEDURE

1. Turn on the EUT and connect its antenna terminal to measurement instrument via a low loss cable. Then set it to any one measured frequency within its operating range, and make sure the instrument is operated in its linear range.
2. Set the SA on Max-Hold Mode, and then keep the EUT in transmitting mode. Record all the signals from each channel until each one has been recorded.
3. Set the SA on View mode and then plot the result on SA screen.
4. Repeat above procedures until all frequencies measured were complete.

Detector: Peak

Sweep time: Auto /

Resolution bandwidth: 25 dBc and 35 dB-criteria: 1% of the authorized bandwidth

55+10log₁₀(P_{MEAN} inWatts) dB - criteria 30 kHz

43+10log₁₀(P_{MEAN} inWatts) dB - criteria 120 kHz /1 MHz

Video bandwidth: 3 x resolution bandwidth

Span: > 2 times emissions bandwidth

Trace mode: Max. hold

EUT configuration: Modulated signal with max. frequency deviation

7.2 EUT OPERATION CONDITIONS

The EUT tested system was configured as the statements of 2.4 Unless otherwise a special operating condition is specified in the follows during the testing.

7.3 TEST RESULTS

EUT :	Wireless Handheld Microphone Transmitter	Model Name :	WH-M1
Temperature :	25 °C	Relative Humidity :	56%
Pressure :	1012 hPa	Test Voltage :	DC 3V
Test Mode :	TX		

Test plot for Group A -1 kHz

TX CH01

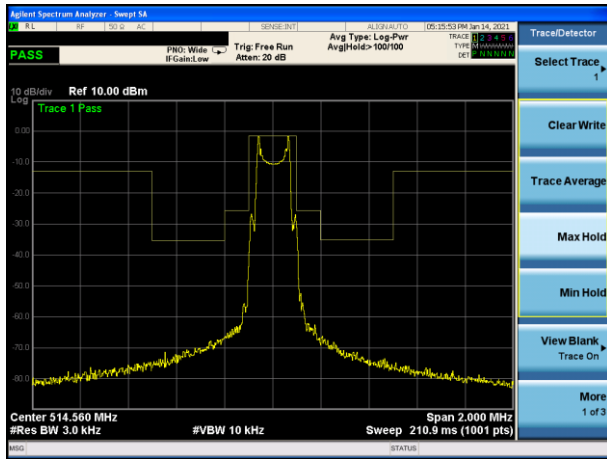

Test plot for Group B-1 kHz

TX CH01

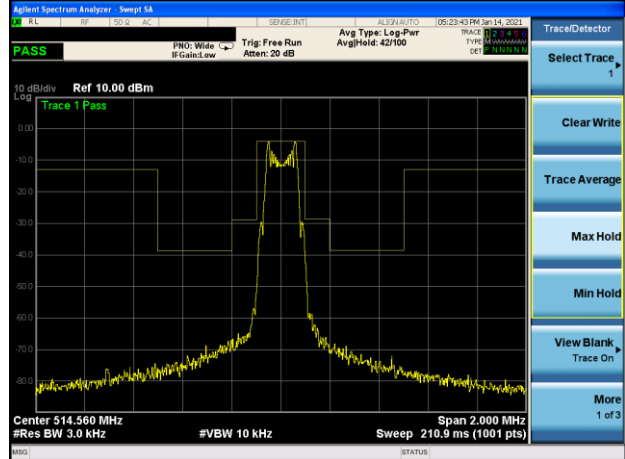

TX CH25

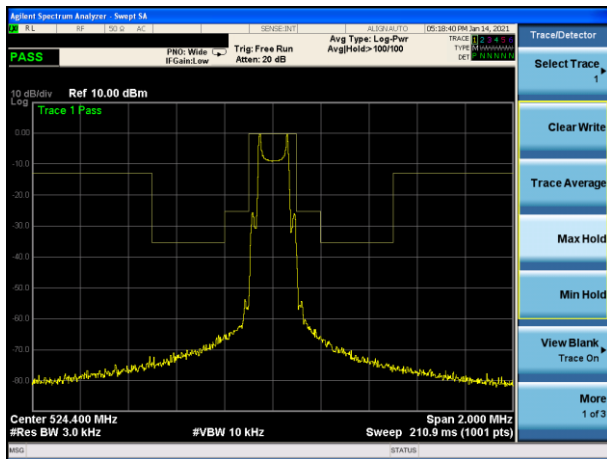

TX CH25

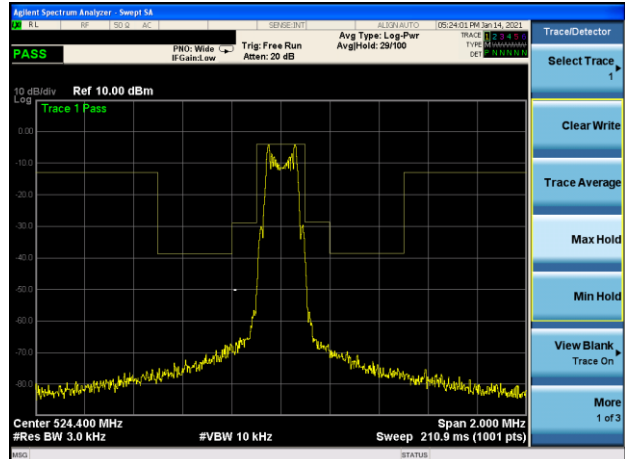

TX CH48

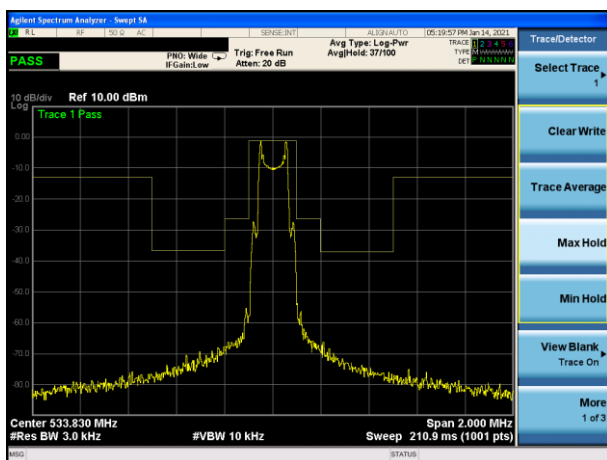

TX CH48

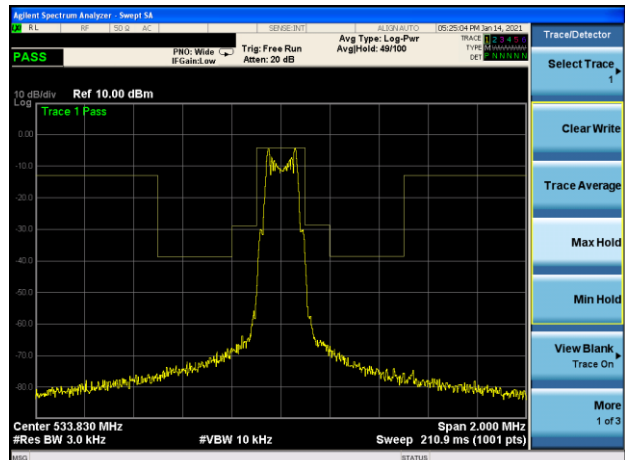

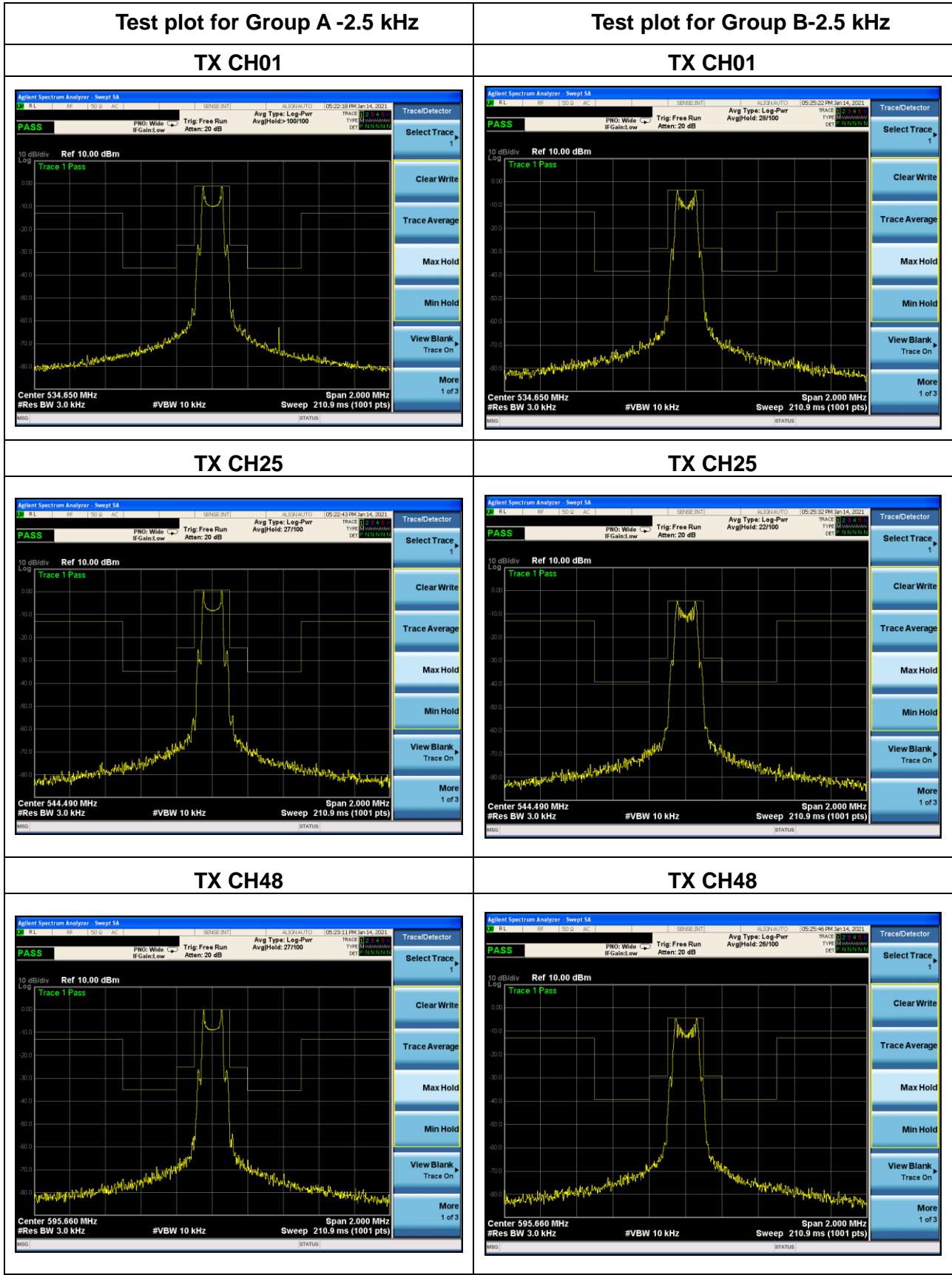

Conducted Spurious Emissions

Test plot for Group A

TX CH01(30MHz-1GHz)

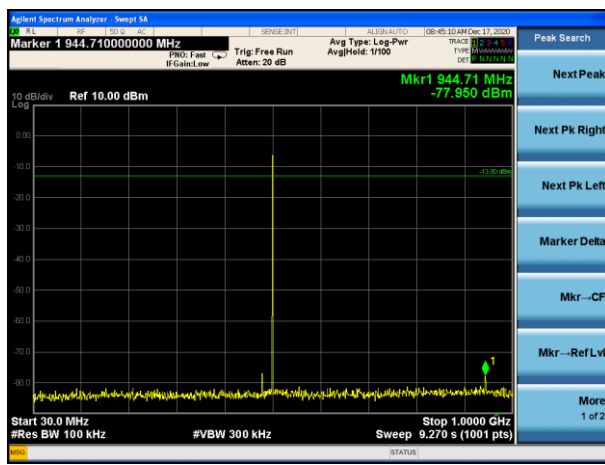

TX CH01(1GHz-7GHz)



TX CH25(30MHz-1GHz)

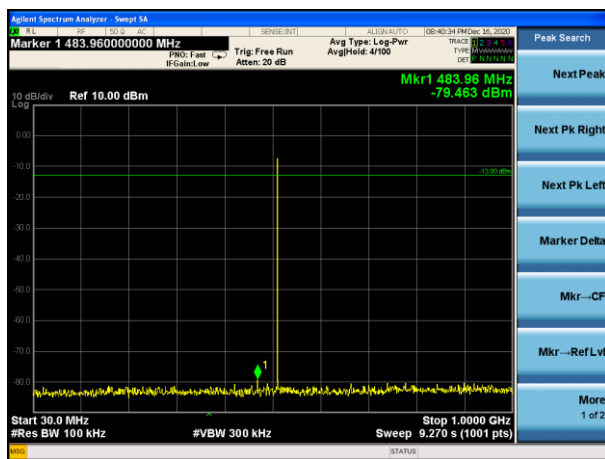

TX CH25(1GHz-7GHz)



TX CH48(30MHz-1GHz)

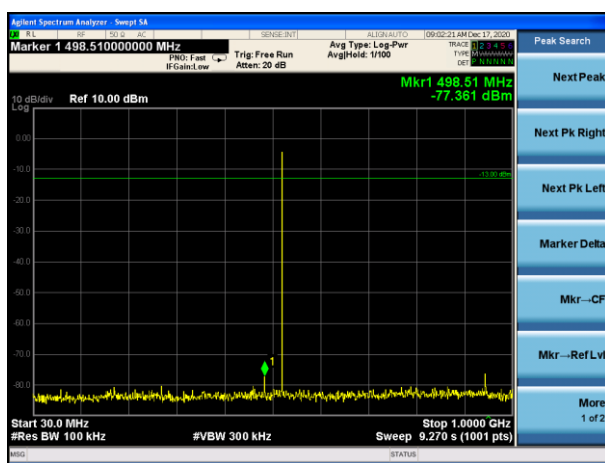

TX CH48(1GHz-7GHz)



Test plot for Group B

TX CH01(30MHz-1GHz)

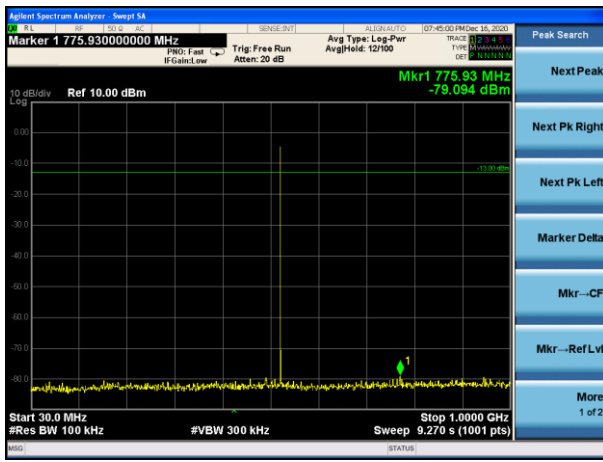

TX CH01(1GHz-7GHz)



TX CH25(30MHz-1GHz)

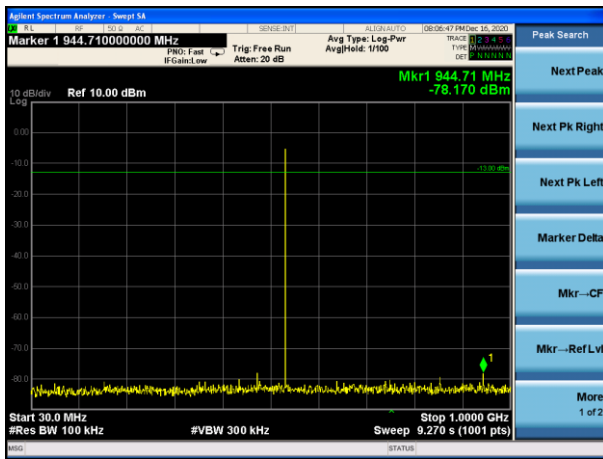

TX CH25(1GHz-7GHz)

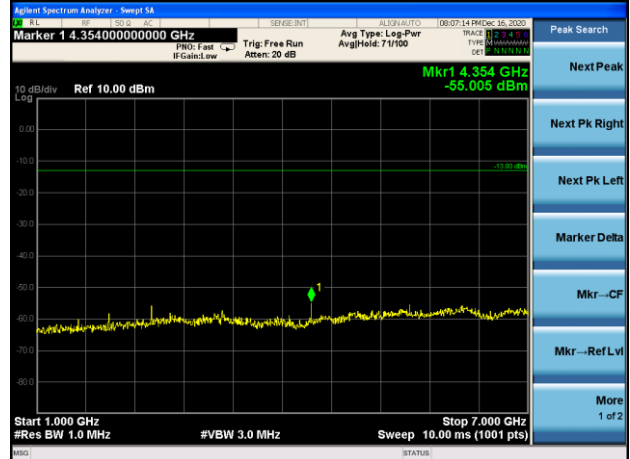

TX CH48(30MHz-1GHz)

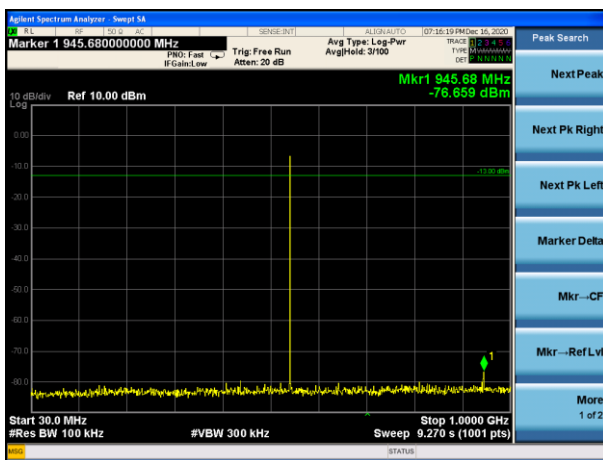

TX CH48(1GHz-7GHz)



8. FREQUENCY STABILITY

8.1 STANDARD REQUIREMENT

Test requirement: FCC CFR47 Part 2 Section 2.1055(a)(a)

Test method: ANSI/TIA-603-E: 2016 section 2.2.2

Limit: According to FCC 74.86(e)(4), the frequency tolerance of the transmitter shall be 0.005 percent.

8.2 TEST CONFIGURATION

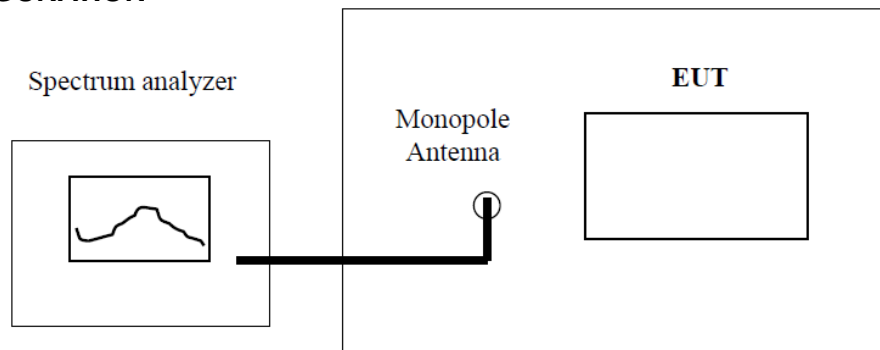

8.3 TEST PROCEDURE

A) Frequency stability versus input voltage

1. An external variable DC power supply was connected to the battery terminals of the equipment under test.
2. For hand carried, battery powered equipment primary supply voltage was reduced to the battery operating end point as specified by the manufacturer. The output frequency was recorded for each battery voltage.

Detector:	Peak
Sweep time:	Auto /
Resolution bandwidth:	1 Hz / 10 Hz / 100 Hz
Video bandwidth:	3 x resolution bandwidth
Span:	wide enough to follow the frequency drift
Trace mode:	clear/write/view
EUT configuration:	CW signal or MC with measurement method description

B) Frequency stability versus environmental temperature

1. Setup the configuration per figure 1 for frequencies measured at an environmental chamber, Install new batteries in the EUT.
2. Turn on EUT and set SA center frequency to the EUT operation frequency, then set SA RBW to 30kHz, VBW to 100kHz and frequency span to 500 kHz. Record this frequency to be a reference.
3. Set the temperature of chamber to 50°C. Allow sufficient time (approximately 30 min) for the temperature of the chamber to stabilize. While maintaining a constant temperature inside the chamber, turn the EUT on and measure the EUT operating frequency.
4. Repeat step 2 with a 10°C decreased per stage until the lowest temperature -30°C is measured, record all measurement frequencies.

8.4 TEST RESULT

Test data for Group A

a) Frequency stability versus input voltage

Power Supply	Reference Frequency (MHz)	Environment Temperature (°C)	Frequency Measured	Frequency Tolerance (%)
DC 3.15V	514.56	20	514.569	0.0017%
DC 4.25V	514.56	20	514.567	0.0014%
DC 3.15V	524.4	20	524.403	0.0006%
DC 4.25V	524.4	20	524.405	0.0010%
DC 3.15V	533.83	20	533.833	0.0006%
DC 4.25V	533.83	20	533.839	0.0017%

b) Frequency stability versus environmental temperature

514.56MHz

Environment Temperature(°C)	Power Supply	Frequency Deviation measured with time Elapse(30 minutes)	
		MHz	%
50	DC 3V	514.567	0.0014%
40	DC 3V	514.568	0.0016%
30	DC 3V	514.564	0.0008%
20	DC 3V	514.563	0.0006%
10	DC 3V	514.566	0.0012%
0	DC 3V	514.567	0.0014%
-10	DC 3V	514.564	0.0008%
-20	DC 3V	514.567	0.0014%
-30	DC 3V	514.563	0.0006%

524.4MHz

Environment Temperature(°C)	Power Supply	Frequency Deviation measured with time Elapse(30 minutes)	
		MHz	%
50	DC 3V	524.402	0.0004%
40	DC 3V	524.401	0.0002%
30	DC 3V	524.403	0.0006%
20	DC 3V	524.403	0.0006%
10	DC 3V	524.402	0.0004%
0	DC 3V	524.404	0.0008%
-10	DC 3V	524.405	0.0010%
-20	DC 3V	524.404	0.0008%
-30	DC 3V	524.405	0.0010%

533.83MHz

Environment Temperature(°C)	Power Supply	Frequency Deviation measured with time Elapse(30 minutes)	
		MHz	%
50	DC 3V	533.836	0.0011%
40	DC 3V	533.831	0.0002%
30	DC 3V	533.829	-0.0002%
20	DC 3V	533.831	0.0002%
10	DC 3V	533.832	0.0004%
0	DC 3V	533.833	0.0006%
-10	DC 3V	533.831	0.0002%
-20	DC 3V	533.833	0.0006%
-30	DC 3V	533.831	0.0002%

Test data for Group B

a) Frequency stability versus input voltage

Power Supply	Reference Frequency (MHz)	Environment Temperature (°C)	Frequency Measured	Frequency Tolerance (%)
DC 3.15V	534.65	20	534.659	0.0017%
DC 4.25V	534.65	20	534.657	0.0013%
DC 3.15V	544.49	20	544.493	0.0006%
DC 4.25V	544.49	20	544.495	0.0009%
DC 3.15V	595.66	20	595.663	0.0005%
DC 4.25V	595.66	20	595.669	0.0015%

b) Frequency stability versus environmental temperature

534.56MHz

Environment Temperature(°C)	Power Supply	Frequency Deviation measured with time Elapse(30 minutes)	
		MHz	%
50	DC 3V	534.651	0.0002%
40	DC 3V	534.652	0.0004%
30	DC 3V	534.653	0.0006%
20	DC 3V	534.654	0.0007%
10	DC 3V	534.655	0.0009%
0	DC 3V	534.656	0.0011%
-10	DC 3V	534.652	0.0004%
-20	DC 3V	534.657	0.0013%
-30	DC 3V	534.653	0.0006%

544.49MHz

Environment Temperature(°C)	Power Supply	Frequency Deviation measured with time Elapse(30 minutes)	
		MHz	%
50	DC 3V	544.491	0.0002%
40	DC 3V	544.499	0.0017%
30	DC 3V	544.495	0.0009%
20	DC 3V	544.493	0.0006%
10	DC 3V	544.496	0.0011%
0	DC 3V	544.494	0.0007%
-10	DC 3V	544.498	0.0015%
-20	DC 3V	544.494	0.0007%
-30	DC 3V	544.495	0.0009%

5395.66MHz

Environment Temperature(°C)	Power Supply	Frequency Deviation measured with time Elapse(30 minutes)	
		MHz	%
50	DC 3V	595.663	0.0005%
40	DC 3V	595.664	0.0007%
30	DC 3V	595.665	0.0008%
20	DC 3V	595.669	0.0015%
10	DC 3V	595.667	0.0012%
0	DC 3V	595.669	0.0015%
-10	DC 3V	595.668	0.0013%
-20	DC 3V	595.663	0.0005%
-30	DC 3V	595.661	0.0002%

9. NECESSARY BANDWIDTH (BN) FOR ANALOGUE SYSTEMS

9.1 APPLIED PROCEDURES / LIMIT

Test requirement: FCC 74.861 (e)(7)

Figure 3 shows the spectrum mask for all analogue systems in the band. The -90 dBc point shall be ± 1 MHz from f_c measured with an average detector. To comply, a measured value shall fall below the mask limit as shown in figure 3.

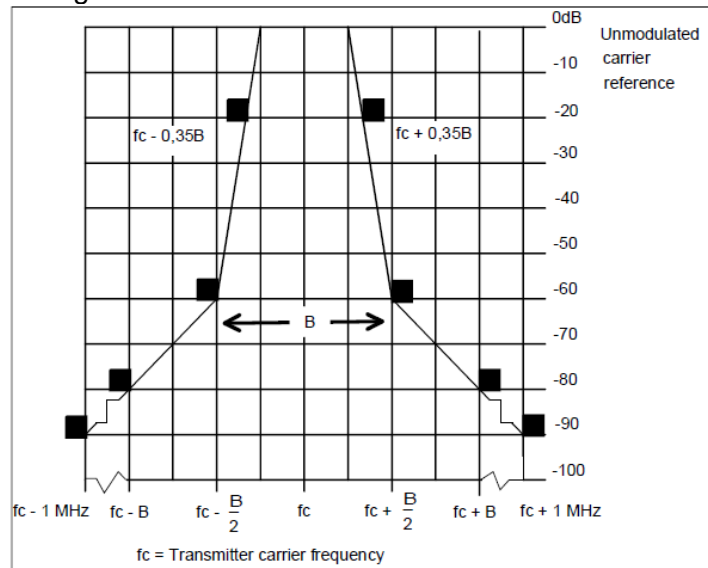

Figure 3: Spectrum mask for analogue systems in all bands

9.2 TEST PROCEDURE

The arrangement of test equipment as shown in figure B.1 shall be used. Note that the noise meter conforms to (quasi peak) without weighting filter (flat).
 With the Low Frequency (LF) audio signal generator set to 500 Hz, the audio input level to the EUT shall be adjusted to 8 dB below the limiting threshold (-8 dB (lim)) as declared by the manufacturer. The corresponding audio output level from the demodulator shall be measured and recorded.
 The input impedance of the noise meter shall be sufficiently high to avoid more than 0,1 dB change in input level when the meter is switched between input and output.
 The audio input level shall be increased by 20 dB, i.e. to +12 dB (lim), and the corresponding change in output level shall be measured.
 It shall be checked that the audio output level has increased by ≤ 10 dB.
 If this condition is not met, the initial audio input level shall be increased from -8 dB (lim) in 1 dB steps until the above condition is fulfilled, and the input level recorded in the test report. This level replaces the value derived from the manufacturer's declaration and is defined as -8 dB (lim).
 Measure the input level at the transmitter required to give +12 dB (lim).
 The LF generator shall be replaced with the weighted noise source to Recommendation ITU-R BS.559-2 [1], band-limited to 15 kHz as described in IEC 60244-13 [2], and the level shall be adjusted such that the measured input to the transmitter corresponds to +12 dB (lim).

If the transmitter incorporates any ancillary coding or signalling channels (e.g. pilot-tones), these shall be enabled prior to any spectral measurements.

If the transmitter incorporates more than one audio input, e.g. stereo systems, the second and subsequent channels shall be simultaneously driven from the same noise source, attenuated to a level of -6 dB (lim).

The transmitter RF output spectrum shall be measured, using a spectrum analyser with the following settings:

- centre frequency: f_c : Transmitter (Tx) nominal frequency;
- dispersion (Span): $f_c - 1$ MHz to $f_c + 1$ MHz;
- Resolution BandWidth (RBW): 1 kHz;
- Video BandWidth (VBW): 1 kHz;
- detector: Peak hold.

9.3 DEVIATION FROM STANDARD

No deviation.

9.4 TEST SETUP

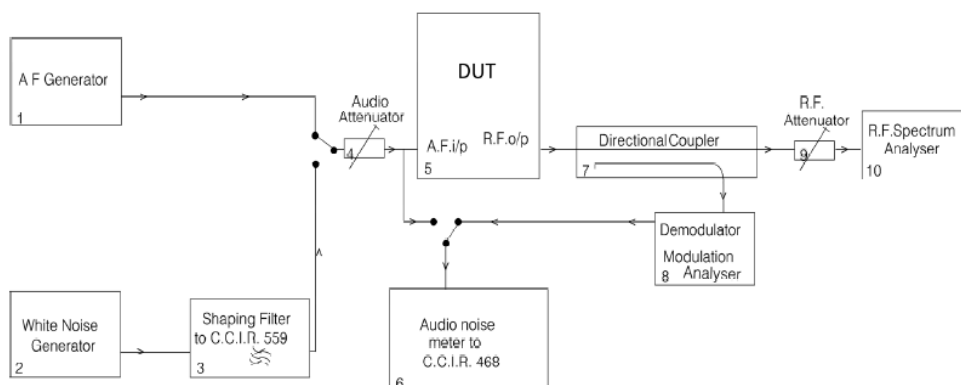

NOTE: If the DUT incorporates ancillary coding or signalling channels, for example, pilot tone, etc. these should be switched on prior to measuring the transmitter RF output spectrum.

9.5 EUT OPERATION CONDITIONS

The EUT tested system was configured as the statements of 2.4 Unless otherwise a special operating condition is specified in the follows during the testing.

9.6 TEST RESULT

EUT :	Wireless Handheld Microphone Transmitter	Model Name :	WH-M1
Temperature :	25 °C	Relative Humidity :	60%
Pressure :	1012 hPa	Test Voltage :	DC 3V
Test Mode :	TX		

B=100kHz

514.56MHz Test Plot

The carrier without modulation

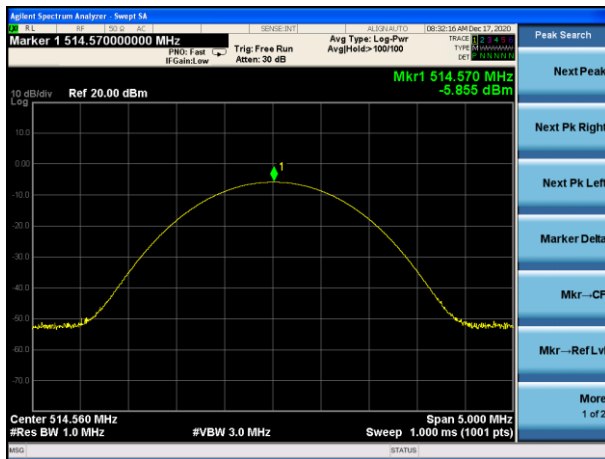

Test Plot-The Peak figure with modulation

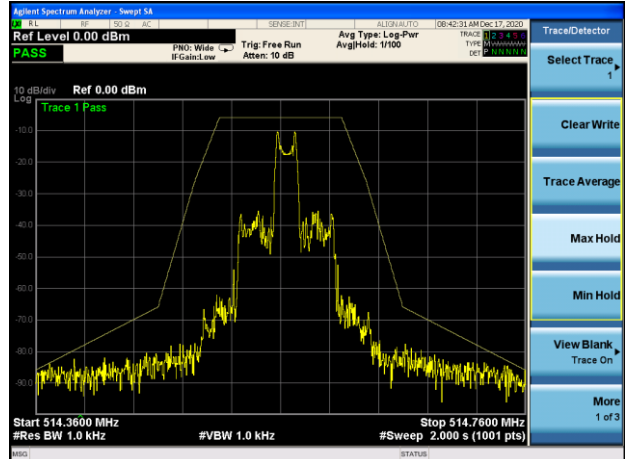

The Average figure with modulation
(fc-1MHz~fc-B)

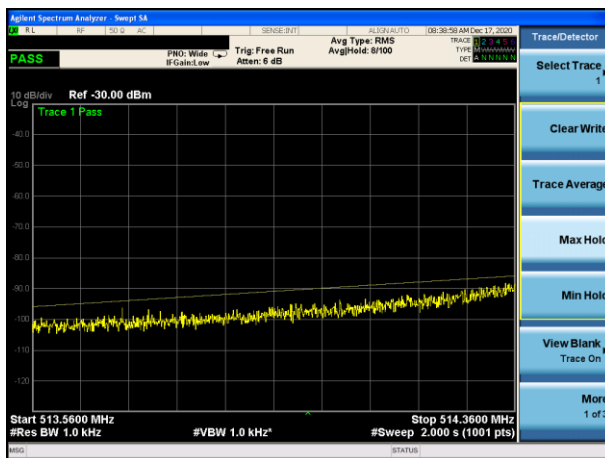

The Average figure with modulation
(fc+B ~ fc+1MHz)

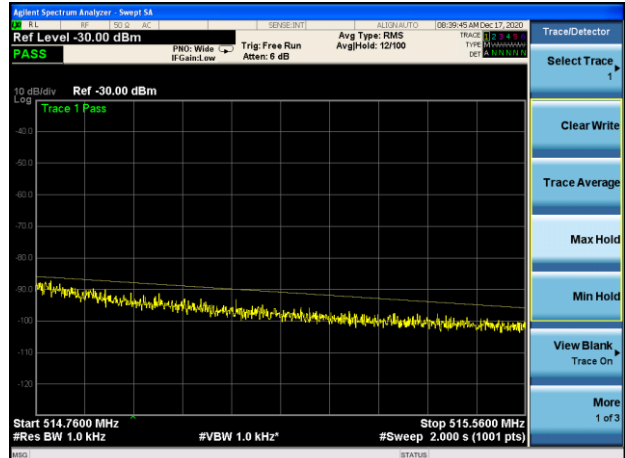

524.4MHz MHz Test Plot

The carrier without modulation

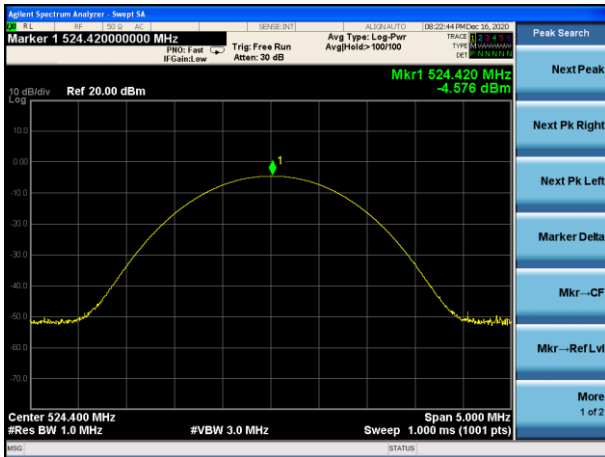

Test Plot-The Peak figure with modulation

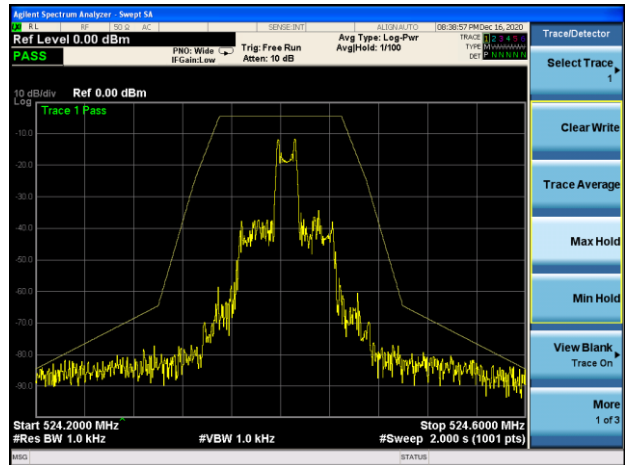

The Average figure with modulation
($f_c - 1\text{MHz} \sim f_c - B$)

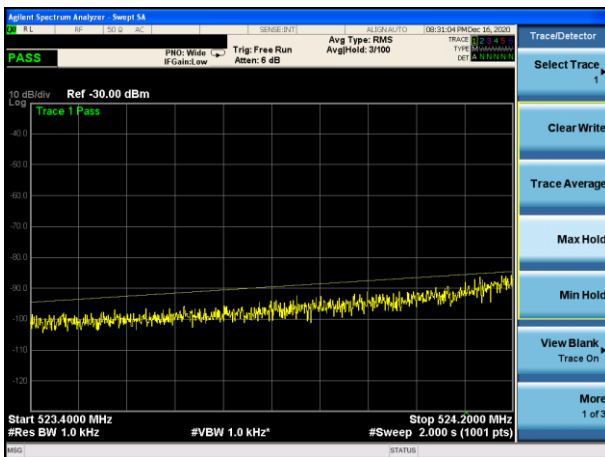

The Average figure with modulation
($f_c + B \sim f_c + 1\text{MHz}$)

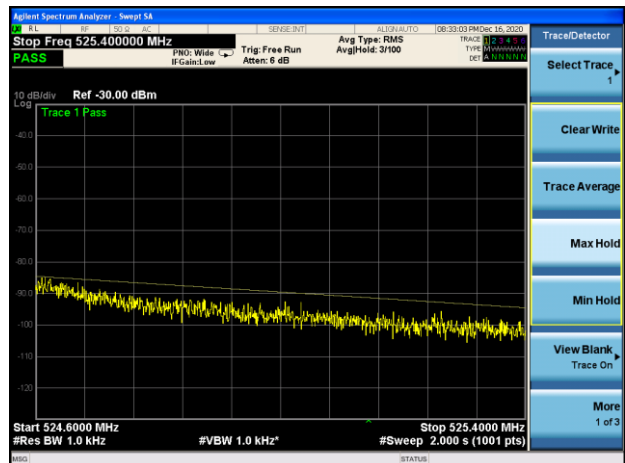

533.83MHz MHz Test Plot

The carrier without modulation

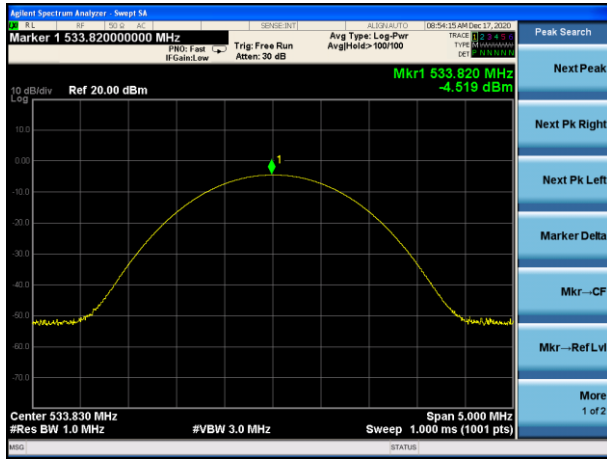

Test Plot-The Peak figure with modulation

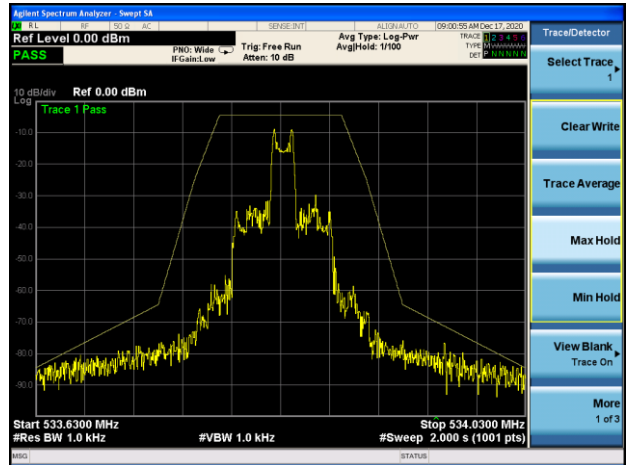

The Average figure with modulation
(fc-1MHz~fc-B)

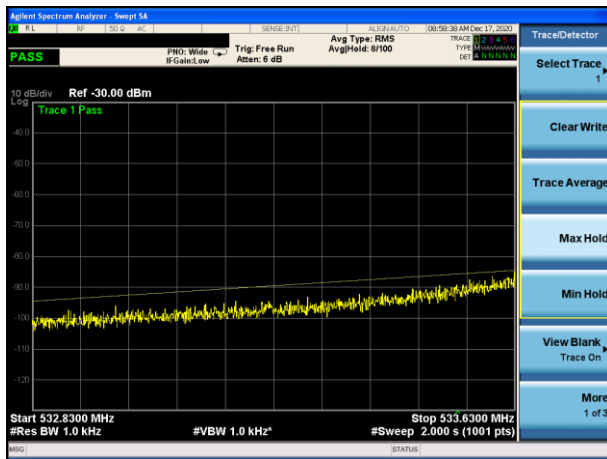

The Average figure with modulation
(fc+B ~ fc+1MHz)

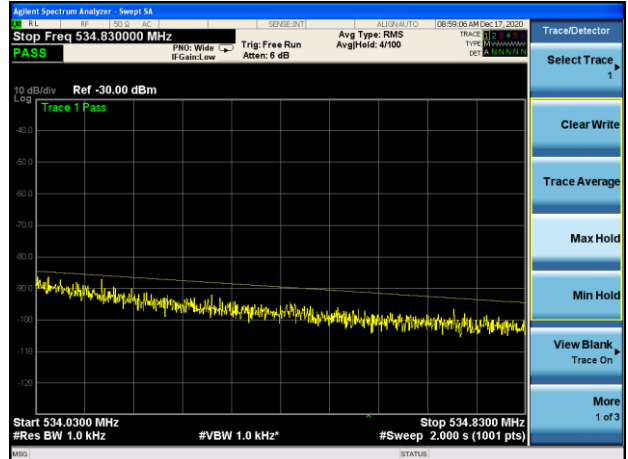

534.65MHz Test Plot

The carrier without modulation

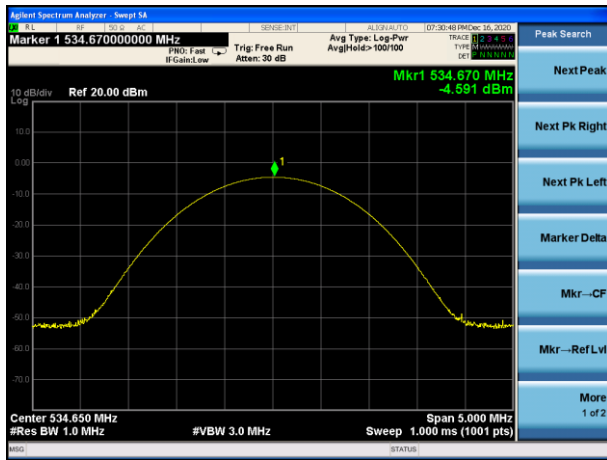

Test Plot-The Peak figure with modulation

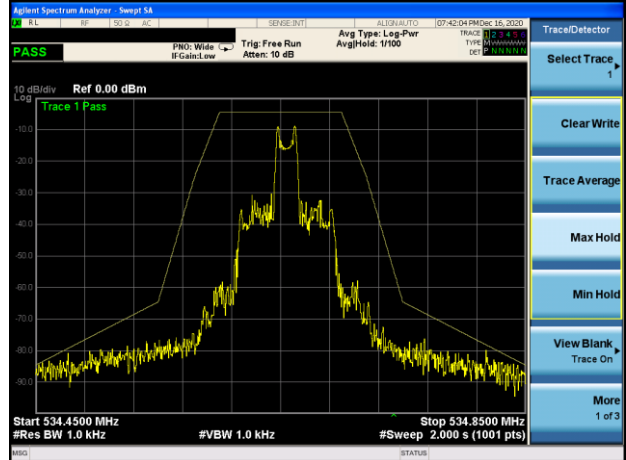

The Average figure with modulation
(fc-1MHz~fc-B)

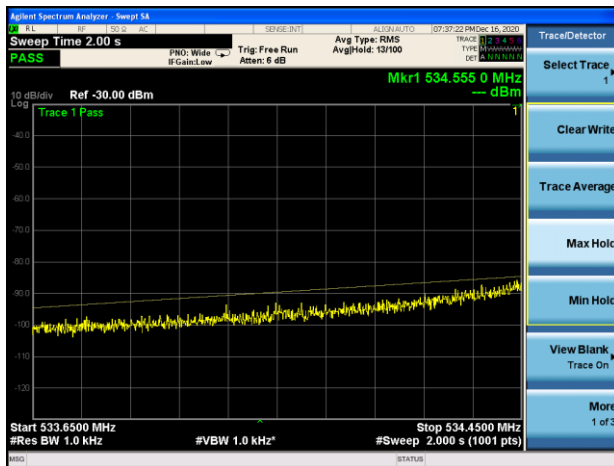

The Average figure with modulation
(fc+B ~ fc+1MHz)

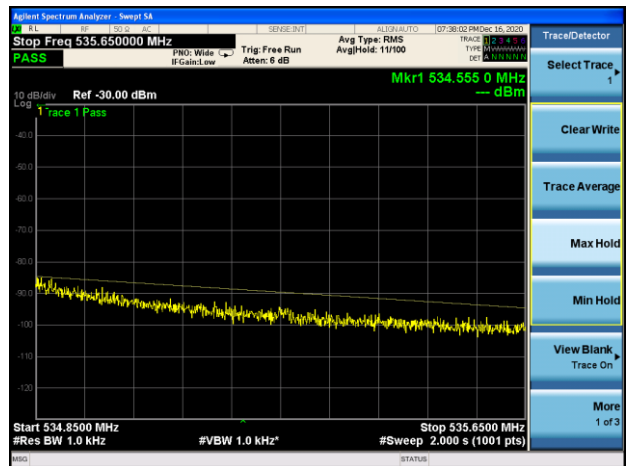

544.49MHz Test Plot

The carrier without modulation

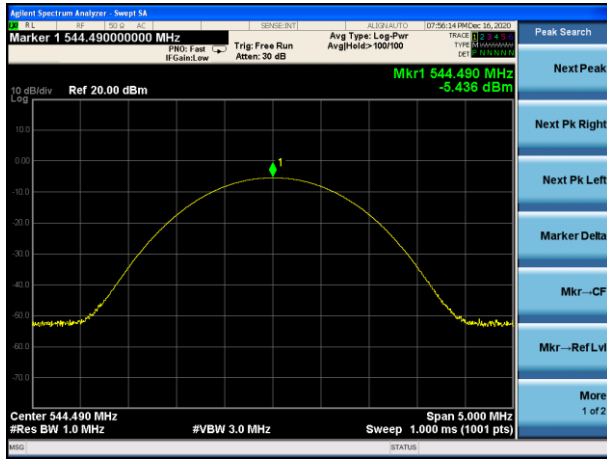

Test Plot-The Peak figure with modulation

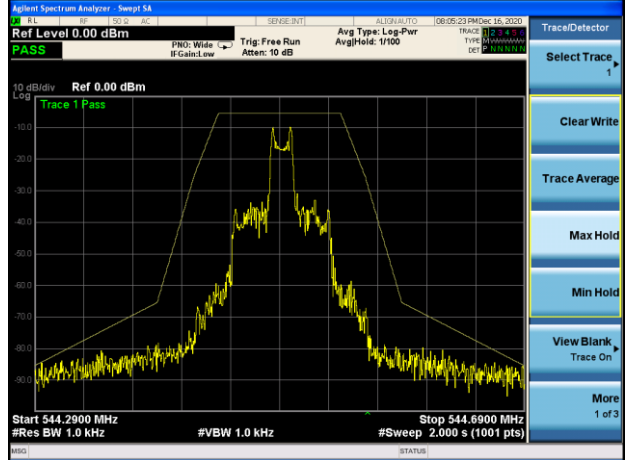

The Average figure with modulation
(fc-1MHz~fc-B)

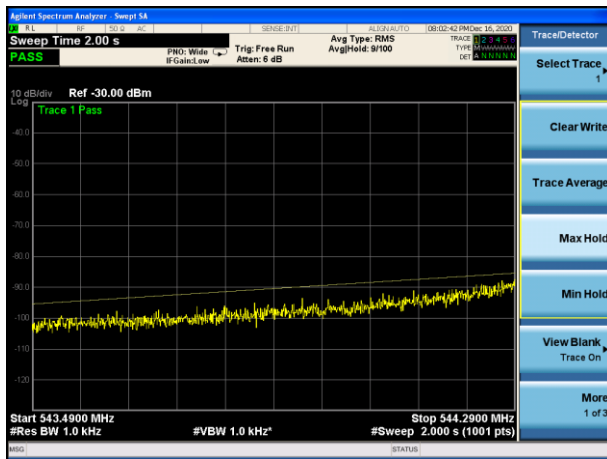

The Average figure with modulation
(fc+B ~ fc+1MHz)

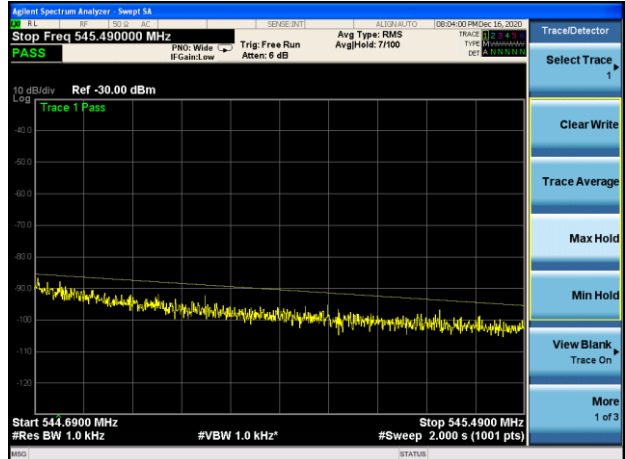

595.66MHz Test Plot

The carrier without modulation

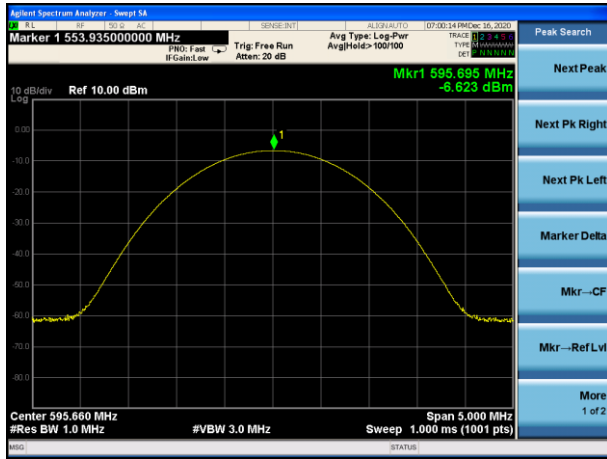

Test Plot-The Peak figure with modulation

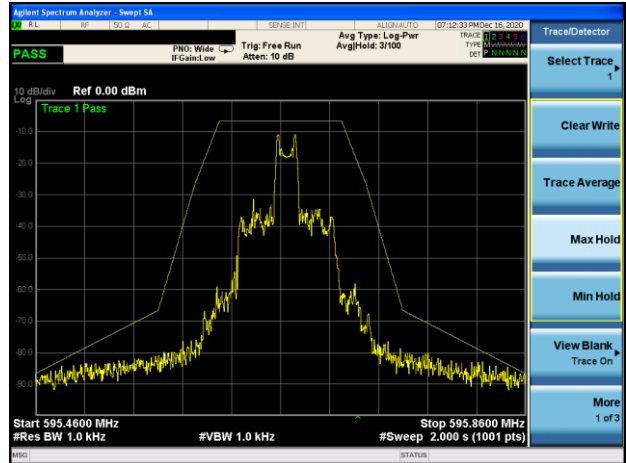

The Average figure with modulation (fc-1MHz~fc-B)

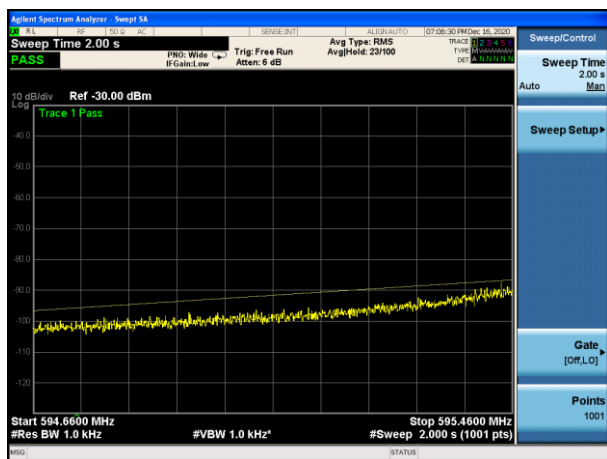

The Average figure with modulation (fc+B ~ fc+1MHz)

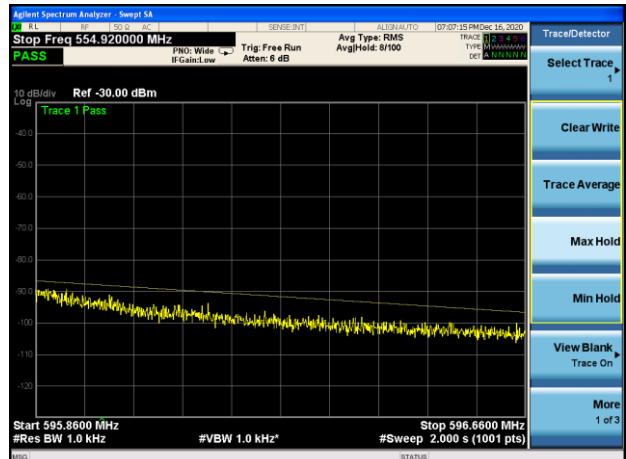

10. EUT TEST PHOTO

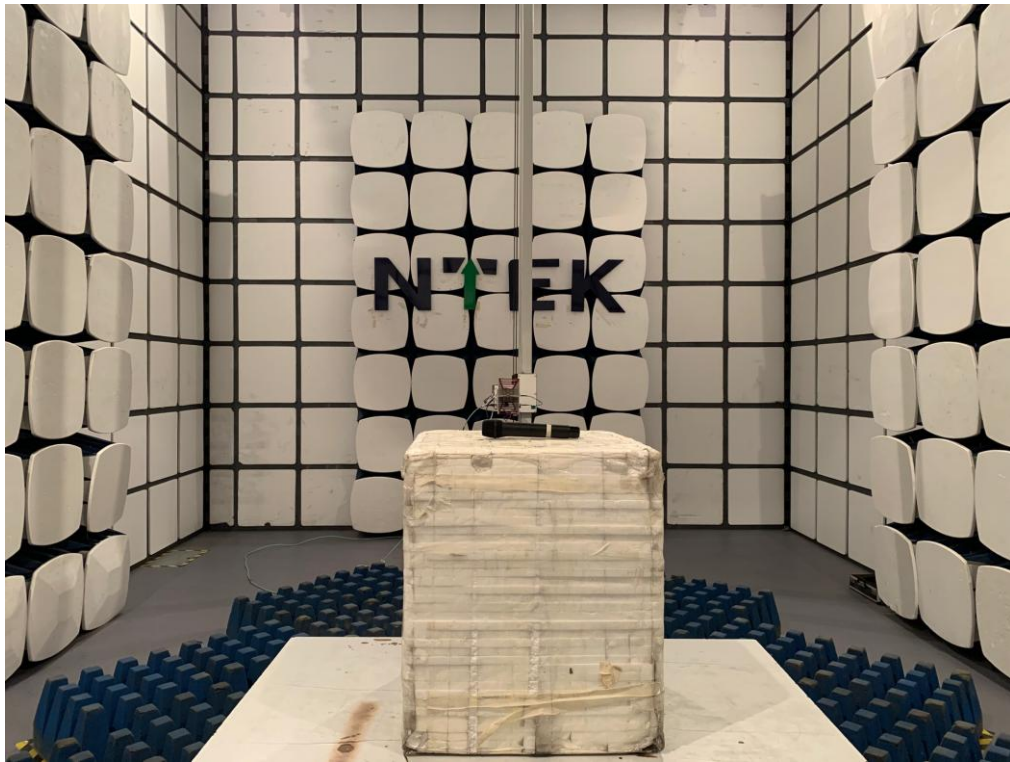
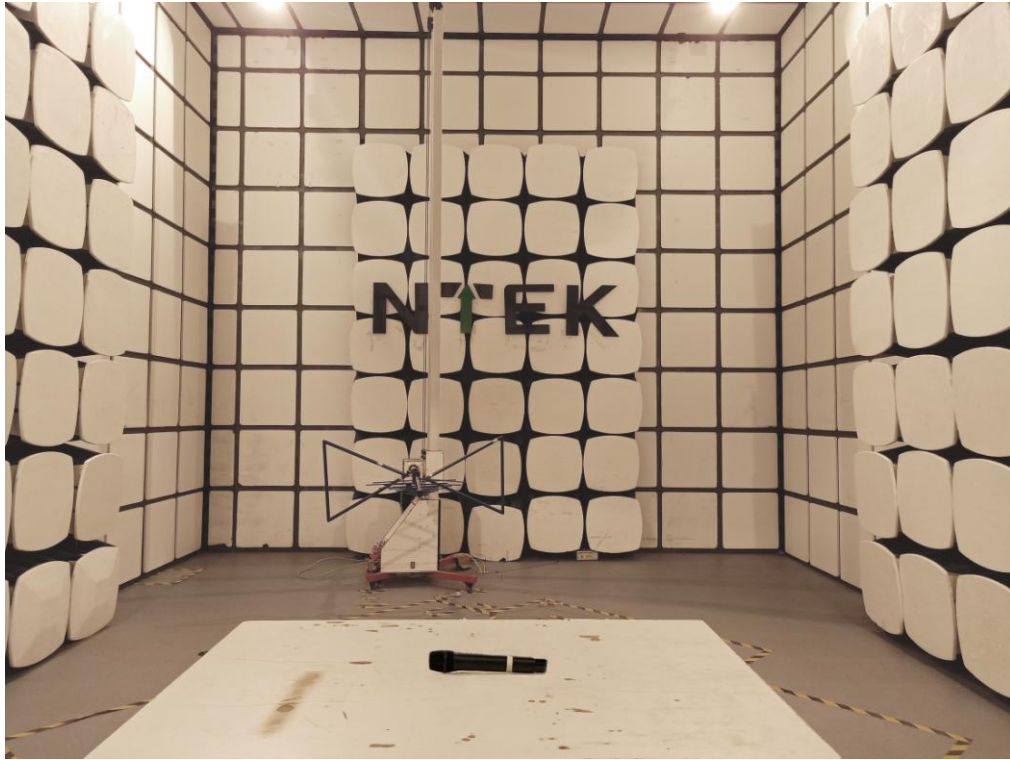

----- End of Report -----