

规格承认书

Specification for Approval

客户: _____
 Customer: _____
 客户料号: _____
 Customer Part No.: _____
 供应商: 伏达半导体（合肥）有限公司
 Supplier: _____
 规格描述: _____
 Spec description: _____
 供应商料号: J-FDIMPP
 Supplier Part No.: _____
 日期: 2023/6/1
 Date: _____
 版本: A.0
 Version: _____
 制作: _____
 Draw: _____

供应商确认 Supplier Approve		客户确认 Customer Approve
研发确认 EE Confirm by	工程确认 PE Confirm by	
品质确认 QE Confirm by	批准 Approval by	

1. 生产商信息 Manufacturer information

项目 Items	生产商名称 Manufacturer name	生产商确认 Approval
第一资源 The first resource	吉欧	罗杰
第二资源 The second resource		

2. 尺寸规格 Dimension specification

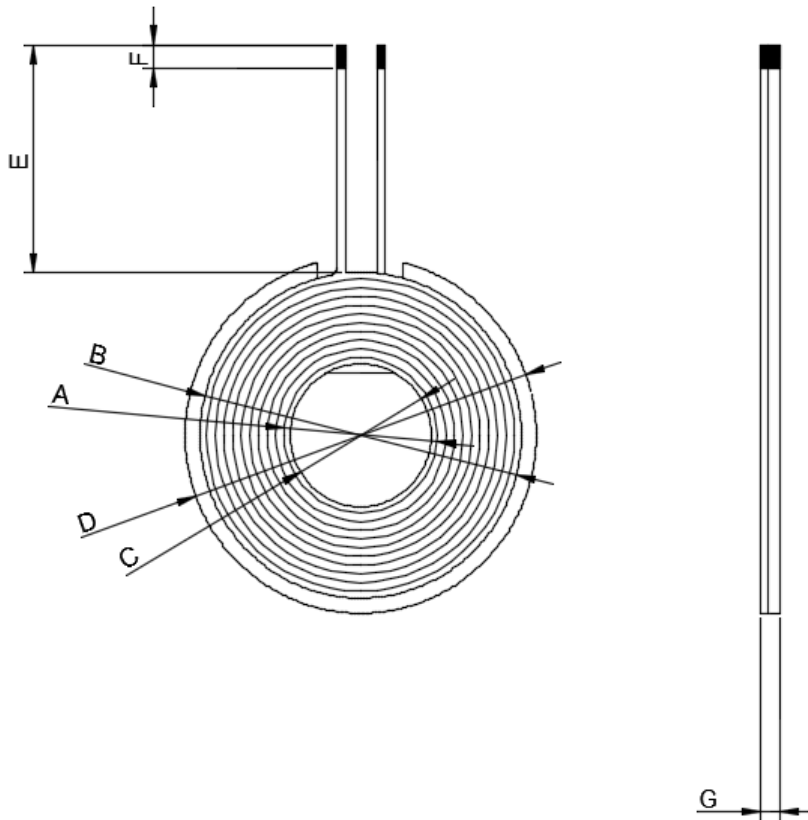

单位(Unit):毫米(mm)

A	B	C	D	E	F	G
20.5±0.5	39±1	19.5±0.3	42.5±0.5	8±1	4±1.5	2.05±0.1

注：
Note:

- 线圈引线处不贴高温胶带
Do not attach high-temperature tape to coil leads
- 线圈与隔磁片贴合时不得高出隔磁片的边沿
The coil shall not be higher than the edge of the separator when it is fitted to the separator

3.原理图 Schematic diagram

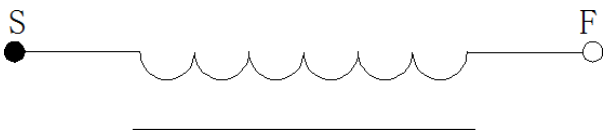

4.电器特性 Electronic character

温度 TEMPERATURE:25±10°C,湿度 RELATIVE HUMIDITY :65±20%

项目 TIEM	标准 SPECIFICATION	测试条件 TEST FREQUENCY	测试仪器 TEST EQUIPMENTS
IND	8.4UH±10%	100 KHZ/1.0V	LCRMETRTH2830N
DCR	50mΩ Max	\	PH2511S
Q	100±10%	100 KHZ/1.0V	LCRMETRTH2830N

5.线圈参数 Coil specification

圈数 Turns	线径 Wire Dia.	绕线方式疏/密 Wdg. Type Spred/Close	绕线方向 Wdg.Direction	相交是/否 Intersect Yes/Not	线圈正/反贴 Coil Positive/Anti Paste
11T S	0.08*80P 热风绞线 (Silk-Covered Wire)	密绕 (Close)	逆时针 (Anticlockwise)	相交 (Yes)	反贴 (Anti-/Paste)

6.材料清单 Bill of materials

序号 number	材料名称 Material name	品名描述 Description	物料代码 Material Code
1	线材 Wire rod	0.08*80P 热风绞线 Hot air strand	
2	硬磁片 Hard disk	G42.5*19.5*2.0H (冠型磁片带凸台带槽) Crown diskette with boss and groove	
3	粘和剂 Binding agent	JS-E103 (加稠) 白胶 (thickened) white glue	
4			
5			
6			
7			