

承认书

客户名称 Customer name: _____

客户料号 Customer data: 苹果线圈

我司型号 Our model number: YD- G25-2.5-6.8UH-3200GS-50MM

送样日期 Sample delivery date: 2023 年 11月15 日

供应方 Supply side: 深圳市金天纬科技有限公司

绘制 Draw up	审核 Audit	批准 Permission granted

客户承认 Client acknowledges:

合格 Qualified	不合格 Disqualified	承认 Admit it
备注 Notes		

深圳市金天纬科技有限公司

Shenzhen Jintianwei Technology Co., Ltd

Tel: _____

Fax: _____

客户名称 Customer name	客户料号 Customer data	我司型号 Our model number	版本 Version	日期 Date
		YD- G25-2.5-6.8UH-3200GS-50MM	A0	2023.11.15

一、平面结构图：单位:MM Floor plan: unit: MM

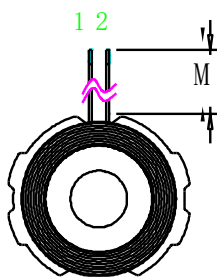
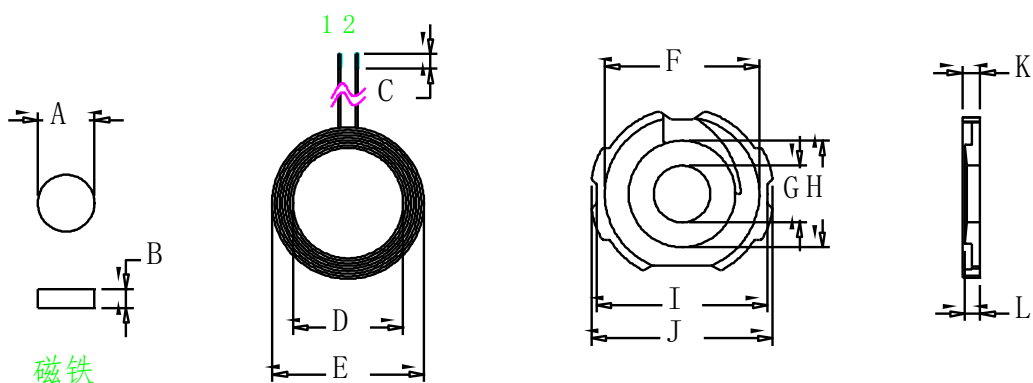

A	7.65 ± 0.05
B	2.5 ± 0.05
C	2 ± 1
D	15 ± 0.2
E	20.7 ± 0.3
F	21 ± 0.2
G	7.7 ± 0.05
H	14.5 ± 0.2
I	23.5 ± 0.3
J	25 ± 0.2
K	2.5 ± 0.1
L	2.25 ± 0.1
M	50 ± 2

二、产品参数 Product parameters:

脚位 Feet	线径 Line diameter	圈数 Number of turns	备注 Notes
1 - 2	0.08*24	13	热风绞合线 Hot Air Strand 材料温度: 105度

三、技术要求: Technical Requirements:

1. 把铜线的头和尾固定，防止铜线松或者断等现象。

Fix the head and tail of the copper wire to prevent loose or broken copper wire.

2. 按客户要求把多余的铜线的头部剪去，镀上锡，镀锡的深度为 1~3 mm ,浸锡温度为 450°.注意：焊接温度为 330°-360°!

According to customer requirements to cut the head of the excess copper wire, tinned, tinned depth of 1 ~ 3mm. The temperature of tin dipping is 450°.

Note: welding temperature is 330°-360°!

3. 在软的磁性片状物品上粘一些白胶，贴上铜线圈，在这过程中保证产品表面干净整洁。

Stick some white glue on the soft magnetic sheet and stick on the copper coil to ensure the clean and tidy surface of the product in the process.

4. 软的磁性片状物品上有圆孔，没有破损。

Soft magnetic flaky objects have round holes and are not damaged.

5. 附加工序（按客户要求）：在成品中间的圆孔装上 7.65x2.5mm 的磁铁，和在成品的背后再贴上直径为 14mm 的圆的双面胶，最后包装。

Additional process (according to customer requirements) : in the finished product in the middle of the round hole loaded with 7.65 x 2.5 mm magnet, and in the back of the finished product and then paste a diameter of 14 mm round double-sided adhesive, and finally packaging.

四、电性参数 Electrical parameter:

- 1.电感值，Q 值(带铁片): Inductance value, Q value(With a piece of iron)

$$PIN \quad 1 - 2 \quad = 6.8 \pm 5\%$$

$$Q \text{ 值} \geq 25$$

以上电感值以铨华 1062A 仪器，以 10KHZ/0.3Vrms 为标准或等同仪器。

Q 值以铨华 1062A 仪器，以 100KHZ/0.3Vrms 为标准或等同仪器

The above inductance values are based on chuanhua 1062A instrument, using 10KHZ/0.3 vrms as the standard or equivalent instrument. The Q value is based on chuanhua 1062A instrument and 100KHZ/0.3 vrms or equivalent instrument

五、材料清单 Bill of materials:

序号 NO	名称 Name	材质 Material Quality	供应商 Suppliers	备注 Notes
1	热风绞合线 Hot Air Strand	0.08X24	维汉或等同 Uyghur or equivalent	
2	磁片 Disk	G25 软基材 Soft substrate	天通或等同 TX or equivalent	带点
3	锡 Tin	高温环保 High temperature environmental protection	千岛或等同 Thond Island or equivalent	
4	白胶 White glue	BY882	宝月或等同 Treasure month or equivalent	
5	强磁 Strong magnetism	7.65*2.5 (强度 3200GS)	联胜或等同 Win-win or equal	