

124: Back of EUT Facing Phantom LTE FDD 17 10MHz 1RB Middle CH23780 Sensor Inactive

Date: 29/04/15

DUT: Inari 8; Type: Tablet

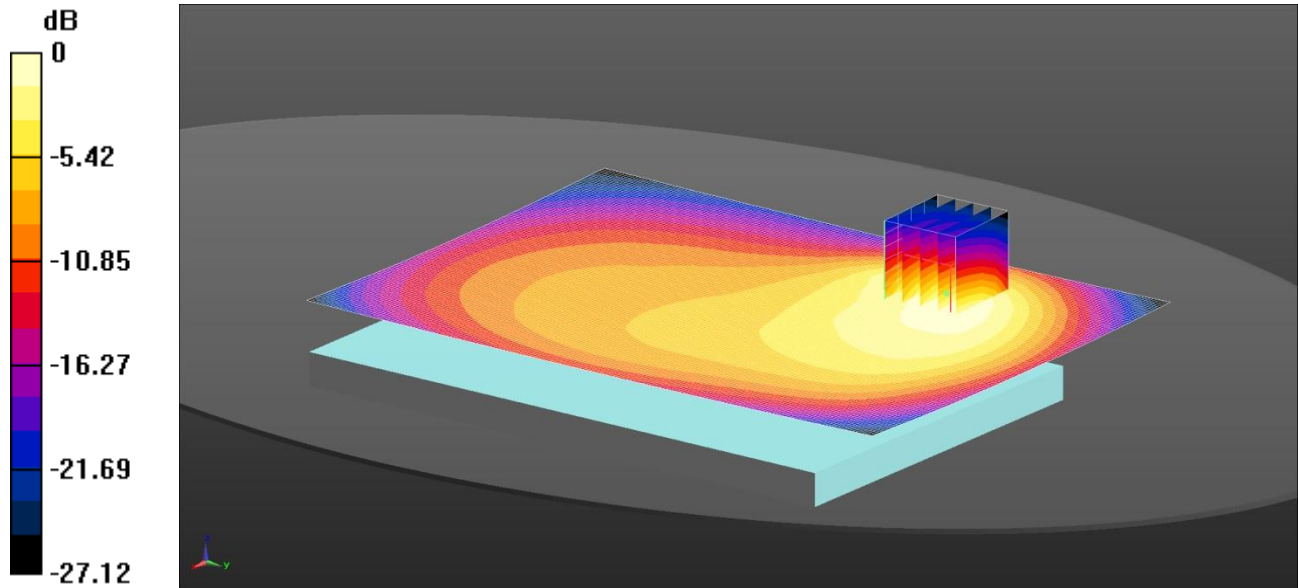

0 dB = 0.386 W/kg = -4.13 dBW/kg

Communication System: UID 0, LTE Bands - 10MHz Channel BW (0); Frequency: 709 MHz; Duty Cycle: 1:1
 Medium: 750 MHz HSL Medium parameters used (interpolated): $f = 709$ MHz; $\sigma = 0.904$ S/m; $\epsilon_r = 55.965$; $\rho = 1000$ kg/m³
 Phantom section: Flat Section
 DASY4 Configuration:
 - Probe: ES3DV3 - SN3341; ConvF(6.19, 6.19, 6.19); Calibrated: 21/08/14;
 - Sensor-Surface: 4mm (Mechanical Surface Detection)
 - Electronics: DAE4 Sn1435; Calibrated: 20/02/15
 - Phantom: ELI v5.0 (30deg probe tilt); Type: QDOVA002AA; Serial: TP:xxxx
 - ; SEMCAD X Version 14.6.10 (7331)

Configuration/Back - Low/Area Scan (121x171x1): Interpolated grid: dx=1.500 mm, dy=1.500 mm

Maximum value of SAR (interpolated) = 0.386 W/kg

Configuration/Back - Low/Zoom Scan (5x5x7) 2 2 (5x5x7)/Cube 0: Measurement grid: dx=8mm, dy=8mm, dz=5mm

Reference Value = 20.94 V/m; Power Drift = -0.04 dB

Peak SAR (extrapolated) = 0.518 W/kg

SAR(1 g) = 0.349 W/kg; SAR(10 g) = 0.231 W/kg

Maximum value of SAR (measured) = 0.382 W/kg

125: Back of EUT Facing Phantom LTE FDD 17 10MHz 1RB Middle CH23800 Sensor Inactive

Date: 29/04/15

DUT: Inari 8; Type: Tablet

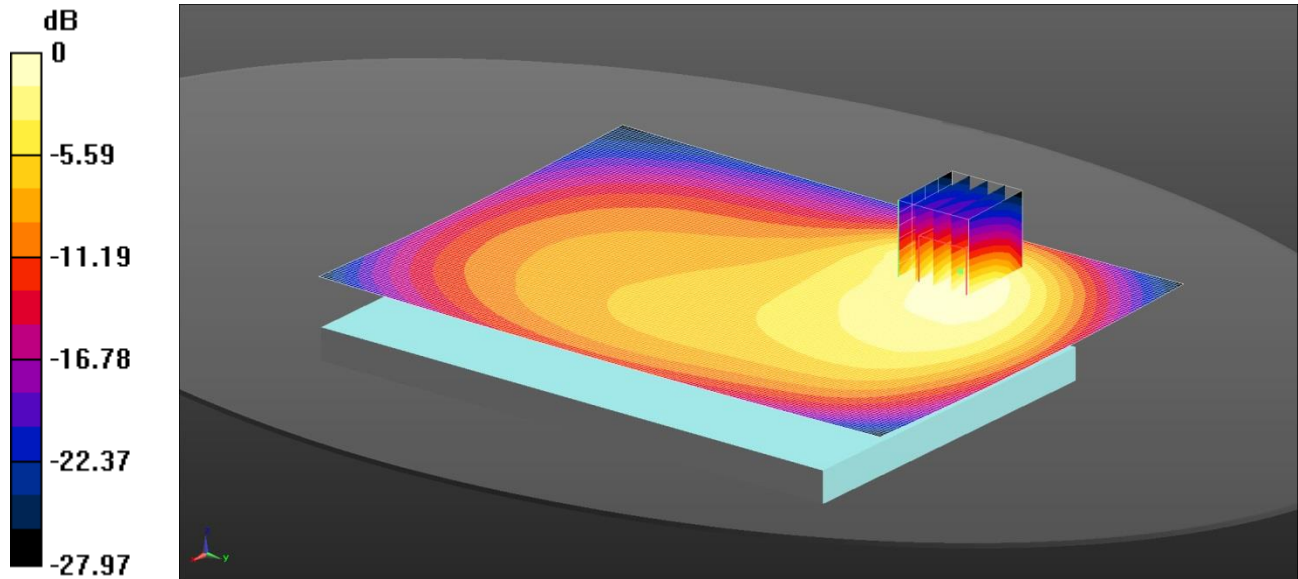

0 dB = 0.375 W/kg = -4.26 dBW/kg

Communication System: UID 0, LTE Bands - 10MHz Channel BW (0); Frequency: 711 MHz; Duty Cycle: 1:1
 Medium: 750 MHz HSL Medium parameters used (interpolated): $f = 711$ MHz; $\sigma = 0.905$ S/m; $\epsilon_r = 55.954$; $\rho = 1000$ kg/m³
 Phantom section: Flat Section
 DASY4 Configuration:
 - Probe: ES3DV3 - SN3341; ConvF(6.19, 6.19, 6.19); Calibrated: 21/08/14;
 - Sensor-Surface: 4mm (Mechanical Surface Detection)
 - Electronics: DAE4 Sn1435; Calibrated: 20/02/15
 - Phantom: ELI v5.0 (30deg probe tilt); Type: QDOVA002AA; Serial: TP:xxxx
 - ; SEMCAD X Version 14.6.10 (7331)

Configuration/Back - High/Area Scan (121x171x1): Interpolated grid: dx=1.500 mm, dy=1.500 mm

Maximum value of SAR (interpolated) = 0.375 W/kg

Configuration/Back - High/Zoom Scan (5x5x7) 2 2 (5x5x7)/Cube 0: Measurement grid: dx=8mm, dy=8mm, dz=5mm

Reference Value = 11.99 V/m; Power Drift = 0.00 dB

Peak SAR (extrapolated) = 0.499 W/kg

SAR(1 g) = 0.339 W/kg; SAR(10 g) = 0.227 W/kg

Maximum value of SAR (measured) = 0.371 W/kg

126: Back of EUT Facing Phantom LTE FDD 17 10MHz 1RB Middle CH23780 Sensor Active

Date: 28/04/15

DUT: Inari 8; Type: Tablet

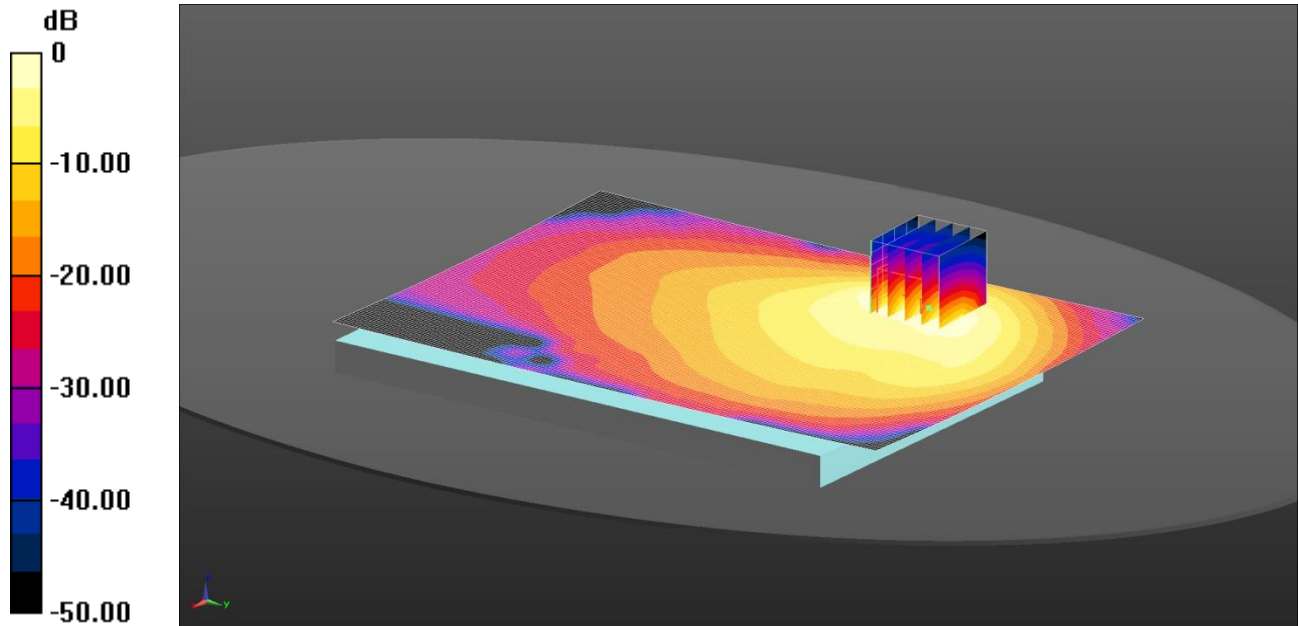

0 dB = 0.382 W/kg = -4.18 dBW/kg

Communication System: UID 0, LTE Bands - 10MHz Channel BW (0); Frequency: 709 MHz; Duty Cycle: 1:1
 Medium: 750 MHz HSL Medium parameters used (interpolated): $f = 709 \text{ MHz}$; $\sigma = 0.904 \text{ S/m}$; $\epsilon_r = 55.965$; $\rho = 1000 \text{ kg/m}^3$
 Phantom section: Flat Section
 DASY4 Configuration:
 - Probe: ES3DV3 - SN3341; ConvF(6.19, 6.19, 6.19); Calibrated: 21/08/14;
 - Sensor-Surface: 4mm (Mechanical Surface Detection)
 - Electronics: DAE4 Sn1435; Calibrated: 20/02/15
 - Phantom: ELI v5.0 (30deg probe tilt); Type: QDOVA002AA; Serial: TP:xxxx
 - ; SEMCAD X Version 14.6.10 (7331)

Configuration/Back - Middle/Area Scan (121x171x1): Interpolated grid: $dx=1.500 \text{ mm}$, $dy=1.500 \text{ mm}$

Maximum value of SAR (interpolated) = 0.382 W/kg

Configuration/Back - Middle/Zoom Scan (5x5x7) (5x5x7)/Cube 0: Measurement grid: $dx=8\text{mm}$, $dy=8\text{mm}$, $dz=5\text{mm}$

Reference Value = 22.29 V/m; Power Drift = -0.11 dB

Peak SAR (extrapolated) = 0.681 W/kg

SAR(1 g) = 0.370 W/kg; SAR(10 g) = 0.204 W/kg

Maximum value of SAR (measured) = 0.427 W/kg

127: Back of EUT Facing Phantom LTE FDD 17 10MHz 50%RB Middle CH23780 Sensor Active

Date: 28/04/15

DUT: Inari 8; Type: Tablet

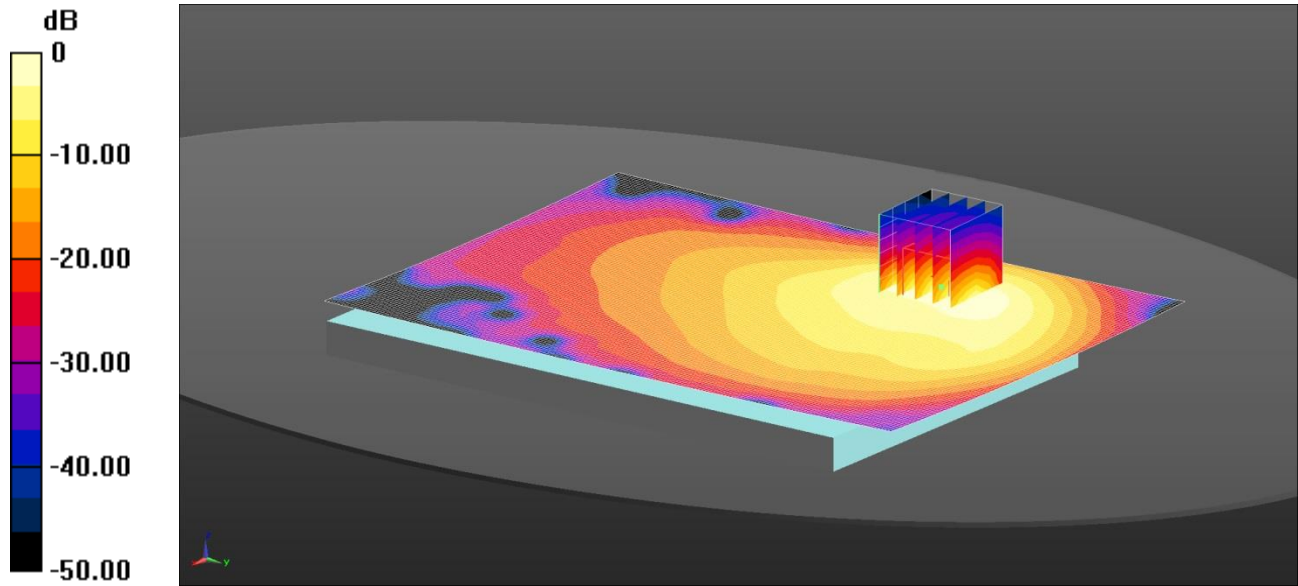

0 dB = 0.381 W/kg = -4.19 dBW/kg

Communication System: UID 0, LTE Bands - 10MHz Channel BW (0); Frequency: 709 MHz; Duty Cycle: 1:1
 Medium: 750 MHz HSL Medium parameters used (interpolated): $f = 709$ MHz; $\sigma = 0.904$ S/m; $\epsilon_r = 55.965$; $\rho = 1000$ kg/m³
 Phantom section: Flat Section

DASY4 Configuration:

- Probe: ES3DV3 - SN3341; ConvF(6.19, 6.19, 6.19); Calibrated: 21/08/14;
- Sensor-Surface: 4mm (Mechanical Surface Detection)
- Electronics: DAE4 Sn1435; Calibrated: 20/02/15
- Phantom: ELI v5.0 (30deg probe tilt); Type: QDOVA002AA; Serial: TP:xxxx
- ; SEMCAD X Version 14.6.10 (7331)

Configuration/Back - Middle/Area Scan (121x171x1): Interpolated grid: dx=1.500 mm, dy=1.500 mm

Maximum value of SAR (interpolated) = 0.381 W/kg

Configuration/Back - Middle/Zoom Scan (5x5x7) 2 2 (5x5x7)/Cube 0: Measurement grid: dx=8mm, dy=8mm, dz=5mm

Reference Value = 22.23 V/m; Power Drift = -0.02 dB

Peak SAR (extrapolated) = 0.675 W/kg

SAR(1 g) = 0.367 W/kg; SAR(10 g) = 0.203 W/kg

Maximum value of SAR (measured) = 0.425 W/kg

128: Top of EUT Facing Phantom LTE FDD 17 10MHz 1RB Middle CH23780 Sensor Active

Date: 28/04/15

DUT: Inari 8; Type: Tablet

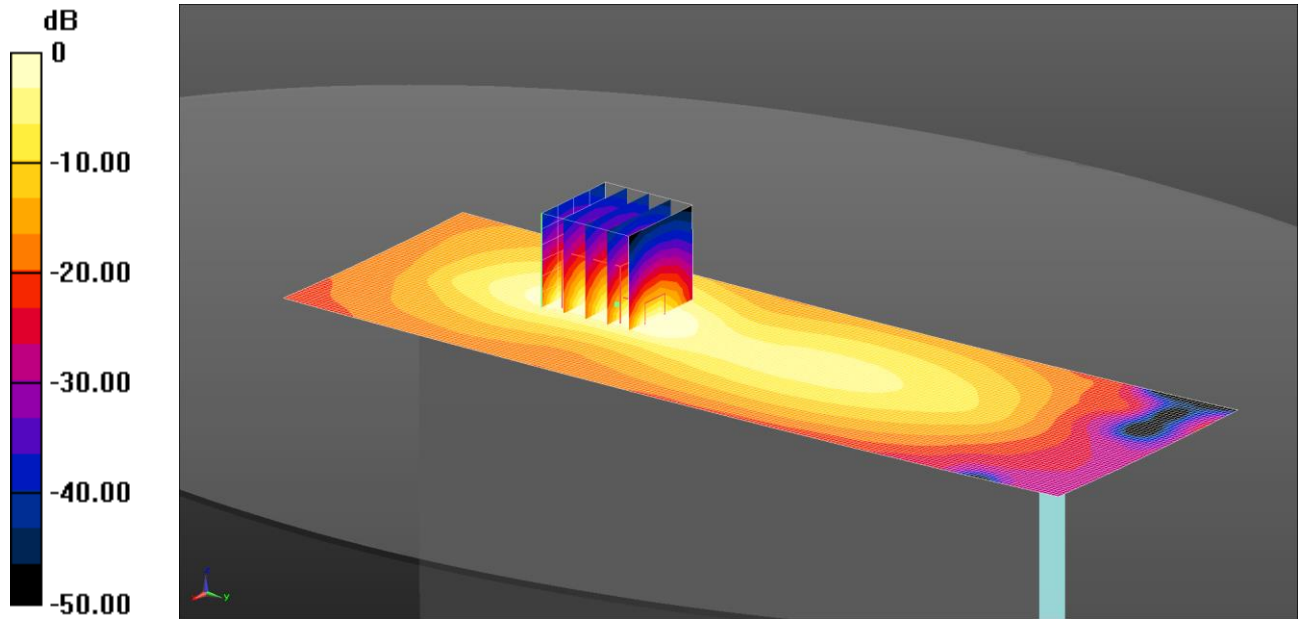

0 dB = 0.208 W/kg = -6.82 dBW/kg

Communication System: UID 0, LTE Bands - 10MHz Channel BW (0); Frequency: 709 MHz; Duty Cycle: 1:1
 Medium: 750 MHz HSL Medium parameters used (interpolated): f = 709 MHz; $\sigma = 0.904$ S/m; $\epsilon_r = 55.965$; $\rho = 1000$ kg/m³

Phantom section: Flat Section

DASY4 Configuration:

- Probe: ES3DV3 - SN3341; ConvF(6.19, 6.19, 6.19); Calibrated: 21/08/14;
- Sensor-Surface: 4mm (Mechanical Surface Detection)
- Electronics: DAE4 Sn1435; Calibrated: 20/02/15
- Phantom: ELI v5.0 (30deg probe tilt); Type: QDOVA002AA; Serial: TP:xxxx
- ; SEMCAD X Version 14.6.10 (7331)

Configuration/Top - Middle/Area Scan (61x191x1): Interpolated grid: dx=1.500 mm, dy=1.500 mm

Maximum value of SAR (interpolated) = 0.208 W/kg

Configuration/Top - Middle/Zoom Scan (5x5x7) 2 2 (5x5x7)/Cube 0: Measurement grid: dx=8mm, dy=8mm, dz=5mm

Reference Value = 15.76 V/m; Power Drift = 0.03 dB

Peak SAR (extrapolated) = 0.406 W/kg

SAR(1 g) = 0.187 W/kg; SAR(10 g) = 0.110 W/kg

Maximum value of SAR (measured) = 0.203 W/kg

129: Top of EUT Facing Phantom LTE FDD 17 10MHz 50%RB Middle CH23780 Sensor Active

Date: 28/04/15

DUT: Inari 8; Type: Tablet

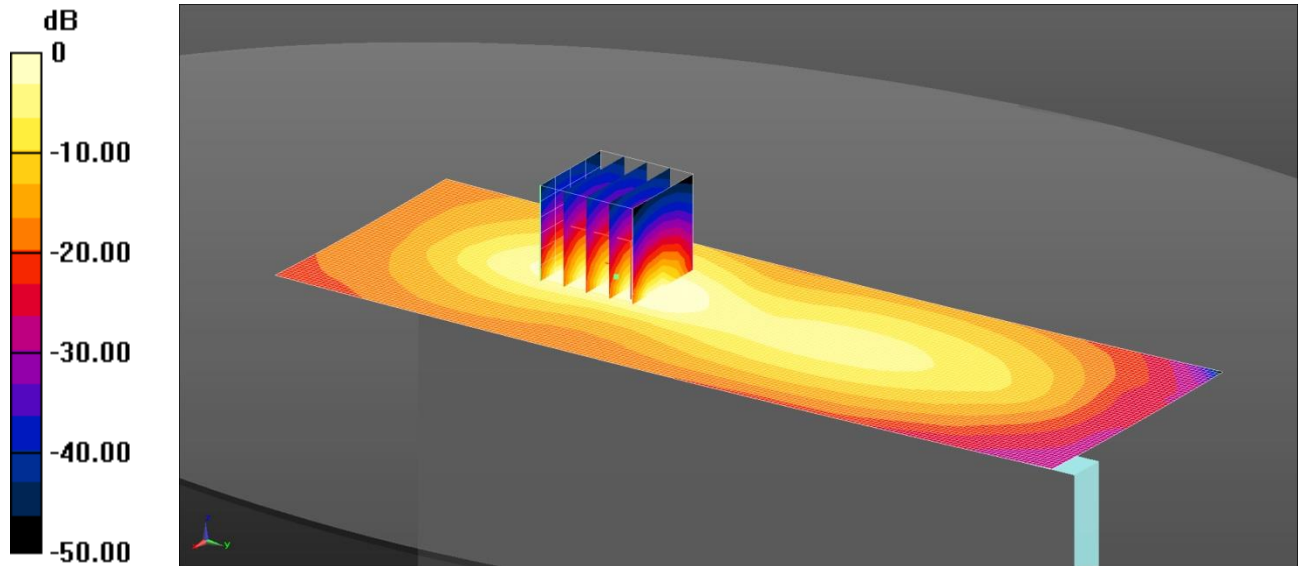

0 dB = 0.202 W/kg = -6.94 dBW/kg

Communication System: UID 0, LTE Bands - 10MHz Channel BW (0); Frequency: 709 MHz; Duty Cycle: 1:1

Medium: 750 MHz HSL Medium parameters used (interpolated): $f = 709 \text{ MHz}$; $\sigma = 0.904 \text{ S/m}$; $\epsilon_r = 55.965$; $\rho = 1000 \text{ kg/m}^3$

Phantom section: Flat Section

DASY4 Configuration:

- Probe: ES3DV3 - SN3341; ConvF(6.19, 6.19, 6.19); Calibrated: 21/08/14;
- Sensor-Surface: 4mm (Mechanical Surface Detection)
- Electronics: DAE4 Sn1435; Calibrated: 20/02/15
- Phantom: ELI v5.0 (30deg probe tilt); Type: QDOVA002AA; Serial: TP:xxxx
- ; SEMCAD X Version 14.6.10 (7331)

Configuration/Top - Middle/Area Scan (61x181x1): Interpolated grid: $dx=1.500 \text{ mm}$, $dy=1.500 \text{ mm}$

Maximum value of SAR (interpolated) = 0.202 W/kg

Configuration/Top - Middle/Zoom Scan (5x5x7) 2 2 (5x5x7)/Cube 0: Measurement grid: $dx=8\text{mm}$, $dy=8\text{mm}$, $dz=5\text{mm}$

Reference Value = 15.29 V/m; Power Drift = -0.07 dB

Peak SAR (extrapolated) = 0.364 W/kg

SAR(1 g) = 0.185 W/kg; SAR(10 g) = 0.109 W/kg

Maximum value of SAR (measured) = 0.204 W/kg

130: Back of EUT Facing Phantom LTE FDD 25 20MHz 1RB Low CH26365 Sensor Inactive

Date: 22/04/2015

DUT: Inari 8; Type: Tablet

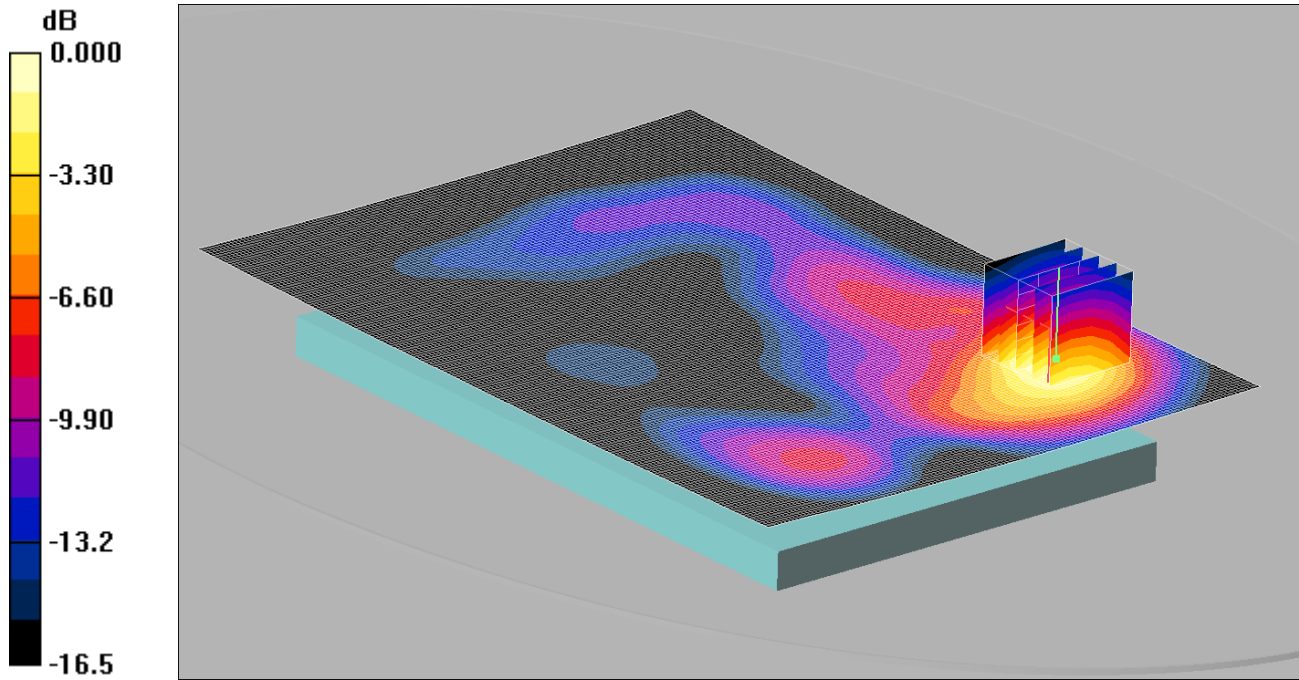

0 dB = 0.684mW/g

Communication System: LTE - Band 25 / 20MHz Channel; Frequency: 1882.5 MHz; Duty Cycle: 1:1
 Medium: 1900 MHz MSL Medium parameters used (interpolated): $f = 1882.5$ MHz; $\sigma = 1.51$ mho/m; $\epsilon_r = 52.2$; $\rho = 1000$ kg/m³

Phantom section: Flat Section

DASY4 Configuration:

- Probe: ES3DV3 - SN3304; ConvF(4.69, 4.69, 4.69);
- Sensor-Surface: 4mm (Mechanical Surface Detection)
- Electronics: DAE3 Sn432; Calibrated: 20/08/2014
- Phantom: ELI v5.0; Type: QDOVA002AA; Serial: TP:xxxx
- Measurement SW: DASY4, V4.7 Build 80; Postprocessing SW: SEMCAD, V1.8 Build 186

Back - Low/Area Scan (131x181x1): Measurement grid: dx=15mm, dy=15mm
 Maximum value of SAR (interpolated) = 0.702 mW/g

Back - Low/Zoom Scan (5x5x7) (5x5x7)/Cube 0: Measurement grid: dx=8mm, dy=8mm, dz=5mm
 Reference Value = 17.1 V/m; Power Drift = -0.030 dB
 Peak SAR (extrapolated) = 1.03 W/kg

SAR(1 g) = 0.624 mW/g; SAR(10 g) = 0.364 mW/g
 Maximum value of SAR (measured) = 0.684 mW/g

131: Back of EUT Facing Phantom LTE FDD 25 20MHz 50%RB Low CH26365 Sensor Inactive

Date: 22/04/2015

DUT: Inari 8; Type: Tablet

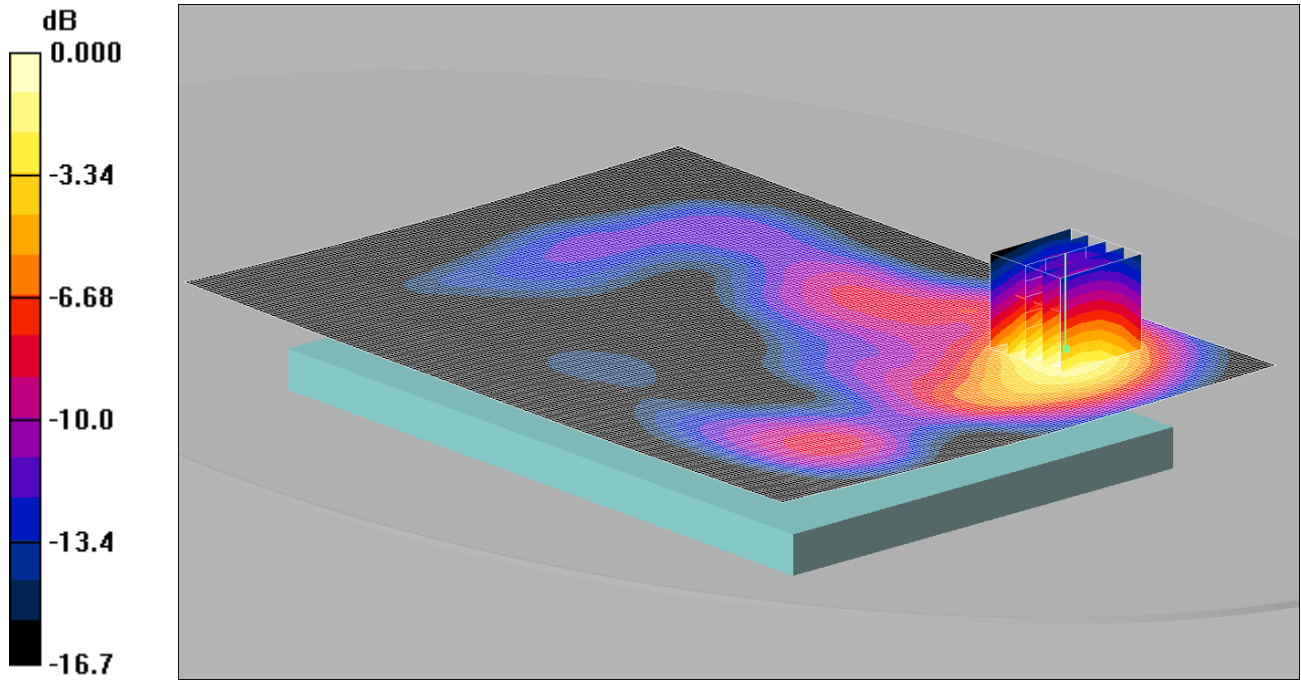

0 dB = 0.507mW/g

Communication System: LTE - Band 25 / 20MHz Channel; Frequency: 1882.5 MHz; Duty Cycle: 1:1
 Medium: 1900 MHz MSL Medium parameters used (interpolated): $f = 1882.5$ MHz; $\sigma = 1.51$ mho/m; $\epsilon_r = 52.2$; $\rho = 1000$ kg/m³

Phantom section: Flat Section

DASY4 Configuration:

- Probe: ES3DV3 - SN3304; ConvF(4.69, 4.69, 4.69);
- Sensor-Surface: 4mm (Mechanical Surface Detection)
- Electronics: DAE3 Sn432; Calibrated: 20/08/2014
- Phantom: ELI v5.0; Type: QDOVA002AA; Serial: TP:xxxx
- Measurement SW: DASY4, V4.7 Build 80; Postprocessing SW: SEMCAD, V1.8 Build 186

Back - Low/Area Scan (131x181x1): Measurement grid: dx=15mm, dy=15mm
 Maximum value of SAR (interpolated) = 0.524 mW/g

Back - Low/Zoom Scan (5x5x7) (5x5x7)/Cube 0: Measurement grid: dx=8mm, dy=8mm, dz=5mm
 Reference Value = 18.8 V/m; Power Drift = -0.007 dB
 Peak SAR (extrapolated) = 0.761 W/kg

SAR(1 g) = 0.462 mW/g; SAR(10 g) = 0.270 mW/g
 Maximum value of SAR (measured) = 0.507 mW/g

132: Top of EUT Facing Phantom LTE FDD 25 20MHz 1RB Low CH26365 Sensor Inactive

Date: 22/04/2015

DUT: Inari 8; Type: Tablet

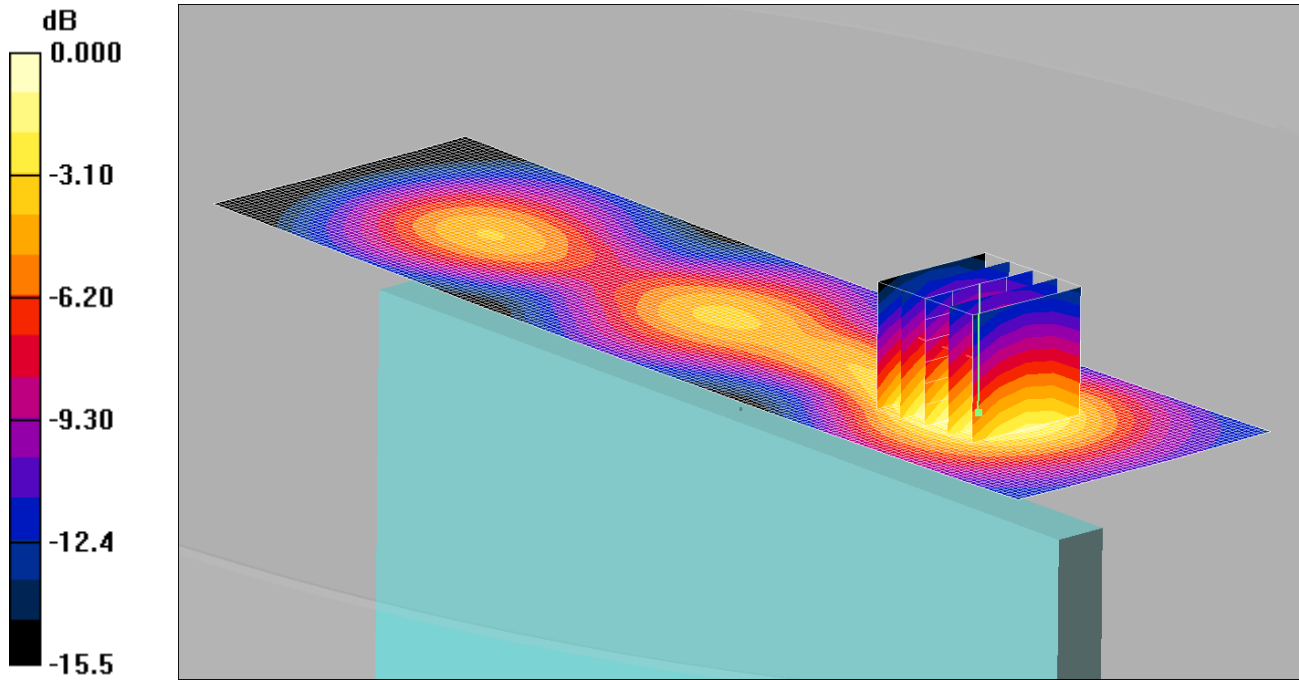

0 dB = 0.529mW/g

Communication System: LTE - Band 25 / 20MHz Channel; Frequency: 1882.5 MHz; Duty Cycle: 1:1
 Medium: 1900 MHz MSL Medium parameters used (interpolated): $f = 1882.5$ MHz; $\sigma = 1.51$ mho/m; $\epsilon_r = 52.2$; $\rho = 1000$ kg/m³

Phantom section: Flat Section

DASY4 Configuration:

- Probe: ES3DV3 - SN3304; ConvF(4.69, 4.69, 4.69);
- Sensor-Surface: 4mm (Mechanical Surface Detection)
- Electronics: DAE3 Sn432; Calibrated: 20/08/2014
- Phantom: ELI v5.0; Type: QDOVA002AA; Serial: TP:xxxx
- Measurement SW: DASY4, V4.7 Build 80; Postprocessing SW: SEMCAD, V1.8 Build 186

Top - Middle/Area Scan (51x181x1): Measurement grid: dx=15mm, dy=15mm
 Maximum value of SAR (interpolated) = 0.558 mW/g

Top - Middle/Zoom Scan (5x5x7) (5x5x7)/Cube 0: Measurement grid: dx=8mm, dy=8mm, dz=5mm
 Reference Value = 19.2 V/m; Power Drift = -0.014 dB
 Peak SAR (extrapolated) = 0.757 W/kg

SAR(1 g) = 0.489 mW/g; SAR(10 g) = 0.299 mW/g
 Maximum value of SAR (measured) = 0.529 mW/g

133: Top of EUT Facing Phantom LTE FDD 25 20MHz 50%RB Low CH26365 Sensor Inactive

Date: 22/04/2015

DUT: Inari 8; Type: Tablet

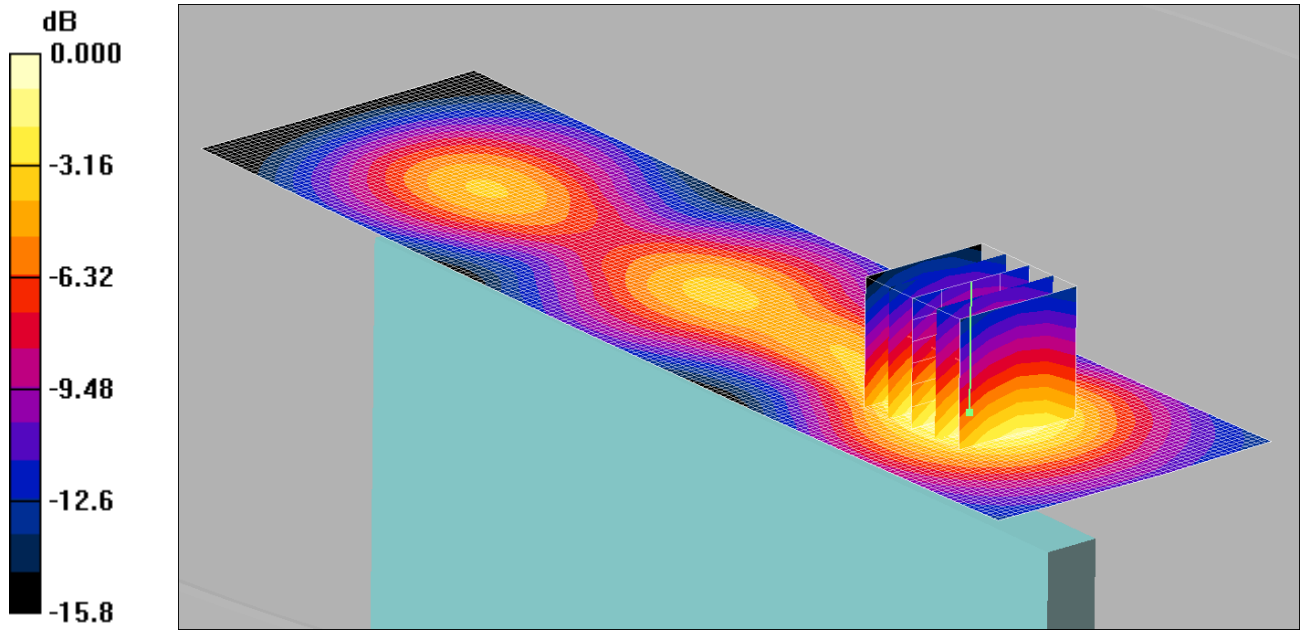

0 dB = 0.410mW/g

Communication System: LTE - Band 25 / 20MHz Channel; Frequency: 1882.5 MHz; Duty Cycle: 1:1

Medium: 1900 MHz MSL Medium parameters used (interpolated): $f = 1882.5$ MHz; $\sigma = 1.51$ mho/m; $\epsilon_r = 52.2$; $\rho = 1000$ kg/m³

Phantom section: Flat Section

DASY4 Configuration:

- Probe: ES3DV3 - SN3304; ConvF(4.69, 4.69, 4.69);
- Sensor-Surface: 4mm (Mechanical Surface Detection)
- Electronics: DAE3 Sn432; Calibrated: 20/08/2014
- Phantom: ELI v5.0; Type: QDOVA002AA; Serial: TP:xxxx
- Measurement SW: DASY4, V4.7 Build 80; Postprocessing SW: SEMCAD, V1.8 Build 186

Top - Middle/Area Scan (51x181x1): Measurement grid: dx=15mm, dy=15mm

Maximum value of SAR (interpolated) = 0.424 mW/g

Top - Middle/Zoom Scan (5x5x7) (5x5x7)/Cube 0: Measurement grid: dx=8mm, dy=8mm, dz=5mm

Reference Value = 16.7 V/m; Power Drift = 0.092 dB

Peak SAR (extrapolated) = 0.580 W/kg

SAR(1 g) = 0.375 mW/g; SAR(10 g) = 0.228 mW/g

Maximum value of SAR (measured) = 0.410 mW/g

134: Left of EUT Facing Phantom LTE FDD 25 20MHz 1RB Low CH26365 Sensor Inactive

Date: 22/04/2015

DUT: Inari 8; Type: Tablet

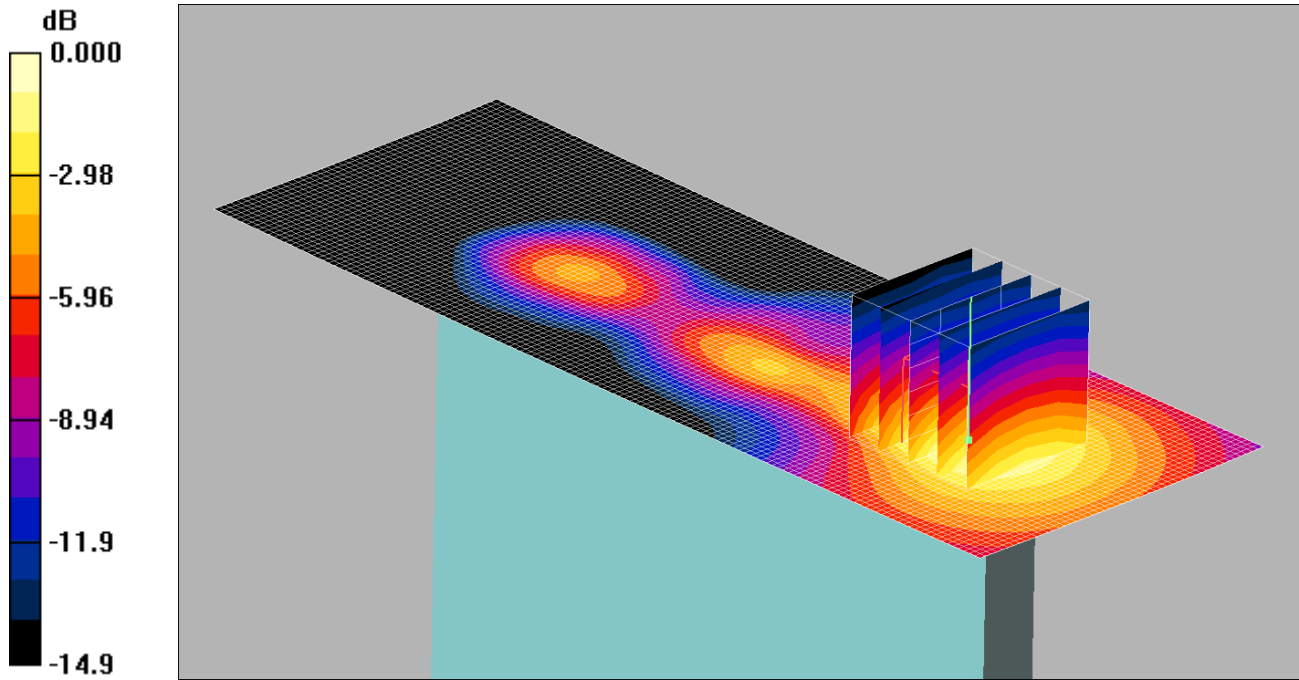

0 dB = 0.281mW/g

Communication System: LTE - Band 25 / 20MHz Channel; Frequency: 1882.5 MHz; Duty Cycle: 1:1
 Medium: 1900 MHz MSL Medium parameters used (interpolated): $f = 1882.5$ MHz; $\sigma = 1.51$ mho/m; $\epsilon_r = 52.2$; $\rho = 1000$ kg/m³

Phantom section: Flat Section

DASY4 Configuration:

- Probe: ES3DV3 - SN3304; ConvF(4.69, 4.69, 4.69);
- Sensor-Surface: 4mm (Mechanical Surface Detection)
- Electronics: DAE3 Sn432; Calibrated: 20/08/2014
- Phantom: ELI v5.0; Type: QDOVA002AA; Serial: TP:xxxx
- Measurement SW: DASY4, V4.7 Build 80; Postprocessing SW: SEMCAD, V1.8 Build 186

Left - Middle/Area Scan (51x141x1): Measurement grid: dx=15mm, dy=15mm
 Maximum value of SAR (interpolated) = 0.270 mW/g

Left - Middle/Zoom Scan (5x5x7) (5x5x7)/Cube 0: Measurement grid: dx=8mm, dy=8mm, dz=5mm
 Reference Value = 13.9 V/m; Power Drift = -0.001 dB
 Peak SAR (extrapolated) = 0.436 W/kg
SAR(1 g) = 0.252 mW/g; SAR(10 g) = 0.146 mW/g
 Maximum value of SAR (measured) = 0.281 mW/g

135: Left of EUT Facing Phantom LTE FDD 25 20MHz 50%RB Low CH26365 Sensor Inactive

Date: 22/04/2015

DUT: Inari 8; Type: Tablet

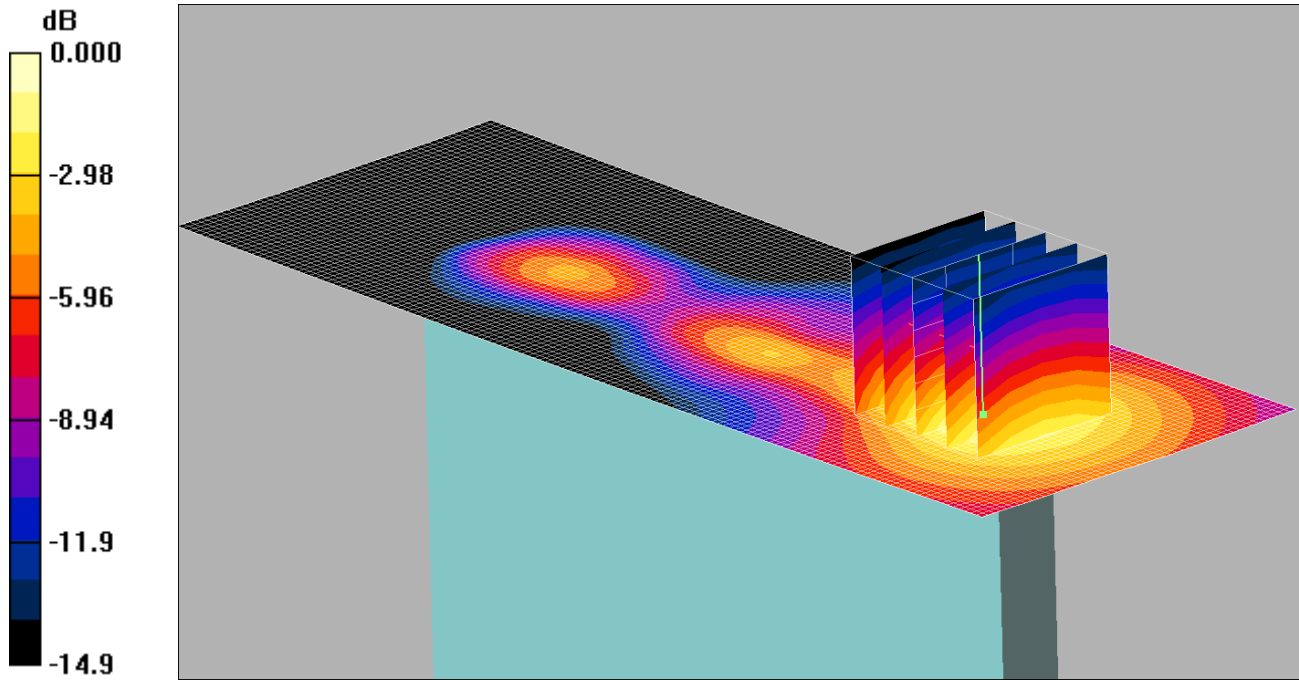

0 dB = 0.207mW/g

Communication System: LTE - Band 25 / 20MHz Channel; Frequency: 1882.5 MHz; Duty Cycle: 1:1
 Medium: 1900 MHz MSL Medium parameters used (interpolated): $f = 1882.5$ MHz; $\sigma = 1.51$ mho/m; $\epsilon_r = 52.2$; $\rho = 1000$ kg/m³

Phantom section: Flat Section

DASY4 Configuration:

- Probe: ES3DV3 - SN3304; ConvF(4.69, 4.69, 4.69);
- Sensor-Surface: 4mm (Mechanical Surface Detection)
- Electronics: DAE3 Sn432; Calibrated: 20/08/2014
- Phantom: ELI v5.0; Type: QDOVA002AA; Serial: TP:xxxx
- Measurement SW: DASY4, V4.7 Build 80; Postprocessing SW: SEMCAD, V1.8 Build 186

Left - Middle/Area Scan (51x141x1): Measurement grid: dx=15mm, dy=15mm
 Maximum value of SAR (interpolated) = 0.195 mW/g

Left - Middle/Zoom Scan (5x5x7) (5x5x7)/Cube 0: Measurement grid: dx=8mm, dy=8mm, dz=5mm
 Reference Value = 12.0 V/m; Power Drift = 0.021 dB
 Peak SAR (extrapolated) = 0.324 W/kg

SAR(1 g) = 0.186 mW/g; SAR(10 g) = 0.106 mW/g
 Maximum value of SAR (measured) = 0.207 mW/g

136: Back of EUT Facing Phantom LTE FDD 25 20MHz 1RB High CH26365 Sensor Inactive

Date: 22/04/2015

DUT: Inari 8; Type: Tablet

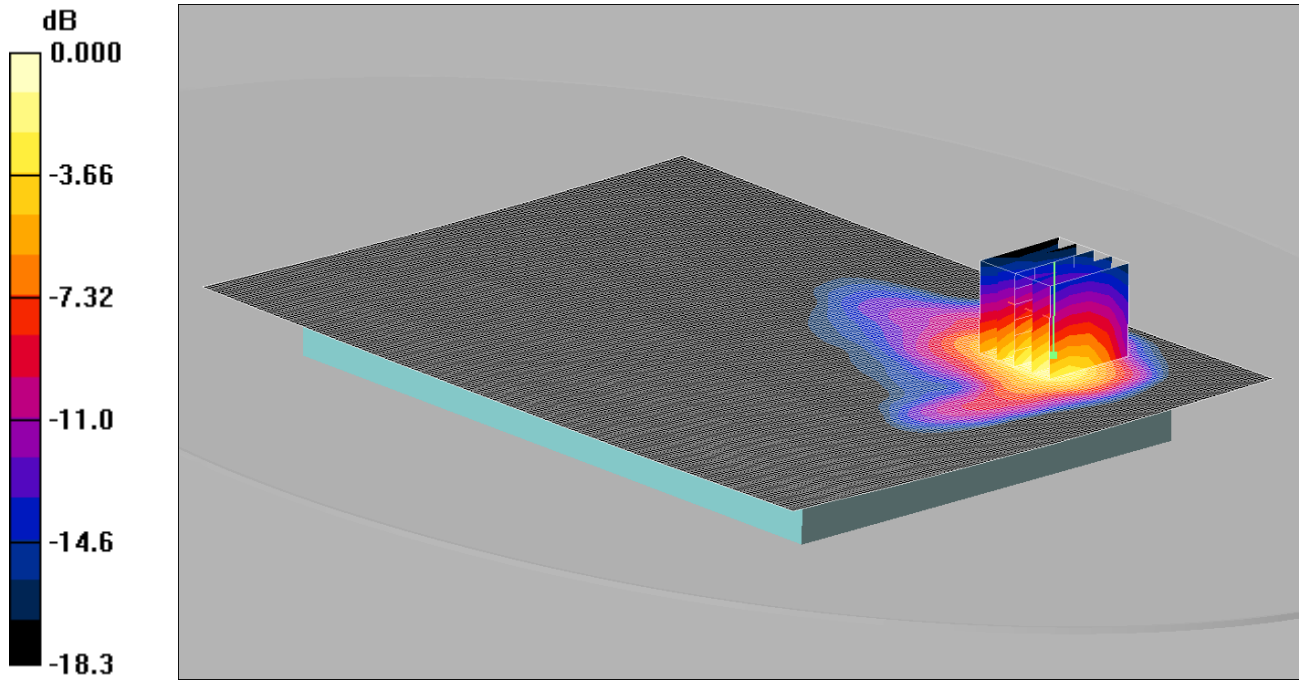

0 dB = 0.627mW/g

Communication System: LTE - Band 25 / 20MHz Channel; Frequency: 1882.5 MHz; Duty Cycle: 1:1
 Medium: 1900 MHz MSL Medium parameters used (interpolated): $f = 1882.5$ MHz; $\sigma = 1.51$ mho/m; $\epsilon_r = 52.2$; $\rho = 1000$ kg/m³

Phantom section: Flat Section

DASY4 Configuration:

- Probe: ES3DV3 - SN3304; ConvF(4.69, 4.69, 4.69);
- Sensor-Surface: 4mm (Mechanical Surface Detection)
- Electronics: DAE3 Sn432; Calibrated: 20/08/2014
- Phantom: ELI v5.0; Type: QDOVA002AA; Serial: TP:xxxx
- Measurement SW: DASY4, V4.7 Build 80; Postprocessing SW: SEMCAD, V1.8 Build 186

Back - Middle/Area Scan (131x181x1): Measurement grid: dx=15mm, dy=15mm

Maximum value of SAR (interpolated) = 0.733 mW/g

Back - Middle/Zoom Scan (5x5x7) (5x5x7)/Cube 0: Measurement grid: dx=8mm, dy=8mm, dz=5mm

Reference Value = 14.5 V/m; Power Drift = 0.067 dB

Peak SAR (extrapolated) = 1.20 W/kg

SAR(1 g) = 0.577 mW/g; SAR(10 g) = 0.291 mW/g

Maximum value of SAR (measured) = 0.627 mW/g

137: Back of EUT Facing Phantom LTE FDD 25 20MHz 50%RB High CH26365 Sensor Active

Date: 22/04/2015

DUT: Inari 8; Type: Tablet

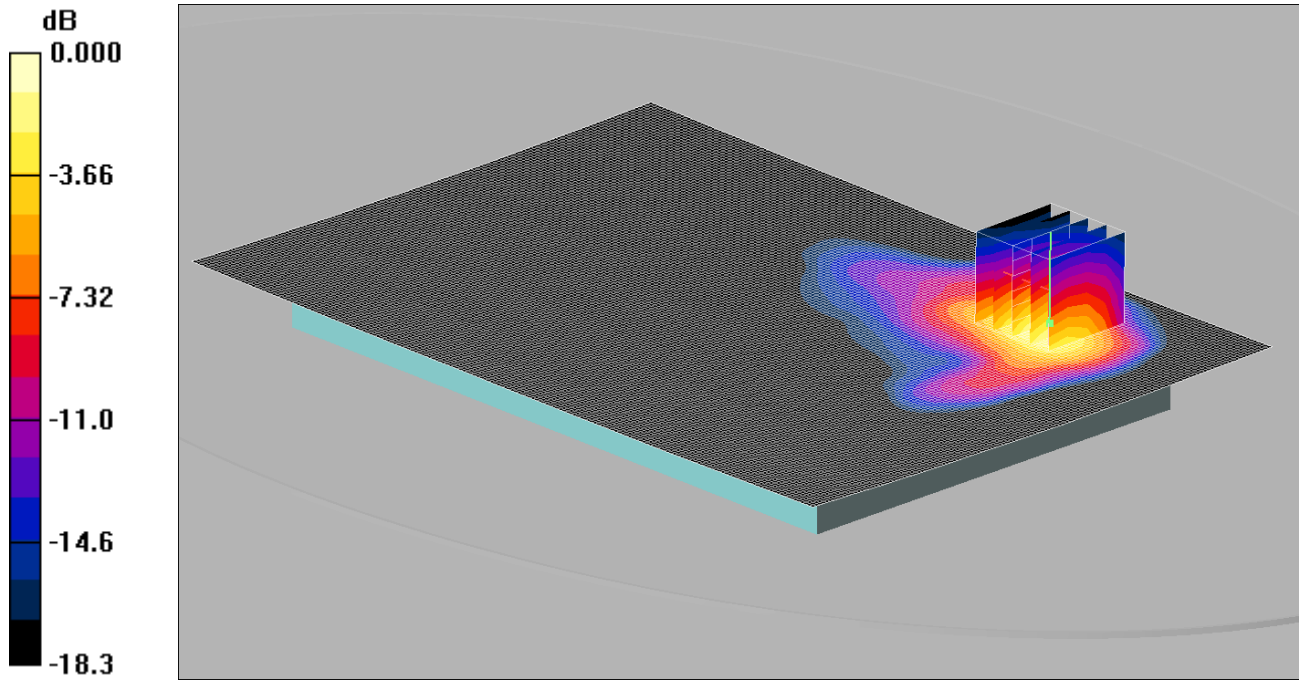

0 dB = 0.562mW/g

Communication System: LTE - Band 25 / 20MHz Channel; Frequency: 1882.5 MHz; Duty Cycle: 1:1

Medium: 1900 MHz MSL Medium parameters used (interpolated): $f = 1882.5$ MHz; $\sigma = 1.51$ mho/m; $\epsilon_r = 52.2$; $\rho = 1000$ kg/m³

Phantom section: Flat Section

DASY4 Configuration:

- Probe: ES3DV3 - SN3304; ConvF(4.69, 4.69, 4.69);
- Sensor-Surface: 4mm (Mechanical Surface Detection)
- Electronics: DAE3 Sn432; Calibrated: 20/08/2014
- Phantom: ELI v5.0; Type: QDOVA002AA; Serial: TP:xxxx
- Measurement SW: DASY4, V4.7 Build 80; Postprocessing SW: SEMCAD, V1.8 Build 186

Back - Middle/Area Scan (131x181x1): Measurement grid: dx=15mm, dy=15mm

Maximum value of SAR (interpolated) = 0.656 mW/g

Back - Middle/Zoom Scan (5x5x7) (5x5x7)/Cube 0: Measurement grid: dx=8mm, dy=8mm, dz=5mm

Reference Value = 19.9 V/m; Power Drift = 0.024 dB

Peak SAR (extrapolated) = 1.07 W/kg

SAR(1 g) = 0.516 mW/g; SAR(10 g) = 0.261 mW/g

Maximum value of SAR (measured) = 0.562 mW/g

138: Top of EUT Facing Phantom LTE FDD 25 20MHz 1RB High CH26365 Sensor Active

Date: 22/04/2015

DUT: Inari 8; Type: Tablet

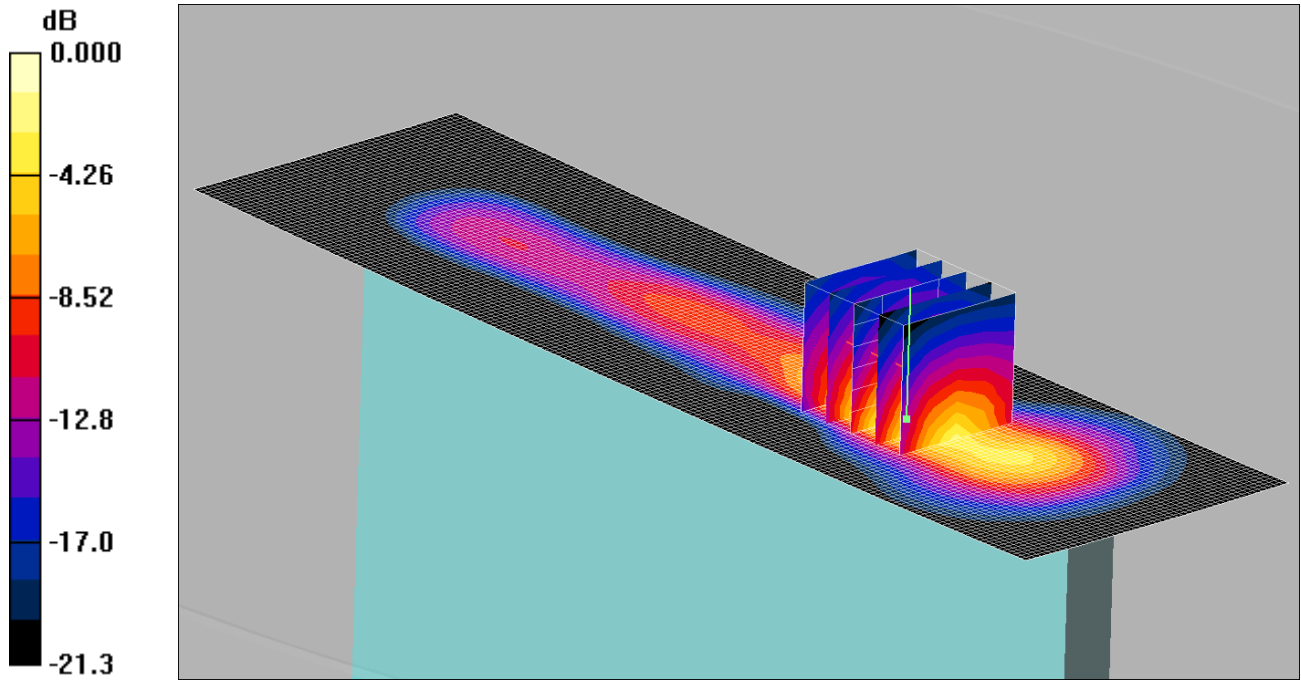

0 dB = 1.04mW/g

Communication System: LTE - Band 25 / 20MHz Channel; Frequency: 1882.5 MHz; Duty Cycle: 1:1
 Medium: 1900 MHz MSL Medium parameters used (interpolated): $f = 1882.5$ MHz; $\sigma = 1.51$ mho/m; $\epsilon_r = 52.2$; $\rho = 1000$ kg/m³

Phantom section: Flat Section

DASY4 Configuration:

- Probe: ES3DV3 - SN3304; ConvF(4.69, 4.69, 4.69);
- Sensor-Surface: 4mm (Mechanical Surface Detection)
- Electronics: DAE3 Sn432; Calibrated: 20/08/2014
- Phantom: ELI v5.0; Type: QDOVA002AA; Serial: TP:xxxx
- Measurement SW: DASY4, V4.7 Build 80; Postprocessing SW: SEMCAD, V1.8 Build 186

Top - Middle/Area Scan (51x181x1): Measurement grid: dx=15mm, dy=15mm
 Maximum value of SAR (interpolated) = 0.920 mW/g

Top - Middle/Zoom Scan (5x5x7) (5x5x7)/Cube 0: Measurement grid: dx=8mm, dy=8mm, dz=5mm
 Reference Value = 26.5 V/m; Power Drift = -0.038 dB
 Peak SAR (extrapolated) = 2.05 W/kg

SAR(1 g) = 0.894 mW/g; SAR(10 g) = 0.373 mW/g
 Maximum value of SAR (measured) = 1.04 mW/g

139: Top of EUT Facing Phantom LTE FDD 25 20MHz 1RB High CH26140 Sensor Active

Date: 23/04/2015

DUT: Inari 8; Type: Tablet

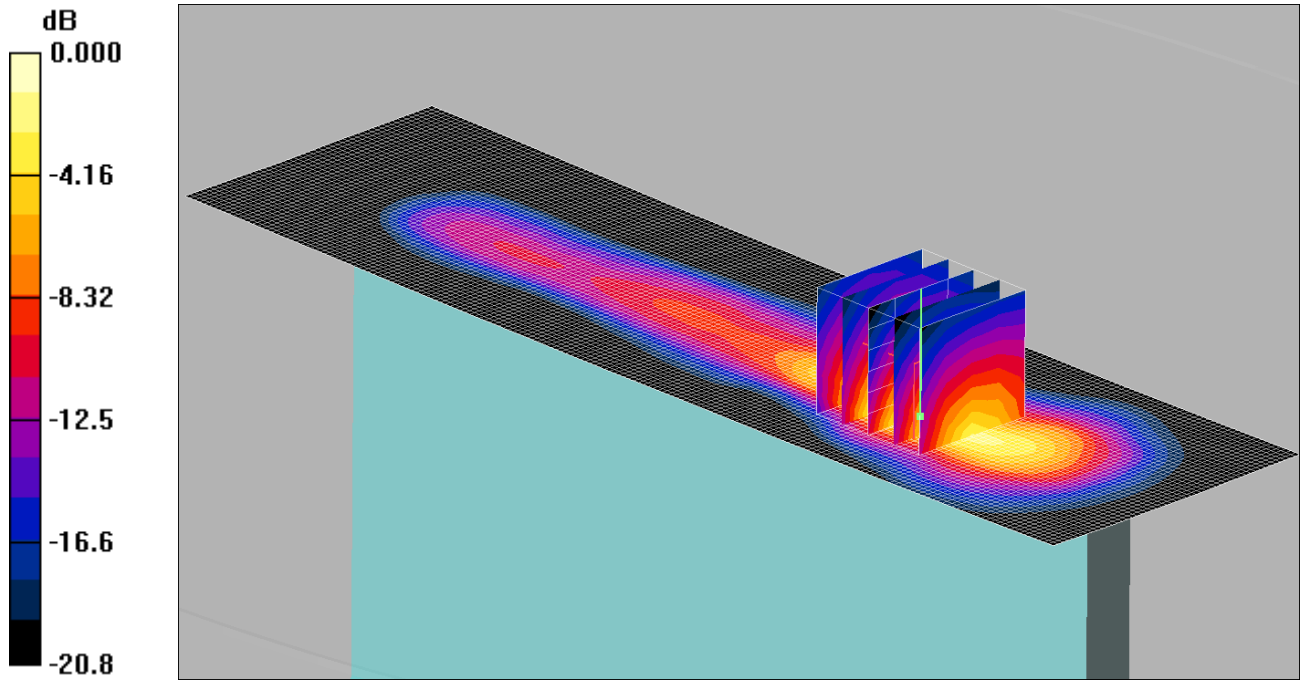

0 dB = 0.496mW/g

Communication System: LTE - Band 25 / 20MHz Channel; Frequency: 1860 MHz; Duty Cycle: 1:1
 Medium: 1900 MHz MSL Medium parameters used (interpolated): $f = 1860$ MHz; $\sigma = 1.48$ mho/m; $\epsilon_r = 52.7$; $\rho = 1000$ kg/m³

Phantom section: Flat Section

DASY4 Configuration:

- Probe: ES3DV3 - SN3304; ConvF(4.69, 4.69, 4.69);
- Sensor-Surface: 4mm (Mechanical Surface Detection)
- Electronics: DAE3 Sn432; Calibrated: 20/08/2014
- Phantom: ELI v5.0; Type: QDOVA002AA; Serial: TP:xxxx
- Measurement SW: DASY4, V4.7 Build 80; Postprocessing SW: SEMCAD, V1.8 Build 186

Top - Middle/Area Scan (51x181x1): Measurement grid: dx=15mm, dy=15mm
 Maximum value of SAR (interpolated) = 0.474 mW/g

Top - Middle/Zoom Scan (5x5x7) (5x5x7)/Cube 0: Measurement grid: dx=8mm, dy=8mm, dz=5mm

Reference Value = 17.5 V/m; Power Drift = -0.078 dB

Peak SAR (extrapolated) = 1.07 W/kg

SAR(1 g) = 0.452 mW/g; SAR(10 g) = 0.188 mW/g

Maximum value of SAR (measured) = 0.496 mW/g

140: Top of EUT Facing Phantom LTE FDD 25 20MHz 1RB High CH26590 Sensor Active

Date: 23/04/2015

DUT: Inari 8; Type: Tablet

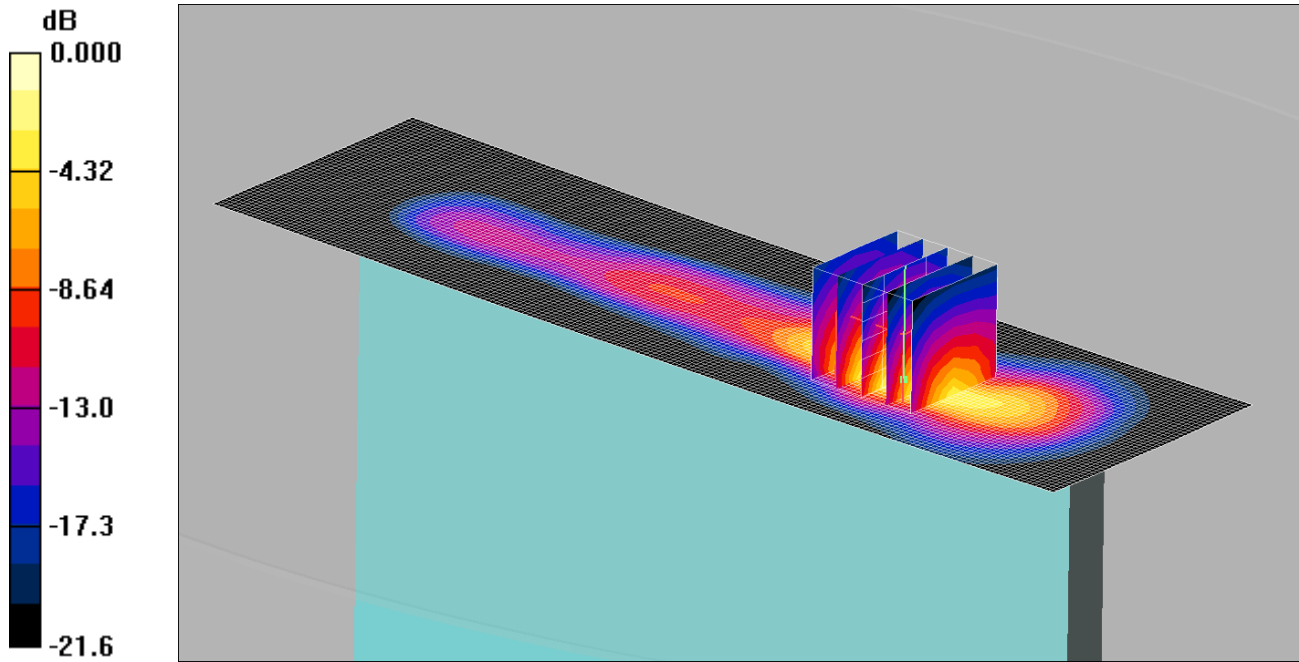

0 dB = 1.19mW/g

Communication System: LTE - Band 25 / 20MHz Channel; Frequency: 1905 MHz; Duty Cycle: 1:1

Medium: 1900 MHz MSL Medium parameters used (interpolated): $f = 1905 \text{ MHz}$; $\sigma = 1.52 \text{ mho/m}$; $\epsilon_r = 52.6$; $\rho = 1000 \text{ kg/m}^3$

Phantom section: Flat Section

DASY4 Configuration:

- Probe: ES3DV3 - SN3304; ConvF(4.69, 4.69, 4.69);
- Sensor-Surface: 4mm (Mechanical Surface Detection)
- Electronics: DAE3 Sn432; Calibrated: 20/08/2014
- Phantom: ELI v5.0; Type: QDOVA002AA; Serial: TP:xxxx
- Measurement SW: DASY4, V4.7 Build 80; Postprocessing SW: SEMCAD, V1.8 Build 186

Top - High/Area Scan (51x181x1): Measurement grid: $dx=15\text{mm}$, $dy=15\text{mm}$

Maximum value of SAR (interpolated) = 1.12 mW/g

Top - High/Zoom Scan (5x5x7) (5x5x7)/Cube 0: Measurement grid: $dx=8\text{mm}$, $dy=8\text{mm}$, $dz=5\text{mm}$

Reference Value = 28.6 V/m; Power Drift = 0.024 dB

Peak SAR (extrapolated) = 2.50 W/kg

SAR(1 g) = 1.06 mW/g; SAR(10 g) = 0.439 mW/g

Maximum value of SAR (measured) = 1.19 mW/g

141: Top of EUT Facing Phantom LTE FDD 25 20MHz 50%RB High CH26365 Sensor Active

Date: 23/04/2015

DUT: Inari 8; Type: Tablet

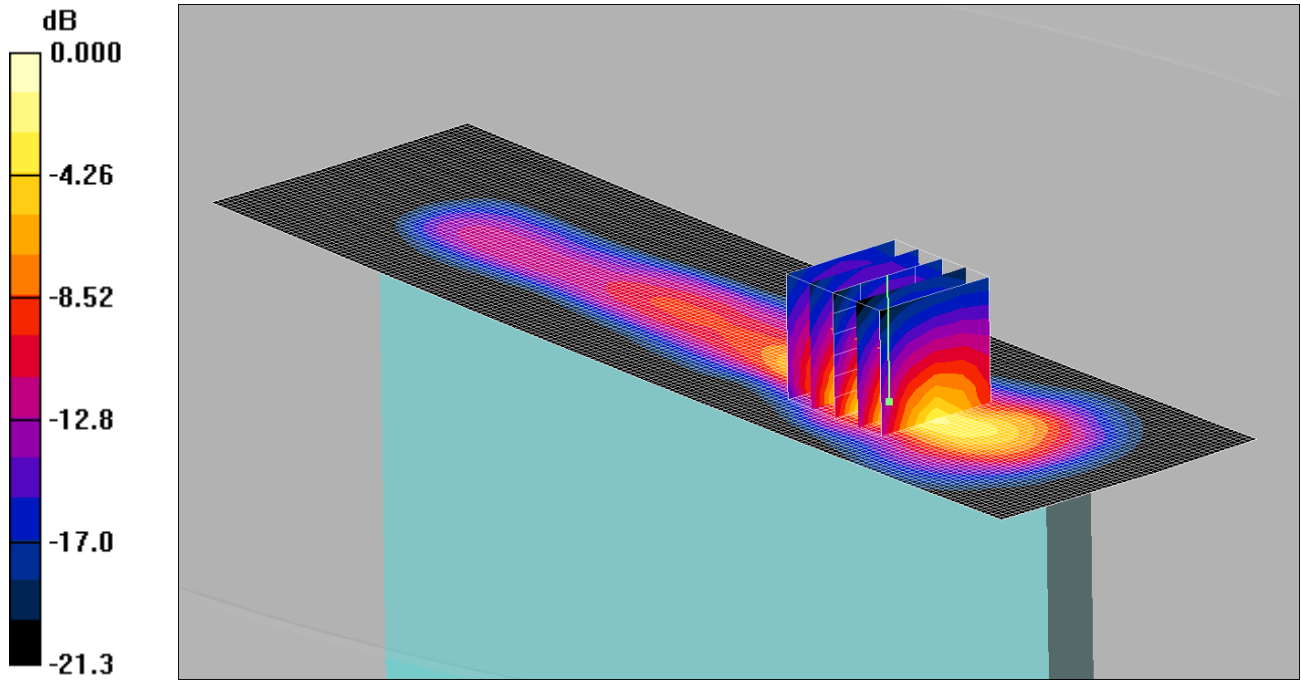

0 dB = 0.819mW/g

Communication System: LTE - Band 25 / 20MHz Channel; Frequency: 1882.5 MHz; Duty Cycle: 1:1
 Medium: 1900 MHz MSL Medium parameters used (interpolated): $f = 1882.5$ MHz; $\sigma = 1.5$ mho/m; $\epsilon_r = 52.6$; $\rho = 1000$ kg/m³

Phantom section: Flat Section

DASY4 Configuration:

- Probe: ES3DV3 - SN3304; ConvF(4.69, 4.69, 4.69);
- Sensor-Surface: 4mm (Mechanical Surface Detection)
- Electronics: DAE3 Sn432; Calibrated: 20/08/2014
- Phantom: ELI v5.0; Type: QDOVA002AA; Serial: TP:xxxx
- Measurement SW: DASY4, V4.7 Build 80; Postprocessing SW: SEMCAD, V1.8 Build 186

Top - Middle/Area Scan (51x181x1): Measurement grid: dx=15mm, dy=15mm
 Maximum value of SAR (interpolated) = 0.770 mW/g

Top - Middle/Zoom Scan (5x5x7) (5x5x7)/Cube 0: Measurement grid: dx=8mm, dy=8mm, dz=5mm

Reference Value = 23.9 V/m; Power Drift = -0.004 dB

Peak SAR (extrapolated) = 1.73 W/kg

SAR(1 g) = 0.731 mW/g; SAR(10 g) = 0.302 mW/g

Maximum value of SAR (measured) = 0.819 mW/g

142: Top of EUT Facing Phantom LTE FDD 25 20MHz 50%RB High CH26140 Sensor Active

Date: 23/04/2015

DUT: Inari 8; Type: Tablet

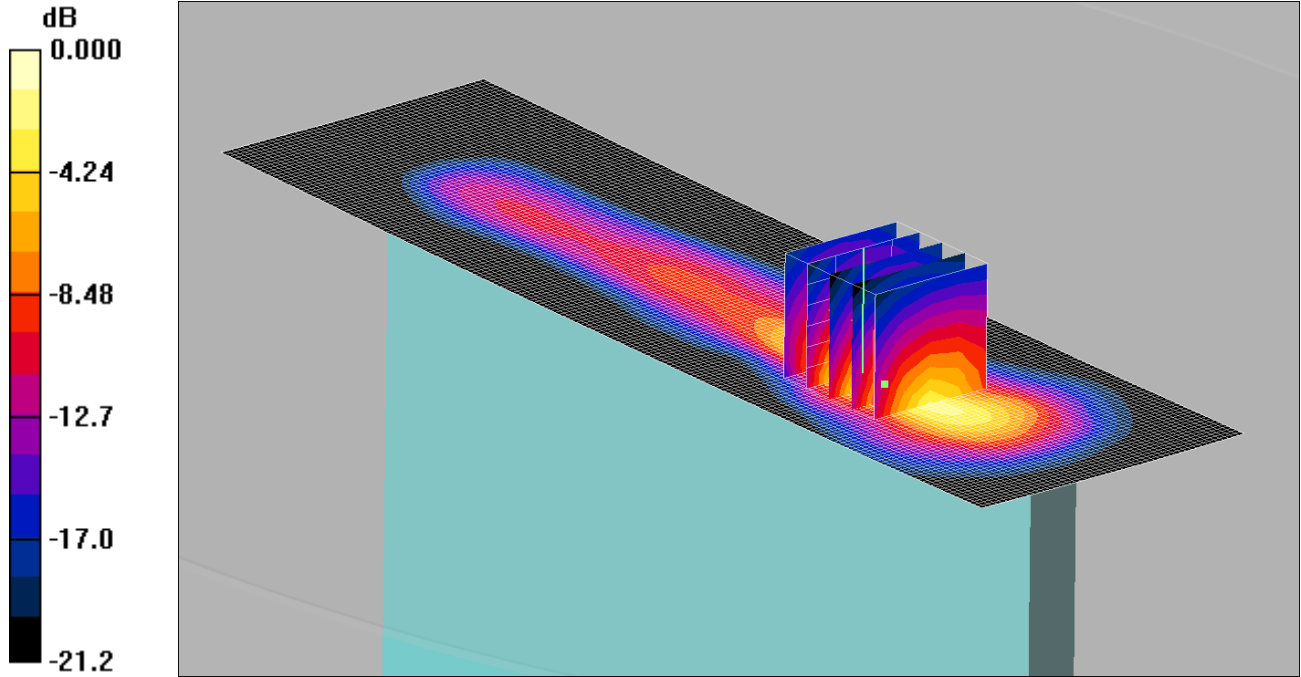

0 dB = 0.728mW/g

Communication System: LTE - Band 25 / 20MHz Channel; Frequency: 1860 MHz; Duty Cycle: 1:1
 Medium: 1900 MHz MSL Medium parameters used (interpolated): $f = 1860$ MHz; $\sigma = 1.48$ mho/m; $\epsilon_r = 52.7$; $\rho = 1000$ kg/m³
 Phantom section: Flat Section

DASY4 Configuration:

- Probe: ES3DV3 - SN3304; ConvF(4.69, 4.69, 4.69);
- Sensor-Surface: 4mm (Mechanical Surface Detection)
- Electronics: DAE3 Sn432; Calibrated: 20/08/2014
- Phantom: ELI v5.0; Type: QDOVA002AA; Serial: TP:xxxx
- Measurement SW: DASY4, V4.7 Build 80; Postprocessing SW: SEMCAD, V1.8 Build 186

Top - Low/Area Scan (51x181x1): Measurement grid: dx=15mm, dy=15mm
 Maximum value of SAR (interpolated) = 0.683 mW/g

Top - Low/Zoom Scan (5x5x7) (5x5x7)/Cube 0: Measurement grid: dx=8mm, dy=8mm, dz=5mm
 Reference Value = 22.6 V/m; Power Drift = -0.001 dB
 Peak SAR (extrapolated) = 1.57 W/kg
SAR(1 g) = 0.655 mW/g; SAR(10 g) = 0.270 mW/g
 Maximum value of SAR (measured) = 0.728 mW/g

143: Top of EUT Facing Phantom LTE FDD 25 20MHz 50%RB High CH26590 Sensor Active

Date: 23/04/2015

DUT: Inari 8; Type: Tablet

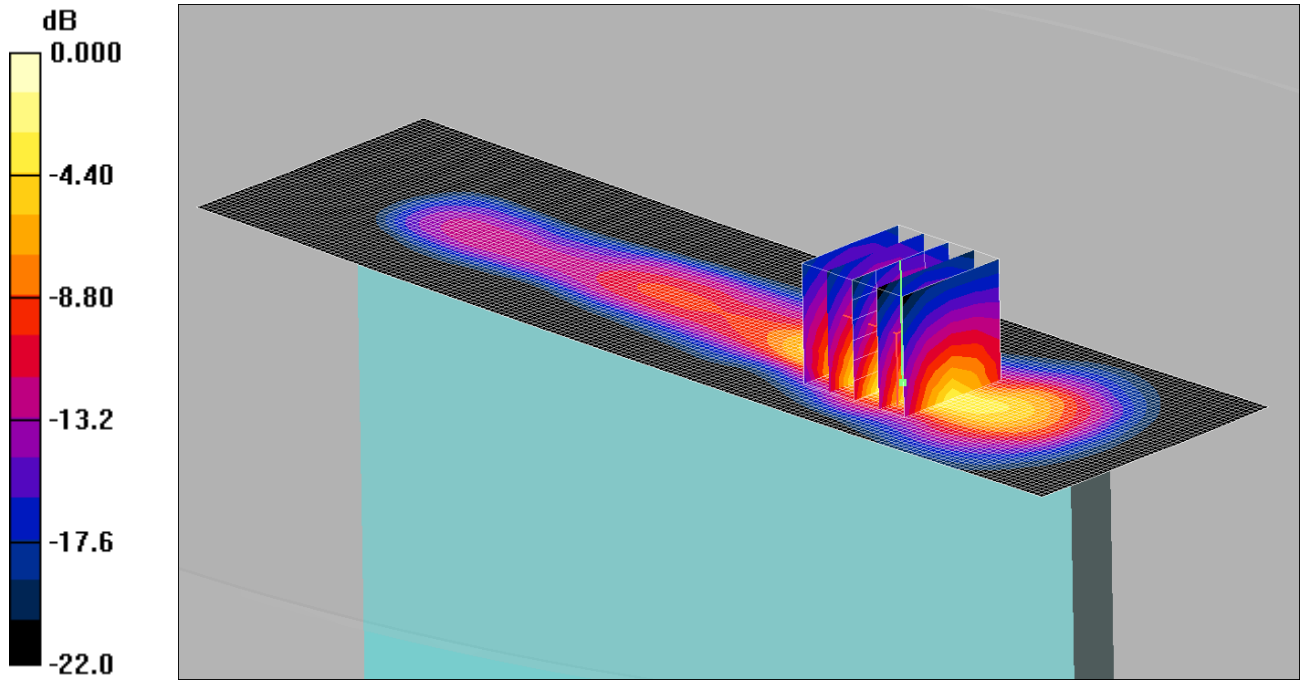

0 dB = 0.859mW/g

Communication System: LTE - Band 25 / 20MHz Channel; Frequency: 1905 MHz; Duty Cycle: 1:1
 Medium: 1900 MHz MSL Medium parameters used (interpolated): $f = 1905 \text{ MHz}$; $\sigma = 1.52 \text{ mho/m}$; $\epsilon_r = 52.6$; $\rho = 1000 \text{ kg/m}^3$

Phantom section: Flat Section

DASY4 Configuration:

- Probe: ES3DV3 - SN3304; ConvF(4.69, 4.69, 4.69);
- Sensor-Surface: 4mm (Mechanical Surface Detection)
- Electronics: DAE3 Sn432; Calibrated: 20/08/2014
- Phantom: ELI v5.0; Type: QDOVA002AA; Serial: TP:xxxx
- Measurement SW: DASY4, V4.7 Build 80; Postprocessing SW: SEMCAD, V1.8 Build 186

Top - High/Area Scan (51x181x1): Measurement grid: $dx=15\text{mm}$, $dy=15\text{mm}$
 Maximum value of SAR (interpolated) = 0.816 mW/g

Top - High/Zoom Scan (5x5x7) (5x5x7)/Cube 0: Measurement grid: $dx=8\text{mm}$, $dy=8\text{mm}$, $dz=5\text{mm}$

Reference Value = 24.3 V/m; Power Drift = 0.004 dB

Peak SAR (extrapolated) = 1.80 W/kg

SAR(1 g) = 0.763 mW/g; SAR(10 g) = 0.314 mW/g

Maximum value of SAR (measured) = 0.859 mW/g

144: Top of EUT Facing Phantom LTE FDD 25 20MHz 100%RB CH26365 Sensor Active

Date: 23/04/2015

DUT: Inari 8; Type: Tablet

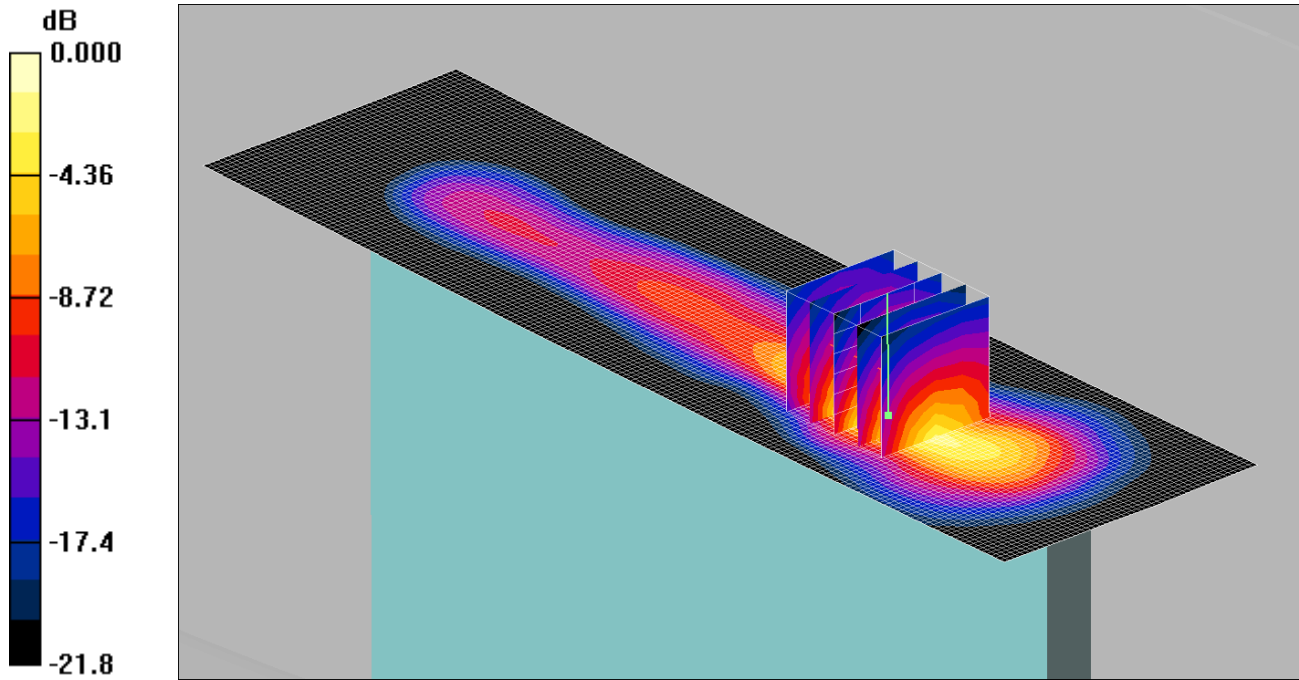

0 dB = 0.717mW/g

Communication System: LTE - Band 25 / 20MHz Channel; Frequency: 1882.5 MHz; Duty Cycle: 1:1
 Medium: 1900 MHz MSL Medium parameters used (interpolated): $f = 1882.5 \text{ MHz}$; $\sigma = 1.5 \text{ mho/m}$; $\epsilon_r = 52.6$; $\rho = 1000 \text{ kg/m}^3$

Phantom section: Flat Section

DASY4 Configuration:

- Probe: ES3DV3 - SN3304; ConvF(4.69, 4.69, 4.69);
- Sensor-Surface: 4mm (Mechanical Surface Detection)
- Electronics: DAE3 Sn432; Calibrated: 20/08/2014
- Phantom: ELI v5.0; Type: QDOVA002AA; Serial: TP:xxxx
- Measurement SW: DASY4, V4.7 Build 80; Postprocessing SW: SEMCAD, V1.8 Build 186

Top - Middle/Area Scan (51x181x1): Measurement grid: $dx=15\text{mm}$, $dy=15\text{mm}$
 Maximum value of SAR (interpolated) = 0.687 mW/g

Top - Middle/Zoom Scan (5x5x7) (5x5x7)/Cube 0: Measurement grid: $dx=8\text{mm}$, $dy=8\text{mm}$, $dz=5\text{mm}$

Reference Value = 22.5 V/m; Power Drift = 0.021 dB

Peak SAR (extrapolated) = 1.51 W/kg

SAR(1 g) = 0.639 mW/g; SAR(10 g) = 0.264 mW/g

Maximum value of SAR (measured) = 0.717 mW/g

145: Back of EUT Facing Phantom Wi-Fi 2.4GHz 802.11b 1Mbps SISO 2A CH11

Date: 25/03/2015

DUT: Inari 8; Type: Tablet

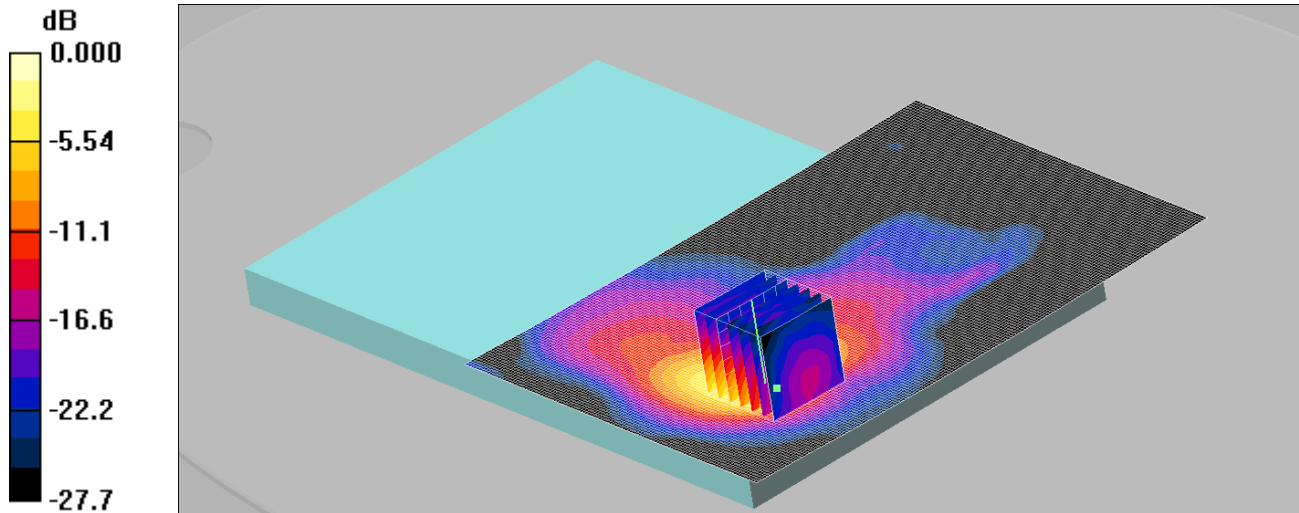

0 dB = 0.496mW/g

Communication System: WLAN; Frequency: 2462 MHz; Duty Cycle: 1:1

Medium: 2450 MHz MSL Medium parameters used (interpolated): $f = 2462$ MHz; $\sigma = 1.94$ mho/m; $\epsilon_r = 51.2$; $\rho = 1000$ kg/m³

Phantom section: Flat Section

DASY4 Configuration:

- Probe: ES3DV3 - SN3304; ConvF(4.24, 4.24, 4.24);
- Sensor-Surface: 4mm (Mechanical Surface Detection)
- Electronics: DAE3 Sn432; Calibrated: 20/08/2014
- Phantom: ELI v5.0; Type: QDOVA002AA; Serial: TP:xxxx
- Measurement SW: DASY4, V4.7 Build 80; Postprocessing SW: SEMCAD, V1.8 Build 186

Back - Middle 2 2 /Area Scan 2 2 (161x111x1): Measurement grid: dx=12mm, dy=12mm

Maximum value of SAR (interpolated) = 0.442 mW/g

Back - Middle 2 2 /Zoom Scan (7x7x7) 2 (7x7x7)/Cube 0: Measurement grid: dx=5mm, dy=5mm, dz=5mm

Reference Value = 13.8 V/m; Power Drift = -0.054 dB

Peak SAR (extrapolated) = 1.31 W/kg

SAR(1 g) = 0.427 mW/g; SAR(10 g) = 0.161 mW/g

Maximum value of SAR (measured) = 0.496 mW/g

146: Right of EUT Facing Phantom Wi-Fi 2.4GHz 802.11b 1Mbps SISO 2A CH11

Date: 25/03/2015

DUT: Inari 8; Type: Tablet

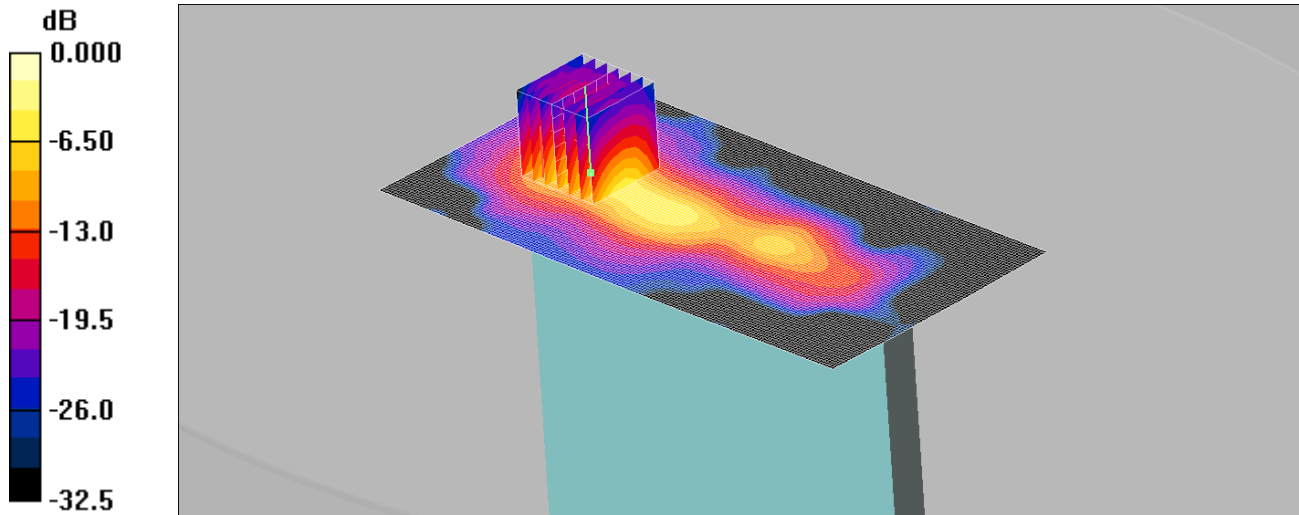

0 dB = 0.466mW/g

Communication System: WLAN; Frequency: 2462 MHz; Duty Cycle: 1:1

Medium: 2450 MHz MSL Medium parameters used (interpolated): $f = 2462$ MHz; $\sigma = 1.94$ mho/m; $\epsilon_r = 51.2$; $\rho = 1000$ kg/m³

Phantom section: Flat Section

DASY4 Configuration:

- Probe: ES3DV3 - SN3304; ConvF(4.24, 4.24, 4.24);
- Sensor-Surface: 4mm (Mechanical Surface Detection)
- Electronics: DAE3 Sn432; Calibrated: 20/08/2014
- Phantom: ELI v5.0; Type: QDOVA002AA; Serial: TP:xxxx
- Measurement SW: DASY4, V4.7 Build 80; Postprocessing SW: SEMCAD, V1.8 Build 186

Back - Middle 2 2 /Area Scan 2 3 (81x161x1): Measurement grid: dx=12mm, dy=12mm

Maximum value of SAR (interpolated) = 0.419 mW/g

Back - Middle 2 2 /Zoom Scan (7x7x7) (7x7x7)/Cube 0: Measurement grid: dx=5mm, dy=5mm, dz=5mm

Reference Value = 5.74 V/m; Power Drift = 0.073 dB

Peak SAR (extrapolated) = 1.01 W/kg

SAR(1 g) = 0.382 mW/g; SAR(10 g) = 0.133 mW/g

Maximum value of SAR (measured) = 0.466 mW/g

147: Back of EUT Facing Phantom Wi-Fi 2.4GHz 802.11b 1Mbps SISO 2B CH11

Date: 26/03/2015

DUT: Inari 8; Type: Tablet

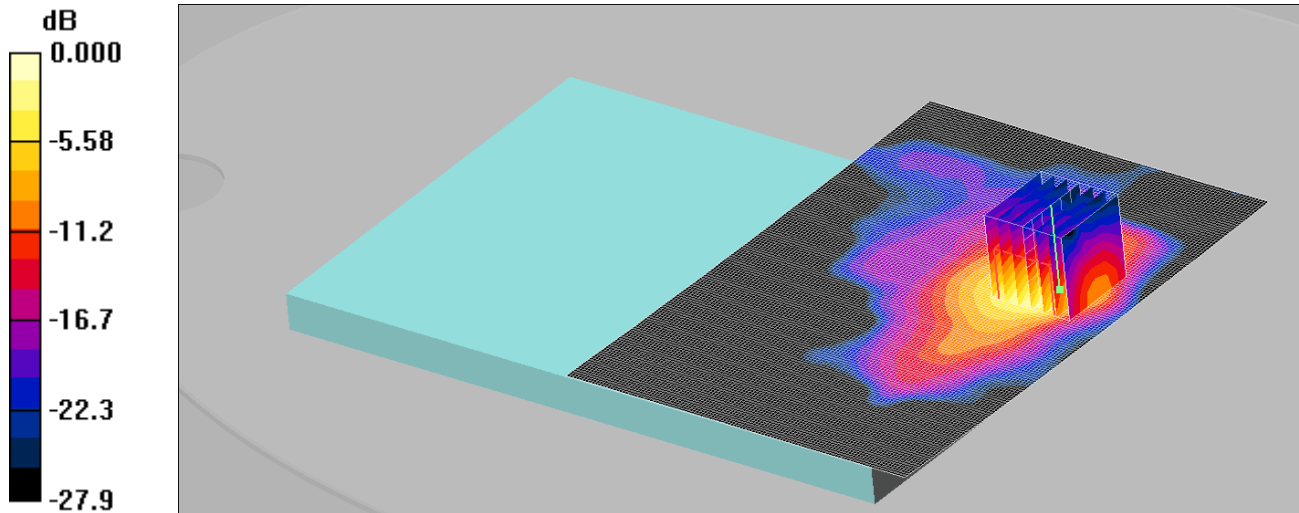

0 dB = 0.308mW/g

Communication System: WLAN; Frequency: 2462 MHz; Duty Cycle: 1:1

Medium: 2450 MHz MSL Medium parameters used (interpolated): $f = 2462$ MHz; $\sigma = 2.03$ mho/m; $\epsilon_r = 50.3$; $\rho = 1000$ kg/m³

Phantom section: Flat Section

DASY4 Configuration:

- Probe: ES3DV3 - SN3304; ConvF(4.24, 4.24, 4.24);
- Sensor-Surface: 4mm (Mechanical Surface Detection)
- Electronics: DAE3 Sn432; Calibrated: 20/08/2014
- Phantom: ELI v5.0; Type: QDOVA002AA; Serial: TP:xxxx
- Measurement SW: DASY4, V4.7 Build 80; Postprocessing SW: SEMCAD, V1.8 Build 186

Back - Middle 2 2 /Area Scan 2 2 (161x111x1): Measurement grid: dx=12mm, dy=12mm

Maximum value of SAR (interpolated) = 0.366 mW/g

Back - Middle 2 2 /Zoom Scan (7x7x7) (7x7x7)/Cube 0: Measurement grid: dx=5mm, dy=5mm, dz=5mm

Reference Value = 9.37 V/m; Power Drift = -0.020 dB

Peak SAR (extrapolated) = 0.772 W/kg

SAR(1 g) = 0.265 mW/g; SAR(10 g) = 0.103 mW/g

Maximum value of SAR (measured) = 0.308 mW/g

148: Right of EUT Facing Phantom Wi-Fi 2.4GHz 802.11b 1Mbps SISO 2B CH11

Date: 26/03/2015

DUT: Inari 8; Type: Tablet

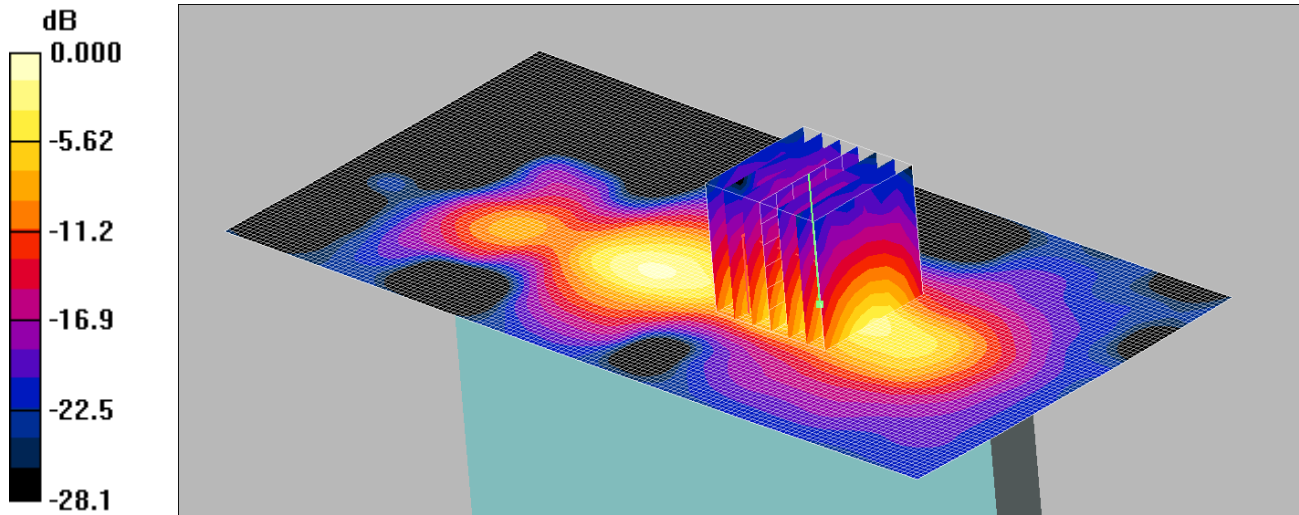

0 dB = 0.210mW/g

Communication System: WLAN; Frequency: 2462 MHz; Duty Cycle: 1:1

Medium: 2450 MHz MSL Medium parameters used (interpolated): $f = 2462$ MHz; $\sigma = 1.94$ mho/m; $\epsilon_r = 51.2$; $\rho = 1000$ kg/m³

Phantom section: Flat Section

DASY4 Configuration:

- Probe: ES3DV3 - SN3304; ConvF(4.24, 4.24, 4.24);
- Sensor-Surface: 4mm (Mechanical Surface Detection)
- Electronics: DAE3 Sn432; Calibrated: 20/08/2014
- Phantom: ELI v5.0; Type: QDOVA002AA; Serial: TP:xxxx
- Measurement SW: DASY4, V4.7 Build 80; Postprocessing SW: SEMCAD, V1.8 Build 186

Right - Middle/Area Scan 2 3 (81x161x1): Measurement grid: dx=12mm, dy=12mm

Maximum value of SAR (interpolated) = 0.203 mW/g

Right - Middle/Zoom Scan (7x7x7) (7x7x7)/Cube 0: Measurement grid: dx=5mm, dy=5mm, dz=5mm

Reference Value = 5.39 V/m; Power Drift = -0.080 dB

Peak SAR (extrapolated) = 0.433 W/kg

SAR(1 g) = 0.175 mW/g; SAR(10 g) = 0.067 mW/g

Maximum value of SAR (measured) = 0.210 mW/g

149: Back of EUT Facing Phantom Wi-Fi 2.4GHz 802.11g CDD 6Mbps MIMO 2AB-A CH11

Date: 26/03/2015

DUT: Inari 8; Type: Tablet

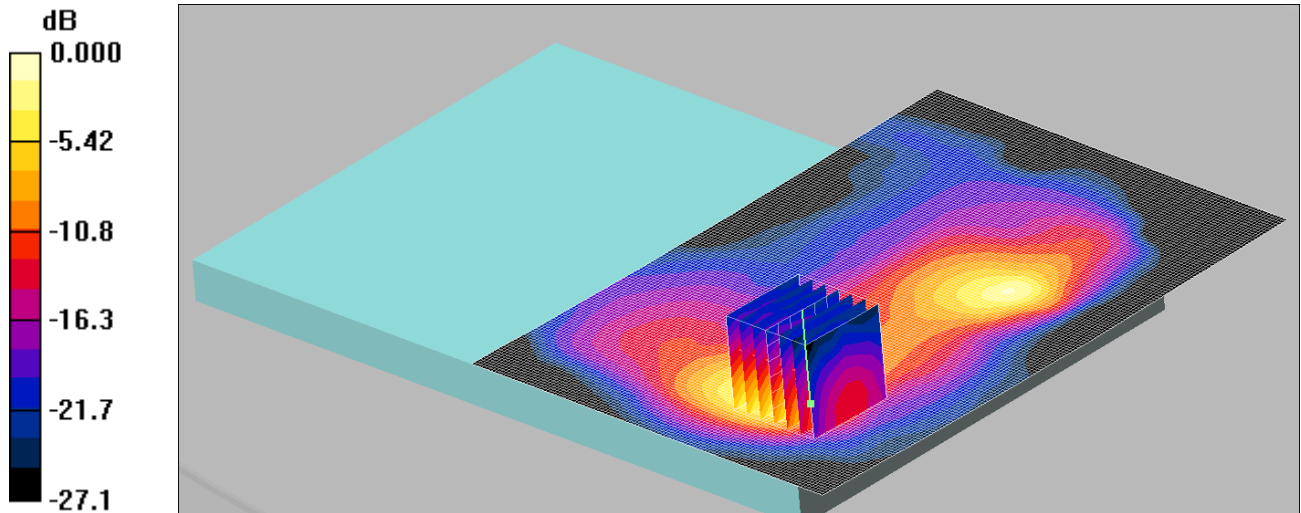

0 dB = 0.530mW/g

Communication System: WLAN; Frequency: 2462 MHz; Duty Cycle: 1:1

Medium: 2450 MHz MSL Medium parameters used (interpolated): $f = 2462$ MHz; $\sigma = 2.03$ mho/m; $\epsilon_r = 50.3$; $\rho = 1000$ kg/m³

Phantom section: Flat Section

DASY4 Configuration:

- Probe: ES3DV3 - SN3304; ConvF(4.24, 4.24, 4.24);
- Sensor-Surface: 4mm (Mechanical Surface Detection)
- Electronics: DAE3 Sn432; Calibrated: 20/08/2014
- Phantom: ELI v5.0; Type: QDOVA002AA; Serial: TP:xxxx
- Measurement SW: DASY4, V4.7 Build 80; Postprocessing SW: SEMCAD, V1.8 Build 186

Back - Middle 2 2 /Area Scan 2 2 (161x111x1): Measurement grid: dx=12mm, dy=12mm

Maximum value of SAR (interpolated) = 0.531 mW/g

Back - Middle 2 2 /Zoom Scan (7x7x7) (7x7x7)/Cube 0: Measurement grid: dx=5mm, dy=5mm, dz=5mm

Reference Value = 12.6 V/m; Power Drift = 0.052 dB

Peak SAR (extrapolated) = 1.30 W/kg

SAR(1 g) = 0.434 mW/g; SAR(10 g) = 0.173 mW/g

Maximum value of SAR (measured) = 0.530 mW/g

150: Right of EUT Facing Phantom Wi-Fi 2.4GHz 802.11g CDD 6Mbps MIMO 2AB-A CH11

Date: 26/03/2015

DUT: Inari 8; Type: Tablet

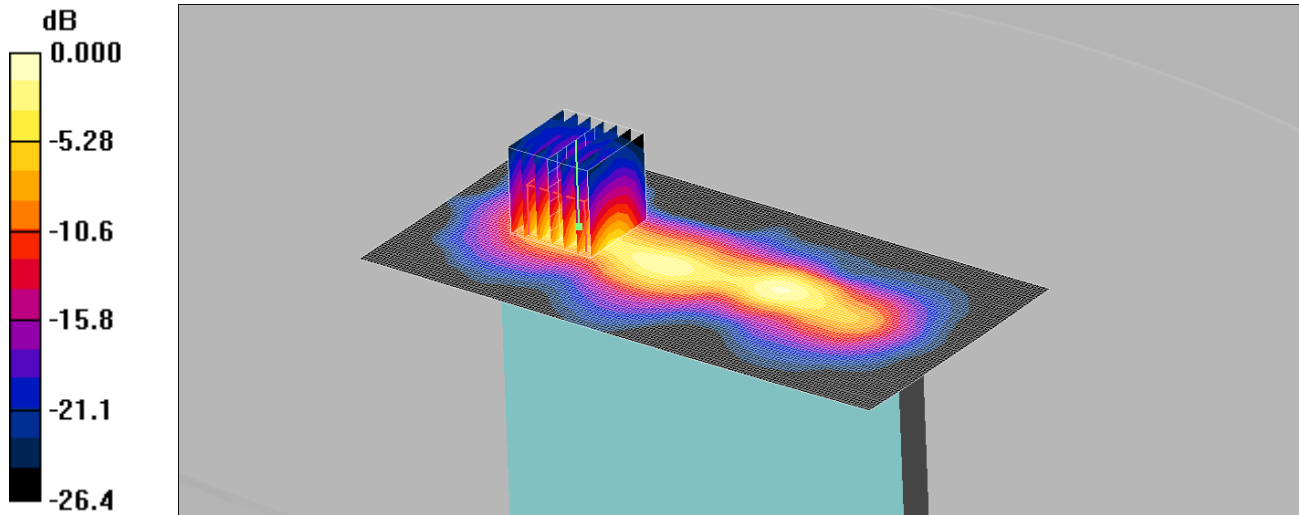

0 dB = 0.484mW/g

Communication System: WLAN; Frequency: 2462 MHz; Duty Cycle: 1:1

Medium: 2450 MHz MSL Medium parameters used (interpolated): $f = 2462$ MHz; $\sigma = 2.03$ mho/m; $\epsilon_r = 50.3$; $\rho = 1000$ kg/m³

Phantom section: Flat Section

DASY4 Configuration:

- Probe: ES3DV3 - SN3304; ConvF(4.24, 4.24, 4.24);
- Sensor-Surface: 4mm (Mechanical Surface Detection)
- Electronics: DAE3 Sn432; Calibrated: 20/08/2014
- Phantom: ELI v5.0; Type: QDOVA002AA; Serial: TP:xxxx
- Measurement SW: DASY4, V4.7 Build 80; Postprocessing SW: SEMCAD, V1.8 Build 186

Right - Middle/Area Scan 2 3 (81x161x1): Measurement grid: dx=12mm, dy=12mm

Maximum value of SAR (interpolated) = 0.393 mW/g

Right - Middle/Zoom Scan (7x7x7) (7x7x7)/Cube 0: Measurement grid: dx=5mm, dy=5mm, dz=5mm

Reference Value = 9.04 V/m; Power Drift = 0.016 dB

Peak SAR (extrapolated) = 0.994 W/kg

SAR(1 g) = 0.387 mW/g; SAR(10 g) = 0.140 mW/g

Maximum value of SAR (measured) = 0.484 mW/g

151: Back of EUT Facing Phantom Wi-Fi 2.4GHz 802.11g CDD 6Mbps MIMO 2AB-B CH1

Date: 17/04/2015

DUT: Inari 8; Type: Tablet

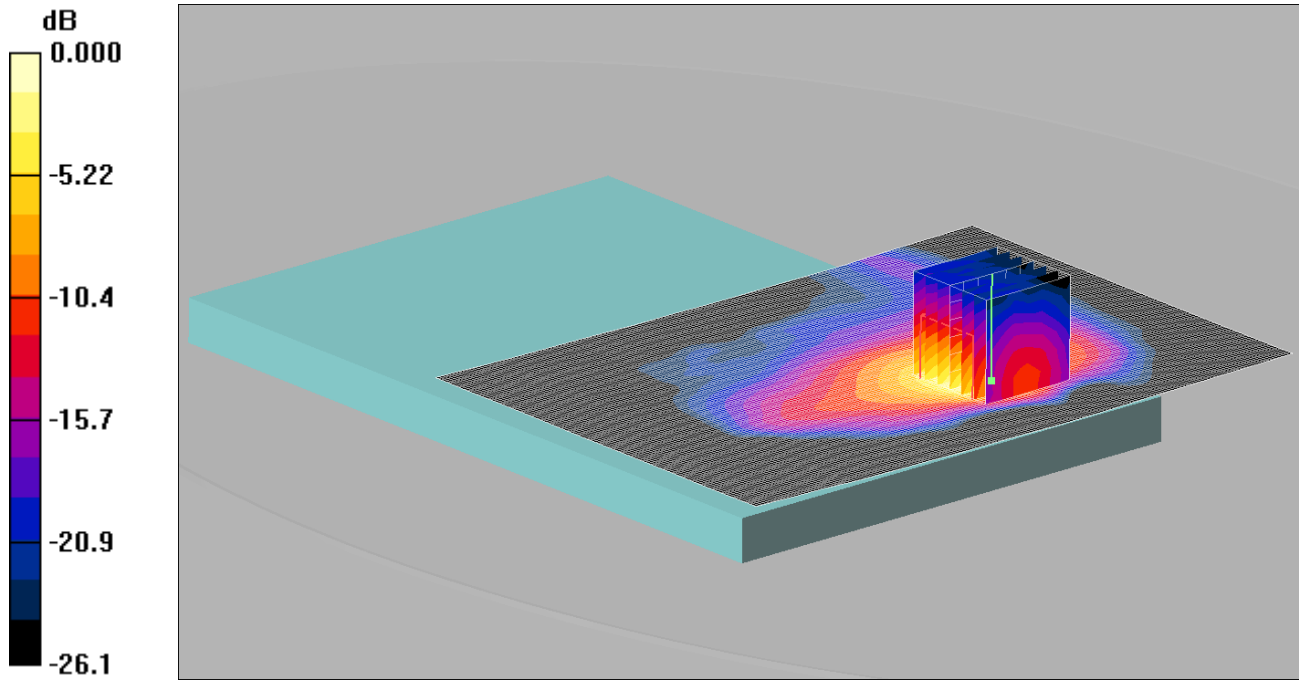

0 dB = 0.415mW/g

Communication System: WLAN; Frequency: 2412 MHz; Duty Cycle: 1:1

Medium: 2450 MHz MSL Medium parameters used (interpolated): $f = 2412$ MHz; $\sigma = 1.87$ mho/m; $\epsilon_r = 51.3$; $\rho = 1000$ kg/m³

Phantom section: Flat Section

DASY4 Configuration:

- Probe: ES3DV3 - SN3304; ConvF(4.24, 4.24, 4.24);
- Sensor-Surface: 4mm (Mechanical Surface Detection)
- Electronics: DAE3 Sn432; Calibrated: 20/08/2014
- Phantom: ELI v5.0; Type: QDOVA002AA; Serial: TP:xxxx
- Measurement SW: DASY4, V4.7 Build 80; Postprocessing SW: SEMCAD, V1.8 Build 186

Back - Low/Area Scan (161x111x1): Measurement grid: dx=12mm, dy=12mm
 Maximum value of SAR (interpolated) = 0.474 mW/g

Back - Low/Zoom Scan (7x7x7) (7x7x7)/Cube 0: Measurement grid: dx=5mm, dy=5mm, dz=5mm

Reference Value = 13.2 V/m; Power Drift = -0.027 dB

Peak SAR (extrapolated) = 1.01 W/kg

SAR(1 g) = 0.347 mW/g; SAR(10 g) = 0.135 mW/g

Maximum value of SAR (measured) = 0.415 mW/g

152: Back of EUT Facing Phantom Wi-Fi 2.4GHz 802.11g CDD 6Mbps MIMO 2AB-B CH6

Date: 17/04/2015

DUT: Inari 8; Type: Tablet

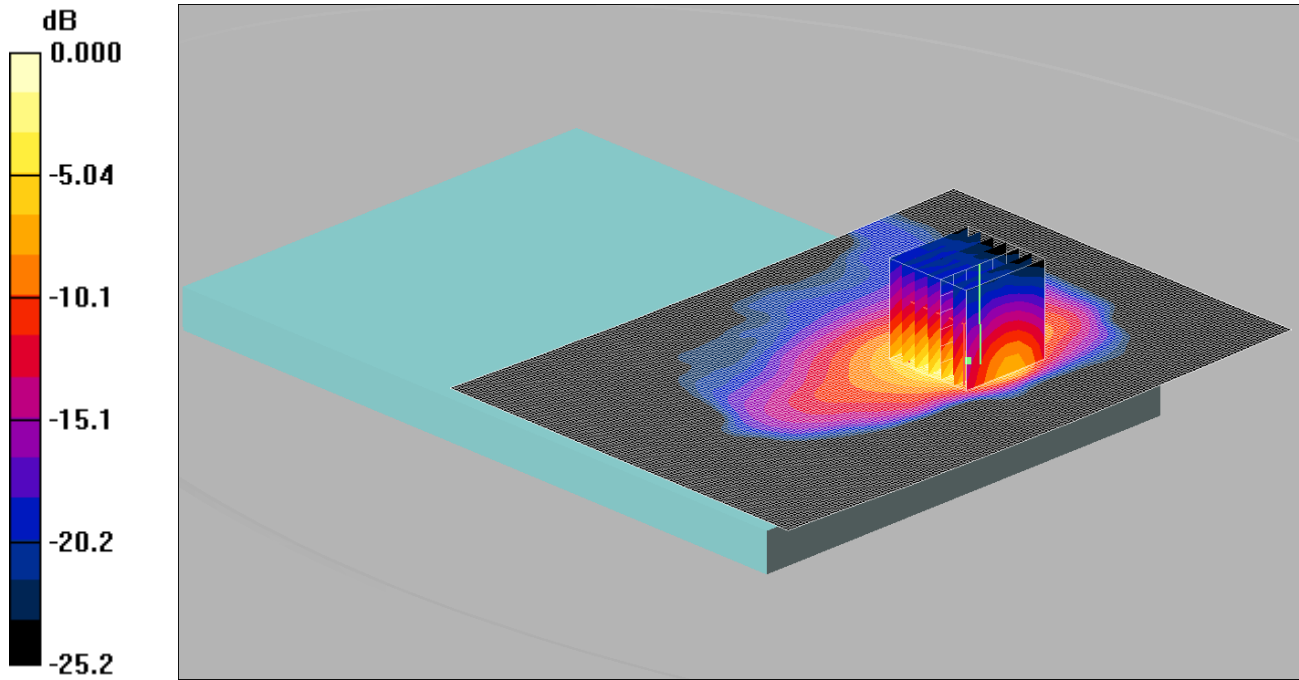

0 dB = 0.382mW/g

Communication System: WLAN; Frequency: 2437 MHz; Duty Cycle: 1:1

Medium: 2450 MHz MSL Medium parameters used (interpolated): $f = 2437$ MHz; $\sigma = 1.91$ mho/m; $\epsilon_r = 51.3$; $\rho = 1000$ kg/m³

Phantom section: Flat Section

DASY4 Configuration:

- Probe: ES3DV3 - SN3304; ConvF(4.24, 4.24, 4.24);
- Sensor-Surface: 4mm (Mechanical Surface Detection)
- Electronics: DAE3 Sn432; Calibrated: 20/08/2014
- Phantom: ELI v5.0; Type: QDOVA002AA; Serial: TP:xxxx
- Measurement SW: DASY4, V4.7 Build 80; Postprocessing SW: SEMCAD, V1.8 Build 186

Back - Middle/Area Scan (161x111x1): Measurement grid: dx=12mm, dy=12mm
 Maximum value of SAR (interpolated) = 0.367 mW/g

Back - Middle/Zoom Scan (7x7x7) (7x7x7)/Cube 0: Measurement grid: dx=5mm, dy=5mm, dz=5mm

Reference Value = 14.3 V/m; Power Drift = -0.009 dB

Peak SAR (extrapolated) = 0.979 W/kg

SAR(1 g) = 0.331 mW/g; SAR(10 g) = 0.128 mW/g

Maximum value of SAR (measured) = 0.382 mW/g

153: Back of EUT Facing Phantom Wi-Fi 5GHz 802.11a 6Mbps SISO 2A CH36

Date: 18/04/15

DUT: Inari 8; Type: Tablet

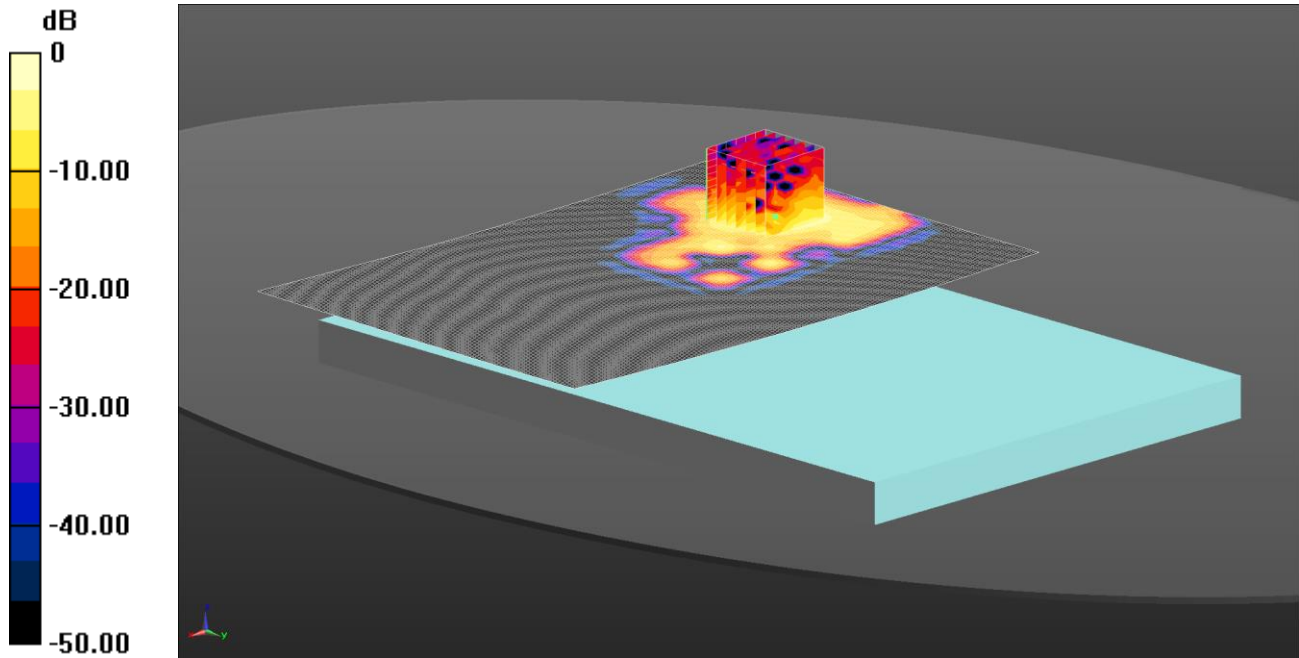

0 dB = 0.876 W/kg = -0.57 dBW/kg

Communication System: UID 0, WLAN 802.11 (0); Frequency: 5180 MHz; Duty Cycle: 1:1

Medium: 5GHz MSL Medium parameters used (interpolated): $f = 5180$ MHz; $\sigma = 5.287$ S/m; $\epsilon_r = 47.974$; $\rho = 1000$ kg/m³

Phantom section: Flat Section

DASY4 Configuration:

- Probe: EX3DV4 - SN3814; ConvF(4.38, 4.38, 4.38); Calibrated: 18/09/14;
- Sensor-Surface: 4mm (Mechanical Surface Detection)
- Electronics: DAE4 Sn1435; Calibrated: 20/02/15
- Phantom: ELI v5.0 (30deg probe tilt); Type: QDOVA002AA; Serial: TP:xxxx
- ; SEMCAD X Version 14.6.10 (7331)

Configuration/Back of EUT Facing Phantom - Middle/Area Scan (191x131x1): Interpolated grid: dx=1.000 mm, dy=1.000 mm

Maximum value of SAR (interpolated) = 0.921 W/kg

Configuration/Back of EUT Facing Phantom - Middle/Zoom Scan (7x7x12) 2 (7x7x12)/Cube 0: Measurement grid:

dx=4mm, dy=4mm, dz=2mm

Reference Value = 7.405 V/m; Power Drift = 0.03 dB

Peak SAR (extrapolated) = 1.99 W/kg

SAR(1 g) = 0.697 W/kg; SAR(10 g) = 0.212 W/kg

Maximum value of SAR (measured) = 0.876 W/kg

154: Right of EUT Facing Phantom Wi-Fi 5GHz 802.11a 6Mbps SISO 2A CH36

Date: 17/04/15

DUT: Inari 8; Type: Tablet

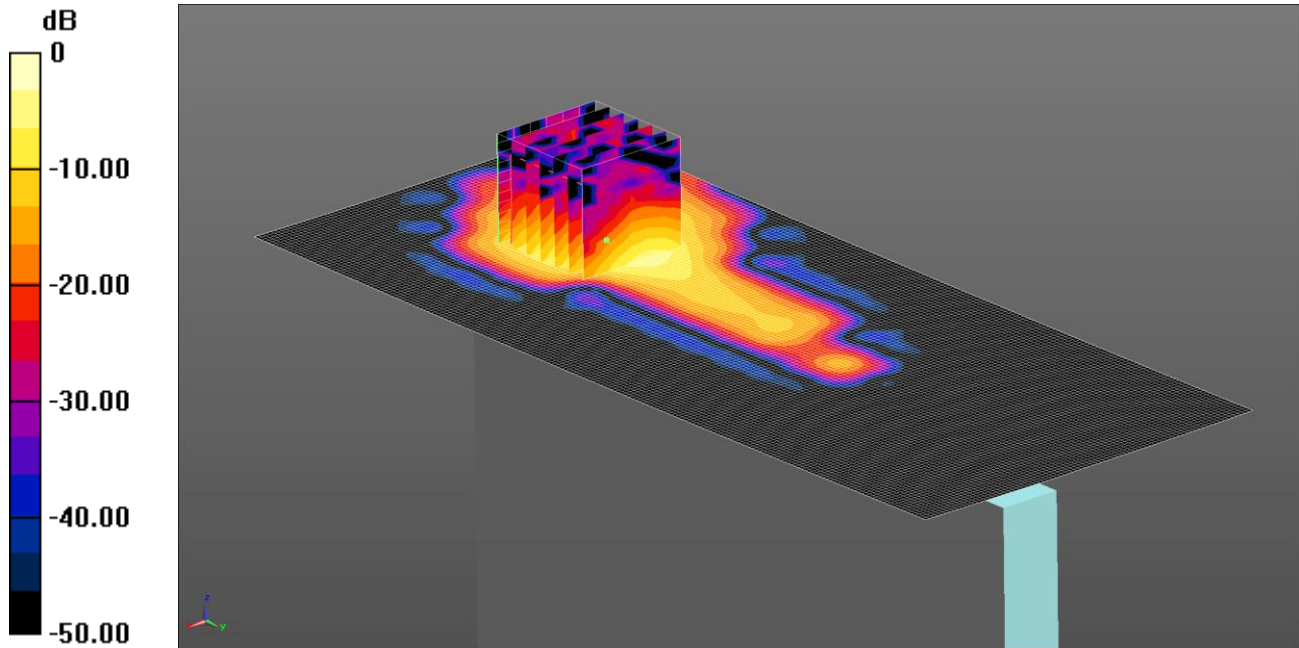

0 dB = 1.36 W/kg = 1.34 dBW/kg

Communication System: UID 0, WLAN 802.11 (0); Frequency: 5180 MHz; Duty Cycle: 1:1

Medium: 5GHz MSL Medium parameters used (interpolated): $f = 5180$ MHz; $\sigma = 5.287$ S/m; $\epsilon_r = 47.974$; $\rho = 1000$ kg/m³

Phantom section: Flat Section

DASY4 Configuration:

- Probe: EX3DV4 - SN3814; ConvF(4.38, 4.38, 4.38); Calibrated: 18/09/14;
- Sensor-Surface: 4mm (Mechanical Surface Detection)
- Electronics: DAE4 Sn1435; Calibrated: 20/02/15
- Phantom: ELI v5.0 (30deg probe tilt); Type: QDOVA002AA; Serial: TP:xxxx
- ; SEMCAD X Version 14.6.10 (7331)

Configuration/Right of EUT Facing Phantom - Middle Sample 2 2 2 2/Area Scan (81x191x1): Interpolated grid: dx=1.000 mm, dy=1.000 mm

Maximum value of SAR (interpolated) = 1.29 W/kg

Configuration/Right of EUT Facing Phantom - Middle Sample 2 2 2 2/Zoom Scan (7x7x12) (7x7x12)/Cube 0:

Measurement grid: dx=4mm, dy=4mm, dz=2mm

Reference Value = 14.81 V/m; Power Drift = -0.06 dB

Peak SAR (extrapolated) = 3.00 W/kg

SAR(1 g) = 1.02 W/kg; SAR(10 g) = 0.284 W/kg

Maximum value of SAR (measured) = 1.36 W/kg

155: Right of EUT Facing Phantom Wi-Fi 5GHz 802.11a 6Mbps SISO 2A CH48

Date: 18/04/15

DUT: Inari 8; Type: Tablet

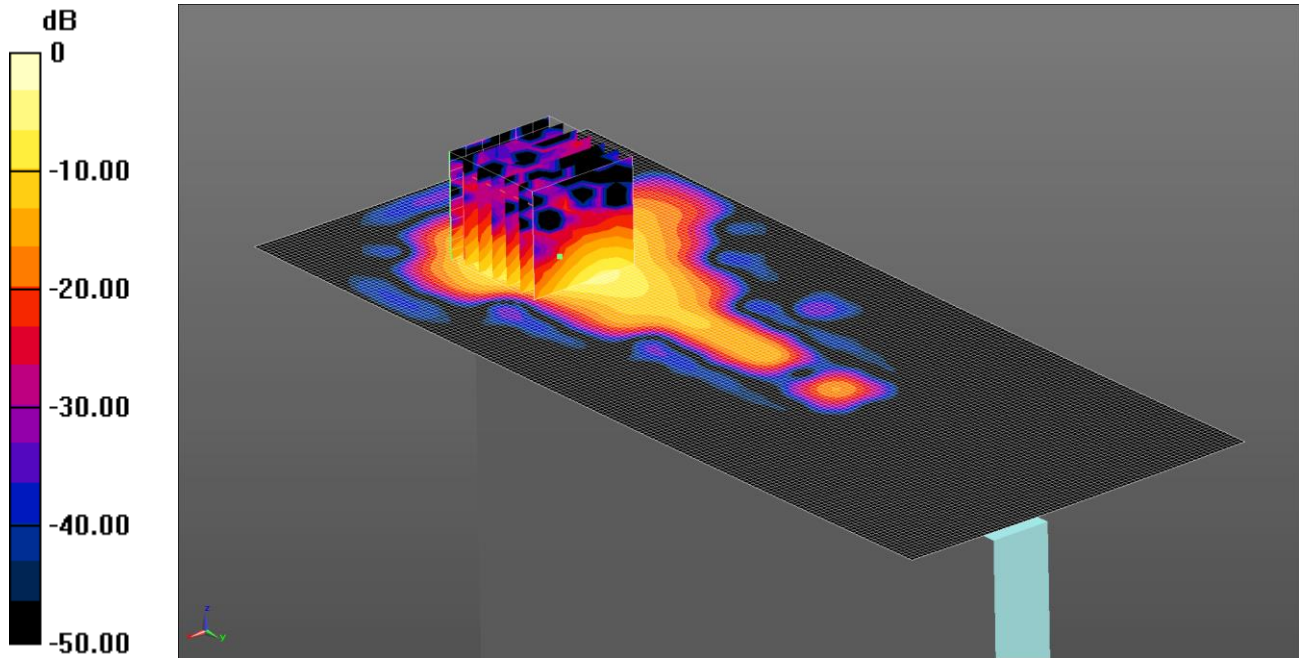

0 dB = 1.70 W/kg = 2.30 dBW/kg

Communication System: UID 0, WLAN 802.11 (0); Frequency: 5240 MHz; Duty Cycle: 1:1

Medium: 5GHz MSL Medium parameters used (interpolated): $f = 5240$ MHz; $\sigma = 5.383$ S/m; $\epsilon_r = 47.798$; $\rho = 1000$ kg/m³

Phantom section: Flat Section

DASY4 Configuration:

- Probe: EX3DV4 - SN3814; ConvF(4.38, 4.38, 4.38); Calibrated: 18/09/14;
- Sensor-Surface: 4mm (Mechanical Surface Detection)
- Electronics: DAE4 Sn1435; Calibrated: 20/02/15
- Phantom: ELI v5.0 (30deg probe tilt); Type: QDOVA002AA; Serial: TP:xxxx
- ; SEMCAD X Version 14.6.10 (7331)

Configuration/Right of EUT Facing Phantom - Middle 2/Area Scan (81x191x1): Interpolated grid: dx=1.000 mm, dy=1.000 mm

Maximum value of SAR (interpolated) = 1.71 W/kg

Configuration/Right of EUT Facing Phantom - Middle 2/Zoom Scan (7x7x12) 2 (7x7x12)/Cube 0: Measurement grid: dx=4mm, dy=4mm, dz=2mm

Reference Value = 18.28 V/m; Power Drift = 0.01 dB

Peak SAR (extrapolated) = 4.02 W/kg

SAR(1 g) = 1.27 W/kg; SAR(10 g) = 0.337 W/kg

Maximum value of SAR (measured) = 1.70 W/kg

156: Top of EUT Facing Phantom Wi-Fi 5GHz 802.11a 6Mbps SISO 2A CH36

Date: 21/04/15

DUT: Inari 8; Type: Tablet

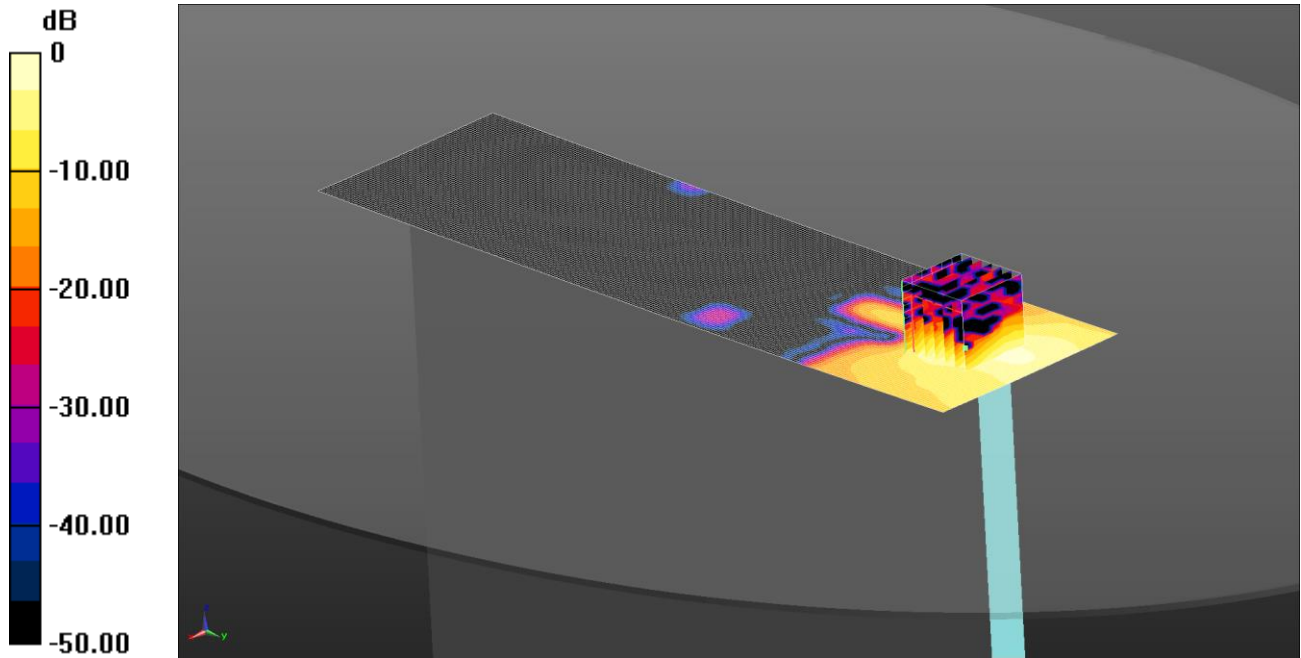

0 dB = 0.365 W/kg = -4.38 dBW/kg

Communication System: UID 0, WLAN 802.11 (0); Frequency: 5180 MHz; Duty Cycle: 1:1

Medium: 5GHz MSL Medium parameters used (interpolated): $f = 5180$ MHz; $\sigma = 5.208$ S/m; $\epsilon_r = 47.273$; $\rho = 1000$ kg/m³

Phantom section: Flat Section

DASY4 Configuration:

- Probe: EX3DV4 - SN3814; ConvF(4.38, 4.38, 4.38); Calibrated: 18/09/14;
- Sensor-Surface: 4mm (Mechanical Surface Detection)
- Electronics: DAE4 Sn1435; Calibrated: 20/02/15
- Phantom: ELI v5.0 (30deg probe tilt); Type: QDOVA002AA; Serial: TP:xxxx
- ; SEMCAD X Version 14.6.10 (7331)

Configuration/Top of EUT Facing Phantom - Middle/Area Scan (71x251x1): Interpolated grid: dx=1.000 mm, dy=1.000 mm

Maximum value of SAR (interpolated) = 0.340 W/kg

Configuration/Top of EUT Facing Phantom - Middle/Zoom Scan (7x7x12) 2 (7x7x12)/Cube 0: Measurement grid:

dx=4mm, dy=4mm, dz=2mm

Reference Value = 7.470 V/m; Power Drift = -0.18 dB

Peak SAR (extrapolated) = 0.724 W/kg

SAR(1 g) = 0.261 W/kg; SAR(10 g) = 0.074 W/kg

Maximum value of SAR (measured) = 0.365 W/kg

157: Back of EUT Facing Phantom Wi-Fi 5GHz 802.11a 6Mbps SISO 2B CH48

Date: 21/04/15

DUT: Inari 8; Type: Tablet

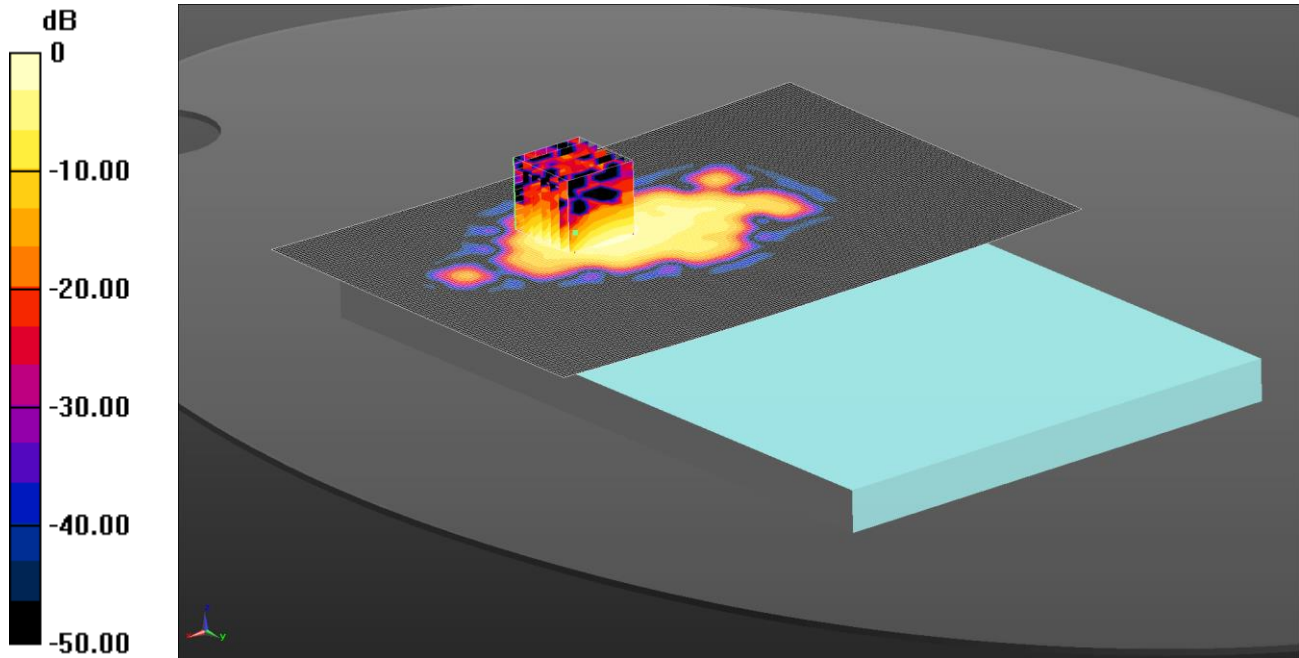

0 dB = 0.300 W/kg = -5.23 dBW/kg

Communication System: UID 0, WLAN 802.11 (0); Frequency: 5240 MHz; Duty Cycle: 1:1

Medium: 5GHz MSL Medium parameters used (interpolated): $f = 5240$ MHz; $\sigma = 5.322$ S/m; $\epsilon_r = 47.143$; $\rho = 1000$ kg/m³

Phantom section: Flat Section

DASY4 Configuration:

- Probe: EX3DV4 - SN3814; ConvF(4.38, 4.38, 4.38); Calibrated: 18/09/14;
- Sensor-Surface: 4mm (Mechanical Surface Detection)
- Electronics: DAE4 Sn1435; Calibrated: 20/02/15
- Phantom: ELI v5.0 (30deg probe tilt); Type: QDOVA002AA; Serial: TP:xxxx
- ; SEMCAD X Version 14.6.10 (7331)

Configuration/Back of EUT Facing Phantom - Middle/Area Scan (191x131x1): Interpolated grid: dx=1.000 mm, dy=1.000 mm

Maximum value of SAR (interpolated) = 0.326 W/kg

Configuration/Back of EUT Facing Phantom - Middle/Zoom Scan (7x7x12) 2 (7x7x12)/Cube 0: Measurement grid: dx=4mm, dy=4mm, dz=2mm

Reference Value = 7.259 V/m; Power Drift = 0.06 dB

Peak SAR (extrapolated) = 0.807 W/kg

SAR(1 g) = 0.255 W/kg; SAR(10 g) = 0.080 W/kg

Maximum value of SAR (measured) = 0.300 W/kg

158: Right of EUT Facing Phantom Wi-Fi 5GHz 802.11a 6Mbps SISO 2B CH48

Date: 21/04/15

DUT: Inari 8; Type: Tablet

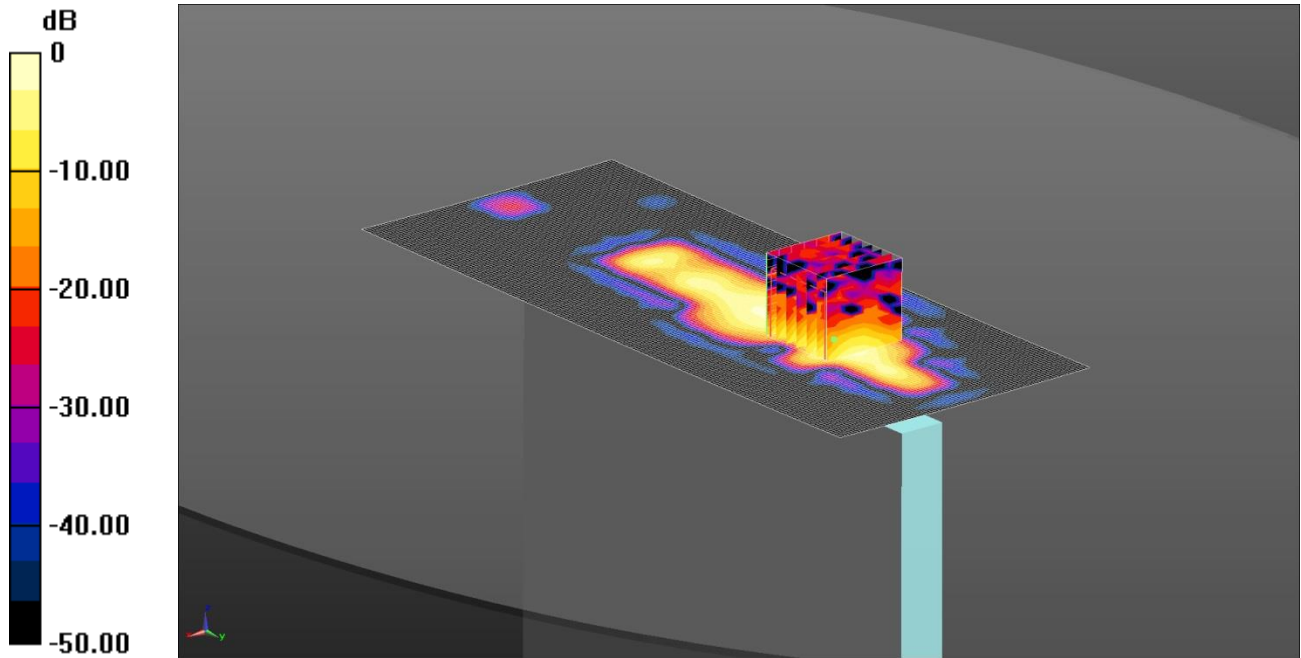

0 dB = 0.379 W/kg = -4.21 dBW/kg

Communication System: UID 0, WLAN 802.11 (0); Frequency: 5240 MHz; Duty Cycle: 1:1

Medium: 5GHz MSL Medium parameters used (interpolated): $f = 5240$ MHz; $\sigma = 5.322$ S/m; $\epsilon_r = 47.143$; $\rho = 1000$ kg/m³

Phantom section: Flat Section

DASY4 Configuration:

- Probe: EX3DV4 - SN3814; ConvF(4.38, 4.38, 4.38); Calibrated: 18/09/14;
- Sensor-Surface: 4mm (Mechanical Surface Detection)
- Electronics: DAE4 Sn1435; Calibrated: 20/02/15
- Phantom: ELI v5.0 (30deg probe tilt); Type: QDOVA002AA; Serial: TP:xxxx
- ; SEMCAD X Version 14.6.10 (7331)

Configuration/Right of EUT Facing Phantom - Middle 2/Area Scan (81x191x1): Interpolated grid: dx=1.000 mm, dy=1.000 mm

Maximum value of SAR (interpolated) = 0.489 W/kg

Configuration/Right of EUT Facing Phantom - Middle 2/Zoom Scan (7x7x12) 2 (7x7x12)/Cube 0: Measurement grid:

dx=4mm, dy=4mm, dz=2mm

Reference Value = 6.940 V/m; Power Drift = 0.14 dB

Peak SAR (extrapolated) = 1.02 W/kg

SAR(1 g) = 0.295 W/kg; SAR(10 g) = 0.082 W/kg

Maximum value of SAR (measured) = 0.379 W/kg

159: Right of EUT Facing Phantom Wi-Fi 5GHz 802.11a CDD 6Mbps MIMO 2AB-A CH36

Date: 21/04/15

DUT: Inari 8; Type: Tablet

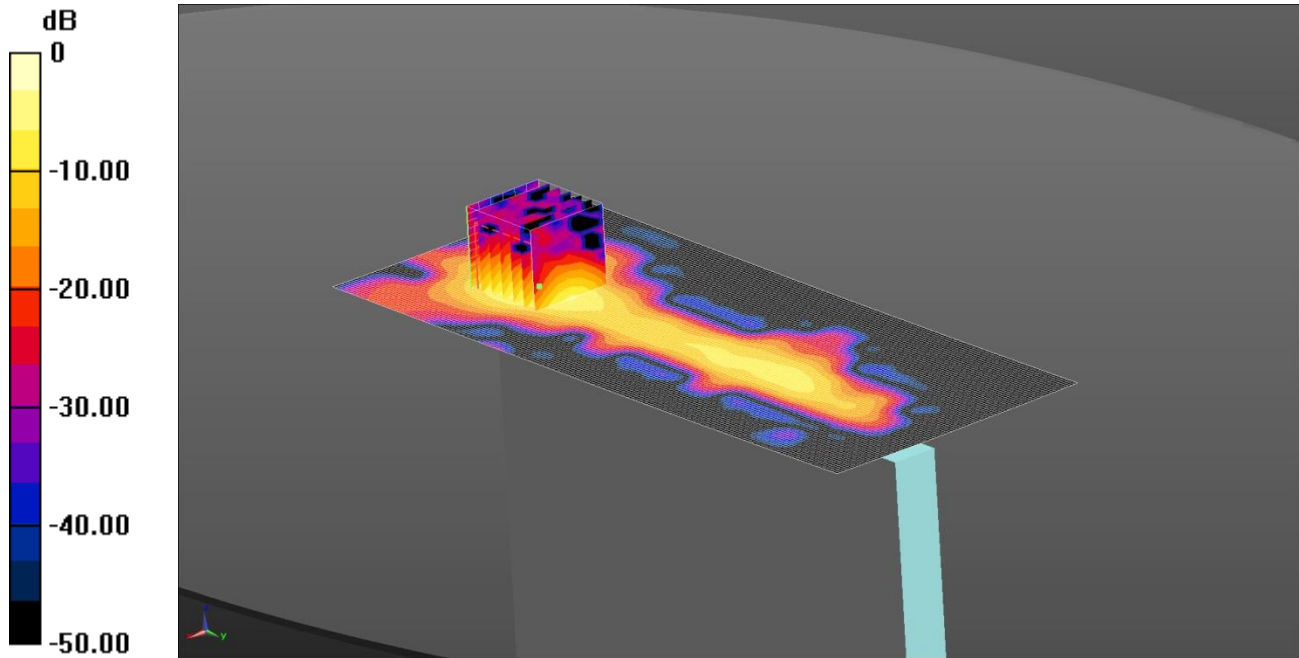

0 dB = 1.66 W/kg = 2.20 dBW/kg

Communication System: UID 0, WLAN 802.11 (0); Frequency: 5180 MHz; Duty Cycle: 1:1

Medium: 5GHz MSL Medium parameters used (interpolated): $f = 5180 \text{ MHz}$; $\sigma = 5.208 \text{ S/m}$; $\epsilon_r = 47.273$; $\rho = 1000 \text{ kg/m}^3$

Phantom section: Flat Section

DASY4 Configuration:

- Probe: EX3DV4 - SN3814; ConvF(4.38, 4.38, 4.38); Calibrated: 18/09/14;
- Sensor-Surface: 4mm (Mechanical Surface Detection)
- Electronics: DAE4 Sn1435; Calibrated: 20/02/15
- Phantom: ELI v5.0 (30deg probe tilt); Type: QDOVA002AA; Serial: TP:xxxx
- ; SEMCAD X Version 14.6.10 (7331)

Configuration/Right of EUT Facing Phantom - Middle 2 2/Area Scan (81x191x1): Interpolated grid: $dx=1.000 \text{ mm}$, $dy=1.000 \text{ mm}$

Maximum value of SAR (interpolated) = 1.58 W/kg

Configuration/Right of EUT Facing Phantom - Middle 2 2/Zoom Scan (7x7x12) 2 (7x7x12)/Cube 0: Measurement grid: $dx=4\text{mm}$, $dy=4\text{mm}$, $dz=2\text{mm}$

Reference Value = 15.18 V/m; Power Drift = -0.19 dB

Peak SAR (extrapolated) = 3.96 W/kg

SAR(1 g) = 1.22 W/kg; SAR(10 g) = 0.321 W/kg

Maximum value of SAR (measured) = 1.66 W/kg

160: Right of EUT Facing Phantom Wi-Fi 5GHz 802.11a CDD 6Mbps MIMO 2AB-A CH48

Date: 21/04/15

DUT: Inari 8; Type: Tablet

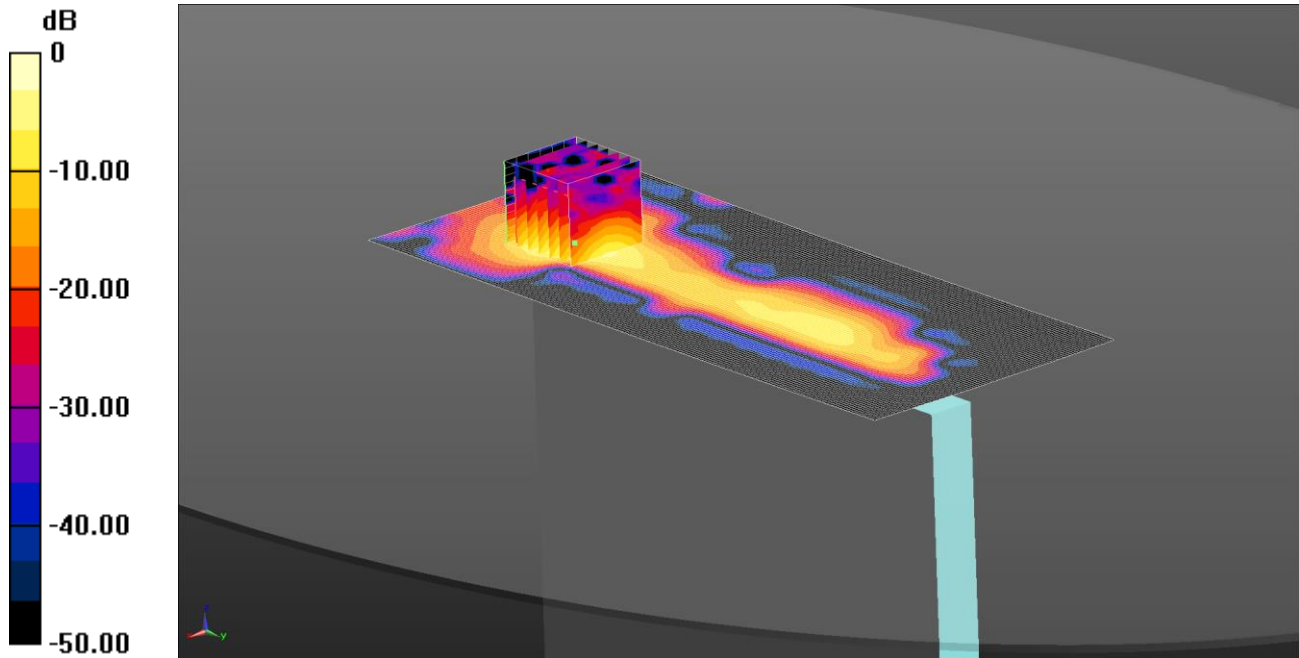

0 dB = 1.80 W/kg = 2.55 dBW/kg

Communication System: UID 0, WLAN 802.11 (0); Frequency: 5240 MHz; Duty Cycle: 1:1

Medium: 5GHz MSL Medium parameters used (interpolated): $f = 5240$ MHz; $\sigma = 5.322$ S/m; $\epsilon_r = 47.143$; $\rho = 1000$ kg/m³

Phantom section: Flat Section

DASY4 Configuration:

- Probe: EX3DV4 - SN3814; ConvF(4.38, 4.38, 4.38); Calibrated: 18/09/14;
- Sensor-Surface: 4mm (Mechanical Surface Detection)
- Electronics: DAE4 Sn1435; Calibrated: 20/02/15
- Phantom: ELI v5.0 (30deg probe tilt); Type: QDOVA002AA; Serial: TP:xxxx
- ; SEMCAD X Version 14.6.10 (7331)

Configuration/Right of EUT Facing Phantom - Middle 2 2/Area Scan (81x191x1): Interpolated grid: dx=1.000 mm, dy=1.000 mm

Maximum value of SAR (interpolated) = 1.79 W/kg

Configuration/Right of EUT Facing Phantom - Middle 2 2/Zoom Scan (7x7x12) 2 (7x7x12)/Cube 0: Measurement grid: dx=4mm, dy=4mm, dz=2mm

Reference Value = 16.73 V/m; Power Drift = -0.19 dB

Peak SAR (extrapolated) = 4.29 W/kg

SAR(1 g) = 1.35 W/kg; SAR(10 g) = 0.351 W/kg

Maximum value of SAR (measured) = 1.80 W/kg

161: Right of EUT Facing Phantom Wi-Fi 5GHz 802.11a 6Mbps SISO 2A CH52

Date: 23/04/15

DUT: Inari 8; Type: Tablet

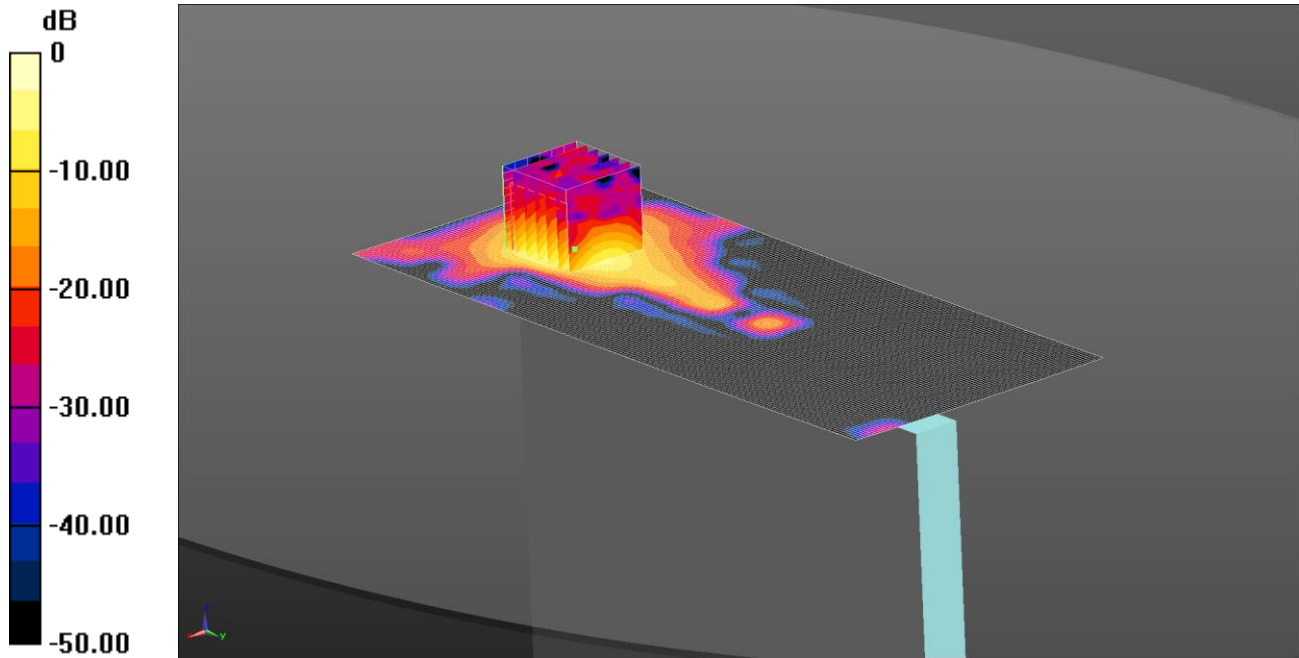

0 dB = 1.83 W/kg = 2.62 dBW/kg

Communication System: UID 0, WLAN 802.11 (0); Frequency: 5260 MHz; Duty Cycle: 1:1

Medium: 5GHz MSL Medium parameters used (interpolated): $f = 5260$ MHz; $\sigma = 5.36$ S/m; $\epsilon_r = 47.101$; $\rho = 1000$ kg/m³

Phantom section: Flat Section

DASY4 Configuration:

- Probe: EX3DV4 - SN3814; ConvF(4.18, 4.18, 4.18); Calibrated: 18/09/14;
- Sensor-Surface: 4mm (Mechanical Surface Detection)
- Electronics: DAE4 Sn1435; Calibrated: 20/02/15
- Phantom: ELI v5.0 (30deg probe tilt); Type: QDOVA002AA; Serial: TP:xxxx
- ; SEMCAD X Version 14.6.10 (7331)

Configuration/Right of EUT Facing Phantom - Middle 2 2/Area Scan (81x191x1): Interpolated grid: dx=1.000 mm, dy=1.000 mm

Maximum value of SAR (interpolated) = 1.86 W/kg

Configuration/Right of EUT Facing Phantom - Middle 2 2/Zoom Scan (7x7x12) 2 (7x7x12)/Cube 0: Measurement grid: dx=4mm, dy=4mm, dz=2mm

Reference Value = 17.68 V/m; Power Drift = 0.20 dB

Peak SAR (extrapolated) = 4.28 W/kg

SAR(1 g) = 1.38 W/kg; SAR(10 g) = 0.369 W/kg

Maximum value of SAR (measured) = 1.83 W/kg

162: Right of EUT Facing Phantom Wi-Fi 5GHz 802.11a 6Mbps SISO 2A CH64

Date: 22/04/15

DUT: Inari 8; Type: Tablet

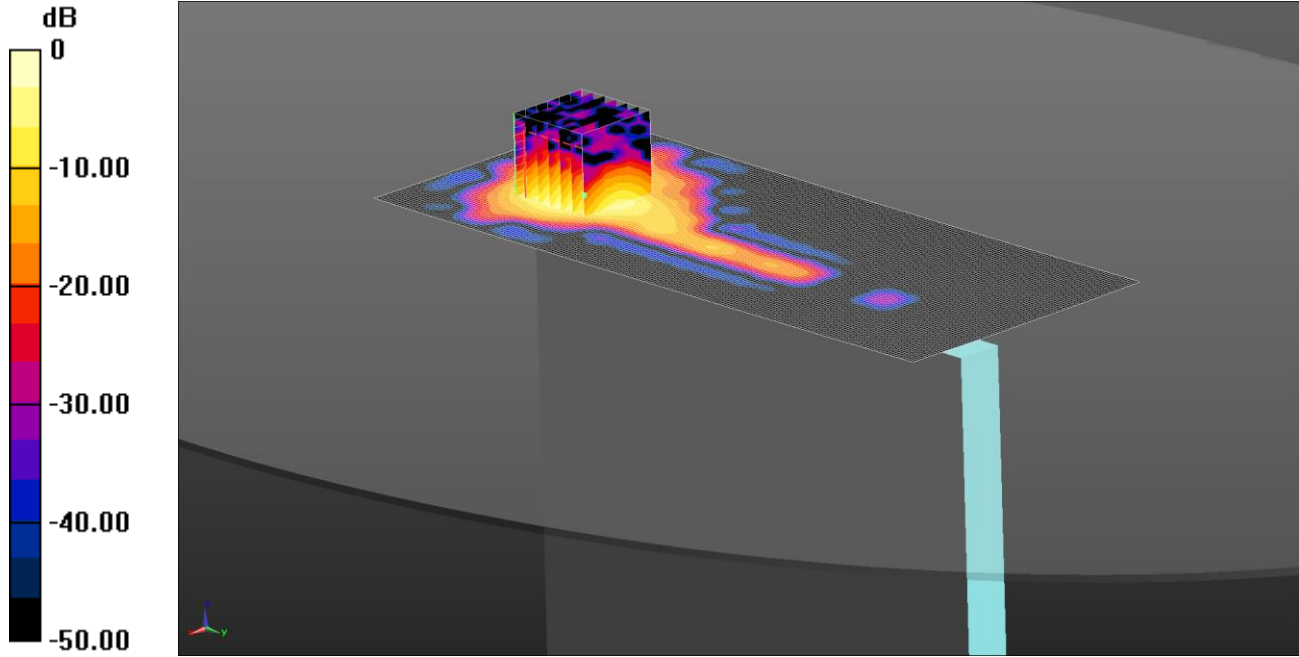

0 dB = 1.58 W/kg = 1.99 dBW/kg

Communication System: UID 0, WLAN 802.11 (0); Frequency: 5320 MHz; Duty Cycle: 1:1

Medium: 5GHz MSL Medium parameters used (interpolated): $f = 5320$ MHz; $\sigma = 5.457$ S/m; $\epsilon_r = 46.985$; $\rho = 1000$ kg/m³

Phantom section: Flat Section

DASY4 Configuration:

- Probe: EX3DV4 - SN3814; ConvF(4.18, 4.18, 4.18); Calibrated: 18/09/14;
- Sensor-Surface: 4mm (Mechanical Surface Detection)
- Electronics: DAE4 Sn1435; Calibrated: 20/02/15
- Phantom: ELI v5.0 (30deg probe tilt); Type: QDOVA002AA; Serial: TP:xxxx
- ; SEMCAD X Version 14.6.10 (7331)

Configuration/Right of EUT Facing Phantom - Middle 2 2/Area Scan (81x191x1): Interpolated grid: dx=1.000 mm, dy=1.000 mm

Maximum value of SAR (interpolated) = 1.52 W/kg

Configuration/Right of EUT Facing Phantom - Middle 2 2/Zoom Scan (7x7x12) 2 (7x7x12)/Cube 0: Measurement grid: dx=4mm, dy=4mm, dz=2mm

Reference Value = 15.64 V/m; Power Drift = -0.19 dB

Peak SAR (extrapolated) = 3.69 W/kg

SAR(1 g) = 1.2 W/kg; SAR(10 g) = 0.335 W/kg

Maximum value of SAR (measured) = 1.58 W/kg

163: Right of EUT Facing Phantom Wi-Fi 5GHz 802.11a 6Mbps SISO 2B CH64

Date: 22/04/15

DUT: Inari 8; Type: Tablet

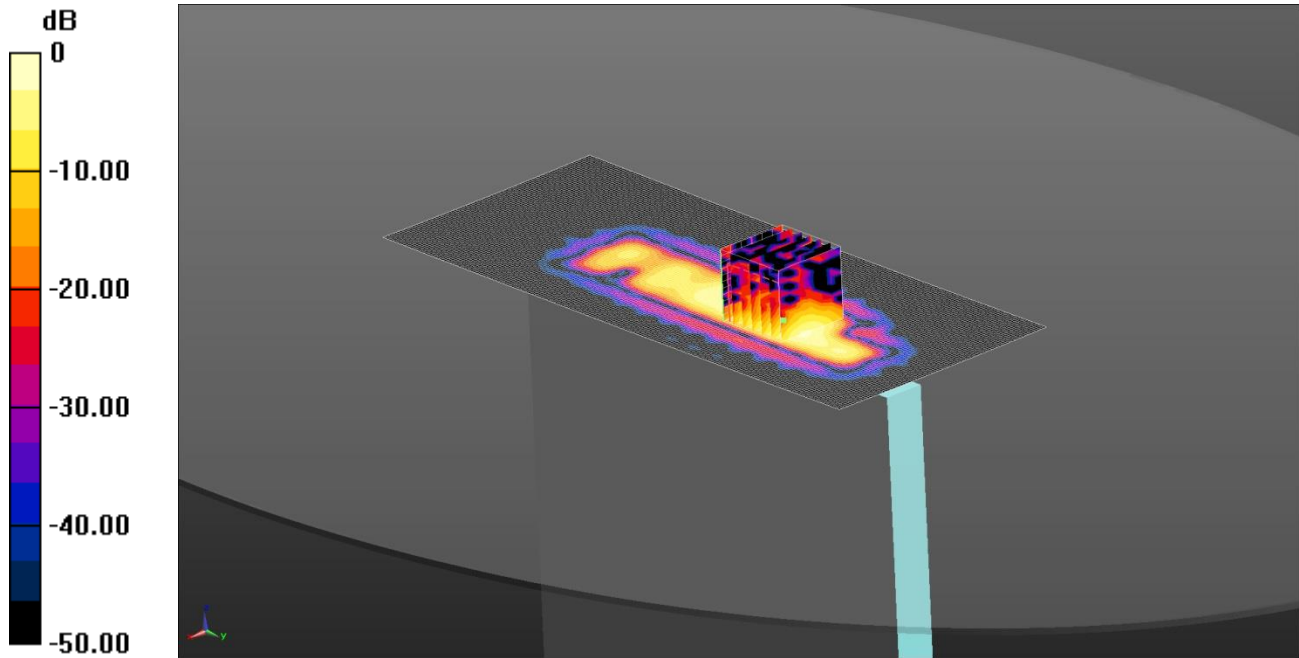

0 dB = 0.377 W/kg = -4.24 dBW/kg

Communication System: UID 0, WLAN 802.11 (0); Frequency: 5320 MHz; Duty Cycle: 1:1

Medium: 5GHz MSL Medium parameters used (interpolated): $f = 5320$ MHz; $\sigma = 5.457$ S/m; $\epsilon_r = 46.985$; $\rho = 1000$ kg/m³

Phantom section: Flat Section

DASY4 Configuration:

- Probe: EX3DV4 - SN3814; ConvF(4.18, 4.18, 4.18); Calibrated: 18/09/14;
- Sensor-Surface: 4mm (Mechanical Surface Detection)
- Electronics: DAE4 Sn1435; Calibrated: 20/02/15
- Phantom: ELI v5.0 (30deg probe tilt); Type: QDOVA002AA; Serial: TP:xxxx
- ; SEMCAD X Version 14.6.10 (7331)

Configuration/Right of EUT Facing Phantom - Middle 2 2/Area Scan (81x191x1): Interpolated grid: dx=1.000 mm, dy=1.000 mm

Maximum value of SAR (interpolated) = 0.268 W/kg

Configuration/Right of EUT Facing Phantom - Middle 2 2/Zoom Scan (7x7x12) 2 (7x7x12)/Cube 0: Measurement grid:

dx=4mm, dy=4mm, dz=2mm

Reference Value = 6.279 V/m; Power Drift = -0.12 dB

Peak SAR (extrapolated) = 0.958 W/kg

SAR(1 g) = 0.272 W/kg; SAR(10 g) = 0.073 W/kg

Maximum value of SAR (measured) = 0.377 W/kg

164: Right of EUT Facing Phantom Wi-Fi 5GHz 802.11a CDD 6Mbps MIMO 2AB-A CH52

Date: 22/04/15

DUT: Inari 8; Type: Tablet

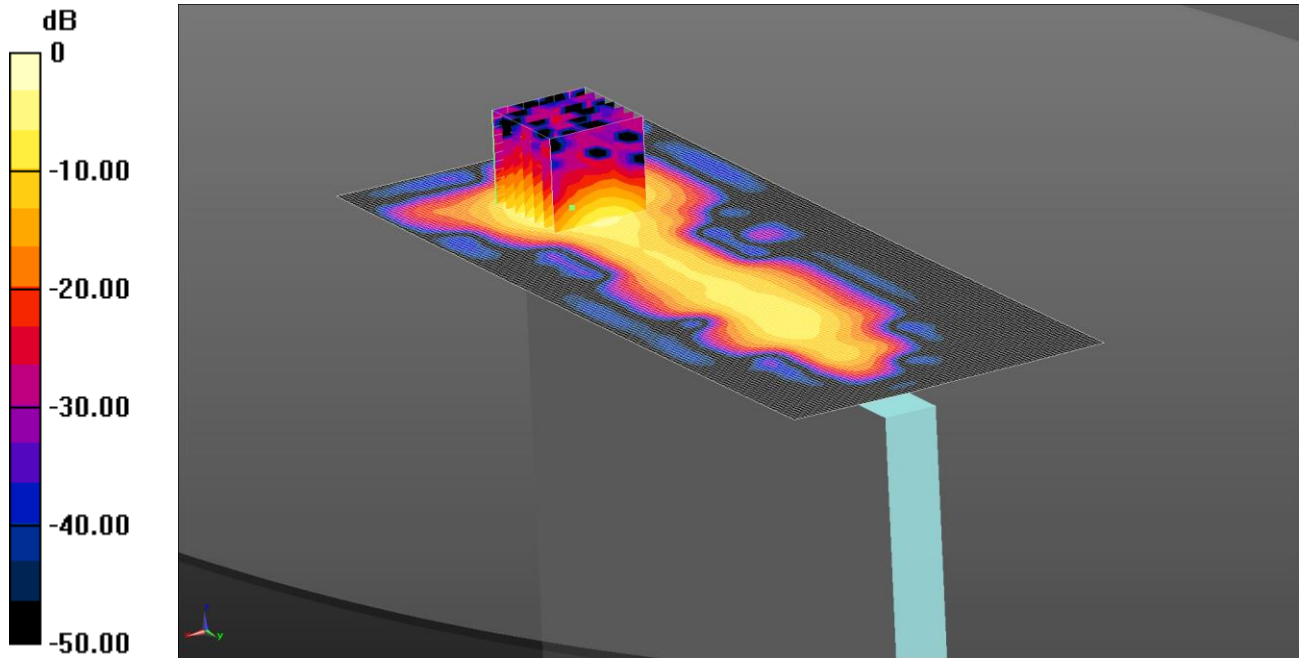

0 dB = 1.73 W/kg = 2.38 dBW/kg

Communication System: UID 0, WLAN 802.11 (0); Frequency: 5260 MHz; Duty Cycle: 1:1

Medium: 5GHz MSL Medium parameters used (interpolated): $f = 5260$ MHz; $\sigma = 5.36$ S/m; $\epsilon_r = 47.101$; $\rho = 1000$ kg/m³

Phantom section: Flat Section

DASY4 Configuration:

- Probe: EX3DV4 - SN3814; ConvF(4.18, 4.18, 4.18); Calibrated: 18/09/14;
- Sensor-Surface: 4mm (Mechanical Surface Detection)
- Electronics: DAE4 Sn1435; Calibrated: 20/02/15
- Phantom: ELI v5.0 (30deg probe tilt); Type: QDOVA002AA; Serial: TP:xxxx
- ; SEMCAD X Version 14.6.10 (7331)

Configuration/Right of EUT Facing Phantom - Middle 2 2/Area Scan (81x191x1): Interpolated grid: dx=1.000 mm, dy=1.000 mm

Maximum value of SAR (interpolated) = 1.78 W/kg

Configuration/Right of EUT Facing Phantom - Middle 2 2/Zoom Scan (7x7x12) 2 (7x7x12)/Cube 0: Measurement grid: dx=4mm, dy=4mm, dz=2mm

Reference Value = 17.76 V/m; Power Drift = -0.11 dB

Peak SAR (extrapolated) = 4.20 W/kg

SAR(1 g) = 1.31 W/kg; SAR(10 g) = 0.348 W/kg

Maximum value of SAR (measured) = 1.73 W/kg

165: Right of EUT Facing Phantom Wi-Fi 5GHz 802.11a CDD 6Mbps MIMO 2AB-A CH64
 Date: 22/04/15

DUT: Inari 8; Type: Tablet

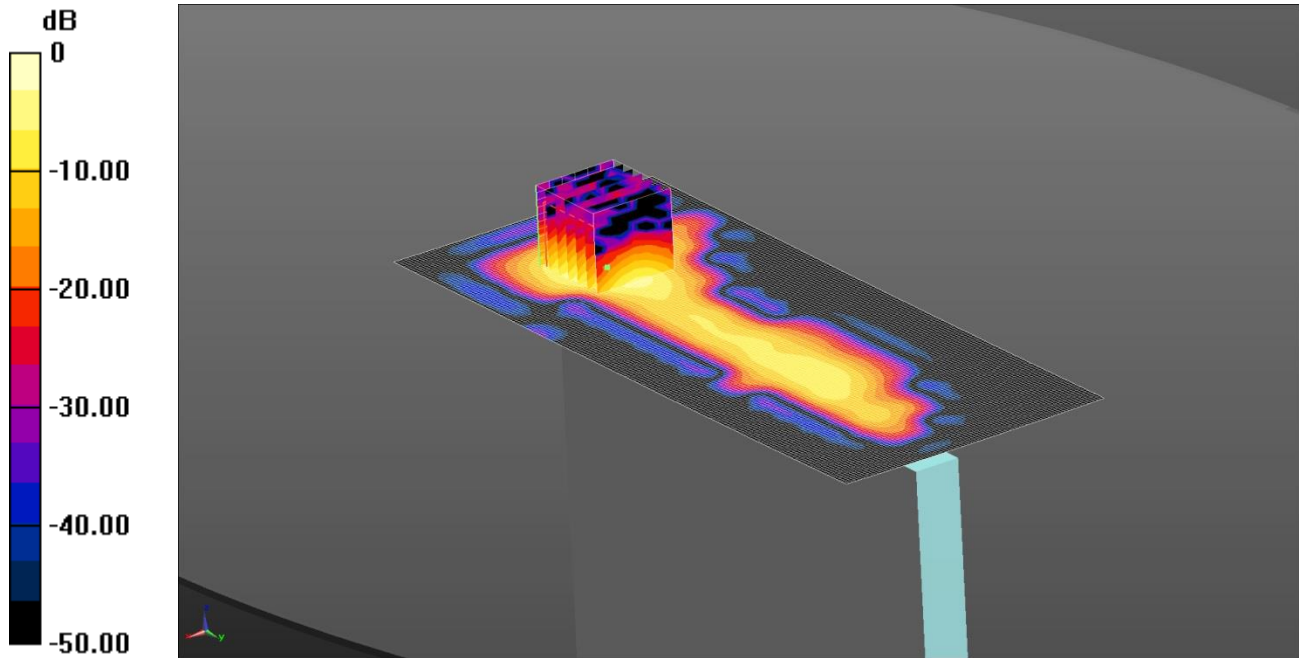

0 dB = 1.63 W/kg = 2.12 dBW/kg

Communication System: UID 0, WLAN 802.11 (0); Frequency: 5320 MHz; Duty Cycle: 1:1
 Medium: 5GHz MSL Medium parameters used (interpolated): $f = 5320$ MHz; $\sigma = 5.457$ S/m; $\epsilon_r = 46.985$; $\rho = 1000$ kg/m³
 Phantom section: Flat Section
 DASY4 Configuration:
 - Probe: EX3DV4 - SN3814; ConvF(4.18, 4.18, 4.18); Calibrated: 18/09/14;
 - Sensor-Surface: 4mm (Mechanical Surface Detection)
 - Electronics: DAE4 Sn1435; Calibrated: 20/02/15
 - Phantom: ELI v5.0 (30deg probe tilt); Type: QDOVA002AA; Serial: TP:xxxx
 - ; SEMCAD X Version 14.6.10 (7331)

Configuration/Right of EUT Facing Phantom - Middle 2 2/Area Scan (81x191x1): Interpolated grid: dx=1.000 mm, dy=1.000 mm
 Maximum value of SAR (interpolated) = 1.56 W/kg

Configuration/Right of EUT Facing Phantom - Middle 2 2/Zoom Scan (7x7x12) 2 (7x7x12)/Cube 0: Measurement grid: dx=4mm, dy=4mm, dz=2mm
 Reference Value = 16.85 V/m; Power Drift = -0.19 dB
 Peak SAR (extrapolated) = 3.79 W/kg
SAR(1 g) = 1.22 W/kg; SAR(10 g) = 0.337 W/kg.
 Maximum value of SAR (measured) = 1.63 W/kg

166: Right of EUT Facing Phantom Wi-Fi 5GHz 802.11a 6Mbps SISO 2A CH104

Date: 22/04/15

DUT: Inari 8; Type: Tablet

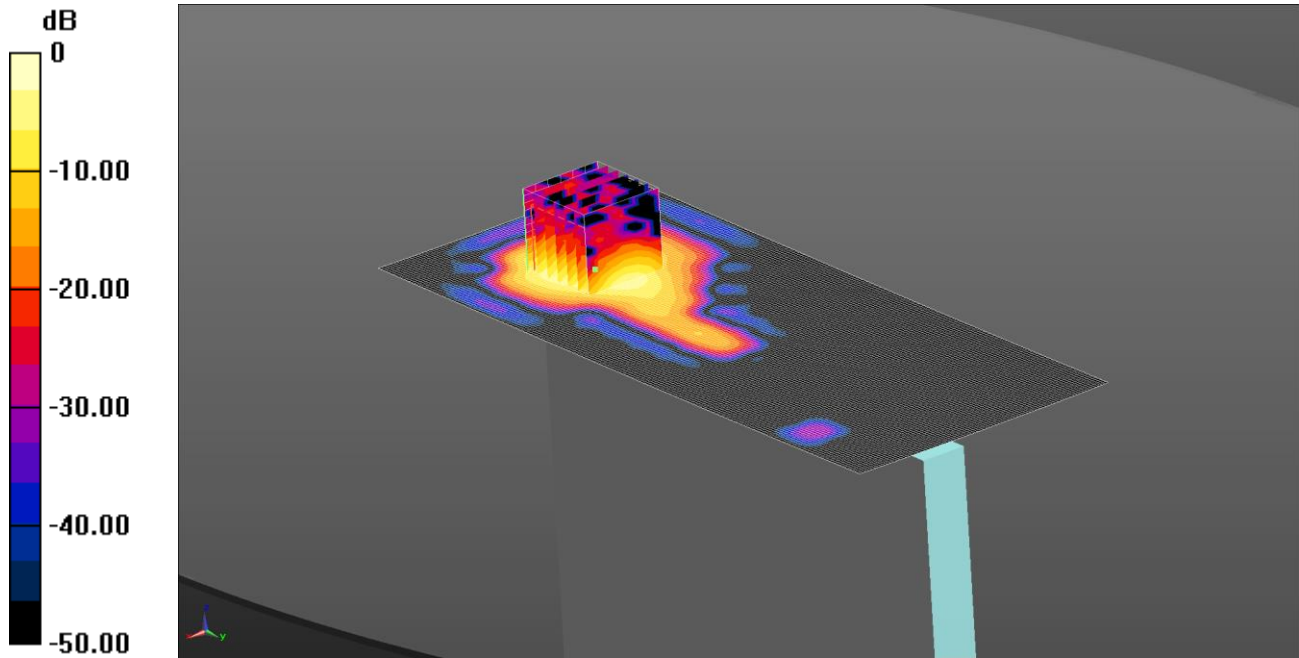

0 dB = 0.899 W/kg = -0.46 dBW/kg

Communication System: UID 0, WLAN 802.11 (0); Frequency: 5520 MHz; Duty Cycle: 1:1

Medium: 5GHz MSL Medium parameters used (interpolated): $f = 5520$ MHz; $\sigma = 5.79$ S/m; $\epsilon_r = 46.539$; $\rho = 1000$ kg/m³

Phantom section: Flat Section

DASY4 Configuration:

- Probe: EX3DV4 - SN3814; ConvF(3.97, 3.97, 3.97); Calibrated: 18/09/14;
- Sensor-Surface: 4mm (Mechanical Surface Detection)
- Electronics: DAE4 Sn1435; Calibrated: 20/02/15
- Phantom: ELI v5.0 (30deg probe tilt); Type: QDOVA002AA; Serial: TP:xxxx
- ; SEMCAD X Version 14.6.10 (7331)

Configuration/Right of EUT Facing Phantom - Middle 2 2/Area Scan (81x191x1): Interpolated grid: dx=1.000 mm, dy=1.000 mm

Maximum value of SAR (interpolated) = 0.846 W/kg

Configuration/Right of EUT Facing Phantom - Middle 2 2/Zoom Scan (7x7x12) 2 (7x7x12)/Cube 0: Measurement grid:

dx=4mm, dy=4mm, dz=2mm

Reference Value = 12.36 V/m; Power Drift = -0.11 dB

Peak SAR (extrapolated) = 2.31 W/kg

SAR(1 g) = 0.700 W/kg; SAR(10 g) = 0.202 W/kg

Maximum value of SAR (measured) = 0.899 W/kg

167: Right of EUT Facing Phantom Wi-Fi 5GHz 802.11a 6Mbps SISO 2A CH116

Date: 22/04/15

DUT: Inari 8; Type: Tablet

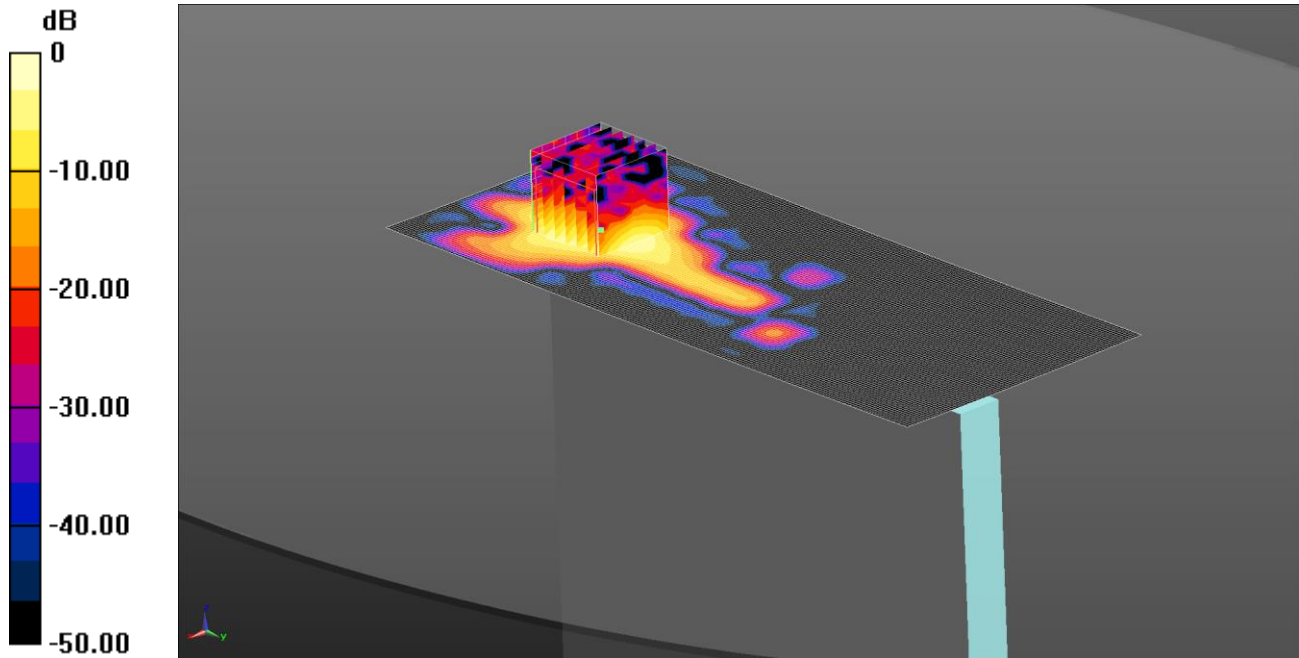

0 dB = 0.752 W/kg = -1.24 dBW/kg

Communication System: UID 0, WLAN 802.11 (0); Frequency: 5580 MHz; Duty Cycle: 1:1

Medium: 5GHz MSL Medium parameters used (interpolated): $f = 5580$ MHz; $\sigma = 5.898$ S/m; $\epsilon_r = 46.397$; $\rho = 1000$ kg/m³

Phantom section: Flat Section

DASY4 Configuration:

- Probe: EX3DV4 - SN3814; ConvF(3.79, 3.79, 3.79); Calibrated: 18/09/14;
- Sensor-Surface: 4mm (Mechanical Surface Detection)
- Electronics: DAE4 Sn1435; Calibrated: 20/02/15
- Phantom: ELI v5.0 (30deg probe tilt); Type: QDOVA002AA; Serial: TP:xxxx
- ; SEMCAD X Version 14.6.10 (7331)

Configuration/Right of EUT Facing Phantom - Middle 2 2/Area Scan (81x191x1): Interpolated grid: dx=1.000 mm, dy=1.000 mm

Maximum value of SAR (interpolated) = 0.712 W/kg

Configuration/Right of EUT Facing Phantom - Middle 2 2/Zoom Scan (7x7x12) 2 (7x7x12)/Cube 0: Measurement grid:

dx=4mm, dy=4mm, dz=2mm

Reference Value = 10.15 V/m; Power Drift = -0.14 dB

Peak SAR (extrapolated) = 2.21 W/kg

SAR(1 g) = 0.611 W/kg; SAR(10 g) = 0.175 W/kg

Maximum value of SAR (measured) = 0.752 W/kg

168: Right of EUT Facing Phantom Wi-Fi 5GHz 802.11a 6Mbps SISO 2A CH136

Date: 22/04/15

DUT: Inari 8; Type: Tablet

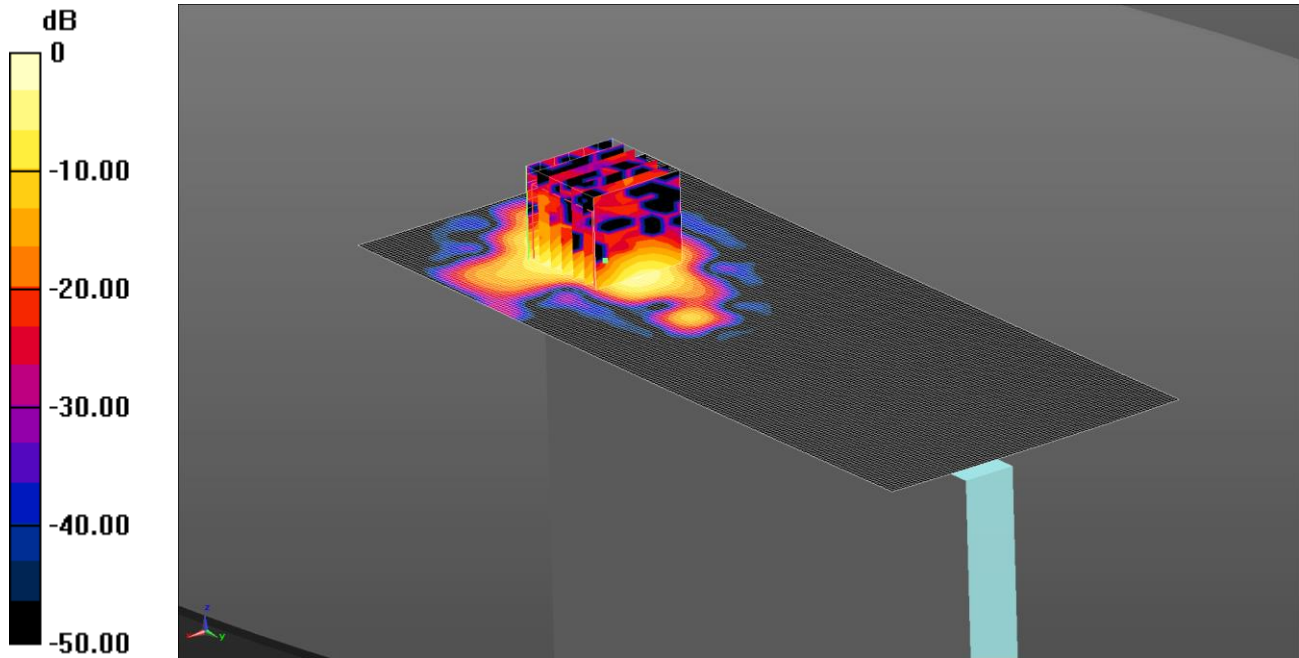

0 dB = 0.653 W/kg = -1.85 dBW/kg

Communication System: UID 0, WLAN 802.11 (0); Frequency: 5680 MHz; Duty Cycle: 1:1

Medium: 5GHz MSL Medium parameters used (interpolated): $f = 5680$ MHz; $\sigma = 6.053$ S/m; $\epsilon_r = 46.154$; $\rho = 1000$ kg/m³

Phantom section: Flat Section

DASY4 Configuration:

- Probe: EX3DV4 - SN3814;
- Sensor-Surface: 4mm (Mechanical Surface Detection)
- Electronics: DAE4 Sn1435; Calibrated: 20/02/15
- Phantom: ELI v5.0 (30deg probe tilt); Type: QDOVA002AA; Serial: TP:xxxx
- ; SEMCAD X Version 14.6.10 (7331)

Configuration/Right of EUT Facing Phantom - Middle 2 2/Area Scan (81x191x1): Interpolated grid: dx=1.000 mm, dy=1.000 mm

Maximum value of SAR (interpolated) = 0.676 W/kg

Configuration/Right of EUT Facing Phantom - Middle 2 2/Zoom Scan (7x7x12) 2 (7x7x12)/Cube 0: Measurement grid: dx=4mm, dy=4mm, dz=2mm

Reference Value = 9.621 V/m; Power Drift = -0.13 dB

Peak SAR (extrapolated) = 2.08 W/kg

SAR(1 g) = 0.540 W/kg; SAR(10 g) = 0.147 W/kg

Maximum value of SAR (measured) = 0.653 W/kg

169: Right of EUT Facing Phantom Wi-Fi 5GHz 802.11a 6Mbps SISO 2B CH104

Date: 22/04/15

DUT: Inari 8; Type: Tablet

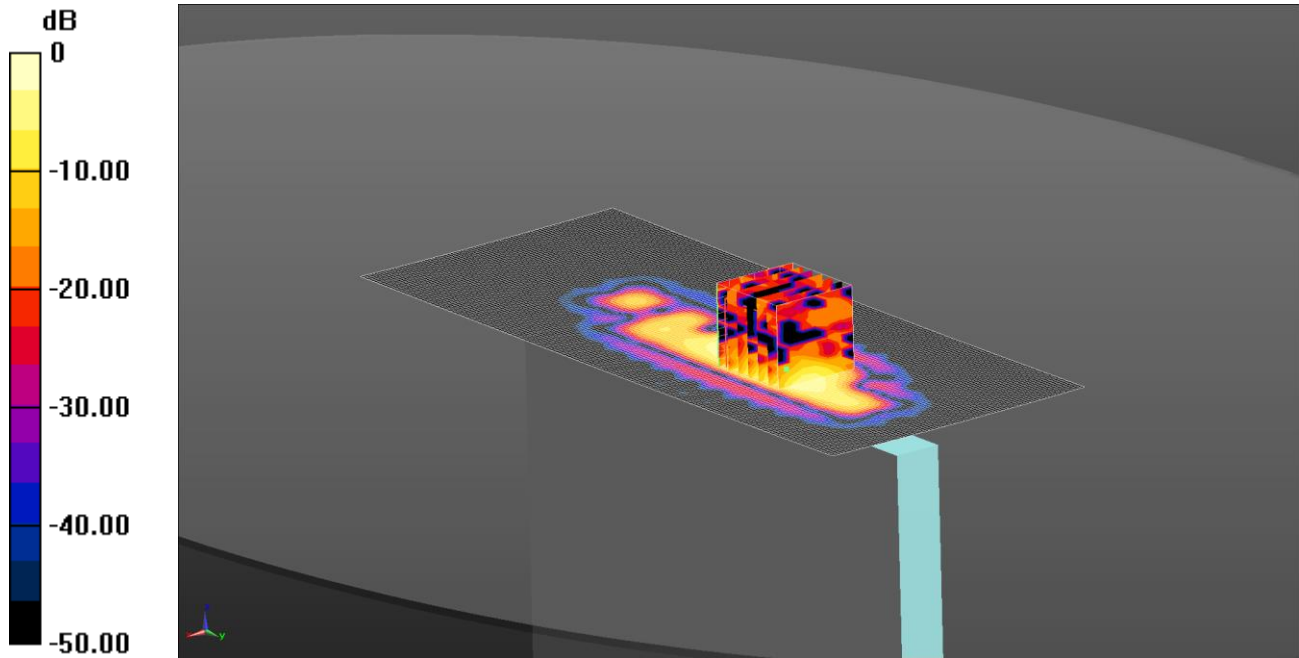

0 dB = 0.260 W/kg = -5.85 dBW/kg

Communication System: UID 0, WLAN 802.11 (0); Frequency: 5520 MHz; Duty Cycle: 1:1

Medium: 5GHz MSL Medium parameters used (interpolated): $f = 5520$ MHz; $\sigma = 5.79$ S/m; $\epsilon_r = 46.539$; $\rho = 1000$ kg/m³

Phantom section: Flat Section

DASY4 Configuration:

- Probe: EX3DV4 - SN3814; ConvF(3.97, 3.97, 3.97); Calibrated: 18/09/14;
- Sensor-Surface: 4mm (Mechanical Surface Detection)
- Electronics: DAE4 Sn1435; Calibrated: 20/02/15
- Phantom: ELI v5.0 (30deg probe tilt); Type: QDOVA002AA; Serial: TP:xxxx
- ; SEMCAD X Version 14.6.10 (7331)

Configuration/Right of EUT Facing Phantom - Middle 2 2/Area Scan (81x191x1): Interpolated grid: dx=1.000 mm, dy=1.000 mm

Maximum value of SAR (interpolated) = 0.193 W/kg

Configuration/Right of EUT Facing Phantom - Middle 2 2/Zoom Scan (7x7x12) 2 (7x7x12)/Cube 0: Measurement grid: dx=4mm, dy=4mm, dz=2mm

Reference Value = 4.545 V/m; Power Drift = -0.20 dB

Peak SAR (extrapolated) = 0.745 W/kg

SAR(1 g) = 0.193 W/kg; SAR(10 g) = 0.047 W/kg

Maximum value of SAR (measured) = 0.260 W/kg

170: Right of EUT Facing Phantom Wi-Fi 5GHz 802.11a CDD 6Mbps MIMO 2AB-A CH104

Date: 22/04/15

DUT: Inari 8; Type: Tablet

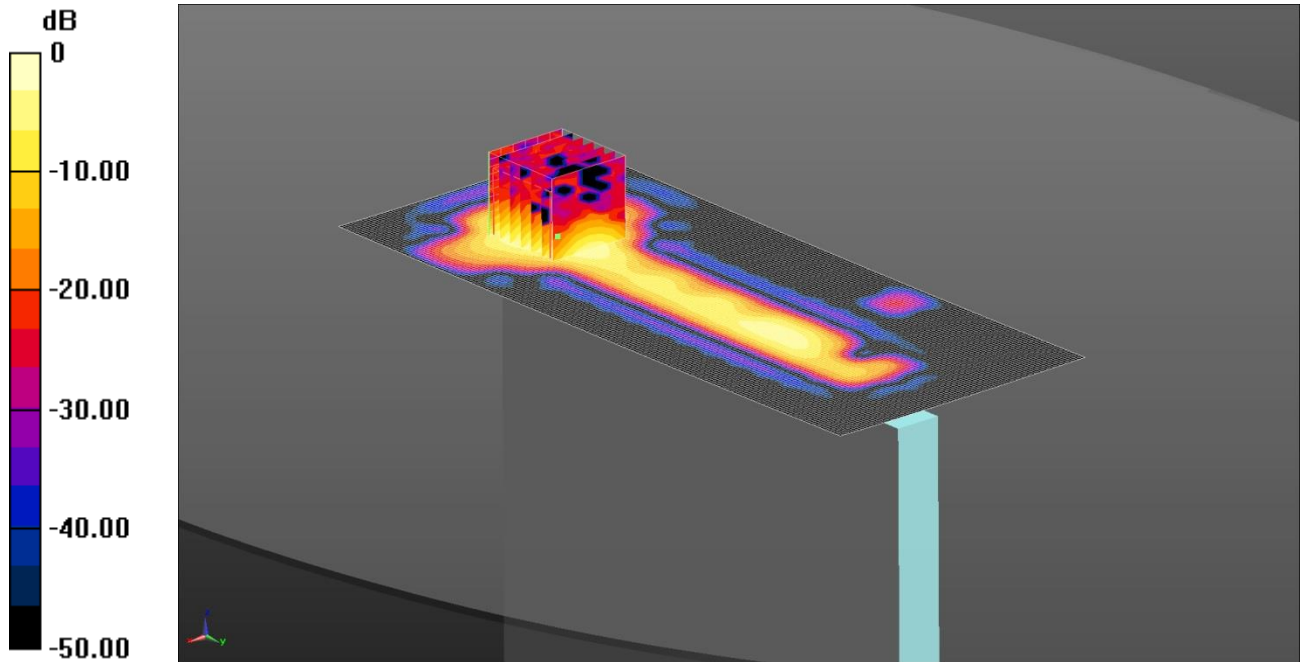

0 dB = 0.841 W/kg = -0.75 dBW/kg

Communication System: UID 0, WLAN 802.11 (0); Frequency: 5520 MHz; Duty Cycle: 1:1

Medium: 5GHz MSL Medium parameters used (interpolated): $f = 5520$ MHz; $\sigma = 5.79$ S/m; $\epsilon_r = 46.539$; $\rho = 1000$ kg/m³

Phantom section: Flat Section

DASY4 Configuration:

- Probe: EX3DV4 - SN3814; ConvF(3.97, 3.97, 3.97); Calibrated: 18/09/14;
- Sensor-Surface: 4mm (Mechanical Surface Detection)
- Electronics: DAE4 Sn1435; Calibrated: 20/02/15
- Phantom: ELI v5.0 (30deg probe tilt); Type: QDOVA002AA; Serial: TP:xxxx
- ; SEMCAD X Version 14.6.10 (7331)

Configuration/Right of EUT Facing Phantom - Middle 2 2/Area Scan (81x191x1): Interpolated grid: dx=1.000 mm, dy=1.000 mm

Maximum value of SAR (interpolated) = 0.814 W/kg

Configuration/Right of EUT Facing Phantom - Middle 2 2/Zoom Scan (7x7x12) 2 (7x7x12)/Cube 0: Measurement grid: dx=4mm, dy=4mm, dz=2mm

Reference Value = 11.38 V/m; Power Drift = -0.20 dB

Peak SAR (extrapolated) = 3.25 W/kg

SAR(1 g) = 0.656 W/kg; SAR(10 g) = 0.177 W/kg

Maximum value of SAR (measured) = 0.841 W/kg

171: Right of EUT Facing Phantom Wi-Fi 5GHz 802.11a CDD 6Mbps MIMO 2AB-A CH116

Date: 22/04/15

DUT: Inari 8; Type: Tablet

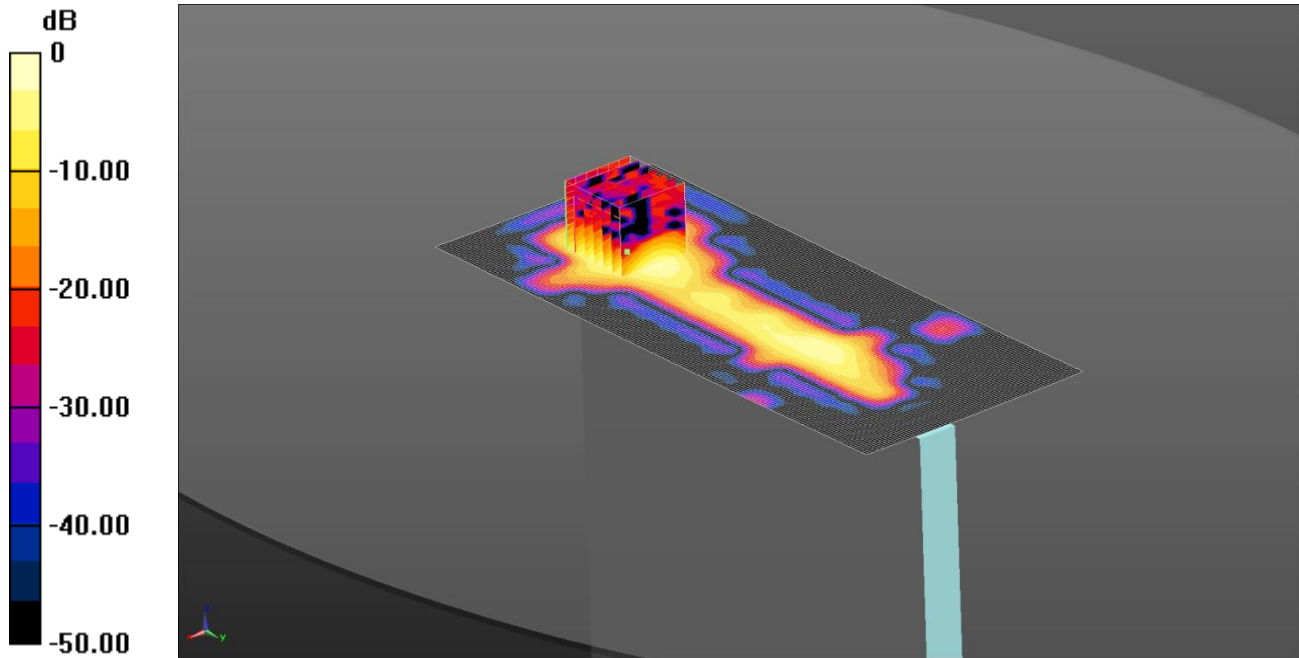

0 dB = 0.739 W/kg = -1.31 dBW/kg

Communication System: UID 0, WLAN 802.11 (0); Frequency: 5580 MHz; Duty Cycle: 1:1

Medium: 5GHz MSL Medium parameters used (interpolated): $f = 5580$ MHz; $\sigma = 5.898$ S/m; $\epsilon_r = 46.397$; $\rho = 1000$ kg/m³

Phantom section: Flat Section

DASY4 Configuration:

- Probe: EX3DV4 - SN3814; ConvF(3.79, 3.79, 3.79); Calibrated: 18/09/14;
- Sensor-Surface: 4mm (Mechanical Surface Detection)
- Electronics: DAE4 Sn1435; Calibrated: 20/02/15
- Phantom: ELI v5.0 (30deg probe tilt); Type: QDOVA002AA; Serial: TP:xxxx
- ; SEMCAD X Version 14.6.10 (7331)

Configuration/Right of EUT Facing Phantom - Middle 2 2/Area Scan (81x191x1): Interpolated grid: dx=1.000 mm, dy=1.000 mm

Maximum value of SAR (interpolated) = 0.742 W/kg

Configuration/Right of EUT Facing Phantom - Middle 2 2/Zoom Scan (7x7x12) 2 (7x7x12)/Cube 0: Measurement grid:

dx=4mm, dy=4mm, dz=2mm

Reference Value = 11.32 V/m; Power Drift = -0.05 dB

Peak SAR (extrapolated) = 2.17 W/kg

SAR(1 g) = 0.597 W/kg; SAR(10 g) = 0.171 W/kg

Maximum value of SAR (measured) = 0.739 W/kg

172: Right of EUT Facing Phantom Wi-Fi 5GHz 802.11a CDD 6Mbps MIMO 2AB-A CH136

Date: 23/04/15

DUT: Inari 8; Type: Tablet

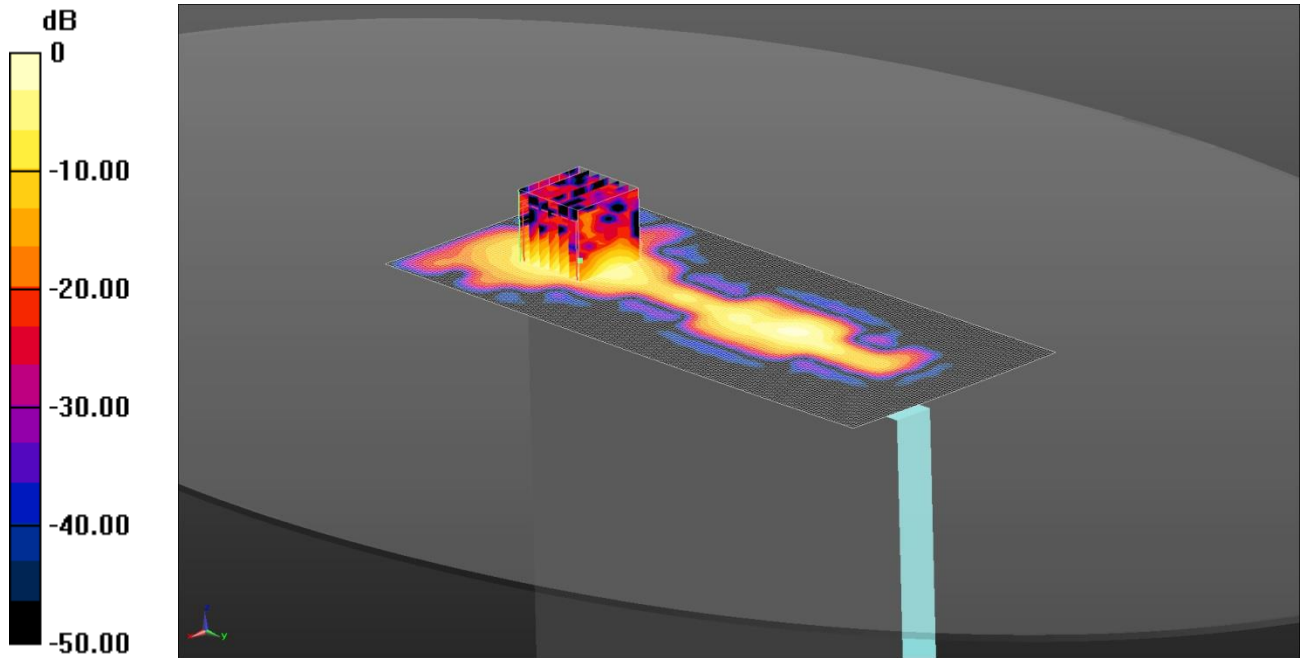

0 dB = 0.717 W/kg = -1.44 dBW/kg

Communication System: UID 0, WLAN 802.11 (0); Frequency: 5680 MHz; Duty Cycle: 1:1

Medium: 5GHz MSL Medium parameters used (interpolated): $f = 5680$ MHz; $\sigma = 6.053$ S/m; $\epsilon_r = 46.154$; $\rho = 1000$ kg/m³

Phantom section: Flat Section

DASY4 Configuration:

- Probe: EX3DV4 - SN3814;
- Sensor-Surface: 4mm (Mechanical Surface Detection)
- Electronics: DAE4 Sn1435; Calibrated: 20/02/15
- Phantom: ELI v5.0 (30deg probe tilt); Type: QDOVA002AA; Serial: TP:xxxx
- ; SEMCAD X Version 14.6.10 (7331)

Configuration/Right of EUT Facing Phantom - Middle 2 2/Area Scan (81x191x1): Interpolated grid: dx=1.000 mm, dy=1.000 mm

Maximum value of SAR (interpolated) = 0.742 W/kg

Configuration/Right of EUT Facing Phantom - Middle 2 2/Zoom Scan (7x7x12) 2 (7x7x12)/Cube 0: Measurement grid:

dx=4mm, dy=4mm, dz=2mm

Reference Value = 11.10 V/m; Power Drift = 0.08 dB

Peak SAR (extrapolated) = 2.11 W/kg

SAR(1 g) = 0.574 W/kg; SAR(10 g) = 0.160 W/kg

Maximum value of SAR (measured) = 0.717 W/kg

173: Right of EUT Facing Phantom Wi-Fi 5GHz 802.11a 6Mbps SISO 2A CH165

Date: 23/04/15

DUT: Inari 8; Type: Tablet

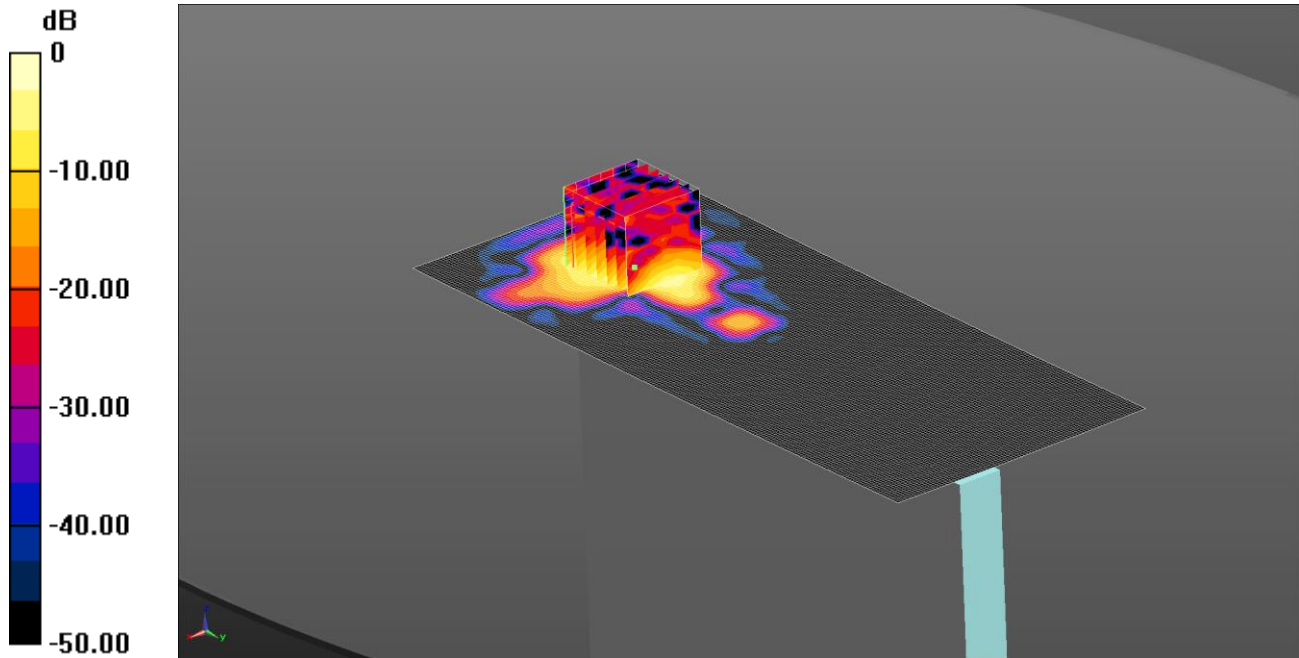

0 dB = 0.726 W/kg = -1.39 dBW/kg

Communication System: UID 0, WLAN 802.11 (0); Frequency: 5825 MHz; Duty Cycle: 1:1

Medium: 5GHz MSL Medium parameters used (interpolated): $f = 5825$ MHz; $\sigma = 6.282$ S/m; $\epsilon_r = 45.807$; $\rho = 1000$ kg/m³

Phantom section: Flat Section

DASY4 Configuration:

- Probe: EX3DV4 - SN3814; ConvF(4.06, 4.06, 4.06); Calibrated: 18/09/14;
- Sensor-Surface: 4mm (Mechanical Surface Detection)
- Electronics: DAE4 Sn1435; Calibrated: 20/02/15
- Phantom: ELI v5.0 (30deg probe tilt); Type: QDOVA002AA; Serial: TP:xxxx
- ; SEMCAD X Version 14.6.10 (7331)

Configuration/Right of EUT Facing Phantom - Middle 2 2/Area Scan (81x191x1): Interpolated grid: dx=1.000 mm, dy=1.000 mm

Maximum value of SAR (interpolated) = 0.809 W/kg

Configuration/Right of EUT Facing Phantom - Middle 2 2/Zoom Scan (7x7x12) 2 (7x7x12)/Cube 0: Measurement grid:

dx=4mm, dy=4mm, dz=2mm

Reference Value = 10.90 V/m; Power Drift = 0.09 dB

Peak SAR (extrapolated) = 2.39 W/kg

SAR(1 g) = 0.575 W/kg; SAR(10 g) = 0.142 W/kg

Maximum value of SAR (measured) = 0.726 W/kg

174: Right of EUT Facing Phantom Wi-Fi 5GHz 802.11a 6Mbps SISO 2B CH149

Date: 23/04/15

DUT: Inari 8; Type: Tablet

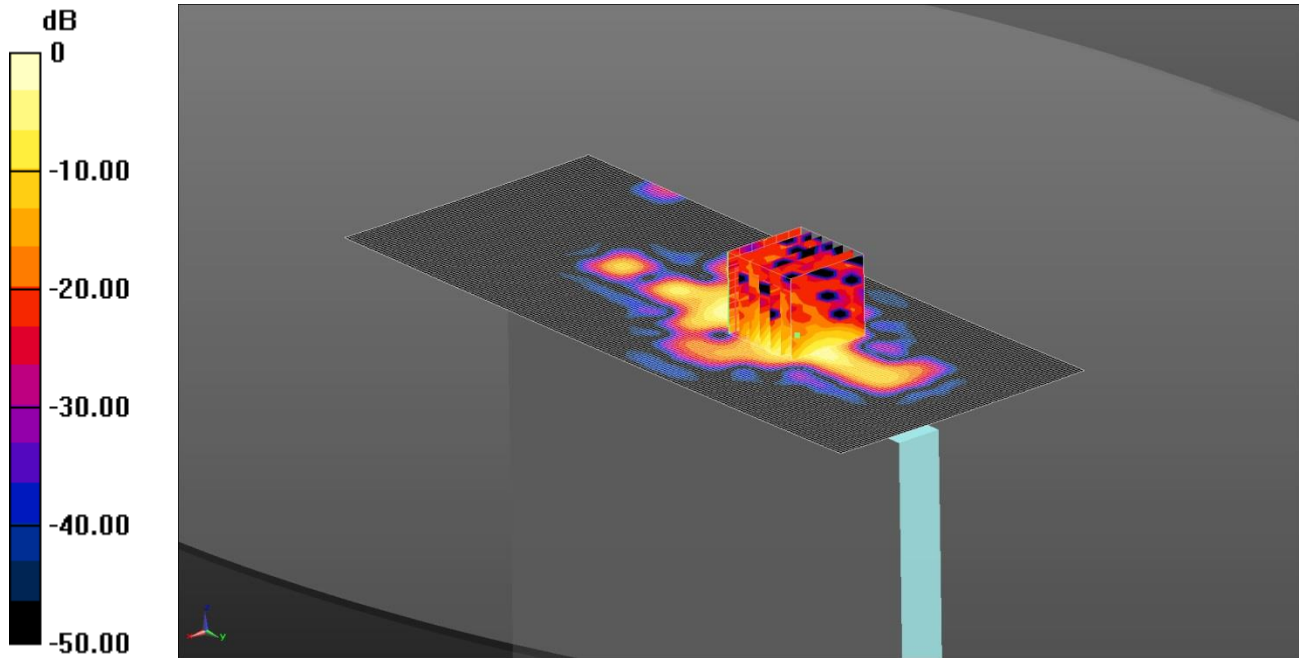

0 dB = 0.491 W/kg = -3.09 dBW/kg

Communication System: UID 0, WLAN 802.11 (0); Frequency: 5745 MHz; Duty Cycle: 1:1

Medium: 5GHz MSL Medium parameters used (interpolated): $f = 5745$ MHz; $\sigma = 6.166$ S/m; $\epsilon_r = 45.972$; $\rho = 1000$ kg/m³

Phantom section: Flat Section

DASY4 Configuration:

- Probe: EX3DV4 - SN3814; ConvF(4.06, 4.06, 4.06); Calibrated: 18/09/14;
- Sensor-Surface: 4mm (Mechanical Surface Detection)
- Electronics: DAE4 Sn1435; Calibrated: 20/02/15
- Phantom: ELI v5.0 (30deg probe tilt); Type: QDOVA002AA; Serial: TP:xxxx
- ; SEMCAD X Version 14.6.10 (7331)

Configuration/Right of EUT Facing Phantom - Middle 2 2/Area Scan (81x191x1): Interpolated grid: dx=1.000 mm, dy=1.000 mm

Maximum value of SAR (interpolated) = 0.624 W/kg

Configuration/Right of EUT Facing Phantom - Middle 2 2/Zoom Scan (7x7x12) 2 (7x7x12)/Cube 0: Measurement grid:

dx=4mm, dy=4mm, dz=2mm

Reference Value = 7.064 V/m; Power Drift = -0.11 dB

Peak SAR (extrapolated) = 1.50 W/kg

SAR(1 g) = 0.387 W/kg; SAR(10 g) = 0.090 W/kg

Maximum value of SAR (measured) = 0.491 W/kg

175: Right of EUT Facing Phantom Wi-Fi 5GHz 802.11a CDD 6Mbps MIMO 2AB-BA CH165

Date: 23/04/15

DUT: Inari 8; Type: Tablet

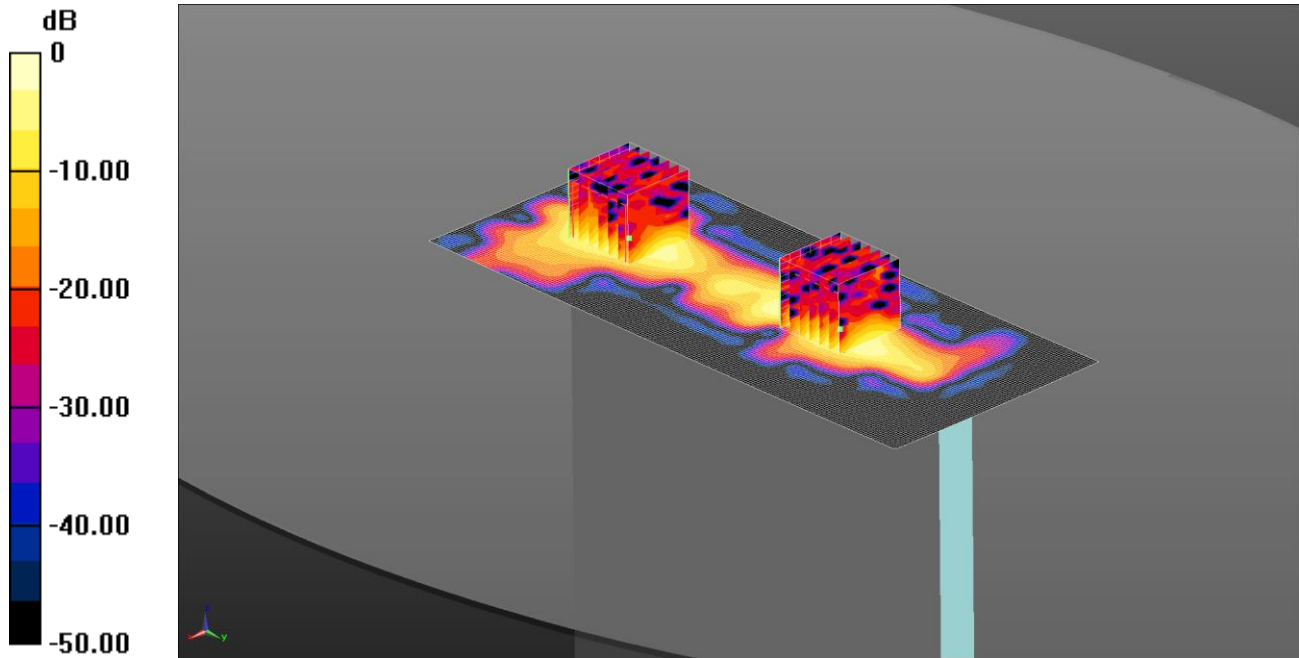

0 dB = 0.716 W/kg = -1.45 dBW/kg

Communication System: UID 0, WLAN 802.11 (0); Frequency: 5825 MHz; Duty Cycle: 1:1

Medium: 5GHz MSL Medium parameters used (interpolated): $f = 5825$ MHz; $\sigma = 6.282$ S/m; $\epsilon_r = 45.807$; $\rho = 1000$ kg/m³

Phantom section: Flat Section

DASY4 Configuration:

- Probe: EX3DV4 - SN3814; ConvF(4.06, 4.06, 4.06); Calibrated: 18/09/14;
- Sensor-Surface: 4mm (Mechanical Surface Detection)
- Electronics: DAE4 Sn1435; Calibrated: 20/02/15
- Phantom: ELI v5.0 (30deg probe tilt); Type: QDOVA002AA; Serial: TP:xxxx
- ; SEMCAD X Version 14.6.10 (7331)

Configuration/Right of EUT Facing Phantom - Middle 2 2/Area Scan (81x191x1): Interpolated grid: dx=1.000 mm, dy=1.000 mm

Maximum value of SAR (interpolated) = 0.776 W/kg

Configuration/Right of EUT Facing Phantom - Middle 2 2/Zoom Scan (7x7x12) 2 (7x7x12)/Cube 0: Measurement grid: dx=4mm, dy=4mm, dz=2mm

Reference Value = 10.57 V/m; Power Drift = 0.19 dB

Peak SAR (extrapolated) = 2.05 W/kg

SAR(1 g) = 0.526 W/kg; SAR(10 g) = 0.130 W/kg

Maximum value of SAR (measured) = 0.661 W/kg

Configuration/Right of EUT Facing Phantom - Middle 2 2/Zoom Scan (7x7x12) 2 (7x7x12)/Cube 1: Measurement grid: dx=4mm, dy=4mm, dz=2mm

Reference Value = 10.57 V/m; Power Drift = 0.19 dB

Peak SAR (extrapolated) = 2.14 W/kg

SAR(1 g) = 0.574 W/kg; SAR(10 g) = 0.151 W/kg

Maximum value of SAR (measured) = 0.716 W/kg

Note: DASY system is configured to measure any secondary maxima that are within 2dB of the measured SAR level.

176: Back of EUT Facing Phantom Bluetooth CH39

Date: 17/04/2015

DUT: Inari 8; Type: Tablet

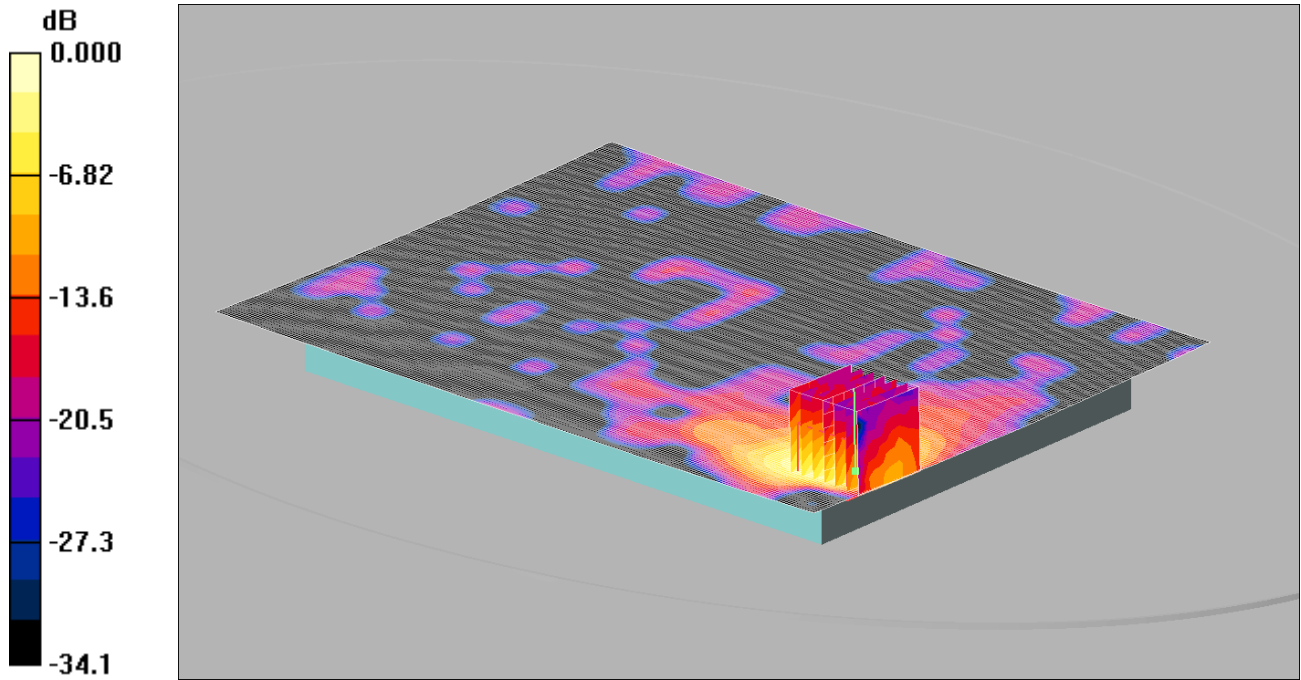

0 dB = 0.064mW/g

Communication System: Bluetooth; Frequency: 2441 MHz; Duty Cycle: 1:3.22

Medium: 2450 MHz MSL Medium parameters used (interpolated): $f = 2441 \text{ MHz}$; $\sigma = 1.91 \text{ mho/m}$; $\epsilon_r = 51.3$; $\rho = 1000 \text{ kg/m}^3$

Phantom section: Flat Section

DASY4 Configuration:

- Probe: ES3DV3 - SN3304; ConvF(4.24, 4.24, 4.24);
- Sensor-Surface: 4mm (Mechanical Surface Detection)
- Electronics: DAE3 Sn432; Calibrated: 20/08/2014
- Phantom: ELI v5.0; Type: QDOVA002AA; Serial: TP:xxxx
- Measurement SW: DASY4, V4.7 Build 80; Postprocessing SW: SEMCAD, V1.8 Build 186

Back - Middle/Area Scan (161x221x1): Measurement grid: $dx=12\text{mm}$, $dy=12\text{mm}$
 Maximum value of SAR (interpolated) = 0.073 mW/g

Back - Middle/Zoom Scan (7x7x7) (7x7x7)/Cube 0: Measurement grid: $dx=5\text{mm}$, $dy=5\text{mm}$, $dz=5\text{mm}$

Reference Value = 2.43 V/m; Power Drift = 0.114 dB

Peak SAR (extrapolated) = 0.140 W/kg

SAR(1 g) = 0.053 mW/g; SAR(10 g) = 0.022 mW/g

Maximum value of SAR (measured) = 0.064 mW/g

177: Right of EUT Facing Phantom Bluetooth CH39

Date: 17/04/2015

DUT: Inari 8; Type: Tablet

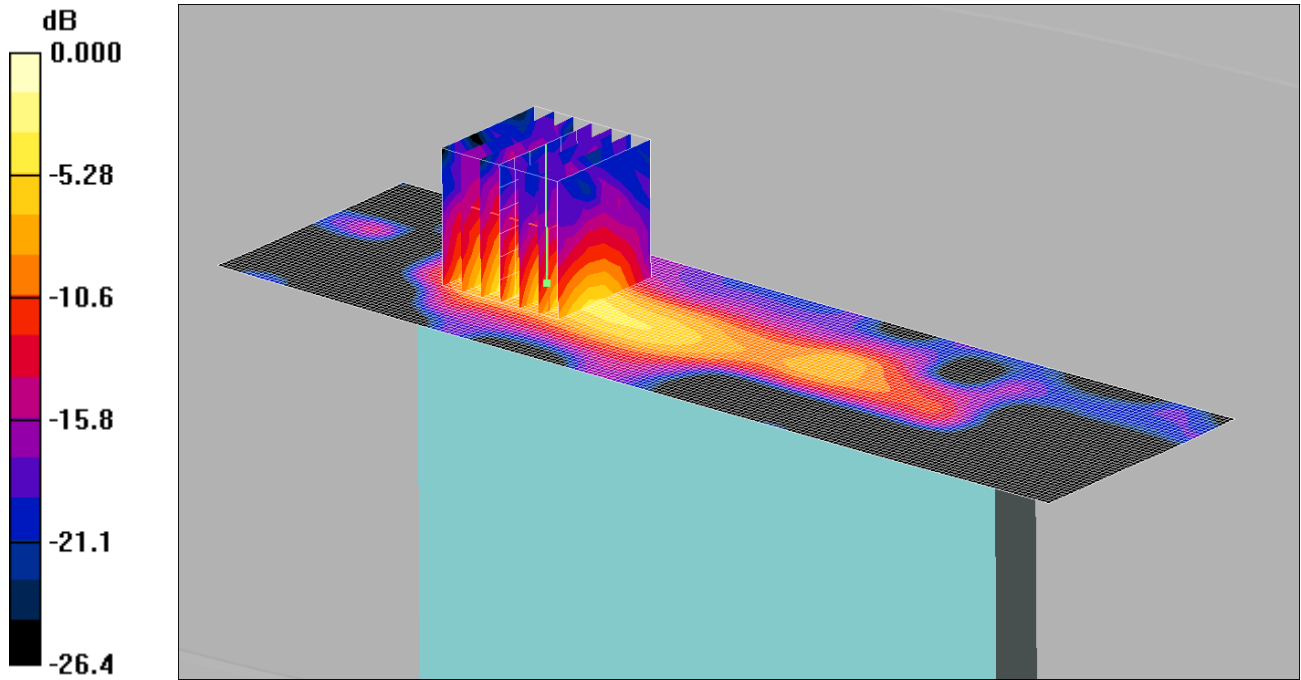

0 dB = 0.058mW/g

Communication System: Bluetooth; Frequency: 2441 MHz; Duty Cycle: 1:3.22

Medium: 2450 MHz MSL Medium parameters used (interpolated): $f = 2441 \text{ MHz}$; $\sigma = 1.91 \text{ mho/m}$; $\epsilon_r = 51.3$; $\rho = 1000 \text{ kg/m}^3$

Phantom section: Flat Section

DASY4 Configuration:

- Probe: ES3DV3 - SN3304; ConvF(4.24, 4.24, 4.24);
- Sensor-Surface: 4mm (Mechanical Surface Detection)
- Electronics: DAE3 Sn432; Calibrated: 20/08/2014
- Phantom: ELI v5.0; Type: QDOVA002AA; Serial: TP:xxxx
- Measurement SW: DASY4, V4.7 Build 80; Postprocessing SW: SEMCAD, V1.8 Build 186

Right Hand Side - Middle/Area Scan (51x181x1): Measurement grid: $dx=12\text{mm}$, $dy=12\text{mm}$
 Maximum value of SAR (interpolated) = 0.056 mW/g

Right Hand Side - Middle/Zoom Scan (7x7x7) (7x7x7)/Cube 0: Measurement grid: $dx=5\text{mm}$, $dy=5\text{mm}$, $dz=5\text{mm}$

Reference Value = 4.77 V/m; Power Drift = 0.080 dB

Peak SAR (extrapolated) = 0.115 W/kg

SAR(1 g) = 0.046 mW/g; SAR(10 g) = 0.017 mW/g

Maximum value of SAR (measured) = 0.058 mW/g

178: Back of EUT Facing Phantom Bluetooth CH0

Date: 17/04/2015

DUT: Inari 8; Type: Tablet

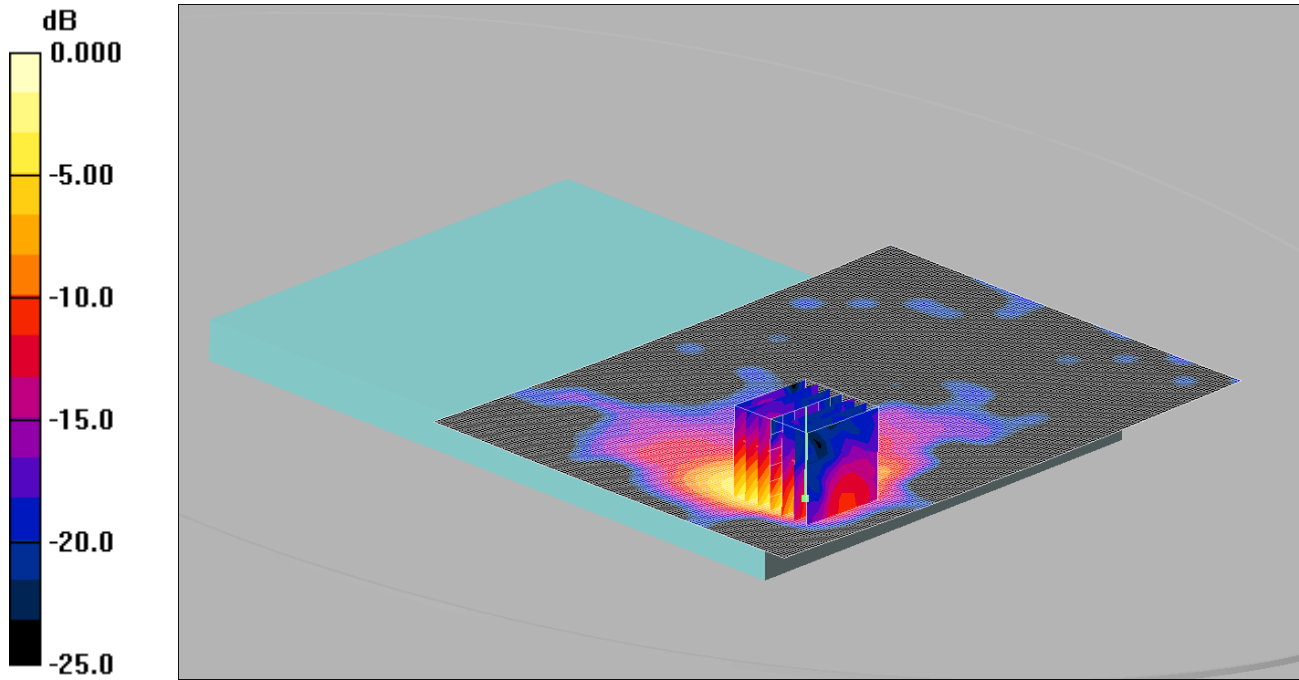

0 dB = 0.061mW/g

Communication System: Bluetooth; Frequency: 2402 MHz; Duty Cycle: 1:3.22

Medium: 2450 MHz MSL Medium parameters used (interpolated): $f = 2402$ MHz; $\sigma = 1.86$ mho/m; $\epsilon_r = 51.4$; $\rho = 1000$ kg/m³

Phantom section: Flat Section

DASY4 Configuration:

- Probe: ES3DV3 - SN3304; ConvF(4.24, 4.24, 4.24);
- Sensor-Surface: 4mm (Mechanical Surface Detection)
- Electronics: DAE3 Sn432; Calibrated: 20/08/2014
- Phantom: ELI v5.0; Type: QDOVA002AA; Serial: TP:xxxx
- Measurement SW: DASY4, V4.7 Build 80; Postprocessing SW: SEMCAD, V1.8 Build 186

Back - Low/Area Scan (161x121x1): Measurement grid: dx=12mm, dy=12mm
 Maximum value of SAR (interpolated) = 0.066 mW/g

Back - Low/Zoom Scan (7x7x7) (7x7x7)/Cube 0: Measurement grid: dx=5mm, dy=5mm, dz=5mm

Reference Value = 2.96 V/m; Power Drift = 0.189 dB

Peak SAR (extrapolated) = 0.141 W/kg

SAR(1 g) = 0.051 mW/g; SAR(10 g) = 0.021 mW/g

Maximum value of SAR (measured) = 0.061 mW/g

179: Back of EUT Facing Phantom Bluetooth CH78

Date: 17/04/2015

DUT: Inari 8; Type: Tablet

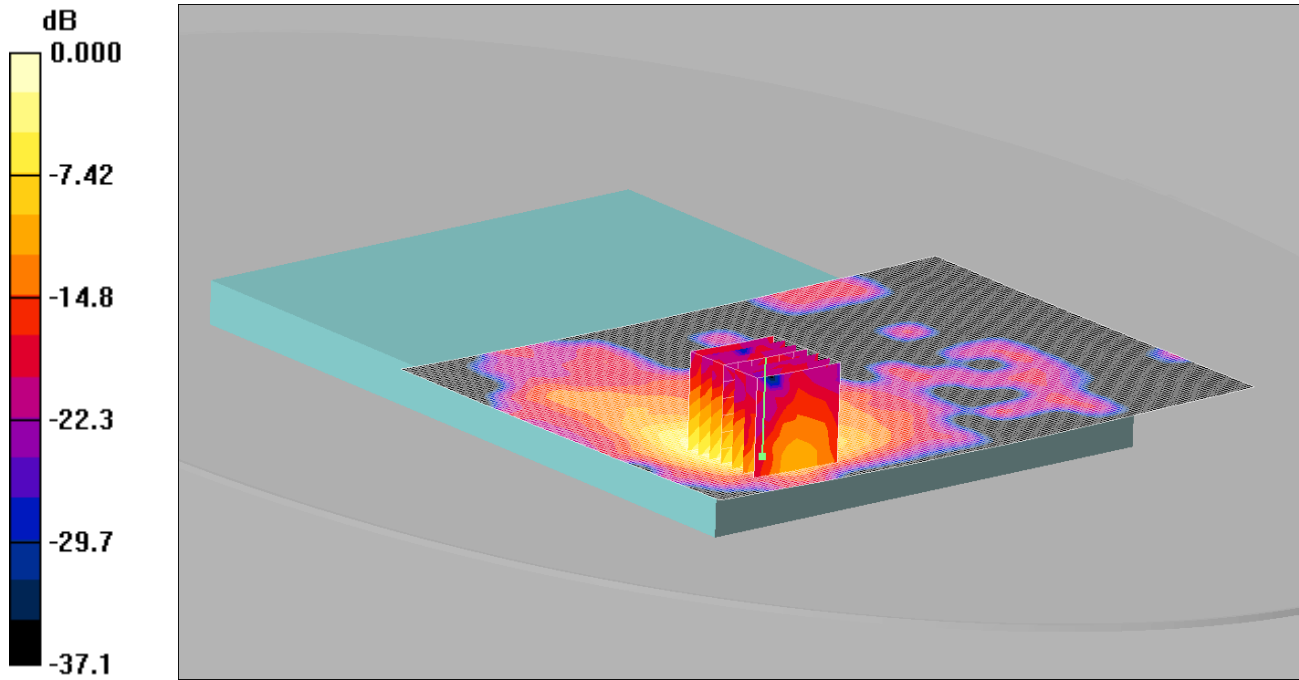

0 dB = 0.064mW/g

Communication System: Bluetooth; Frequency: 2480 MHz; Duty Cycle: 1:3.22

Medium: 2450 MHz MSL Medium parameters used (interpolated): $f = 2480$ MHz; $\sigma = 1.96$ mho/m; $\epsilon_r = 51.2$; $\rho = 1000$ kg/m³

Phantom section: Flat Section

DASY4 Configuration:

- Probe: ES3DV3 - SN3304; ConvF(4.24, 4.24, 4.24);
- Sensor-Surface: 4mm (Mechanical Surface Detection)
- Electronics: DAE3 Sn432; Calibrated: 20/08/2014
- Phantom: ELI v5.0; Type: QDOVA002AA; Serial: TP:xxxx
- Measurement SW: DASY4, V4.7 Build 80; Postprocessing SW: SEMCAD, V1.8 Build 186

Back - High/Area Scan (161x121x1): Measurement grid: dx=12mm, dy=12mm
 Maximum value of SAR (interpolated) = 0.071 mW/g

Back - High/Zoom Scan (7x7x7) (7x7x7)/Cube 0: Measurement grid: dx=5mm, dy=5mm, dz=5mm

Reference Value = 5.56 V/m; Power Drift = -0.087 dB

Peak SAR (extrapolated) = 0.149 W/kg

SAR(1 g) = 0.053 mW/g; SAR(10 g) = 0.021 mW/g

Maximum value of SAR (measured) = 0.064 mW/g