

#01_WCDMA II_RMC 12.2Kbps_Edge 4_0mm_Ch9538

Communication System: WCDMA; Frequency: 1907.6 MHz; Duty Cycle: 1:1

Medium: HSL_1900_190718 Medium parameters used: $f = 1908$ MHz; $\sigma = 1.423$ S/m; $\epsilon_r = 39.146$; $\rho = 1000$ kg/m³

Ambient Temperature : 23.6 °C ; Liquid Temperature : 22.6 °C

DASY5 Configuration

- Probe: EX3DV4 - SN3642; ConvF(7.91, 7.91, 7.91) @ 1907.6 MHz; Calibrated: 2019/4/29
- Sensor-Surface: 1.4mm (Mechanical Surface Detection)
- Electronics: DAE4 Sn1399; Calibrated: 2018/11/16
- Phantom: ELI v4.0; Type: QDOVA001BB; Serial: TP:1041
- Measurement SW: DASY52, Version 52.10 (2); SEMCAD X Version 14.6.12 (7470)

Area Scan (41x71x1): Interpolated grid: dx=1.500 mm, dy=1.500 mm

Maximum value of SAR (interpolated) = 1.82 W/kg

Zoom Scan (5x5x7)/Cube 0: Measurement grid: dx=8mm, dy=8mm, dz=5mm

Reference Value = 35.97 V/m; Power Drift = 0.02 dB

Peak SAR (extrapolated) = 2.14 W/kg

SAR(1 g) = 1.05 W/kg; SAR(10 g) = 0.513 W/kg

Maximum value of SAR (measured) = 1.68 W/kg

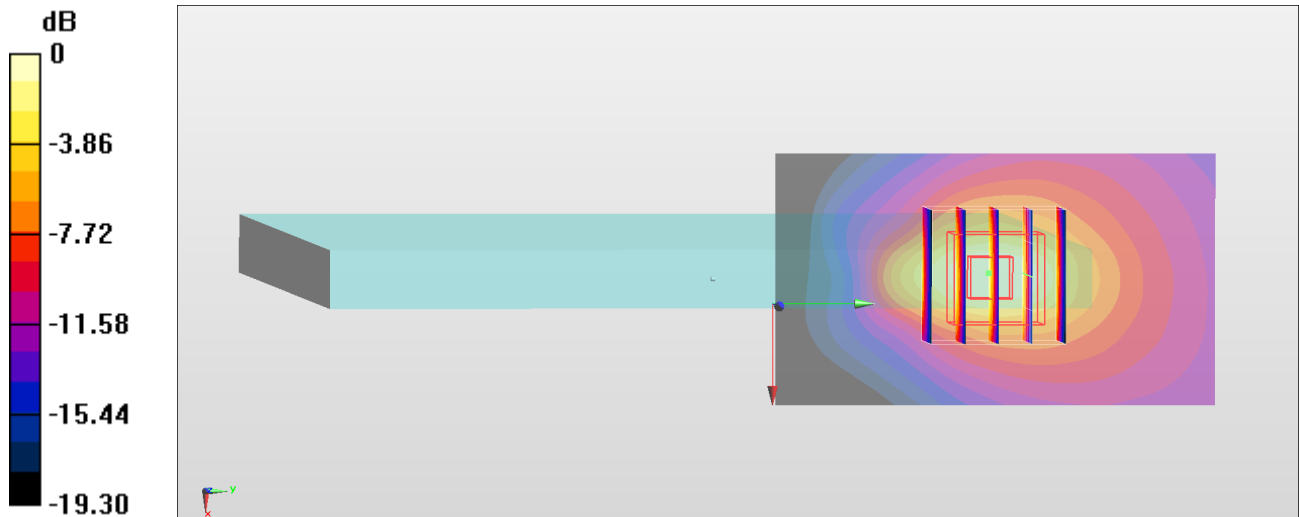

0 dB = 1.68 W/kg = 2.25 dBW/kg

#02_WCDMA IV_RMC 12.2Kbps_Edge 4_0mm_Ch1513

Communication System: WCDMA ; Frequency: 1752.6 MHz;Duty Cycle: 1:1

Medium: HSL_1750_190718 Medium parameters used: $f = 1753$ MHz; $\sigma = 1.372$ S/m; $\epsilon_r = 40.596$; $\rho = 1000$ kg/m³

Ambient Temperature : 23.6 °C ; Liquid Temperature : 22.6 °C

DASY5 Configuration

- Probe: EX3DV4 - SN3642;ConvF(8.18, 8.18, 8.18) @ 1752.6 MHz;Calibrated: 2019/4/29
- Sensor-Surface: 1.4mm (Mechanical Surface Detection)
- Electronics: DAE4 Sn1399; Calibrated: 2018/11/16
- Phantom: ELI v4.0; Type: QDOVA001BB; Serial: TP:1041
- Measurement SW: DASY52, Version 52.10 (2); SEMCAD X Version 14.6.12 (7470)

Area Scan (41x71x1): Interpolated grid: dx=1.500 mm, dy=1.500 mm

Maximum value of SAR (interpolated) = 1.38 W/kg

Zoom Scan (5x5x7)/Cube 0: Measurement grid: dx=8mm, dy=8mm, dz=5mm

Reference Value = 31.66 V/m; Power Drift = 0.03 dB

Peak SAR (extrapolated) = 1.98 W/kg

SAR(1 g) = 1.04 W/kg; SAR(10 g) = 0.514 W/kg

Maximum value of SAR (measured) = 1.33 W/kg

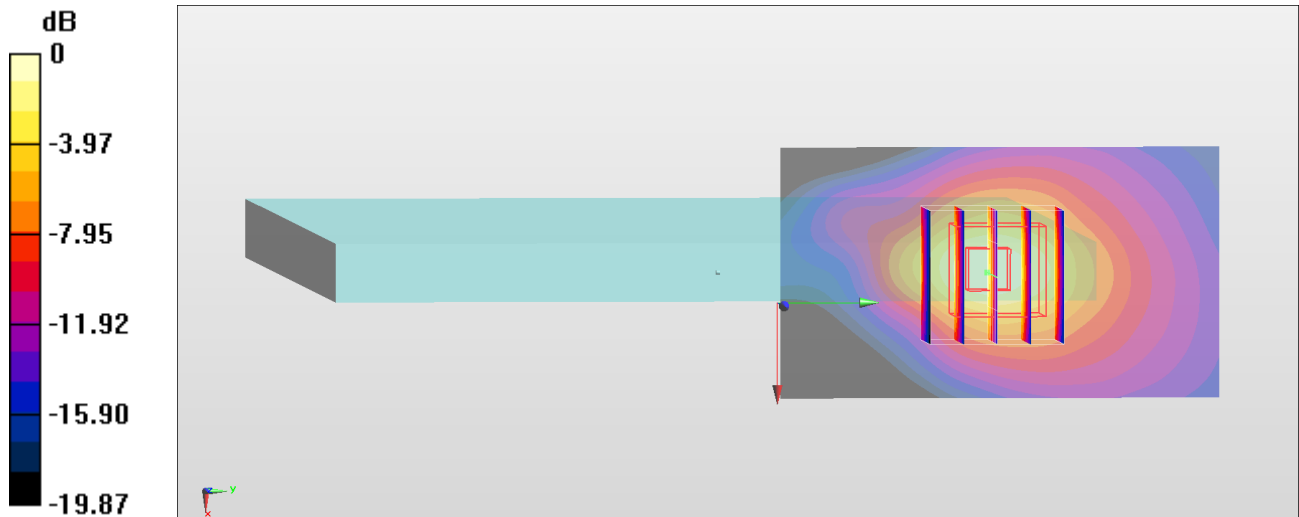

0 dB = 1.33 W/kg = 1.24 dBW/kg

#03_WCDMA V_RMC 12.2Kbps_Bottom Face_0mm_Ch4233

Communication System: WCDMA ; Frequency: 846.6 MHz;Duty Cycle: 1:1

Medium: HSL_850_190720 Medium parameters used: $f = 847$ MHz; $\sigma = 0.903$ S/m; $\epsilon_r = 41.488$; $\rho = 1000$ kg/m³

Ambient Temperature : 23.3 °C ; Liquid Temperature : 22.3 °C

DASY5 Configuration

- Probe: EX3DV4 - SN3642;ConvF(9.05, 9.05, 9.05) @ 846.6 MHz;Calibrated: 2019/4/29
- Sensor-Surface: 1.4mm (Mechanical Surface Detection)
- Electronics: DAE4 Sn1399; Calibrated: 2018/11/16
- Phantom: ELI v4.0; Type: QDOVA001BB; Serial: TP:1041
- Measurement SW: DASY52, Version 52.10 (2); SEMCAD X Version 14.6.12 (7470)

Area Scan (51x91x1): Interpolated grid: dx=1.500 mm, dy=1.500 mm

Maximum value of SAR (interpolated) = 2.44 W/kg

Zoom Scan (5x5x7)/Cube 0: Measurement grid: dx=8mm, dy=8mm, dz=5mm

Reference Value = 34.65 V/m; Power Drift = -0.19 dB

Peak SAR (extrapolated) = 3.38 W/kg

SAR(1 g) = 1.02 W/kg; SAR(10 g) = 0.450 W/kg

Maximum value of SAR (measured) = 2.33 W/kg

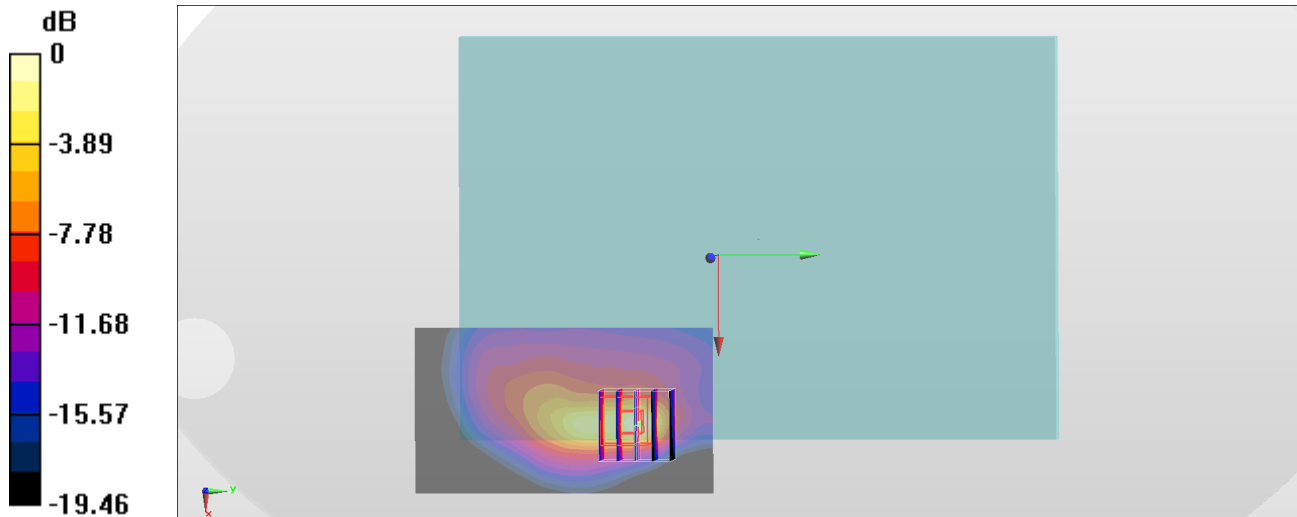

0 dB = 2.33 W/kg = 3.67 dBW/kg

#04_LTE Band 7_20M_QPSK_1_0_Edge 1_12mm_Ch21350

Communication System: LTE; Frequency: 2560 MHz; Duty Cycle: 1:1

Medium: HSL_2600_190714 Medium parameters used: $f = 2560$ MHz; $\sigma = 1.977$ S/m; $\epsilon_r = 39.407$; $\rho = 1000$ kg/m³

Ambient Temperature : 23.3 °C ; Liquid Temperature : 22.3 °C

DASY5 Configuration:

- Probe: EX3DV4 - SN3931; ConvF(7.3, 7.3, 7.3) @ 2560 MHz; Calibrated: 2018/9/27
- Sensor-Surface: 1.4mm (Mechanical Surface Detection)
- Electronics: DAE4 Sn1326; Calibrated: 2018/9/18
- Phantom: ELI v5.0; Type: QDOVA002AA; Serial: TP:1227
- Measurement SW: DASY52, Version 52.10 (2); SEMCAD X Version 14.6.12 (7470)

Area Scan (51x91x1): Interpolated grid: dx=1.200 mm, dy=1.200 mm

Maximum value of SAR (interpolated) = 1.62 W/kg

Zoom Scan (7x7x7)/Cube 0: Measurement grid: dx=5mm, dy=5mm, dz=5mm

Reference Value = 29.73 V/m; Power Drift = 0.17 dB

Peak SAR (extrapolated) = 2.03 W/kg

SAR(1 g) = 0.931 W/kg; SAR(10 g) = 0.496 W/kg

Maximum value of SAR (measured) = 1.62 W/kg

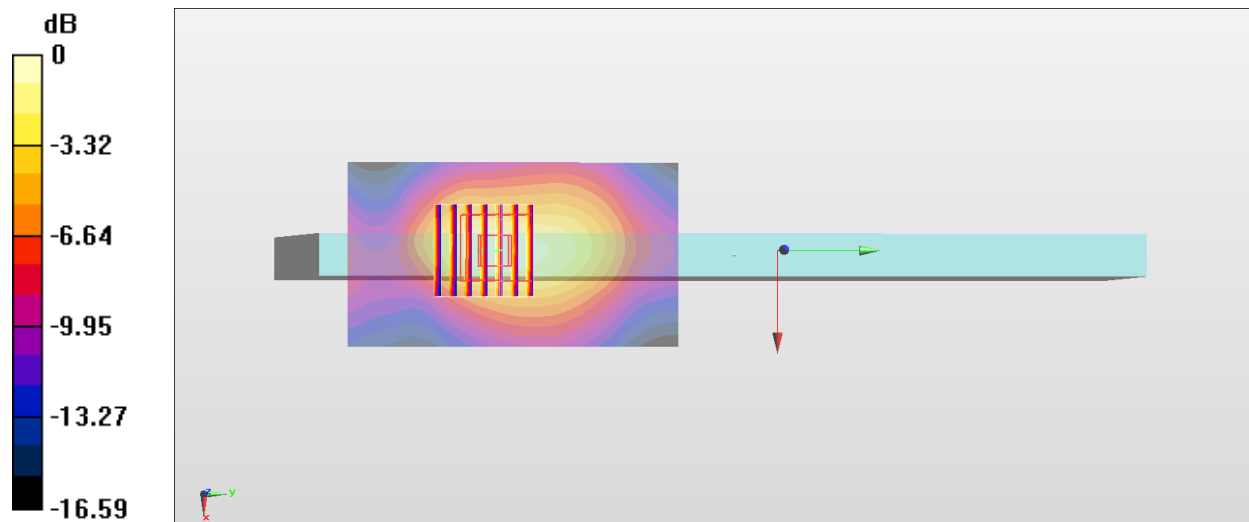

0 dB = 1.62 W/kg = 2.10 dBW/kg

#05_LTE Band 12_10M_QPSK_25_0_Bottom Face_0mm_Ch23095

Communication System: LTE; Frequency: 707.5 MHz; Duty Cycle: 1:1

Medium: HSL_750_190722 Medium parameters used: $f = 707.5$ MHz; $\sigma = 0.849$ S/m; $\epsilon_r = 40.866$; $\rho = 1000$ kg/m³

Ambient Temperature : 23.3 °C ; Liquid Temperature : 22.3 °C

DASY5 Configuration

- Probe: EX3DV4 - SN3642; ConvF(9.16, 9.16, 9.16) @ 707.5 MHz; Calibrated: 2019/4/29
- Sensor-Surface: 1.4mm (Mechanical Surface Detection)
- Electronics: DAE4 Sn1399; Calibrated: 2018/11/16
- Phantom: ELI v4.0; Type: QDOVA001BB; Serial: TP:1041
- Measurement SW: DASY52, Version 52.10 (2); SEMCAD X Version 14.6.12 (7470)

Area Scan (51x91x1): Interpolated grid: dx=1.500 mm, dy=1.500 mm

Maximum value of SAR (interpolated) = 1.27 W/kg

Zoom Scan (5x5x7)/Cube 0: Measurement grid: dx=8mm, dy=8mm, dz=5mm

Reference Value = 31.10 V/m; Power Drift = -0.03 dB

Peak SAR (extrapolated) = 2.82 W/kg

SAR(1 g) = 0.874 W/kg; SAR(10 g) = 0.403 W/kg

Maximum value of SAR (measured) = 1.72 W/kg

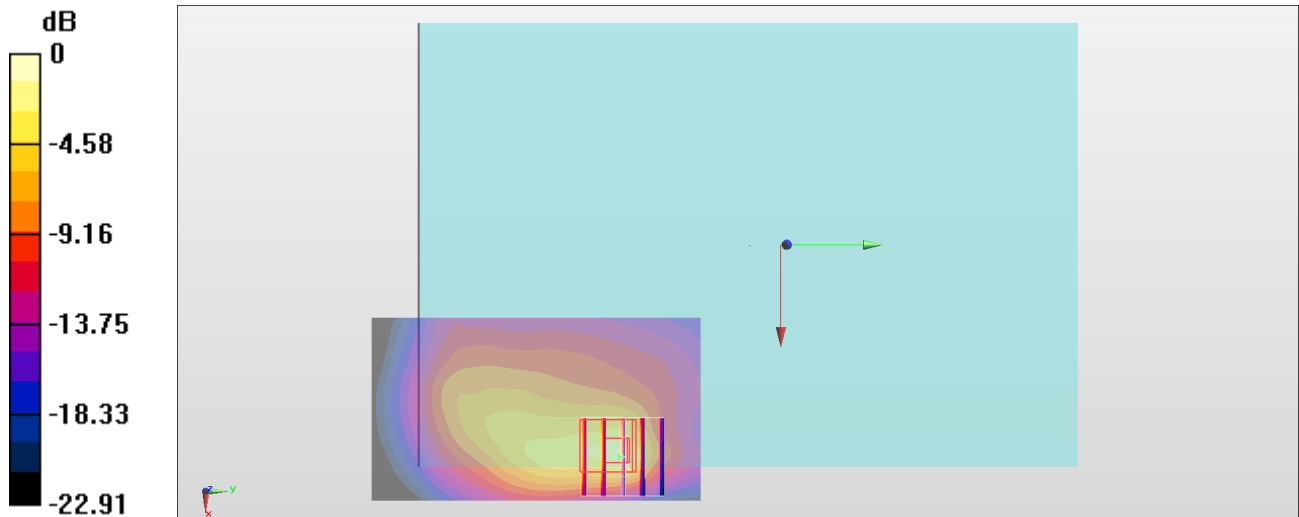

0 dB = 1.72 W/kg = 2.36 dBW/kg

#06_LTE Band 13_10M_QPSK_1_0_Edge 1_0mm_Ch23230

Communication System: LTE; Frequency: 782 MHz; Duty Cycle: 1:1

Medium: HSL_750_190722 Medium parameters used: $f = 782$ MHz; $\sigma = 0.918$ S/m; $\epsilon_r = 40.008$; $\rho = 1000$ kg/m³

Ambient Temperature : 23.3 °C ; Liquid Temperature : 22.3 °C

DASY5 Configuration

- Probe: EX3DV4 - SN3642; ConvF(9.16, 9.16, 9.16) @ 782 MHz; Calibrated: 2019/4/29
- Sensor-Surface: 1.4mm (Mechanical Surface Detection)
- Electronics: DAE4 Sn1399; Calibrated: 2018/11/16
- Phantom: ELI v4.0; Type: QDOVA001BB; Serial: TP:1041
- Measurement SW: DASY52, Version 52.10 (2); SEMCAD X Version 14.6.12 (7470)

Area Scan (51x91x1): Interpolated grid: dx=1.500 mm, dy=1.500 mm

Maximum value of SAR (interpolated) = 1.76 W/kg

Zoom Scan (5x5x7)/Cube 0: Measurement grid: dx=8mm, dy=8mm, dz=5mm

Reference Value = 51.86 V/m; Power Drift = -0.04 dB

Peak SAR (extrapolated) = 3.16 W/kg

SAR(1 g) = 1.04 W/kg; SAR(10 g) = 0.471 W/kg

Maximum value of SAR (measured) = 1.81 W/kg

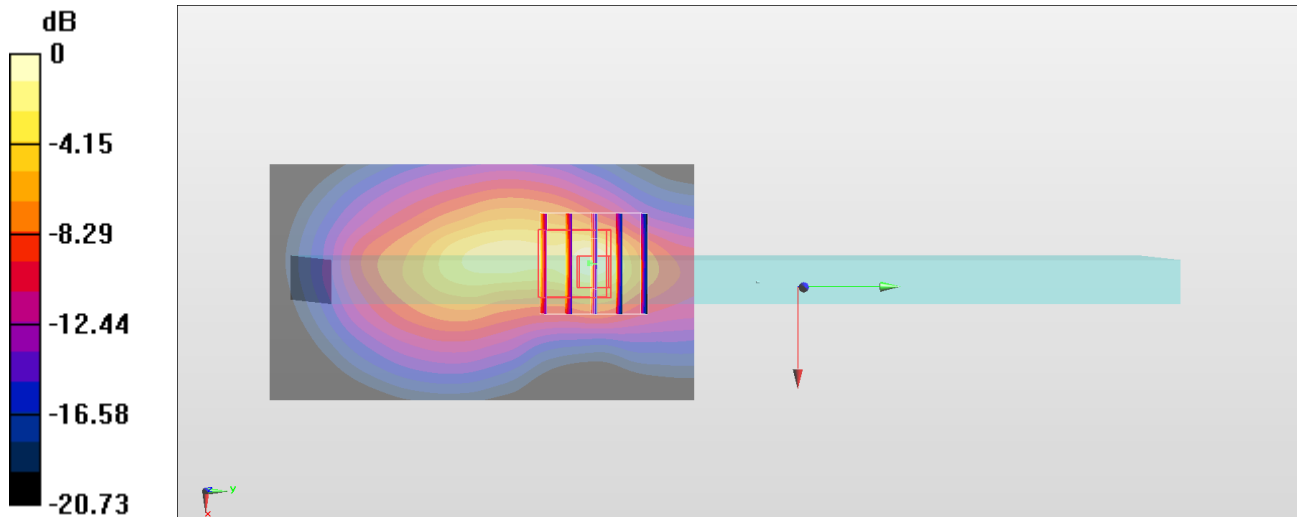

0 dB = 1.81 W/kg = 2.58 dBW/kg

#07_LTE Band 25_20M_QPSK_50_0_Edge 4_0mm_Ch26590

Communication System: LTE; Frequency: 1905 MHz; Duty Cycle: 1:1

Medium: HSL_1900_190718 Medium parameters used : $f = 1905$ MHz; $\sigma = 1.42$ S/m; $\epsilon_r = 39.16$; $\rho = 1000$ kg/m³

Ambient Temperature : 23.6 °C ; Liquid Temperature : 22.6 °C

DASY5 Configuration

- Probe: EX3DV4 - SN3642; ConvF(7.91, 7.91, 7.91) @ 1905 MHz; Calibrated: 2019/4/29
- Sensor-Surface: 1.4mm (Mechanical Surface Detection)
- Electronics: DAE4 Sn1399; Calibrated: 2018/11/16
- Phantom: ELI v4.0; Type: QDOVA001BB; Serial: TP:1041
- Measurement SW: DASY52, Version 52.10 (2); SEMCAD X Version 14.6.12 (7470)

Area Scan (41x71x1): Interpolated grid: dx=1.500 mm, dy=1.500 mm

Maximum value of SAR (interpolated) = 1.56 W/kg

Zoom Scan (5x5x7)/Cube 0: Measurement grid: dx=8mm, dy=8mm, dz=5mm

Reference Value = 33.61 V/m; Power Drift = -0.08 dB

Peak SAR (extrapolated) = 1.95 W/kg

SAR(1 g) = 0.956 W/kg; SAR(10 g) = 0.448 W/kg

Maximum value of SAR (measured) = 1.57 W/kg

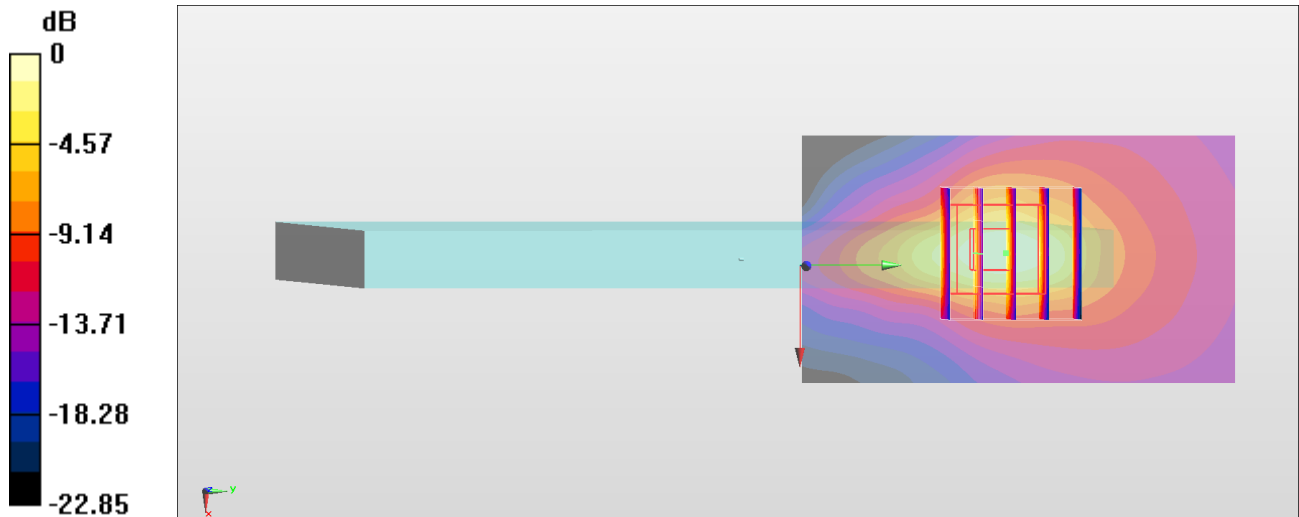

0 dB = 1.57 W/kg = 1.96 dBW/kg

#08_LTE Band 26_15M_QPSK_1_0_Bottom Face_0mm_Ch26865

Communication System: LTE; Frequency: 831.5 MHz; Duty Cycle: 1:1

Medium: HSL_850_190720 Medium parameters used: $f = 831.5$ MHz; $\sigma = 0.889$ S/m; $\epsilon_r = 41.69$; $\rho = 1000$ kg/m³

Ambient Temperature : 23.3 °C ; Liquid Temperature : 22.3 °C

DASY5 Configuration

- Probe: EX3DV4 - SN3642; ConvF(9.05, 9.05, 9.05) @ 831.5 MHz; Calibrated: 2019/4/29
- Sensor-Surface: 1.4mm (Mechanical Surface Detection)
- Electronics: DAE4 Sn1399; Calibrated: 2018/11/16
- Phantom: ELI v4.0; Type: QDOVA001BB; Serial: TP:1041
- Measurement SW: DASY52, Version 52.10 (2); SEMCAD X Version 14.6.12 (7470)

Area Scan (51x91x1): Interpolated grid: dx=1.500 mm, dy=1.500 mm

Maximum value of SAR (interpolated) = 1.53 W/kg

Zoom Scan (5x5x7)/Cube 0: Measurement grid: dx=8mm, dy=8mm, dz=5mm

Reference Value = 33.83 V/m; Power Drift = -0.07 dB

Peak SAR (extrapolated) = 3.10 W/kg

SAR(1 g) = 1.06 W/kg; SAR(10 g) = 0.495 W/kg

Maximum value of SAR (measured) = 1.97 W/kg

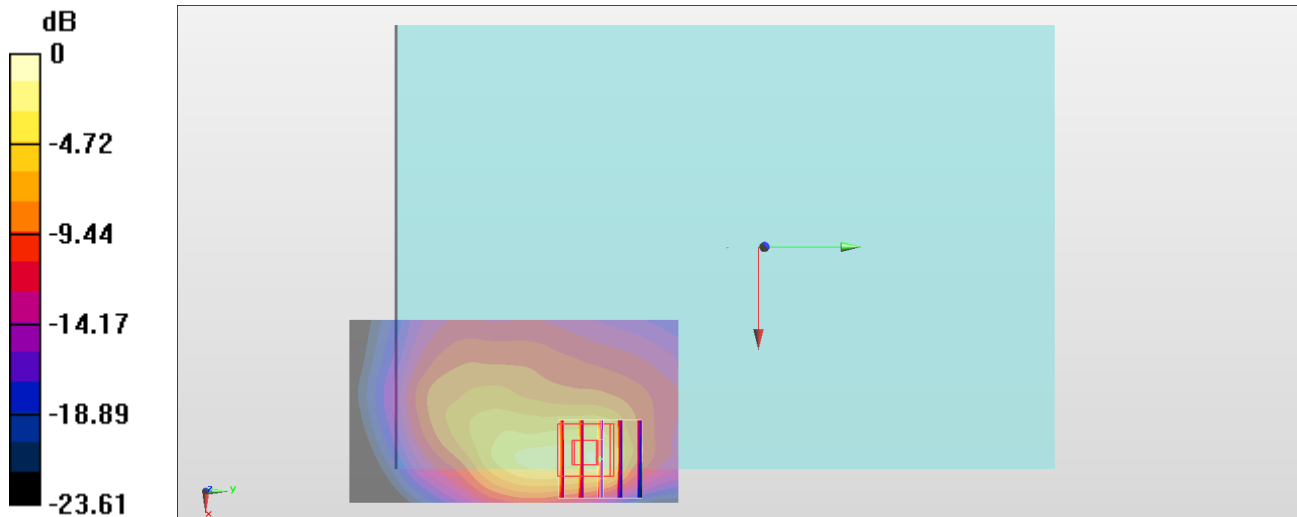

0 dB = 1.97 W/kg = 2.94 dBW/kg

#09_LTE Band 30_10M_QPSK_25_0_Bottom Face_0mm_Ch27710

Communication System: LTE; Frequency: 2310 MHz; Duty Cycle: 1:1

Medium: HSL_2300_190707 Medium parameters used: $f = 2310$ MHz; $\sigma = 1.701$ S/m; $\epsilon_r = 40.465$; $\rho = 1000$ kg/m³

Ambient Temperature : 23.2 °C ; Liquid Temperature : 22.2 °C

DASY5 Configuration:

- Probe: EX3DV4 - SN3931; ConvF(7.83, 7.83, 7.83) @ 2310 MHz; Calibrated: 2018/9/27
- Sensor-Surface: 1.4mm (Mechanical Surface Detection)
- Electronics: DAE4 Sn1326; Calibrated: 2018/9/18
- Phantom: ELI v5.0; Type: QDOVA002AA; Serial: TP:1227
- Measurement SW: DASY52, Version 52.10 (2); SEMCAD X Version 14.6.12 (7470)

Area Scan (51x81x1): Interpolated grid: dx=1.200 mm, dy=1.200 mm

Maximum value of SAR (interpolated) = 1.83 W/kg

Zoom Scan (7x7x7)/Cube 0: Measurement grid: dx=5mm, dy=5mm, dz=5mm

Reference Value = 20.39 V/m; Power Drift = -0.13 dB

Peak SAR (extrapolated) = 2.75 W/kg

SAR(1 g) = 0.941 W/kg; SAR(10 g) = 0.371 W/kg

Maximum value of SAR (measured) = 1.99 W/kg

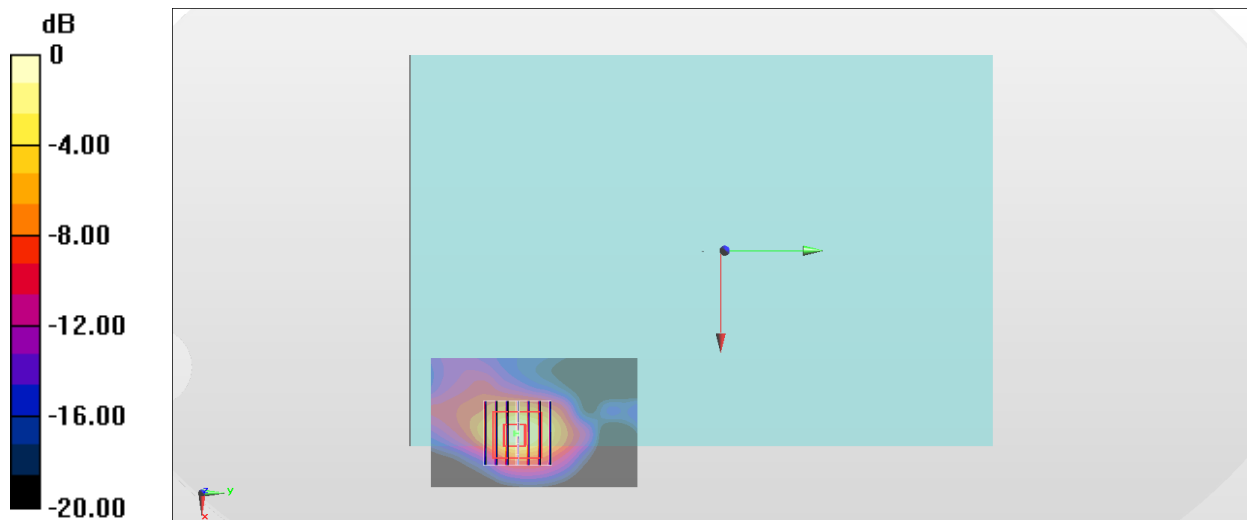

0 dB = 1.83 W/kg = 2.62 dBW/kg

#10_LTE Band 66_20M_QPSK_1_0_Bottom Face_0mm_Ch132072

Communication System: LTE ; Frequency: 1720 MHz;Duty Cycle: 1:1

Medium: HSL_1750_190718 Medium parameters used: $f = 1720$ MHz; $\sigma = 1.342$ S/m; $\epsilon_r = 40.676$; $\rho = 1000$ kg/m³

Ambient Temperature : 23.6 °C ; Liquid Temperature : 22.6 °C

DASY5 Configuration

- Probe: EX3DV4 - SN3642;ConvF(8.18, 8.18, 8.18) @ 1720 MHz;Calibrated: 2019/4/29
- Sensor-Surface: 1.4mm (Mechanical Surface Detection)
- Electronics: DAE4 Sn1399; Calibrated: 2018/11/16
- Phantom: ELI v4.0; Type: QDOVA001BB; Serial: TP:1041
- Measurement SW: DASY52, Version 52.10 (2); SEMCAD X Version 14.6.12 (7470)

Area Scan (51x91x1): Interpolated grid: dx=1.500 mm, dy=1.500 mm

Maximum value of SAR (interpolated) = 1.95 W/kg

Zoom Scan (5x5x7)/Cube 0: Measurement grid: dx=8mm, dy=8mm, dz=5mm

Reference Value = 33.17 V/m; Power Drift = -0.01 dB

Peak SAR (extrapolated) = 2.93 W/kg

SAR(1 g) = 1.1 W/kg; SAR(10 g) = 0.601 W/kg

Maximum value of SAR (measured) = 2.08 W/kg

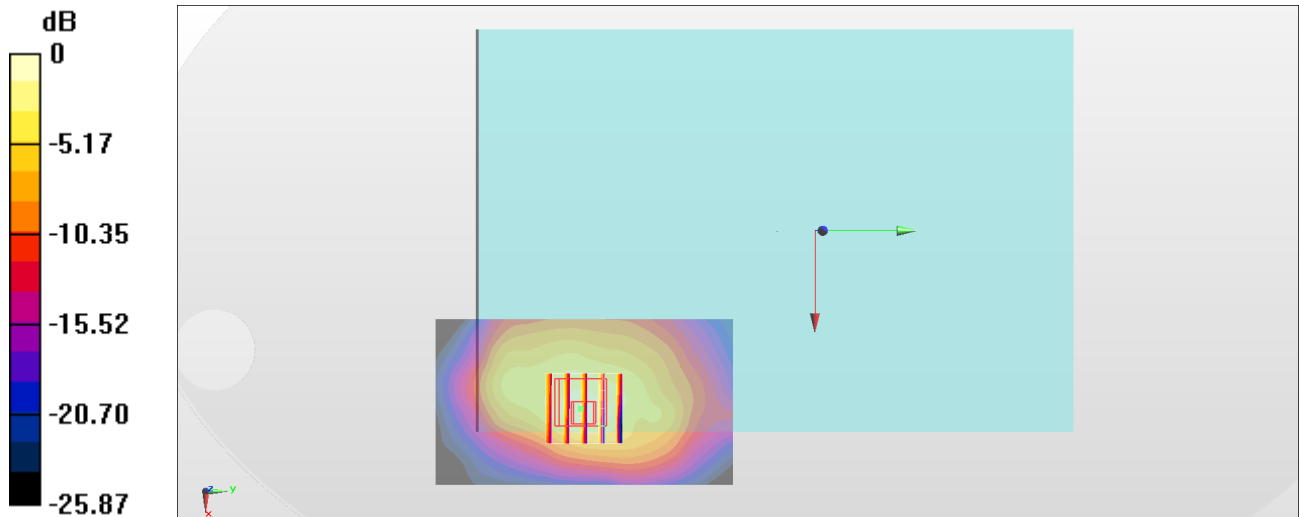

0 dB = 2.08 W/kg = 3.18 dBW/kg

#11_LTE Band 41_20M_QPSK_1_99_Bottom Face_0mm_Ch40620

Communication System: LTE; Frequency: 2593 MHz; Duty Cycle: 1:1.59

Medium: HSL_2600_190714 Medium parameters used : $f = 2593$ MHz; $\sigma = 2.014$ S/m; $\epsilon_r = 39.306$; $\rho = 1000$ kg/m³

Ambient Temperature : 23.3 °C ; Liquid Temperature : 22.3 °C

DASY5 Configuration:

- Probe: EX3DV4 - SN3931; ConvF(7.3, 7.3, 7.3) @ 2593 MHz; Calibrated: 2018/9/27
- Sensor-Surface: 1.4mm (Mechanical Surface Detection)
- Electronics: DAE4 Sn1326; Calibrated: 2018/9/18
- Phantom: ELI v5.0; Type: QDOVA002AA; Serial: TP:1227
- Measurement SW: DASY52, Version 52.10 (2); SEMCAD X Version 14.6.12 (7470)

Area Scan (51x81x1): Interpolated grid: dx=1.200 mm, dy=1.200 mm

Maximum value of SAR (interpolated) = 2.20 W/kg

Zoom Scan (7x7x7)/Cube 0: Measurement grid: dx=5mm, dy=5mm, dz=5mm

Reference Value = 17.93 V/m; Power Drift = -0.14 dB

Peak SAR (extrapolated) = 3.04 W/kg

SAR(1 g) = 0.949 W/kg; SAR(10 g) = 0.360 W/kg

Maximum value of SAR (measured) = 1.89 W/kg

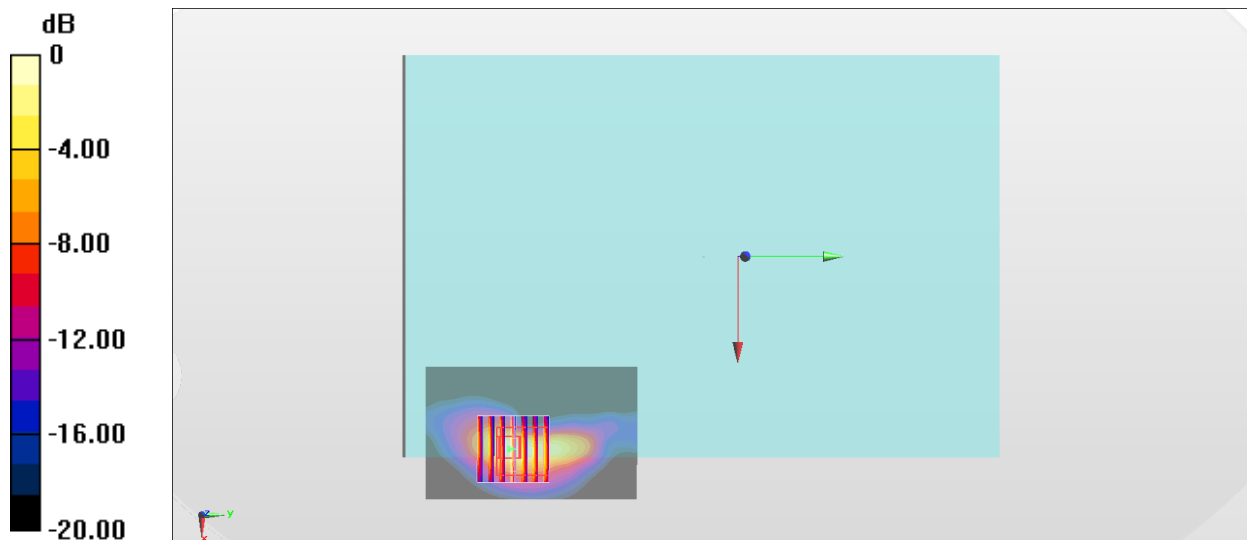

#12_WLAN2.4GHz_802.11b 1Mbps_Bottom Face_0mm_Ch1;Ant 11

Communication System: 802.11b ; Frequency: 2462 MHz;Duty Cycle: 1:1.012

Medium: HSL_2450_190729 Medium parameters used: $f = 2462$ MHz; $\sigma = 1.784$ S/m; $\epsilon_r = 38.526$; $\rho = 1000$ kg/m³

Ambient Temperature : 23.6 °C ; Liquid Temperature : 22.6 °C

DASY5 Configuration:

- Probe: EX3DV4 - SN3898;ConvF(7.56, 7.56, 7.56) @ 2462 MHz;Calibrated: 2019/6/27
- Sensor-Surface: 1.4mm (Mechanical Surface Detection)
- Electronics: DAE3 Sn495; Calibrated: 2019/5/21
- Phantom: ELI v5.0; Type: QDOVA002AA; Serial: TP:1238
- Measurement SW: DASY52, Version 52.10 (2);SEMCAD X Version 14.6.12 (7470)

Area Scan (71x81x1): Interpolated grid: dx=1.200 mm, dy=1.200 mm

Maximum value of SAR (interpolated) = 2.65 W/kg

Zoom Scan (7x7x7)/Cube 0: Measurement grid: dx=5mm, dy=5mm, dz=5mm

Reference Value = 25.66 V/m; Power Drift = -0.17 dB

Peak SAR (extrapolated) = 3.42 W/kg

SAR(1 g) = 1.17 W/kg; SAR(10 g) = 0.454 W/kg

Maximum value of SAR (measured) = 2.36 W/kg

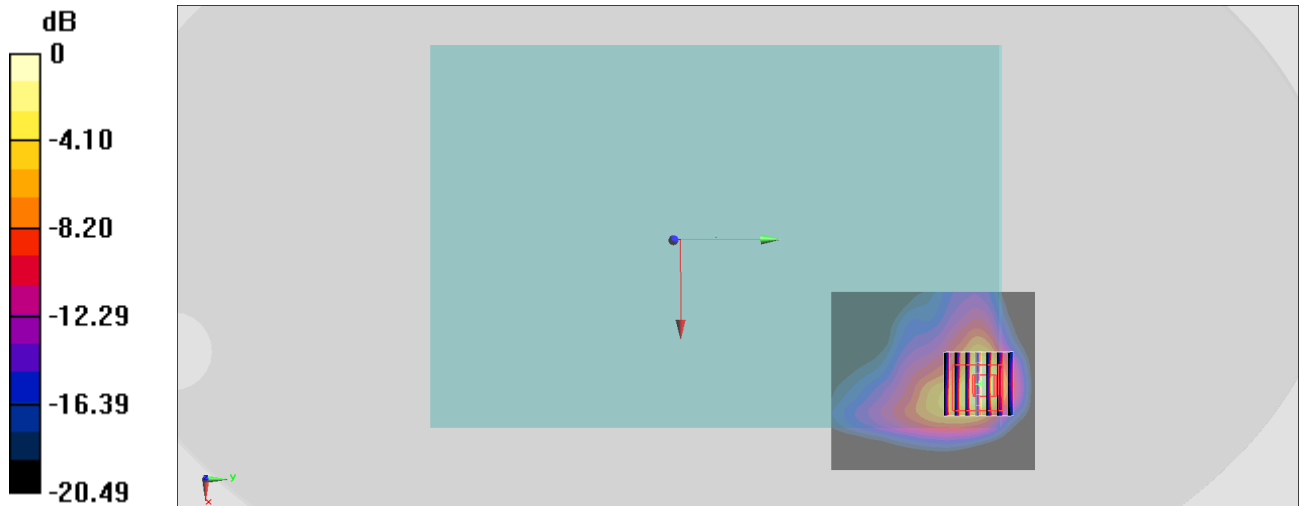

0 dB = 2.36 W/kg = 3.73 dBW/kg

#13_WLAN5GHz_802.11ac-VHT80 MCS0_Edge 2_0mm_Ch58;Ant 1

Communication System: 802.11ac ; Frequency: 5290 MHz;Duty Cycle: 1:1.079

Medium: HSL_5G_190730 Medium parameters used (interpolated): $f = 5290$ MHz; $\sigma = 4.765$ S/m; $\epsilon_r =$

36.554 ; $\rho = 1000$ kg/m³

Ambient Temperature : 23.6 °C ; Liquid Temperature : 22.6 °C

DASY5 Configuration:

- Probe: EX3DV4 - SN3898;ConvF(5.33, 5.33, 5.33) @ 5290 MHz;Calibrated: 2019/6/27

- Sensor-Surface: 1.4mm (Mechanical Surface Detection)

- Electronics: DAE3 Sn495; Calibrated: 2019/5/21

- Phantom: ELI v4.0_Left; Type: QDOVA001BB; Serial: TP:1029

- Measurement SW: DASY52, Version 52.10 (2);SEMCAD X Version 14.6.12 (7470)

Area Scan (81x101x1): Interpolated grid: $dx=1.000$ mm, $dy=1.000$ mm

Maximum value of SAR (interpolated) = 1.91 W/kg

Zoom Scan (7x7x7)/Cube 0: Measurement grid: $dx=4$ mm, $dy=4$ mm, $dz=1.4$ mm

Reference Value = 11.29 V/m; Power Drift = 0.04 dB

Peak SAR (extrapolated) = 4.66 W/kg

SAR(1 g) = 1.04 W/kg; SAR(10 g) = 0.282 W/kg

Maximum value of SAR (measured) = 2.78 W/kg

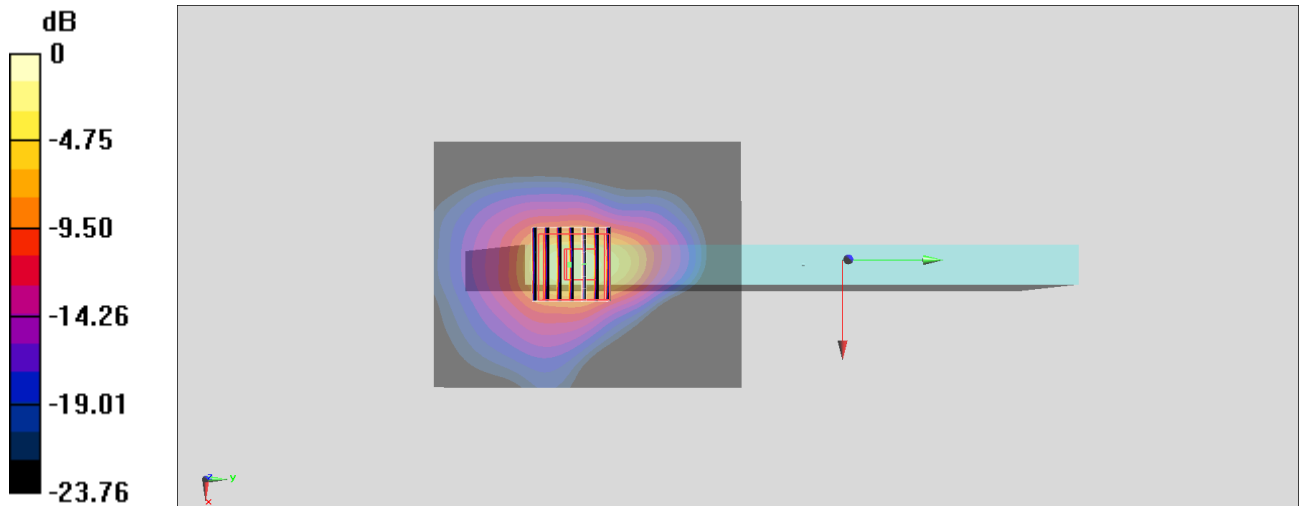

0 dB = 2.78 W/kg = 4.44 dBW/kg

#14_WLAN5GHz_802.11ac-VHT80 MCS0_Edge 2_0mm_Ch122;Ant 1

Communication System: 802.11ac ; Frequency: 5610 MHz;Duty Cycle: 1:1.079

Medium: HSL_5G_190730 Medium parameters used : $f = 5610$ MHz; $\sigma = 5.096$ S/m; $\epsilon_r = 36.147$; $\rho = 1000$ kg/m³

Ambient Temperature : 23.6 °C ; Liquid Temperature : 22.6 °C

DASY5 Configuration:

- Probe: EX3DV4 - SN3898;ConvF(4.85, 4.85, 4.85) @ 5610 MHz;Calibrated: 2019/6/27
- Sensor-Surface: 1.4mm (Mechanical Surface Detection)
- Electronics: DAE3 Sn495; Calibrated: 2019/5/21
- Phantom: ELI v4.0_Left; Type: QDOVA001BB; Serial: TP:1029
- Measurement SW: DASY52, Version 52.10 (2);SEMCAD X Version 14.6.12 (7470)

Area Scan (81x101x1): Interpolated grid: dx=1.000 mm, dy=1.000 mm

Maximum value of SAR (interpolated) = 1.89 W/kg

Zoom Scan (7x7x7)/Cube 0: Measurement grid: dx=4mm, dy=4mm, dz=1.4mm

Reference Value = 10.06 V/m; Power Drift = -0.10 dB

Peak SAR (extrapolated) = 3.99 W/kg

SAR(1 g) = 0.827 W/kg; SAR(10 g) = 0.238 W/kg

Maximum value of SAR (measured) = 2.19 W/kg

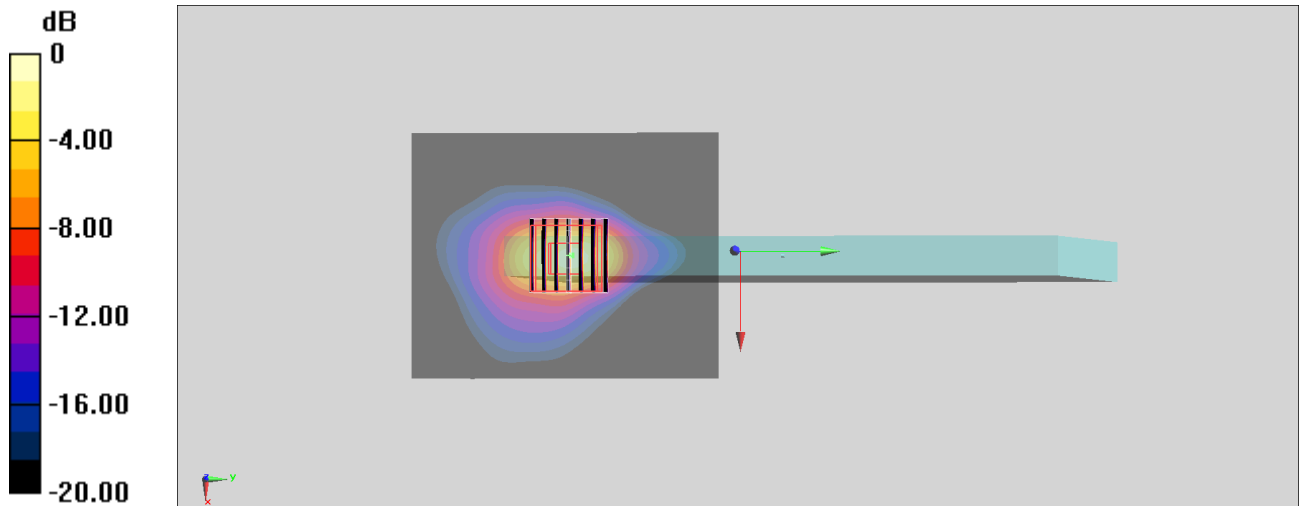

0 dB = 2.19 W/kg = 3.40 dBW/kg

#15_WLAN5GHz_802.11ac-VHT80 MCS0_Edge 2_0mm_Ch155;Ant 1

Communication System: 802.11ac ; Frequency: 5775 MHz;Duty Cycle: 1:1.079

Medium: HSL_5G_190730 Medium parameters used: $f = 5775$ MHz; $\sigma = 5.284$ S/m; $\epsilon_r = 35.939$; $\rho = 1000$ kg/m³

Ambient Temperature : 23.6 °C ; Liquid Temperature : 22.6 °C

DASY5 Configuration:

- Probe: EX3DV4 - SN3898;ConvF(4.95, 4.95, 4.95) @ 5775 MHz;Calibrated: 2019/6/27
- Sensor-Surface: 1.4mm (Mechanical Surface Detection)
- Electronics: DAE3 Sn495; Calibrated: 2019/5/21
- Phantom: ELI v4.0_Left; Type: QDOVA001BB; Serial: TP:1029
- Measurement SW: DASY52, Version 52.10 (2);SEMCAD X Version 14.6.12 (7470)

Area Scan (81x101x1): Interpolated grid: dx=1.000 mm, dy=1.000 mm

Maximum value of SAR (interpolated) = 2.64 W/kg

Zoom Scan (7x7x7)/Cube 0: Measurement grid: dx=4mm, dy=4mm, dz=1.4mm

Reference Value = 9.763 V/m; Power Drift = 0.16 dB

Peak SAR (extrapolated) = 4.58 W/kg

SAR(1 g) = 0.997 W/kg; SAR(10 g) = 0.291 W/kg

Maximum value of SAR (measured) = 2.61 W/kg

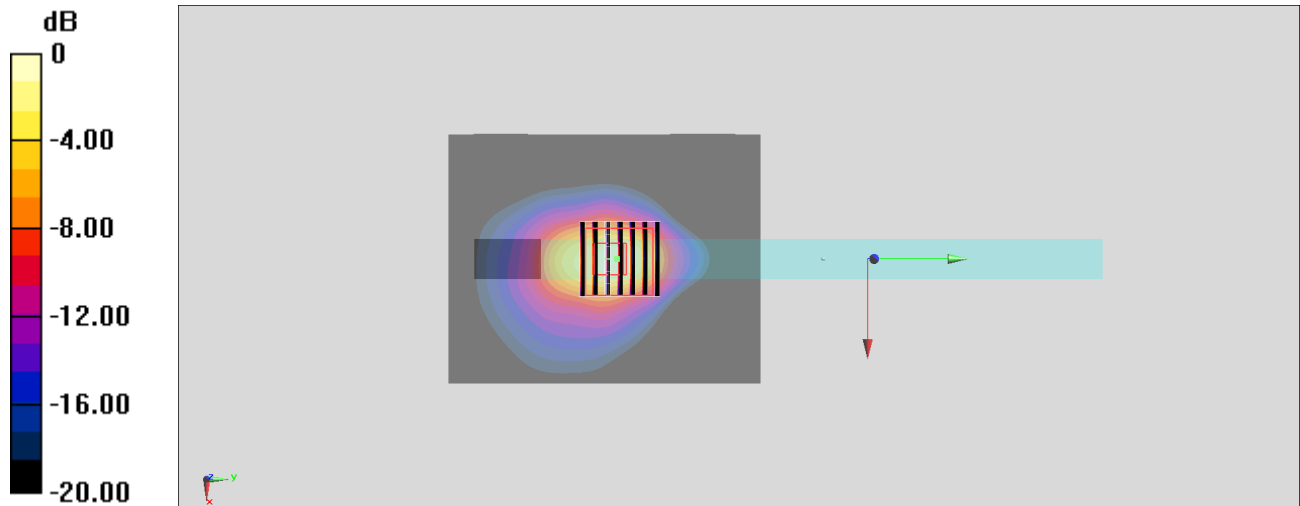

0 dB = 2.61 W/kg = 4.17 dBW/kg

#16_Bluetooth_1Mbps_Edge 2_0mm_Ch78

Communication System: Bluetooth; Frequency: 2480 MHz; Duty Cycle: 1:1.297

Medium: HSL_2450_190729 Medium parameters used: $f = 2480$ MHz; $\sigma = 1.805$ S/m; $\epsilon_r = 38.443$; $\rho = 1000$ kg/m³

Ambient Temperature : 23.6 °C ; Liquid Temperature : 22.6 °C

DASY5 Configuration:

- Probe: EX3DV4 - SN3898; ConvF(7.56, 7.56, 7.56) @ 2480 MHz; Calibrated: 2019/6/27
- Sensor-Surface: 1.4mm (Mechanical Surface Detection)
- Electronics: DAE3 Sn495; Calibrated: 2019/5/21
- Phantom: ELI v5.0; Type: QDOVA002AA; Serial: TP:1238
- Measurement SW: DASY52, Version 52.10 (2); SEMCAD X Version 14.6.12 (7470)

Area Scan (61x101x1): Interpolated grid: dx=1.200 mm, dy=1.200 mm

Maximum value of SAR (interpolated) = 0.879 W/kg

Zoom Scan (7x7x7)/Cube 0: Measurement grid: dx=5mm, dy=5mm, dz=5mm

Reference Value = 15.02 V/m; Power Drift = -0.13 dB

Peak SAR (extrapolated) = 1.09 W/kg

SAR(1 g) = 0.439 W/kg; SAR(10 g) = 0.159 W/kg

Maximum value of SAR (measured) = 0.818 W/kg

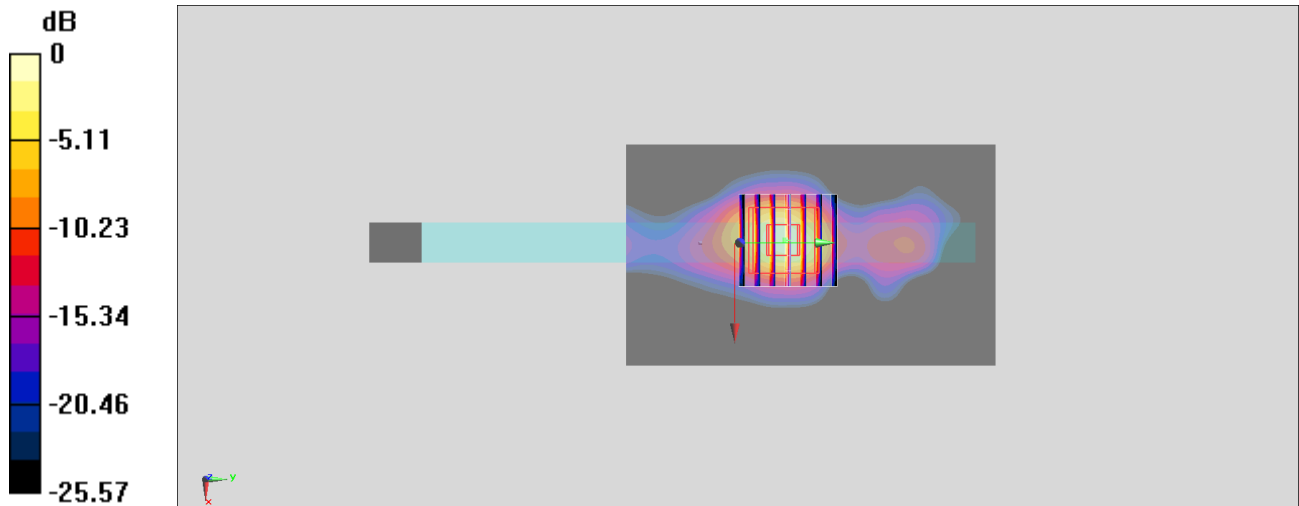

0 dB = 0.818 W/kg = -0.87 dBW/kg