



FCC RADIO TEST REPORT

FCC ID : 2ABVH-INARI10B2
Equipment : Tablet
Brand Name : AAVA
Model Name : INARI10B-LTG-1
Applicant : Aava Mobile Oy
NAHKATEHTAANKATU 2 90130
OULU FINLAND
Manufacturer : Aava Mobile Oy
NAHKATEHTAANKATU 2 90130
OULU FINLAND
Standard : FCC Part 15 Subpart C §15.247

The product was received on Jun. 06, 2019 and testing was started from Jul. 10, 2019 and completed on Jul. 16, 2019. We, SPORTON INTERNATIONAL INC., EMC & Wireless Communications Laboratory, would like to declare that the tested sample has been evaluated in accordance with the test procedures and has been in compliance with the applicable technical standards.

The report must not be used by the client to claim product certification, approval, or endorsement by TAF or any agency of government.

The test results in this variant report apply exclusively to the tested model / sample. Without written approval of SPORTON INTERNATIONAL INC. EMC & Wireless Communications Laboratory, the test report shall not be reproduced except in full.

Approved by: Jones Tsai

SPORTON INTERNATIONAL INC. EMC & Wireless Communications Laboratory

No. 52, Huaya 1st Rd., Guishan Dist., Taoyuan City, Taiwan (R.O.C.)



Table of Contents

History of this test report.....	3
Summary of Test Result.....	4
1 General Description	5
1.1 Product Feature of Equipment Under Test.....	5
1.2 Product Specification of Equipment Under Test.....	6
1.3 Modification of EUT	6
1.4 Testing Location	7
1.5 Applicable Standards.....	7
2 Test Configuration of Equipment Under Test	8
2.1 Carrier Frequency and Channel	8
2.2 Test Mode.....	9
2.3 Connection Diagram of Test System.....	14
2.4 EUT Operation Test Setup	14
3 Test Result	15
3.1 Output Power Measurement.....	15
3.2 Radiated Band Edges and Spurious Emission Measurement	18
3.3 Antenna Requirements	21
4 List of Measuring Equipment.....	22
5 Uncertainty of Evaluation	24
Appendix A. Radiated Spurious Emission	
Appendix B. Radiated Spurious Emission Plots	
Appendix C. Duty Cycle Plots	
Appendix D. Setup Photographs	
Appendix E. Original Report	



History of this test report

Report No.	Version	Description	Issued Date
FR960640C	01	Initial issue of report	Jul. 30, 2019



Summary of Test Result

Report Clause	Ref Std. Clause	Test Items	Result (PASS/FAIL)	Remark
-	15.247(a)(2)	6dB Bandwidth	Not Required	-
-	2.1049	99% Occupied Bandwidth	Not Required	-
3.1	15.247(b)	Power Output Measurement	Pass	-
-	15.247(e)	Power Spectral Density	Not Required	-
-	15.247(d)	Conducted Band Edges	Not Required	-
		Conducted Spurious Emission	Not Required	-
3.2	15.247(d)	Radiated Band Edges and Radiated Spurious Emission	Pass	Under limit 7.86 dB at 2389.590 MHz
-	15.207	AC Conducted Emission	Not Required	-
3.3	15.203 & 15.247(b)	Antenna Requirement	Pass	-

Remark:

1. Not required means after assessing, test items are not necessary to carry out.
2. This is a variant report by adding WWAN module. All the test cases were performed on original report which can be referred to Sporton Report Number FR910212C as appendix E. Based on the original report, the test cases were verified.

Declaration of Conformity:

The test results with all measurement uncertainty excluded are presented in accordance with the regulation limits or requirements declared by manufacturers.

Comments and Explanations:

The declared of product specification for EUT presented in the report are provided by the manufacturer, and the manufacturer takes all the responsibilities for the accuracy of product specification.

Reviewed by: Wii Chang

Report Producer: Ann Lee



1 General Description

1.1 Product Feature of Equipment Under Test

Product Feature	
Equipment	Tablet
Brand Name	AAVA
Model Name	INARI10B-LTG-1
FCC ID	2ABVH-INARI10B2
EUT supports Radios application	WCDMA/HSPA/LTE/NFC/GNSS WLAN 11a/b/g/n HT20/HT40 WLAN 11ac VHT20/VHT40/VHT80 Bluetooth BR/EDR/LE
HW Version	RU
SW Version	Windows 10
EUT Stage	Identical Prototype

Remark: The above EUT's information was declared by manufacturer.

Specification of Accessories				
AC Adapter	Brand Name	PHIHONG	Model Name	AQ18A-59CFA
Battery	Brand Name	Etica Battery	Model Name	AMME3950
USB Cable	Brand Name	PHIHONG	Model Name	UES-1001A160-R

1.2 Product Specification of Equipment Under Test

Standards-related Product Specification										
Tx/Rx Channel Frequency Range	2412 MHz ~ 2462 MHz									
Maximum Output Power to antenna	<p><Ant 1> 802.11b : 16.19 dBm (0.0416 W) 802.11g : 19.14 dBm (0.0820 W) 802.11n HT20 : 19.24 dBm (0.0839 W) 802.11n HT40 : 18.55 dBm (0.0716 W)</p> <p><Ant 2> 802.11b : 15.72 dBm (0.0373 W) 802.11g : 18.89 dBm (0.0774 W) 802.11n HT20 : 18.91 dBm (0.0778 W) 802.11n HT40 : 17.89 dBm (0.0615 W)</p> <p>MIMO <Ant. 1 + 2> 802.11b : 19.00 dBm (0.0794 W) 802.11g : 22.09 dBm (0.1618 W) 802.11n HT20 : 22.03 dBm (0.1596 W) 802.11n HT40 : 21.10 dBm (0.1288 W)</p>									
Antenna Type / Gain	<p><Ant. 1> Ceramic Antenna with gain 2.0 dBi <Ant. 2> Ceramic Antenna with gain 1.0 dBi</p>									
Type of Modulation	802.11b : DSSS (DBPSK / DQPSK / CCK) 802.11g/n : OFDM (BPSK / QPSK / 16QAM / 64QAM)									
Antenna Function for Transmitter	<table border="1"> <thead> <tr> <th></th> <th>Ant. 1</th> <th>Ant. 2</th> </tr> </thead> <tbody> <tr> <td>802.11 b/g/n</td> <td>V</td> <td>V</td> </tr> <tr> <td>802.11 b/g/n MIMO</td> <td>V</td> <td>V</td> </tr> </tbody> </table>		Ant. 1	Ant. 2	802.11 b/g/n	V	V	802.11 b/g/n MIMO	V	V
	Ant. 1	Ant. 2								
802.11 b/g/n	V	V								
802.11 b/g/n MIMO	V	V								

Note: MIMO Ant. 1+2 is a calculated result from sum of the power MIMO Ant. 1 and MIMO Ant. 2.

1.3 Modification of EUT

No modifications are made to the EUT during all test items.



1.4 Testing Location

Test Site	SPORTON INTERNATIONAL INC. EMC & Wireless Communications Laboratory	
Test Site Location	No.52, Huaya 1st Rd., Guishan Dist., Taoyuan City, Taiwan (R.O.C.) TEL: +886-3-327-3456 FAX: +886-3-328-4978	
Test Site No.	Sporton Site No.	
	TH05-HY	03CH07-HY

Note: The test site complies with ANSI C63.4 2014 requirement.

FCC designation No.: TW1190

1.5 Applicable Standards

According to the specifications of the manufacturer, the EUT must comply with the requirements of the following standards:

- ♦ FCC Part 15 Subpart C §15.247
- ♦ FCC KDB Publication No. 558074 D01 DTS Meas. Guidance v05r02
- ♦ FCC KDB 414788 D01 Radiated Test Site v01r01.
- ♦ FCC KDB 662911 D01 Multiple Transmitter Output v02r01.
- ♦ ANSI C63.10-2013

Remark:

1. All test items were verified and recorded according to the standards and without any deviation during the test.
2. This EUT has also been tested and complied with the requirements of FCC Part 15, Subpart B, recorded in a separate test report.



2 Test Configuration of Equipment Under Test

- a. The EUT has been associated with peripherals and configuration operated in a manner tended to maximize its emission characteristics in a typical application. Frequency range investigated:, radiation emission (9 kHz to the 10th harmonic of the highest fundamental frequency or to 40 GHz, whichever is lower). For radiated measurement, pre-scanned in three orthogonal panels, X, Y, Z. The worst cases (X plane) were recorded in this report.

2.1 Carrier Frequency and Channel

Frequency Band	Channel	Freq. (MHz)	Channel	Freq. (MHz)
2400-2483.5 MHz	1	2412	7	2442
	2	2417	8	2447
	3	2422	9	2452
	4	2427	10	2457
	5	2432	11	2462
	6	2437		



2.2 Test Mode

<Ant. 1>

802.11b RF Peak Output Power (dBm)		
Power vs. Channel		
Channel	Frequency (MHz)	Data Rate (bps)
		1M
CH 01	2412	16.19

802.11g RF Peak Output Power (dBm)		
Power vs. Channel		
Channel	Frequency (MHz)	Data Rate (bps)
		6M
CH 01	2412	19.14

802.11n HT20 RF Peak Output Power (dBm)		
Power vs. Channel		
Channel	Frequency (MHz)	MCS Index
		MCS 0
CH 01	2412	19.24

802.11n HT40 RF Peak Output Power (dBm)		
Power vs. Channel		
Channel	Frequency (MHz)	MCS Index
		MCS 0
CH 03	2422	18.55

<ANT 2>

802.11b RF Peak Output Power (dBm)		
Power vs. Channel		
Channel	Frequency (MHz)	Data Rate (bps)
		1M
CH 01	2412	15.72



802.11g RF Peak Output Power (dBm)		
Power vs. Channel		
Channel	Frequency (MHz)	Data Rate (bps)
		6M
CH 01	2412	18.89

802.11n HT20 RF Peak Output Power (dBm)		
Power vs. Channel		
Channel	Frequency (MHz)	MCS Index
		MCS 0
CH 01	2412	18.91

802.11n HT40 RF Peak Output Power (dBm)		
Power vs. Channel		
Channel	Frequency (MHz)	MCS Index
		MCS 0
CH 03	2422	17.89

<ANT 1+2>

802.11b RF Peak Output Power (dBm)		
Power vs. Channel		
Channel	Frequency (MHz)	Data Rate (bps)
		1M
CH 01	2412	19.00

802.11g RF Peak Output Power (dBm)		
Power vs. Channel		
Channel	Frequency (MHz)	Data Rate (bps)
		6M
CH 01	2412	22.09



802.11n HT20 RF Peak Output Power (dBm)		
Power vs. Channel		
Channel	Frequency (MHz)	MCS Index
		MCS0
CH 01	2412	22.03

802.11n HT40 RF Peak Output Power (dBm)		
Power vs. Channel		
Channel	Frequency (MHz)	MCS Index
		MCS0
CH 03	2422	21.10

<Ant. 1>

802.11b RF Average Output Power (dBm)		
Power vs. Channel		
Channel	Frequency (MHz)	Data Rate (bps)
		1M
CH 01	2412	13.60

802.11g RF Average Output Power (dBm)		
Power vs. Channel		
Channel	Frequency (MHz)	Data Rate (bps)
		6M
CH 01	2412	13.64

802.11n HT20 RF Average Output Power (dBm)		
Power vs. Channel		
Channel	Frequency (MHz)	MCS Index
		MCS 0
CH 01	2412	13.69



802.11n HT40 RF Average Output Power (dBm)		
Power vs. Channel		
Channel	Frequency (MHz)	MCS Index
		MCS 0
CH 03	2422	14.07

<Ant. 2>

802.11b RF Average Output Power (dBm)		
Power vs. Channel		
Channel	Frequency (MHz)	Data Rate (bps)
		1M
CH 01	2412	13.24

802.11g RF Average Output Power (dBm)		
Power vs. Channel		
Channel	Frequency (MHz)	Data Rate (bps)
		6M
CH 01	2412	13.42

802.11n HT20 RF Average Output Power (dBm)		
Power vs. Channel		
Channel	Frequency (MHz)	MCS Index
		MCS 0
CH 01	2412	13.27

802.11n HT40 RF Average Output Power (dBm)		
Power vs. Channel		
Channel	Frequency (MHz)	MCS Index
		MCS 0
CH 03	2422	13.46



<ANT 1+2>

802.11b RF Average Output Power (dBm)		
Power vs. Channel		
Channel	Frequency (MHz)	Data Rate (bps)
		1M
CH 01	2412	16.41

802.11g RF Average Output Power (dBm)		
Power vs. Channel		
Channel	Frequency (MHz)	Data Rate (bps)
		6M
CH 01	2412	16.57

802.11n HT20 RF Average Output Power (dBm)		
Power vs. Channel		
Channel	Frequency (MHz)	MCS Index
		MCS0
CH 01	2412	16.48

802.11n HT40 RF Output Power (dBm)		
Power vs. Channel		
Channel	Frequency (MHz)	MCS Index
		MCS0
CH 03	2422	16.61

2.3 Connection Diagram of Test System

<WLAN Tx Mode>

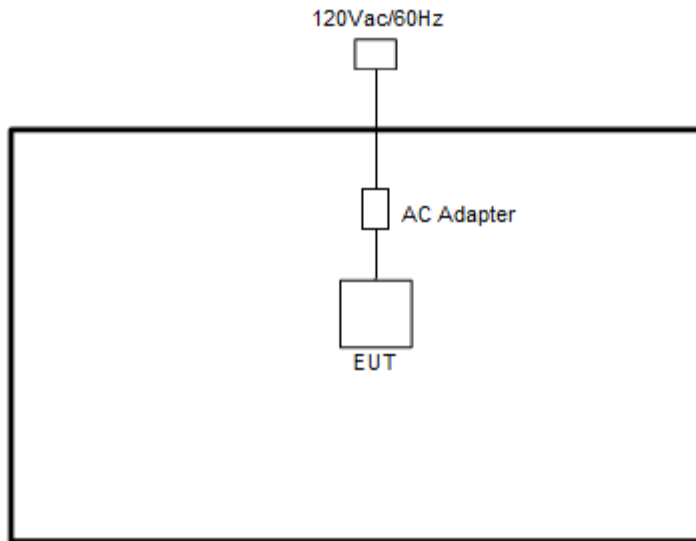

2.4 EUT Operation Test Setup

The RF test items, utility “DRTU version 11.1803.0-06808” was installed in EUT which was programmed in order to make the EUT get into the engineering modes to provide channel selection, power level, data rate and the application type and for continuous transmitting signals.

The EUT was set to connect with the WLAN AP under large packet of transmission.

3 Test Result

3.1 Output Power Measurement

3.1.1 Limit of Output Power

For systems using digital modulation in the 2400-2483.5MHz, the limit for peak output power is 30dBm. If transmitting antenna with directional gain greater than 6dBi is used, the peak output power from the intentional radiator shall be reduced below the above stated value by the amount in dB that the directional gain of the antenna exceeds 6 dBi. In case of point-to-point operation, the limit has to be reduced by 1dB for every 3dB that the directional gain of the antenna exceeds 6dBi.

3.1.2 Measuring Instruments

See list of measuring equipment of this test report.

3.1.3 Test Procedures

1. For Peak Power, the testing follows ANSI C63.10 Section 11.9.1.3 PKPM1
2. For Average Power, the testing follows ANSI C63.10 Section 11.9.2.3.1 Method AVGPM
3. The RF output of EUT was connected to the power meter by RF cable and attenuator. The path loss was compensated to the results for each measurement.
4. Set to the maximum power setting and enable the EUT transmit continuously.
5. Measure the conducted output power and record the results in the test report.
6. For MIMO mode, calculation method follows FCC KDB 662911 D01 Multiple Transmitter Output v02r01.

3.1.4 Test Setup

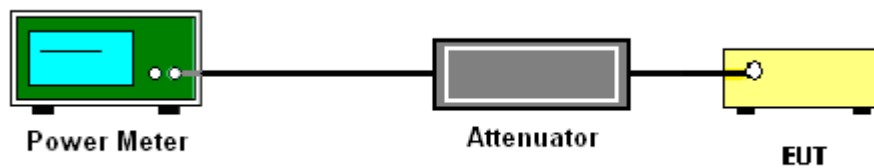



3.1.5 Test Result of Peak Output Power

Test Engineer :	CreedWu	Temperature :	21~25°C
		Relative Humidity :	51~54%

2.4GHz Band																
Mod.	Data Rate	NTX	CH.	Freq. (MHz)	Peak Conducted Power (dBm)			Conducted Power Limit (dBm)		DG (dBi)		EIRP Power (dBm)		EIRP Power Limit (dBm)		Pass /Fail
					Ant 1	Ant 2	SUM	Ant 1	Ant 2	Ant 1	Ant 2	Ant 1	Ant 2	Ant 1	Ant 2	
11b	1Mbps	1	1	2412	16.19	15.72	-	30.00	30.00	2.00	1.00	18.19	16.72	36.00	36.00	Pass
11g	6Mbps	1	1	2412	19.14	18.89	-	30.00	30.00	2.00	1.00	21.14	19.89	36.00	36.00	Pass
HT20	MCS0	1	1	2412	19.24	18.91	-	30.00	30.00	2.00	1.00	21.24	19.91	36.00	36.00	Pass
HT40	MCS0	1	3	2422	18.55	17.89	-	30.00	30.00	2.00	1.00	20.55	18.89	36.00	36.00	Pass
11b	1Mbps	2	1	2412	16.10	15.87	19.00	30.00		2.00		21.00		36.00		Pass
11g	6Mbps	2	1	2412	19.21	18.94	22.09	30.00		2.00		24.09		36.00		Pass
HT20	MCS0	2	1	2412	19.19	18.85	22.03	30.00		2.00		24.03		36.00		Pass
HT40	MCS0	2	3	2422	18.24	17.93	21.10	30.00		2.00		23.10		36.00		Pass



3.1.6 Test Result of Average Output Power (Reporting Only)

Test Engineer :	CreedWu	Temperature :	21~25°C
		Relative Humidity :	51~54%

2.4GHz Band									
Mod.	Data Rate	NTX	CH.	Freq. (MHz)	Duty Factor (dB)		Average Conducted Power (dBm)		
					Ant 1	Ant 2	Ant 1	Ant 2	SUM
11b	1Mbps	1	1	2412	0.05	0.05	13.60	13.24	-
11g	6Mbps	1	1	2412	0.06	0.06	13.64	13.42	
HT20	MCS0	1	1	2412	0.06	0.06	13.69	13.27	
HT40	MCS0	1	3	2422	0.16	0.14	14.07	13.46	
11b	1Mbps	2	1	2412	0.04	0.04	13.45	13.35	16.41
11g	6Mbps	2	1	2412	0.07	0.07	13.72	13.40	16.57
HT20	MCS0	2	1	2412	0.08	0.08	13.62	13.32	16.48
HT40	MCS0	2	3	2422	0.16	0.16	13.77	13.43	16.61



3.2 Radiated Band Edges and Spurious Emission Measurement

3.2.1 Limit of Radiated band edge and Spurious Emission Measurement

In any 100 kHz bandwidth outside the intentional radiator frequency band, all harmonics/spurious must be at least 20 dB below the highest emission level within the authorized band. If the output power of this device was measured by spectrum analyzer, the attenuation under this paragraph shall be 30 dB instead of 20 dB. In addition, radiated emissions which fall in the restricted bands must also comply with the limits as below.

Frequency (MHz)	Field Strength (microvolts/meter)	Measurement Distance (meters)
0.009 – 0.490	2400/F(kHz)	300
0.490 – 1.705	24000/F(kHz)	30
1.705 – 30.0	30	30
30 – 88	100	3
88 – 216	150	3
216 - 960	200	3
Above 960	500	3

3.2.2 Measuring Instruments

See list of measuring equipment of this test report.



3.2.3 Test Procedures

1. The testing follows the ANSI C63.10 Section 11.12.1 Radiated emission measurements.
2. The EUT was arranged to its worst case and then tune the antenna tower (from 1 m to 4 m) and turntable (from 0 degree to 360 degrees) to find the maximum reading. A pre-amp and a high pass filter are used for the test in order to get better signal level.
3. The EUT was placed on a turntable with 0.8 meter for frequency below 1GHz and 1.5 meter for frequency above 1GHz respectively above ground.
4. The EUT was set 3 meters from the interference receiving antenna, which was mounted on the top of a variable height antenna tower.
5. Corrected Reading: Antenna Factor + Cable Loss + Read Level - Preamp Factor = Level
6. For testing below 1GHz, if the emission level of the EUT in peak mode was 3 dB lower than the limit specified, then peak values of EUT will be reported, otherwise, the emissions will be repeated one by one using the CISPR quasi-peak method and reported.
7. For testing above 1GHz, the emission level of the EUT in peak mode was 20dB lower than average limit (that means the emission level in average mode also complies with the limit in average mode), then peak values of EUT will be reported, otherwise, the emissions will be measured in average mode again and reported.
8. Use the following spectrum analyzer settings:
 - (1) Span shall wide enough to fully capture the emission being measured;
 - (2) Set RBW= 1 MHz, VBW= 3MHz for $f \geq 1$ GHz; Sweep = auto; Detector function = peak; Trace = max hold for peak measurement.
For average measurement:
 - VBW = 10 Hz, when duty cycle is no less than 98 percent.
 - $VBW \geq 1/T$, when duty cycle is less than 98 percent where T is the minimum transmission duration over which the transmitter is on and is transmitting at its maximum power control level for the tested mode of operation.

3.2.4 Test Setup

For radiated emissions above 1GHz

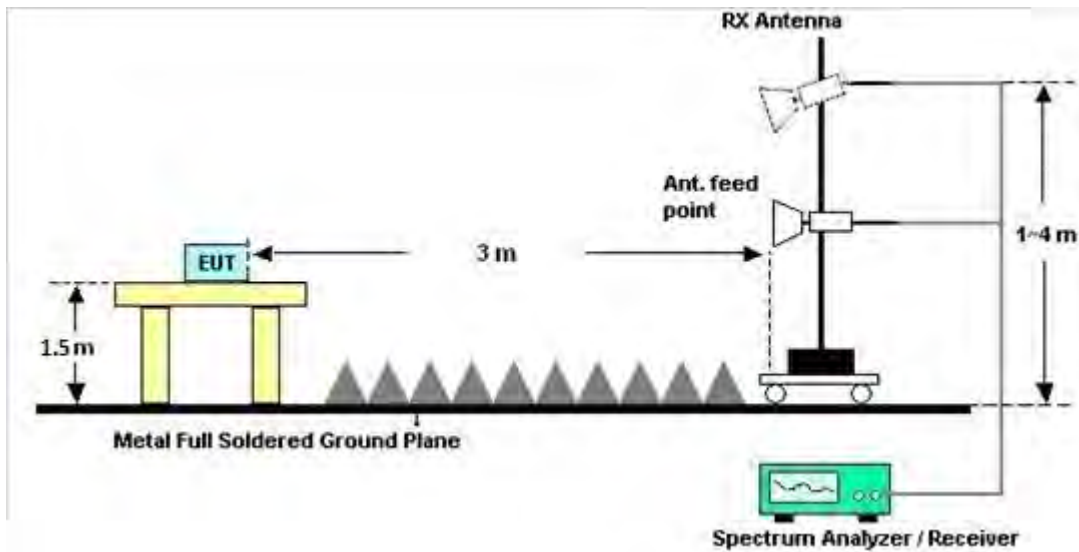

3.2.5 Test Result of Radiated Spurious at Band Edges

Please refer to Appendix A and B.

3.2.6 Duty Cycle

Please refer to Appendix C.

3.2.7 Test Result of Radiated Spurious Emission (Harmonic)

Please refer to Appendix A and B.



3.3 Antenna Requirements

3.3.1 Standard Applicable

If directional gain of transmitting Antennas is greater than 6dBi, the power shall be reduced by the same level in dB comparing to gain minus 6dBi. The use of a permanently attached Antenna or of an Antenna that uses a unique coupling to the intentional radiator shall be considered sufficient to comply with the rule.

3.3.2 Antenna Anti-Replacement Construction

An embedded-in antenna design is used.

3.3.3 Antenna Gain

<CDD Modes >

FCC KDB 662911 D01 Multiple Transmitter Output v02r01

For CDD transmissions, directional gain is calculated as

Directional gain = G_{ANT} + Array Gain, where Array Gain is as follows.

For power spectral density (PSD) measurements on all devices,

Array Gain = $10 \log(N_{ANT}/N_{SS}=1)$ dB.

For power measurements on IEEE 802.11 devices,

Array Gain = 0 dB (i.e., no array gain) for $N_{ANT} \leq 4$.

Directional gain may be calculated by using the formulas applicable to equal gain antennas with G_{ANT} set equal to the gain of the antenna having the highest gain;

The EUT supports CDD mode.

For power, the directional gain G_{ANT} is set equal to the antenna having the highest gain, i.e., F)2)f)i).

For PSD, the directional gain calculation is following F)2)f)ii) of KDB 662911 D01 v02r01.

The power and PSD limit should be modified if the directional gain of EUT is over 6 dBi,

The directional gain "DG" is calculated as following table.

<CDD Modes>						
			DG for Power (dBi)	DG for PSD (dBi)	Power Limit Reduction (dB)	PSD Limit Reduction (dB)
	Ant. 1 (dBi)	Ant. 2 (dBi)				
2.4 GHz	2.00	1.00	4.52	4.52	0.00	0.00

$Power\ Limit\ Reduction = DG(Power) - 6dBi, (min = 0)$

$PSD\ Limit\ Reduction = DG(PSD) - 6dBi, (min = 0)$



4 List of Measuring Equipment

Instrument	Manufacturer	Model No.	Serial No.	Characteristics	Calibration Date	Test Date	Due Date	Remark
Power Sensor	DARE	RPR3006W	13I00030S NO32	9kHz~6GHz	Dec. 03, 2018	Jul. 10, 2019	Dec. 02, 2019	Conducted (TH05-HY)
Spectrum Analyzer	Rohde & Schwarz	FSP40	100057	9kHz~40GHz	Nov. 21, 2018	Jul. 10, 2019	Nov. 20, 2019	Conducted (TH05-HY)
Switch Box & RF Cable	Burgeon	ETF-058	EC120838 2	N/A	Mar. 27, 2019	Jul. 10, 2019	Mar. 26, 2020	Conducted (TH05-HY)
Bilog Antenna	TESEQ	CBL 6111D & 00800N1D01 N-06	35419 & 03	30MHz~1GHz	Apr. 30, 2019	Jul. 15, 2019 ~ Jul. 16, 2019	Apr. 29, 2020	Radiation (03CH07-HY)
Double Ridge Horn Antenna	ESCO	3117	00075962	1GHz ~ 18GHz	Dec. 02, 2018	Jul. 15, 2019 ~ Jul. 16, 2019	Dec. 03, 2019	Radiation (03CH07-HY)
EMI Test Receiver	Agilent	N9038A(MXE)	MY532900 53	20Hz~26.5GHz	Jan. 23, 2019	Jul. 15, 2019 ~ Jul. 16, 2019	Jan. 22, 2020	Radiation (03CH07-HY)
Loop Antenna	Rohde & Schwarz	HFH2-Z2	100315	9 kHz~30 MHz	Jan. 11, 2019	Jul. 15, 2019 ~ Jul. 16, 2019	Jan. 10, 2020	Radiation (03CH07-HY)
Preamplifier	MITEQ	AMF-7D-0010 1800-30-10P	1590075	1GHz~18GHz	Apr. 24, 2019	Jul. 15, 2019 ~ Jul. 16, 2019	Apr. 23, 2020	Radiation (03CH07-HY)
Preamplifier	COM-POWER	PA-103A	161241	10MHz~1GHz	May 20, 2019	Jul. 15, 2019 ~ Jul. 16, 2019	May 19, 2020	Radiation (03CH07-HY)
Preamplifier	Agilent	8449B	3008A023 62	1GHz~26.5GHz	Nov. 02, 2018	Jul. 15, 2019 ~ Jul. 16, 2019	Nov. 01, 2019	Radiation (03CH07-HY)
Filter	Microwave	H1G013G1	SN477215	1GHz High Pass Filter	Nov. 02, 2018	Jul. 15, 2019 ~ Jul. 16, 2019	Nov. 01, 2019	Radiation (03CH07-HY)
Filter	Wainwright	WLKS1200-8 SS	SN3	1.2GHz Low Pass Filter	Nov. 02, 2018	Jul. 15, 2019 ~ Jul. 16, 2019	Nov. 01, 2019	Radiation (03CH07-HY)
Filter	Microwave	H3G018G1	SN477220	3GHz High Pass Filter	Nov. 02, 2018	Jul. 15, 2019 ~ Jul. 16, 2019	Nov. 01, 2019	Radiation (03CH07-HY)



Instrument	Manufacturer	Model No.	Serial No.	Characteristics	Calibration Date	Test Date	Due Date	Remark
RF Cable	HUBER + SUHNER	SUCOFLEX 104	MY24971/4, MY28655/4	9kHz~30MHz	Feb. 26, 2019	Jul. 15, 2019 ~ Jul. 16, 2019	Feb. 25, 2020	Radiation (03CH07-HY)
RF Cable	HUBER + SUHNER	SUCOFLEX 104	MY28655/4, MY24971/4, MY15682/4	30MHz~1GHz	Feb. 26, 2019	Jul. 15, 2019 ~ Jul. 16, 2019	Feb. 25, 2020	Radiation (03CH07-HY)
RF Cable	HUBER + SUHNER	SUCOFLEX 104	MY28655/4, MY24971/4, MY15682/4	1GHz~18GHz	Feb. 26, 2019	Jul. 15, 2019 ~ Jul. 16, 2019	Feb. 25, 2020	Radiation (03CH07-HY)
RF Cable	HUBER + SUHNER	SUCOFLEX 102	MY2858/2	18GHz~40GHz	Feb. 26, 2019	Jul. 15, 2019 ~ Jul. 16, 2019	Feb. 25, 2020	Radiation (03CH07-HY)
Antenna Mast	Max-Full	MFA520BS	N/A	1m~4m	N/A	Jul. 15, 2019 ~ Jul. 16, 2019	N/A	Radiation (03CH07-HY)
Turn Table	ChainTek	Chaintek 3000	N/A	0~360 Degree	N/A	Jul. 15, 2019 ~ Jul. 16, 2019	N/A	Radiation (03CH07-HY)
Preamplifier	MITEQ	TTA1840-35-H G	1871923	18GHz~40GHz, VSWR : 2.5:1 max	N/A	Jul. 15, 2019 ~ Jul. 16, 2019	N/A	Radiation (03CH07-HY)
SHF-EHF Horn Antenna	SCHWARZBECK	BBHA 9170	BBHA917025 1	18GHz~40GHz	Nov. 20, 2018	Jul. 15, 2019 ~ Jul. 16, 2019	Nov. 19, 2019	Radiation (03CH07-HY)
Spectrum Analyzer	Agilent	N9010A	MY53470118	10Hz~44GHz	Apr. 18, 2019	Jul. 15, 2019 ~ Jul. 16, 2019	Apr. 17, 2020	Radiation (03CH07-HY)
Software	Audix	E3 6.2009-8-24	8050400465 6H	N/A	N/A		N/A	Radiation (03CH07-HY)



5 Uncertainty of Evaluation

Uncertainty of Radiated Emission Measurement (30 MHz ~ 1000 MHz)

Measuring Uncertainty for a Level of Confidence of 95% ($U = 2Uc(y)$)	5.7
---	-----

Uncertainty of Radiated Emission Measurement (1000 MHz ~ 18000 MHz)

Measuring Uncertainty for a Level of Confidence of 95% ($U = 2Uc(y)$)	5.5
---	-----

Uncertainty of Radiated Emission Measurement (18000 MHz ~ 40000 MHz)

Measuring Uncertainty for a Level of Confidence of 95% ($U = 2Uc(y)$)	5.2
---	-----



Appendix A. Radiated Spurious Emission

Test Engineer :	Stan Hsieh and KenWu	Temperature :	28.2~28.3°C
		Relative Humidity :	50~53%

2.4GHz 2400~2483.5MHz

WIFI 802.11g (Band Edge @ 3m)

WIFI Ant.	Note	Frequency (MHz)	Level (dBμV/m)	Over Limit (dB)	Limit Line (dBμV/m)	Read Level (dBμV)	Antenna Factor (dB/m)	Path Loss (dB)	Preamp Factor (dB)	Ant Pos (cm)	Table Pos (deg)	Peak Avg. (P/A)	Pol. (H/V)	
802.11g CH 01 2412MHz		2388.435	56.41	-17.59	74	41.61	32	17.74	34.94	104	299	P	H	
		2389.59	46.14	-7.86	54	31.34	32	17.74	34.94	104	299	A	H	
	*	2412	112.7	-	-	97.84	32.07	17.74	34.95	104	299	P	H	
	*	2412	105.15	-	-	90.29	32.07	17.74	34.95	104	299	A	H	
													H	
														H
			2362.605	55.89	-18.11	74	41.29	31.87	17.67	34.94	400	5	P	V
			2390	45.3	-8.7	54	30.51	32	17.74	34.95	400	5	A	V
	*		2412	113.89	-	-	99.03	32.07	17.74	34.95	400	5	P	V
	*		2412	105.05	-	-	90.19	32.07	17.74	34.95	400	5	A	V
														V
														V
Remark	1. No other spurious found. 2. All results are PASS against Peak and Average limit line.													



2.4GHz 2400~2483.5MHz

WIFI 802.11g (Harmonic @ 3m)

WIFI Ant. 1+2	Note	Frequency (MHz)	Level (dBμV/m)	Over Limit (dB)	Limit Line (dBμV/m)	Read Level (dBμV)	Antenna Factor (dB/m)	Path Loss (dB)	Preamp Factor (dB)	Ant Pos (cm)	Table Pos (deg)	Peak Avg. (P/A)	Pol. (H/V)	
802.11g CH 01 2412MHz		4824	50.26	-23.74	74	63.8	34.1	11.39	59.03	100	260	P	H	
													H	
													H	
													H	
			4824	40.36	-13.64	54	53.9	34.1	11.39	59.03	100	260	A	H
			4824	45.49	-28.51	74	59.03	34.1	11.39	59.03	100	0	P	V
														V
Remark	1. No other spurious found.													
	2. All results are PASS against Peak and Average limit line.													



2.4GHz 2400~2483.5MHz

Note symbol

*	Fundamental Frequency which can be ignored. However, the level of any unwanted emissions shall not exceed the level of the fundamental frequency.
!	Test result is over limit line.
P/A	Peak or Average
H/V	Horizontal or Vertical



A calculation example for radiated spurious emission is shown as below:

WIFI	Note	Frequency	Level	Over	Limit	Read	Antenna	Path	Preamp	Ant	Table	Peak	Pol.
Ant.				Limit	Line	Level	Factor	Loss	Factor	Pos	Pos	Avg.	
1+2		(MHz)	(dBμV/m)	(dB)	(dBμV/m)	(dBμV)	(dB/m)	(dB)	(dB)	(cm)	(deg)	(P/A)	(H/V)
802.11b		2390	55.45	-18.55	74	54.51	32.22	4.58	35.86	103	308	P	H
CH 01													
2412MHz		2390	43.54	-10.46	54	42.6	32.22	4.58	35.86	103	308	A	H

1. Path Loss(dB) = Cable loss(dB) + Filter loss(dB) + Attenuator loss(dB)
2. Level(dBμV/m) =
Antenna Factor(dB/m) + Path Loss(dB) + Read Level(dBμV) - Preamp Factor(dB)
3. Over Limit(dB) = Level(dBμV/m) – Limit Line(dBμV/m)

For Peak Limit @ 2390MHz:

1. Level(dBμV/m)
= Antenna Factor(dB/m) + Path Loss(dB) + Read Level(dBμV) - Preamp Factor(dB)
= 32.22(dB/m) + 4.58(dB) + 54.51(dBμV) – 35.86 (dB)
= 55.45 (dBμV/m)
2. Over Limit(dB)
= Level(dBμV/m) – Limit Line(dBμV/m)
= 55.45(dBμV/m) – 74(dBμV/m)
= -18.55(dB)

For Average Limit @ 2390MHz:

1. Level(dBμV/m)
= Antenna Factor(dB/m) + Path Loss(dB) + Read Level(dBμV) - Preamp Factor(dB)
= 32.22(dB/m) + 4.58(dB) + 42.6(dBμV) – 35.86 (dB)
= 43.54 (dBμV/m)
2. Over Limit(dB)
= Level(dBμV/m) – Limit Line(dBμV/m)
= 43.54(dBμV/m) – 54(dBμV/m)
= -10.46(dB)

Both peak and average measured complies with the limit line, so test result is “PASS”.



Appendix B. Radiated Spurious Emission Plots

Test Engineer :	Stan Hsieh and KenWu	Temperature :	28.2~28.3°C
		Relative Humidity :	50~53%

Note symbol

-L	Low channel location
-R	High channel location



2.4GHz 2400~2483.5MHz
WIFI 802.11g (Band Edge @ 3m)

WIFI	2.4GHz 2400~2483.5MHz Band Edge @ 3m	
ANT	802.11g CH01 2412MHz	
1+2	Horizontal	Fundamental
Peak	<p>Site : 03CH07-HY Condition : 1 PEAK_BE_74 3m HE_ANT_00075962 HORIZONTAL 1 RBW:1000.000kHz VBW:3000.000kHz SWT:Auto Detector : Peak Project : 962046 Mode : 3 Setting : 13.5/12.5</p>	<p>Site : 03CH07-HY Condition : 1 PEAK_74 3m HE_ANT_00075962 HORIZONTAL 1 RBW:1000.000kHz VBW:3000.000kHz SWT:Auto Detector : Peak Project : 962046 Mode : 3 Setting : 13.5/12.5</p>
Avg.	<p>Site : 03CH07-HY Condition : 1 AVG_BE_54 3m HE_ANT_00075962 HORIZONTAL 1 RBW:1000.000kHz VBW:0.010kHz SWT:Auto Detector : Peak Project : 962046 Mode : 3 Setting : 13.5/12.5</p>	<p>Site : 03CH07-HY Condition : 1 AVG_54 3m HE_ANT_00075962 HORIZONTAL 1 RBW:1000.000kHz VBW:0.010kHz SWT:Auto Detector : Peak Project : 962046 Mode : 3 Setting : 13.5/12.5</p>

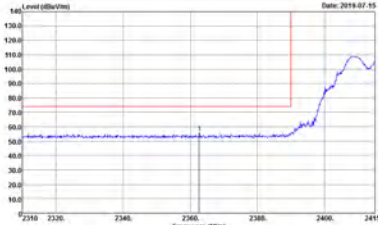
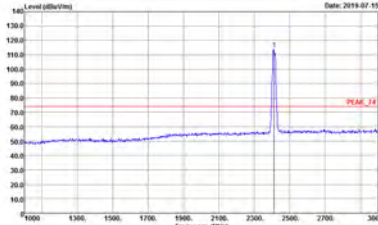
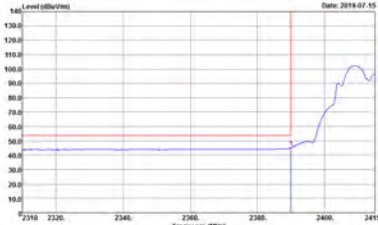
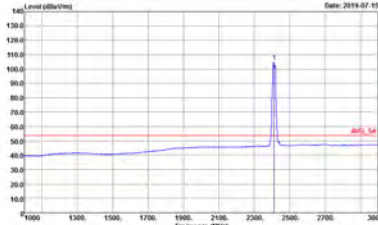

WIFI	2.4GHz 2400~2483.5MHz Band Edge @ 3m	
ANT	802.11g CH01 2412MHz	
1+2	Vertical	Fundamental
Peak	 <p>Site : 03CH07-HY Condition : PEAK_BE_74 3m HF_ANT_00075962 VERTICAL Detector : Peak Project : 962046 Mode : 3 Setting : 13.5/12.5</p>	 <p>Site : 03CH07-HY Condition : PEAK_74 3m HF_ANT_00075962 VERTICAL Detector : Peak Project : 962046 Mode : 3 Setting : 13.5/12.5</p>
Avg.	 <p>Site : 03CH07-HY Condition : AVG_BE_58 3m HF_ANT_00075962 VERTICAL Detector : Peak Project : 962046 Mode : 3 Setting : 13.5/12.5</p>	 <p>Site : 03CH07-HY Condition : AVG_58 3m HF_ANT_00075962 VERTICAL Detector : Peak Project : 962046 Mode : 3 Setting : 13.5/12.5</p>



2.4GHz 2400~2483.5MHz
WIFI 802.11g (Harmonic @ 3m)

Table with 2 columns: Horizontal and Vertical. Each column contains a spectrum plot showing Level (dBuV/m) vs Frequency (MHz) with peak markers and technical details like Site, Condition, and Detector.



Appendix C. Duty Cycle Plots

Antenna	Band	Duty Cycle(%)	T(us)	1/T(kHz)	VBW Setting	Duty Factor(dB)
1+2	802.11g for Ant. 1	98.32	2045	0.49	10Hz	0.07
1+2	802.11g for Ant. 2	98.32	2045	0.49	10Hz	0.07



MIMO <Ant. 1>

802.11g

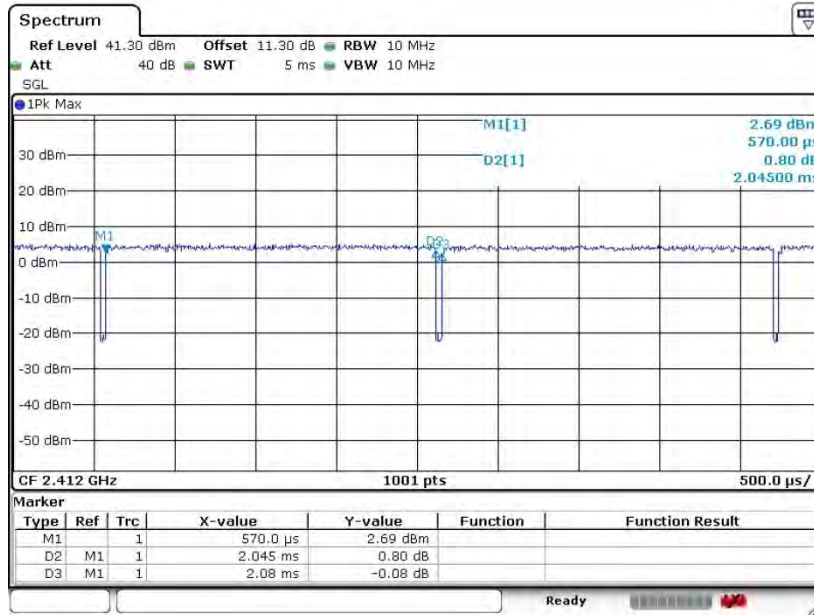

Date: 10, JUL. 2019 22:23:00

MIMO <Ant. 2>

802.11g

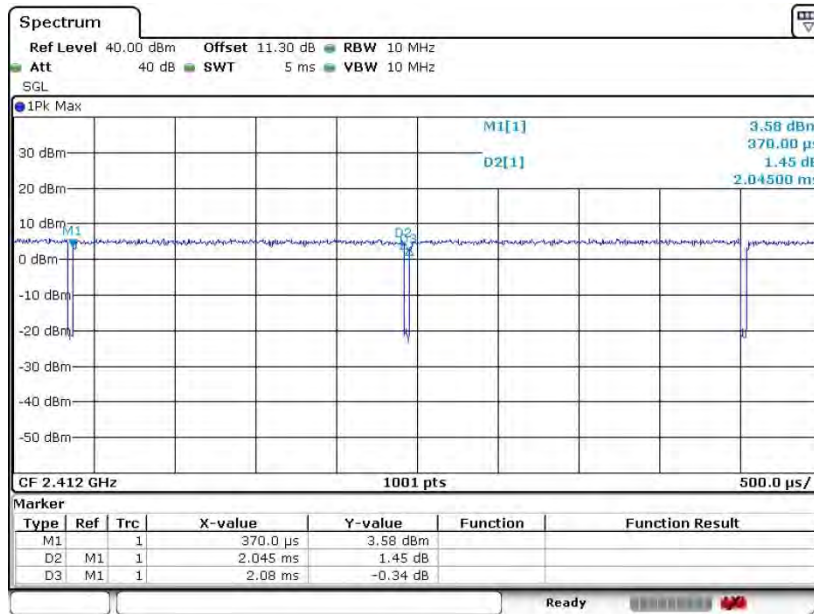

Date: 10, JUL. 2019 22:23:59



Appendix E Original Report

Please refer to Sporton report number FR910212C as below.



FCC RADIO TEST REPORT

FCC ID : 2ABVH-INARI10B1
Equipment : Tablet
Brand Name : AAVA
Model Name : INARI10B-WIG-1
Applicant : Aava Mobile Oy
NAHKATEHTAANKATU 2 90130 OULU FINLAND
Manufacturer : Aava Mobile Oy
NAHKATEHTAANKATU 2 90130 OULU FINLAND
Standard : FCC Part 15 Subpart C §15.247

The product was received on Dec. 24, 2018 and testing was started from Jan. 10, 2019 and completed on Jan. 23, 2019. We, SPORTON INTERNATIONAL INC. EMC & Wireless Communications Laboratory, would like to declare that the tested sample has been evaluated in accordance with the test procedures and has been in compliance with the applicable technical standards.

The report must not be used by the client to claim product certification, approval, or endorsement by TAF or any agency of government.

The test results in this report apply exclusively to the tested model / sample. Without written approval of SPORTON INTERNATIONAL INC. EMC & Wireless Communications Laboratory, the test report shall not be reproduced except in full.

Approved by: Jones Tsai

SPORTON INTERNATIONAL INC. EMC & Wireless Communications Laboratory

No. 52, Huaya 1st Rd., Guishan Dist., Taoyuan City, Taiwan (R.O.C.)



Table of Contents

History of this test report.....	3
Summary of Test Result.....	4
1 General Description	5
1.1 Product Feature of Equipment Under Test.....	5
1.2 Product Specification of Equipment Under Test.....	6
1.3 Modification of EUT	7
1.4 Testing Location	7
1.5 Applicable Standards.....	7
2 Test Configuration of Equipment Under Test	8
2.1 Carrier Frequency and Channel	8
2.2 Test Mode.....	9
2.3 Connection Diagram of Test System.....	16
2.4 Support Unit used in test configuration and system	17
2.5 EUT Operation Test Setup	17
2.6 Measurement Results Explanation Example.....	17
3 Test Result	18
3.1 6dB and 99% Bandwidth Measurement	18
3.2 Output Power Measurement.....	21
3.3 Power Spectral Density Measurement	24
3.4 Conducted Band Edges and Spurious Emission Measurement	27
3.5 Radiated Band Edges and Spurious Emission Measurement	76
3.6 AC Conducted Emission Measurement.....	80
3.7 Antenna Requirements	82
4 List of Measuring Equipment.....	83
5 Uncertainty of Evaluation	84
Appendix A. AC Conducted Emission Test Result	
Appendix B. Radiated Spurious Emission	
Appendix C. Radiated Spurious Emission Plots	
Appendix D. Duty Cycle Plots	
Appendix E. Setup Photographs	



Summary of Test Result

Report Clause	Ref Std. Clause	Test Items	Result (PASS/FAIL)	Remark
3.1	15.247(a)(2)	6dB Bandwidth	Pass	-
3.1	2.1049	99% Occupied Bandwidth	Reporting only	-
3.2	15.247(b)	Power Output Measurement	Pass	-
3.3	15.247(e)	Power Spectral Density	Pass	-
3.4	15.247(d)	Conducted Band Edges	Pass	-
		Conducted Spurious Emission	Pass	-
3.5	15.247(d)	Radiated Band Edges and Radiated Spurious Emission	Pass	Under limit 14.08 dB at 0.701 MHz
3.6	15.207	AC Conducted Emission	Pass	Under limit 3.04 dB at 2390.000 MHz
3.7	15.203 & 15.247(b)	Antenna Requirement	Pass	-

Declaration of Conformity:

The test results with all measurement uncertainty excluded are presented in accordance with the regulation limits or requirements declared by manufacturers.

Comments and Explanations:

The declared of product specification for EUT presented in the report are provided by the manufacturer, and the manufacturer takes all the responsibilities for the accuracy of product specification.

Reviewed by: Wii Chang

Report Producer: Maggie Chiang



1 General Description

1.1 Product Feature of Equipment Under Test

Product Feature	
Equipment	Tablet
Brand Name	AAVA
Model Name	INARI10B-WIG-1
FCC ID	2ABVH-INARI10B1
EUT supports Radios application	NFC/GNSS WLAN 11a/b/g/n HT20/HT40 WLAN 11ac VHT20/VHT40/VHT80 Bluetooth BR/EDR/LE
HW Version	DV1
SW Version	Windows 10
EUT Stage	Identical Prototype

Remark: The above EUT's information was declared by manufacturer..

Specification of Accessories				
AC Adapter	Brand Name	PHIHONG	Model Name	AQ18A-59CFA
Battery	Brand Name	Etica Battery	Model Name	AMME3950
USB Cable	Brand Name	PHIHONG	Model Name	UES-1001A160-R



1.2 Product Specification of Equipment Under Test

Standards-related Product Specification										
Tx/Rx Channel Frequency Range	2412 MHz ~ 2462 MHz									
Maximum Output Power to antenna	<p><Ant 1> 802.11b : 16.95 dBm (0.0495 W) 802.11g : 19.56 dBm (0.0904 W) 802.11n HT20 : 19.63 dBm (0.0918 W) 802.11n HT40 : 18.56 dBm (0.0718 W)</p> <p><Ant 2> 802.11b : 15.99 dBm (0.0397 W) 802.11g : 18.69 dBm (0.0740 W) 802.11n HT20 : 18.63 dBm (0.0729 W) 802.11n HT40 : 17.52 dBm (0.0565 W)</p> <p>MIMO <Ant. 1 + 2> 802.11b : 19.33 dBm (0.0857 W) 802.11g : 22.08 dBm (0.1614 W) 802.11n HT20 : 22.19 dBm (0.1656 W) 802.11n HT40 : 21.13 dBm (0.1297 W)</p>									
99% Occupied Bandwidth	<p><Ant 1> 802.11b : 13.65MHz 802.11g : 16.60MHz 802.11n HT20 : 17.75MHz 802.11n HT40 : 36.20MHz</p> <p><Ant 2> 802.11b : 13.60MHz 802.11g : 16.60MHz 802.11n HT20 : 17.80MHz 802.11n HT40 : 36.20MHz</p> <p>MIMO <Ant 1> 802.11b : 13.65MHz 802.11g : 16.60MHz 802.11n HT20 : 17.80MHz 802.11n HT40 : 36.30MHz</p> <p>MIMO <Ant 2> 802.11b : 13.60MHz 802.11g : 16.65MHz 802.11n HT20 : 17.75MHz 802.11n HT40 : 36.40MHz</p>									
Antenna Type / Gain	<p><Ant. 1> Ceramic Antenna with gain 2.0 dBi <Ant. 2> Ceramic Antenna with gain 1.0 dBi</p>									
Type of Modulation	802.11b : DSSS (DBPSK / DQPSK / CCK) 802.11g/n : OFDM (BPSK / QPSK / 16QAM / 64QAM)									
Antenna Function for Transmitter	<table border="1"> <thead> <tr> <th></th> <th>Ant. 1</th> <th>Ant. 2</th> </tr> </thead> <tbody> <tr> <td>802.11 b/g/n</td> <td>V</td> <td>V</td> </tr> <tr> <td>802.11 b/g/n MIMO</td> <td>V</td> <td>V</td> </tr> </tbody> </table>		Ant. 1	Ant. 2	802.11 b/g/n	V	V	802.11 b/g/n MIMO	V	V
	Ant. 1	Ant. 2								
802.11 b/g/n	V	V								
802.11 b/g/n MIMO	V	V								

Note: MIMO Ant. 1+2 is a calculated result from sum of the power MIMO Ant. 1 and MIMO Ant. 2.



1.3 Modification of EUT

No modifications are made to the EUT during all test items.

1.4 Testing Location

Test Site	SPORTON INTERNATIONAL INC.	
Test Site Location	No.52, Huaya 1st Rd., Guishan Dist., Taoyuan City, Taiwan (R.O.C.) TEL: +886-3-327-3456 FAX: +886-3-328-4978	
Test Site No.	Sporton Site No.	
	TH05-HY	CO05-HY

Note: The test site complies with ANSI C63.4 2014 requirement.

Test Site	SPORTON INTERNATIONAL INC.	
Test Site Location	No.58, Aly. 75, Ln. 564, Wenhua 3rd, Rd., Guishan Dist., Taoyuan City, Taiwan (R.O.C.) TEL: +886-3-327-0868 FAX: +886-3-327-0855	
Test Site No.	Sporton Site No.	
	03CH16-HY	

Note: The test site complies with ANSI C63.4 2014 requirement.

FCC Designation No. TW1190 and TW0007

1.5 Applicable Standards

According to the specifications of the manufacturer, the EUT must comply with the requirements of the following standards:

- ♦ FCC Part 15 Subpart C §15.247
- ♦ FCC KDB Publication No. 558074 D01 DTS Meas. Guidance v05
- ♦ FCC KDB 414788 D01 Radiated Test Site v01r01.
- ♦ FCC KDB 662911 D01 Multiple Transmitter Output v02r01.
- ♦ ANSI C63.10-2013

Remark:

1. All test items were verified and recorded according to the standards and without any deviation during the test.
2. This EUT has also been tested and complied with the requirements of FCC Part 15, Subpart B, recorded in a separate test report.



2 Test Configuration of Equipment Under Test

- a. The EUT has been associated with peripherals and configuration operated in a manner tended to maximize its emission characteristics in a typical application. Frequency range investigated: conduction emission (150 kHz to 30 MHz), radiation emission (9 kHz to the 10th harmonic of the highest fundamental frequency or to 40 GHz, whichever is lower). For radiated measurement, pre-scanned in three orthogonal panels, X, Y, Z. The worst cases (Y plane for Ant. 1, Z plane for Ant. 2 and MIMO Ant. 1+2) were recorded in this report.

- b. AC power line Conducted Emission was tested under maximum output power.

2.1 Carrier Frequency and Channel

Frequency Band	Channel	Freq. (MHz)	Channel	Freq. (MHz)
2400-2483.5 MHz	1	2412	7	2442
	2	2417	8	2447
	3	2422	9	2452
	4	2427	10	2457
	5	2432	11	2462
	6	2437		



2.2 Test Mode

Final test modes are considering the modulation and worse data rates as below table.

Single Antenna

Modulation	Data Rate
802.11b	1 Mbps
802.11g	6 Mbps
802.11n HT20	MCS0
802.11n HT40	MCS0

MIMO Mode

Modulation	Data Rate
802.11b	1 Mbps
802.11g	6 Mbps
802.11n HT20	MCS0
802.11n HT40	MCS0

Test Cases	
AC Conducted Emission	Mode 1: WLAN (2.4GHz) Link + Bluetooth Link + USB Cable (Type C) + Adapter + GPS Rx + NFC On



<Ant. 1>

802.11b mode						
Power vs. Channel			Average Power vs. Data Rate			
Channel	Frequency (MHz)	Data Rate (bps)	Channel	Data Rate (bps)		
		1M		2M	5.5M	11M
Duty Cycle (%)		98.80		98.27	97.96	97.00
CH 01	2412	13.82	CH 11	14.27	14.23	14.26
CH 06	2437	13.95				
CH 11	2462	14.28				

802.11b mode						
Power vs. Channel			Peak Power vs. Data Rate			
Channel	Frequency (MHz)	Data Rate (bps)	Channel	Data Rate (bps)		
		1M		2M	5.5M	11M
CH 01	2412	16.50	CH 11	16.93	16.92	16.94
CH 06	2437	16.65				
CH 11	2462	16.95				

802.11g mode										
Power vs. Channel			Average Power vs. Data Rate							
Channel	Frequency (MHz)	Data Rate (bps)	Channel	Data Rate (bps)						
		6M		9M	12M	18M	24M	36M	48M	54M
Duty Cycle (%)		98.56		96.48	96.28	94.52	92.11	92.31	90.32	89.09
CH 01	2412	14.04	CH 11	14.19	14.19	14.18	14.15	14.21	14.16	14.21
CH 06	2437	14.20								
CH 11	2462	14.22								

802.11g mode										
Power vs. Channel			Peak Power vs. Data Rate							
Channel	Frequency (MHz)	Data Rate (bps)	Channel	Data Rate (bps)						
		6M		9M	12M	18M	24M	36M	48M	54M
CH 01	2412	19.36	CH 11	19.51	19.55	19.42	19.44	19.53	19.52	19.41
CH 06	2437	19.45								
CH 11	2462	19.56								



802.11n HT20 mode										
Power vs. Channel			Average Power vs. Data Rate							
Channel	Frequency (MHz)	MCS Index	Channel	MCS Index						
		MCS0		MCS1	MCS2	MCS3	MCS4	MCS5	MCS6	MCS7
Duty Cycle (%)		98.20		96.02	95.68	94.39	92.00	89.83	88.68	82.35
CH 01	2412	14.00	CH 11	14.12	14.11	14.15	14.10	14.07	14.07	14.14
CH 06	2437	14.14								
CH 11	2462	14.16								

802.11n HT20 mode										
Power vs. Channel			Peak Power vs. Data Rate							
Channel	Frequency (MHz)	MCS Index	Channel	MCS Index						
		MCS0		MCS1	MCS2	MCS3	MCS4	MCS5	MCS6	MCS7
CH 01	2412	19.46	CH 11	19.53	19.59	19.53	19.58	19.36	19.55	19.53
CH 06	2437	19.51								
CH 11	2462	19.63								

802.11n HT40 mode										
Power vs. Channel			Average Power vs. Data Rate							
Channel	Frequency (MHz)	MCS Index	Channel	MCS Index						
		MCS0		MCS1	MCS2	MCS3	MCS4	MCS5	MCS6	MCS7
Duty Cycle (%)		95.88		93.20	89.04	91.23	83.72	77.14	81.25	80.65
CH 03	2422	14.26	CH 03	14.20	14.20	14.24	14.18	14.20	14.23	14.23
CH 06	2437	14.25								
CH 09	2452	14.11								

802.11n HT40 mode										
Power vs. Channel			Peak Power vs. Data Rate							
Channel	Frequency (MHz)	MCS Index	Channel	MCS Index						
		MCS0		MCS1	MCS2	MCS3	MCS4	MCS5	MCS6	MCS7
CH 03	2422	18.56	CH 03	18.53	18.48	18.46	18.54	18.52	18.38	18.43
CH 06	2437	18.45								
CH 09	2452	18.34								



<Ant. 2>

802.11b mode						
Power vs. Channel			Average Power vs. Data Rate			
Channel	Frequency (MHz)	Data Rate (bps)	Channel	Data Rate (bps)		
		1M		2M	5.5M	11M
Duty Cycle (%)		98.64		98.66	97.96	96.63
CH 01	2412	12.91	CH 06	13.17	13.14	13.17
CH 06	2437	13.20				
CH 11	2462	12.98				

802.11b mode						
Power vs. Channel			Peak Power vs. Data Rate			
Channel	Frequency (MHz)	Data Rate (bps)	Channel	Data Rate (bps)		
		1M		2M	5.5M	11M
CH 01	2412	15.65	CH 06	15.98	15.87	15.89
CH 06	2437	15.99				
CH 11	2462	15.80				

802.11g mode										
Power vs. Channel			Average Power vs. Data Rate							
Channel	Frequency (MHz)	Data Rate (bps)	Channel	Data Rate (bps)						
		6M		9M	12M	18M	24M	36M	48M	54M
Duty Cycle (%)		98.09		97.18	97.20	94.56	92.92	89.87	90.16	88.89
CH 01	2412	13.10	CH 11	13.16	13.15	13.18	13.15	13.17	13.17	13.10
CH 06	2437	13.14								
CH 11	2462	13.19								

802.11g mode										
Power vs. Channel			Peak Power vs. Data Rate							
Channel	Frequency (MHz)	Data Rate (bps)	Channel	Data Rate (bps)						
		6M		9M	12M	18M	24M	36M	48M	54M
CH 01	2412	18.41	CH 11	18.66	18.65	18.58	18.52	18.46	18.59	18.51
CH 06	2437	18.51								
CH 11	2462	18.69								



802.11n HT20 mode										
Power vs. Channel			Average Power vs. Data Rate							
Channel	Frequency (MHz)	MCS Index	Channel	MCS Index						
		MCS0		MCS1	MCS2	MCS3	MCS4	MCS5	MCS6	MCS7
Duty Cycle (%)		98.45		96.04	94.29	94.34	89.61	86.89	88.68	87.76
CH 01	2412	13.01	CH 11	13.01	13.02	13.04	13.00	12.97	12.97	13.01
CH 06	2437	13.04								
CH 11	2462	13.05								

802.11n HT20 mode										
Power vs. Channel			Peak Power vs. Data Rate							
Channel	Frequency (MHz)	MCS Index	Channel	MCS Index						
		MCS0		MCS1	MCS2	MCS3	MCS4	MCS5	MCS6	MCS7
CH 01	2412	18.53	CH 11	18.54	18.52	18.53	18.54	18.59	18.56	18.56
CH 06	2437	18.54								
CH 11	2462	18.63								

802.11n HT40 mode										
Power vs. Channel			Average Power vs. Data Rate							
Channel	Frequency (MHz)	MCS Index	Channel	MCS Index						
		MCS0		MCS1	MCS2	MCS3	MCS4	MCS5	MCS6	MCS7
Duty Cycle (%)		95.85		94.17	91.67	89.66	85.71	83.33	81.82	78.12
CH 03	2422	13.08	CH 09	13.02	13.13	13.02	13.14	13.12	13.08	13.15
CH 06	2437	13.11								
CH 09	2452	13.17								

802.11n HT40 mode										
Power vs. Channel			Peak Power vs. Data Rate							
Channel	Frequency (MHz)	MCS Index	Channel	MCS Index						
		MCS0		MCS1	MCS2	MCS3	MCS4	MCS5	MCS6	MCS7
CH 03	2422	17.41	CH 09	17.42	17.44	17.43	17.42	17.46	17.50	17.34
CH 06	2437	17.35								
CH 09	2452	17.52								



MIMO<Ant. 1 + 2>

802.11b mode						
Power vs. Channel			Average Power vs. Data Rate			
Channel	Frequency (MHz)	Data Rate (bps)	Channel	Data Rate (bps)		
		1M		2M	5.5M	11M
CH 01	2412	16.37	CH 11	16.62	16.62	16.63
CH 06	2437	16.59				
CH 11	2462	16.64				

802.11b mode						
Power vs. Channel			Peak Power vs. Data Rate			
Channel	Frequency (MHz)	Data Rate (bps)	Channel	Data Rate (bps)		
		1M		2M	5.5M	11M
CH 01	2412	19.09	CH 11	19.29	19.27	19.28
CH 06	2437	19.28				
CH 11	2462	19.33				

802.11g mode										
Power vs. Channel			Average Power vs. Data Rate							
Channel	Frequency (MHz)	Data Rate (bps)	Channel	Data Rate (bps)						
		6M		9M	12M	18M	24M	36M	48M	54M
CH 01	2412	16.62	CH 06	16.71	16.47	16.44	16.56	16.51	16.59	16.69
CH 06	2437	16.72								
CH 11	2462	16.71								

802.11g mode										
Power vs. Channel			Peak Power vs. Data Rate							
Channel	Frequency (MHz)	Data Rate (bps)	Channel	Data Rate (bps)						
		6M		9M	12M	18M	24M	36M	48M	54M
CH 01	2412	22.05	CH 06	22.05	21.79	21.79	21.97	21.84	22.00	22.07
CH 06	2437	22.08								
CH 11	2462	22.08								



802.11n HT20 mode										
Power vs. Channel			Average Power vs. Data Rate							
Channel	Frequency (MHz)	MCS Index	Channel	MCS Index						
		MCS0		MCS1	MCS2	MCS3	MCS4	MCS5	MCS6	MCS7
CH 01	2412	16.54	CH 11	16.19	16.24	16.29	16.38	16.33	16.54	16.41
CH 06	2437	16.65								
CH 11	2462	16.65								

802.11n HT20 mode										
Power vs. Channel			Peak Power vs. Data Rate							
Channel	Frequency (MHz)	MCS Index	Channel	MCS Index						
		MCS0		MCS1	MCS2	MCS3	MCS4	MCS5	MCS6	MCS7
CH 01	2412	22.10	CH 11	21.78	21.72	22.15	22.04	21.92	22.12	21.93
CH 06	2437	22.16								
CH 11	2462	22.19								

802.11n HT40 mode										
Power vs. Channel			Average Power vs. Data Rate							
Channel	Frequency (MHz)	MCS Index	Channel	MCS Index						
		MCS0		MCS1	MCS2	MCS3	MCS4	MCS5	MCS6	MCS7
CH 03	2422	16.60	CH 06	13.02	13.13	13.02	13.14	13.12	13.08	13.15
CH 06	2437	16.62								
CH 09	2452	16.60								

802.11n HT40 mode										
Power vs. Channel			Peak Power vs. Data Rate							
Channel	Frequency (MHz)	MCS Index	Channel	MCS Index						
		MCS0		MCS1	MCS2	MCS3	MCS4	MCS5	MCS6	MCS7
CH 03	2422	20.98	CH 06	20.85	20.85	20.85	20.85	20.85	20.85	20.85
CH 06	2437	21.13								
CH 09	2452	21.11								

2.3 Connection Diagram of Test System

<WLAN Tx Mode>

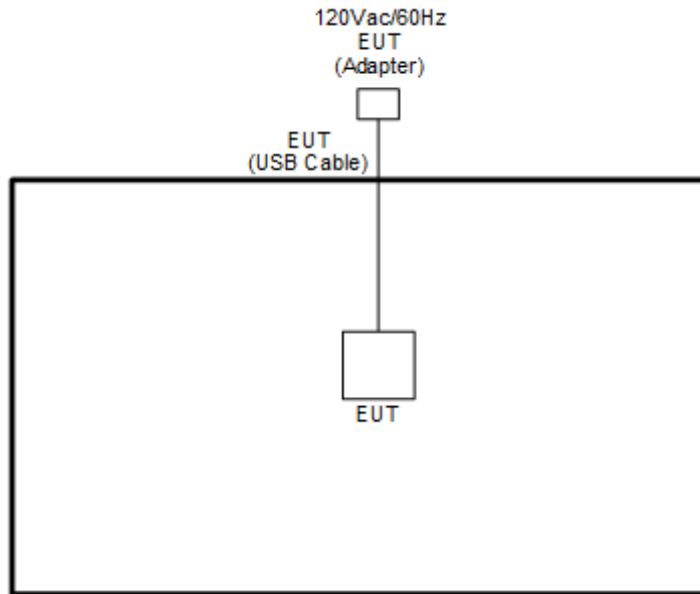

<AC Conducted Emission Mode>

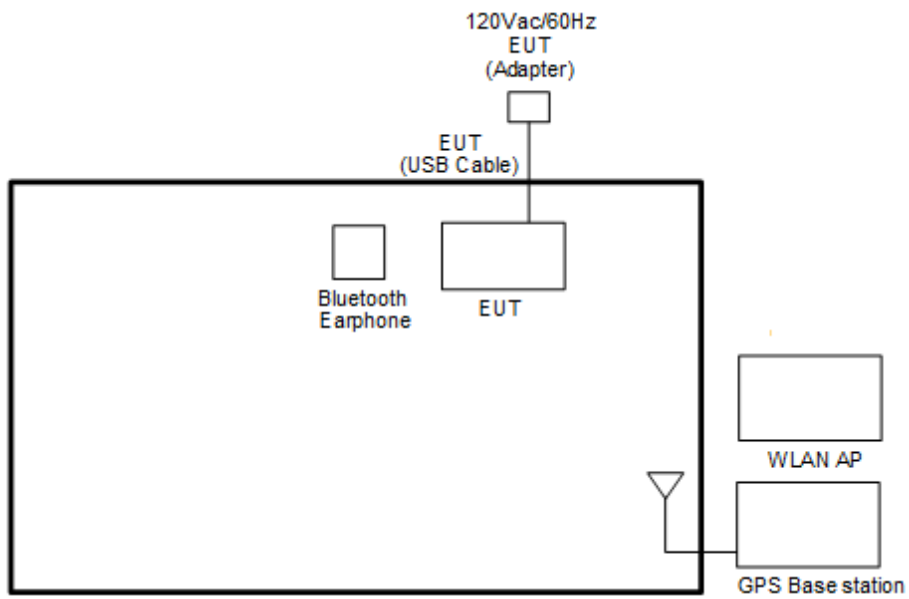



2.4 Support Unit used in test configuration and system

Item	Equipment	Trade Name	Model Name	FCC ID	Data Cable	Power Cord
1.	GPS Station	Pendulum	GSG-54	N/A	N/A	Unshielded, 1.8 m
2.	Bluetooth Earphone	Sony Ericsson	MW600	PY7DDA-2029	N/A	N/A
3.	WLAN AP	ASUS	RT-AC66U	MSQ-RTAC66U	N/A	Unshielded, 1.8 m
4.	SD Card	SanDisk	MicroSD HC	FCC DoC	N/A	N/A

2.5 EUT Operation Test Setup

The RF test items, utility “DRTU” was installed in EUT which was programmed in order to make the EUT get into the engineering modes to provide channel selection, power level, data rate and the application type and for continuous transmitting signals.

2.6 Measurement Results Explanation Example

For all conducted test items:

The offset level is set in the spectrum analyzer to compensate the RF cable loss and attenuator factor between EUT conducted output port and spectrum analyzer. With the offset compensation, the spectrum analyzer reading level is exactly the EUT RF output level.

Example:

The spectrum analyzer offset is derived from RF cable loss and attenuator factor.

Offset = RF cable loss + attenuator factor.

Following shows an offset computation example with cable loss 4.2 dB and 10dB attenuator.

Offset(dB) = RF cable loss(dB) + attenuator factor(dB).

= 4.2 + 10 = 14.2 (dB)

3 Test Result

3.1 6dB and 99% Bandwidth Measurement

3.1.1 Limit of 6dB and 99% Bandwidth

The minimum 6 dB bandwidth shall be at least 500 kHz.

3.1.2 Measuring Instruments

See list of measuring equipment of this test report.

3.1.3 Test Procedures

1. The testing follows the ANSI C63.10 Section 6.9.3 (OBW) and 11.8.1 (6dB BW).
2. The RF output of EUT was connected to the spectrum analyzer by RF cable and attenuator. The path loss was compensated to the results for each measurement.
3. Set to the maximum power setting and enable the EUT transmit continuously.
4. Make the measurement with the spectrum analyzer's resolution bandwidth (RBW) = 100 kHz. Set the Video bandwidth (VBW) = 300 kHz. In order to make an accurate measurement. The 6 dB bandwidth must be greater than 500 kHz.
5. For 99% Bandwidth Measurement, the spectrum analyzer's resolution bandwidth (RBW) is set 1-5% of the emission bandwidth and set the Video bandwidth (VBW) $\geq 3 * RBW$.
6. Measure and record the results in the test report.

3.1.4 Test Setup

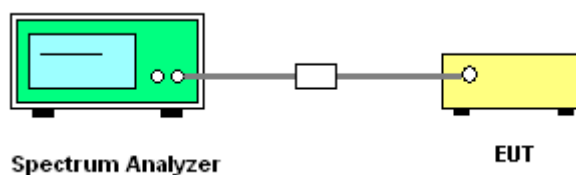



3.1.5 Test Result of 6dB and 99% Occupied Bandwidth

Test Engineer :	Allen Lin and AnAn Wu	Temperature :	21~25°C
		Relative Humidity :	51~54%

2.4GHz Band										
Mod.	Data Rate	NTX	CH.	Freq. (MHz)	99% Occupied BW (MHz)		6dB BW (MHz)		6dB BW Limit (MHz)	Pass/Fail
					Ant 1	Ant 2	Ant 1	Ant 2		
11b	1Mbps	1	1	2412	13.65	13.60	10.08	10.10	0.50	Pass
11b	1Mbps	1	6	2437	13.60	13.60	10.10	10.07	0.50	Pass
11b	1Mbps	1	11	2462	13.55	13.45	10.10	10.08	0.50	Pass
11g	6Mbps	1	1	2412	16.55	16.60	15.08	15.10	0.50	Pass
11g	6Mbps	1	6	2437	16.60	16.60	15.12	15.60	0.50	Pass
11g	6Mbps	1	11	2462	16.60	16.50	15.30	15.30	0.50	Pass
HT20	MCS0	1	1	2412	17.70	17.80	15.30	15.12	0.50	Pass
HT20	MCS0	1	6	2437	17.75	17.75	15.12	15.42	0.50	Pass
HT20	MCS0	1	11	2462	17.70	17.70	15.92	15.92	0.50	Pass
HT40	MCS0	1	3	2422	36.20	36.10	35.08	35.08	0.50	Pass
HT40	MCS0	1	6	2437	36.20	36.20	35.04	35.20	0.50	Pass
HT40	MCS0	1	9	2452	36.10	36.20	33.84	34.08	0.50	Pass
11b	1Mbps	2	1	2412	13.55	13.60	10.02	10.05	0.50	Pass
11b	1Mbps	2	6	2437	13.65	13.55	10.10	10.08	0.50	Pass
11b	1Mbps	2	11	2462	13.55	13.50	10.10	10.10	0.50	Pass
11g	6Mbps	2	1	2412	16.55	16.65	15.12	15.62	0.50	Pass
11g	6Mbps	2	6	2437	16.55	16.55	15.12	15.12	0.50	Pass
11g	6Mbps	2	11	2462	16.60	16.55	15.30	15.04	0.50	Pass
HT20	MCS0	2	1	2412	17.70	17.75	15.10	15.08	0.50	Pass
HT20	MCS0	2	6	2437	17.75	17.75	15.12	15.10	0.50	Pass
HT20	MCS0	2	11	2462	17.80	17.70	15.92	15.04	0.50	Pass
HT40	MCS0	2	3	2422	36.30	36.30	35.08	33.82	0.50	Pass
HT40	MCS0	2	6	2437	36.20	36.40	35.12	35.12	0.50	Pass
HT40	MCS0	2	9	2452	36.20	36.30	32.56	32.56	0.50	Pass

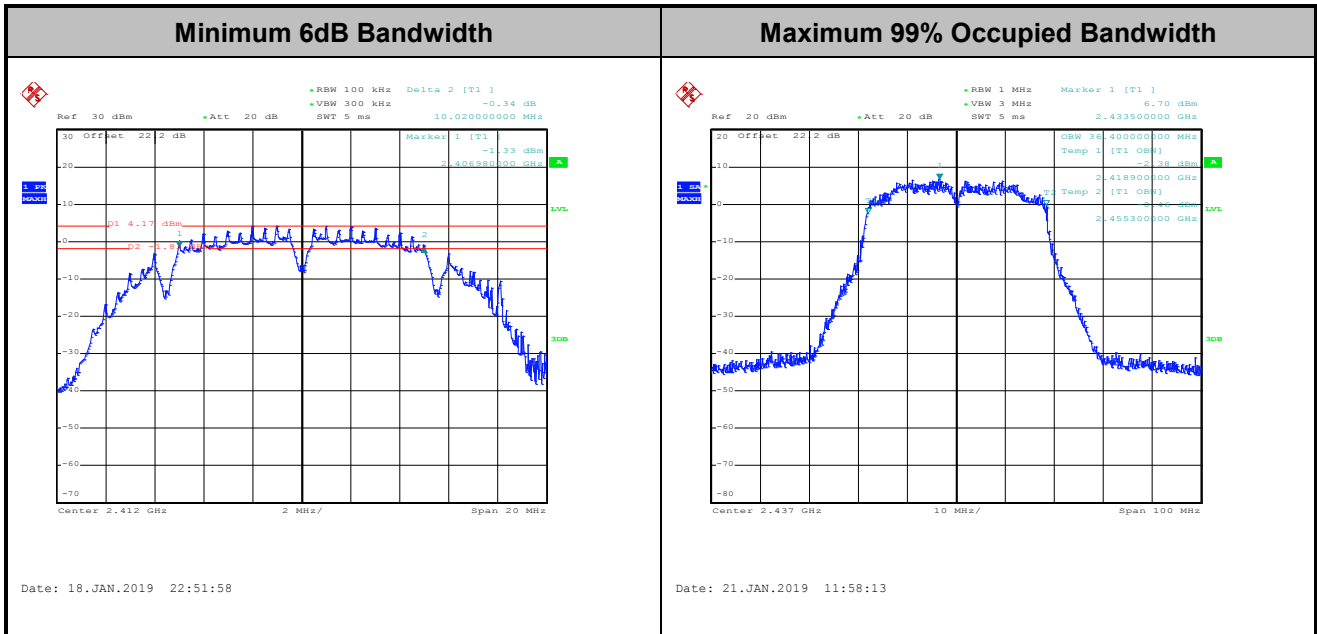

Note: The occupied channel bandwidth is maintained within the band of operation for all of the modulations.

3.2 Output Power Measurement

3.2.1 Limit of Output Power

For systems using digital modulation in the 2400-2483.5MHz, the limit for peak output power is 30dBm. If transmitting antenna with directional gain greater than 6dBi is used, the peak output power from the intentional radiator shall be reduced below the above stated value by the amount in dB that the directional gain of the antenna exceeds 6 dBi. In case of point-to-point operation, the limit has to be reduced by 1dB for every 3dB that the directional gain of the antenna exceeds 6dBi.

3.2.2 Measuring Instruments

See list of measuring equipment of this test report.

3.2.3 Test Procedures

1. For Peak Power, the testing follows ANSI C63.10 Section 11.9.1.3 PKPM1
2. For Average Power, the testing follows the Measurement Procedure of FCC KDB No. 558074 DTS D01 Meas. Guidance v05 section 9.2.3.1 Method AVGPM.
3. The RF output of EUT was connected to the power meter by RF cable and attenuator. The path loss was compensated to the results for each measurement.
4. Set to the maximum power setting and enable the EUT transmit continuously.
5. Measure the conducted output power and record the results in the test report.
6. For MIMO mode, calculation method follows FCC KDB 662911 D01 Multiple Transmitter Output v02r01.

3.2.4 Test Setup

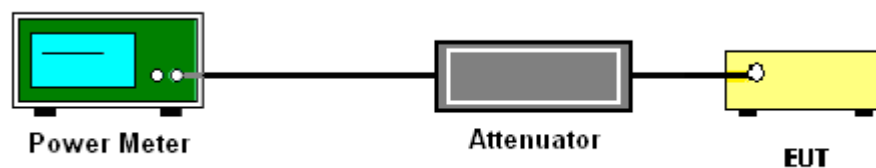



3.2.5 Test Result of Peak Output Power

Test Engineer :	Allen Lin and AnAn Wu	Temperature :	21~25°C
		Relative Humidity :	51~54%

2.4GHz Band																
Mod.	Data Rate	NTX	CH.	Freq. (MHz)	Peak Conducted Power (dBm)			Conducted Power Limit (dBm)		DG (dBi)		EIRP Power (dBm)		EIRP Power Limit (dBm)		Pass /Fail
					Ant 1	Ant 2	SUM	Ant 1	Ant 2	Ant 1	Ant 2	Ant 1	Ant 2	Ant 1	Ant 2	
11b	1Mbps	1	1	2412	16.50	15.65	-	30.00	30.00	2.00	1.00	18.50	16.65	36.00	36.00	Pass
11b	1Mbps	1	6	2437	16.65	15.99	-	30.00	30.00	2.00	1.00	18.65	16.99	36.00	36.00	Pass
11b	1Mbps	1	11	2462	16.95	15.80	-	30.00	30.00	2.00	1.00	18.95	16.80	36.00	36.00	Pass
11g	6Mbps	1	1	2412	19.36	18.41	-	30.00	30.00	2.00	1.00	21.36	19.41	36.00	36.00	Pass
11g	6Mbps	1	6	2437	19.45	18.51	-	30.00	30.00	2.00	1.00	21.45	19.51	36.00	36.00	Pass
11g	6Mbps	1	11	2462	19.56	18.69	-	30.00	30.00	2.00	1.00	21.56	19.69	36.00	36.00	Pass
HT20	MCS0	1	1	2412	19.46	18.53	-	30.00	30.00	2.00	1.00	21.46	19.53	36.00	36.00	Pass
HT20	MCS0	1	6	2437	19.51	18.54	-	30.00	30.00	2.00	1.00	21.51	19.54	36.00	36.00	Pass
HT20	MCS0	1	11	2462	19.63	18.63	-	30.00	30.00	2.00	1.00	21.63	19.63	36.00	36.00	Pass
HT40	MCS0	1	3	2422	18.56	17.41	-	30.00	30.00	2.00	1.00	20.56	18.41	36.00	36.00	Pass
HT40	MCS0	1	6	2437	18.45	17.35	-	30.00	30.00	2.00	1.00	20.45	18.35	36.00	36.00	Pass
HT40	MCS0	1	9	2452	18.34	17.52	-	30.00	30.00	2.00	1.00	20.34	18.52	36.00	36.00	Pass
11b	1Mbps	2	1	2412	16.47	15.64	19.09	30.00	30.00	2.00	1.00	21.09	19.09	36.00	36.00	Pass
11b	1Mbps	2	6	2437	16.59	15.92	19.28	30.00	30.00	2.00	1.00	21.28	19.28	36.00	36.00	Pass
11b	1Mbps	2	11	2462	16.80	15.79	19.33	30.00	30.00	2.00	1.00	21.33	19.33	36.00	36.00	Pass
11g	6Mbps	2	1	2412	19.50	18.52	22.05	30.00	30.00	2.00	1.00	24.05	22.05	36.00	36.00	Pass
11g	6Mbps	2	6	2437	19.52	18.57	22.08	30.00	30.00	2.00	1.00	24.08	22.08	36.00	36.00	Pass
11g	6Mbps	2	11	2462	19.53	18.55	22.08	30.00	30.00	2.00	1.00	24.08	22.08	36.00	36.00	Pass
HT20	MCS0	2	1	2412	19.55	18.57	22.10	30.00	30.00	2.00	1.00	24.10	22.10	36.00	36.00	Pass
HT20	MCS0	2	6	2437	19.64	18.60	22.16	30.00	30.00	2.00	1.00	24.16	22.16	36.00	36.00	Pass
HT20	MCS0	2	11	2462	19.60	18.71	22.19	30.00	30.00	2.00	1.00	24.19	22.19	36.00	36.00	Pass
HT40	MCS0	2	3	2422	18.45	17.44	20.98	30.00	30.00	2.00	1.00	22.98	20.98	36.00	36.00	Pass
HT40	MCS0	2	6	2437	18.46	17.75	21.13	30.00	30.00	2.00	1.00	23.13	21.13	36.00	36.00	Pass
HT40	MCS0	2	9	2452	18.60	17.53	21.11	30.00	30.00	2.00	1.00	23.11	21.11	36.00	36.00	Pass



3.2.6 Test Result of Average output Power (Reporting Only)

Test Engineer :	Allen Lin and AnAn Wu	Temperature :	21~25°C
		Relative Humidity :	51~54%

2.4GHz Band									
Mod.	Data Rate	NTX	CH.	Freq. (MHz)	Duty Factor (dB)		Average Conducted Power (dBm)		
					Ant 1	Ant 2	Ant 1	Ant 2	SUM
11b	1Mbps	1	1	2412	0.05	0.06	13.82	12.91	
11b	1Mbps	1	6	2437	0.05	0.06	13.95	13.20	
11b	1Mbps	1	11	2462	0.05	0.06	14.28	12.98	
11g	6Mbps	1	1	2412	0.06	0.08	14.04	13.10	
11g	6Mbps	1	6	2437	0.06	0.08	14.20	13.14	
11g	6Mbps	1	11	2462	0.06	0.08	14.22	13.19	
HT20	MCS0	1	1	2412	0.08	0.07	14.00	13.01	
HT20	MCS0	1	6	2437	0.08	0.07	14.14	13.04	
HT20	MCS0	1	11	2462	0.08	0.07	14.16	13.05	
HT40	MCS0	1	3	2422	0.18	0.18	14.26	13.08	
HT40	MCS0	1	6	2437	0.18	0.18	14.25	13.11	
HT40	MCS0	1	9	2452	0.18	0.18	14.11	13.17	
11b	1Mbps	2	1	2412	0.08	0.05	13.80	12.86	16.37
11b	1Mbps	2	6	2437	0.08	0.05	13.94	13.18	16.59
11b	1Mbps	2	11	2462	0.08	0.05	14.21	12.95	16.64
11g	6Mbps	2	1	2412	0.07	0.07	14.09	13.07	16.62
11g	6Mbps	2	6	2437	0.07	0.07	14.20	13.16	16.72
11g	6Mbps	2	11	2462	0.07	0.07	14.18	13.15	16.71
HT20	MCS0	2	1	2412	0.10	0.10	14.00	13.00	16.54
HT20	MCS0	2	6	2437	0.10	0.10	14.15	13.07	16.65
HT20	MCS0	2	11	2462	0.10	0.10	14.11	13.11	16.65
HT40	MCS0	2	3	2422	0.20	0.18	14.03	13.10	16.60
HT40	MCS0	2	6	2437	0.20	0.18	14.01	13.16	16.62
HT40	MCS0	2	9	2452	0.20	0.18	14.07	13.06	16.60

3.3 Power Spectral Density Measurement

3.3.1 Limit of Power Spectral Density

The peak power spectral density shall not be greater than 8dBm in any 3kHz band at any time interval of continuous transmission.

3.3.2 Measuring Instruments

See list of measuring equipment of this test report.

3.3.3 Test Procedures

1. The testing follows the ANSI C63.10 Section 11.10.2 Method PKPSD.
2. The RF output of EUT was connected to the spectrum analyzer by RF cable and attenuator. The path loss was compensated to the results for each measurement.
3. Set to the maximum power setting and enable the EUT transmit continuously.
4. Make the measurement with the spectrum analyzer's resolution bandwidth (RBW) = 3 kHz. Video bandwidth VBW = 10 kHz In order to make an accurate measurement, set the span to 1.5 times DTS Channel Bandwidth. (6dB BW)
5. Detector = peak, Sweep time = auto couple, Trace mode = max hold, Allow trace to fully stabilize. Use the peak marker function to determine the maximum power level.
6. Measure and record the results in the test report.
7. For MIMO mode, calculation method follows FCC KDB 662911 D01 Multiple Transmitter Output v02r01.

If measurements performed using method (2) plus $10 \log(N)$ exceeds the emission limit, the test should choose method (1) before declaring that the device fails the emission limit.

Method (1): Measure and sum the spectra across the outputs.

The total final Power Spectral Density is from a device with 2 transmitter outputs. The spectrum measurements of the individual outputs are all performed with the same span and number of points, the spectrum value in the first spectral bin of output 1 is summed with that in the first spectral bin of output 2 to obtain the value for the first frequency bin of the summed spectrum.

Method (2): Measure and add $10 \log(N)$ dB, where N is the number of outputs. (N=2)

3.3.4 Test Setup

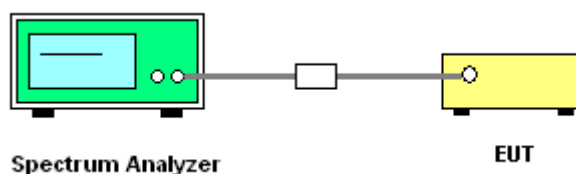



3.3.5 Test Result of Power Spectral Density

Test Engineer :	Allen Lin and AnAn Wu	Temperature :	21~25°C
		Relative Humidity :	51~54%

2.4GHz Band												
Mod.	Data Rate	NTX	CH.	Freq. (MHz)	Peak PSD (dBm/3kHz)			DG (dBi)		Peak PSD Limit (dBm/3kHz)		Pass/Fail
					Ant 1	Ant 2	Worse + 3.01	Ant 1	Ant 2	Ant 1	Ant 2	
11b	1Mbps	1	1	2412	-9.42	-10.25	-	2.00	1.00	8.00	8.00	Pass
11b	1Mbps	1	6	2437	-10.05	-10.27	-	2.00	1.00	8.00	8.00	Pass
11b	1Mbps	1	11	2462	-10.22	-10.10	-	2.00	1.00	8.00	8.00	Pass
11g	6Mbps	1	1	2412	-11.49	-12.21	-	2.00	1.00	8.00	8.00	Pass
11g	6Mbps	1	6	2437	-10.69	-12.76	-	2.00	1.00	8.00	8.00	Pass
11g	6Mbps	1	11	2462	-10.50	-11.83	-	2.00	1.00	8.00	8.00	Pass
HT20	MCS0	1	1	2412	-11.59	-10.46	-	2.00	1.00	8.00	8.00	Pass
HT20	MCS0	1	6	2437	-10.68	-12.46	-	2.00	1.00	8.00	8.00	Pass
HT20	MCS0	1	11	2462	-13.26	-11.65	-	2.00	1.00	8.00	8.00	Pass
HT40	MCS0	1	3	2422	-14.05	-15.47	-	2.00	1.00	8.00	8.00	Pass
HT40	MCS0	1	6	2437	-14.44	-16.30	-	2.00	1.00	8.00	8.00	Pass
HT40	MCS0	1	9	2452	-14.47	-16.33	-	2.00	1.00	8.00	8.00	Pass
11b	1Mbps	2	1	2412	-9.69	-10.63	-6.68	4.52		8.00		Pass
11b	1Mbps	2	6	2437	-9.17	-10.78	-6.16	4.52		8.00		Pass
11b	1Mbps	2	11	2462	-9.11	-10.93	-6.10	4.52		8.00		Pass
11g	6Mbps	2	1	2412	-10.93	-12.28	-7.92	4.52		8.00		Pass
11g	6Mbps	2	6	2437	-11.69	-12.64	-8.68	4.52		8.00		Pass
11g	6Mbps	2	11	2462	-11.57	-11.60	-8.56	4.52		8.00		Pass
HT20	MCS0	2	1	2412	-12.22	-12.05	-9.04	4.52		8.00		Pass
HT20	MCS0	2	6	2437	-11.12	-11.96	-8.11	4.52		8.00		Pass
HT20	MCS0	2	11	2462	-10.46	-12.47	-7.45	4.52		8.00		Pass
HT40	MCS0	2	3	2422	-14.63	-14.30	-11.29	4.52		8.00		Pass
HT40	MCS0	2	6	2437	-15.68	-15.99	-12.67	4.52		8.00		Pass
HT40	MCS0	2	9	2452	-14.04	-14.78	-11.03	4.52		8.00		Pass

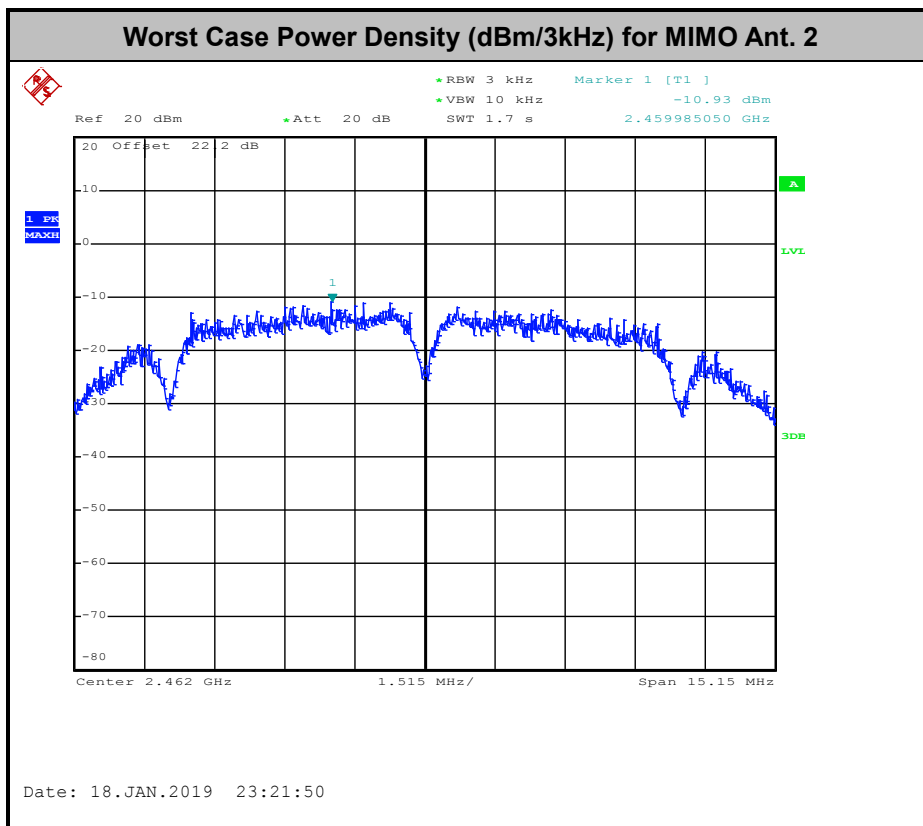
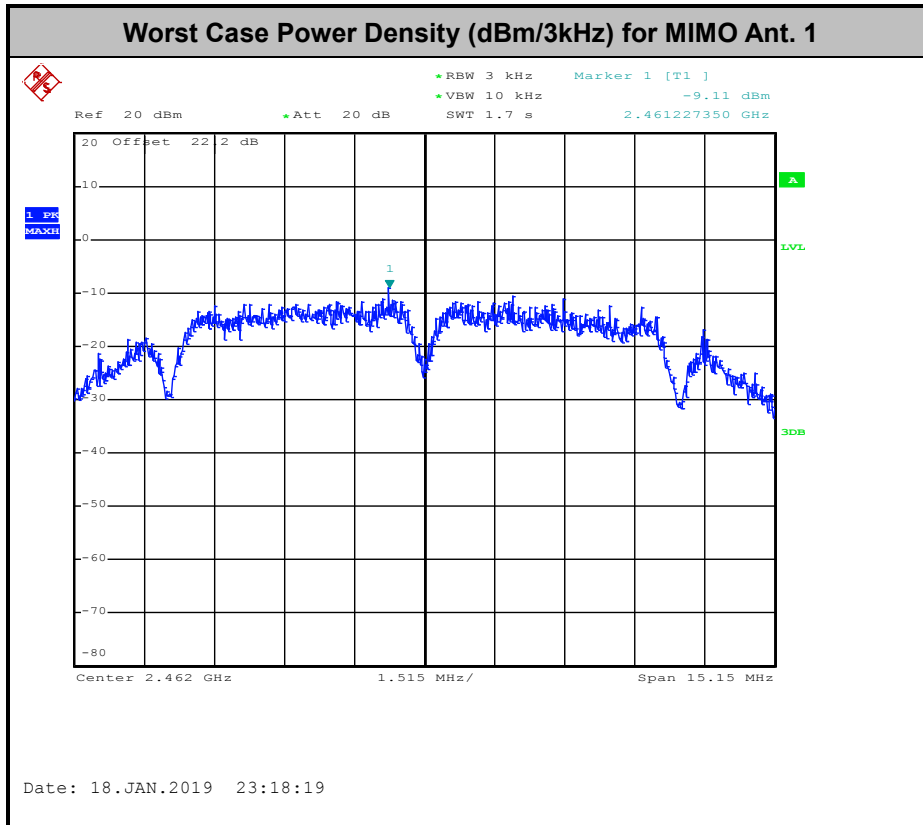

3.4 Conducted Band Edges and Spurious Emission Measurement

3.4.1 Limit of Conducted Band Edges and Spurious Emission Measurement

In any 100 kHz bandwidth outside of the authorized frequency band, the emissions which fall in the non-restricted bands shall be attenuated at least 20 dB / 30dB relative to the maximum PSD level in 100 kHz by RF conducted measurement.

3.4.2 Measuring Instruments

See list of measuring equipment of this test report.

3.4.3 Test Procedures

1. The testing follows the ANSI C63.10 Section 11.11.3 Emission level measurement.
2. The RF output of EUT was connected to the spectrum analyzer by RF cable and attenuator. The path loss was compensated to the results for each measurement.
3. Set to the maximum power setting and enable the EUT transmit continuously.
4. Set RBW = 100 kHz, VBW=300 kHz, Peak Detector. Unwanted Emissions measured in any 100 kHz bandwidth outside of the authorized frequency band shall be attenuated by at least 20 dB relative to the maximum in-band peak PSD level in 100 kHz when maximum peak conducted output power procedure is used. If the transmitter complies with the conducted power limits based on the use of RMS averaging over a time interval, the attenuation required under this paragraph shall be 30 dB instead of 20 dB per 15.247(d).
5. Measure and record the results in the test report.
6. The RF fundamental frequency should be excluded against the limit line in the operating frequency band.

3.4.4 Test Setup

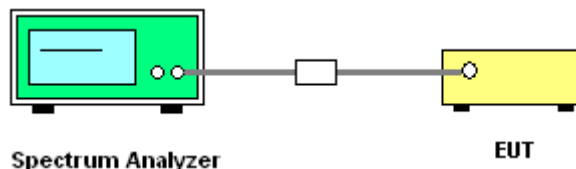



3.4.5 Test Result of Conducted Band Edges and Spurious Emission

Test Engineer : Allen Lin and AnAn Wu	Temperature :	21~25°C
	Relative Humidity :	51~54%

Number of TX = 1, Ant. 1 (Measured)

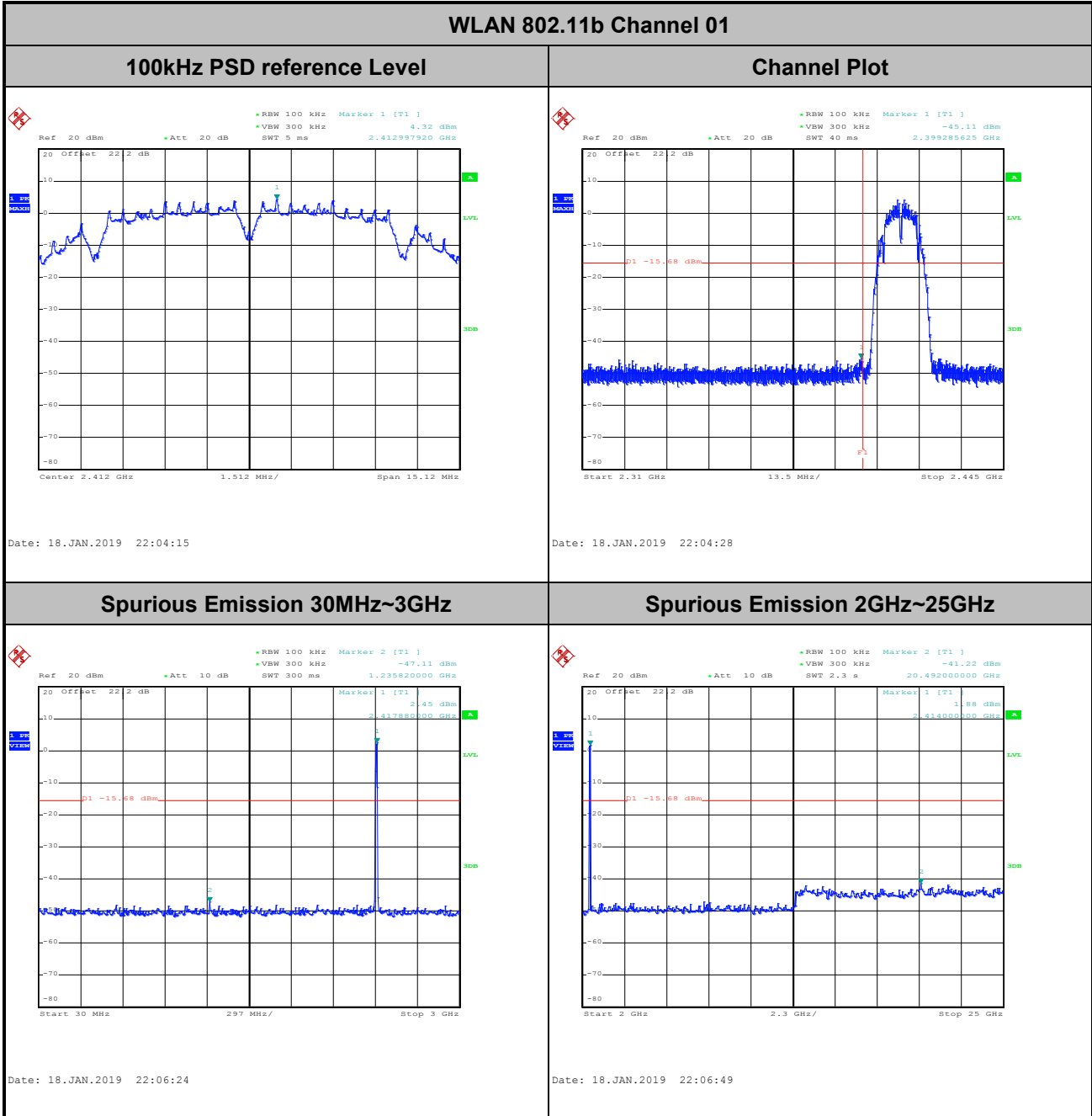



WLAN 802.11b Channel 06

100kHz PSD reference Level

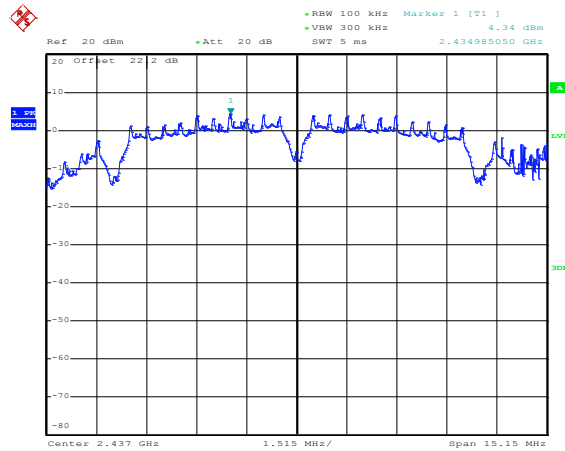

Date: 18.JAN.2019 22:12:06

Spurious Emission 30MHz~3GHz

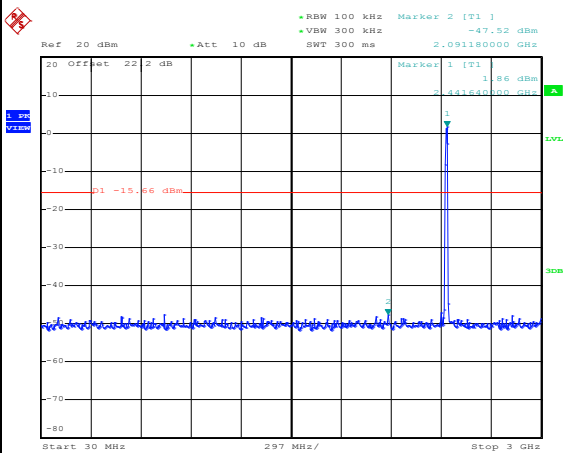

Date: 18.JAN.2019 22:12:21

Spurious Emission 2GHz~25GHz

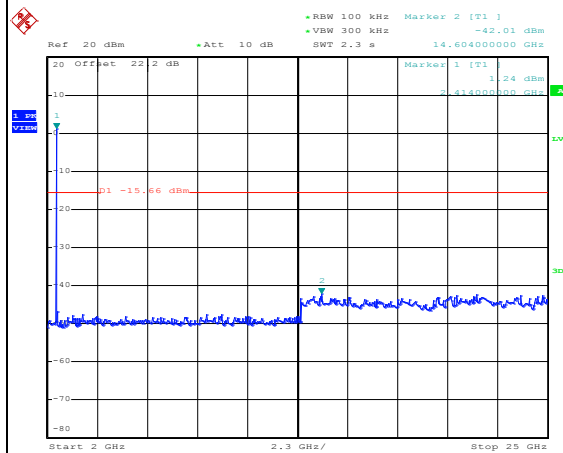

Date: 18.JAN.2019 22:12:50



WLAN 802.11b Channel 11

100kHz PSD reference Level

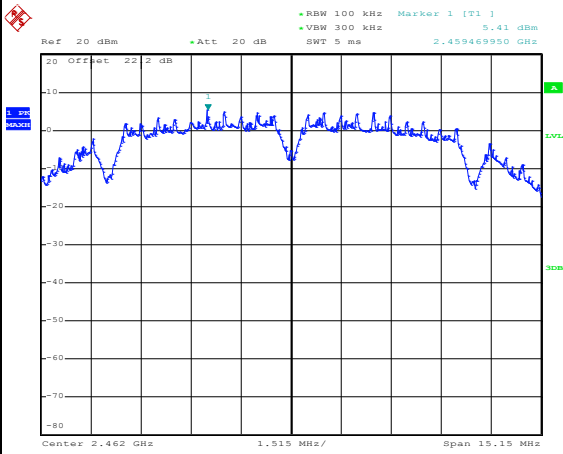

Date: 18.JAN.2019 22:15:51

Channel Plot

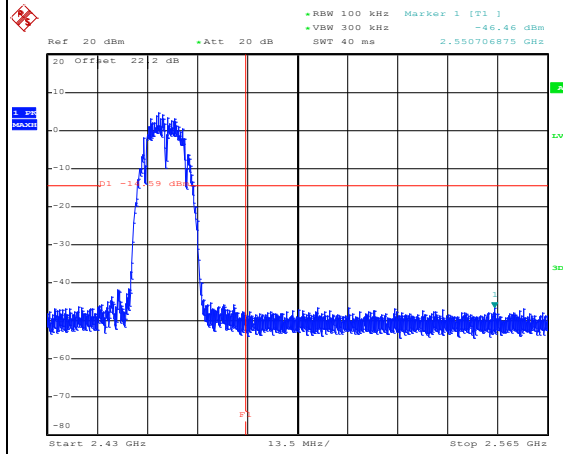

Date: 18.JAN.2019 22:16:16

Spurious Emission 30MHz~3GHz

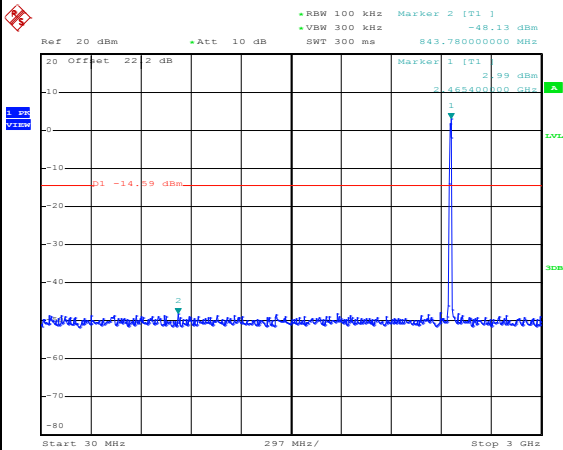

Date: 18.JAN.2019 22:17:06

Spurious Emission 2GHz~25GHz

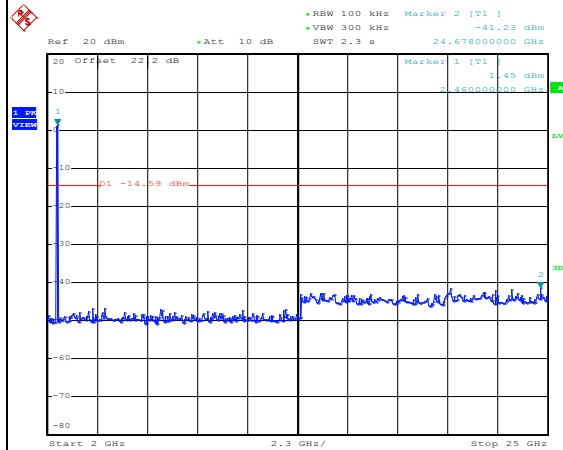

Date: 18.JAN.2019 22:17:21



WLAN 802.11g Channel 06

100kHz PSD reference Level

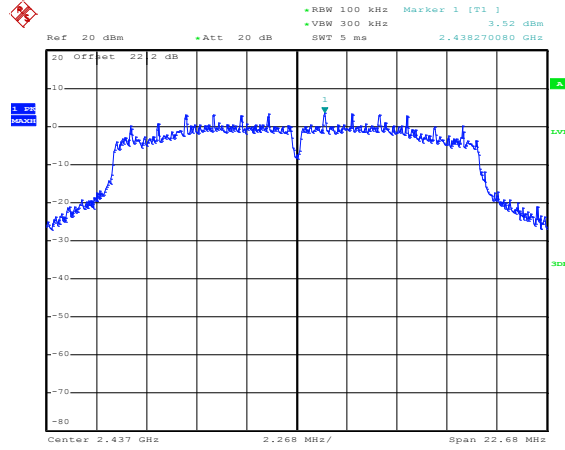

Date: 18.JAN.2019 23:42:12

Spurious Emission 30MHz~3GHz

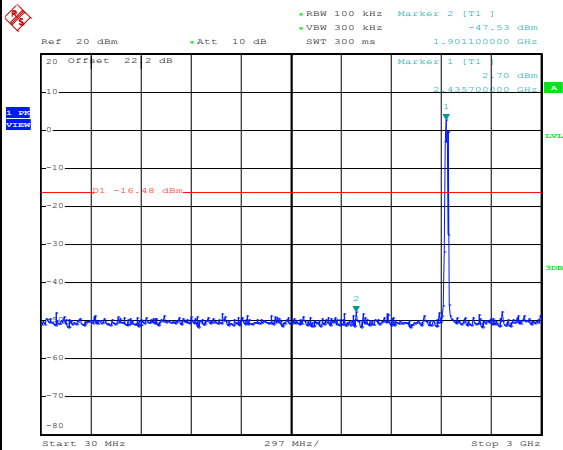

Date: 18.JAN.2019 23:42:27

Spurious Emission 2GHz~25GHz

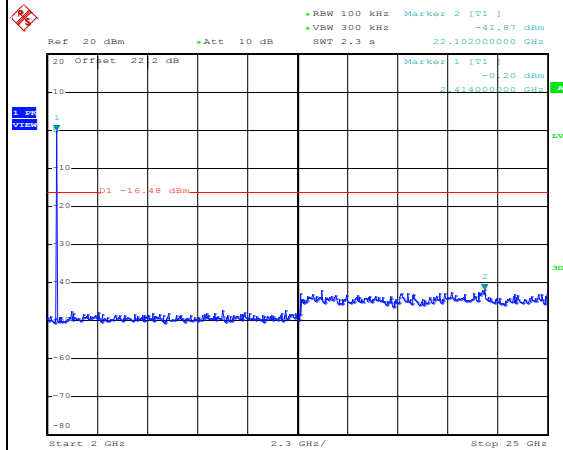

Date: 18.JAN.2019 23:43:12



WLAN 802.11g Channel 11

100kHz PSD reference Level

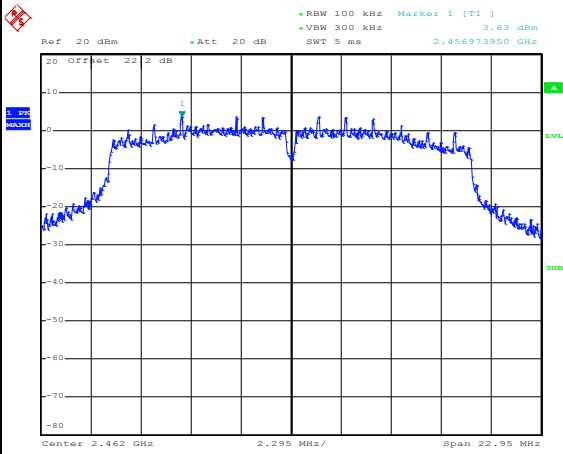

Date: 18.JAN.2019 23:46:30

Channel Plot

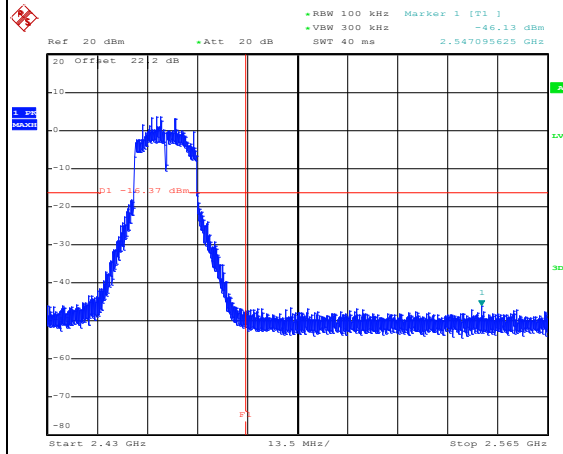

Date: 18.JAN.2019 23:46:43

Spurious Emission 30MHz~3GHz

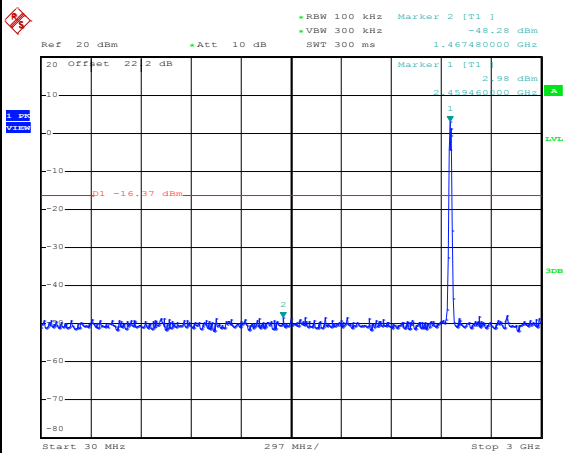

Date: 18.JAN.2019 23:47:00

Spurious Emission 2GHz~25GHz

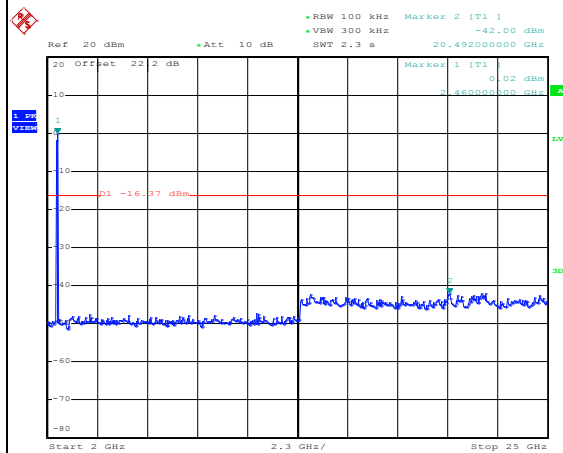

Date: 18.JAN.2019 23:47:15

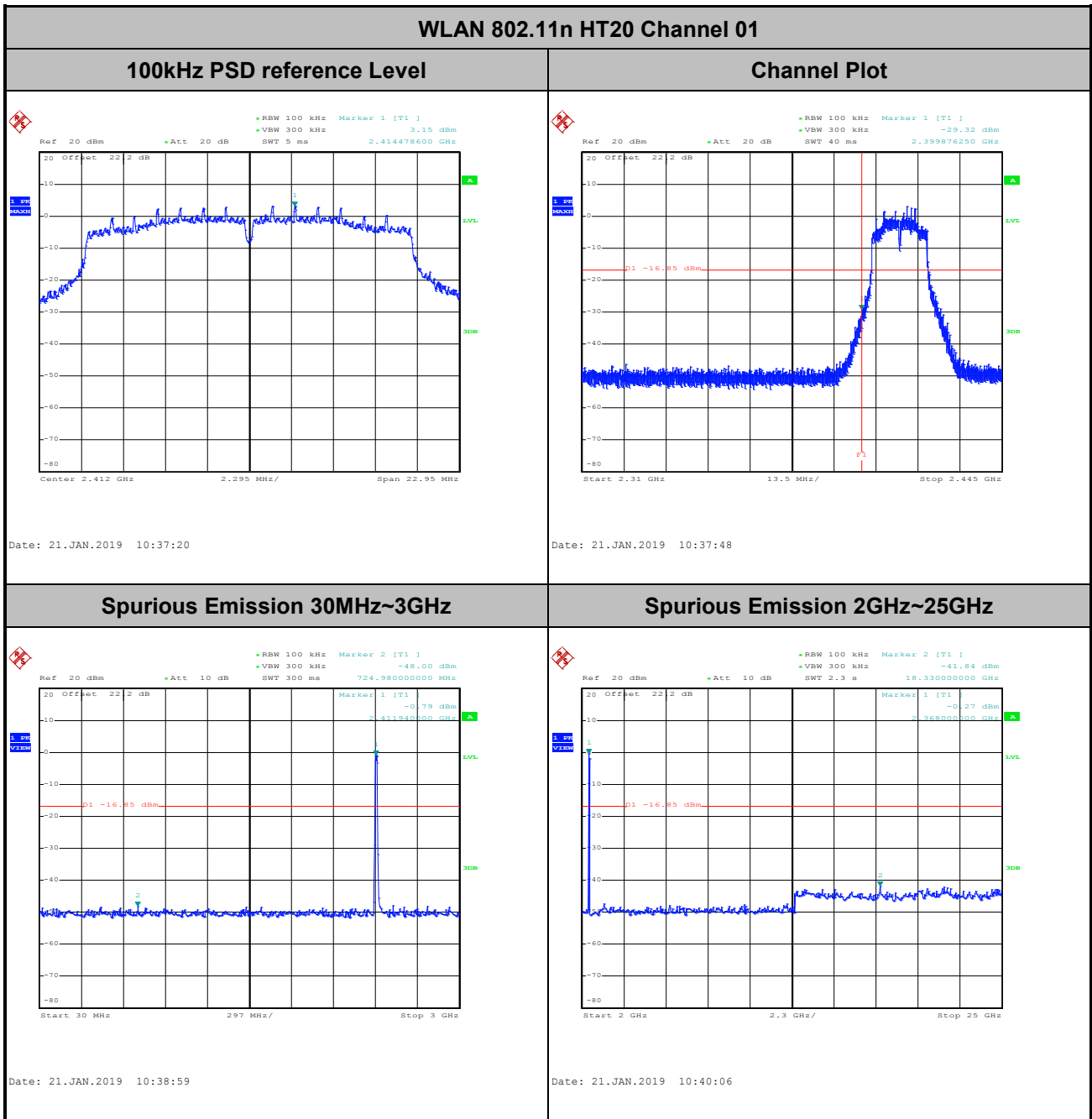



WLAN 802.11n HT20 Channel 06

100kHz PSD reference Level

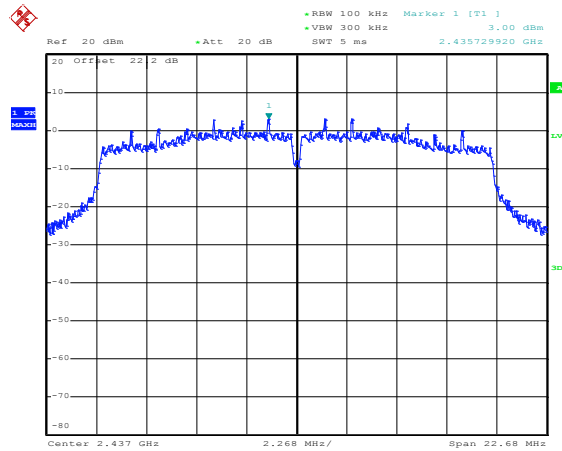

Date: 21.JAN.2019 10:45:00

Spurious Emission 30MHz~3GHz

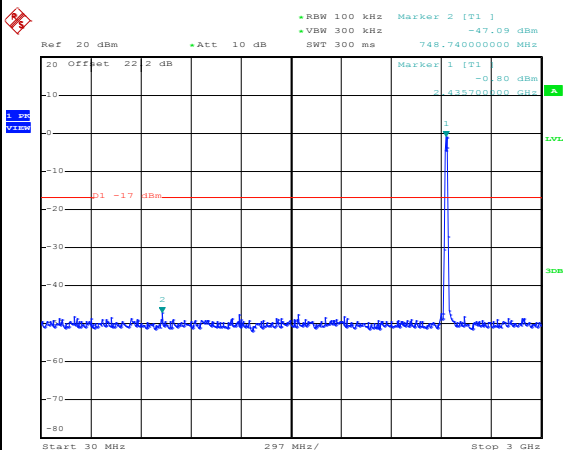

Date: 21.JAN.2019 10:45:19

Spurious Emission 2GHz~25GHz

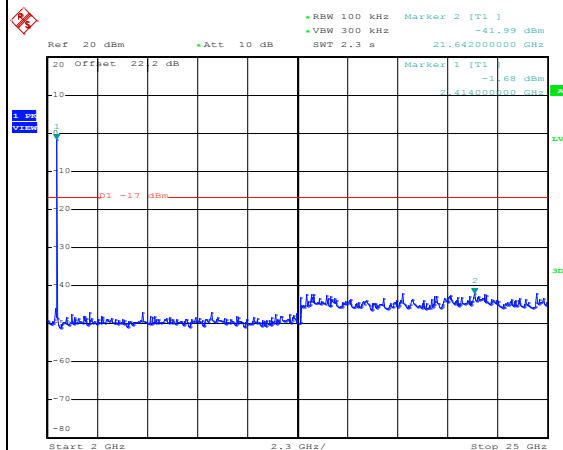

Date: 21.JAN.2019 10:45:36



WLAN 802.11n HT20 Channel 11

100kHz PSD reference Level

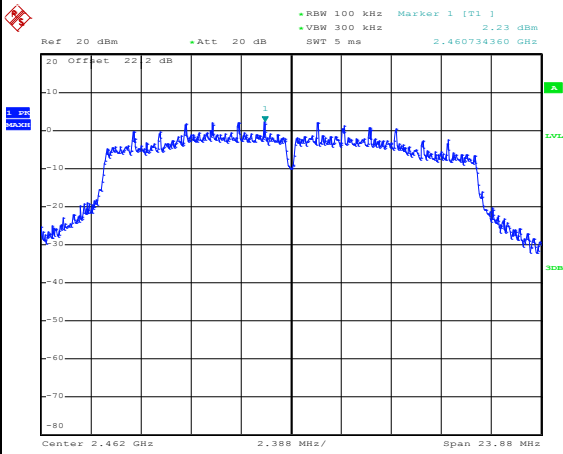

Date: 21.JAN.2019 11:23:02

Channel Plot

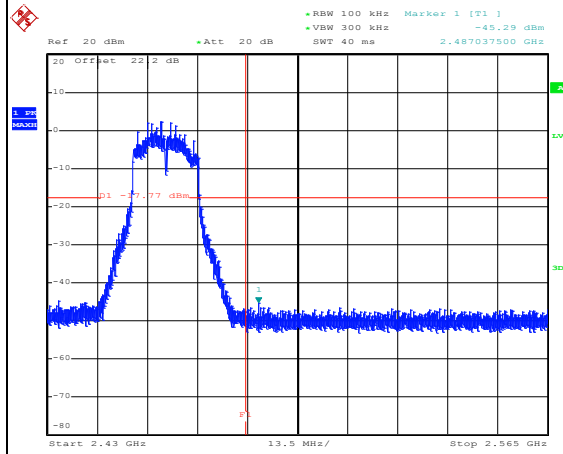

Date: 21.JAN.2019 11:23:48

Spurious Emission 30MHz~3GHz

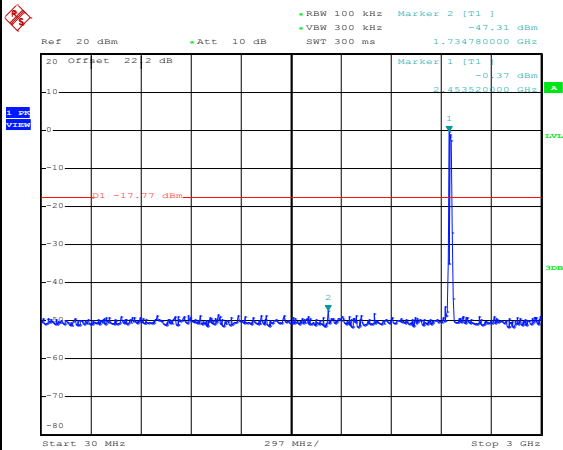

Date: 21.JAN.2019 11:24:31

Spurious Emission 2GHz~25GHz

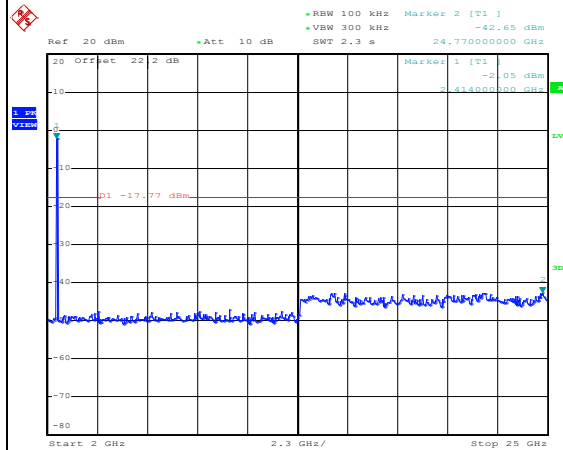

Date: 21.JAN.2019 11:24:49



WLAN 802.11n HT40 Channel 03

100kHz PSD reference Level

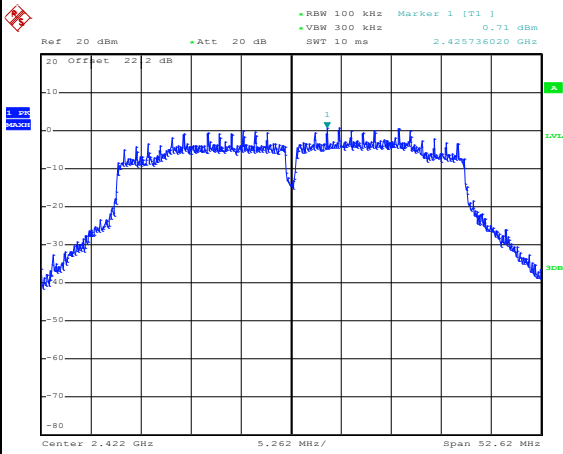

Date: 21.JAN.2019 13:50:25

Channel Plot

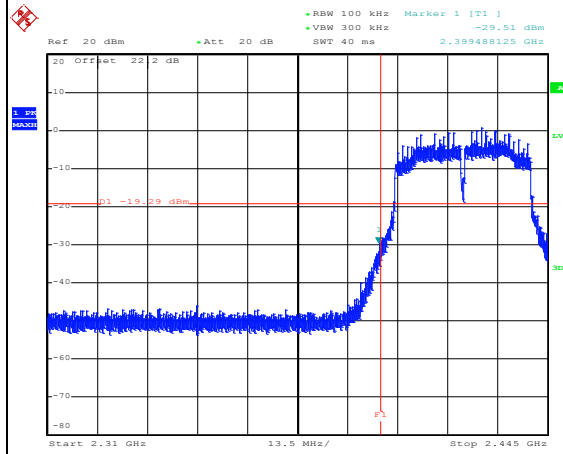

Date: 21.JAN.2019 13:50:41

Spurious Emission 30MHz~3GHz

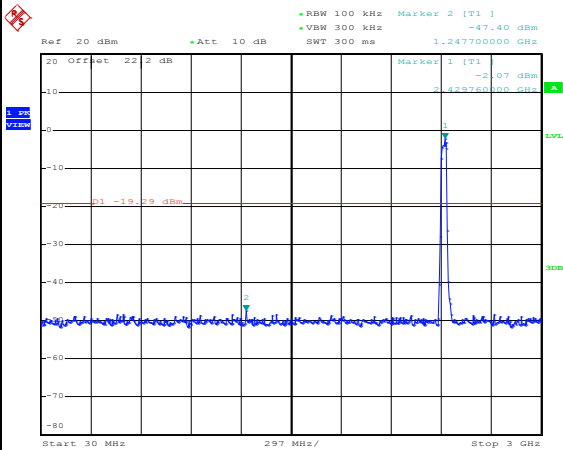

Date: 21.JAN.2019 13:51:15

Spurious Emission 2GHz~25GHz

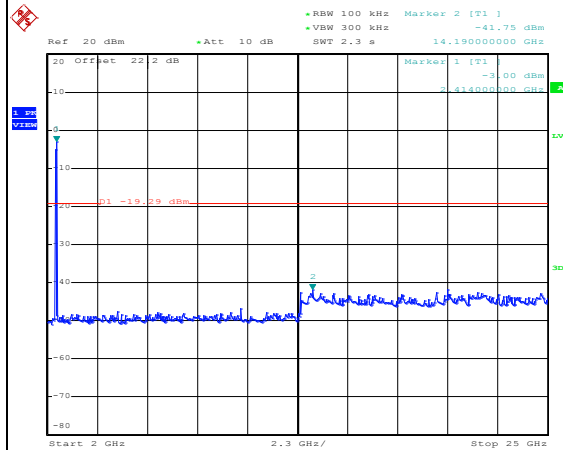

Date: 21.JAN.2019 13:51:32



WLAN 802.11n HT40 Channel 06

100kHz PSD reference Level

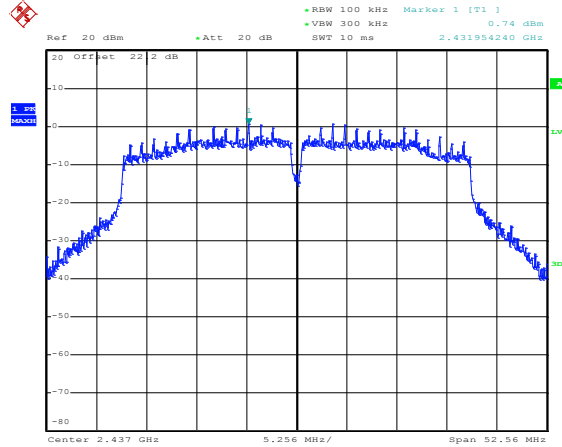

Date: 21.JAN.2019 13:54:27

Spurious Emission 30MHz~3GHz

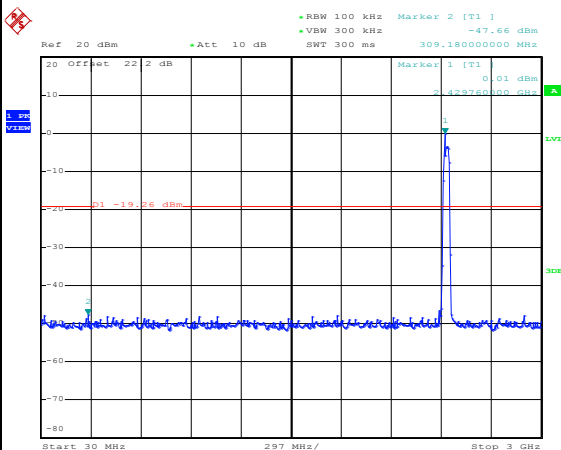

Date: 21.JAN.2019 13:54:55

Spurious Emission 2GHz~25GHz

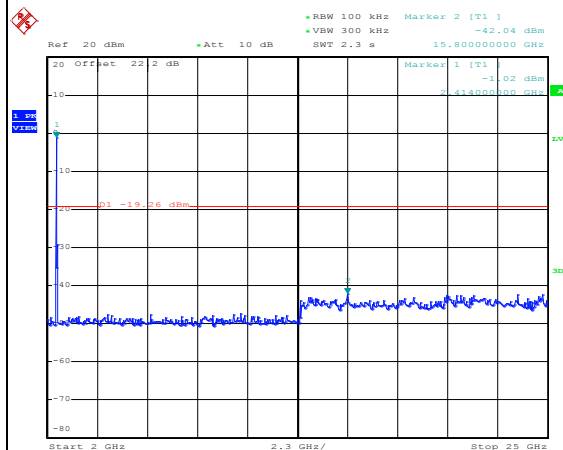

Date: 21.JAN.2019 13:55:14

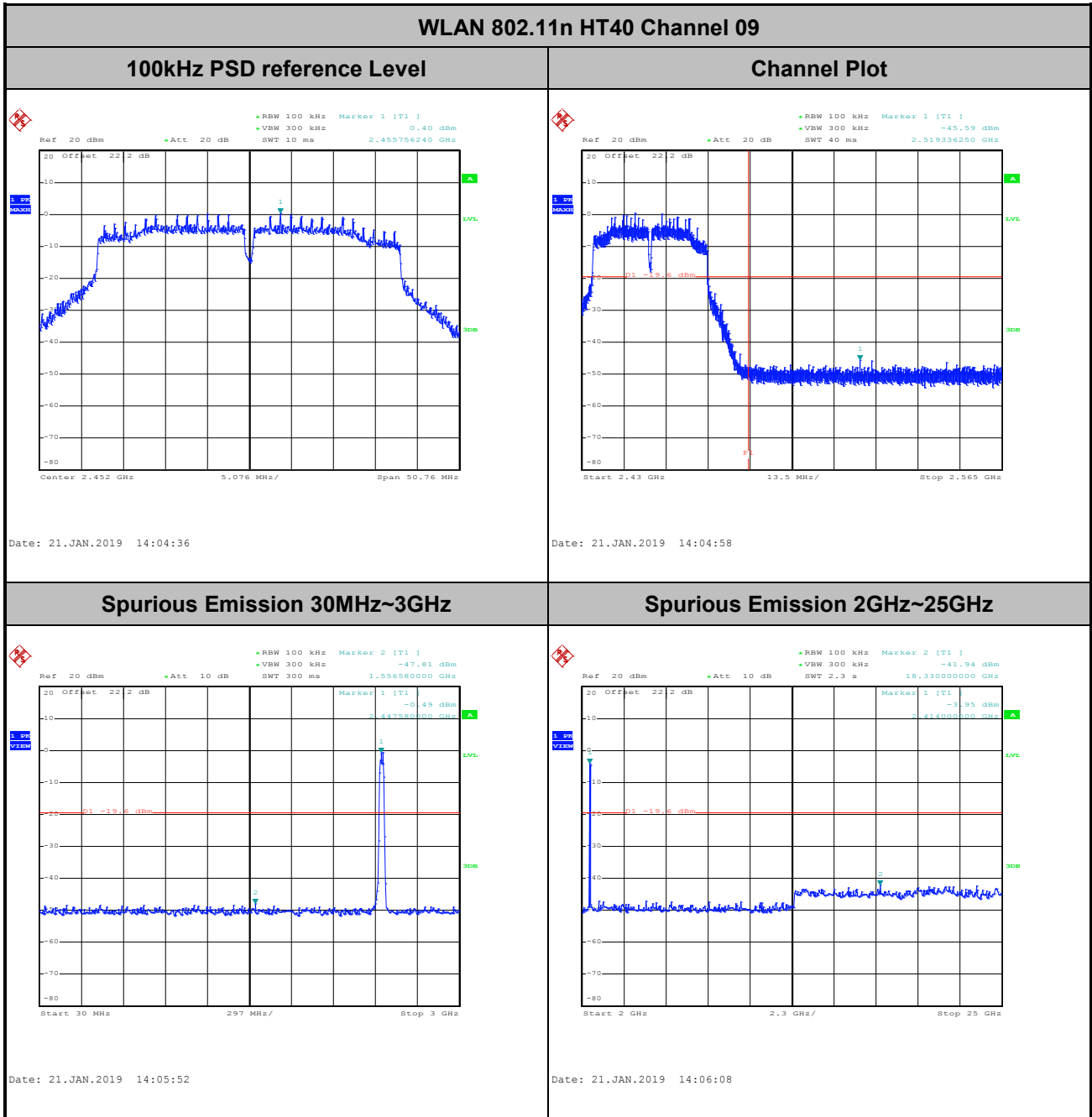



Number of TX = 1, Ant. 2 (Measured)

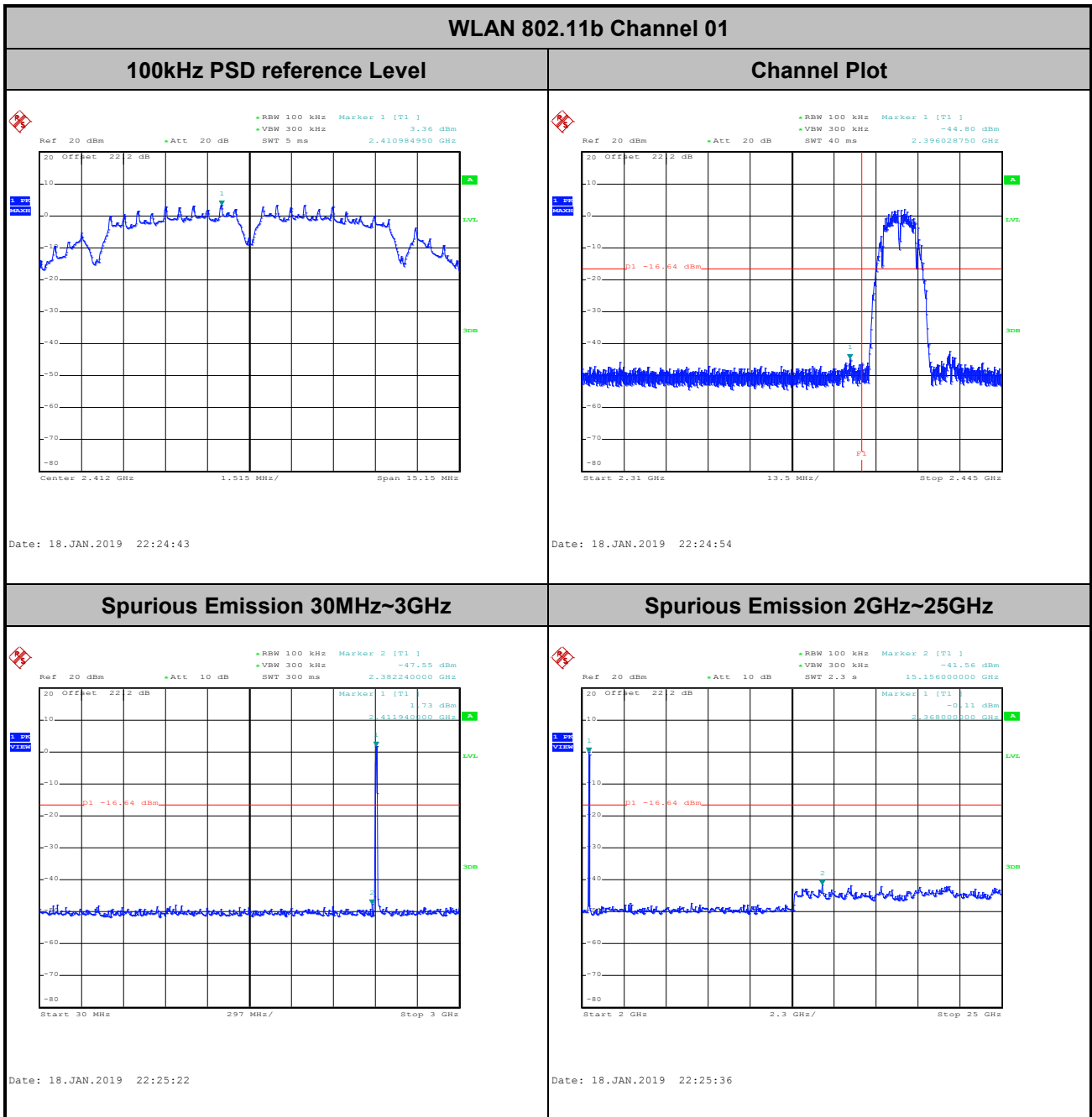



WLAN 802.11b Channel 06

100kHz PSD reference Level

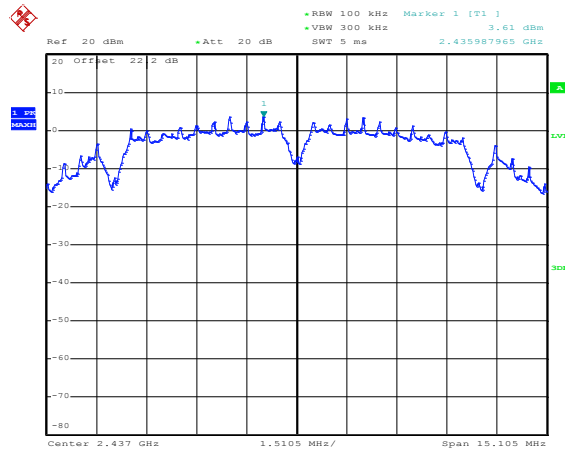

Date: 18.JAN.2019 22:29:14

Spurious Emission 30MHz~3GHz

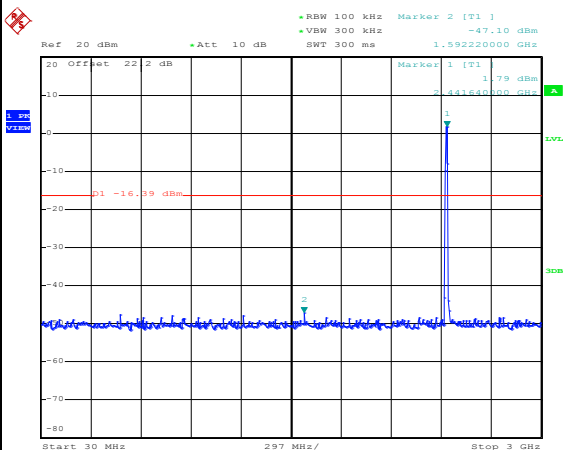

Date: 18.JAN.2019 22:29:30

Spurious Emission 2GHz~25GHz

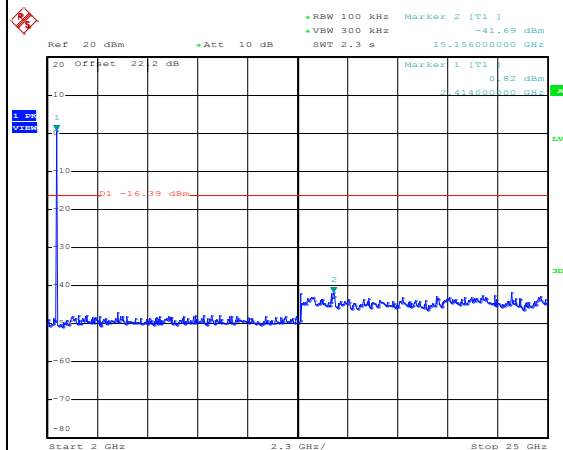

Date: 18.JAN.2019 22:29:44



WLAN 802.11b Channel 11

100kHz PSD reference Level

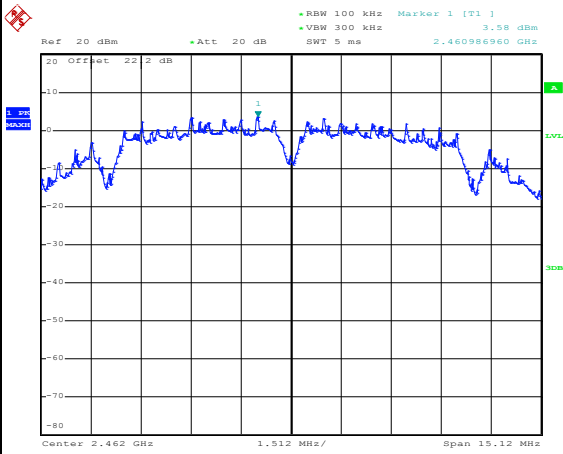

Date: 18.JAN.2019 22:32:07

Channel Plot

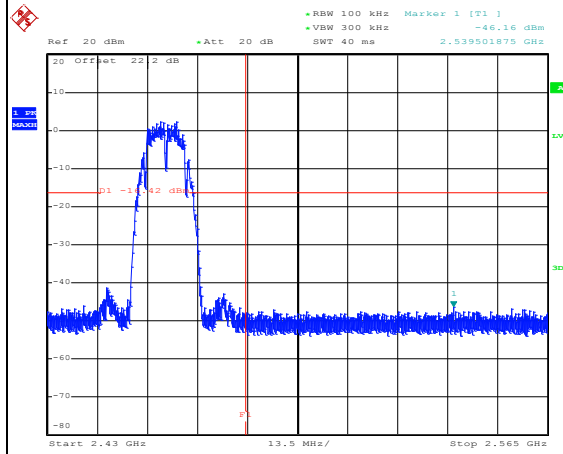

Date: 18.JAN.2019 22:32:19

Spurious Emission 30MHz~3GHz

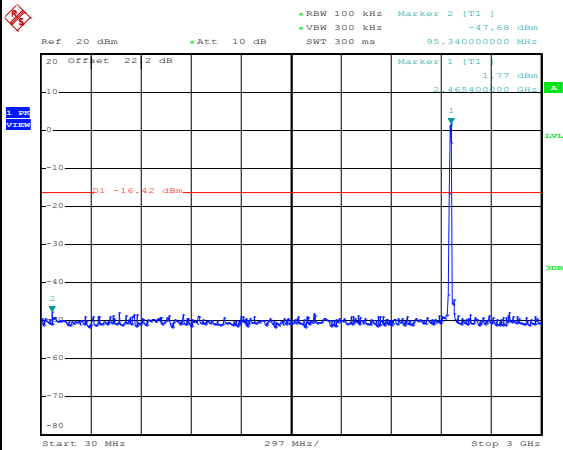

Date: 18.JAN.2019 22:32:38

Spurious Emission 2GHz~25GHz

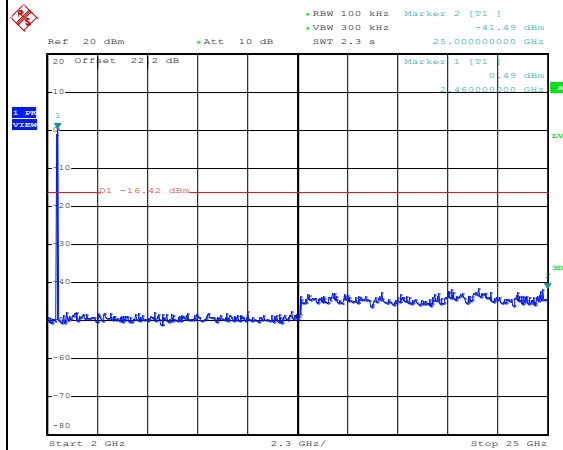

Date: 18.JAN.2019 22:32:59



WLAN 802.11g Channel 01

100kHz PSD reference Level

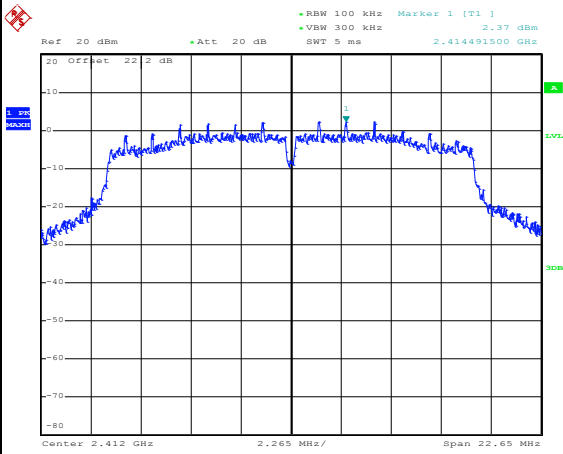

Date: 18.JAN.2019 23:54:31

Channel Plot

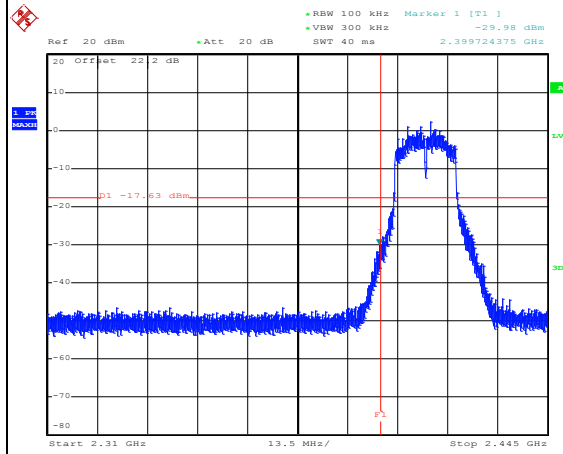

Date: 18.JAN.2019 23:54:44

Spurious Emission 30MHz~3GHz

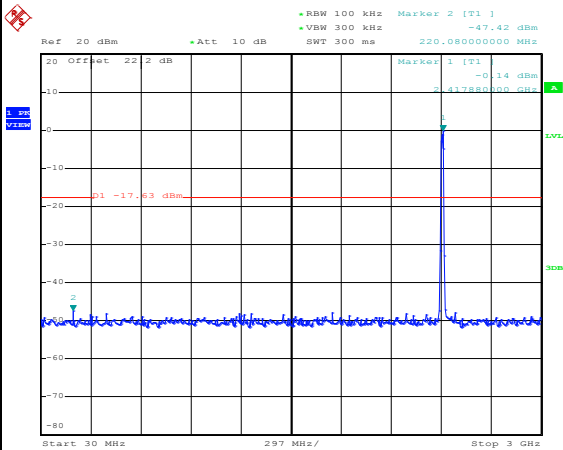

Date: 18.JAN.2019 23:55:09

Spurious Emission 2GHz~25GHz

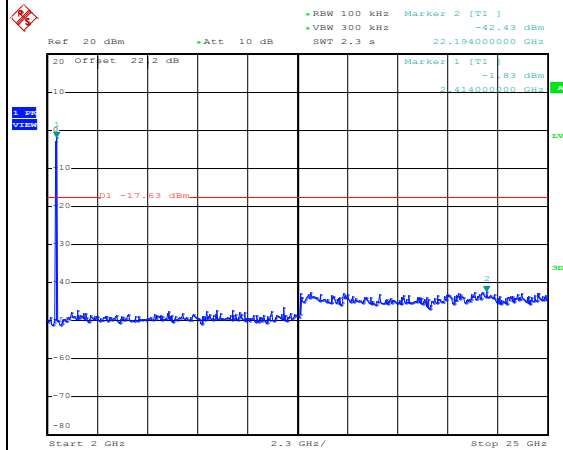

Date: 18.JAN.2019 23:55:29



WLAN 802.11g Channel 06

100kHz PSD reference Level

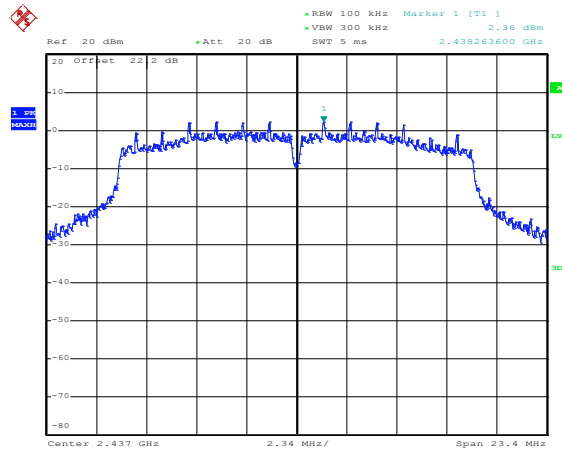

Date: 18.JAN.2019 23:58:44

Spurious Emission 30MHz~3GHz

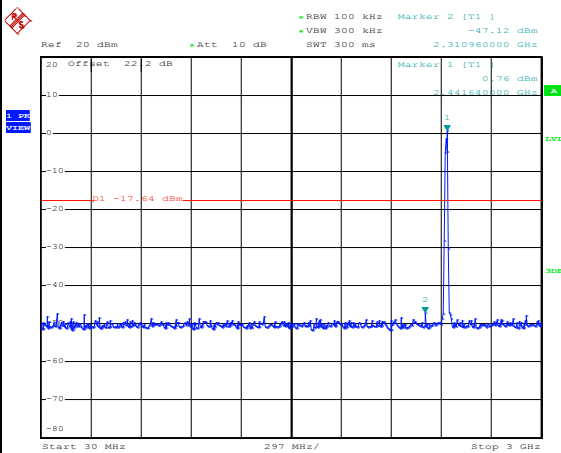

Date: 18.JAN.2019 23:58:59

Spurious Emission 2GHz~25GHz

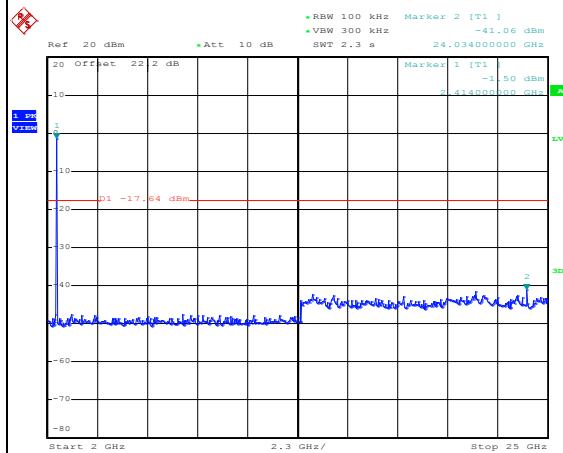

Date: 18.JAN.2019 23:59:16



WLAN 802.11g Channel 11

100kHz PSD reference Level

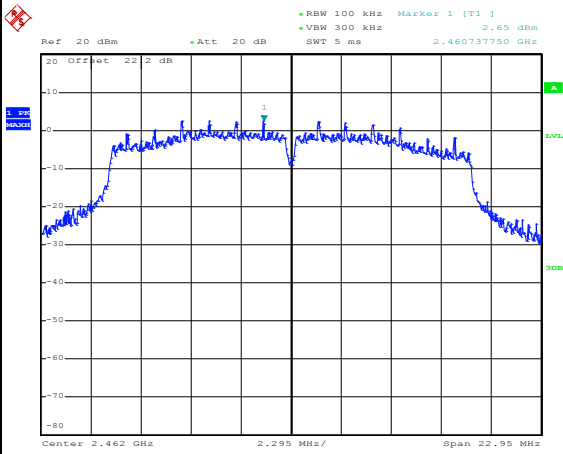

Date: 19.JAN.2019 00:28:21

Channel Plot

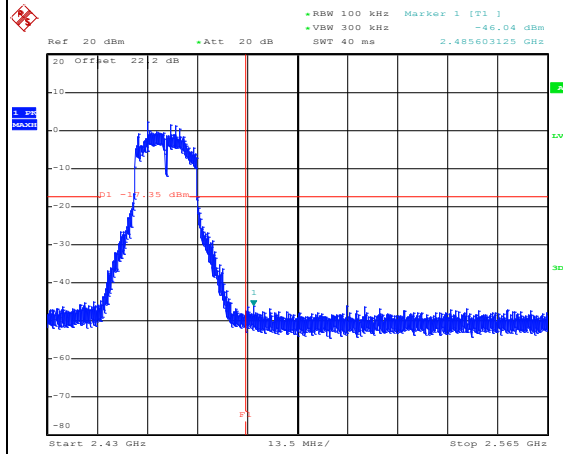

Date: 19.JAN.2019 00:28:35

Spurious Emission 30MHz~3GHz

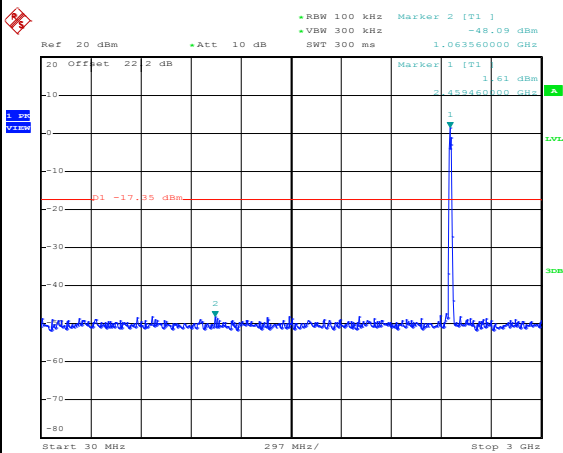

Date: 19.JAN.2019 00:29:03

Spurious Emission 2GHz~25GHz

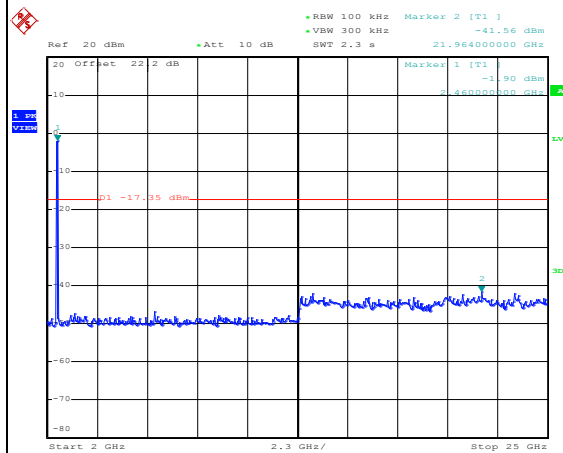

Date: 19.JAN.2019 00:29:18

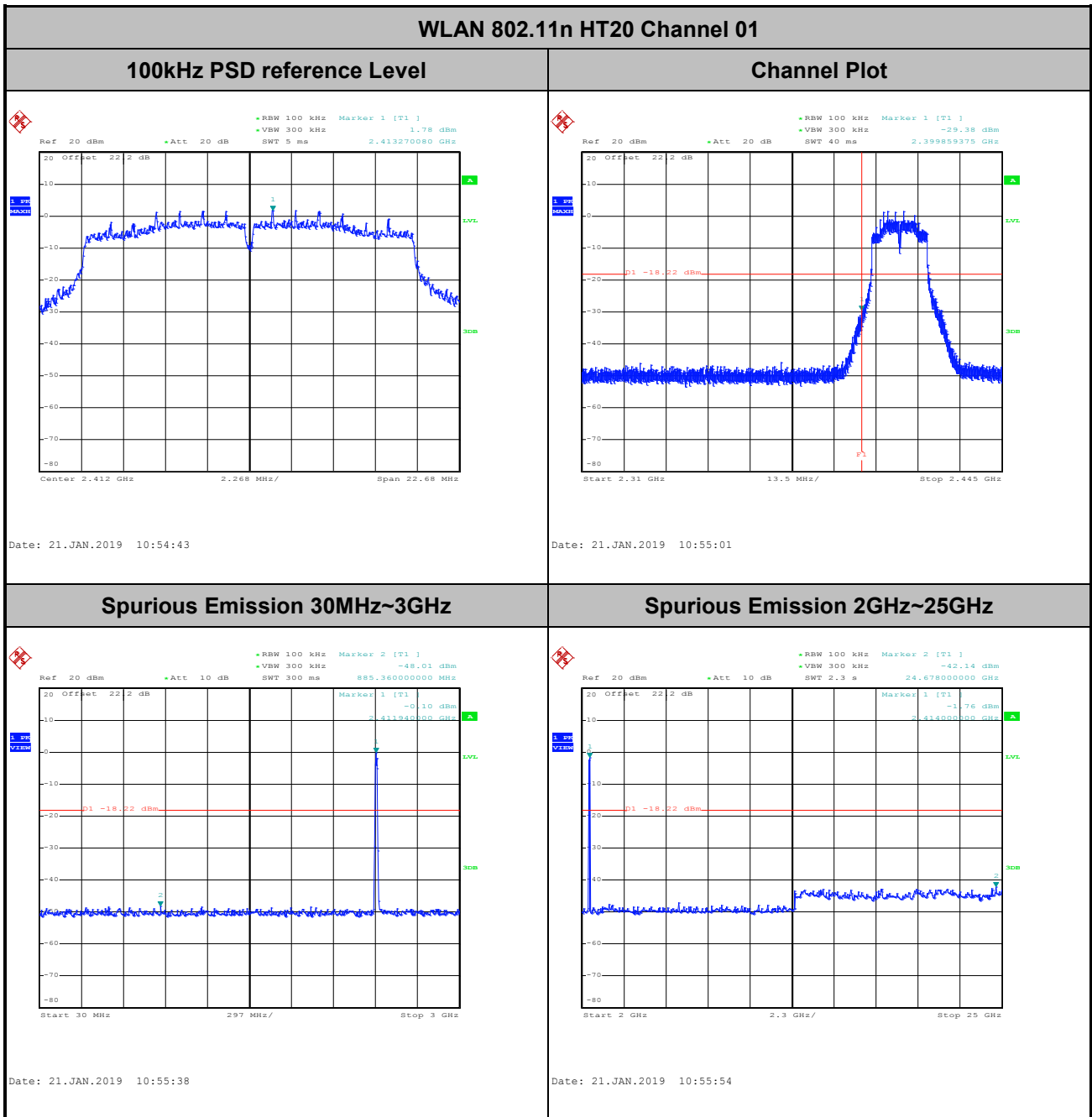



WLAN 802.11n HT20 Channel 06

100kHz PSD reference Level

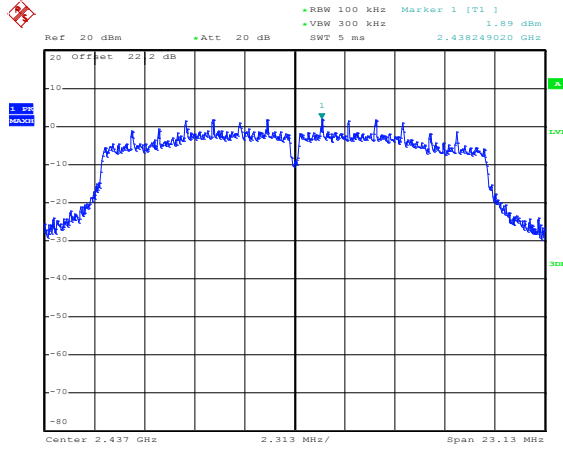

Date: 21.JAN.2019 11:15:31

Spurious Emission 30MHz~3GHz

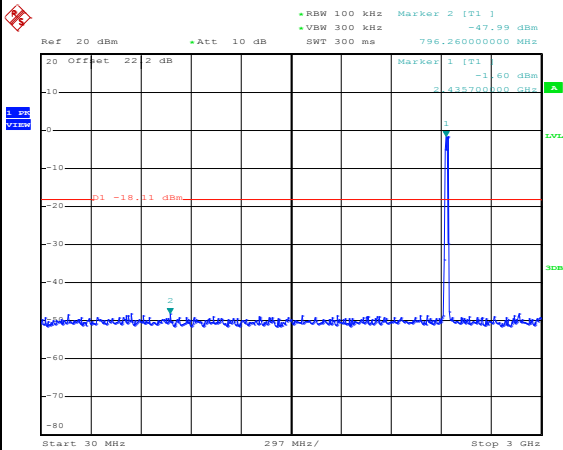

Date: 21.JAN.2019 11:15:57

Spurious Emission 2GHz~25GHz

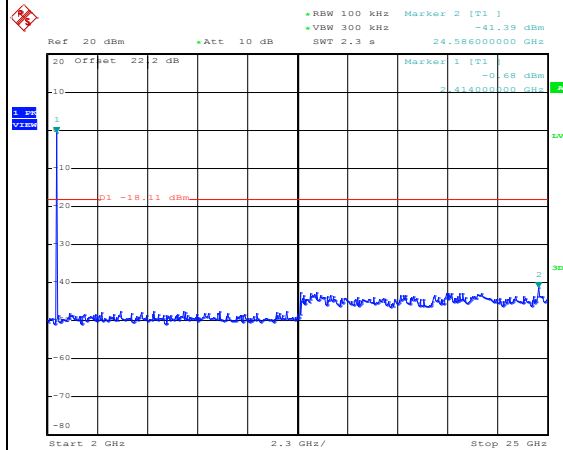

Date: 21.JAN.2019 11:16:21

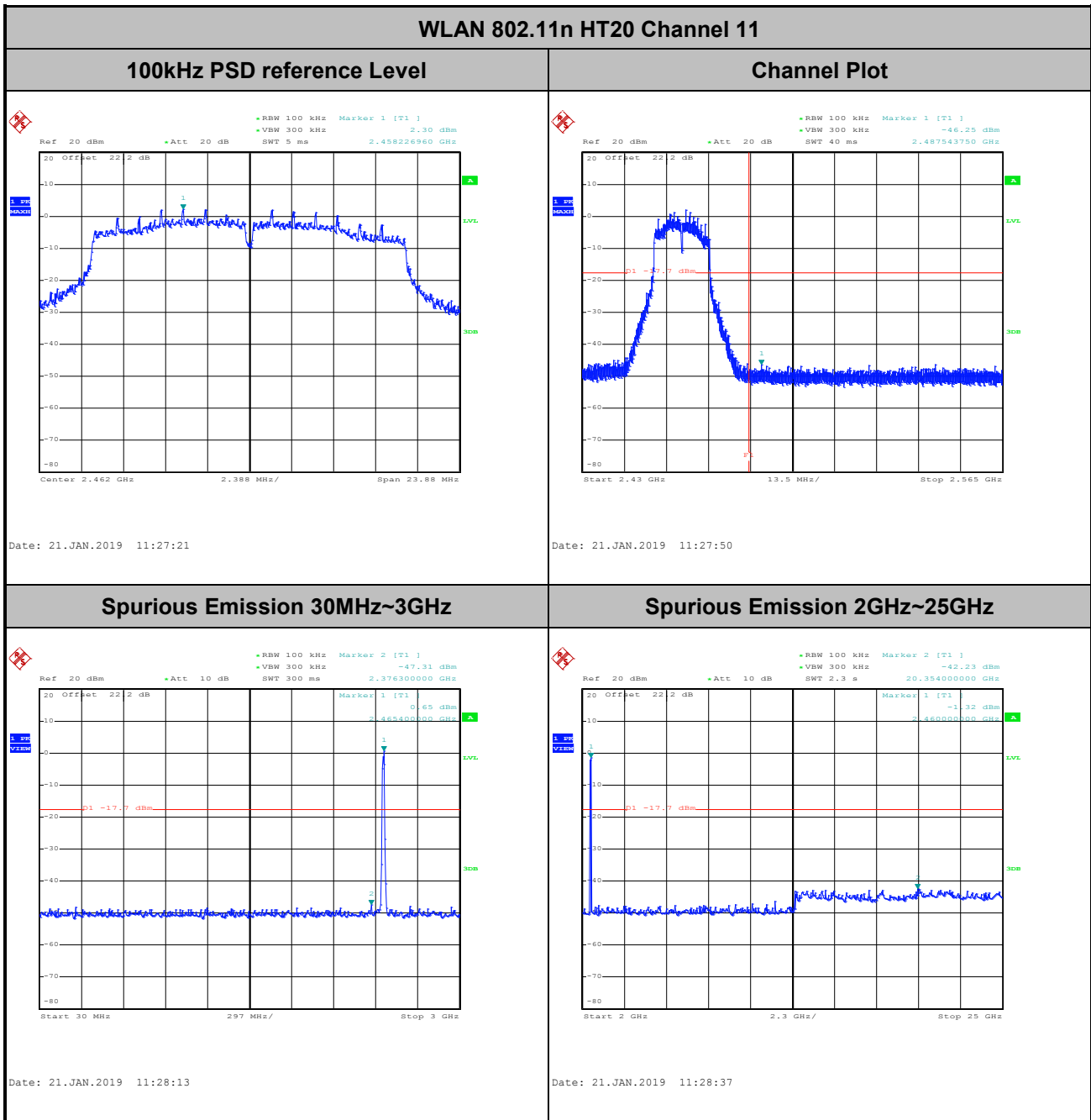



WLAN 802.11n HT40 Channel 03

100kHz PSD reference Level

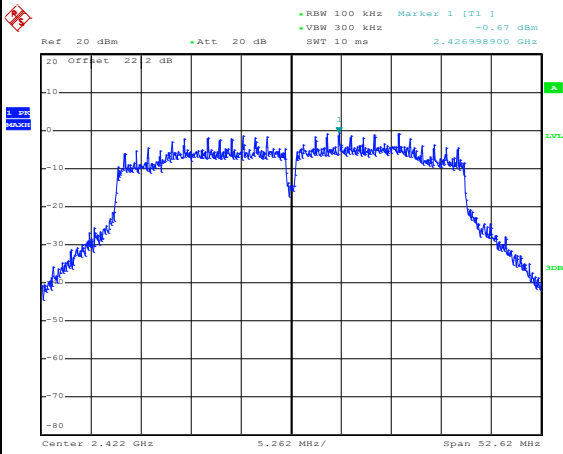

Date: 21.JAN.2019 14:11:04

Channel Plot

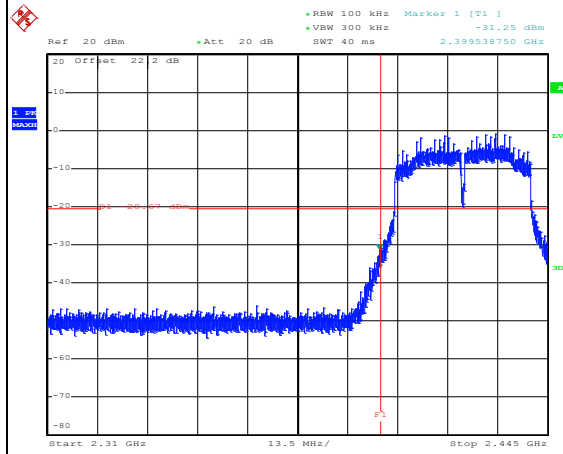

Date: 21.JAN.2019 14:11:18

Spurious Emission 30MHz~3GHz

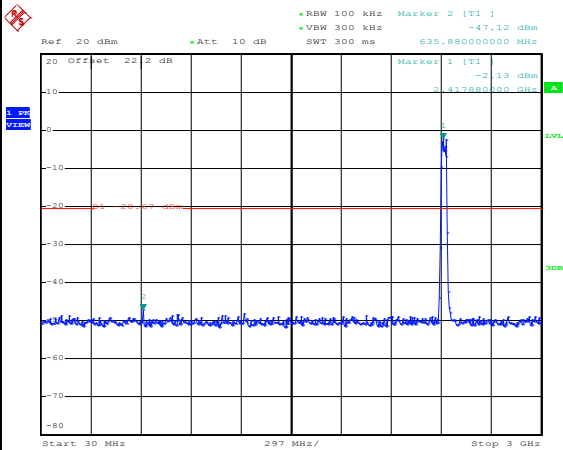

Date: 21.JAN.2019 14:12:08

Spurious Emission 2GHz~25GHz

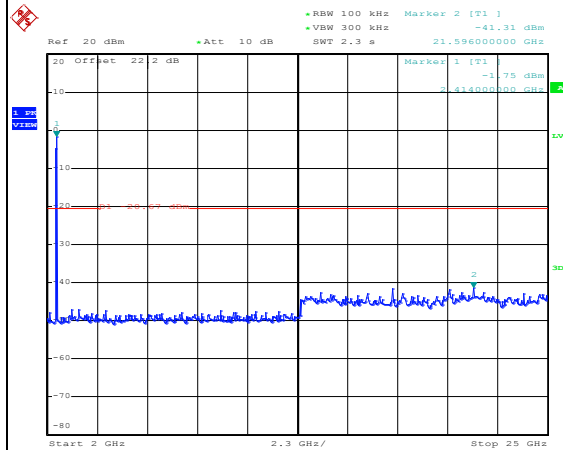

Date: 21.JAN.2019 14:12:25



WLAN 802.11n HT40 Channel 06

100kHz PSD reference Level

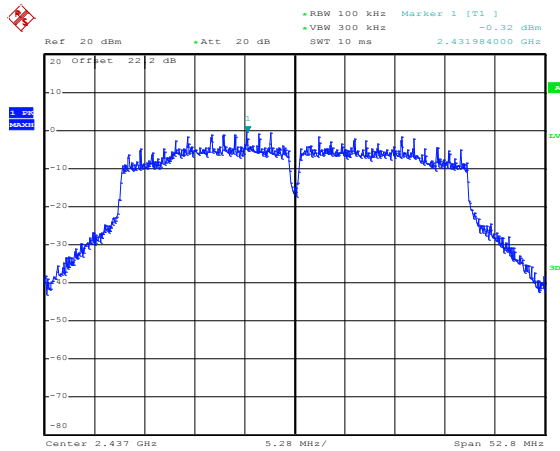

Date: 21.JAN.2019 14:16:06

Spurious Emission 30MHz~3GHz

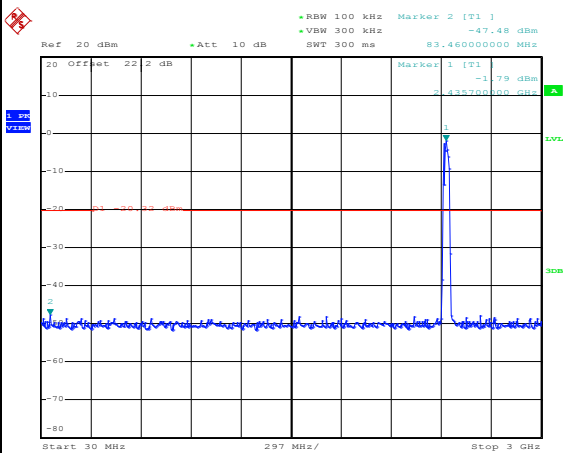

Date: 21.JAN.2019 14:16:25

Spurious Emission 2GHz~25GHz

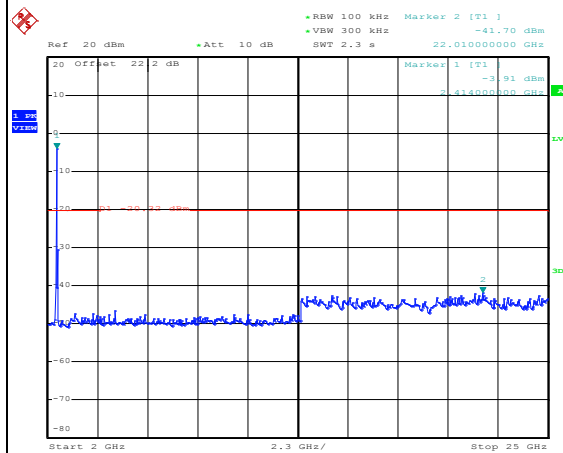

Date: 21.JAN.2019 14:16:47



WLAN 802.11n HT40 Channel 09

100kHz PSD reference Level

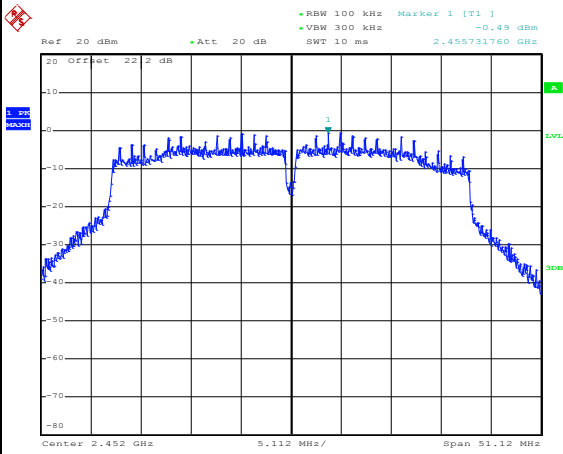

Date: 21.JAN.2019 14:19:24

Channel Plot

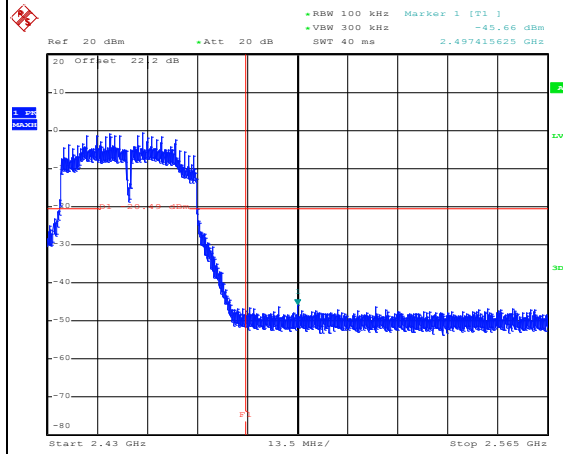

Date: 21.JAN.2019 14:20:12

Spurious Emission 30MHz~3GHz

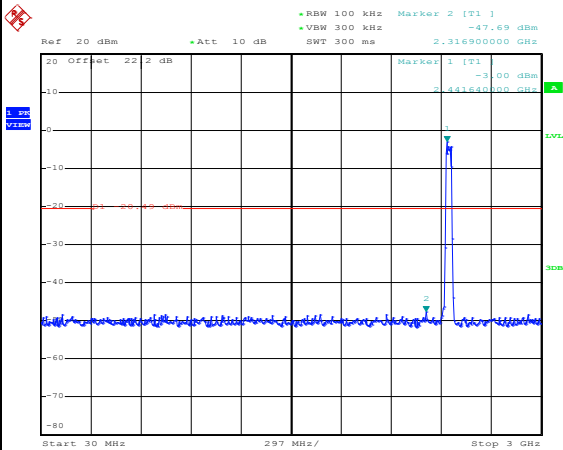

Date: 21.JAN.2019 14:20:36

Spurious Emission 2GHz~25GHz

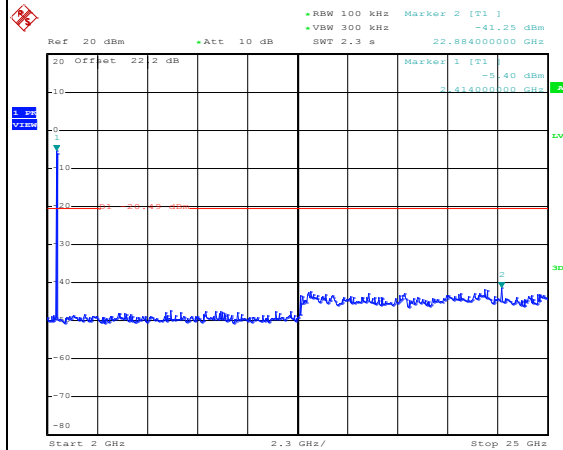

Date: 21.JAN.2019 14:20:51



Number of TX = 2, Ant. 1 (Measured)

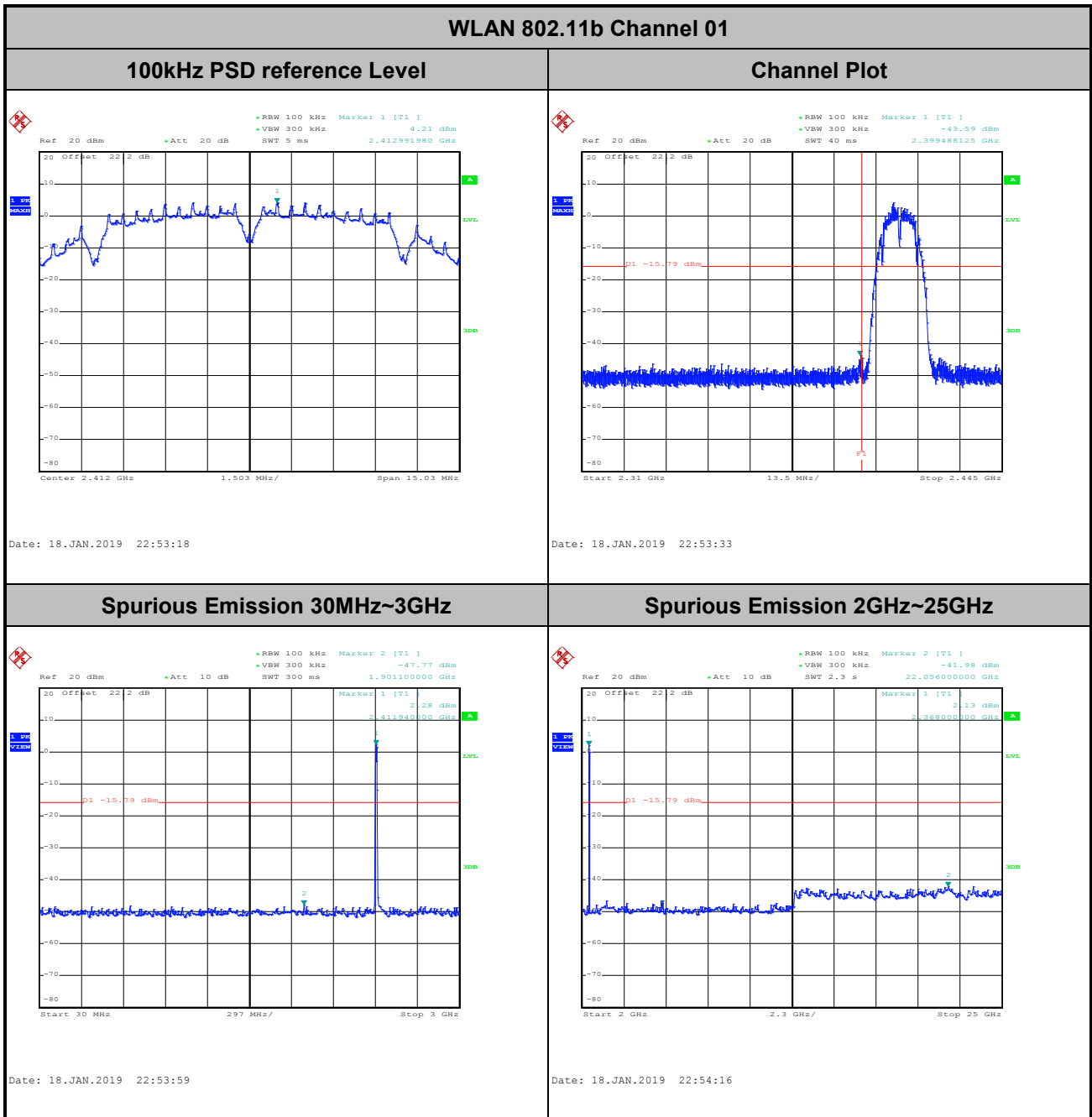



WLAN 802.11b Channel 06

100kHz PSD reference Level

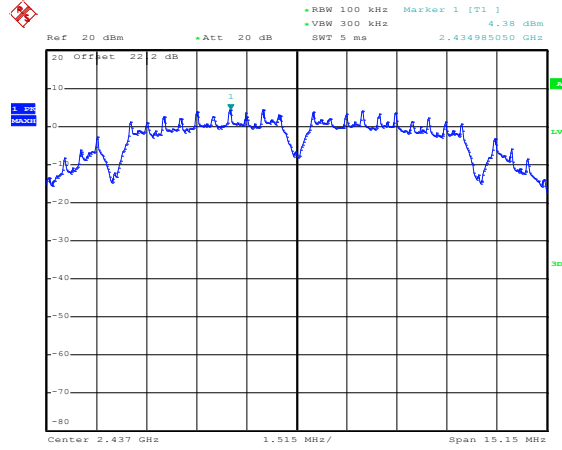

Date: 18.JAN.2019 23:06:24

Spurious Emission 30MHz~3GHz

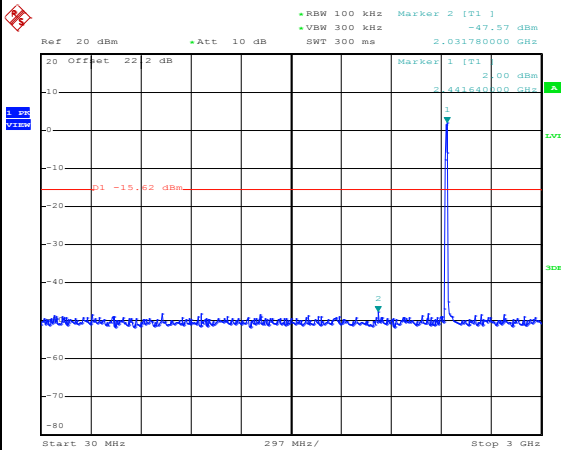

Date: 18.JAN.2019 23:06:47

Spurious Emission 2GHz~25GHz

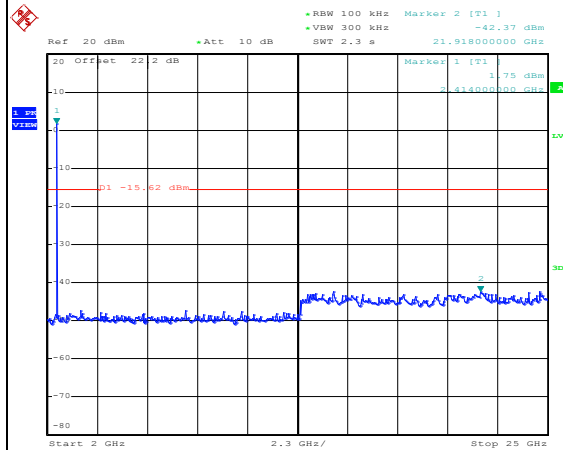

Date: 18.JAN.2019 23:07:04



WLAN 802.11b Channel 11

100kHz PSD reference Level

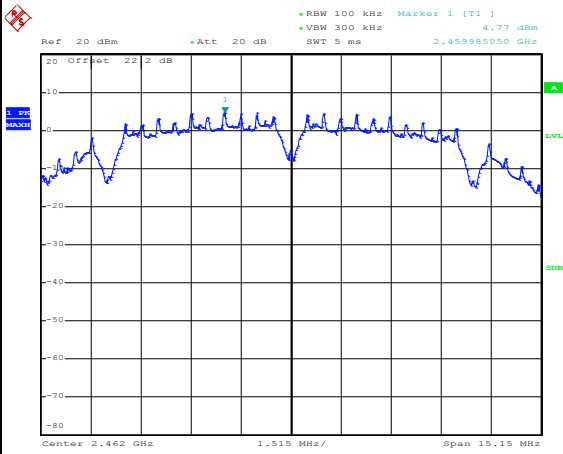

Date: 18.JAN.2019 23:18:47

Channel Plot

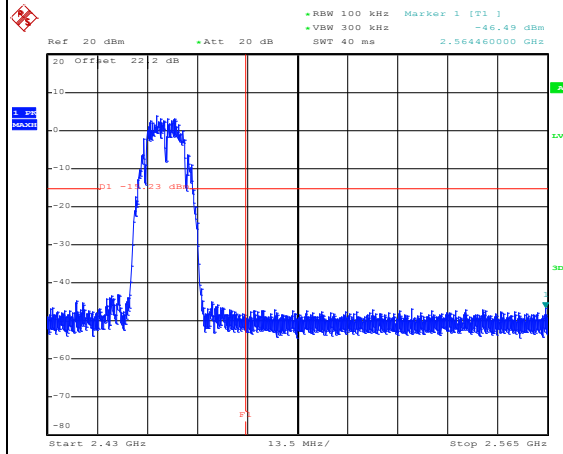

Date: 18.JAN.2019 23:19:00

Spurious Emission 30MHz~3GHz

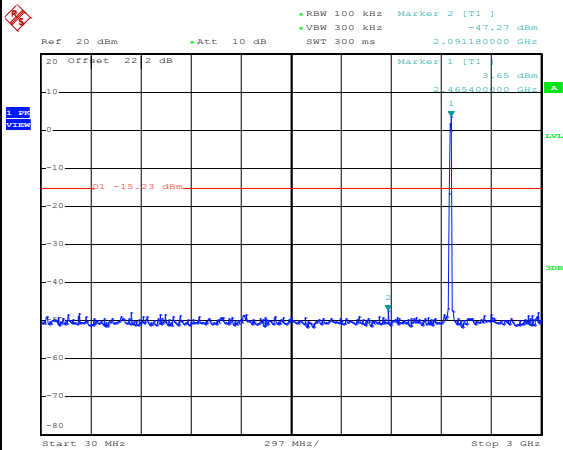

Date: 18.JAN.2019 23:19:22

Spurious Emission 2GHz~25GHz

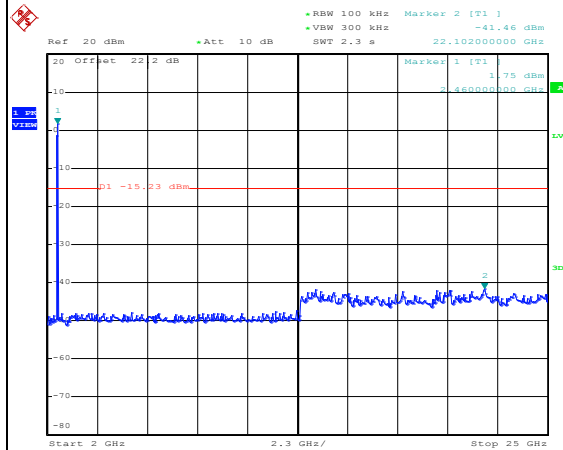

Date: 18.JAN.2019 23:19:37



WLAN 802.11g Channel 01

100kHz PSD reference Level

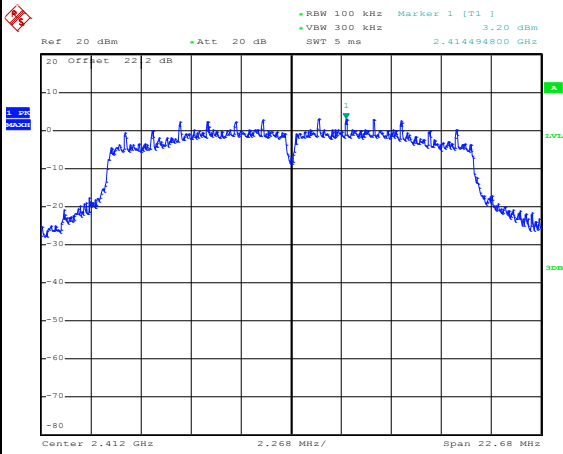

Date: 21.JAN.2019 09:09:34

Channel Plot

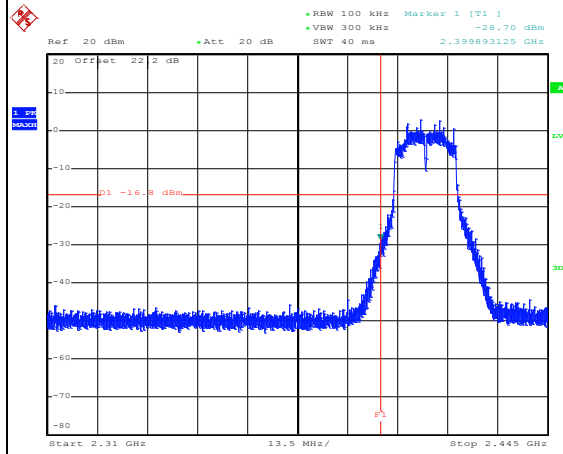

Date: 21.JAN.2019 09:10:02

Spurious Emission 30MHz~3GHz

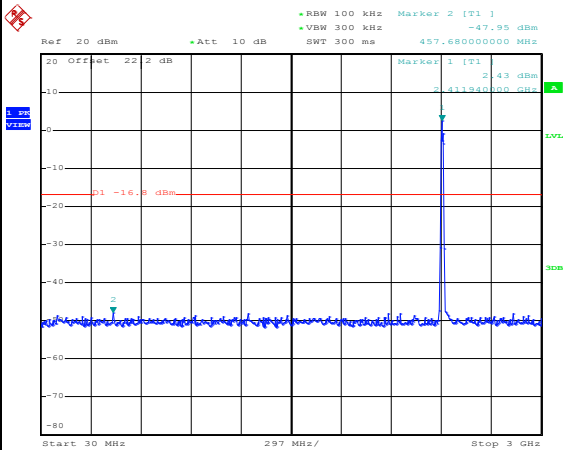

Date: 21.JAN.2019 09:10:46

Spurious Emission 2GHz~25GHz

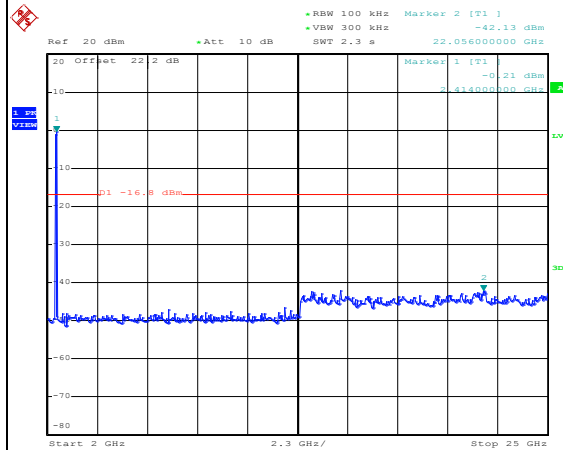

Date: 21.JAN.2019 09:11:08



WLAN 802.11g Channel 06

100kHz PSD reference Level

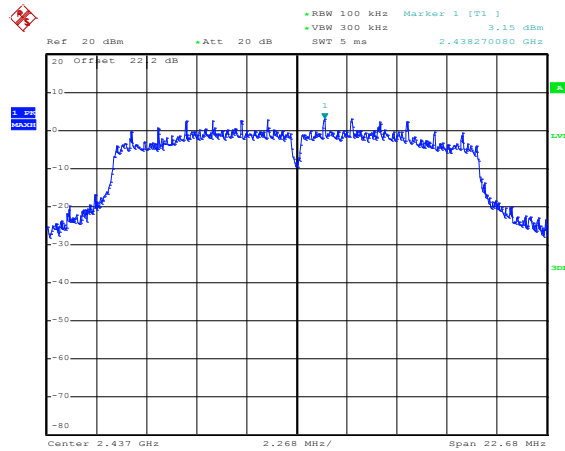

Date: 21.JAN.2019 09:26:42

Spurious Emission 30MHz~3GHz

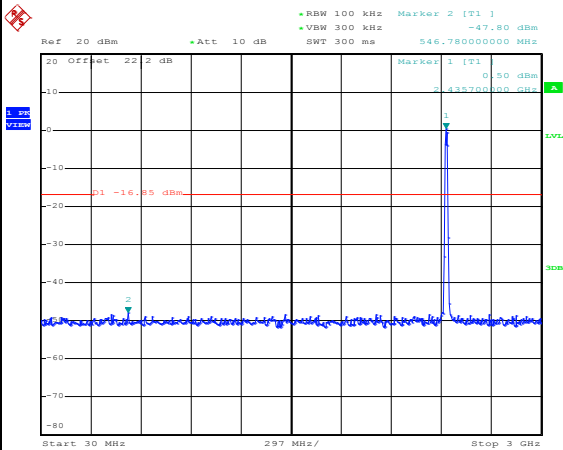

Date: 21.JAN.2019 09:26:59

Spurious Emission 2GHz~25GHz

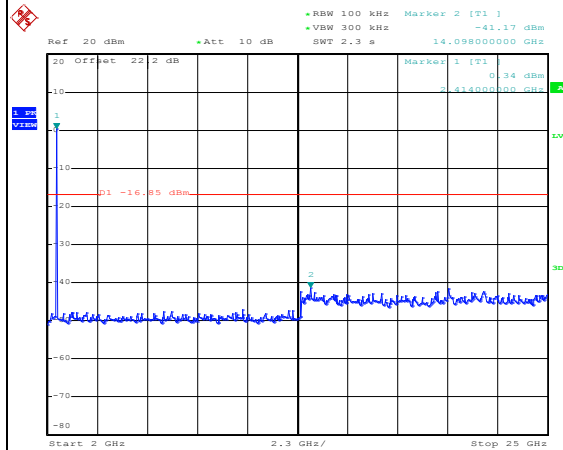

Date: 21.JAN.2019 09:27:12



WLAN 802.11g Channel 11

100kHz PSD reference Level

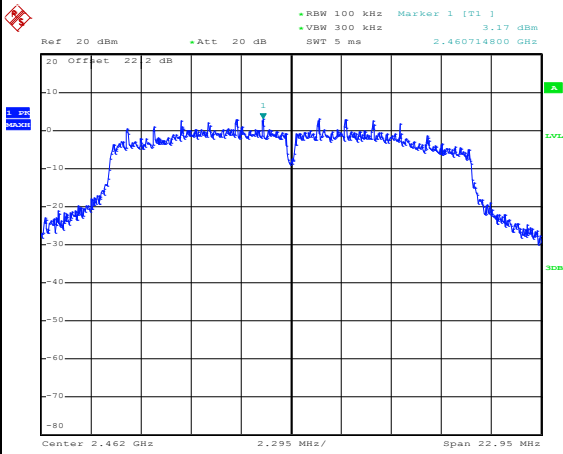

Date: 21.JAN.2019 09:36:48

Channel Plot

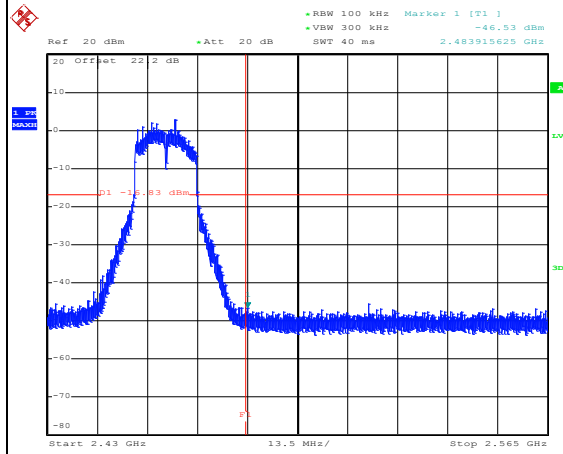

Date: 21.JAN.2019 09:37:02

Spurious Emission 30MHz~3GHz

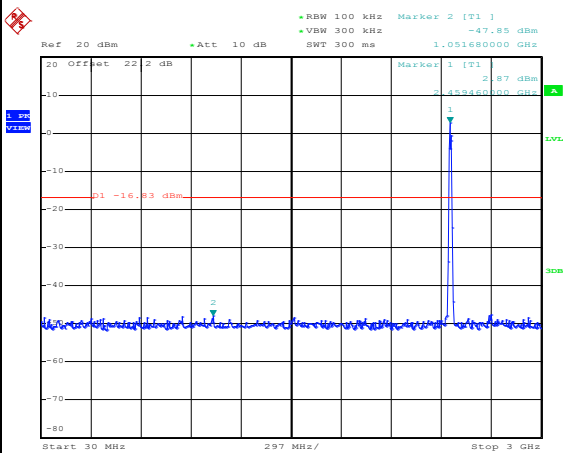

Date: 21.JAN.2019 09:37:32

Spurious Emission 2GHz~25GHz

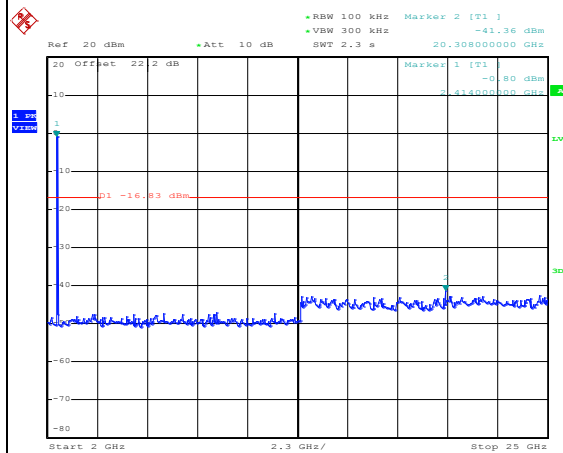

Date: 21.JAN.2019 09:37:46

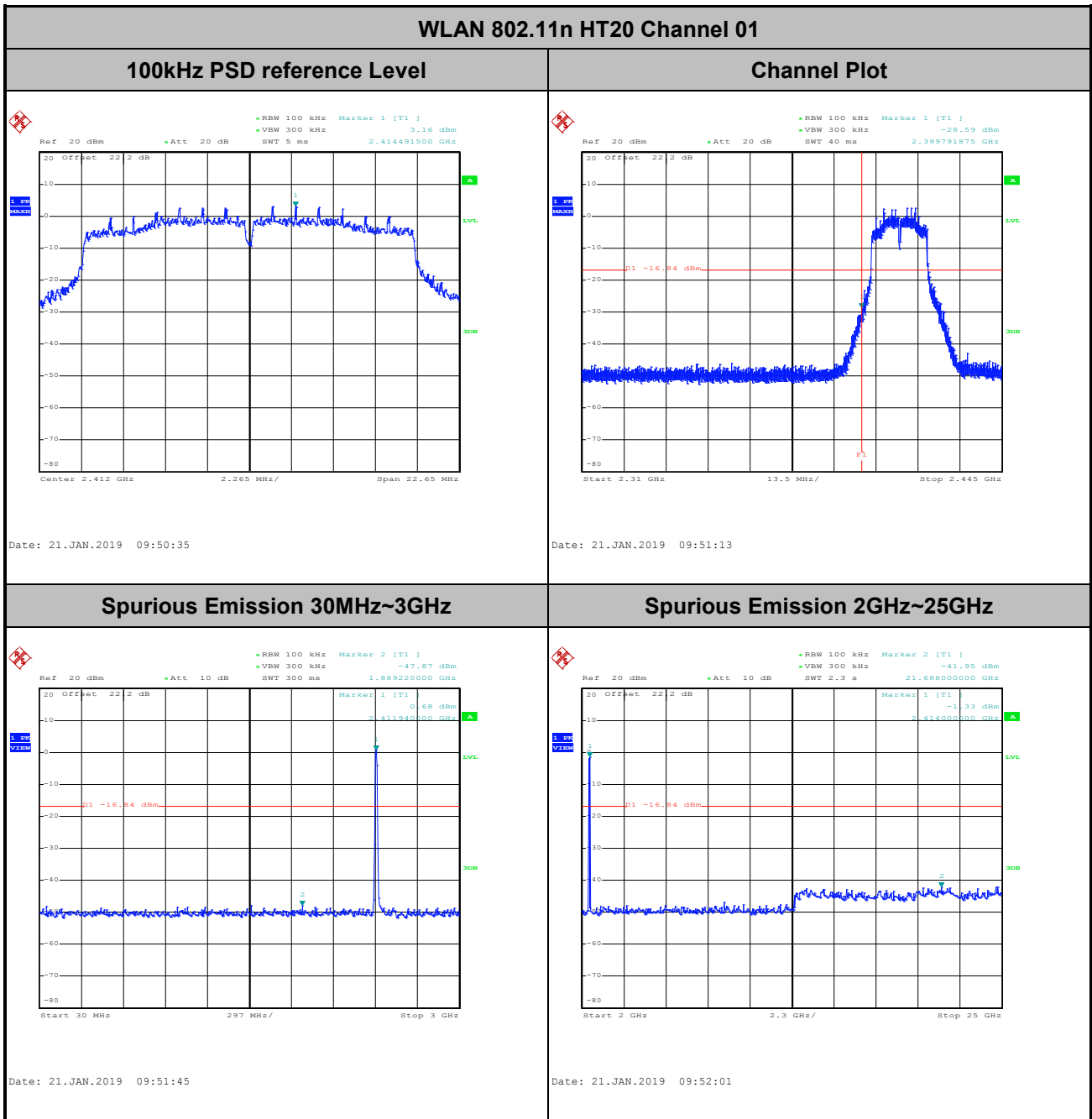



WLAN 802.11n HT20 Channel 06

100kHz PSD reference Level

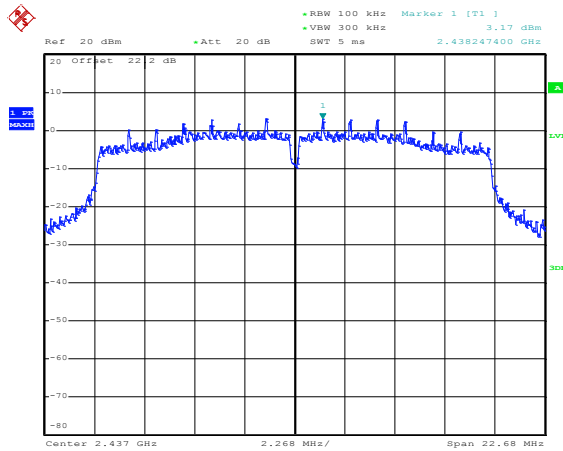

Date: 21.JAN.2019 10:01:48

Spurious Emission 30MHz~3GHz

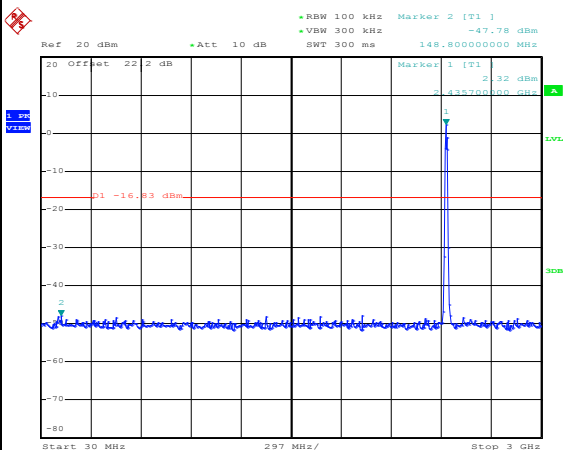

Date: 21.JAN.2019 10:02:44

Spurious Emission 2GHz~25GHz

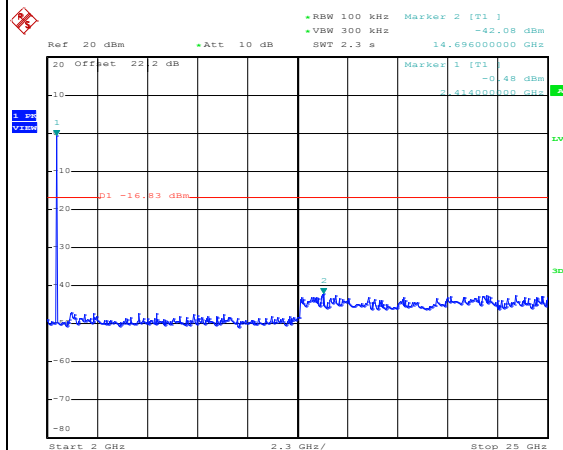

Date: 21.JAN.2019 10:03:00



WLAN 802.11n HT20 Channel 11

100kHz PSD reference Level

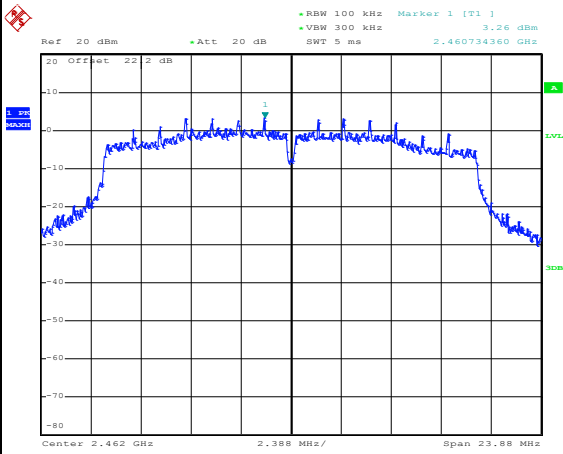

Date: 21.JAN.2019 10:19:44

Channel Plot

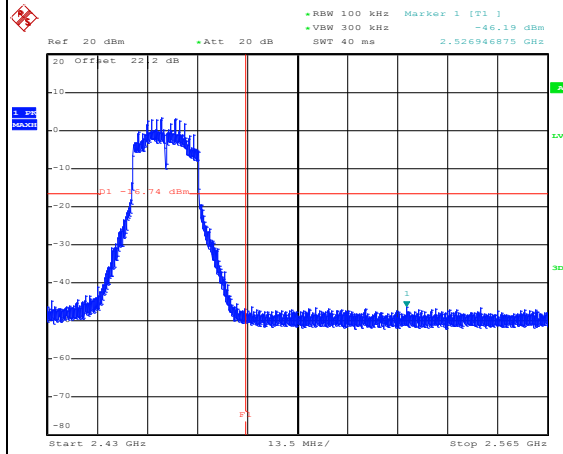

Date: 21.JAN.2019 10:21:04

Spurious Emission 30MHz~3GHz

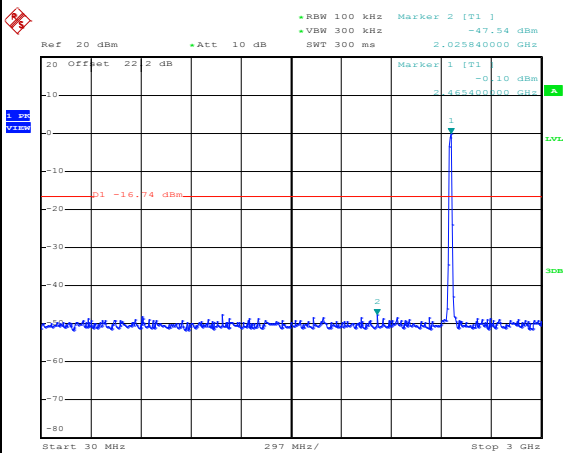

Date: 21.JAN.2019 10:21:38

Spurious Emission 2GHz~25GHz

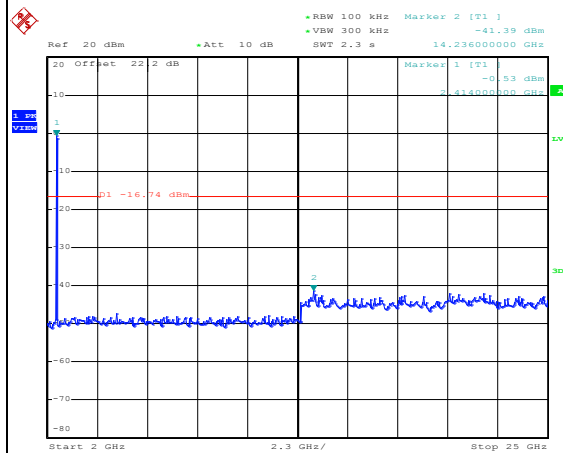

Date: 21.JAN.2019 10:21:58



WLAN 802.11n HT40 Channel 03

100kHz PSD reference Level

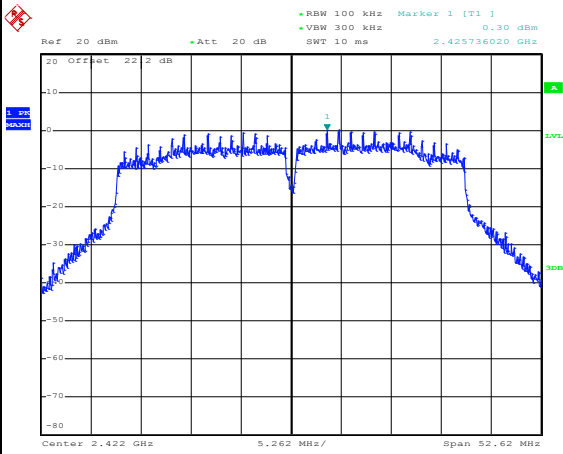

Date: 21.JAN.2019 11:35:17

Channel Plot

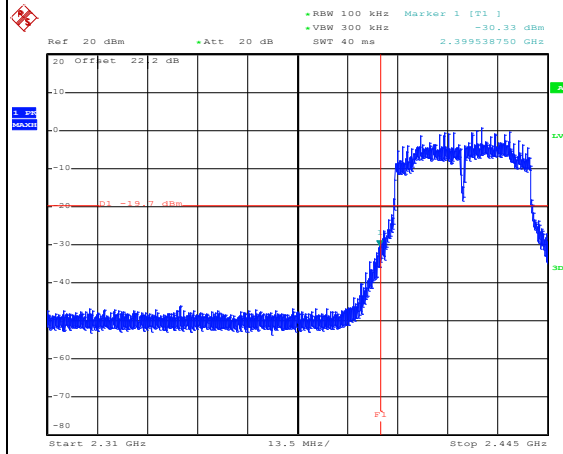

Date: 21.JAN.2019 11:35:37

Spurious Emission 30MHz~3GHz

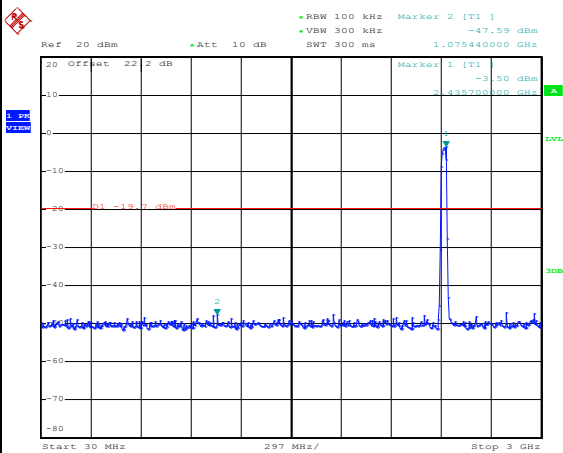

Date: 21.JAN.2019 11:36:22

Spurious Emission 2GHz~25GHz

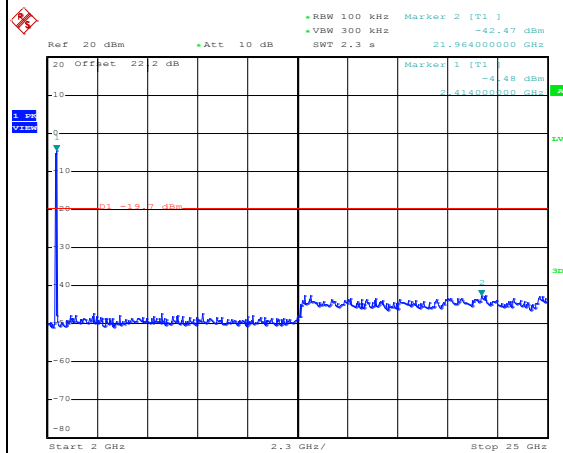

Date: 21.JAN.2019 11:36:41



WLAN 802.11n HT40 Channel 06

100kHz PSD reference Level

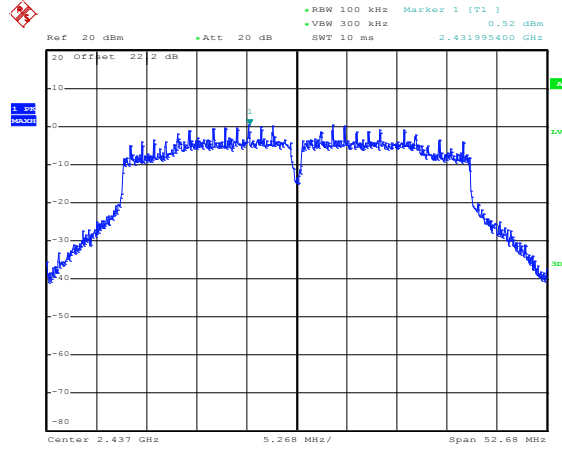

Date: 21.JAN.2019 11:49:57

Spurious Emission 30MHz~3GHz

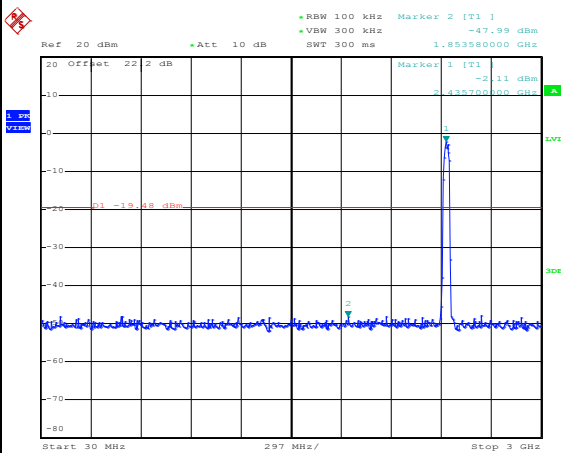

Date: 21.JAN.2019 11:50:20

Spurious Emission 2GHz~25GHz

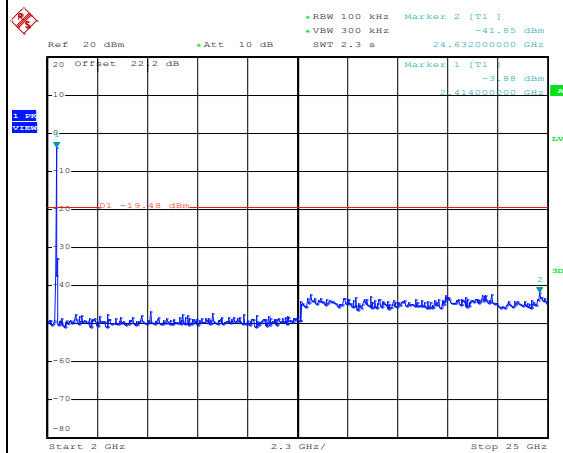

Date: 21.JAN.2019 11:50:58



WLAN 802.11n HT40 Channel 09

100kHz PSD reference Level

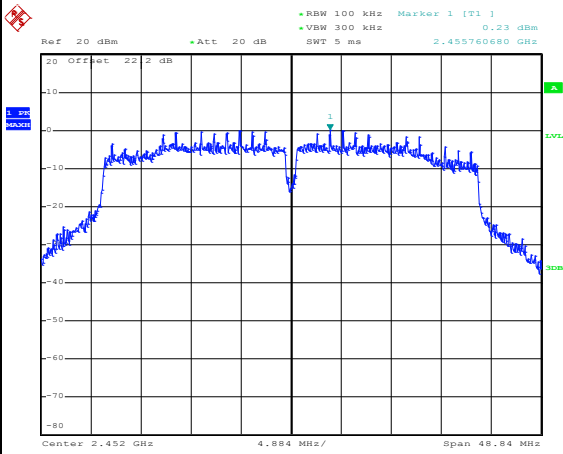

Date: 21.JAN.2019 13:42:33

Channel Plot

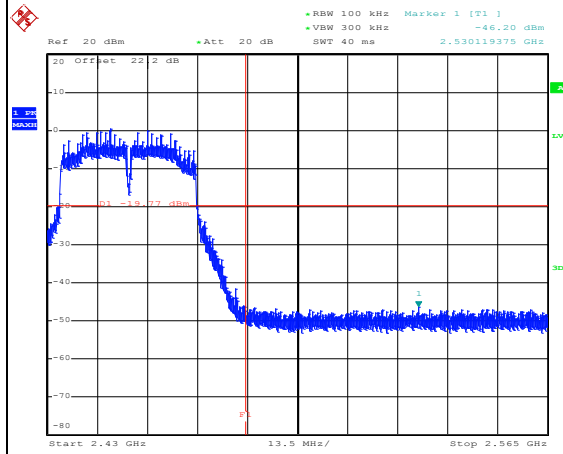

Date: 21.JAN.2019 13:43:05

Spurious Emission 30MHz~3GHz

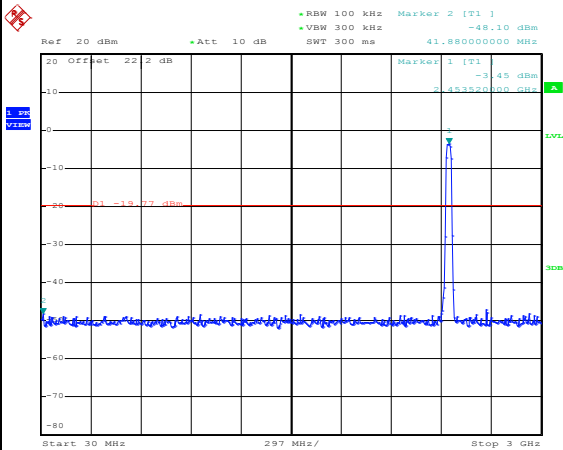

Date: 21.JAN.2019 13:43:43

Spurious Emission 2GHz~25GHz

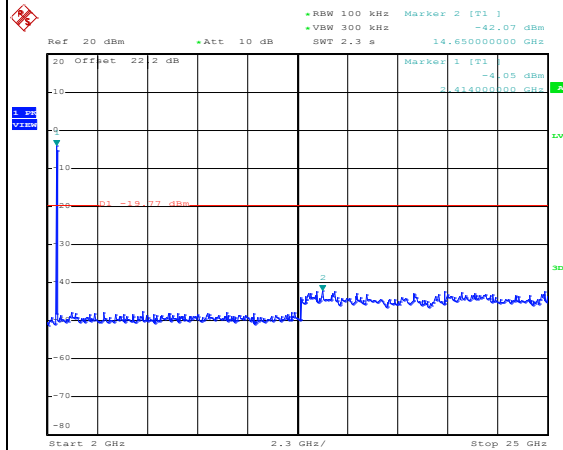

Date: 21.JAN.2019 13:43:58



Number of TX = 2, Ant. 2 (Measured)

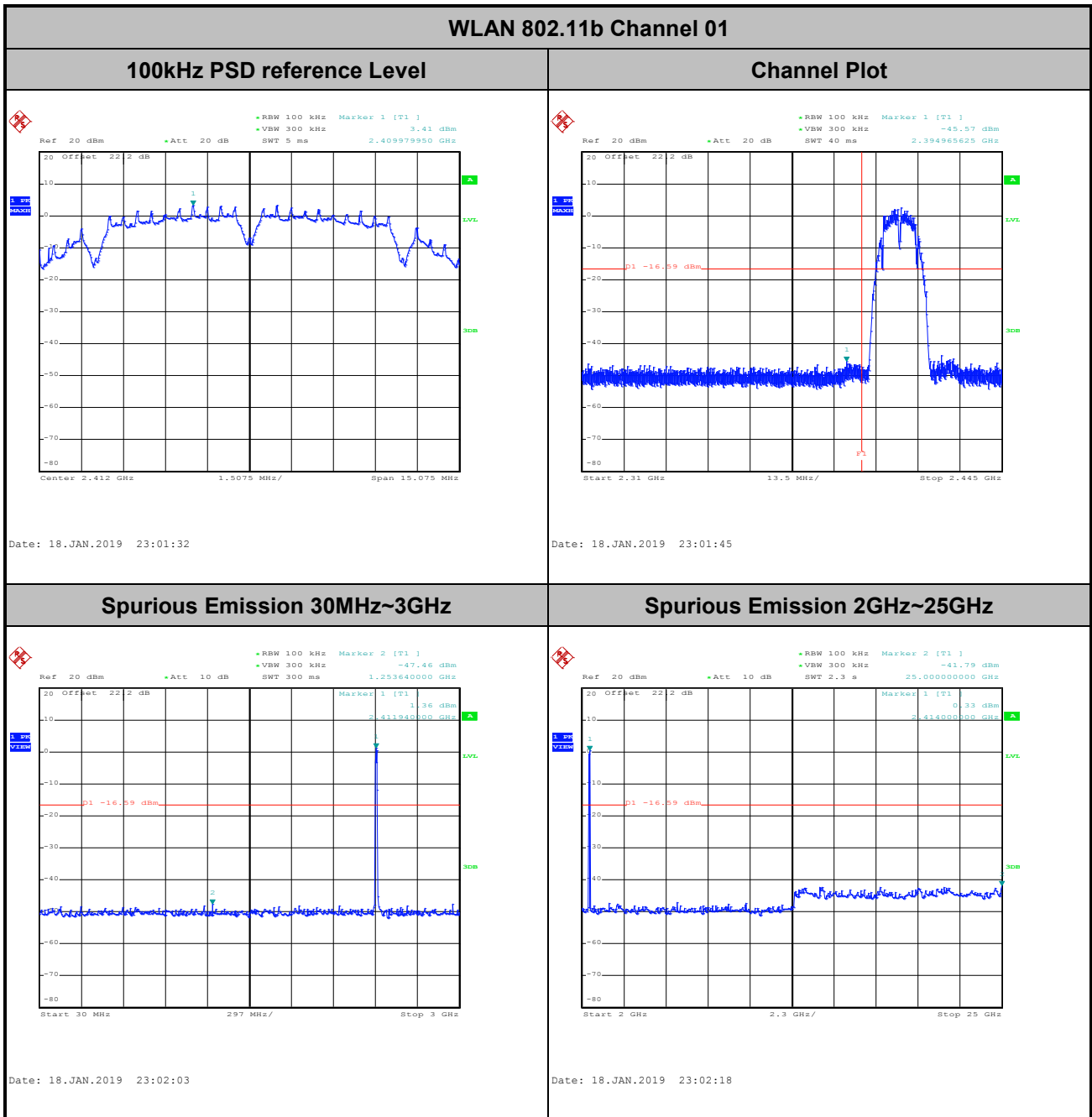



WLAN 802.11b Channel 06

100kHz PSD reference Level

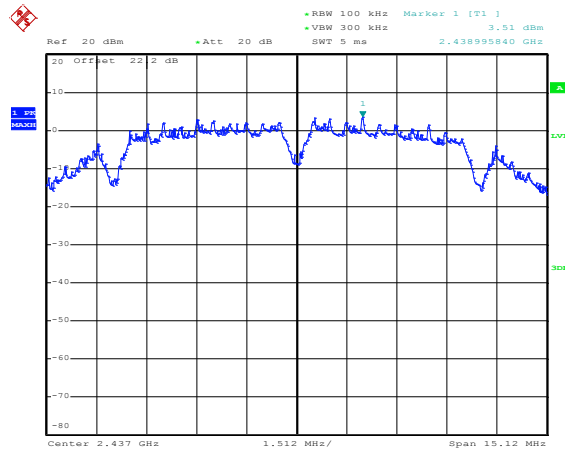

Date: 18.JAN.2019 23:11:38

Spurious Emission 30MHz~3GHz

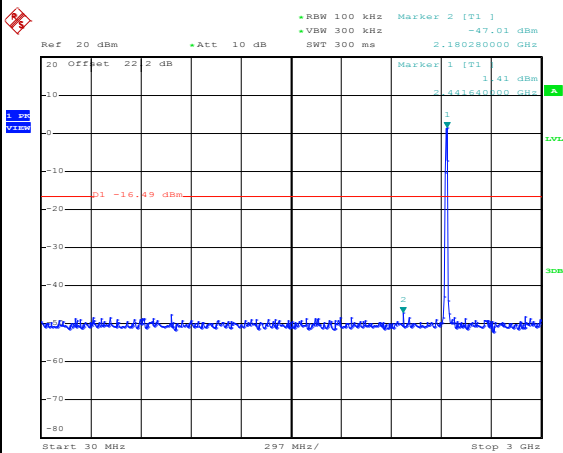

Date: 18.JAN.2019 23:11:58

Spurious Emission 2GHz~25GHz

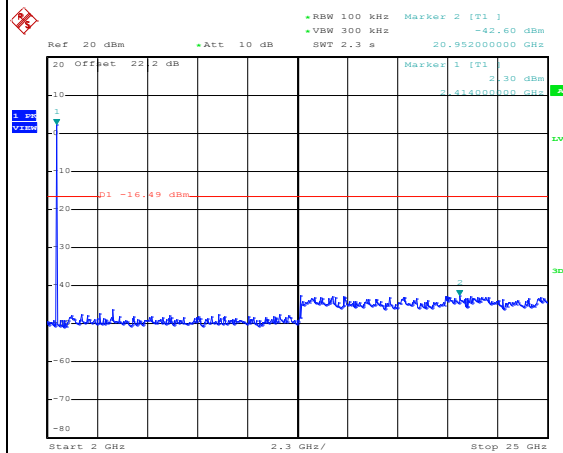

Date: 18.JAN.2019 23:12:14



WLAN 802.11b Channel 11

100kHz PSD reference Level

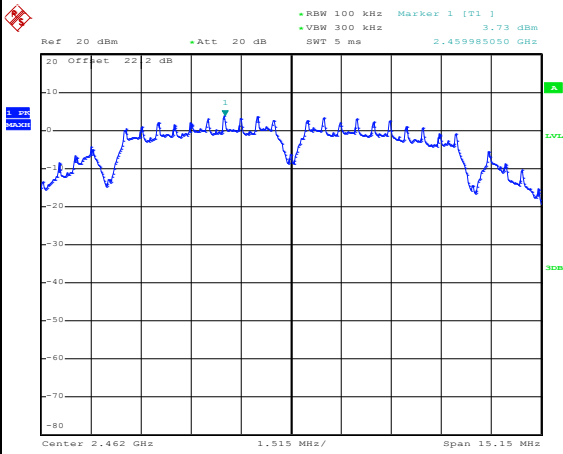

Date: 18.JAN.2019 23:22:20

Channel Plot

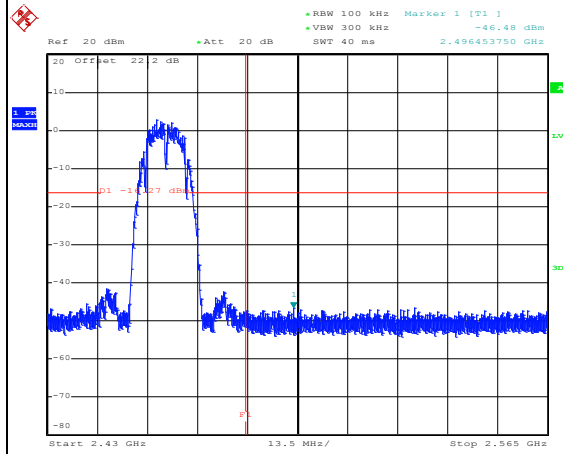

Date: 18.JAN.2019 23:24:05

Spurious Emission 30MHz~3GHz

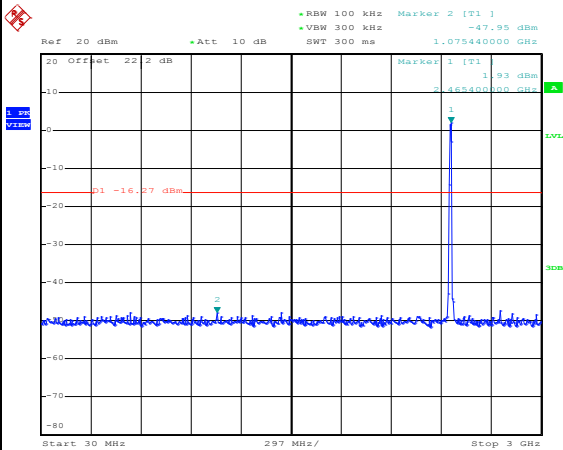

Date: 18.JAN.2019 23:24:49

Spurious Emission 2GHz~25GHz

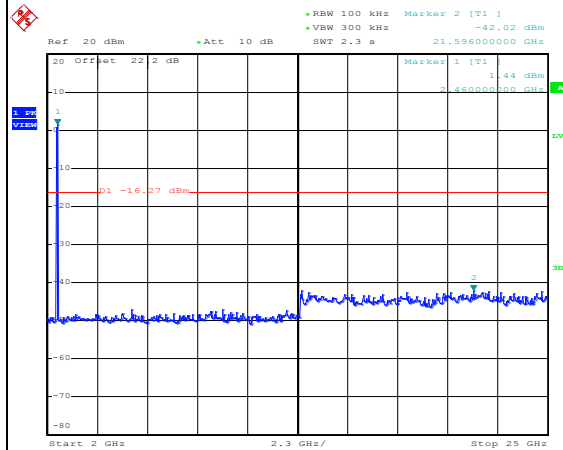

Date: 18.JAN.2019 23:25:05



WLAN 802.11g Channel 01

100kHz PSD reference Level

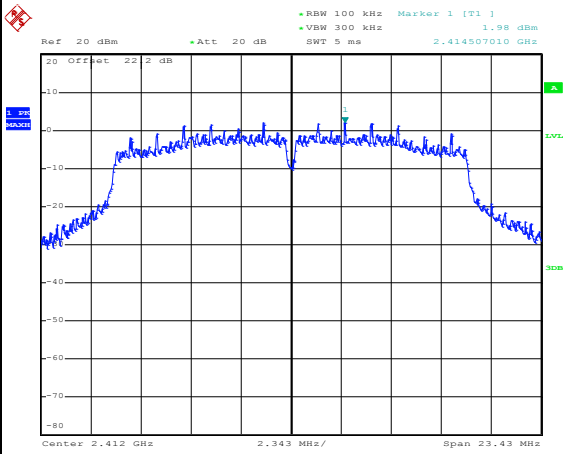

Date: 21.JAN.2019 09:19:47

Channel Plot

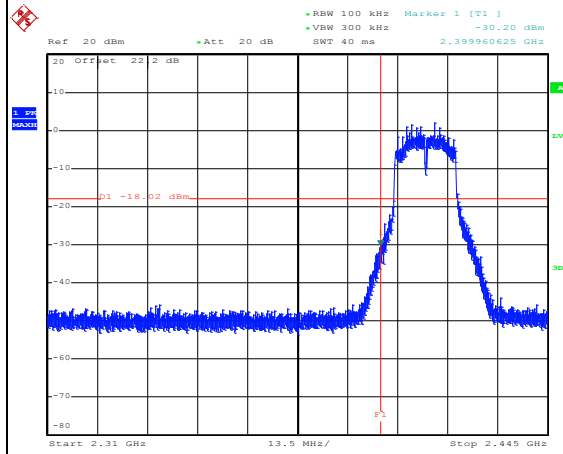

Date: 21.JAN.2019 09:20:03

Spurious Emission 30MHz~3GHz

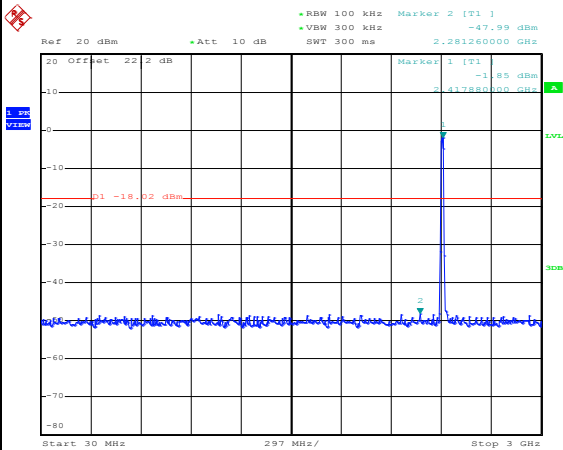

Date: 21.JAN.2019 09:21:31

Spurious Emission 2GHz~25GHz

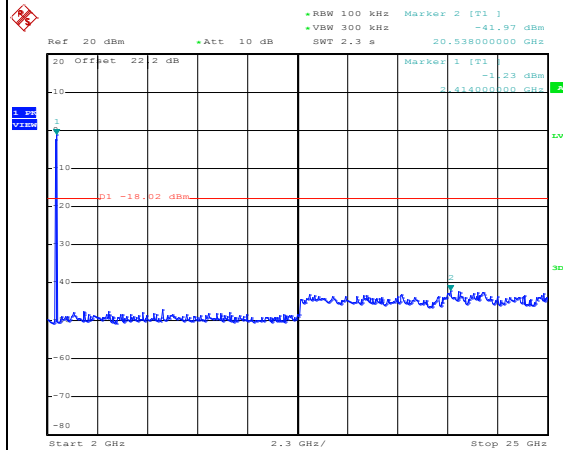

Date: 21.JAN.2019 09:21:51



WLAN 802.11g Channel 06

100kHz PSD reference Level

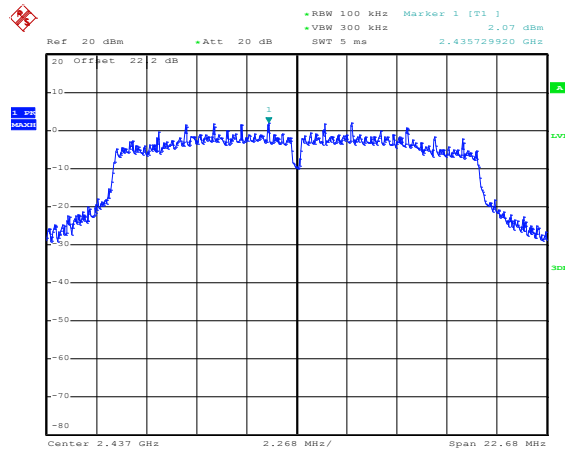

Date: 21.JAN.2019 09:32:20

Spurious Emission 30MHz~3GHz

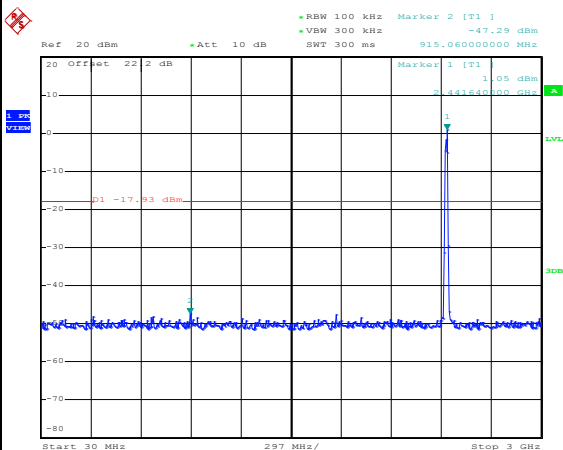

Date: 21.JAN.2019 09:32:37

Spurious Emission 2GHz~25GHz

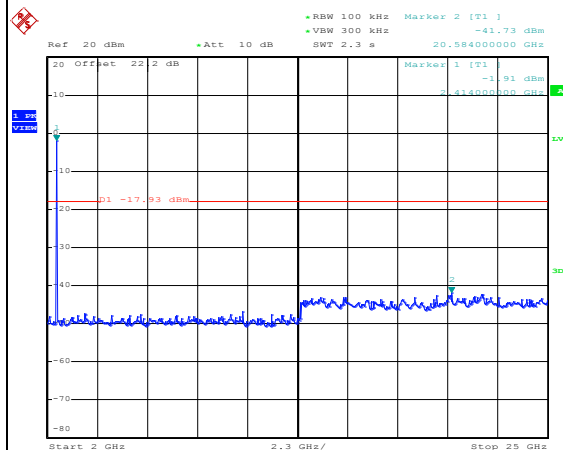

Date: 21.JAN.2019 09:34:16



WLAN 802.11g Channel 11

100kHz PSD reference Level

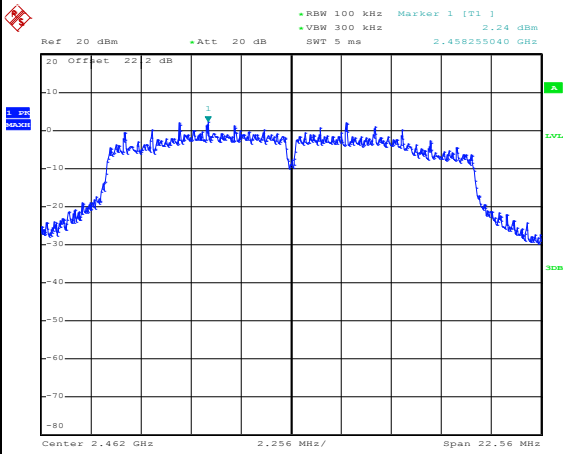

Date: 21.JAN.2019 09:41:06

Channel Plot

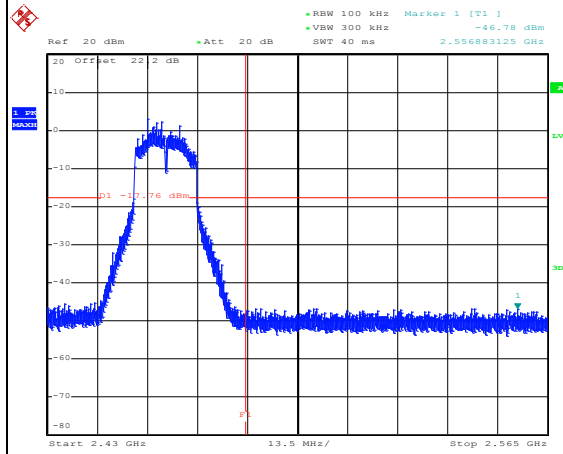

Date: 21.JAN.2019 09:41:38

Spurious Emission 30MHz~3GHz

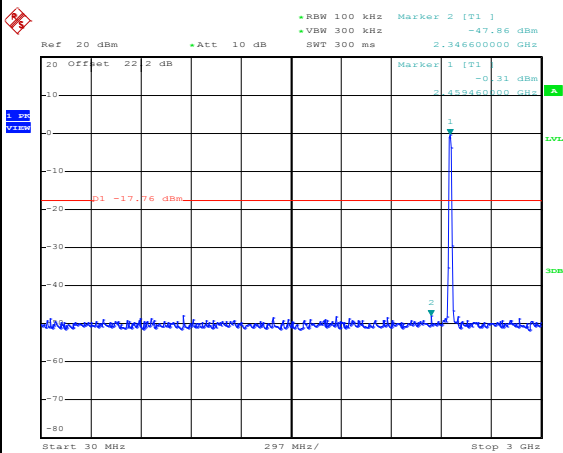

Date: 21.JAN.2019 09:43:10

Spurious Emission 2GHz~25GHz

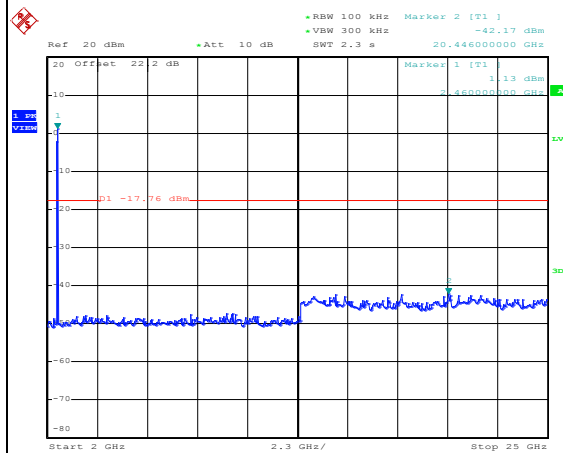

Date: 21.JAN.2019 09:46:55



WLAN 802.11n HT20 Channel 01

100kHz PSD reference Level

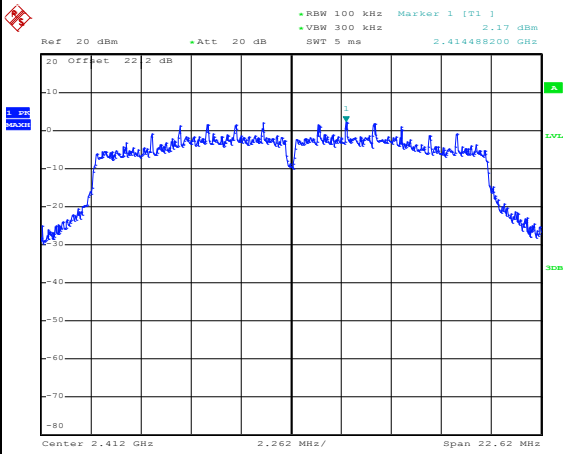

Date: 21.JAN.2019 09:55:44

Channel Plot

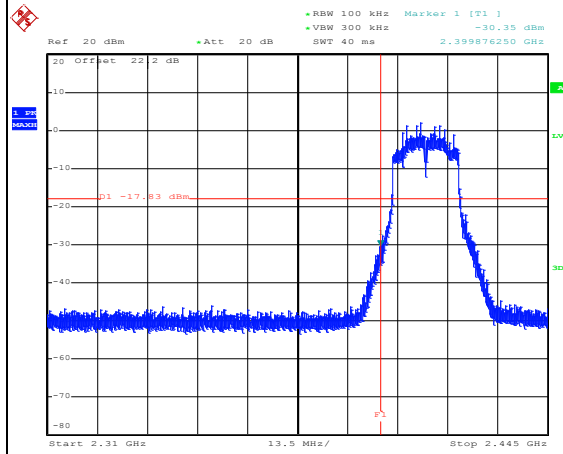

Date: 21.JAN.2019 09:56:13

Spurious Emission 30MHz~3GHz

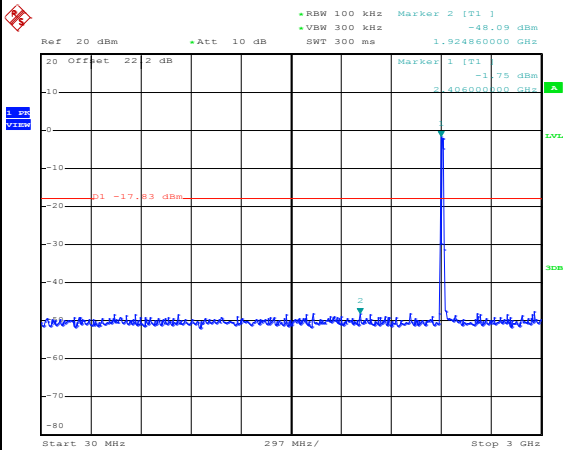

Date: 21.JAN.2019 09:56:37

Spurious Emission 2GHz~25GHz

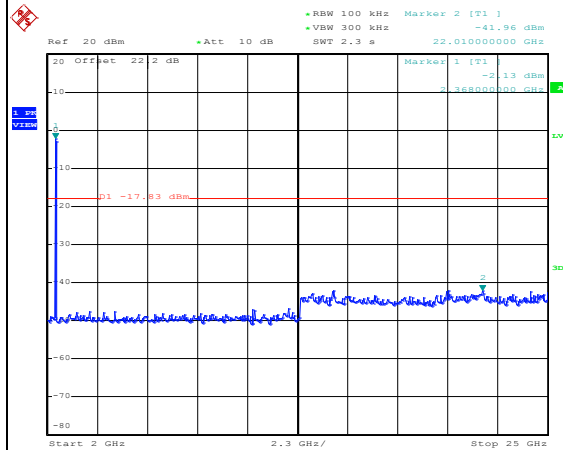

Date: 21.JAN.2019 09:56:54



WLAN 802.11n HT20 Channel 06

100kHz PSD reference Level

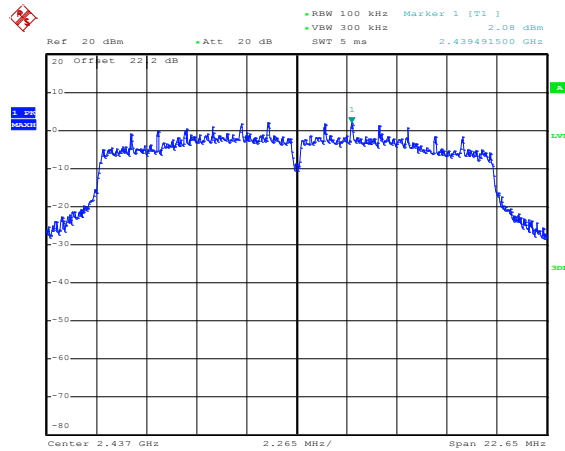

Date: 21.JAN.2019 10:05:19

Spurious Emission 30MHz~3GHz

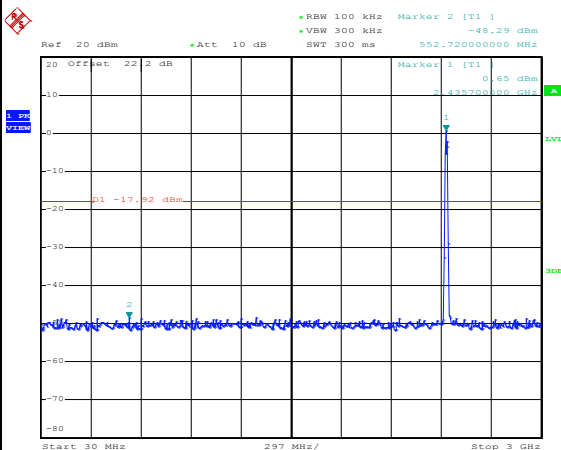

Date: 21.JAN.2019 10:06:41

Spurious Emission 2GHz~25GHz

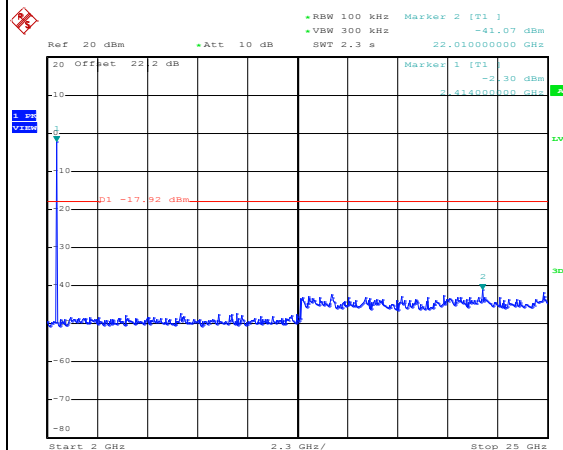

Date: 21.JAN.2019 10:07:06

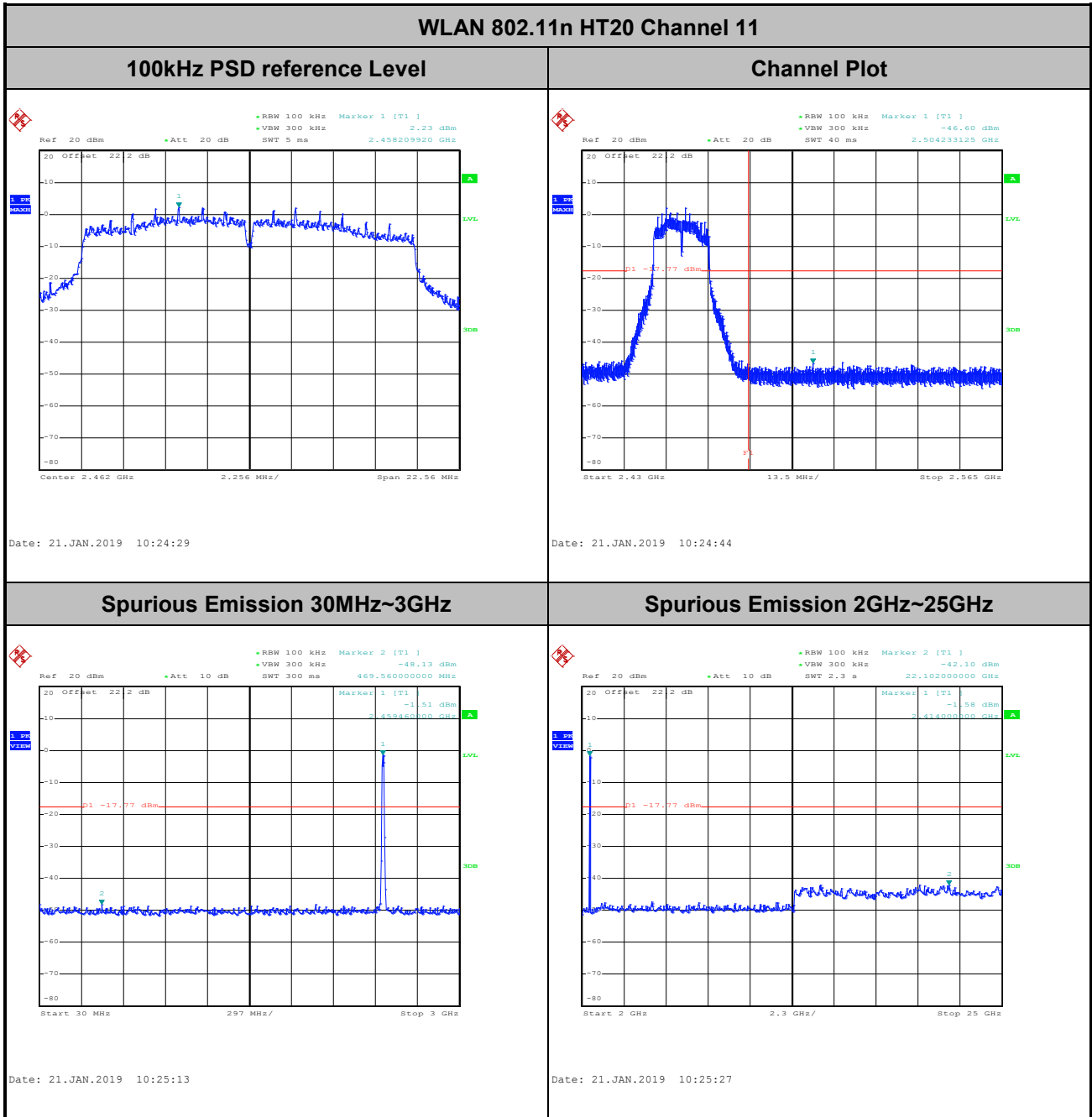

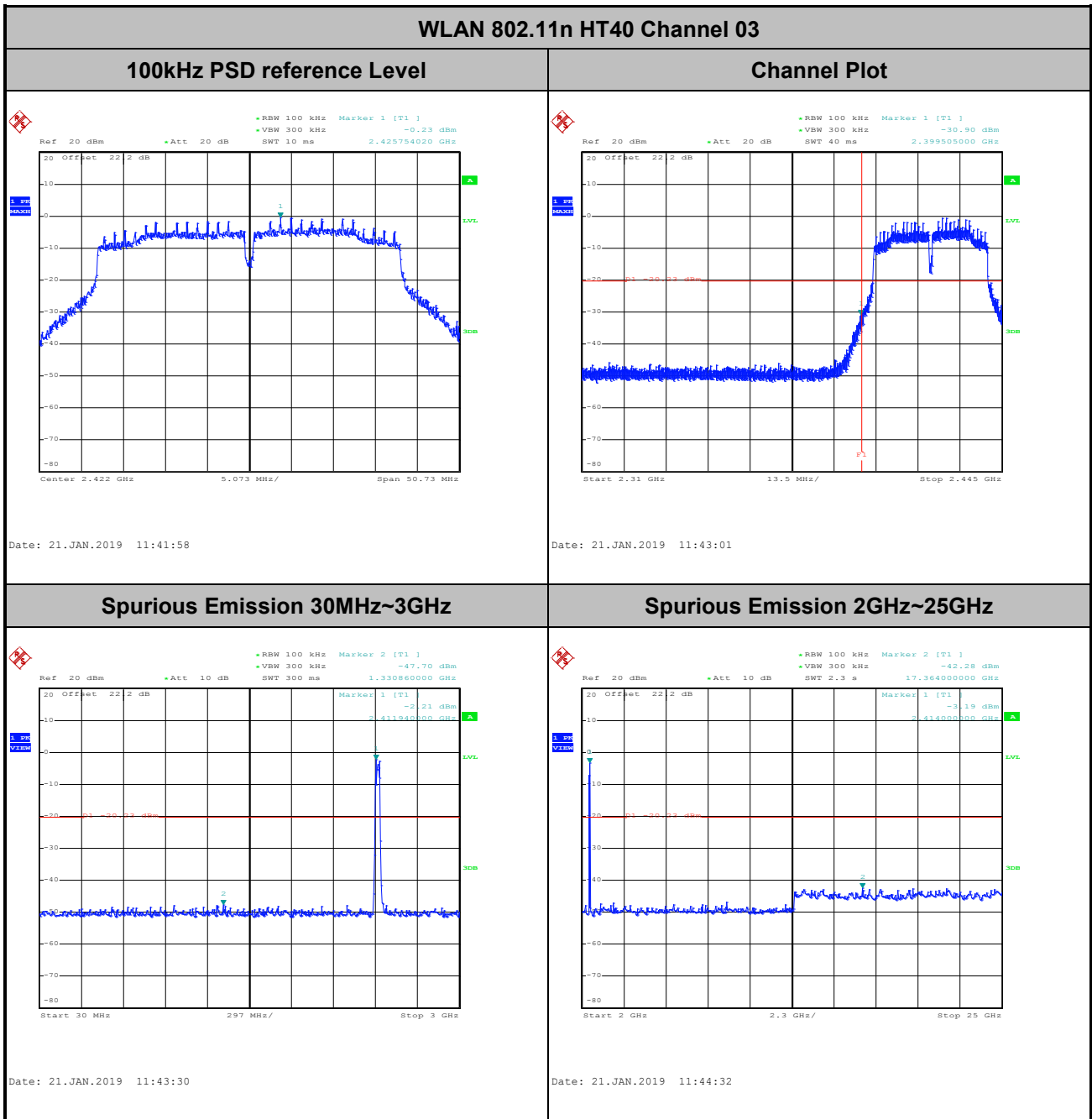



WLAN 802.11n HT40 Channel 06

100kHz PSD reference Level

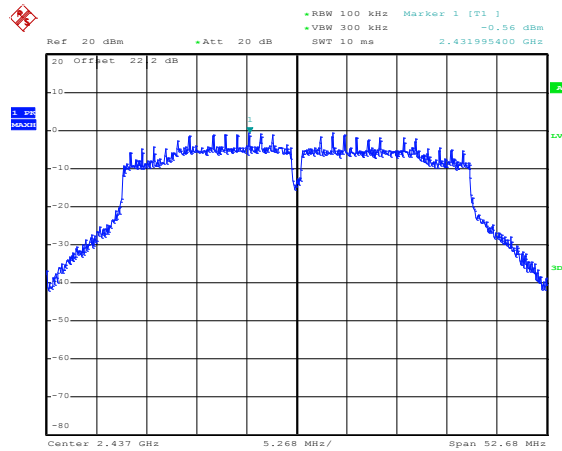

Date: 21.JAN.2019 11:56:12

Spurious Emission 30MHz~3GHz

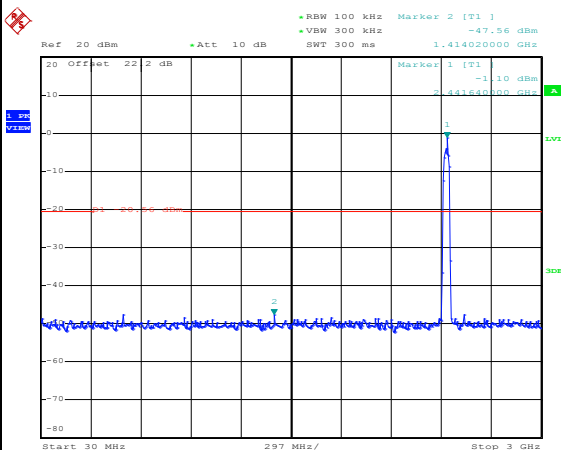

Date: 21.JAN.2019 11:58:30

Spurious Emission 2GHz~25GHz

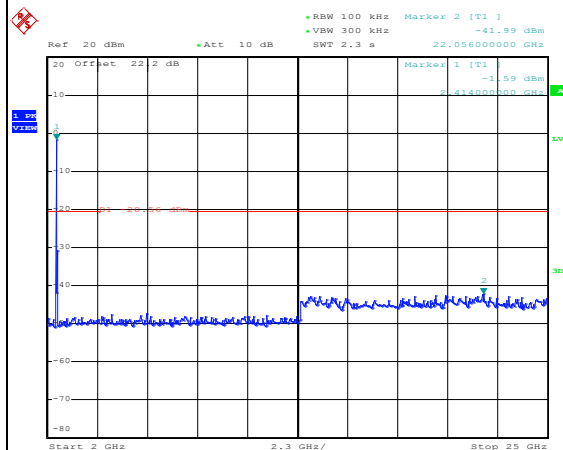

Date: 21.JAN.2019 11:58:47



WLAN 802.11n HT40 Channel 09

100kHz PSD reference Level

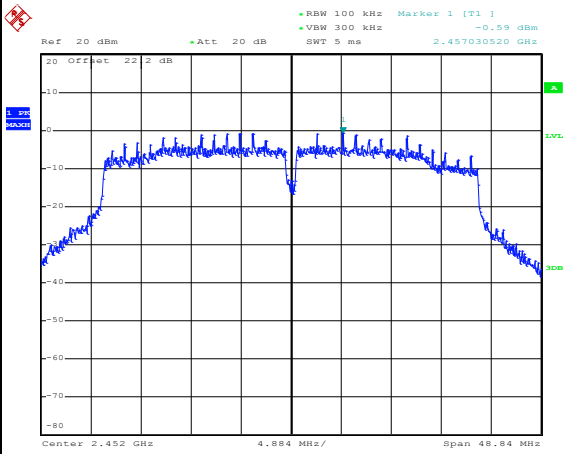

Date: 21.JAN.2019 13:46:13

Channel Plot

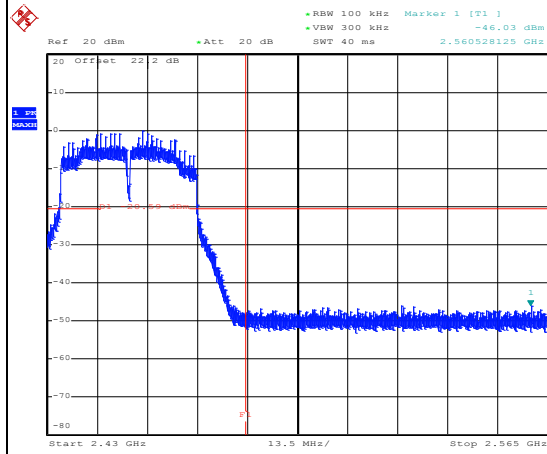

Date: 21.JAN.2019 13:46:32

Spurious Emission 30MHz~3GHz

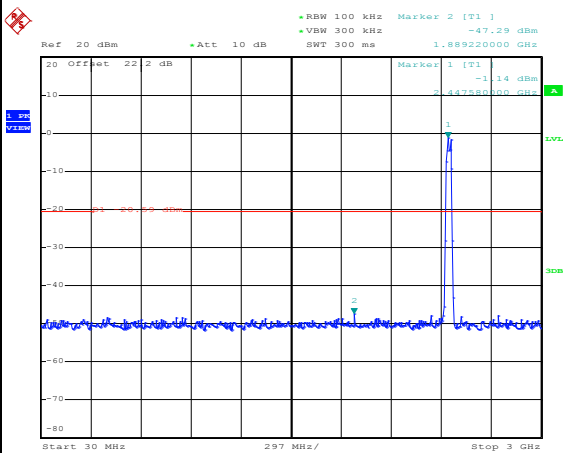

Date: 21.JAN.2019 13:46:50

Spurious Emission 2GHz~25GHz

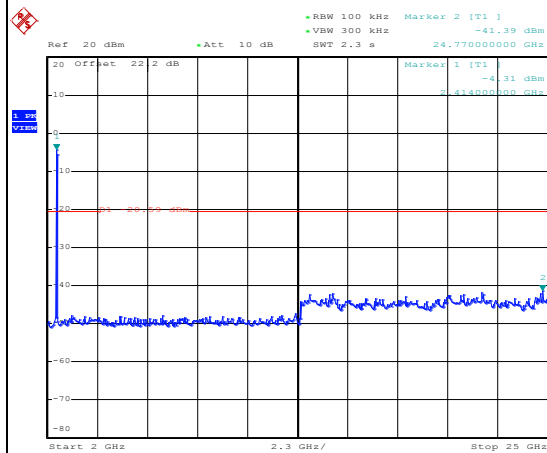

Date: 21.JAN.2019 13:47:05



3.5 Radiated Band Edges and Spurious Emission Measurement

3.5.1 Limit of Radiated band edge and Spurious Emission Measurement

In any 100 kHz bandwidth outside the intentional radiator frequency band, all harmonics/spurious must be at least 20 dB below the highest emission level within the authorized band. If the output power of this device was measured by spectrum analyzer, the attenuation under this paragraph shall be 30 dB instead of 20 dB. In addition, radiated emissions which fall in the restricted bands must also comply with the limits as below.

Frequency (MHz)	Field Strength (microvolts/meter)	Measurement Distance (meters)
0.009 – 0.490	2400/F(kHz)	300
0.490 – 1.705	24000/F(kHz)	30
1.705 – 30.0	30	30
30 – 88	100	3
88 – 216	150	3
216 - 960	200	3
Above 960	500	3

3.5.2 Measuring Instruments

See list of measuring equipment of this test report.



3.5.3 Test Procedures

1. The testing follows the ANSI C63.10 Section 11.12.1 Radiated emission measurements.
2. The EUT was arranged to its worst case and then tune the antenna tower (from 1 m to 4 m) and turntable (from 0 degree to 360 degrees) to find the maximum reading. A pre-amp and a high pass filter are used for the test in order to get better signal level.
3. The EUT was placed on a turntable with 0.8 meter for frequency below 1GHz and 1.5 meter for frequency above 1GHz respectively above ground.
4. The EUT was set 3 meters from the interference receiving antenna, which was mounted on the top of a variable height antenna tower.
5. Corrected Reading: Antenna Factor + Cable Loss + Read Level - Preamp Factor = Level
6. For testing below 1GHz, if the emission level of the EUT in peak mode was 3 dB lower than the limit specified, then peak values of EUT will be reported, otherwise, the emissions will be repeated one by one using the CISPR quasi-peak method and reported.
7. For testing above 1GHz, the emission level of the EUT in peak mode was 20dB lower than average limit (that means the emission level in average mode also complies with the limit in average mode), then peak values of EUT will be reported, otherwise, the emissions will be measured in average mode again and reported.
8. Use the following spectrum analyzer settings:
 - (1) Span shall wide enough to fully capture the emission being measured;
 - (2) Set RBW=100 kHz for $f < 1$ GHz; VBW \geq RBW; Sweep = auto; Detector function = peak; Trace = max hold;
 - (3) Set RBW = 1 MHz, VBW= 3MHz for $f \geq 1$ GHz for peak measurement.
For average measurement:
 - VBW = 10 Hz, when duty cycle is no less than 98 percent.
 - VBW $\geq 1/T$, when duty cycle is less than 98 percent where T is the minimum transmission duration over which the transmitter is on and is transmitting at its maximum power control level for the tested mode of operation.

3.5.4 Test Setup

For radiated emissions below 30MHz

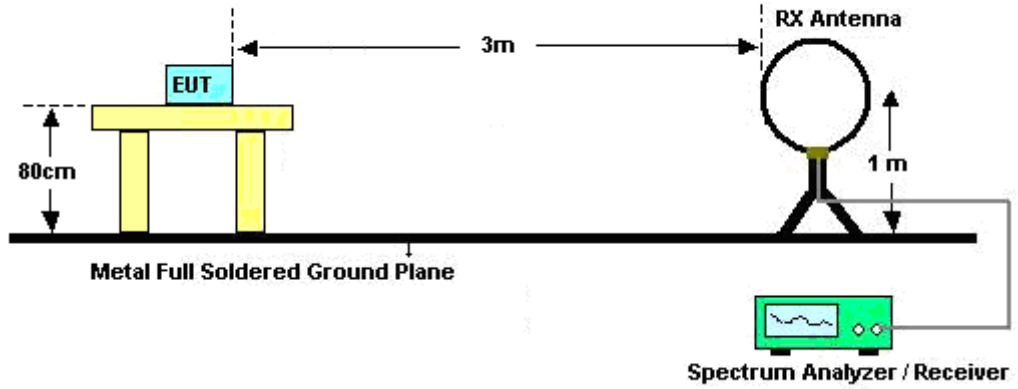

For radiated emissions from 30MHz to 1GHz

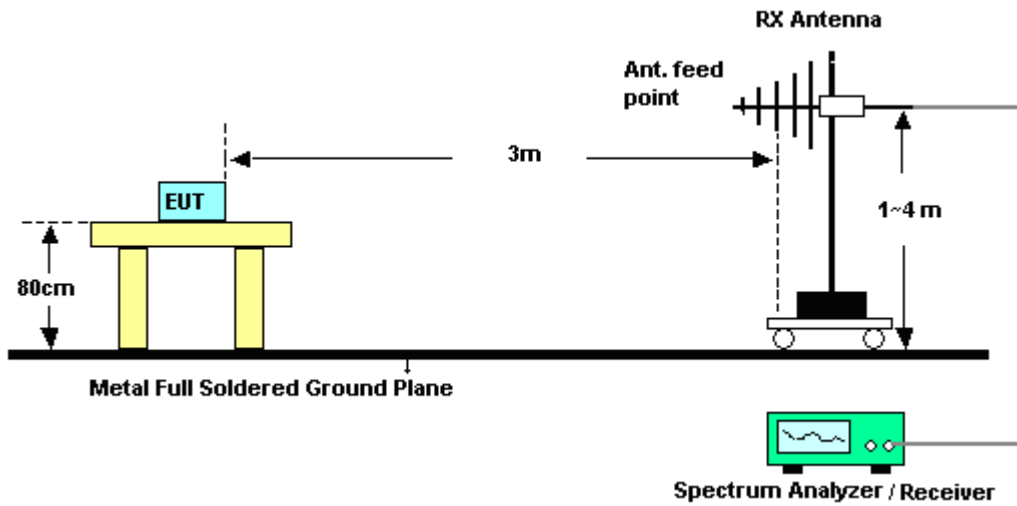

For radiated emissions above 1GHz

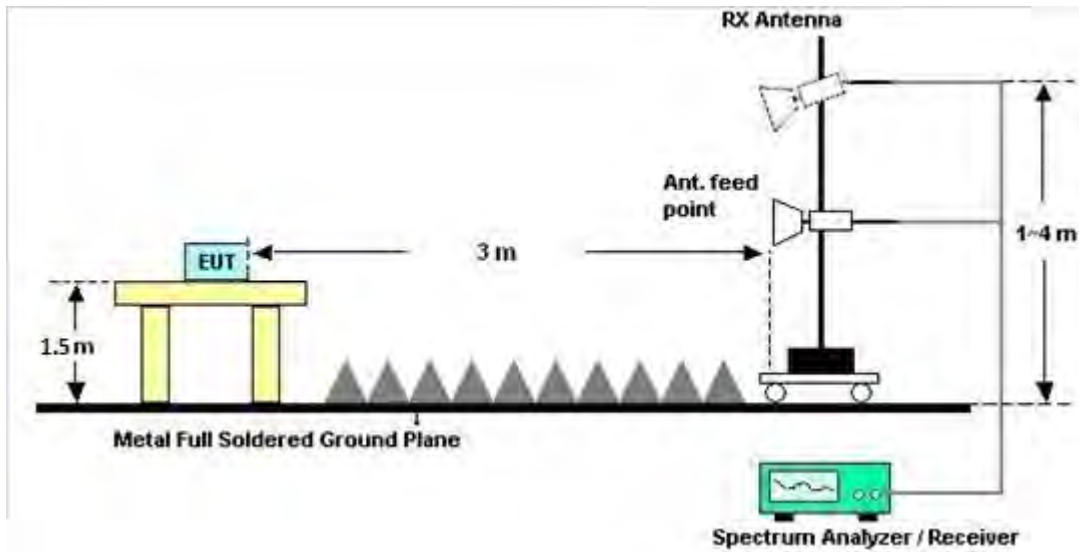

3.5.5 Test Results of Radiated Spurious Emissions (9kHz ~ 30MHz)

The low frequency, which started from 9 kHz to 30MHz, was pre-scanned and the result which was 20dB lower than the limit line was not reported.

There is a comparison data of both open-field test site and alternative test site - semi-Anechoic chamber according to 414788 D01 Radiated Test Site v01r01, and the result came out very similar.

3.5.6 Test Result of Radiated Spurious at Band Edges

Please refer to Appendix B and C.

3.5.7 Duty Cycle

Please refer to Appendix D.

3.5.8 Test Result of Radiated Spurious Emission (30MHz ~ 10th Harmonic)

Please refer to Appendix B and C.

3.6 AC Conducted Emission Measurement

3.6.1 Limit of AC Conducted Emission

For equipment that is designed to be connected to the public utility (AC) power line, the radio frequency voltage that is conducted back onto the AC power line on any frequency or frequencies within the band 150 kHz to 30 MHz shall not exceed the limits in the following table.

Frequency of Emission (MHz)	Conducted Limit (dB μ V)	
	Quasi-Peak	Average
0.15-0.5	66 to 56*	56 to 46*
0.5-5	56	46
5-30	60	50

*Decreases with the logarithm of the frequency.

3.6.2 Measuring Instruments

See list of measuring equipment of this test report.

3.6.3 Test Procedures

1. The EUT was placed 0.4 meter from the conducting wall of the shielding room, and it was kept at least 80 centimeters from any other grounded conducting surface.
2. Connect EUT to the power mains through a line impedance stabilization network (LISN).
3. All the support units are connecting to the other LISN.
4. The LISN provides 50 ohm coupling impedance for the measuring instrument.
5. The FCC states that a 50 ohm, 50 microhenry LISN should be used.
6. Both sides of AC line were checked for maximum conducted interference.
7. The frequency range from 150 kHz to 30 MHz was searched.
8. Set the test-receiver system to Peak Detect Function and specified bandwidth (IF bandwidth = 9kHz) with Maximum Hold Mode.

3.6.4 Test Setup

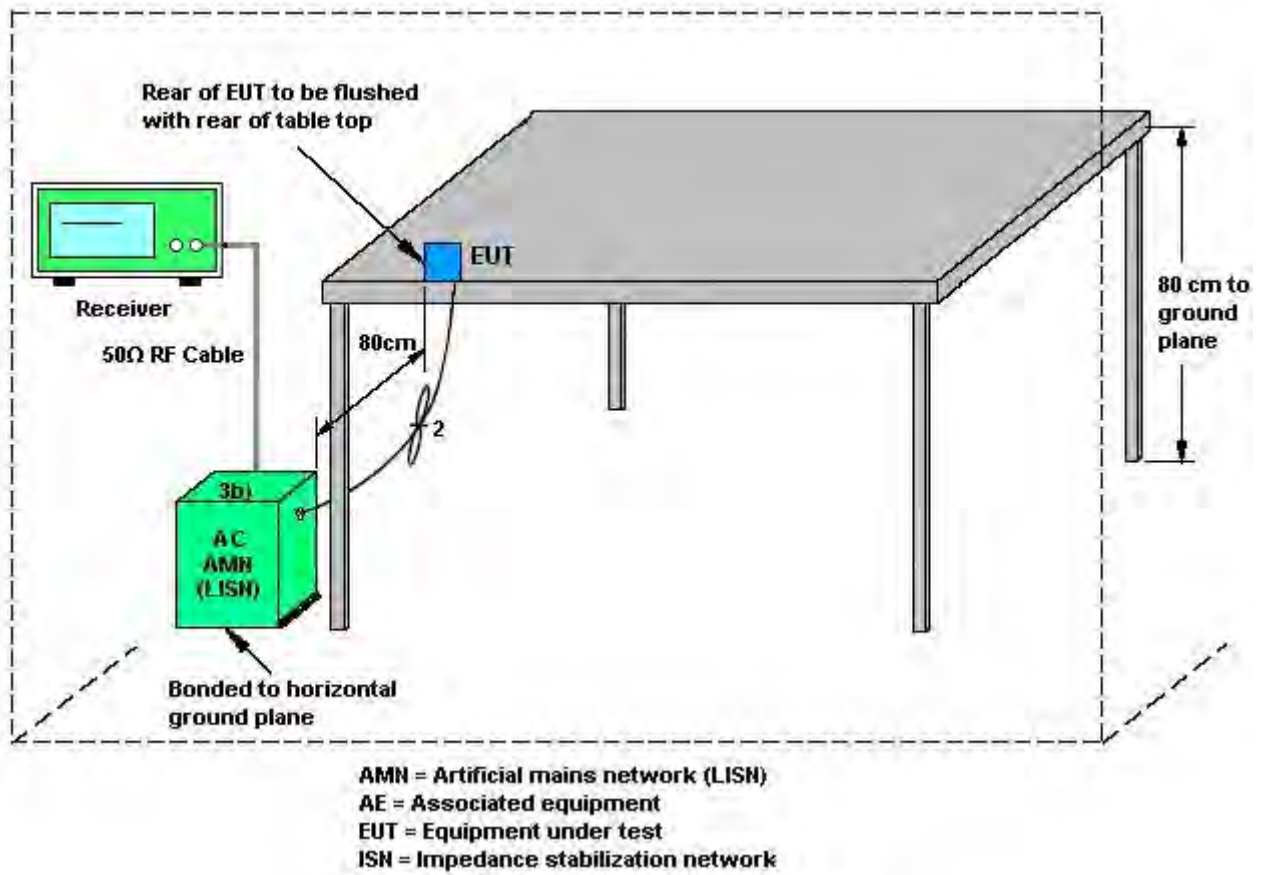

3.6.5 Test Result of AC Conducted Emission

Please refer to Appendix A.



3.7 Antenna Requirements

3.7.1 Standard Applicable

If directional gain of transmitting Antennas is greater than 6dBi, the power shall be reduced by the same level in dB comparing to gain minus 6dBi. The use of a permanently attached Antenna or of an Antenna that uses a unique coupling to the intentional radiator shall be considered sufficient to comply with the rule.

3.7.2 Antenna Anti-Replacement Construction

An embedded-in antenna design is used.

3.7.3 Antenna Gain

<CDD Modes >

FCC KDB 662911 D01 Multiple Transmitter Output v02r01

For CDD transmissions, directional gain is calculated as

Directional gain = G_{ANT} + Array Gain, where Array Gain is as follows.

For power spectral density (PSD) measurements on all devices,

Array Gain = $10 \log(N_{ANT}/N_{SS}=1)$ dB.

For power measurements on IEEE 802.11 devices,

Array Gain = 0 dB (i.e., no array gain) for $N_{ANT} \leq 4$.

Directional gain may be calculated by using the formulas applicable to equal gain antennas with G_{ANT} set equal to the gain of the antenna having the highest gain;

The EUT supports CDD mode.

For power, the directional gain G_{ANT} is set equal to the antenna having the highest gain, i.e., F)2)f)i).

For PSD, the directional gain calculation is following F)2)f)ii) of KDB 662911 D01 v02r01.

The power and PSD limit should be modified if the directional gain of EUT is over 6 dBi,

The directional gain "DG" is calculated as following table.

<CDD Modes>						
			DG	DG	Power	PSD
	Ant. 1	Ant. 2	for	for	Limit	Limit
	(dBi)	(dBi)	Power	PSD	Reduction	Reduction
			(dBi)	(dBi)	(dB)	(dB)
2.4 GHz	2.00	1.00	2.00	4.52	0.00	0.00

$Power\ Limit\ Reduction = DG(Power) - 6dBi, (min = 0)$

$PSD\ Limit\ Reduction = DG(PSD) - 6dBi, (min = 0)$



4 List of Measuring Equipment

Instrument	Manufacturer	Model No.	Serial No.	Characteristics	Calibration Date	Test Date	Due Date	Remark
Power Meter	Anritsu	ML2495A	1132003	N/A	Aug. 16, 2018	Jan. 10, 2019~ Jan. 23, 2019	Aug. 15, 2019	Conducted (TH05-HY)
Power Sensor	Anritsu	MA2411B	1126017	300MHz~40GHz	Aug. 16, 2018	Jan. 10, 2019~ Jan. 23, 2019	Aug. 15, 2019	Conducted (TH05-HY)
Signal Analyzer	Rohde & Schwarz	FSP40	100055	9kHz~40GHz	Jun. 14, 2018	Jan. 10, 2019~ Jan. 23, 2019	Jun. 13, 2019	Conducted (TH05-HY)
Spectrum Analyzer	Rohde & Schwarz	FSV 30	100895	9kHz~30GHz	Apr. 20, 2018	Jan. 10, 2019~ Jan. 23, 2019	Apr. 19, 2019	Conducted (TH05-HY)
Programmable Power Supply	GW Instek	PSS-2005	EL890094	1V~20V 0.5A~5A	Oct. 02, 2018	Jan. 10, 2019~ Jan. 23, 2019	Oct. 01, 2019	Conducted (TH05-HY)
Switch Box & RF Cable	Burgeon	ETF-058	EC1300484	N/A	Mar. 01, 2018	Jan. 10, 2019~ Jan. 23, 2019	Feb. 28, 2019	Conducted (TH05-HY)
AC Power Source	ChainTek	APC-1000W	N/A	N/A	N/A	Jan. 11, 2019	N/A	Conduction (CO05-HY)
EMI Test Receiver	Rohde & Schwarz	ESR3	102388	9KHz~3.6GHz	Nov. 12, 2018	Jan. 11, 2019	Nov. 11, 2019	Conduction (CO05-HY)
LISN	Rohde & Schwarz	ENV216	100080	9kHz~30MHz	Nov. 14, 2018	Jan. 11, 2019	Nov. 13, 2019	Conduction (CO05-HY)
Software	Rohde & Schwarz	EMC32 V10.30	N/A	N/A	N/A	Jan. 11, 2019	N/A	Conduction (CO05-HY)
LF Cable	HUBER + SUHNER	RG-214/U	LF01	N/A	Dec. 31, 2018	Jan. 11, 2019	Dec. 30, 2019	Conduction (CO05-HY)
Pulse Limiter	Rohde & Schwarz	ESH3-Z2	100851	N/A	Dec. 31, 2018	Jan. 11, 2019	Dec. 30, 2019	Conduction (CO05-HY)
Loop Antenna	Rohde & Schwarz	HFH2-Z2	100488	9 kHz~30 MHz	Jan. 07, 2019	Jan. 16, 2019~ Jan. 21, 2019	Jan. 06, 2020	Radiation (03CH16-HY)
Bilog Antenna	TESEQ	CBL6111D&00 802N1D01N-06	47020&06	30MHz to 1GHz	Oct. 13, 2018	Jan. 16, 2019~ Jan. 21, 2019	Oct. 12, 2019	Radiation (03CH16-HY)
Horn Antenna	SCHWARZBECK	BBHA 9120 D	9120D-1522	1G~18GHz	Sep. 07, 2018	Jan. 16, 2019~ Jan. 21, 2019	Sep. 06, 2019	Radiation (03CH16-HY)
SHF-EHF Horn Antenna	SCHWARZBECK	BBHA 9170	BBHA9170576	18GHz ~ 40GHz	May 08, 2018	Jan. 16, 2019~ Jan. 21, 2019	May 07, 2019	Radiation (03CH16-HY)
EMI Test Receiver	Keysight	N9038A (MXE)	MY57290111	3Hz~26.5GHz	Nov. 29, 2018	Jan. 16, 2019~ Jan. 21, 2019	Nov. 28, 2019	Radiation (03CH16-HY)
Spectrum Analyzer	Agilent	N9010A	MY53470118	10Hz~44GHz	Apr. 17, 2018	Jan. 16, 2019~ Jan. 21, 2019	Apr. 16, 2019	Radiation (03CH16-HY)
Amplifier	SONOMA	310N	371607	9kHz~1000MHz	Oct. 02, 2018	Jan. 16, 2019~ Jan. 21, 2019	Oct. 01, 2019	Radiation (03CH16-HY)
Preamplifier	Jet-Power	JPA0118-55-30 3	171000180005 4001	1GHz~18GHz	Apr. 16, 2018	Jan. 16, 2019~ Jan. 21, 2019	Apr. 15, 2019	Radiation (03CH16-HY)
Preamplifier	Keysight	83017A	MY53270147	1GHz~26.5GHz	Feb. 02, 2018	Jan. 16, 2019~ Jan. 21, 2019	Feb. 01, 2019	Radiation (03CH16-HY)
Amplifier	MITEQ	TTA1840-35-H G	1871923	18GHz~40GHz, VSWR : 2.5:1 max	Jul. 16, 2018	Jan. 16, 2019~ Jan. 21, 2019	Jul. 15, 2019	Radiation (03CH16-HY)
RF Cable	HUBER + SUHNER	SUCOFLEX 126E	0058/126E	30M-18G	Mar. 14, 2018	Jan. 16, 2019~ Jan. 21, 2019	Mar. 13, 2019	Radiation (03CH16-HY)
RF Cable	HUBER + SUHNER	SUCOFLEX 104	MY15539/4	30M-18G	Mar. 14, 2018	Jan. 16, 2019~ Jan. 21, 2019	Mar. 13, 2019	Radiation (03CH16-HY)
RF Cable	HUBER + SUHNER	SUCOFLEX 104	MY9837/4PE	30M~18GHz	Mar. 14, 2018	Jan. 16, 2019~ Jan. 21, 2019	Mar. 13, 2019	Radiation (03CH16-HY)
RF Cable	HUBER + SUHNER	SUCOFLEX 104	MY36979/4	30M~18GHz	Mar. 14, 2018	Jan. 16, 2019~ Jan. 21, 2019	Mar. 13, 2019	Radiation (03CH16-HY)
Software	Audix	E3 6.2009-8-24	RK-001136	N/A	N/A	Jan. 16, 2019~ Jan. 21, 2019	N/A	Radiation (03CH16-HY)



5 Uncertainty of Evaluation

Uncertainty of Conducted Emission Measurement (150kHz ~ 30MHz)

Measuring Uncertainty for a Level of Confidence of 95% ($U = 2Uc(y)$)	2.2
---	-----

Uncertainty of Radiated Emission Measurement (30 MHz ~ 1000 MHz)

Measuring Uncertainty for a Level of Confidence of 95% ($U = 2Uc(y)$)	4.9
---	-----

Uncertainty of Radiated Emission Measurement (1000 MHz ~ 18000 MHz)

Measuring Uncertainty for a Level of Confidence of 95% ($U = 2Uc(y)$)	5.8
---	-----

Uncertainty of Radiated Emission Measurement (18000 MHz ~ 40000 MHz)

Measuring Uncertainty for a Level of Confidence of 95% ($U = 2Uc(y)$)	3.9
---	-----



Appendix A. AC Conducted Emission Test Results

Test Mode :	Mode 1	Temperature :	24~26°C
Test Engineer :	Jimmy Chang	Relative Humidity :	51~53%
Test Voltage :	120Vac / 60Hz	Phase :	Line

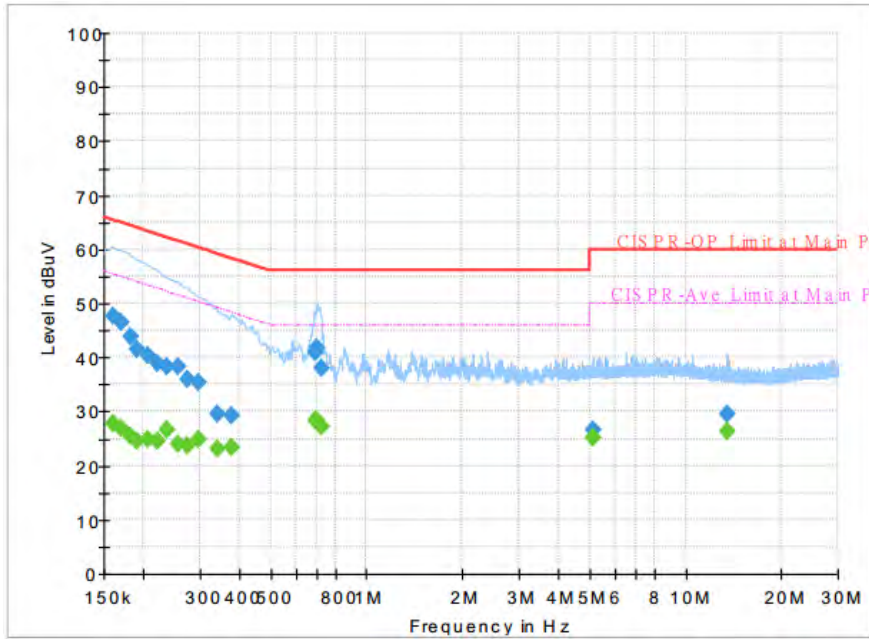

Final Result :

Frequency (MHz)	QuasiPeak (dBuV)	CAverage (dBuV)	Limit (dBuV)	Margin (dB)	Line	Filter	Corr. (dB)
0.161250	---	27.71	55.40	27.69	L1	OFF	19.5
0.161250	47.52	---	65.40	17.88	L1	OFF	19.5
0.170250	---	27.03	54.95	27.92	L1	OFF	19.5
0.170250	46.41	---	64.95	18.54	L1	OFF	19.5
0.181500	---	25.43	54.42	28.99	L1	OFF	19.5
0.181500	43.74	---	64.42	20.68	L1	OFF	19.5
0.190500	---	24.69	54.02	29.33	L1	OFF	19.5
0.190500	41.45	---	64.02	22.57	L1	OFF	19.5
0.206250	---	24.90	53.36	28.46	L1	OFF	19.5
0.206250	40.47	---	63.36	22.89	L1	OFF	19.5
0.219750	---	24.55	52.83	28.28	L1	OFF	19.5
0.219750	39.01	---	62.83	23.82	L1	OFF	19.5
0.235500	---	26.72	52.25	25.53	L1	OFF	19.5
0.235500	38.17	---	62.25	24.08	L1	OFF	19.5
0.255750	---	23.90	51.57	27.67	L1	OFF	19.5
0.255750	38.23	---	61.57	23.34	L1	OFF	19.5
0.273750	---	23.74	51.00	27.26	L1	OFF	19.5
0.273750	35.83	---	61.00	25.17	L1	OFF	19.5
0.296250	---	24.84	50.35	25.51	L1	OFF	19.5
0.296250	35.43	---	60.35	24.92	L1	OFF	19.5
0.341250	---	23.10	49.17	26.07	L1	OFF	19.5
0.341250	29.40	---	59.17	29.77	L1	OFF	19.5



Test Mode :	Mode 1	Temperature :	24~26°C
Test Engineer :	Jimmy Chang	Relative Humidity :	51~53%
Test Voltage :	120Vac / 60Hz	Phase :	Line

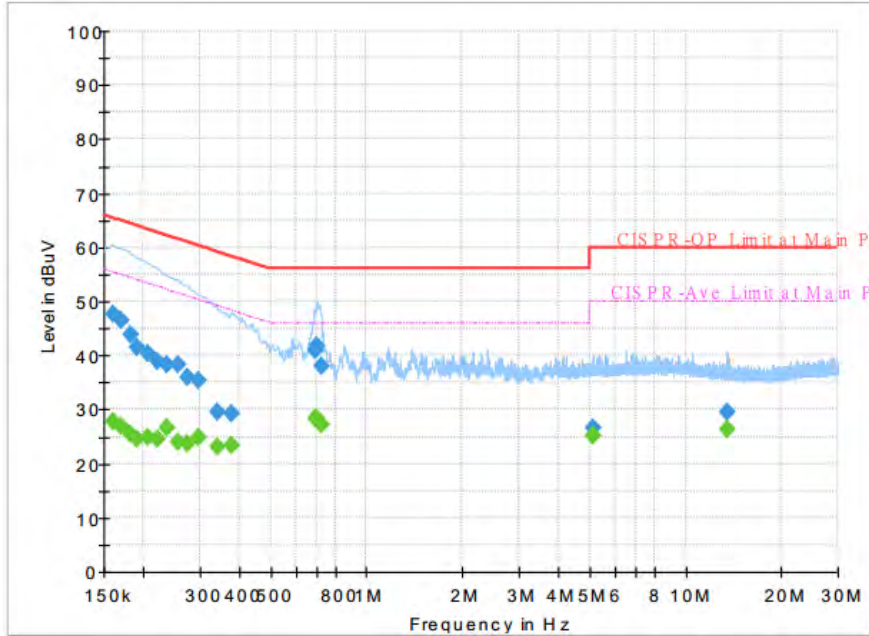

Final Result :

Frequency (MHz)	QuasiPeak (dBuV)	CAverage (dBuV)	Limit (dBuV)	Margin (dB)	Line	Filter	Corr. (dB)
0.379500	---	23.42	48.29	24.87	L1	OFF	19.5
0.379500	29.33	---	58.29	28.96	L1	OFF	19.5
0.690000	---	28.30	46.00	17.70	L1	OFF	19.6
0.690000	40.89	---	56.00	15.11	L1	OFF	19.6
0.701250	---	28.24	46.00	17.76	L1	OFF	19.6
0.701250	41.92	---	56.00	14.08	L1	OFF	19.6
0.719250	---	27.25	46.00	18.75	L1	OFF	19.6
0.719250	38.10	---	56.00	17.90	L1	OFF	19.6
5.147250	---	25.17	50.00	24.83	L1	OFF	19.7
5.147250	26.65	---	60.00	33.35	L1	OFF	19.7
13.560000	---	26.23	50.00	23.77	L1	OFF	20.0
13.560000	29.39	---	60.00	30.61	L1	OFF	20.0



Tese Mode :	Mode 1	Temperature :	24~26°C
Test Engineer :	Jimmy Chang	Relative Humidity :	51~53%
Test Voltage :	120Vac / 60Hz	Phase :	Neutral

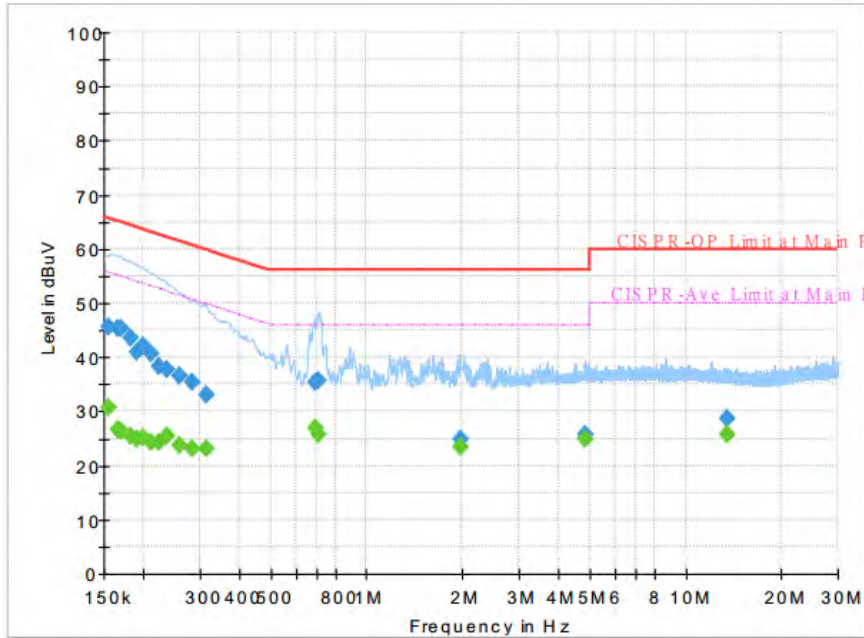

Final Result :

Frequency (MHz)	QuasiPeak (dBuV)	CAverage (dBuV)	Limit (dBuV)	Margin (dB)	Line	Filter	Corr. (dB)
0.154500	---	30.78	55.75	24.97	N	OFF	19.5
0.154500	45.49	---	65.75	20.26	N	OFF	19.5
0.165750	---	26.73	55.17	28.44	N	OFF	19.5
0.165750	45.35	---	65.17	19.82	N	OFF	19.5
0.170250	---	26.38	54.95	28.57	N	OFF	19.5
0.170250	45.30	---	64.95	19.65	N	OFF	19.5
0.181500	---	25.43	54.42	28.99	N	OFF	19.5
0.181500	43.69	---	64.42	20.73	N	OFF	19.5
0.190500	---	24.80	54.02	29.22	N	OFF	19.5
0.190500	40.83	---	64.02	23.19	N	OFF	19.5
0.199500	---	25.07	53.63	28.56	N	OFF	19.5
0.199500	42.01	---	63.63	21.62	N	OFF	19.5
0.210750	---	24.37	53.18	28.81	N	OFF	19.5
0.210750	40.73	---	63.18	22.45	N	OFF	19.5
0.224250	---	24.29	52.66	28.37	N	OFF	19.5
0.224250	38.44	---	62.66	24.22	N	OFF	19.5
0.237750	---	25.48	52.17	26.69	N	OFF	19.5
0.237750	37.83	---	62.17	24.34	N	OFF	19.5
0.258000	---	23.69	51.50	27.81	N	OFF	19.5
0.258000	36.47	---	61.50	25.03	N	OFF	19.5
0.285000	---	23.24	50.67	27.43	N	OFF	19.5
0.285000	35.24	---	60.67	25.43	N	OFF	19.5
0.314250	---	23.08	49.86	26.78	N	OFF	19.5
0.314250	33.04	---	59.86	26.82	N	OFF	19.5



Tese Mode :	Mode 1	Temperature :	24~26°C
Test Engineer :	Jimmy Chang	Relative Humidity :	51~53%
Test Voltage :	120Vac / 60Hz	Phase :	Neutral

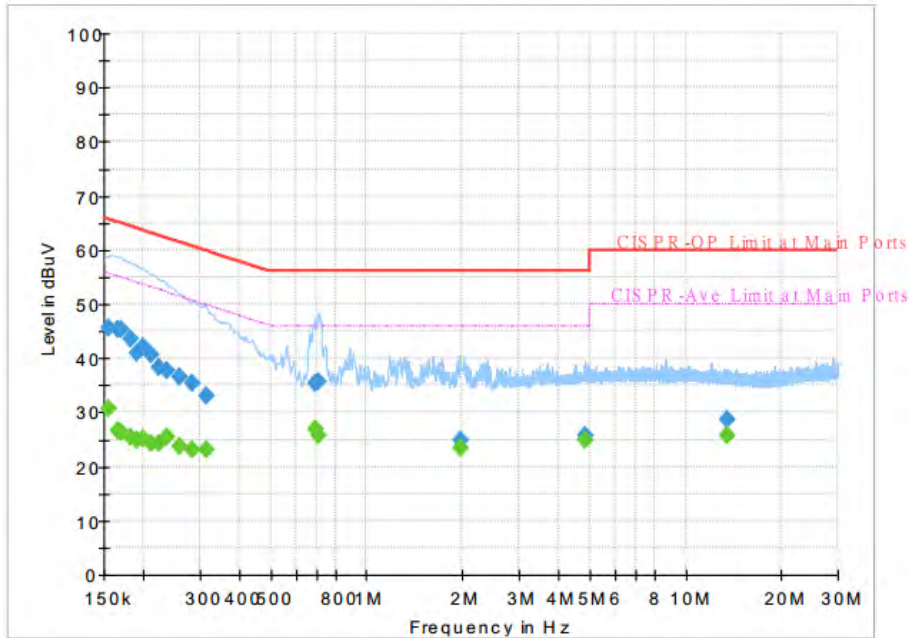

Final Result :

Frequency (MHz)	QuasiPeak (dBuV)	CAverage (dBuV)	Limit (dBuV)	Margin (dB)	Line	Filter	Corr. (dB)
0.687750	---	26.76	46.00	19.24	N	OFF	19.6
0.687750	35.32	---	56.00	20.68	N	OFF	19.6
0.705750	---	25.83	46.00	20.17	N	OFF	19.6
0.705750	35.69	---	56.00	20.31	N	OFF	19.6
1.959000	---	23.32	46.00	22.68	N	OFF	19.6
1.959000	24.90	---	56.00	31.10	N	OFF	19.6
4.839000	---	24.76	46.00	21.24	N	OFF	19.7
4.839000	25.85	---	56.00	30.15	N	OFF	19.7
13.560000	---	25.82	50.00	24.18	N	OFF	20.1
13.560000	28.56	---	60.00	31.44	N	OFF	20.1



Appendix B. Radiated Spurious Emission

Test Engineer :	Jacky Hung, CR Liao, and Andy Yang	Temperature :	23~25°C
		Relative Humidity :	55~57%

2.4GHz 2400~2483.5MHz

WIFI 802.11b (Band Edge @ 3m)

WIFI	Note	Frequency	Level	Over	Limit	Read	Antenna	Path	Preamp	Ant	Table	Peak	Pol.	
Ant.				Limit	Line	Level	Factor	Loss	Factor	Pos	Pos	Avg.		
1		(MHz)	(dBμV/m)	(dB)	(dBμV/m)	(dBμV)	(dB/m)	(dB)	(dB)	(cm)	(deg)	(P/A)	(H/V)	
802.11b CH 01 2412MHz		2390	56.61	-17.39	74	41.04	27.24	18.32	29.99	218	23	P	H	
		2390	45.17	-8.83	54	29.6	27.24	18.32	29.99	218	23	A	H	
	*	2412	111.88	-	-	96.24	27.29	18.34	29.99	218	23	P	H	
	*	2412	108.84	-	-	93.2	27.29	18.34	29.99	218	23	A	H	
													H	
														H
			2390	57.24	-16.76	74	41.67	27.24	18.32	29.99	232	326	P	V
			2390	47.92	-6.08	54	32.35	27.24	18.32	29.99	232	326	A	V
	*		2412	111.19	-	-	95.55	27.29	18.34	29.99	232	326	P	V
	*		2412	108.19	-	-	92.55	27.29	18.34	29.99	232	326	A	V
														V
														V
802.11b CH 06 2437MHz		2325.54	56.07	-17.93	74	40.78	27.08	18.22	30.01	335	4	P	H	
		2389.1	45.25	-8.75	54	29.7	27.23	18.31	29.99	335	4	A	H	
	*	2437	112.33	-	-	96.61	27.35	18.35	29.98	335	4	P	H	
	*	2437	108.83	-	-	93.11	27.35	18.35	29.98	335	4	A	H	
			2486.07	57.47	-16.53	74	41.59	27.47	18.38	29.97	335	4	P	H
			2483.69	47.79	-6.21	54	31.92	27.46	18.38	29.97	335	4	A	H
			2389.52	57.23	-16.77	74	41.68	27.23	18.31	29.99	134	274	P	V
			2386.86	45	-9	54	29.45	27.23	18.31	29.99	134	274	A	V
	*		2437	113.48	-	-	97.76	27.35	18.35	29.98	134	274	P	V
	*		2437	110.35	-	-	94.63	27.35	18.35	29.98	134	274	A	V
			2484.39	58.53	-15.47	74	42.66	27.46	18.38	29.97	134	274	P	V
			2483.62	49.08	-4.92	54	33.21	27.46	18.38	29.97	134	274	A	V



802.11b CH 11 2462MHz	*	2462	108.88	-	-	93.07	27.41	18.37	29.97	322	3	P	H
	*	2462	105.72	-	-	89.91	27.41	18.37	29.97	322	3	A	H
		2488.08	57.09	-16.91	74	41.21	27.47	18.38	29.97	322	3	P	H
		2483.52	50.62	-3.38	54	34.75	27.46	18.38	29.97	322	3	A	H
													H
													H
	*	2462	111.69	-	-	95.88	27.41	18.37	29.97	125	274	P	V
	*	2462	108.49	-	-	92.68	27.41	18.37	29.97	125	274	A	V
		2483.52	58.96	-15.04	74	43.09	27.46	18.38	29.97	125	274	P	V
		2483.52	50.75	-3.25	54	34.88	27.46	18.38	29.97	125	274	A	V
													V
													V
Remark	1. No other spurious found. 2. All results are PASS against Peak and Average limit line.												



2.4GHz 2400~2483.5MHz
WIFI 802.11b (Harmonic @ 3m)

WIFI Ant. 1	Note	Frequency (MHz)	Level (dBμV/m)	Over Limit (dB)	Limit Line (dBμV/m)	Read Level (dBμV)	Antenna Factor (dB/m)	Path Loss (dB)	Preamp Factor (dB)	Ant Pos (cm)	Table Pos (deg)	Peak Avg. (P/A)	Pol. (H/V)	
802.11b CH 01 2412MHz		4824	48.98	-25.02	74	62.51	31.25	13.76	58.54	100	0	P	H	
													H	
													H	
													H	
			4824	52.4	-21.6	74	65.93	31.25	13.76	58.54	177	285	P	V
			4824	50.24	-3.76	54	63.77	31.25	13.76	58.54	177	285	A	V
														V
802.11b CH 06 2437MHz		4874	46.95	-27.05	74	60.29	31.35	13.84	58.53	100	0	P	H	
		7311	43.24	-30.76	74	50.92	36.07	15.22	58.97	100	0	P	H	
													H	
													H	
			4874	51.49	-22.51	74	64.83	31.35	13.84	58.53	152	320	P	V
			4874	49.39	-4.61	54	62.73	31.35	13.84	58.53	152	320	A	V
			7311	44.44	-29.56	74	52.12	36.07	15.22	58.97	100	0	P	V
802.11b CH 11 2462MHz		4924	48.76	-25.24	74	61.91	31.45	13.92	58.52	100	0	P	H	
		7386	43.02	-30.98	74	50.49	36.28	15.15	58.9	100	0	P	H	
													H	
													H	
			4924	45.89	-28.11	74	59.04	31.45	13.92	58.52	100	0	P	V
			7386	42.68	-31.32	74	50.15	36.28	15.15	58.9	100	0	P	V
														V
Remark	1. No other spurious found.													
	2. All results are PASS against Peak and Average limit line.													



2.4GHz 2400~2483.5MHz
WIFI 802.11g (Band Edge @ 3m)

WIFI Ant. 1	Note	Frequency (MHz)	Level (dBμV/m)	Over Limit (dB)	Limit Line (dBμV/m)	Read Level (dBμV)	Antenna Factor (dB/m)	Path Loss (dB)	Preamp Factor (dB)	Ant Pos (cm)	Table Pos (deg)	Peak Avg. (P/A)	Pol. (H/V)	
802.11g CH 01 2412MHz		2389.8	62.39	-11.61	74	46.82	27.24	18.32	29.99	340	3	P	H	
		2390	49.86	-4.14	54	34.29	27.24	18.32	29.99	340	3	A	H	
	*	2412	111.5	-	-	95.86	27.29	18.34	29.99	340	3	P	H	
	*	2412	103.57	-	-	87.93	27.29	18.34	29.99	340	3	A	H	
													H	
													H	
			2389.38	63.67	-10.33	74	48.12	27.23	18.31	29.99	120	272	P	V
			2390	50.52	-3.48	54	34.95	27.24	18.32	29.99	120	272	A	V
	*		2412	113.19	-	-	97.55	27.29	18.34	29.99	120	272	P	V
	*		2412	105.29	-	-	89.65	27.29	18.34	29.99	120	272	A	V
													V	
													V	
802.11g CH 06 2437MHz		2389.38	58.14	-15.86	74	42.59	27.23	18.31	29.99	335	2	P	H	
		2389.94	47.95	-6.05	54	32.38	27.24	18.32	29.99	335	2	A	H	
	*	2437	114.25	-	-	98.53	27.35	18.35	29.98	335	2	P	H	
	*	2437	106.64	-	-	90.92	27.35	18.35	29.98	335	2	A	H	
			2483.55	60.41	-13.59	74	44.54	27.46	18.38	29.97	335	2	P	H
			2483.5	49.39	-4.61	54	33.52	27.46	18.38	29.97	335	2	A	H
			2389.52	58.08	-15.92	74	42.53	27.23	18.31	29.99	141	274	P	V
			2389.94	48.59	-5.41	54	33.02	27.24	18.32	29.99	141	274	A	V
	*		2437	116.13	-	-	100.41	27.35	18.35	29.98	141	274	P	V
	*		2437	108.3	-	-	92.58	27.35	18.35	29.98	141	274	A	V
			2483.55	62.65	-11.35	74	46.78	27.46	18.38	29.97	141	274	P	V
			2483.5	50.95	-3.05	54	35.08	27.46	18.38	29.97	141	274	A	V



802.11g CH 11 2462MHz	*	2462	111.47	-	-	95.66	27.41	18.37	29.97	326	3	P	H
	*	2462	103.75	-	-	87.94	27.41	18.37	29.97	326	3	A	H
		2483.64	59.61	-14.39	74	43.74	27.46	18.38	29.97	326	3	P	H
		2483.52	48.86	-5.14	54	32.99	27.46	18.38	29.97	326	3	A	H
													H
													H
	*	2462	113.38	-	-	97.57	27.41	18.37	29.97	128	275	P	V
	*	2462	105.89	-	-	90.08	27.41	18.37	29.97	128	275	A	V
		2484.16	62.77	-11.23	74	46.9	27.46	18.38	29.97	128	275	P	V
		2483.52	50.39	-3.61	54	34.52	27.46	18.38	29.97	128	275	A	V
													V
													V
Remark	1. No other spurious found. 2. All results are PASS against Peak and Average limit line.												



**2.4GHz 2400~2483.5MHz
WIFI 802.11g (Harmonic @ 3m)**

WIFI Ant. 1	Note	Frequency (MHz)	Level (dBμV/m)	Over Limit (dB)	Limit Line (dBμV/m)	Read Level (dBμV)	Antenna Factor (dB/m)	Path Loss (dB)	Preamp Factor (dB)	Ant Pos (cm)	Table Pos (deg)	Peak Avg. (P/A)	Pol. (H/V)
802.11g CH 01 2412MHz		4824	46.14	-27.86	74	59.67	31.25	13.76	58.54	100	0	P	H
													H
													H
													H
		4824	47.6	-26.4	74	61.13	31.25	13.76	58.54	100	0	P	V
													V
													V
802.11g CH 06 2437MHz		4874	47.15	-26.85	74	60.49	31.35	13.84	58.53	100	0	P	H
		7311	44.05	-29.95	74	51.73	36.07	15.22	58.97	100	0	P	H
													H
													H
		4874	46.72	-27.28	74	60.06	31.35	13.84	58.53	100	0	P	V
		7311	43.95	-30.05	74	51.63	36.07	15.22	58.97	100	0	P	V
													V
802.11g CH 11 2462MHz		4924	44.68	-29.32	74	57.83	31.45	13.92	58.52	100	0	P	H
		7386	43.11	-30.89	74	50.58	36.28	15.15	58.9	100	0	P	H
													H
													H
		4924	43.8	-30.2	74	56.95	31.45	13.92	58.52	100	0	P	V
		7386	42.76	-31.24	74	50.23	36.28	15.15	58.9	100	0	P	V
													V
Remark	1. No other spurious found. 2. All results are PASS against Peak and Average limit line.												



**2.4GHz 2400~2483.5MHz
WIFI 802.11n HT20 (Band Edge @ 3m)**

WIFI Ant. 1	Note	Frequency (MHz)	Level (dBμV/m)	Over Limit (dB)	Limit Line (dBμV/m)	Read Level (dBμV)	Antenna Factor (dB/m)	Path Loss (dB)	Preamp Factor (dB)	Ant Pos (cm)	Table Pos (deg)	Peak Avg. (P/A)	Pol. (H/V)	
802.11n HT20 CH 01 2412MHz		2389.485	63.73	-10.27	74	48.18	27.23	18.31	29.99	339	1	P	H	
		2390	49.09	-4.91	54	33.52	27.24	18.32	29.99	339	1	A	H	
	*	2412	107.95	-	-	92.31	27.29	18.34	29.99	339	1	P	H	
	*	2412	100.21	-	-	84.57	27.29	18.34	29.99	339	1	A	H	
													H	
													H	
			2389.8	66.79	-7.21	74	51.22	27.24	18.32	29.99	121	288	P	V
			2390	50.69	-3.31	54	35.12	27.24	18.32	29.99	121	288	A	V
		*	2412	111.3	-	-	95.66	27.29	18.34	29.99	121	288	P	V
		*	2412	103.37	-	-	87.73	27.29	18.34	29.99	121	288	A	V
													V	
													V	
802.11n HT20 CH 06 2437MHz		2389.94	58.94	-15.06	74	43.37	27.24	18.32	29.99	264	235	P	H	
		2389.94	47.6	-6.4	54	32.03	27.24	18.32	29.99	264	235	A	H	
	*	2437	113.05	-	-	97.33	27.35	18.35	29.98	264	235	P	H	
	*	2437	105.07	-	-	89.35	27.35	18.35	29.98	264	235	A	H	
			2484.39	61.14	-12.86	74	45.27	27.46	18.38	29.97	264	235	P	H
			2483.5	47.9	-6.1	54	32.03	27.46	18.38	29.97	264	235	A	H
			2388.54	59.28	-14.72	74	43.73	27.23	18.31	29.99	136	275	P	V
			2389.94	47.27	-6.73	54	31.7	27.24	18.32	29.99	136	275	A	V
		*	2437	113.81	-	-	98.09	27.35	18.35	29.98	136	275	P	V
		*	2437	105.3	-	-	89.58	27.35	18.35	29.98	136	275	A	V
		2484.6	64.3	-9.7	74	48.43	27.46	18.38	29.97	136	275	P	V	
		2483.5	50.53	-3.47	54	34.66	27.46	18.38	29.97	136	275	A	V	



802.11n HT20 CH 11 2462MHz	*	2462	110.13	-	-	94.32	27.41	18.37	29.97	238	29	P	H
	*	2462	102.37	-	-	86.56	27.41	18.37	29.97	238	29	A	H
		2484.08	61.86	-12.14	74	45.99	27.46	18.38	29.97	238	29	P	H
		2483.52	48.08	-5.92	54	32.21	27.46	18.38	29.97	238	29	A	H
													H
													H
	*	2462	111.83	-	-	96.02	27.41	18.37	29.97	124	278	P	V
	*	2462	104.31	-	-	88.5	27.41	18.37	29.97	124	278	A	V
		2483.68	64.95	-9.05	74	49.08	27.46	18.38	29.97	124	278	P	V
		2483.52	49.95	-4.05	54	34.08	27.46	18.38	29.97	124	278	A	V
													V
													V
Remark	1. No other spurious found. 2. All results are PASS against Peak and Average limit line.												



**2.4GHz 2400~2483.5MHz
WIFI 802.11n HT20 (Harmonic @ 3m)**

WIFI Ant. 1	Note	Frequency (MHz)	Level (dBμV/m)	Over Limit (dB)	Limit Line (dBμV/m)	Read Level (dBμV)	Antenna Factor (dB/m)	Path Loss (dB)	Preamp Factor (dB)	Ant Pos (cm)	Table Pos (deg)	Peak Avg. (P/A)	Pol. (H/V)	
802.11n HT20 CH 01 2412MHz		4824	44.61	-29.39	74	58.14	31.25	13.76	58.54	100	0	P	H	
													H	
													H	
													H	
			4824	46.6	-27.4	74	60.13	31.25	13.76	58.54	100	0	P	V
														V
														V
802.11n HT20 CH 06 2437MHz		4874	45.13	-28.87	74	58.47	31.35	13.84	58.53	100	0	P	H	
													H	
			7311	43.38	-30.62	74	51.06	36.07	15.22	58.97	100	0	P	H
														H
			4874	45.01	-28.99	74	58.35	31.35	13.84	58.53	100	0	P	V
			7311	42.5	-31.5	74	50.18	36.07	15.22	58.97	100	0	P	V
														V
802.11n HT20 CH 11 2462MHz		4924	44.14	-29.86	74	57.29	31.45	13.92	58.52	100	0	P	H	
													H	
			7386	43.25	-30.75	74	50.72	36.28	15.15	58.9	100	0	P	H
														H
			4924	42.6	-31.4	74	55.75	31.45	13.92	58.52	100	0	P	V
			7386	42.51	-31.49	74	49.98	36.28	15.15	58.9	100	0	P	V
														V
Remark	1. No other spurious found.													
	2. All results are PASS against Peak and Average limit line.													



**2.4GHz 2400~2483.5MHz
WIFI 802.11n HT40 (Band Edge @ 3m)**

WIFI Ant. 1	Note	Frequency (MHz)	Level (dBμV/m)	Over Limit (dB)	Limit Line (dBμV/m)	Read Level (dBμV)	Antenna Factor (dB/m)	Path Loss (dB)	Preamp Factor (dB)	Ant Pos (cm)	Table Pos (deg)	Peak Avg. (P/A)	Pol. (H/V)
802.11n HT40 CH 03 2422MHz		2389.94	60.69	-13.31	74	45.12	27.24	18.32	29.99	207	28	P	H
		2389.66	50.65	-3.35	54	35.08	27.24	18.32	29.99	207	28	A	H
	*	2422	107.68	-	-	92.01	27.31	18.34	29.98	207	28	P	H
	*	2422	99.8	-	-	84.13	27.31	18.34	29.98	207	28	A	H
		2485.92	56.91	-17.09	74	41.03	27.47	18.38	29.97	207	28	P	H
		2484.08	47.28	-6.72	54	31.41	27.46	18.38	29.97	207	28	A	H
		2389.8	60.34	-13.66	74	44.77	27.24	18.32	29.99	163	306	P	V
		2389.94	50.78	-3.22	54	35.21	27.24	18.32	29.99	163	306	A	V
	*	2422	107.68	-	-	92.01	27.31	18.34	29.98	163	306	P	V
	*	2422	99.88	-	-	84.21	27.31	18.34	29.98	163	306	A	V
		2485.92	57.81	-16.19	74	41.93	27.47	18.38	29.97	163	306	P	V
		2483.52	47.37	-6.63	54	31.5	27.46	18.38	29.97	163	306	A	V
802.11n HT40 CH 06 2437MHz		2389.8	57.15	-16.85	74	41.58	27.24	18.32	29.99	274	32	P	H
		2389.38	47.95	-6.05	54	32.4	27.23	18.31	29.99	274	32	A	H
	*	2437	108.67	-	-	92.95	27.35	18.35	29.98	274	32	P	H
	*	2437	99.95	-	-	84.23	27.35	18.35	29.98	274	32	A	H
		2483.76	59.22	-14.78	74	43.35	27.46	18.38	29.97	274	32	P	H
		2483.6	49.9	-4.1	54	34.03	27.46	18.38	29.97	274	32	A	H
		2389.94	57.76	-16.24	74	42.19	27.24	18.32	29.99	114	200	P	V
		2388.82	48	-6	54	32.45	27.23	18.31	29.99	114	200	A	V
	*	2437	109.38	-	-	93.66	27.35	18.35	29.98	114	200	P	V
	*	2437	101.59	-	-	85.87	27.35	18.35	29.98	114	200	A	V
		2483.52	58.82	-15.18	74	42.95	27.46	18.38	29.97	114	200	P	V
		2483.68	50.59	-3.41	54	34.72	27.46	18.38	29.97	114	200	A	V



802.11n HT40 CH 09 2452MHz		2387.7	56.44	-17.56	74	40.89	27.23	18.31	29.99	268	32	P	H
		2381.82	46.3	-7.7	54	30.77	27.22	18.3	29.99	268	32	A	H
	*	2452	104.74	-	-	88.97	27.38	18.36	29.97	268	32	P	H
	*	2452	96.94	-	-	81.17	27.38	18.36	29.97	268	32	A	H
		2484.53	58.73	-15.27	74	42.86	27.46	18.38	29.97	268	32	P	H
		2484.6	50.52	-3.48	54	34.65	27.46	18.38	29.97	268	32	A	H
		2388.12	55.75	-18.25	74	40.2	27.23	18.31	29.99	139	233	P	V
		2366	46.37	-7.63	54	30.9	27.18	18.28	29.99	139	233	A	V
	*	2452	106.81	-	-	91.04	27.38	18.36	29.97	139	233	P	V
	*	2452	99.13	-	-	83.36	27.38	18.36	29.97	139	233	A	V
		2486.84	59.84	-14.16	74	43.96	27.47	18.38	29.97	139	233	P	V
		2483.55	50.67	-3.33	54	34.8	27.46	18.38	29.97	139	233	A	V
Remark	1. No other spurious found. 2. All results are PASS against Peak and Average limit line.												



**2.4GHz 2400~2483.5MHz
WIFI 802.11n HT40 (Harmonic @ 3m)**

WIFI Ant. 1	Note	Frequency (MHz)	Level (dBμV/m)	Over Limit (dB)	Limit Line (dBμV/m)	Read Level (dBμV)	Antenna Factor (dB/m)	Path Loss (dB)	Preamp Factor (dB)	Ant Pos (cm)	Table Pos (deg)	Peak Avg. (P/A)	Pol. (H/V)
802.11n HT40 CH 03 2422MHz		4844	40.77	-33.23	74	54.22	31.29	13.79	58.53	100	0	P	H
		7266	42.77	-31.23	74	50.58	35.94	15.26	59.01	100	0	P	H
													H
													H
		4844	40.53	-33.47	74	53.98	31.29	13.79	58.53	100	0	P	V
		7266	42.88	-31.12	74	50.69	35.94	15.26	59.01	100	0	P	V
802.11n HT40 CH 06 2437MHz		4874	41.22	-32.78	74	54.56	31.35	13.84	58.53	100	0	P	H
		7311	43.06	-30.94	74	50.74	36.07	15.22	58.97	100	0	P	H
													H
													H
		4874	40.68	-33.32	74	54.02	31.35	13.84	58.53	100	0	P	V
		7311	42.66	-31.34	74	50.34	36.07	15.22	58.97	100	0	P	V
802.11n HT40 CH 09 2452MHz		4904	40.54	-33.46	74	53.76	31.41	13.89	58.52	100	0	P	H
		7356	43.07	-30.93	74	50.62	36.2	15.18	58.93	100	0	P	H
													H
													H
		4904	40.11	-33.89	74	53.33	31.41	13.89	58.52	100	0	P	V
		7356	43.25	-30.75	74	50.8	36.2	15.18	58.93	100	0	P	V
Remark	1. No other spurious found.												
	2. All results are PASS against Peak and Average limit line.												



2.4GHz 2400~2483.5MHz
WIFI 802.11b (Band Edge @ 3m)

WIFI Ant. 2	Note	Frequency (MHz)	Level (dBμV/m)	Over Limit (dB)	Limit Line (dBμV/m)	Read Level (dBμV)	Antenna Factor (dB/m)	Path Loss (dB)	Preamp Factor (dB)	Ant Pos (cm)	Table Pos (deg)	Peak Avg. (P/A)	Pol. (H/V)	
802.11b CH 01 2412MHz		2387.07	57.32	-16.68	74	41.77	27.23	18.31	29.99	283	311	P	H	
		2387.595	50.16	-3.84	54	34.61	27.23	18.31	29.99	283	311	A	H	
	*	2412	112.91	-	-	97.27	27.29	18.34	29.99	283	311	P	H	
	*	2412	109.82	-	-	94.18	27.29	18.34	29.99	283	311	A	H	
													H	
														H
			2390	57.27	-16.73	74	41.7	27.24	18.32	29.99	100	254	P	V
			2387.805	49.02	-4.98	54	33.47	27.23	18.31	29.99	100	254	A	V
	*		2412	112.17	-	-	96.53	27.29	18.34	29.99	100	254	P	V
	*		2412	107.96	-	-	92.32	27.29	18.34	29.99	100	254	A	V
														V
														V
802.11b CH 06 2437MHz		2373	56.5	-17.5	74	41	27.2	18.29	29.99	280	312	P	H	
		2389.94	45.37	-8.63	54	29.8	27.24	18.32	29.99	280	312	A	H	
	*	2437	114.57	-	-	98.85	27.35	18.35	29.98	280	312	P	H	
	*	2437	109.62	-	-	93.9	27.35	18.35	29.98	280	312	A	H	
			2484.04	57.6	-16.4	74	41.73	27.46	18.38	29.97	280	312	P	H
			2485.23	47.67	-6.33	54	31.8	27.46	18.38	29.97	280	312	A	H
			2338.98	56.29	-17.71	74	40.94	27.11	18.24	30	100	255	P	V
			2389.94	45.17	-8.83	54	29.6	27.24	18.32	29.99	100	255	A	V
	*		2437	111.75	-	-	96.03	27.35	18.35	29.98	100	255	P	V
	*		2437	108.52	-	-	92.8	27.35	18.35	29.98	100	255	A	V
			2487.54	58.14	-15.86	74	42.26	27.47	18.38	29.97	100	255	P	V
			2484.46	46.28	-7.72	54	30.41	27.46	18.38	29.97	100	255	A	V



802.11b CH 11 2462MHz	*	2462	113.01	-	-	97.2	27.41	18.37	29.97	275	310	P	H
	*	2462	109.65	-	-	93.84	27.41	18.37	29.97	275	310	A	H
		2488.96	58.84	-15.16	74	42.96	27.47	18.38	29.97	275	310	P	H
		2483.5	50.83	-3.17	54	34.96	27.46	18.38	29.97	275	310	A	H
													H
													H
	*	2462	111.71	-	-	95.9	27.41	18.37	29.97	116	256	P	V
	*	2462	108.27	-	-	92.46	27.41	18.37	29.97	116	256	A	V
		2483.68	58.54	-15.46	74	42.67	27.46	18.38	29.97	116	256	P	V
		2486.84	47.03	-6.97	54	31.15	27.47	18.38	29.97	116	256	A	V
													V
													V
Remark	1. No other spurious found. 2. All results are PASS against Peak and Average limit line.												



**2.4GHz 2400~2483.5MHz
WIFI 802.11b (Harmonic @ 3m)**

WIFI Ant. 2	Note	Frequency (MHz)	Level (dBμV/m)	Over Limit (dB)	Limit Line (dBμV/m)	Read Level (dBμV)	Antenna Factor (dB/m)	Path Loss (dB)	Preamp Factor (dB)	Ant Pos (cm)	Table Pos (deg)	Peak Avg. (P/A)	Pol. (H/V)	
802.11b CH 01 2412MHz		4824	46.76	-27.24	74	60.29	31.25	13.76	58.54	100	0	P	H	
													H	
													H	
													H	
			4824	42.93	-31.07	74	56.46	31.25	13.76	58.54	100	0	P	V
														V
														V
802.11b CH 06 2437MHz		4874	44.64	-29.36	74	57.98	31.35	13.84	58.53	100	0	P	H	
		7311	43.35	-30.65	74	51.03	36.07	15.22	58.97	100	0	P	H	
													H	
													H	
			4874	42.7	-31.3	74	56.04	31.35	13.84	58.53	100	0	P	V
			7311	43.14	-30.86	74	50.82	36.07	15.22	58.97	100	0	P	V
														V
802.11b CH 11 2462MHz		4924	45.9	-28.1	74	59.05	31.45	13.92	58.52	100	0	P	H	
		7386	43.29	-30.71	74	50.76	36.28	15.15	58.9	100	0	P	H	
													H	
													H	
			4924	43.26	-30.74	74	56.41	31.45	13.92	58.52	100	0	P	V
			7386	43.09	-30.91	74	50.56	36.28	15.15	58.9	100	0	P	V
														V
Remark	1. No other spurious found. 2. All results are PASS against Peak and Average limit line.													



2.4GHz 2400~2483.5MHz
WIFI 802.11g (Band Edge @ 3m)

WIFI Ant. 2	Note	Frequency (MHz)	Level (dBμV/m)	Over Limit (dB)	Limit Line (dBμV/m)	Read Level (dBμV)	Antenna Factor (dB/m)	Path Loss (dB)	Preamp Factor (dB)	Ant Pos (cm)	Table Pos (deg)	Peak Avg. (P/A)	Pol. (H/V)	
802.11g CH 01 2412MHz		2389.8	62.77	-11.23	74	47.2	27.24	18.32	29.99	318	310	P	H	
		2390	50.83	-3.17	54	35.26	27.24	18.32	29.99	318	310	A	H	
	*	2412	112.75	-	-	97.11	27.29	18.34	29.99	318	310	P	H	
	*	2412	105.14	-	-	89.5	27.29	18.34	29.99	318	310	A	H	
													H	
														H
			2389.8	64.91	-9.09	74	49.34	27.24	18.32	29.99	113	254	P	V
			2390	50.14	-3.86	54	34.57	27.24	18.32	29.99	113	254	A	V
	*		2412	110.66	-	-	95.02	27.29	18.34	29.99	113	254	P	V
	*		2412	102.72	-	-	87.08	27.29	18.34	29.99	113	254	A	V
														V
														V
802.11g CH 06 2437MHz		2387.98	58.24	-15.76	74	42.69	27.23	18.31	29.99	279	312	P	H	
		2389.94	48.82	-5.18	54	33.25	27.24	18.32	29.99	279	312	A	H	
	*	2437	116.56	-	-	100.84	27.35	18.35	29.98	279	312	P	H	
	*	2437	109.31	-	-	93.59	27.35	18.35	29.98	279	312	A	H	
			2483.97	62.52	-11.48	74	46.65	27.46	18.38	29.97	279	312	P	H
			2483.5	50.63	-3.37	54	34.76	27.46	18.38	29.97	279	312	A	H
			2389.94	58.72	-15.28	74	43.15	27.24	18.32	29.99	118	254	P	V
			2389.94	48.25	-5.75	54	32.68	27.24	18.32	29.99	118	254	A	V
	*		2437	114.67	-	-	98.95	27.35	18.35	29.98	118	254	P	V
	*		2437	107.3	-	-	91.58	27.35	18.35	29.98	118	254	A	V
			2484.74	60.4	-13.6	74	44.53	27.46	18.38	29.97	118	254	P	V
			2483.55	48.64	-5.36	54	32.77	27.46	18.38	29.97	118	254	A	V



802.11g CH 11 2462MHz	*	2462	113.21	-	-	97.4	27.41	18.37	29.97	276	313	P	H
	*	2462	105.5	-	-	89.69	27.41	18.37	29.97	276	313	A	H
		2484.88	65.24	-8.76	74	49.37	27.46	18.38	29.97	276	313	P	H
		2483.52	49.79	-4.21	54	33.92	27.46	18.38	29.97	276	313	A	H
													H
													H
	*	2462	112.17	-	-	96.36	27.41	18.37	29.97	115	255	P	V
	*	2462	104.18	-	-	88.37	27.41	18.37	29.97	115	255	A	V
		2484.88	60.8	-13.2	74	44.93	27.46	18.38	29.97	115	255	P	V
		2483.52	48.76	-5.24	54	32.89	27.46	18.38	29.97	115	255	A	V
													V
													V
Remark	1. No other spurious found. 2. All results are PASS against Peak and Average limit line.												



2.4GHz 2400~2483.5MHz
WIFI 802.11g (Harmonic @ 3m)

WIFI Ant. 2	Note	Frequency (MHz)	Level (dBμV/m)	Over Limit (dB)	Limit Line (dBμV/m)	Read Level (dBμV)	Antenna Factor (dB/m)	Path Loss (dB)	Preamp Factor (dB)	Ant Pos (cm)	Table Pos (deg)	Peak Avg. (P/A)	Pol. (H/V)
802.11g CH 01 2412MHz		4824	41.74	-32.26	74	55.27	31.25	13.76	58.54	100	0	P	H
													H
													H
													H
		4824	42.65	-31.35	74	56.18	31.25	13.76	58.54	100	0	P	V
													V
													V
802.11g CH 06 2437MHz		4874	42.38	-31.62	74	55.72	31.35	13.84	58.53	100	0	P	H
		7311	43.8	-30.2	74	51.48	36.07	15.22	58.97	100	0	P	H
													H
													H
		4874	40.45	-33.55	74	53.79	31.35	13.84	58.53	100	0	P	V
		7311	43.47	-30.53	74	51.15	36.07	15.22	58.97	100	0	P	V
													V
802.11g CH 11 2462MHz		4924	42.2	-31.8	74	55.35	31.45	13.92	58.52	100	0	P	H
		7386	43.45	-30.55	74	50.92	36.28	15.15	58.9	100	0	P	H
													H
													H
		4924	41.26	-32.74	74	54.41	31.45	13.92	58.52	100	0	P	V
		7386	42.89	-31.11	74	50.36	36.28	15.15	58.9	100	0	P	V
													V
Remark	1. No other spurious found. 2. All results are PASS against Peak and Average limit line.												



**2.4GHz 2400~2483.5MHz
WIFI 802.11n HT20 (Band Edge @ 3m)**

WIFI Ant. 2	Note	Frequency (MHz)	Level (dBμV/m)	Over Limit (dB)	Limit Line (dBμV/m)	Read Level (dBμV)	Antenna Factor (dB/m)	Path Loss (dB)	Preamp Factor (dB)	Ant Pos (cm)	Table Pos (deg)	Peak Avg. (P/A)	Pol. (H/V)	
802.11n HT20 CH 01 2412MHz		2389.59	63.82	-10.18	74	48.26	27.24	18.31	29.99	320	310	P	H	
		2390	50.86	-3.14	54	35.29	27.24	18.32	29.99	320	310	A	H	
	*	2412	112.1	-	-	96.46	27.29	18.34	29.99	320	310	P	H	
	*	2412	104.57	-	-	88.93	27.29	18.34	29.99	320	310	A	H	
													H	
													H	
			2390	65.17	-8.83	74	49.6	27.24	18.32	29.99	100	254	P	V
			2390	49.56	-4.44	54	33.99	27.24	18.32	29.99	100	254	A	V
		*	2412	110.66	-	-	95.02	27.29	18.34	29.99	100	254	P	V
		*	2412	102.64	-	-	87	27.29	18.34	29.99	100	254	A	V
													V	
													V	
802.11n HT20 CH 06 2437MHz		2389.66	60.12	-13.88	74	44.55	27.24	18.32	29.99	285	312	P	H	
		2389.94	48.9	-5.1	54	33.33	27.24	18.32	29.99	285	312	A	H	
	*	2437	117.05	-	-	101.33	27.35	18.35	29.98	285	312	P	H	
	*	2437	108.77	-	-	93.05	27.35	18.35	29.98	285	312	A	H	
			2483.55	63.94	-10.06	74	48.07	27.46	18.38	29.97	285	312	P	H
			2483.5	50.58	-3.42	54	34.71	27.46	18.38	29.97	285	312	A	H
			2389.94	58.69	-15.31	74	43.12	27.24	18.32	29.99	118	253	P	V
			2389.94	48.39	-5.61	54	32.82	27.24	18.32	29.99	118	253	A	V
		*	2437	114.72	-	-	99	27.35	18.35	29.98	118	253	P	V
		*	2437	106.84	-	-	91.12	27.35	18.35	29.98	118	253	A	V
		2484.32	61.05	-12.95	74	45.18	27.46	18.38	29.97	118	253	P	V	
		2483.5	48.69	-5.31	54	32.82	27.46	18.38	29.97	118	253	A	V	



802.11n HT20 CH 11 2462MHz	*	2462	113	-	-	97.19	27.41	18.37	29.97	280	311	P	H
	*	2462	105.28	-	-	89.47	27.41	18.37	29.97	280	311	A	H
		2484.64	63.65	-10.35	74	47.78	27.46	18.38	29.97	280	311	P	H
		2483.52	49.98	-4.02	54	34.11	27.46	18.38	29.97	280	311	A	H
													H
													H
	*	2462	111.78	-	-	95.97	27.41	18.37	29.97	114	256	P	V
	*	2462	103.94	-	-	88.13	27.41	18.37	29.97	114	256	A	V
		2489.68	61.23	-12.77	74	45.34	27.48	18.38	29.97	114	256	P	V
		2483.56	49.56	-4.44	54	33.69	27.46	18.38	29.97	114	256	A	V
													V
													V
Remark	1. No other spurious found. 2. All results are PASS against Peak and Average limit line.												



2.4GHz 2400~2483.5MHz
WIFI 802.11n HT20 (Harmonic @ 3m)

WIFI Ant. 2	Note	Frequency (MHz)	Level (dBμV/m)	Over Limit (dB)	Limit Line (dBμV/m)	Read Level (dBμV)	Antenna Factor (dB/m)	Path Loss (dB)	Preamp Factor (dB)	Ant Pos (cm)	Table Pos (deg)	Peak Avg. (P/A)	Pol. (H/V)	
802.11n HT20 CH 01 2412MHz		4824	40.63	-33.37	74	54.16	31.25	13.76	58.54	100	0	P	H	
													H	
													H	
													H	
			4824	39.77	-34.23	74	53.3	31.25	13.76	58.54	100	0	P	V
														V
														V
802.11n HT20 CH 06 2437MHz		4874	42.73	-31.27	74	56.07	31.35	13.84	58.53	100	0	P	H	
		7311	43.55	-30.45	74	51.23	36.07	15.22	58.97	100	0	P	H	
													H	
													H	
			4874	39.68	-34.32	74	53.02	31.35	13.84	58.53	100	0	P	V
			7311	43.02	-30.98	74	50.7	36.07	15.22	58.97	100	0	P	V
														V
802.11n HT20 CH 11 2462MHz		4924	42.34	-31.66	74	55.49	31.45	13.92	58.52	100	0	P	H	
		7386	42.51	-31.49	74	49.98	36.28	15.15	58.9	100	0	P	H	
													H	
													H	
			4924	40.43	-33.57	74	53.58	31.45	13.92	58.52	100	0	P	V
			7386	43.06	-30.94	74	50.53	36.28	15.15	58.9	100	0	P	V
														V
Remark	1. No other spurious found.													
	2. All results are PASS against Peak and Average limit line.													



**2.4GHz 2400~2483.5MHz
WIFI 802.11n HT40 (Band Edge @ 3m)**

WIFI Ant. 2	Note	Frequency (MHz)	Level (dBμV/m)	Over Limit (dB)	Limit Line (dBμV/m)	Read Level (dBμV)	Antenna Factor (dB/m)	Path Loss (dB)	Preamp Factor (dB)	Ant Pos (cm)	Table Pos (deg)	Peak Avg. (P/A)	Pol. (H/V)
802.11n HT40 CH 03 2422MHz		2388.82	59.02	-14.98	74	43.47	27.23	18.31	29.99	273	310	P	H
		2389.52	50.85	-3.15	54	35.3	27.23	18.31	29.99	273	310	A	H
	*	2422	107.21	-	-	91.54	27.31	18.34	29.98	273	310	P	H
	*	2422	99.78	-	-	84.11	27.31	18.34	29.98	273	310	A	H
		2488.45	56.86	-17.14	74	40.98	27.47	18.38	29.97	273	310	P	H
		2484.18	47.5	-6.5	54	31.63	27.46	18.38	29.97	273	310	A	H
		2389.94	57.54	-16.46	74	41.97	27.24	18.32	29.99	118	254	P	V
		2389.52	50.62	-3.38	54	35.07	27.23	18.31	29.99	118	254	A	V
	*	2422	106.03	-	-	90.36	27.31	18.34	29.98	118	254	P	V
	*	2422	98.28	-	-	82.61	27.31	18.34	29.98	118	254	A	V
		2494.33	56.3	-17.7	74	40.38	27.49	18.39	29.96	118	254	P	V
		2495.03	46.87	-7.13	54	30.95	27.49	18.39	29.96	118	254	A	V
802.11n HT40 CH 06 2437MHz		2389.94	56.71	-17.29	74	41.14	27.24	18.32	29.99	279	311	P	H
		2389.94	49.09	-4.91	54	33.52	27.24	18.32	29.99	279	311	A	H
	*	2437	109.7	-	-	93.98	27.35	18.35	29.98	279	311	P	H
	*	2437	101.69	-	-	85.97	27.35	18.35	29.98	279	311	A	H
		2483.9	59.29	-14.71	74	43.42	27.46	18.38	29.97	279	311	P	H
		2483.5	50.81	-3.19	54	34.94	27.46	18.38	29.97	279	311	A	H
		2389.52	57.54	-16.46	74	41.99	27.23	18.31	29.99	100	256	P	V
		2389.94	48.49	-5.51	54	32.92	27.24	18.32	29.99	100	256	A	V
	*	2437	108.51	-	-	92.79	27.35	18.35	29.98	100	256	P	V
	*	2437	100.63	-	-	84.91	27.35	18.35	29.98	100	256	A	V
	2483.83	58.26	-15.74	74	42.39	27.46	18.38	29.97	100	256	P	V	
	2483.62	49.45	-4.55	54	33.58	27.46	18.38	29.97	100	256	A	V	



802.11n HT40 CH 09 2452MHz		2317.56	56.79	-17.21	74	41.53	27.06	18.21	30.01	277	310	P	H
		2360.54	46.2	-7.8	54	30.76	27.17	18.27	30	277	310	A	H
	*	2452	107.24	-	-	91.47	27.38	18.36	29.97	277	310	P	H
	*	2452	99.18	-	-	83.41	27.38	18.36	29.97	277	310	A	H
		2483.62	59.97	-14.03	74	44.1	27.46	18.38	29.97	277	310	P	H
		2484.39	50.68	-3.32	54	34.81	27.46	18.38	29.97	277	310	A	H
		2357.04	56.81	-17.19	74	41.38	27.16	18.27	30	117	254	P	V
		2321.76	46.3	-7.7	54	31.02	27.07	18.22	30.01	117	254	A	V
	*	2452	105.8	-	-	90.03	27.38	18.36	29.97	117	254	P	V
	*	2452	97.8	-	-	82.03	27.38	18.36	29.97	117	254	A	V
		2484.74	58.51	-15.49	74	42.64	27.46	18.38	29.97	117	254	P	V
		2483.62	48.87	-5.13	54	33	27.46	18.38	29.97	117	254	A	V
Remark	1. No other spurious found. 2. All results are PASS against Peak and Average limit line.												



**2.4GHz 2400~2483.5MHz
WIFI 802.11n HT40 (Harmonic @ 3m)**

WIFI Ant. 2	Note	Frequency (MHz)	Level (dBμV/m)	Over Limit (dB)	Limit Line (dBμV/m)	Read Level (dBμV)	Antenna Factor (dB/m)	Path Loss (dB)	Preamp Factor (dB)	Ant Pos (cm)	Table Pos (deg)	Peak Avg. (P/A)	Pol. (H/V)
802.11n HT40 CH 03 2422MHz		4844	42.77	-31.23	74	56.22	31.29	13.79	58.53	100	0	P	H
		7266	42.73	-31.27	74	50.54	35.94	15.26	59.01	100	0	P	H
													H
													H
		4844	39.48	-34.52	74	52.93	31.29	13.79	58.53	100	0	P	V
		7266	42.86	-31.14	74	50.67	35.94	15.26	59.01	100	0	P	V
													V
													V
802.11n HT40 CH 06 2437MHz		4874	39.96	-34.04	74	53.3	31.35	13.84	58.53	100	0	P	H
		7311	44.08	-29.92	74	51.76	36.07	15.22	58.97	100	0	P	H
													H
													H
		4874	39.7	-34.3	74	53.04	31.35	13.84	58.53	100	0	P	V
		7311	43.24	-30.76	74	50.92	36.07	15.22	58.97	100	0	P	V
													V
													V
802.11n HT40 CH 09 2452MHz		4904	39	-35	74	52.22	31.41	13.89	58.52	100	0	P	H
		7356	43.51	-30.49	74	51.06	36.2	15.18	58.93	100	0	P	H
													H
													H
		4904	39.04	-34.96	74	52.26	31.41	13.89	58.52	100	0	P	V
		7356	43.64	-30.36	74	51.19	36.2	15.18	58.93	100	0	P	V
													V
													V
Remark	1. No other spurious found. 2. All results are PASS against Peak and Average limit line.												



**2.4GHz 2400~2483.5MHz
WIFI 802.11b (Band Edge @ 3m)**

WIFI Ant. 1+2	Note	Frequency (MHz)	Level (dBμV/m)	Over Limit (dB)	Limit Line (dBμV/m)	Read Level (dBμV)	Antenna Factor (dB/m)	Path Loss (dB)	Preamp Factor (dB)	Ant Pos (cm)	Table Pos (deg)	Peak Avg. (P/A)	Pol. (H/V)	
802.11b CH 01 2412MHz		2390	57.39	-16.61	74	41.82	27.24	18.32	29.99	105	315	P	H	
		2388.015	47.12	-6.88	54	31.57	27.23	18.31	29.99	105	315	A	H	
	*	2412	114.02	-	-	98.38	27.29	18.34	29.99	105	315	P	H	
	*	2412	111.22	-	-	95.58	27.29	18.34	29.99	105	315	A	H	
													H	
														H
			2388.12	57.1	-16.9	74	41.55	27.23	18.31	29.99	365	331	P	V
			2390	47.68	-6.32	54	32.11	27.24	18.32	29.99	365	331	A	V
	*		2412	112.71	-	-	97.07	27.29	18.34	29.99	365	331	P	V
	*		2412	109.31	-	-	93.67	27.29	18.34	29.99	365	331	A	V
														V
														V
802.11b CH 06 2437MHz		2389.94	58.23	-15.77	74	42.66	27.24	18.32	29.99	284	313	P	H	
		2388.26	48.79	-5.21	54	33.24	27.23	18.31	29.99	284	313	A	H	
	*	2437	117.28	-	-	101.56	27.35	18.35	29.98	284	313	P	H	
	*	2437	113.87	-	-	98.15	27.35	18.35	29.98	284	313	A	H	
			2483.55	59.16	-14.84	74	43.29	27.46	18.38	29.97	284	313	P	H
			2483.5	50.81	-3.19	54	34.94	27.46	18.38	29.97	284	313	A	H
			2389.1	57.53	-16.47	74	41.98	27.23	18.31	29.99	100	265	P	V
			2389.94	50.33	-3.67	54	34.76	27.24	18.32	29.99	100	265	A	V
	*		2437	114.84	-	-	99.12	27.35	18.35	29.98	100	265	P	V
	*		2437	111.63	-	-	95.91	27.35	18.35	29.98	100	265	A	V
			2485.86	57.62	-16.38	74	41.74	27.47	18.38	29.97	100	265	P	V
			2483.5	47.85	-6.15	54	31.98	27.46	18.38	29.97	100	265	A	V



802.11b CH 11 2462MHz	*	2462	112.24	-	-	96.43	27.41	18.37	29.97	304	309	P	H
	*	2462	109.43	-	-	93.62	27.41	18.37	29.97	304	309	A	H
		2486.12	59.02	-14.98	74	43.14	27.47	18.38	29.97	304	309	P	H
		2483.68	50.83	-3.17	54	34.96	27.46	18.38	29.97	304	309	A	H
													H
													H
	*	2462	111.94	-	-	96.13	27.41	18.37	29.97	197	324	P	V
	*	2462	108.78	-	-	92.97	27.41	18.37	29.97	197	324	A	V
		2483.52	58.31	-15.69	74	42.44	27.46	18.38	29.97	197	324	P	V
		2483.52	50.52	-3.48	54	34.65	27.46	18.38	29.97	197	324	A	V
													V
													V
Remark	1. No other spurious found. 2. All results are PASS against Peak and Average limit line.												



2.4GHz 2400~2483.5MHz
WIFI 802.11b (Harmonic @ 3m)

WIFI Ant. 1+2	Note	Frequency (MHz)	Level (dBμV/m)	Over Limit (dB)	Limit Line (dBμV/m)	Read Level (dBμV)	Antenna Factor (dB/m)	Path Loss (dB)	Preamp Factor (dB)	Ant Pos (cm)	Table Pos (deg)	Peak Avg. (P/A)	Pol. (H/V)	
802.11b CH 01 2412MHz		4824	52.77	-21.23	74	66.3	31.25	13.76	58.54	100	322	P	H	
		4824	50.91	-3.09	54	64.44	31.25	13.76	58.54	100	322	A	H	
													H	
													H	
			4824	49.75	-24.25	74	63.25	31.26	13.77	58.53	100	0	P	V
														V
														V
802.11b CH 06 2437MHz		4874	51.6	-22.4	74	64.94	31.35	13.84	58.53	100	322	P	H	
		4874	49.39	-4.61	54	62.73	31.35	13.84	58.53	100	322	A	H	
		7311	45.87	-28.13	74	53.55	36.07	15.22	58.97	100	0	P	H	
													H	
			4874	47.48	-26.52	74	60.82	31.35	13.84	58.53	100	0	P	V
			7311	43.08	-30.92	74	50.76	36.07	15.22	58.97	100	0	P	V
														V
802.11b CH 11 2462MHz		4924	48.8	-25.2	74	61.95	31.45	13.92	58.52	100	0	P	H	
		7386	43.06	-30.94	74	50.53	36.28	15.15	58.9	100	0	P	H	
													H	
													H	
			4924	46.03	-27.97	74	59.18	31.45	13.92	58.52	100	0	P	V
			7386	42.86	-31.14	74	50.33	36.28	15.15	58.9	100	0	P	V
														V
Remark	1. No other spurious found.													
	2. All results are PASS against Peak and Average limit line.													



2.4GHz 2400~2483.5MHz
WIFI 802.11g (Band Edge @ 3m)

WIFI Ant. 1+2	Note	Frequency (MHz)	Level (dBμV/m)	Over Limit (dB)	Limit Line (dBμV/m)	Read Level (dBμV)	Antenna Factor (dB/m)	Path Loss (dB)	Preamp Factor (dB)	Ant Pos (cm)	Table Pos (deg)	Peak Avg. (P/A)	Pol. (H/V)	
802.11g CH 01 2412MHz		2389.905	66.55	-7.45	74	50.98	27.24	18.32	29.99	334	131	P	H	
		2390	50.96	-3.04	54	35.39	27.24	18.32	29.99	334	131	A	H	
	*	2412	114.92	-	-	99.28	27.29	18.34	29.99	334	131	P	H	
	*	2412	107	-	-	91.36	27.29	18.34	29.99	334	131	A	H	
													H	
													H	
			2389.8	59.14	-14.86	74	43.57	27.24	18.32	29.99	100	79	P	V
			2390	46.32	-7.68	54	30.75	27.24	18.32	29.99	100	79	A	V
	*		2412	110.1	-	-	94.46	27.29	18.34	29.99	100	79	P	V
	*		2412	102.39	-	-	86.75	27.29	18.34	29.99	100	79	A	V
														V
														V
802.11g CH 06 2437MHz		2389.94	61.92	-12.08	74	46.35	27.24	18.32	29.99	365	132	P	H	
		2389.94	49.35	-4.65	54	33.78	27.24	18.32	29.99	365	132	A	H	
	*	2437	119.32	-	-	103.6	27.35	18.35	29.98	365	132	P	H	
	*	2437	112.44	-	-	96.72	27.35	18.35	29.98	365	132	A	H	
			2485.58	61.1	-12.9	74	45.22	27.47	18.38	29.97	365	132	P	H
			2484.88	48.11	-5.89	54	32.24	27.46	18.38	29.97	365	132	A	H
			2388.68	57.63	-16.37	74	42.08	27.23	18.31	29.99	153	86	P	V
			2389.94	45.41	-8.59	54	29.84	27.24	18.32	29.99	153	86	A	V
	*		2437	115.85	-	-	100.13	27.35	18.35	29.98	153	86	P	V
	*		2437	108.45	-	-	92.73	27.35	18.35	29.98	153	86	A	V
			2483.69	60.58	-13.42	74	44.71	27.46	18.38	29.97	153	86	P	V
			2483.5	47.22	-6.78	54	31.35	27.46	18.38	29.97	153	86	A	V



802.11g CH 11 2462MHz	*	2462	116.56	-	-	100.75	27.41	18.37	29.97	400	125	P	H
	*	2462	108.58	-	-	92.77	27.41	18.37	29.97	400	125	A	H
		2483.92	64.83	-9.17	74	48.96	27.46	18.38	29.97	400	125	P	H
		2483.72	50.15	-3.85	54	34.28	27.46	18.38	29.97	400	125	A	H
													H
													H
	*	2462	112.37	-	-	96.56	27.41	18.37	29.97	110	86	P	V
	*	2462	105.22	-	-	89.41	27.41	18.37	29.97	110	86	A	V
		2483.52	60	-14	74	44.13	27.46	18.38	29.97	110	86	P	V
		2483.52	47.96	-6.04	54	32.09	27.46	18.38	29.97	110	86	A	V
													V
													V
Remark	1. No other spurious found. 2. All results are PASS against Peak and Average limit line.												



2.4GHz 2400~2483.5MHz
WIFI 802.11g (Harmonic @ 3m)

WIFI Ant. 1+2	Note	Frequency (MHz)	Level (dBμV/m)	Over Limit (dB)	Limit Line (dBμV/m)	Read Level (dBμV)	Antenna Factor (dB/m)	Path Loss (dB)	Preamp Factor (dB)	Ant Pos (cm)	Table Pos (deg)	Peak Avg. (P/A)	Pol. (H/V)	
802.11g CH 01 2412MHz		4824	44.53	-29.47	74	58.06	31.25	13.76	58.54	100	0	P	H	
													H	
													H	
													H	
			4824	44.23	-29.77	74	57.76	31.25	13.76	58.54	100	0	P	V
														V
														V
802.11g CH 06 2437MHz		4874	47.08	-26.92	74	60.42	31.35	13.84	58.53	100	0	P	H	
		7311	44.8	-29.2	74	52.48	36.07	15.22	58.97	100	0	P	H	
													H	
													H	
			4874	45.16	-28.84	74	58.5	31.35	13.84	58.53	100	0	P	V
			7311	42.8	-31.2	74	50.48	36.07	15.22	58.97	100	0	P	V
														V
802.11g CH 11 2462MHz		4924	44.04	-29.96	74	57.19	31.45	13.92	58.52	100	0	P	H	
		7386	42.18	-31.82	74	49.65	36.28	15.15	58.9	100	0	P	H	
													H	
													H	
			4924	41.19	-32.81	74	54.34	31.45	13.92	58.52	100	0	P	V
			7386	42.73	-31.27	74	50.2	36.28	15.15	58.9	100	0	P	V
														V
Remark	1. No other spurious found.													
	2. All results are PASS against Peak and Average limit line.													



**2.4GHz 2400~2483.5MHz
WIFI 802.11n HT20 (Band Edge @ 3m)**

WIFI Ant. 1+2	Note	Frequency (MHz)	Level (dBμV/m)	Over Limit (dB)	Limit Line (dBμV/m)	Read Level (dBμV)	Antenna Factor (dB/m)	Path Loss (dB)	Preamp Factor (dB)	Ant Pos (cm)	Table Pos (deg)	Peak Avg. (P/A)	Pol. (H/V)	
802.11n HT20 CH 01 2412MHz		2389.275	62.97	-11.03	74	47.42	27.23	18.31	29.99	365	140	P	H	
		2390	50.53	-3.47	54	34.96	27.24	18.32	29.99	365	140	A	H	
	*	2412	112.54	-	-	96.9	27.29	18.34	29.99	365	140	P	H	
	*	2412	103.22	-	-	87.58	27.29	18.34	29.99	365	140	A	H	
													H	
														H
			2389.8	63.74	-10.26	74	48.17	27.24	18.32	29.99	124	213	P	V
			2390	50.38	-3.62	54	34.81	27.24	18.32	29.99	124	213	A	V
		*	2412	110.62	-	-	94.98	27.29	18.34	29.99	124	213	P	V
		*	2412	102.6	-	-	86.96	27.29	18.34	29.99	124	213	A	V
													V	
													V	
802.11n HT20 CH 06 2437MHz		2388.96	59.49	-14.51	74	43.94	27.23	18.31	29.99	355	139	P	H	
		2389.94	49.44	-4.56	54	33.87	27.24	18.32	29.99	355	139	A	H	
	*	2437	117.3	-	-	101.58	27.35	18.35	29.98	355	139	P	H	
	*	2437	109.18	-	-	93.46	27.35	18.35	29.98	355	139	A	H	
			2483.5	64.16	-9.84	74	48.29	27.46	18.38	29.97	355	139	P	H
			2483.83	50.66	-3.34	54	34.79	27.46	18.38	29.97	355	139	A	H
			2375.94	57.95	-16.05	74	42.44	27.2	18.3	29.99	171	213	P	V
			2389.52	47.28	-6.72	54	31.73	27.23	18.31	29.99	171	213	A	V
		*	2437	114.76	-	-	99.04	27.35	18.35	29.98	171	213	P	V
		*	2437	106.94	-	-	91.22	27.35	18.35	29.98	171	213	A	V
		2483.55	59.36	-14.64	74	43.49	27.46	18.38	29.97	171	213	P	V	
		2483.83	47.79	-6.21	54	31.92	27.46	18.38	29.97	171	213	A	V	



802.11n HT20 CH 11 2462MHz	*	2462	114.07	-	-	98.26	27.41	18.37	29.97	109	12	P	H
	*	2462	106.28	-	-	90.47	27.41	18.37	29.97	109	12	A	H
		2484.44	62.9	-11.1	74	47.03	27.46	18.38	29.97	109	12	P	H
		2483.52	50.77	-3.23	54	34.9	27.46	18.38	29.97	109	12	P	H
													H
													H
	*	2462	111.66	-	-	95.85	27.41	18.37	29.97	100	329	P	V
	*	2462	103.45	-	-	87.64	27.41	18.37	29.97	100	329	A	V
		2483.8	59.13	-14.87	74	43.26	27.46	18.38	29.97	100	329	P	V
		2483.64	49.67	-4.33	54	33.8	27.46	18.38	29.97	100	329	A	V
													V
													V
Remark	1. No other spurious found. 2. All results are PASS against Peak and Average limit line.												



**2.4GHz 2400~2483.5MHz
WIFI 802.11n HT20 (Harmonic @ 3m)**

WIFI Ant. 1+2	Note	Frequency (MHz)	Level (dBμV/m)	Over Limit (dB)	Limit Line (dBμV/m)	Read Level (dBμV)	Antenna Factor (dB/m)	Path Loss (dB)	Preamp Factor (dB)	Ant Pos (cm)	Table Pos (deg)	Peak Avg. (P/A)	Pol. (H/V)	
802.11n HT20 CH 01 2412MHz		4824	44.61	-29.39	74	58.14	31.25	13.76	58.54	100	0	P	H	
													H	
													H	
													H	
			4824	44.57	-29.43	74	58.1	31.25	13.76	58.54	100	0	P	V
														V
														V
802.11n HT20 CH 06 2437MHz		4874	44.51	-29.49	74	57.85	31.35	13.84	58.53	100	0	P	H	
		7311	43.65	-30.35	74	51.33	36.07	15.22	58.97	100	0	P	H	
													H	
													H	
			4874	42.69	-31.31	74	56.03	31.35	13.84	58.53	100	0	P	V
			7311	43.08	-30.92	74	50.76	36.07	15.22	58.97	100	0	P	V
														V
802.11n HT20 CH 11 2462MHz		4924	43.24	-30.76	74	56.39	31.45	13.92	58.52	100	0	P	H	
		7386	43.3	-30.7	74	50.77	36.28	15.15	58.9	100	0	P	H	
													H	
													H	
			4924	41.33	-32.67	74	54.48	31.45	13.92	58.52	100	0	P	V
			7386	43.64	-30.36	74	51.11	36.28	15.15	58.9	100	0	P	V
														V
Remark	1. No other spurious found.													
	2. All results are PASS against Peak and Average limit line.													



**2.4GHz 2400~2483.5MHz
WIFI 802.11n HT40 (Band Edge @ 3m)**

WIFI Ant. 1+2	Note	Frequency (MHz)	Level (dBμV/m)	Over Limit (dB)	Limit Line (dBμV/m)	Read Level (dBμV)	Antenna Factor (dB/m)	Path Loss (dB)	Preamp Factor (dB)	Ant Pos (cm)	Table Pos (deg)	Peak Avg. (P/A)	Pol. (H/V)
802.11n HT40 CH 03 2422MHz		2389.94	60.63	-13.37	74	45.06	27.24	18.32	29.99	143	16	P	H
		2389.52	50.69	-3.31	54	35.14	27.23	18.31	29.99	143	16	A	H
	*	2422	110.16	-	-	94.49	27.31	18.34	29.98	143	16	P	H
	*	2422	102.81	-	-	87.14	27.31	18.34	29.98	143	16	A	H
		2484.11	57.97	-16.03	74	42.1	27.46	18.38	29.97	143	16	P	H
		2485.86	47.24	-6.76	54	31.36	27.47	18.38	29.97	143	16	A	H
		2389.94	58.57	-15.43	74	43	27.24	18.32	29.99	100	312	P	V
		2389.66	49.21	-4.79	54	33.64	27.24	18.32	29.99	100	312	A	V
	*	2422	107.32	-	-	91.65	27.31	18.34	29.98	100	312	P	V
	*	2422	99.28	-	-	83.61	27.31	18.34	29.98	100	312	A	V
		2490.34	56.73	-17.27	74	40.84	27.48	18.38	29.97	100	312	P	V
		2484.39	46.9	-7.1	54	31.03	27.46	18.38	29.97	100	312	A	V
802.11n HT40 CH 06 2437MHz		2389.94	58.24	-15.76	74	42.67	27.24	18.32	29.99	278	317	P	H
		2389.66	49.73	-4.27	54	34.16	27.24	18.32	29.99	278	317	A	H
	*	2437	112.75	-	-	97.03	27.35	18.35	29.98	278	317	P	H
	*	2437	104.77	-	-	89.05	27.35	18.35	29.98	278	317	A	H
		2484.11	60.12	-13.88	74	44.25	27.46	18.38	29.97	278	317	P	H
		2483.62	50.55	-3.45	54	34.68	27.46	18.38	29.97	278	317	A	H
		2389.38	58.39	-15.61	74	42.84	27.23	18.31	29.99	100	277	P	V
		2389.94	49.15	-4.85	54	33.58	27.24	18.32	29.99	100	277	A	V
	*	2437	111.33	-	-	95.61	27.35	18.35	29.98	100	277	P	V
	*	2437	103.05	-	-	87.33	27.35	18.35	29.98	100	277	A	V
		2485.23	57.69	-16.31	74	41.82	27.46	18.38	29.97	100	277	P	V
		2483.9	48.78	-5.22	54	32.91	27.46	18.38	29.97	100	277	A	V



802.11n HT40 CH 09 2452MHz		2312.1	56.96	-17.04	74	41.73	27.05	18.2	30.02	302	310	P	H
		2388.68	46.3	-7.7	54	30.75	27.23	18.31	29.99	302	310	A	H
	*	2452	110.23	-	-	94.46	27.38	18.36	29.97	302	310	P	H
	*	2452	102.1	-	-	86.33	27.38	18.36	29.97	302	310	A	H
		2484.39	59.66	-14.34	74	43.79	27.46	18.38	29.97	302	310	P	H
		2483.76	50.42	-3.58	54	34.55	27.46	18.38	29.97	302	310	A	H
		2389.1	55.82	-18.18	74	40.27	27.23	18.31	29.99	100	261	P	V
		2388.82	46.42	-7.58	54	30.87	27.23	18.31	29.99	100	261	A	V
	*	2452	105.71	-	-	89.94	27.38	18.36	29.97	100	261	P	V
	*	2452	98.03	-	-	82.26	27.38	18.36	29.97	100	261	A	V
		2484.25	57.21	-16.79	74	41.34	27.46	18.38	29.97	100	261	P	V
		2484.32	47.68	-6.32	54	31.81	27.46	18.38	29.97	100	261	A	V
Remark	1. No other spurious found. 2. All results are PASS against Peak and Average limit line.												



**2.4GHz 2400~2483.5MHz
WIFI 802.11n HT40 (Harmonic @ 3m)**

WIFI Ant. 1+2	Note	Frequency (MHz)	Level (dBμV/m)	Over Limit (dB)	Limit Line (dBμV/m)	Read Level (dBμV)	Antenna Factor (dB/m)	Path Loss (dB)	Preamp Factor (dB)	Ant Pos (cm)	Table Pos (deg)	Peak Avg. (P/A)	Pol. (H/V)
802.11n HT40 CH 03 2422MHz		4844	40.87	-33.13	74	54.32	31.29	13.79	58.53	100	0	P	H
		7266	42.46	-31.54	74	50.27	35.94	15.26	59.01	100	0	P	H
													H
													H
		4844	40.37	-33.63	74	53.82	31.29	13.79	58.53	100	0	P	V
		7266	42.91	-31.09	74	50.72	35.94	15.26	59.01	100	0	P	V
													V
802.11n HT40 CH 06 2437MHz		4874	41.93	-32.07	74	55.27	31.35	13.84	58.53	100	0	P	H
		7311	42.35	-31.65	74	50.03	36.07	15.22	58.97	100	0	P	H
													H
													H
		4874	40.32	-33.68	74	53.66	31.35	13.84	58.53	100	0	P	V
		7311	42.87	-31.13	74	50.55	36.07	15.22	58.97	100	0	P	V
													V
802.11n HT40 CH 09 2452MHz		4904	39.63	-34.37	74	52.85	31.41	13.89	58.52	100	0	P	H
		7356	43.3	-30.7	74	50.85	36.2	15.18	58.93	100	0	P	H
													H
													H
		4904	38.86	-35.14	74	52.08	31.41	13.89	58.52	100	0	P	V
		7356	43.43	-30.57	74	50.98	36.2	15.18	58.93	100	0	P	V
													V
Remark	1. No other spurious found.												
	2. All results are PASS against Peak and Average limit line.												



2.4GHz 2400~2483.5MHz
Emission below 1GHz
2.4GHz WIFI 802.11g (LF)

WIFI Ant. 1+2	Note	Frequency (MHz)	Level (dBμV/m)	Over Limit (dB)	Limit Line (dBμV/m)	Read Level (dBμV)	Antenna Factor (dB/m)	Path Loss (dB)	Preamp Factor (dB)	Ant Pos (cm)	Table Pos (deg)	Peak Avg. (P/A)	Pol. (H/V)	
2.4GHz 802.11g LF		124.23	23.36	-20.14	43.5	36.67	17.82	1.24	32.37	-	-	P	H	
		180.66	25.08	-18.42	43.5	40.39	15.4	1.64	32.35	-	-	P	H	
		213.6	28.35	-15.15	43.5	42.51	16.3	1.9	32.36	-	-	P	H	
		320.3	28.63	-17.37	46	38.13	20.31	2.63	32.44	-	-	P	H	
		890.8	31.96	-14.04	46	30.21	28.94	4.65	31.84	-	-	P	H	
		948.2	32.6	-13.4	46	29.28	30.08	4.61	31.37	100	0	P	H	
														H
														H
														H
														H
														H
														H
			39.45	28.59	-11.41	40	40.17	20.4	0.46	32.44	100	0	P	V
			179.04	28.21	-15.29	43.5	43.47	15.46	1.63	32.35	-	-	P	V
			213.6	26.28	-17.22	43.5	40.44	16.3	1.9	32.36	-	-	P	V
			320.3	29.89	-16.11	46	39.39	20.31	2.63	32.44	-	-	P	V
			427.4	34.34	-11.66	46	40.72	22.95	3.19	32.52	-	-	P	V
			939.1	32.23	-13.77	46	29.2	29.86	4.62	31.45	-	-	P	V
														V
														V
													V	
													V	
													V	
													V	
													V	
Remark	1. No other spurious found. 2. All results are PASS against limit line.													



Note symbol

*	Fundamental Frequency which can be ignored. However, the level of any unwanted emissions shall not exceed the level of the fundamental frequency.
!	Test result is over limit line.
P/A	Peak or Average
H/V	Horizontal or Vertical



A calculation example for radiated spurious emission is shown as below:

WIFI	Note	Frequency	Level	Over	Limit	Read	Antenna	Path	Preamp	Ant	Table	Peak	Pol.
Ant.				Limit	Line	Level	Factor	Loss	Factor	Pos	Pos	Avg.	
1		(MHz)	(dBμV/m)	(dB)	(dBμV/m)	(dBμV)	(dB/m)	(dB)	(dB)	(cm)	(deg)	(P/A)	(H/V)
802.11b		2390	55.45	-18.55	74	54.51	32.22	4.58	35.86	103	308	P	H
CH 01													
2412MHz		2390	43.54	-10.46	54	42.6	32.22	4.58	35.86	103	308	A	H

1. Path Loss(dB) = Cable loss(dB) + Filter loss(dB) + Attenuator loss(dB)
2. Level(dBμV/m) =
Antenna Factor(dB/m) + Path Loss(dB) + Read Level(dBμV) - Preamp Factor(dB)
3. Over Limit(dB) = Level(dBμV/m) – Limit Line(dBμV/m)

For Peak Limit @ 2390MHz:

1. Level(dBμV/m)
= Antenna Factor(dB/m) + Path Loss(dB) + Read Level(dBμV) - Preamp Factor(dB)
= 32.22(dB/m) + 4.58(dB) + 54.51(dBμV) – 35.86 (dB)
= 55.45 (dBμV/m)
2. Over Limit(dB)
= Level(dBμV/m) – Limit Line(dBμV/m)
= 55.45(dBμV/m) – 74(dBμV/m)
= -18.55(dB)

For Average Limit @ 2390MHz:

1. Level(dBμV/m)
= Antenna Factor(dB/m) + Path Loss(dB) + Read Level(dBμV) - Preamp Factor(dB)
= 32.22(dB/m) + 4.58(dB) + 42.6(dBμV) – 35.86 (dB)
= 43.54 (dBμV/m)
2. Over Limit(dB)
= Level(dBμV/m) – Limit Line(dBμV/m)
= 43.54(dBμV/m) – 54(dBμV/m)
= -10.46(dB)

Both peak and average measured complies with the limit line, so test result is “PASS”.



Appendix C. Radiated Spurious Emission Plots

Test Engineer :	Jacky Hung, CR Liao, and Andy Yang	Temperature :	23~25°C
		Relative Humidity :	55~57%

Note symbol

-L	Low channel location
-R	High channel location



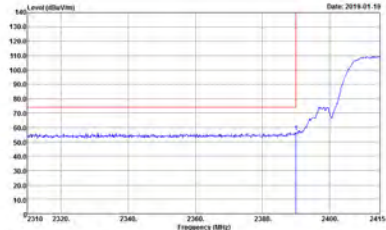
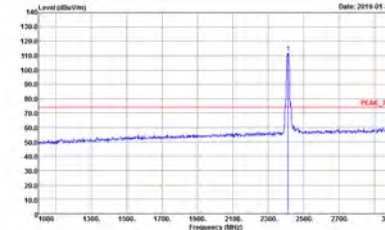
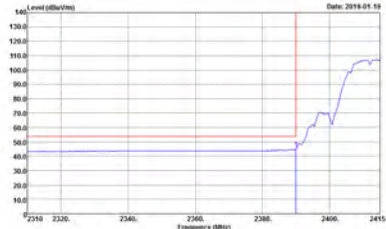
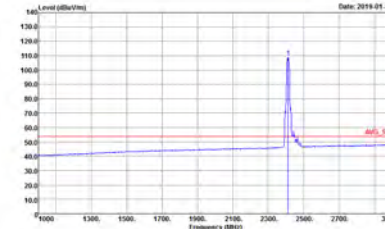

2.4GHz 2400~2483.5MHz
WIFI 802.11b (Band Edge @ 3m)

WIFI	2.4GHz 2400~2483.5MHz Band Edge @ 3m	
ANT	802.11b CH01 2412MHz	
1	Horizontal	Fundamental
Peak	 <p>Site : 03CH16-HY Condition : PEAK_BE_74 3m 91200_1522 HORIZONTAL Detector : Peak Project : 910212 Setting : 20.5</p>	 <p>Site : 03CH16-HY Condition : PEAK_74 3m 91200_1522 HORIZONTAL Detector : Peak Project : 910212 Setting : 20.5</p>
Avg.	 <p>Site : 03CH16-HY Condition : AVG_BE_54 3m 91200_1522 HORIZONTAL Detector : Peak Project : 910212 Setting : 20.5</p>	 <p>Site : 03CH16-HY Condition : AVG_54 3m 91200_1522 HORIZONTAL Detector : Peak Project : 910212 Setting : 20.5</p>

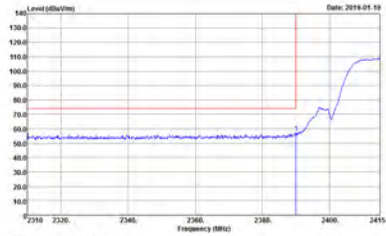
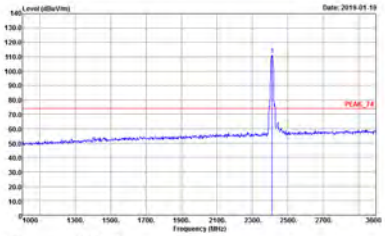
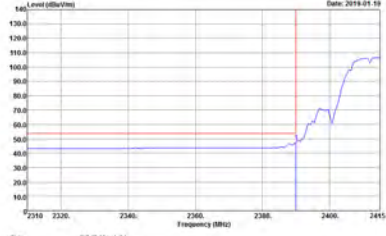
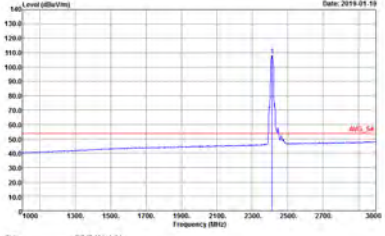

WIFI	2.4GHz 2400~2483.5MHz Band Edge @ 3m	
ANT	802.11b CH01 2412MHz	
1	Vertical	Fundamental
Peak	 <p>Site : 03CH16-HY Condition : PEAK_BE_74 3m 91200_1522 VERTICAL RBW:3000.0000Hz VSW:3000.0000Hz SWT:Auto Detector : Peak Project : 910212 Setting : 20.5</p>	 <p>Site : 03CH16-HY Condition : PEAK_74 3m 91200_1522 VERTICAL RBW:3000.0000Hz VSW:3000.0000Hz SWT:Auto Detector : Peak Project : 910212 Setting : 20.5</p>
Avg.	 <p>Site : 03CH16-HY Condition : AVG_BE_54 3m 91200_1522 VERTICAL RBW:3000.0000Hz VSW:0.0100Hz SWT:Auto Detector : Peak Project : 910212 Setting : 20.5</p>	 <p>Site : 03CH16-HY Condition : AVG_54 3m 91200_1522 VERTICAL RBW:3000.0000Hz VSW:0.0100Hz SWT:Auto Detector : Peak Project : 910212 Setting : 20.5</p>

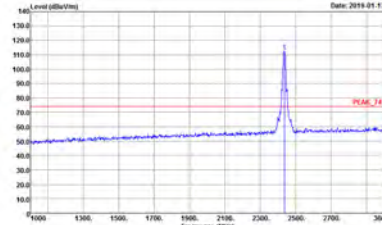

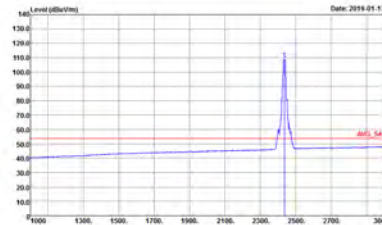
WIFI	2.4GHz 2400~2483.5MHz Band Edge @ 3m	
ANT	802.11b CH06 2437MHz - L	
1	Horizontal	Fundamental
Peak	 <p>Site : 03CH16-HY Condition : PEAK_BE_74 3m 91200_1522 HORIZONTAL Detector : Peak Project : 910212 Setting : Z2</p>	 <p>Site : 03CH16-HY Condition : PEAK_74 3m 91200_1522 HORIZONTAL Detector : Peak Project : 910212 Setting : Z2</p>
Avg.	 <p>Site : 03CH16-HY Condition : AVG_BE_54 3m 91200_1522 HORIZONTAL Detector : Peak Project : 910212 Setting : Z2</p>	 <p>Site : 03CH16-HY Condition : AVG_54 3m 91200_1522 HORIZONTAL Detector : Peak Project : 910212 Setting : Z2</p>

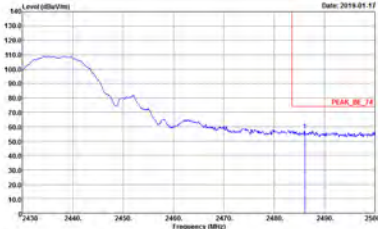
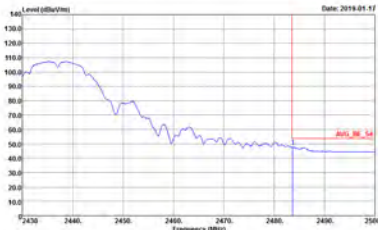

WIFI	2.4GHz 2400~2483.5MHz Band Edge @ 3m	
ANT	802.11b CH06 2437MHz - R	
1	Horizontal	Fundamental
Peak	 <p>Site : 03CH16-HY Condition : PEAK_BE_74 3m 91200_1522 HORIZONTAL RBW:3000.0000Hz VBW:3000.0000Hz SWT:Auto Detector : Peak Project : 910212 Setting : Z2</p>	Left blank
Avg.	 <p>Site : 03CH16-HY Condition : Avg_BE_54 3m 91200_1522 HORIZONTAL RBW:3000.0000Hz VBW:3000.0000Hz SWT:Auto Detector : Peak Project : 910212 Setting : Z2</p>	Left blank



WIFI	2.4GHz 2400~2483.5MHz Band Edge @ 3m	
ANT	802.11b CH06 2437MHz - L	
1	Vertical	Fundamental
Peak	<p>Site : 03CH16-HY Condition : PEAK_BE_74 3m 91200_1522 VERTICAL Detector : Peak Project : 910212 Setting : Z2</p>	<p>Site : 03CH16-HY Condition : PEAK_74 3m 91200_1522 VERTICAL Detector : Peak Project : 910212 Setting : Z2</p>
Avg.	<p>Site : 03CH16-HY Condition : AVG_BE_54 3m 91200_1522 VERTICAL Detector : Peak Project : 910212 Setting : Z2</p>	<p>Site : 03CH16-HY Condition : AVG_54 3m 91200_1522 VERTICAL Detector : Peak Project : 910212 Setting : Z2</p>

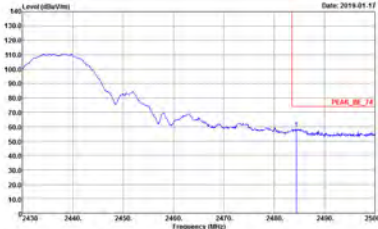
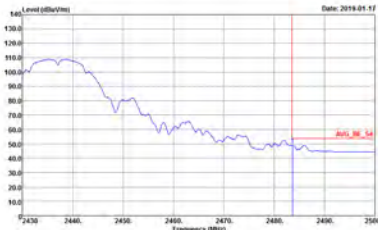

WIFI	2.4GHz 2400~2483.5MHz Band Edge @ 3m	
ANT	802.11b CH06 2437MHz - R	
1	Vertical	Fundamental
Peak	 <p>Site : 03CH16-HY Condition : /PEAK_BE_74 3m 91200_1522 VERTICAL RBW:3000.0000Hz VSW:3000.0000Hz SWT:Auto Detector : Peak Project : 910212 Setting : Z2</p>	Left blank
Avg.	 <p>Site : 03CH16-HY Condition : /AVG_BE_54 3m 91200_1522 VERTICAL RBW:3000.0000Hz VSW:3.0000Hz SWT:Auto Detector : Peak Project : 910212 Setting : Z2</p>	Left blank

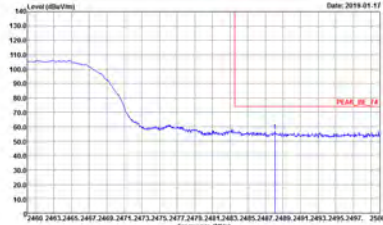
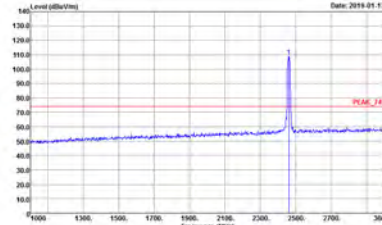
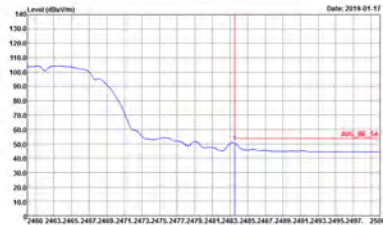
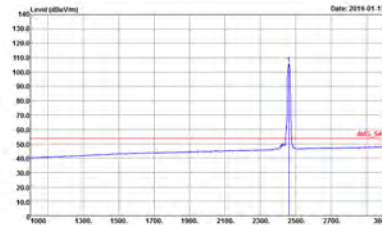

WIFI	2.4GHz 2400~2483.5MHz Band Edge @ 3m	
ANT	802.11b CH11 2462MHz	
1	Horizontal	Fundamental
Peak	 <p>Site : 03CH16-HY Condition : PEAK_BE_74 3m 91200_1522 HORIZONTAL RBW:3000.0000Hz VSW:3000.0000Hz SWT:Auto Detector : Peak Project : 910212 Setting : 18.125</p>	 <p>Site : 03CH16-HY Condition : PEAK_74 3m 91200_1522 HORIZONTAL RBW:3000.0000Hz VSW:3000.0000Hz SWT:Auto Detector : Peak Project : 910212 Setting : 18.125</p>
Avg.	 <p>Site : 03CH16-HY Condition : AVG_BE_54 3m 91200_1522 HORIZONTAL RBW:3000.0000Hz VSW:0.0100Hz SWT:Auto Detector : Peak Project : 910212 Setting : 18.125</p>	 <p>Site : 03CH16-HY Condition : AVG_54 3m 91200_1522 HORIZONTAL RBW:3000.0000Hz VSW:0.0100Hz SWT:Auto Detector : Peak Project : 910212 Setting : 18.125</p>

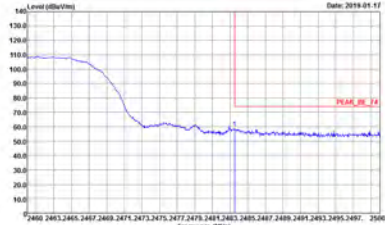
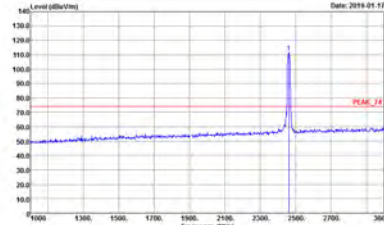
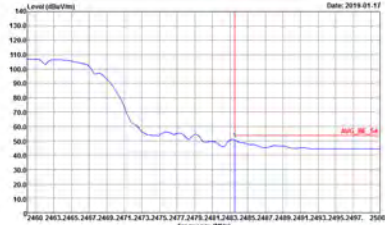
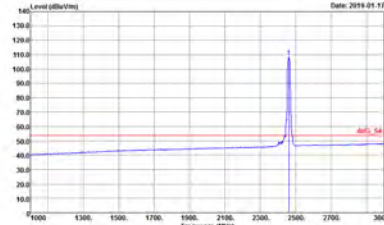

WIFI	2.4GHz 2400~2483.5MHz Band Edge @ 3m	
ANT	802.11b CH11 2462MHz	
1	Vertical	Fundamental
Peak	 <p>Site : 03CH16-HY Condition : PEAK_BE_74 3m 91200_1522 VERTICAL RBW:3000.0000Hz VSW:3000.0000Hz SWT:Auto Detector : Peak Project : 910212 Setting : 18.125</p>	 <p>Site : 03CH16-HY Condition : PEAK_74 3m 91200_1522 VERTICAL RBW:3000.0000Hz VSW:3000.0000Hz SWT:Auto Detector : Peak Project : 910212 Setting : 18.125</p>
Avg.	 <p>Site : 03CH16-HY Condition : AVG_BE_54 3m 91200_1522 VERTICAL RBW:3000.0000Hz VSW:0.0100Hz SWT:Auto Detector : Peak Project : 910212 Setting : 18.125</p>	 <p>Site : 03CH16-HY Condition : AVG_54 3m 91200_1522 VERTICAL RBW:3000.0000Hz VSW:0.0100Hz SWT:Auto Detector : Peak Project : 910212 Setting : 18.125</p>

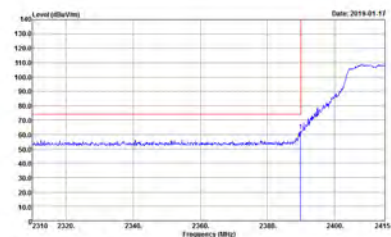
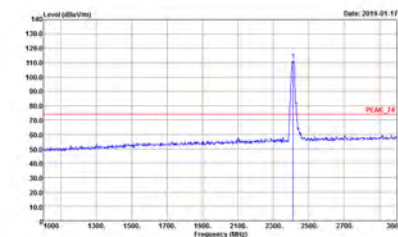
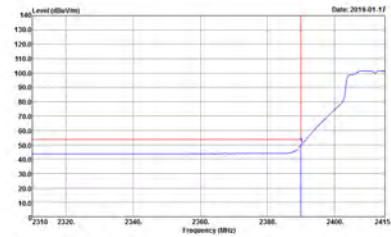
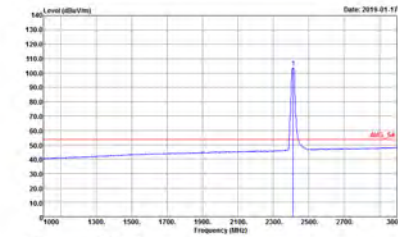

2.4GHz 2400~2483.5MHz
WIFI 802.11g (Band Edge @ 3m)

WIFI	2.4GHz 2400~2483.5MHz Band Edge @ 3m	
ANT	802.11g CH01 2412MHz	
1	Horizontal	Fundamental
Peak	 <p>Site : 03CH16-HY Condition : PEAK_BE_74 3m 91200_1522 HORIZONTAL Detector : Peak Project : 910212 Setting : 17.875</p>	 <p>Site : 03CH16-HY Condition : PEAK_74 3m 91200_1522 HORIZONTAL Detector : Peak Project : 910212 Setting : 17.875</p>
Avg.	 <p>Site : 03CH16-HY Condition : AVG_BE_54 3m 91200_1522 HORIZONTAL Detector : Peak Project : 910212 Setting : 17.875</p>	 <p>Site : 03CH16-HY Condition : AVG_54 3m 91200_1522 HORIZONTAL Detector : Peak Project : 910212 Setting : 17.875</p>

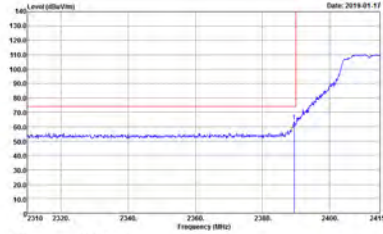
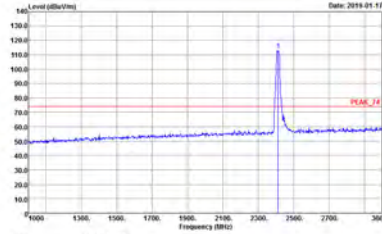
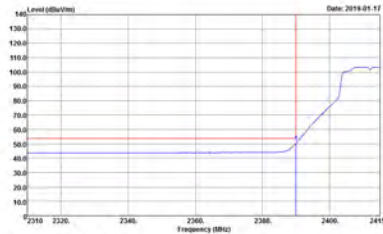
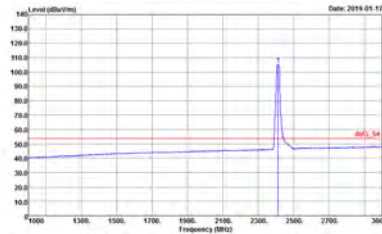

WIFI	2.4GHz 2400~2483.5MHz Band Edge @ 3m	
ANT	802.11g CH01 2412MHz	
1	Vertical	Fundamental
Peak	 <p>Site : 03CH16-HY Condition : PEAK_8E_74 3m 91200_1522 VERTICAL RBW:3000.0000Hz VSW:3000.0000Hz SWT:Auto Detector : Peak Project : 910212 Setting : 17.875</p>	 <p>Site : 03CH16-HY Condition : PEAK_74 3m 91200_1522 VERTICAL RBW:3000.0000Hz VSW:3000.0000Hz SWT:Auto Detector : Peak Project : 910212 Setting : 17.875</p>
Avg.	 <p>Site : 03CH16-HY Condition : AVG_8E_54 3m 91200_1522 VERTICAL RBW:3000.0000Hz VSW:0.0100Hz SWT:Auto Detector : Peak Project : 910212 Setting : 17.875</p>	 <p>Site : 03CH16-HY Condition : AVG_54 3m 91200_1522 VERTICAL RBW:3000.0000Hz VSW:0.0100Hz SWT:Auto Detector : Peak Project : 910212 Setting : 17.875</p>

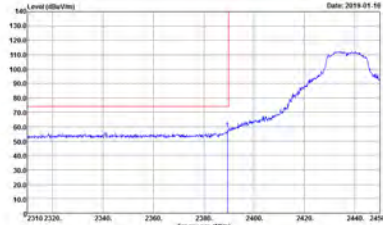
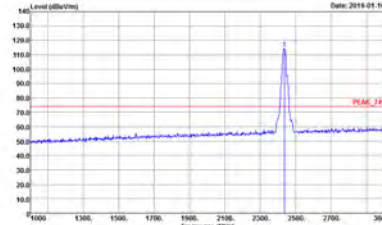
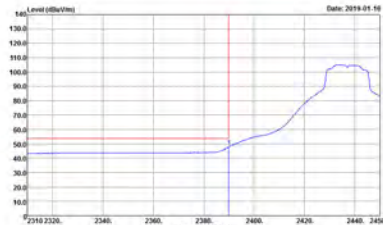
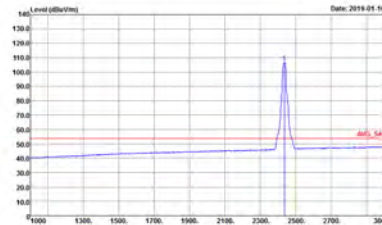

WIFI	2.4GHz 2400~2483.5MHz Band Edge @ 3m	
ANT	802.11g CH06 2437MHz - L	
1	Horizontal	Fundamental
Peak	 <p>Site : 03CH16-HY Condition : PEAK_BE_74 3m 91200_1522 HORIZONTAL RBW:3000.0000Hz VSW:3000.0000Hz SWT:Auto Detector : Peak Project : 910212 Setting : Z1.625</p>	 <p>Site : 03CH16-HY Condition : PEAK_74 3m 91200_1522 HORIZONTAL RBW:3000.0000Hz VSW:3000.0000Hz SWT:Auto Detector : Peak Project : 910212 Setting : Z1.625</p>
Avg.	 <p>Site : 03CH16-HY Condition : AVG_BE_54 3m 91200_1522 HORIZONTAL RBW:3000.0000Hz VSW:0.0100Hz SWT:Auto Detector : Peak Project : 910212 Setting : Z1.625</p>	 <p>Site : 03CH16-HY Condition : AVG_54 3m 91200_1522 HORIZONTAL RBW:3000.0000Hz VSW:0.0100Hz SWT:Auto Detector : Peak Project : 910212 Setting : Z1.625</p>

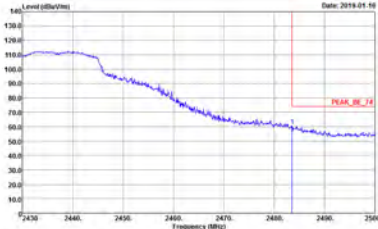
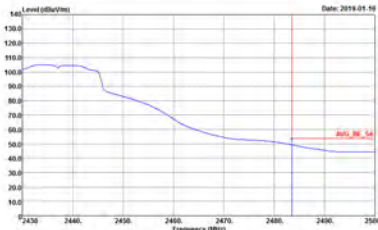

WIFI	2.4GHz 2400~2483.5MHz Band Edge @ 3m	
ANT	802.11g CH06 2437MHz - R	
1	Horizontal	Fundamental
Peak	 <p>Site : 03CH16-HY Condition : PEAK_BE_74 3m 91200_1522 HORIZONTAL RBW:3000.0000Hz VSW:3000.0000Hz SWT:Auto Detector : Peak Project : 910212 Setting : Z1.625</p>	Left blank
Avg.	 <p>Site : 03CH16-HY Condition : AVG_BE_54 3m 91200_1522 HORIZONTAL RBW:3000.0000Hz VSW:3000.0000Hz SWT:Auto Detector : Peak Project : 910212 Setting : Z1.625</p>	Left blank

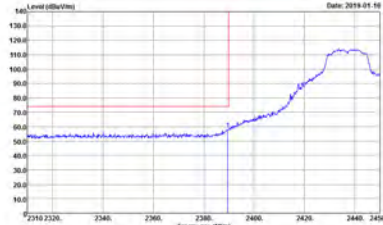
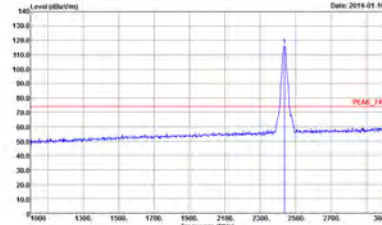
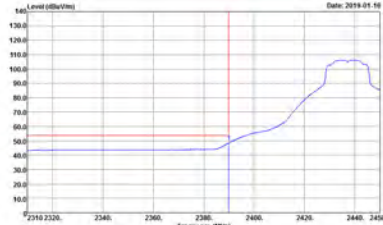
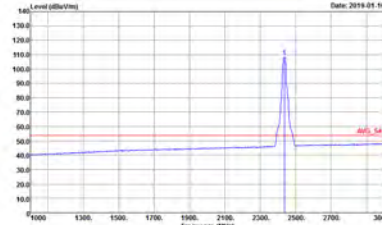

WIFI	2.4GHz 2400~2483.5MHz Band Edge @ 3m	
ANT	802.11g CH06 2437MHz - L	
1	Vertical	Fundamental
Peak	 <p>Site : 03CH16-HY Condition : PEAK_BE_74 3m 91200_1522 VERTICAL RBW:3000.0000Hz VSW:3000.0000Hz SWT:Auto Detector : Peak Project : 910212 Setting : Z1.625</p>	 <p>Site : 03CH16-HY Condition : PEAK_74 3m 91200_1522 VERTICAL RBW:3000.0000Hz VSW:3000.0000Hz SWT:Auto Detector : Peak Project : 910212 Setting : Z1.625</p>
Avg.	 <p>Site : 03CH16-HY Condition : AVG_BE_54 3m 91200_1522 VERTICAL RBW:3000.0000Hz VSW:0.0100Hz SWT:Auto Detector : Peak Project : 910212 Setting : Z1.625</p>	 <p>Site : 03CH16-HY Condition : AVG_54 3m 91200_1522 VERTICAL RBW:3000.0000Hz VSW:0.0100Hz SWT:Auto Detector : Peak Project : 910212 Setting : Z1.625</p>