

# Inari 10 Quick Start Guide

## Inari features, buttons & interfaces

### Front

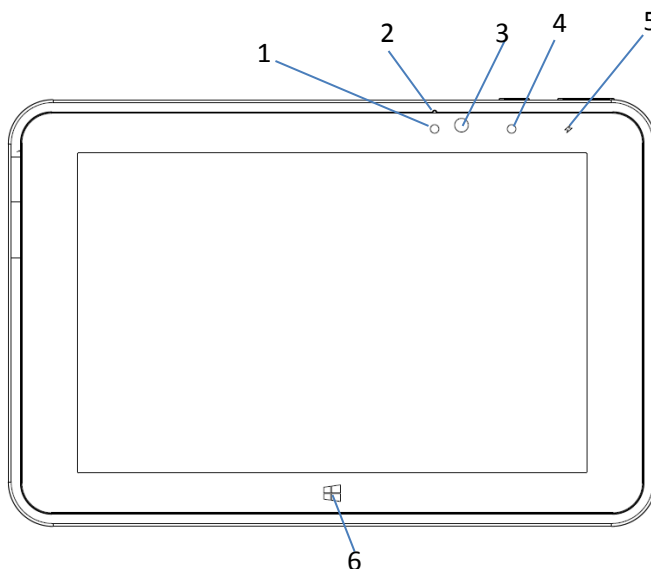

- |          |   |
|----------|---|
| <b>1</b> | <b>Ambient Light Sensor</b><br>Recognizes the ambient light and adjusts the display brightness if enabled in the operating system         |
| <b>2</b> | <b>Front microphone outlet</b>  |
| <b>3</b> | <b>Front camera</b><br>2MP camera for video conferencing  |
| <b>4</b> | <b>Camera Indicator LED</b><br>Lights up if camera is activated and during device boot and shutdown                                       |
| <b>5</b> | <b>Charging indicator LED</b><br>OFF not connected to charger<br>ORANGE charging<br>GREEN connected and fully charged<br>RED charge fault |
| <b>6</b> | <b>Windows Button</b><br>Touch it to return to the start menu   |

## Top side

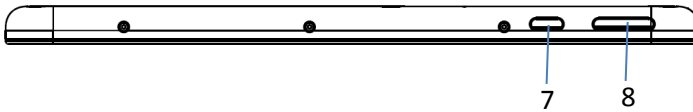

### 7 On / Off Button

Push it once to start the tablet; push it again to enable the sleep mode. Push and hold it to shut down the device.

### 8 Volume key

Push the left side to reduce the volume, use the right side to increase the volume

## Right and Bottom side

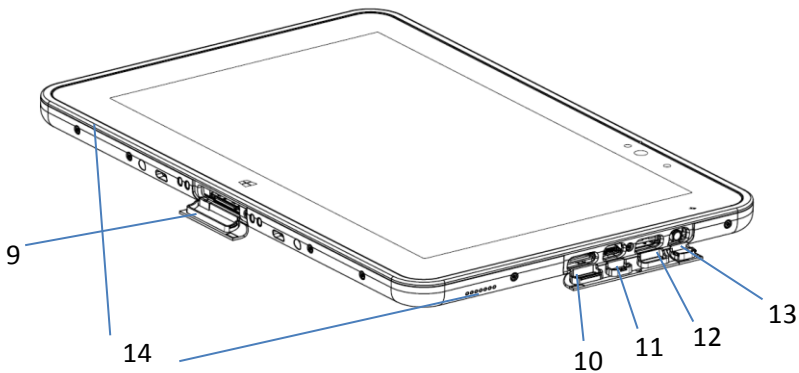

### 9 Docking connector

### 10 MicroSDXC card slot

### 11 MicroUSB interface

*For charging only!*

### 12 USB 2.0 port

### 13 Audio jack

combined microphone & speaker connector

### 14 Stereo speakers (on the sides)

## Rear view

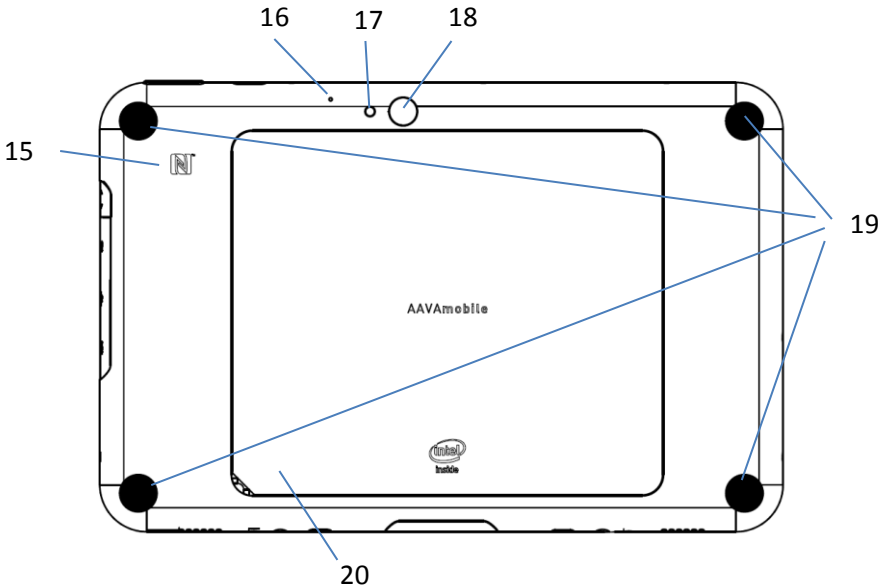

- |           |  |
|-----------|--|
| <b>15</b> | NFC antenna position<br>Can be used to read NFC & RFID tags  |
| <b>16</b> | Rear microphone outlet                                       |
| <b>17</b> | Camera flash LED   |
| <b>18</b> | Rear camera<br>8MP camera for high resolution images & video |
| <b>19</b> | Mechanical fixing points behind covers                       |
| <b>20</b> | Battery lid  |

## Replacing Battery / Adding SIM card

To replace the battery, take of the battery lid by pulling on the lid carefully. Pull on the battery holder hook (1) to the bottom of the device. Pull the battery up (2), and pull on the second battery holder hook (3).

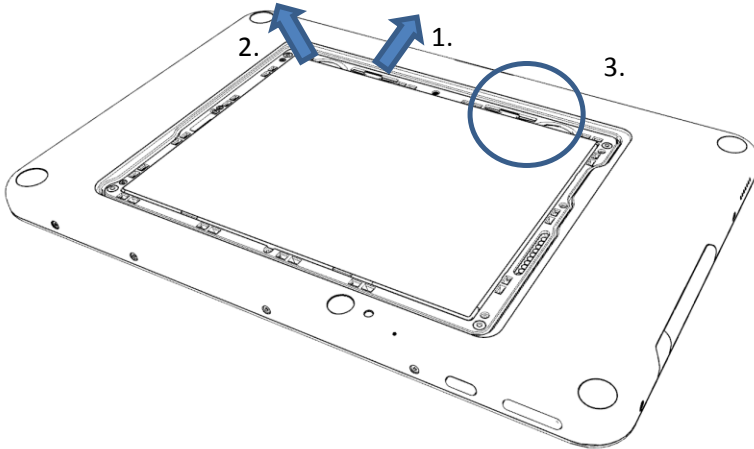

Enter the SIM card into the slot in the bottom right corner. Please make sure you have the SIM card in the correct direction (chip facing down).

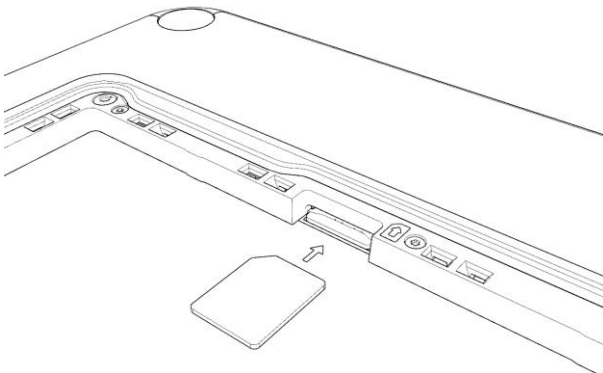

When putting the battery back in place, please make sure you use an angle of max. 30° against the tablet back and that both hooks have clicked and are safely secured.



## Using the Tablet for the first time

1. Connect power supply for the first time and make sure battery is fully charged before disconnecting.

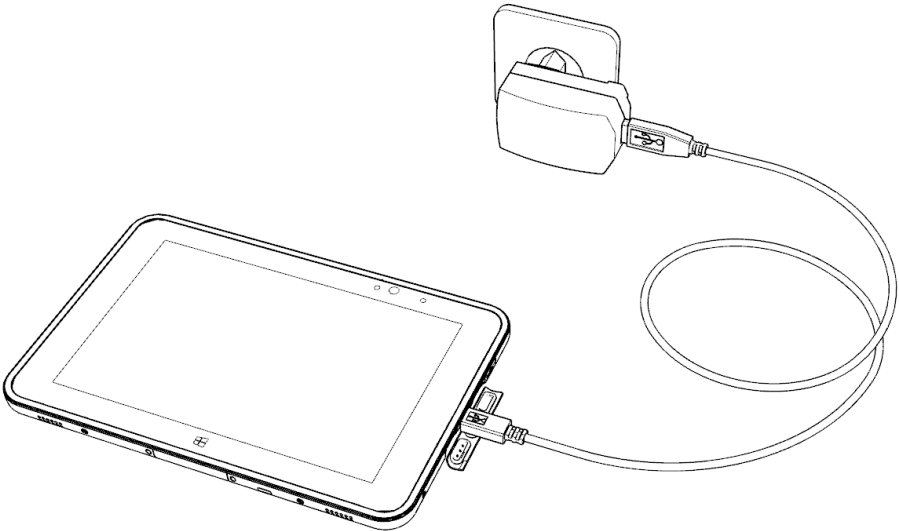

2. Press the power button

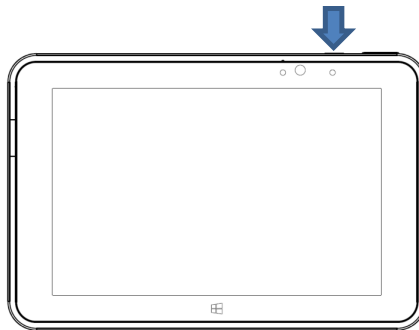

3. Follow the instructions in the operating system to complete the setup

## Troubleshooting

In case devices freezes and you need to do a hard reset, press and hold the power button for approx. 14 seconds. Device will be turned off now.

## Important Product and Safety information

- Do not drop, bend or twist your tablet. This can break tablet display glass, internal circuit boards or mechanics. If the glass breaks, do not touch the glass parts of the device or attempt to remove the broken glass from the device. Stop using the device until the glass is replaced by qualified service personnel.
- Do not try to disassembly your tablet. This may damage the device.
- Operate your device in a place where temperature is between -10°C and +50°C.
- Charge your device with the supplied charger in a place where temperature is between 0°C and +40°C.
- Store your device in a place where temperature is between -20°C and +60°C.
- This product is intended to be supplied by a Listed Direct Plug-In Power Unit marked "Class 2" or LPS and rated 5 V DC, 2A
- For charging the socket-outlet shall be installed near the equipment and shall be easily accessible.
- Protect your device from water and moisture intake. Keep connector doors closed when not in use to prevent water and moisture intake.
- Listen to a headset at a moderate level, and do not place the device loudspeaker outlets near your ear when the loudspeakers are in use.
- Use only soft, clean and dry lint-free cloth to clean your device.
- Keep the unit and accessories away from small children.
- Switch off your device before boarding to an aircraft.
- Switch off your device in any area with a potentially explosive atmosphere.
- Your device meets guidelines for exposure to radio waves (SAR, Specific Absorption Rate).
- **Use only charger delivered with your tablet.**
- **Power rating: 3.8V  $\overline{\text{---}}$  3.0A**
- Do not disconnect charger by pulling the cord.
- Do not use damaged power cords or plugs.
- Do not use Nano-to-Micro SIM card adapters.
- **Save energy.** You can save energy by doing following.
  - Close unused applications and data connections.
  - Decrease screen brightness and sound volume.
  - Deactivate unnecessary sounds like touch panel sound.
  - Disconnect your charger from mains outlet when charger is not needed.
  - Do no keep unnecessary accessories connected in your device.
- **Recycle.** Return your used electronic units to dedicated collection points. Please note that your tablet has a battery, so it is not allowed to be disposed to normal household waste and battery requires separate recycling.
- **Replaceable battery safety**
  - Batteries have life cycles. If the time that the battery powers equipment becomes much shorter than usual, the battery life might be at the end.
  - Fully charge the battery at least every 6 months.
  - Stop using the tablet if abnormal heat, order, discoloration, deformation, or abnormal condition is detected during use, charge, or storage.
  - Keep the device away from heat (battery temperature not to exceed 60°C).
  - Do not throw battery into fire, it may be exploded.
  - Do not soak the battery with liquid like water, tea, coffee etc.
  - Do not hit, bend, deform or drop the battery.
  - Do not pierce battery with a sharp object such as a needle, etc.
  - The battery should not have liquid from electrolyte flowing, but in case the electrolyte come into contact with eyes, don't rub your eyes. Wash your eyes well with clean water and go to see a doctor immediately. In case the electrolyte come into contact with your skin, wash it well with clean water.
  - Do not externally short-circuit the battery. If externally short-circuited, the battery may be heated, ignited or broken.
  - There is a risk of explosion if you replace the battery with an incorrect type. Only use the correct battery type for this device.
  - Dispose of battery needs to be done according to instructions above.

## Warning Statements

To prevent possible hearing damage, do not listen at high volume levels for long periods.



## Antenna positions

Your device meets guidelines for exposure to radio waves (SAR, Specific Absorption Rate).  
Antenna areas are highlighted in below pictures.

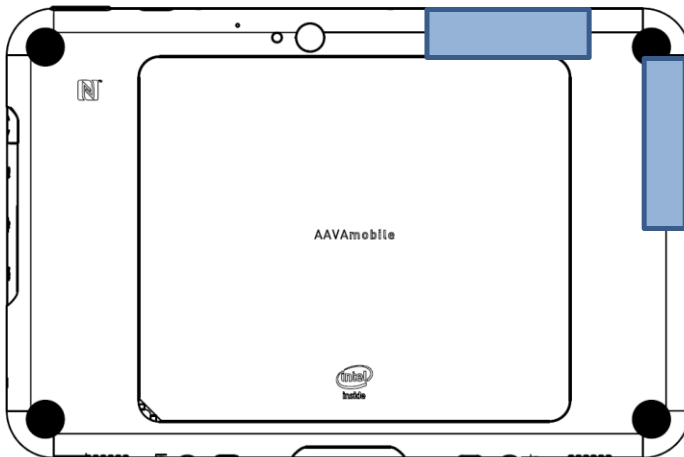
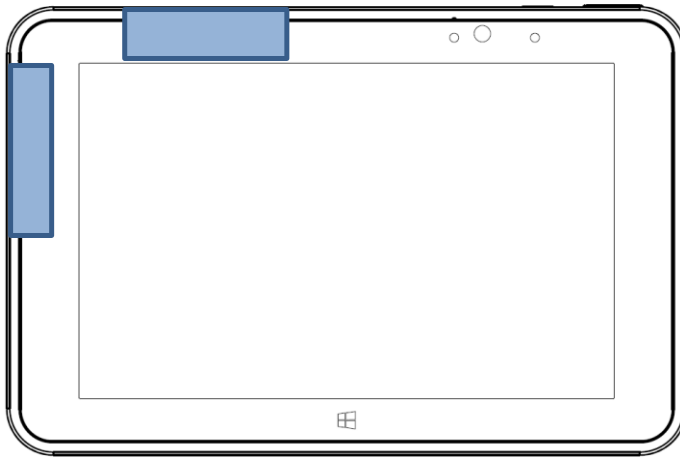

## Conformity Declarations

Depending on the actual model, following conformity / compliance statements are valid. Please check the type label of your device for further information.

### EU Declaration of Conformity

Hereby, Aava Mobile declares that this device is in compliance with the essential requirements and other relevant provisions of Directive 1999/5/EC.



### FCC Compliance Statement

15.21

You are cautioned that changes or modifications not expressly approved by the part responsible for compliance could void the user's authority to operate the equipment.

15.105(b)

This equipment has been tested and found to comply with the limits for a Class B digital device, pursuant to part 15 of the FCC rules. These limits are designed to provide reasonable protection against harmful interference in a residential installation. This equipment generates, uses and can radiate radio frequency energy and, if not installed and used in accordance with the instructions, may cause harmful interference to radio communications. However, there is no guarantee that interference will not occur in a particular installation. If this equipment does cause harmful interference to radio or television reception, which can be determined by turning the equipment off and on, the user is encouraged to try to correct the interference by one or more of the following measures:

- Reorient or relocate the receiving antenna.
- Increase the separation between the equipment and receiver.
- Connect the equipment into an outlet on a circuit different from that to which the receiver is connected.
- Consult the dealer or an experienced radio/TV technician for help.

**This device complies with Part 15 of the FCC Rules. Operation is subject to the following two conditions:**

1. this device may not cause harmful interference and
2. this device must accept any interference received, including interference that may cause undesired operation of the device.
- 3.

**FCC type approval ID:** 2ABVH-INARI101, 2ABVH-INARI102

### RF Exposure Information (SAR)

This model device meets the government's requirements for exposure to radio waves. This device is designed and manufactured not to exceed the emission limits for exposure to radio frequency (RF) energy set by the Federal Communications Commission of the U. S. Government. The exposure standard for wireless devices employs a unit of measurement known as the Specific Absorption Rate, or SAR. The SAR limit set by the FCC is 1.6 W/kg. Tests for SAR are conducted using standard operating positions accepted by the FCC with the device transmitting at its highest certified level, the actual SAR level of the device while operating can be well below the maximum value. This is because the device is designed to operate at multiple power levels so as to use only the power required to reach the network. In general, the closer you are to a wireless base station antenna, the lower the power output.

While there may be differences between the SAR levels of various devices and at various positions, the all meet the government requirement.

The FCC has granted an Equipment Authorization for this model device with all reported SAR levels evaluated as in compliance with the FCC RF exposure guidelines. SAR information on this model device is on file with the FCC and can be found under the Display Grant section of <http://www.fcc.gov/oet/fccid> after searching on the below:

FCC ID: 2ABVH-INARI101, 2ABVH-INARI102

Specific Absorption Rate (SAR) for 2ABVH-INARI 101: 1.150 W/kg

Specific Absorption Rate (SAR) for 2ABVH-INARI 102: 1.320 W/kg

This product has been tested and found to comply with the following standards:

- For the worst case positions, the INARI 10 is in compliance with the IEEE 1528:2103, KDB 447498 D01 and RSS-102, issue 5. SAR assessment in body worn was conducted with a distance of 0 mm between the housing of the handheld and the flat phantom.
- EM 62311:2008: Assessment of electronic and electrical equipment related to human exposure restrictions for electromagnetic fields (0 Hz – 300 GHz).



## Canadian Compliance Statement

This Class B digital apparatus complies with Canadian ICES-003.

*Cet appareil numérique de classe B est conforme à la norme NMB-003.*

**This device complies with Industry Canada licence-exempt RSS standard(s).** Operation is subject to the following two conditions: (1) this device may not cause interference, and (2) this device must accept any interference, including interference that may cause undesired operation of the device.

**Cet appareil est conforme avec Industrie Canada RSS standard exempts de licence(s).** Son fonctionnement est soumis aux deux conditions suivantes: (1) cet appareil ne peut pas provoquer d'interférences et (2) cet appareil doit accepter toute interférence, y compris les interférences pouvant entraîner un mauvais fonctionnement de la appareil.

**IC certification number:** 11875A-INARI101, 11875A-INARI102

## Radiation Exposure Statement (SAR)

Warning: This equipment complies with SAR for general population / uncontrolled exposure limits in Canada RSS-102 for exposure to radio frequency (RF) radiation.

Specific Absorption Rate (SAR) for INARI10-LTBN-1: 1.150 W/kg

Specific Absorption Rate (SAR) for INARI10-LTDN-2: 1.320 W/kg

## Énoncé sur l'exposition aux radiations (SAR)

*Avertissement : Cet équipement est conforme aux limites d'exposition au rayonnement à fréquence radioélectrique (RF) établies par la norme CNR-102 d'Industrie Canada.*

*Débit d'absorption spécifique (DAS) INARI10-LTBN-1: 1.150 W/kg*

*Débit d'absorption spécifique (DAS) INARI10-LTDN-2: 1.320 W/kg*

## 802.11a Radio Precaution Statement

- The device for operation in the band 5150-5250 MHz is only for indoor use to reduce the potential for harmful interference to co-channel mobile satellite systems;

- The maximum antenna gain permitted for devices in the bands 5250-5350 MHz and 5470-5725 MHz shall comply with the e.i.r.p. limit; and

- The maximum antenna gain permitted for devices in the band 5725-5825 MHz shall comply with the e.i.r.p. limits specified for point-to-point and non point-to-point operation as appropriate.

- Users should also be advised that high-power radars are allocated as primary users (i.e. priority users) of the bands 5250-5350 MHz and 5650-5850 MHz and that these radars could cause interference and/or damage to LE-LAN devices.

*- Les dispositifs fonctionnant dans la bande 5 150-5 250 MHz sont réservés uniquement pour une utilisation à l'intérieur afin de réduire les risques de brouillage préjudiciable aux systèmes de satellites mobiles utilisant les mêmes canaux;*

*- Le gain maximal d'antenne permis pour les dispositifs utilisant les bandes 5 250-5 350 MHz et 5 470-5 725 MHz doit se conformer à la limite de p.i.r.e.;*

*- Le gain maximal d'antenne permis (pour les dispositifs utilisant la bande 5 725-5 825 MHz) doit se conformer à la limite de p.i.r.e. spécifiée pour l'exploitation point à point et non point à point, selon le cas.*

*- De plus, les utilisateurs devraient aussi être avisés que les utilisateurs de radars de haute puissance sont désignés utilisateurs principaux (c.-à-d., qu'ils ont la priorité) pour les bandes 5 250-5 350 MHz et 5 650-5 850 MHz et que ces radars pourraient causer du brouillage et/ou des dommages aux dispositifs LAN-EL.*

## 802.11 Radio Precaution statement

Users are responsible for configuring the channels of operation that comply with their country regulatory standards.

A Wireless Network Administrator should review the operating restrictions detailed within the Access Point installation manual.





