



# TEST REPORT

**Test Report No. :** UL-RPT-RP10809253JD16E V2.0

**Manufacturer** : Aava Mobile Oy  
**Model No.** : INARI10-LTDN-2  
**FCC ID** : 2ABVH-INARI102  
**IC Certification No.** : 11875A-INARI102  
**Technology** : WLAN  
**Test Standard(s)** : FCC Parts 15.209(a) & 15.407(b)  
Industry Canada RSS-Gen 6.13 & 8.9 / RSS-247 6.2

1. This test report shall not be reproduced in full or partial, without the written approval of UL VS LTD.
2. The results in this report apply only to the sample(s) tested.
3. The sample tested is in compliance with the above standard(s).
4. The test results in this report are traceable to the national or international standards.
5. Version 2.0 supersedes all previous versions.

**Date of Issue:** 04 September 2015

**Checked by:**

Ian Watch  
Senior Engineer, Radio Laboratory

**Issued by :**

pp

John Newell  
Quality Manager,  
UL VS LTD



This laboratory is accredited by UKAS.  
The tests reported herein have been  
performed in accordance with its terms  
of accreditation.

---

## UL VS LTD

Pavilion A, Ashwood Park, Ashwood Way, Basingstoke, Hampshire, RG23 8BG, UK  
Telephone: +44 (0)1256 312000  
Facsimile: +44 (0)1256 312001

This page has been left intentionally blank.

**Table of Contents**

<b>1. Customer Information.....</b>	<b>4</b>
<b>2. Summary of Testing.....</b>	<b>5</b>
2.1. General Information	5
2.2. Summary of Test Results	5
2.3. Methods and Procedures	5
2.4. Deviations from the Test Specification	5
<b>3. Equipment Under Test (EUT) .....</b>	<b>6</b>
3.1. Identification of Equipment Under Test (EUT)	6
3.2. Description of EUT	6
3.3. Modifications Incorporated in the EUT	6
3.4. Additional Information Related to Testing	7
3.5. Support Equipment	9
<b>4. Operation and Monitoring of the EUT during Testing .....</b>	<b>10</b>
4.1. Operating Modes	10
4.2. Configuration and Peripherals	10
<b>5. Measurements, Examinations and Derived Results.....</b>	<b>11</b>
5.1. General Comments	11
5.2. Test Results	12
5.2.1. Transmitter Out of Band Radiated Emissions	12
<b>6. Measurement Uncertainty .....</b>	<b>20</b>
<b>7. Report Revision History .....</b>	<b>21</b>

**1. Customer Information**



<b>Company Name:</b>	Aava Mobile Oy
<b>Address:</b>	Nahkatehtaankatu 2 90130 Oulu Finland

## 2. Summary of Testing

### 2.1. General Information

<b>Specification Reference:</b>	47CFR15.407
<b>Specification Title:</b>	Code of Federal Regulations Volume 47 (Telecommunications): Part 15 Subpart E (Unlicensed National Information Infrastructure Devices) – Section 15.407
<b>Specification Reference:</b>	47CFR15.209
<b>Specification Title:</b>	Code of Federal Regulations Volume 47 (Telecommunications): Part 15 Subpart C (Intentional Radiators) - Sections 15.209
<b>Specification Reference:</b>	RSS-Gen Issue 4, November 13 2014
<b>Specification Title:</b>	General Requirements for Compliance of Radio Apparatus
<b>Specification Reference:</b>	RSS-247 Issue 1, May 28 2015
<b>Specification Title:</b>	Digital Transmission Systems (DTSs), Frequency Hopping Systems (FHSs) and Licence-Exempt Local Area Network (LE-LAN) Devices
<b>Site Registration:</b>	FCC: 209735; Industry Canada: 3245B-2
<b>Location of Testing:</b>	UL VS LTD, Unit 3 Horizon, Wade Road, Kingsland Business Park, Basingstoke, Hampshire, RG24 8AH, United Kingdom
<b>Test Dates:</b>	16 August 2015 to 23 August 2015

### 2.2. Summary of Test Results

FCC Reference (47CFR)	IC Reference	Measurement	Result
Parts 15.407(b) & 15.209(a)	RSS-Gen 6.13 & 8.9 / RSS-247 6.2	Transmitter Out of Band Radiated Emissions	
<b>Key to Results</b>			
 = Complied  = Did not comply			

### 2.3. Methods and Procedures

<b>Reference:</b>	ANSI C63.10-2013
<b>Title:</b>	American National Standard of Procedures for Compliance Testing of Unlicensed Wireless Devices
<b>Reference:</b>	KDB 789033 D02 General UNII Test Procedures New Rules v01 June 6, 2014
<b>Title:</b>	Guidelines for Compliance Testing of Unlicensed National Informamtion Infrastructure (U-NII) Devices – Part 15, Subpart E

### 2.4. Deviations from the Test Specification

For the measurements contained within this test report, there were no deviations from, additions to, or exclusions from the test specifications identified above.

### **3. Equipment Under Test (EUT)**

#### **3.1. Identification of Equipment Under Test (EUT)**

<b>Brand Name:</b>	Aava Mobile Oy
<b>Model Name or Number:</b>	INARI10-LTDN-2
<b>Test Sample Serial Number:</b>	BB44102116
<b>Hardware Version:</b>	Tablet PC: RU Wireless Module: 1.0, 1.1
<b>Software Version:</b>	Tablet PC :Windows Embedded 8.1 Industry Pro Build 9600 Wireless Module: SW19X15C_05.05.58.00
<b>FCC ID:</b>	2ABVH-INARI102
<b>Industry Canada Certification Number:</b>	11875A-INARI102

#### **3.2. Description of EUT**

The Equipment Under Test was a 10.1 inch tablet PC with cellular, WiFi, *Bluetooth* , NFC and GPS connectivity.

#### **3.3. Modifications Incorporated in the EUT**

No modifications were applied to the EUT during testing.

**3.4. Additional Information Related to Testing**

<b>Technology Tested:</b>	WLAN (IEEE 802.11a,n) / Digital Transmission System		
<b>Type of Unit:</b>	Transceiver		
<b>Modulation:</b>	BPSK, QPSK, 16QAM & 64QAM		
<b>Data rates:</b>	802.11a	6, 9, 12, 18, 24, 36 ,48 & 54 Mbit/s	
	802.11n HT20 (SISO)	MCS0 to MCS7	
	802.11n HT20 (MIMO)	MCS0 to MCS15 (CDD MCS0 to MCS7)	
	802.11n HT40 (SISO)	MCS0 to MCS7	
	802.11n HT40 (MIMO)	MCS0 to MCS15 (CDD MCS0 to MCS7)	
<b>Power Supply Requirement(s):</b>	Nominal	3.8 VDC	
<b>Channel Spacing:</b>	20 MHz		
<b>Transmit Frequency Band:</b>	5150 MHz to 5250 MHz		
<b>Transmit Channels Tested:</b>	<b>Channel ID</b>	<b>Channel Number</b>	<b>Channel Frequency (MHz)</b>
	Bottom	36	5180
	Middle	40	5200
	Top	48	5240
<b>Transmit Frequency Band:</b>	5250 MHz to 5350 MHz		
<b>Transmit Channels Tested:</b>	<b>Channel ID</b>	<b>Channel Number</b>	<b>Channel Frequency (MHz)</b>
	Bottom	52	5260
	Middle	56	5280
	Top	64	5320
<b>Transmit Frequency Band:</b>	5470 MHz to 5725 MHz		
<b>Transmit Channels Tested:</b>	<b>Channel ID</b>	<b>Channel Number</b>	<b>Channel Frequency (MHz)</b>
	Bottom	100	5500
	Middle	116	5580
	Top	140	5700
<b>Transmit Frequency Band:</b>	5725 MHz to 5850 MHz		
<b>Transmit Channels Tested:</b>	<b>Channel ID</b>	<b>Channel Number</b>	<b>Channel Frequency (MHz)</b>
	Bottom	149	5745
	Middle	157	5785
	Top	165	5825

**Additional Information Related to Testing (continued)**

<b>Channel Spacing:</b>	40 MHz		
<b>Transmit Frequency Band:</b>	5150 MHz to 5250 MHz		
<b>Transmit Channels Tested:</b>	<b>Channel ID</b>	<b>Channel Number</b>	<b>Channel Frequency (MHz)</b>
	Bottom	38	5190
	Top	46	5230
<b>Transmit Frequency Band:</b>	5250 MHz to 5350 MHz		
<b>Transmit Channels Tested:</b>	<b>Channel ID</b>	<b>Channel Number</b>	<b>Channel Frequency (MHz)</b>
	Bottom	54	5270
	Top	62	5310
<b>Transmit Frequency Band:</b>	5470 MHz to 5725 MHz		
<b>Transmit Channels Tested:</b>	<b>Channel ID</b>	<b>Channel Number</b>	<b>Channel Frequency (MHz)</b>
	Bottom	102	5510
	Middle	110	5550
	Top	134	5670
<b>Transmit Frequency Band:</b>	5725 MHz to 5850 MHz		
<b>Transmit Channels Tested:</b>	<b>Channel ID</b>	<b>Channel Number</b>	<b>Channel Frequency (MHz)</b>
	Bottom	151	5755
	Top	159	5795



### **3.5. Support Equipment**

The following support equipment was used to exercise the EUT during testing:

<b>Description:</b>	2 GB Micro SD Card
<b>Brand Name:</b>	Generic
<b>Model Name or Number:</b>	Not marked

<b>Brand Name:</b>	Delta Electronics Inc
<b>Description:</b>	AC/DC Adaptor
<b>Model Name or Number:</b>	ADP-10BW B
<b>Serial Number:</b>	05GW441000K

<b>Description:</b>	USB Cable
<b>Brand Name:</b>	None stated
<b>Model Name or Number:</b>	None stated
<b>Serial Number:</b>	None stated

<b>Description:</b>	PHF
<b>Brand Name:</b>	None stated
<b>Model Name or Number:</b>	None stated
<b>Serial Number:</b>	None stated

<b>Description:</b>	Male to Male USB Cable
<b>Brand Name:</b>	None stated
<b>Model Name or Number:</b>	None stated
<b>Serial Number:</b>	None stated

<b>Description:</b>	USB Hub
<b>Brand Name:</b>	Belkin
<b>Model Name or Number:</b>	F5U404-BLK
<b>Serial Number:</b>	D12-0047312

## **4. Operation and Monitoring of the EUT during Testing**

### **4.1. Operating Modes**

The EUT was tested in the following operating mode(s):

- Continuously transmitting with a modulated carrier at maximum power on the bottom, middle and top channels as required using the supported data rates/modulation types.

### **4.2. Configuration and Peripherals**

The EUT was tested in the following configuration(s):

- Controlled using a bespoke application on the laptop PC supplied by the customer. The application was used to enable continuous transmission and receive modes and to select the test channels, data rates and modulation schemes as required.
- Transmitter spurious emissions were performed with the EUT transmitting with a data rate of 6 Mbit/s. This was found to be the worst case modulation scheme with regards to emissions after preliminary investigations.
- The EUT was powered by its own 3.8 VDC internal battery. The DC output of an AC/DC power supply was connected to the EUT via a USB cable. The power supply input was connected to a 120 VAC 60 Hz single phase supply.
- All ports were terminated during radiated emissions testing.

## **5. Measurements, Examinations and Derived Results**

### **5.1. General Comments**

Measurement uncertainties are evaluated in accordance with current best practice. Our reported expanded uncertainties are based on standard uncertainties, which are multiplied by an appropriate coverage factor to provide a statistical confidence level of approximately 95%. Please refer to *Section 6 Measurement Uncertainty* for details.

In accordance with UKAS requirements all the measurement equipment is on a calibration schedule. All equipment was within the calibration period on the date of testing.

## **5.2. Test Results**

### **5.2.1. Transmitter Out of Band Radiated Emissions**

#### **Test Summary:**

<b>Test Engineers:</b>	Andrew Edwards	<b>Test Dates:</b>	23 August 2015
<b>Test Sample Serial Number:</b>	BB44102116		

<b>FCC Reference:</b>	Parts 15.407(b)(2),(6),(7) & 15.209(a)
<b>Industry Canada Reference:</b>	RSS-Gen 6.13 & 8.9 / RSS-247 6.2
<b>Test Method Used:</b>	FCC KDB 789033 II.G. & ANSI C63.10 Sections 6.3 and 6.5
<b>Frequency Range:</b>	30 MHz to 1000 MHz

#### **Environmental Conditions:**

<b>Temperature (°C):</b>	23
<b>Relative Humidity (%):</b>	41

#### **Note(s):**

1. Pre-scans were performed with the EUT transmitting on the middle channel of the 5.25 to 5.35 GHz band.
2. The final measured value, for the given emission in the field strength result tables, incorporates the calibrated antenna factor and cable loss.
3. All emissions shown on the pre-scan plot were found to be below the measurement system noise floor or ambient, therefore the highest peak noise floor reading of the measuring receiver was recorded in the table below.
4. Measurements below 1 GHz were performed in a semi-anechoic chamber (Asset Number K0001) at a distance of 3 metres. The EUT was placed at a height of 80 cm above the reference ground plane in the centre of the chamber turntable. Maximum emission levels were determined by height searching the measurement antenna over the range 1 metre to 4 metres.
5. Pre-scans were performed and markers placed on the highest measured levels. The test receiver resolution bandwidth was set to 100 kHz and video bandwidth 300 kHz. A peak detector was used, sweep time was set to auto and trace mode was Max Hold.

**Transmitter Out of Band Radiated Emissions (continued)**

**Test setup for radiated measurements: Semi-anechoic chamber**

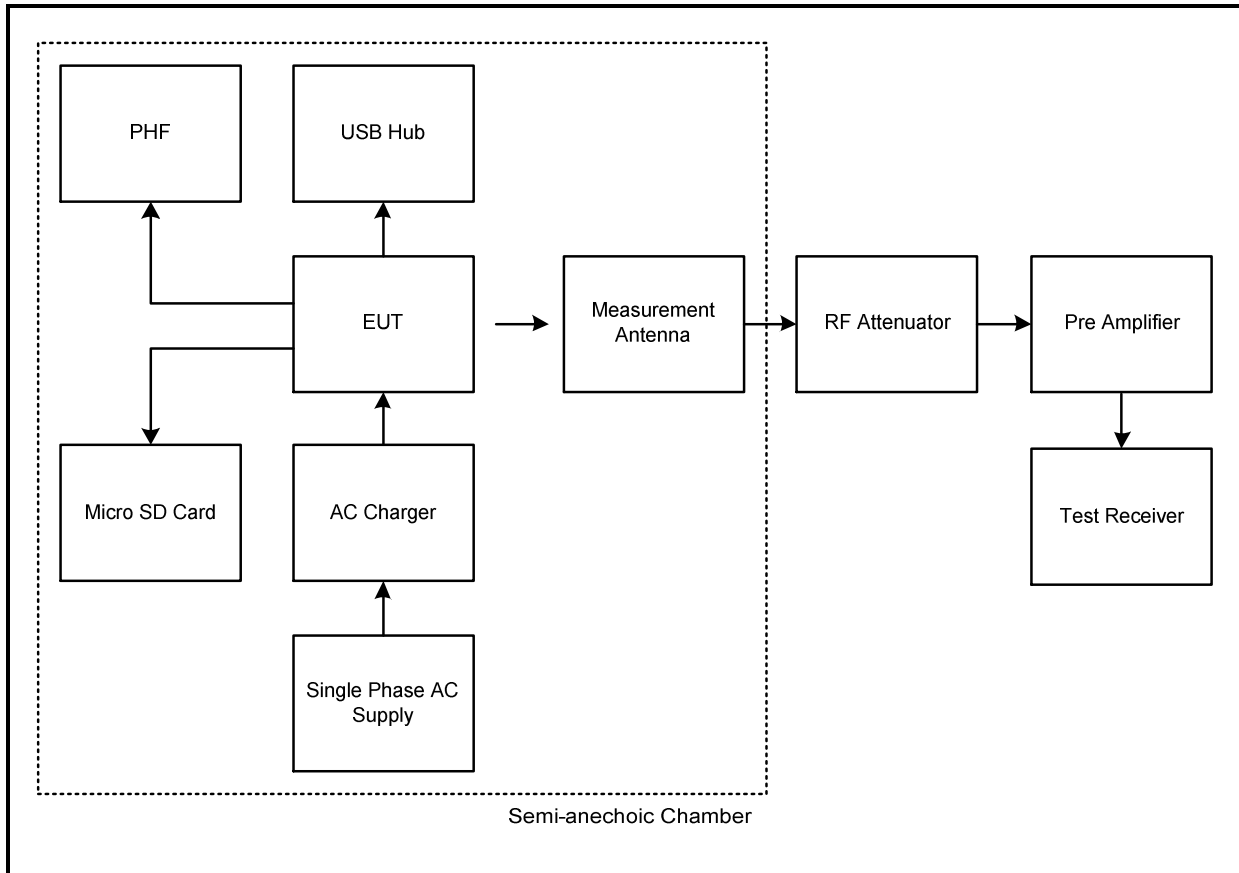

**Transmitter Out of Band Radiated Emissions (5.25-5.35 GHz band operation) (continued)**

**Results: Middle Channel / Field Strength**

Frequency (MHz)	Antenna Polarity	Level (dB $\mu$ V/m)	Limit (dB $\mu$ V/m)	Margin (dB)	Result
969.138	Horizontal	32.4	54.0	21.6	Complied

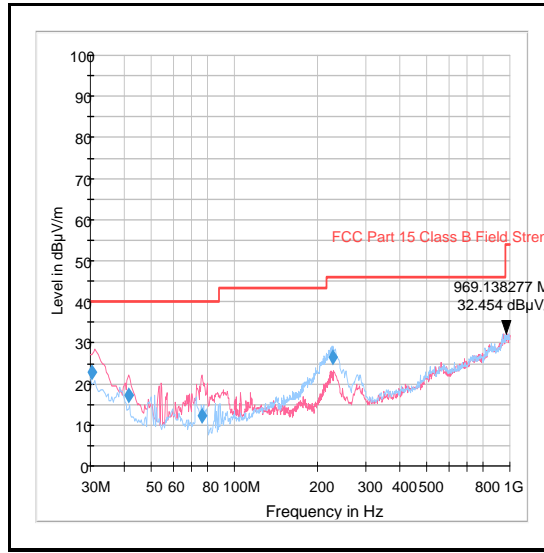

**Test Equipment Used:**

Asset No.	Instrument	Manufacturer	Type No.	Serial No.	Date Calibration Due	Cal. Interval (Months)
M1945	Thermohygrometer	JM Handelspunkt	30.5015.01	Not stated	23 Apr 2016	12
K0001	5m RSE Chamber	Rainford EMC	N/A	N/A	19 Mar 2016	12
M1273	Test Receiver	Rohde & Schwarz	ESIB26	100275	19 Mar 2016	12
A490	Bilog Antenna	Chase	CBL6111A	1590	30 Apr 2016	12
G0543	Amplifier	Sonoma	310N	230801	06 Nov 2015	3
A1834	Attenuator	Hewlett Packard	8491B	10444	05 Mar 2016	12

**Transmitter Out of Band Radiated Emissions (5.25-5.35 GHz band operation) (continued)****Test Summary:**

<b>Test Engineers:</b>	Nick Steele & Andrew Edwards	<b>Test Dates:</b>	16 August 2015 & 23 August 2015
<b>Test Sample Serial Number:</b>	BB44102116		

<b>FCC Reference:</b>	Part 15.407(b)(2),(7) & 15.209(a)
<b>Industry Canada Reference:</b>	RSS-Gen 6.13 & 8.9 / RSS-247 6.2
<b>Test Method Used:</b>	FCC KDB 789033 II.G. & ANSI C63.10 Sections 6.3 and 6.6
<b>Frequency Range:</b>	1 GHz to 40 GHz

**Environmental Conditions:**

<b>Temperature (°C):</b>	23 to 24
<b>Relative Humidity (%):</b>	39 to 41

**Note(s):**

1. Pre-scans were performed with the EUT transmitting on the middle channel of the 5.25 to 5.35 GHz band.
2. The final measured value, for the given emission in the field strength result tables, incorporates the calibrated antenna factor and cable loss.
3. Appropriate RF filters and attenuators were used during pre-scans and final measurements. Insertion losses were entered on the spectrum analyser as RF levels offsets.
4. The emission shown on the 4 GHz to 6 GHz plot is the EUT fundamental.
5. No spurious emissions were detected above the noise floor of the measuring receiver therefore the highest peak and average noise floor reading of the measuring receiver was recorded as shown in the tables below.
6. Pre-scans above 1 GHz were performed in a fully anechoic chamber (Asset Number K0002) at a distance of 3 metres. The EUT was placed at a height of 1.5 metres above the test chamber floor in the centre of the chamber turntable. All measurement antennas were placed at a fixed height of 1.5 metres above the test chamber floor, in line with the EUT. Final measurements above 1 GHz were performed in a semi-anechoic chamber (Asset Number K0001) at a distance of 3 metres. The EUT was placed at a height of 1.5 metres above the reference ground plane in the centre of the chamber turntable. Maximum emission levels were determined by height searching the measurement antenna over the range 1 metre to 4 metres.

**Transmitter Out of Band Radiated Emissions (continued)**

**Test setup for radiated measurements: Anechoic chamber**

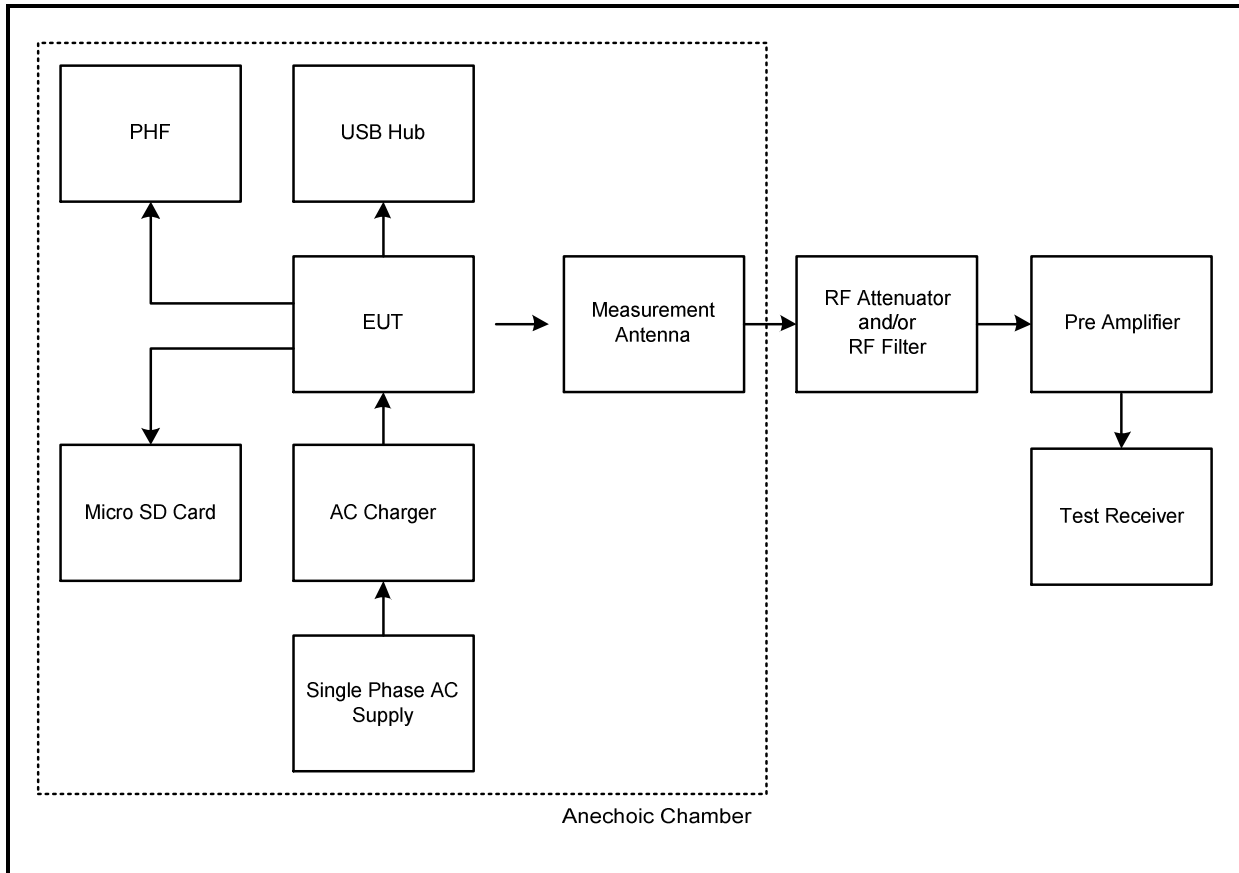



**Transmitter Out of Band Radiated Emissions (5.25-5.35 GHz band operation) (continued)**

**Results: Peak / Field Strength**

Frequency (MHz)	Antenna Polarity	Peak Level (dB $\mu$ V/m)	Peak Limit (dB $\mu$ V/m)	Margin (dB)	Result
5581.000	Vertical	51.5	74.0	22.5	Complied

**Results: Average / Field Strength**

Frequency (MHz)	Antenna Polarity	Average Level (dB $\mu$ V/m)	Average Limit (dB $\mu$ V/m)	Margin (dB)	Result
4501.500	Vertical	44.6	54.0	9.4	Complied

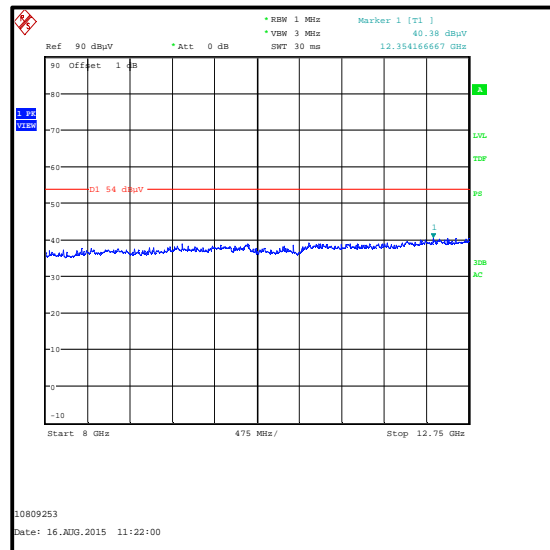
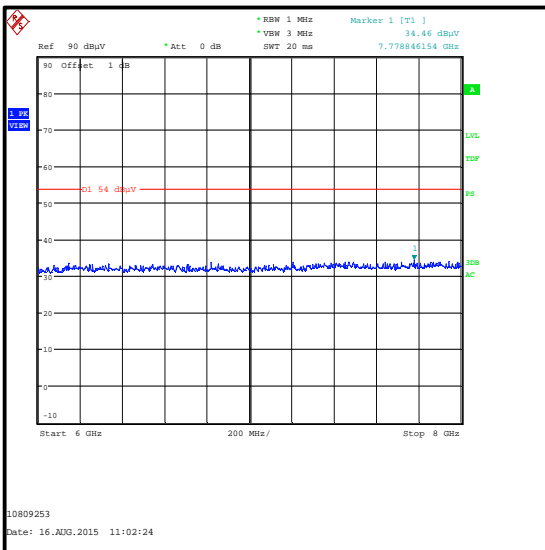
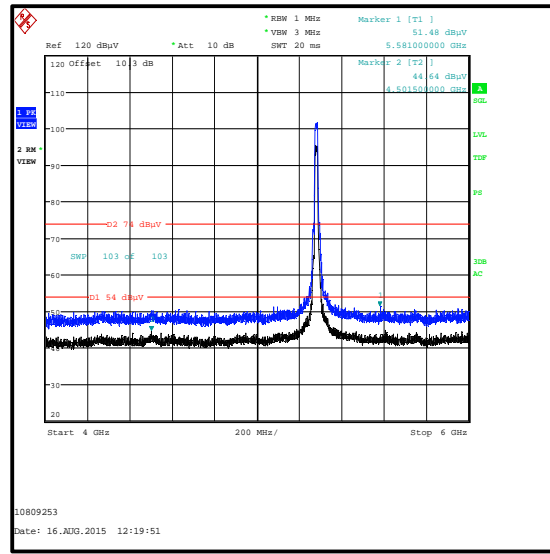
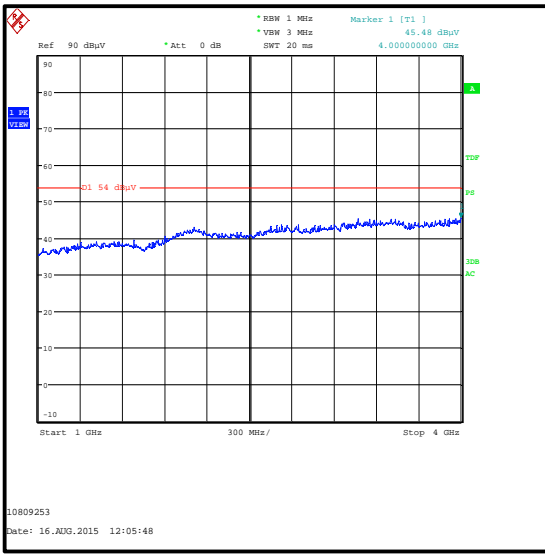

**Transmitter Out of Band Radiated Emissions (5.25-5.35 GHz band operation) (continued)**

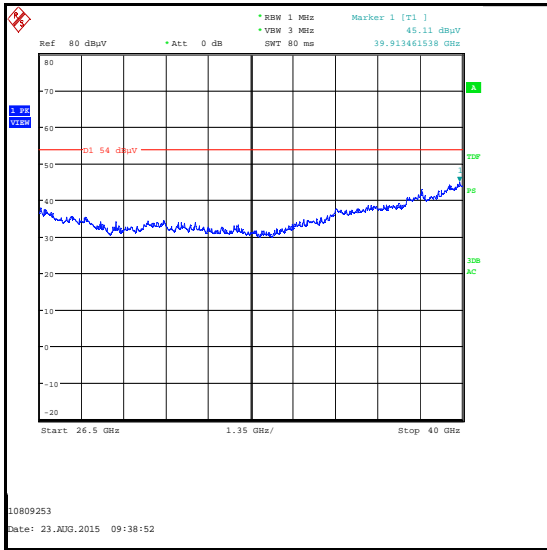
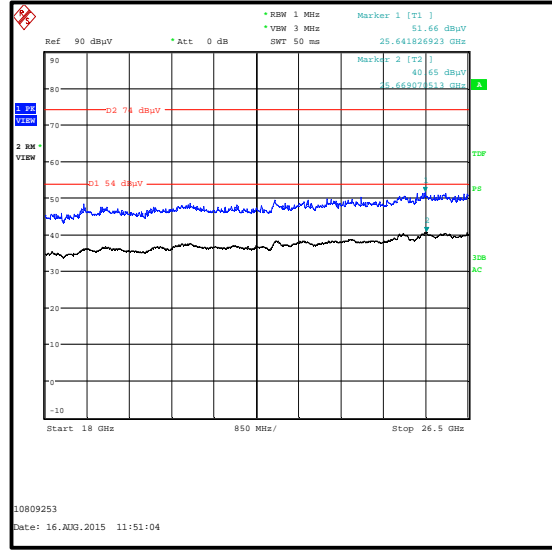
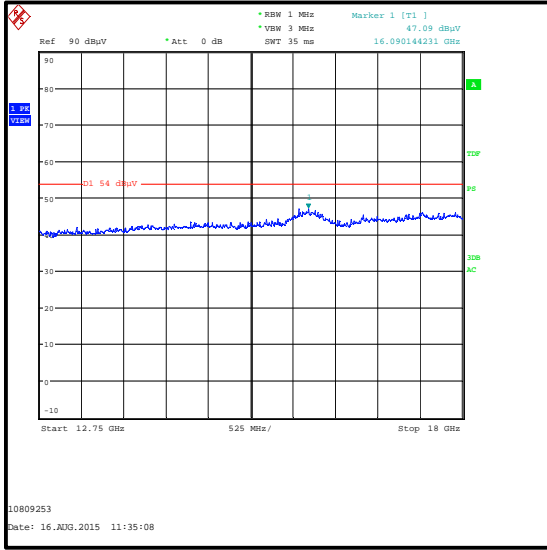

**Transmitter Out of Band Radiated Emissions (continued)****Test Equipment Used:**

Asset No.	Instrument	Manufacturer	Type No.	Serial No.	Date Calibration Due	Cal. Interval (Months)
M1656	Thermohygrometer	JM Handelspunkt	30.5015.13	None stated	23 Apr 2016	12
K0002	3m RSE Chamber	Rainford EMC	N/A	N/A	01 May 2016	12
M1874	Test Receiver	Rohde & Schwarz	ESU26	100553	12 Jun 2016	12
A1534	Pre Amplifier	Hewlett Packard	8449B	3008A00405	21 Dec 2015	12
A1396	Attenuator	Huber & Suhner	6810.17.B	757987	05 May 2016	12
A1980	High Pass Filter	AtlanTecRF	AFH-06000	09110900303	17 Apr 2016	12
A1818	Antenna	EMCO	3118	00075692	20 Dec 2015	12
A253	Antenna	Flann Microwave	12240-20	128	20 Dec 2015	12
A254	Antenna	Flann Microwave	14240-20	139	20 Dec 2015	12
A255	Antenna	Flann Microwave	16240-20	519	20 Dec 2015	12
A256	Antenna	Flann Microwave	18240-20	400	20 Dec 2015	12
A436	Antenna	Flann Microwave	20240-20	330	20 Dec 2015	12
A203	Antenna	Flann Microwave	22240-20	343	19 May 2016	36
M1630	Test Receiver	Rohde & Schwarz	ESU40	100233	20 Feb 2016	12
A1785	Pre Amplifier	Farran Technology	FLNA-28-30	FTL 6483	09 Jan 2016	12
M1229	Digital Multimeter	Fluke	179	87640015	22 Apr 2016	12
S0537	DC Power Supply Unit	TTI	EL302D	249928	Calibrated before use	-

## **6. Measurement Uncertainty**

No measurement or test can ever be perfect and the imperfections give rise to error of measurement in the results. Consequently the result of a measurement is only an approximation to the value of the measurand (the specific quantity subject to measurement) and is only complete when accompanied by a statement of the uncertainty of the approximation.

The expression of uncertainty of a measurement result allows realistic comparison of results with reference values and limits given in specifications and standards.

The uncertainty of the result may need to be taken into account when interpreting the measurement results.

The reported expanded uncertainties below are based on a standard uncertainty multiplied by an appropriate coverage factor such that a confidence level of approximately 95% is maintained. For the purposes of this document "approximately" is interpreted as meaning "effectively" or "for most practical purposes".

<b>Measurement Type</b>	<b>Range</b>	<b>Confidence Level (%)</b>	<b>Calculated Uncertainty</b>
Radiated Spurious Emissions	30 MHz to 1 GHz	95%	±5.65 dB
Radiated Spurious Emissions	1 GHz to 40 GHz	95%	±2.94 dB

The methods used to calculate the above uncertainties are in line with those recommended within the various measurement specifications. Where measurement specifications do not include guidelines for the evaluation of measurement uncertainty the published guidance of the appropriate accreditation body is followed.

## **7. Report Revision History**

Version Number	Revision Details		
	Page No(s)	Clause	Details
1.0	-	-	Initial Version
2.0	1 & 6	-	Changed Model Name from INARI10-LTDN-1 to INARI10-LTDN-2

**--- END OF REPORT ---**