

12.2. System Check Plots

This appendix contains the following system validation distribution scans.

Scan Reference Number	Title
001	System Performance Check 750MHz Body 17 06 15
002	System Performance Check 900MHz Body 11 06 15
003	System Performance Check 900MHz Body 15 06 15
004	System Performance Check 1800MHz Body 19 06 15
005	System Performance Check 1800MHz Body 22 06 15
006	System Performance Check 1900MHz Body 01 06 15
007	System Performance Check 1900MHz Body 22 06 15
008	System Performance Check 1900MHz Body 24 06 15
009	System Performance Check 1900MHz Body 29 06 15
010	System Performance Check 2450MHz Body 02 07 15
011	System Performance Check 2450MHz Body 06 07 15
012	System Performance Check 2450MHz Body 14 07 15
013	System Performance Check 5250 MHz Body 01 07 15
014	System Performance Check 5600 MHz Body 01 07 15
015	System Performance Check 5600 MHz Body 13 07 15
016	System Performance Check 5750 MHz Body 01 07 15
017	System Performance Check 5750 MHz Body 06 07 15

001: System Performance Check 750MHz Body 17 06 15

Date: 17/06/2015

DUT: Dipole 750 MHz; Type: D750V3; Serial: D750V3 - SN:1011

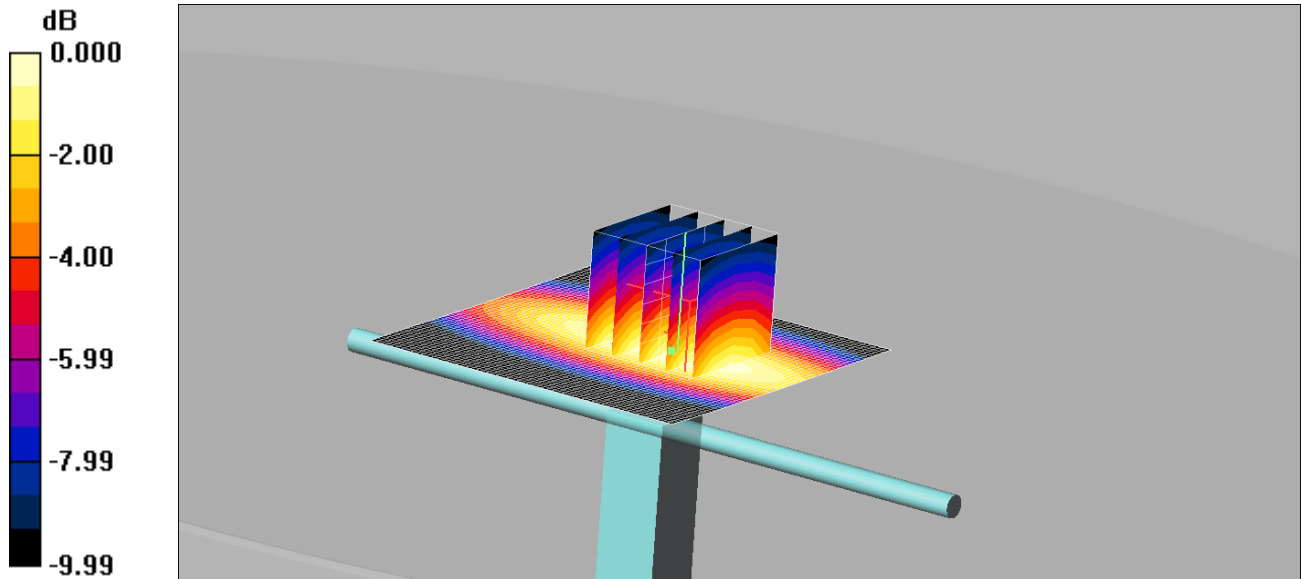

0 dB = 2.33mW/g

Communication System: CW; Frequency: 750 MHz; Duty Cycle: 1:1

Medium: 750 MHz MSL Medium parameters used: $f = 750 \text{ MHz}$; $\sigma = 0.965 \text{ mho/m}$; $\epsilon_r = 53.4$; $\rho = 1000 \text{ kg/m}^3$

Phantom section: Flat Section

DASY4 Configuration:

- Probe: ES3DV3 - SN3304; ConvF(6.17, 6.17, 6.17);
- Sensor-Surface: 4mm (Mechanical Surface Detection)
- Electronics: DAE3 Sn432; Calibrated: 20/08/2014
- Phantom: ELI v5.0; Type: QDOVA002AA;
- Measurement SW: DASY4, V4.7 Build 80; Postprocessing SW: SEMCAD, V1.8 Build 186

d=15mm, Pin=250mW/Area Scan (61x61x1): Measurement grid: dx=15mm, dy=15mm

Maximum value of SAR (interpolated) = 2.33 mW/g

d=15mm, Pin=250mW/Zoom Scan (5x5x7) (5x5x7)/Cube 0: Measurement grid: dx=8mm, dy=8mm, dz=5mm

Reference Value = 50.2 V/m; Power Drift = -0.005 dB

Peak SAR (extrapolated) = 3.09 W/kg

SAR(1 g) = 2.16 mW/g; SAR(10 g) = 1.44 mW/g

Maximum value of SAR (measured) = 2.33 mW/g

002: System Performance Check 900MHz Body 11 06 15

Date: 11/06/2015

DUT: Dipole 900 MHz; SN: 035; Type: D900V2; Serial: SN035

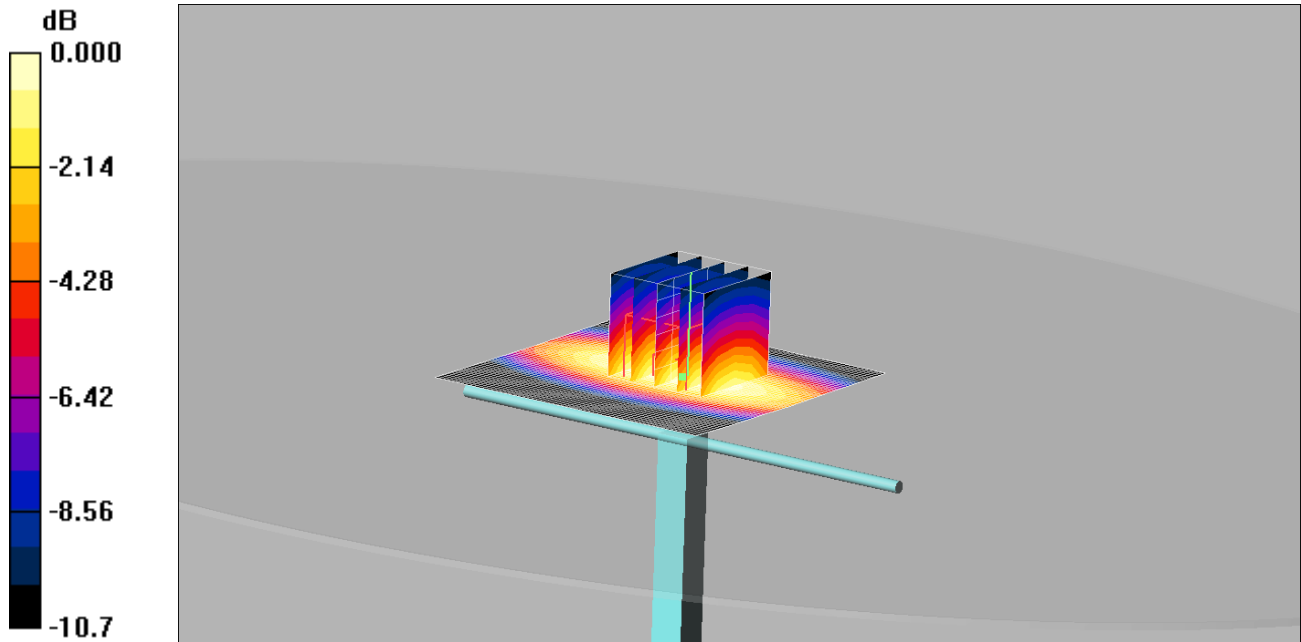

0 dB = 2.79mW/g

Communication System: CW; Frequency: 900 MHz; Duty Cycle: 1:1

Medium: 900 MHz MSL Medium parameters used: $f = 900 \text{ MHz}$; $\sigma = 1.06 \text{ mho/m}$; $\epsilon_r = 53.6$; $\rho = 1000 \text{ kg/m}^3$

Phantom section: Flat Section

DASY4 Configuration:

- Probe: ES3DV3 - SN3304; ConvF(6.03, 6.03, 6.03);
- Sensor-Surface: 4mm (Mechanical Surface Detection)
- Electronics: DAE3 Sn432; Calibrated: 20/08/2014
- Phantom: ELI v5.0; Type: QDOVA002AA;
- Measurement SW: DASY4, V4.7 Build 80; Postprocessing SW: SEMCAD, V1.8 Build 186

d=15mm, Pin=250mW 2/Area Scan (61x61x1): Measurement grid: dx=15mm, dy=15mm

Maximum value of SAR (interpolated) = 2.79 mW/g

d=15mm, Pin=250mW 2/Zoom Scan (5x5x7) (5x5x7)/Cube 0: Measurement grid: dx=8mm, dy=8mm, dz=5mm

Reference Value = 52.3 V/m; Power Drift = -0.032 dB

Peak SAR (extrapolated) = 3.80 W/kg

SAR(1 g) = 2.58 mW/g; SAR(10 g) = 1.69 mW/g

Maximum value of SAR (measured) = 2.79 mW/g

003: System Performance Check 900MHz Body 15 06 15

Date: 15/06/2015

DUT: Dipole 900 MHz; SN: 035; Type: D900V2; Serial: SN035

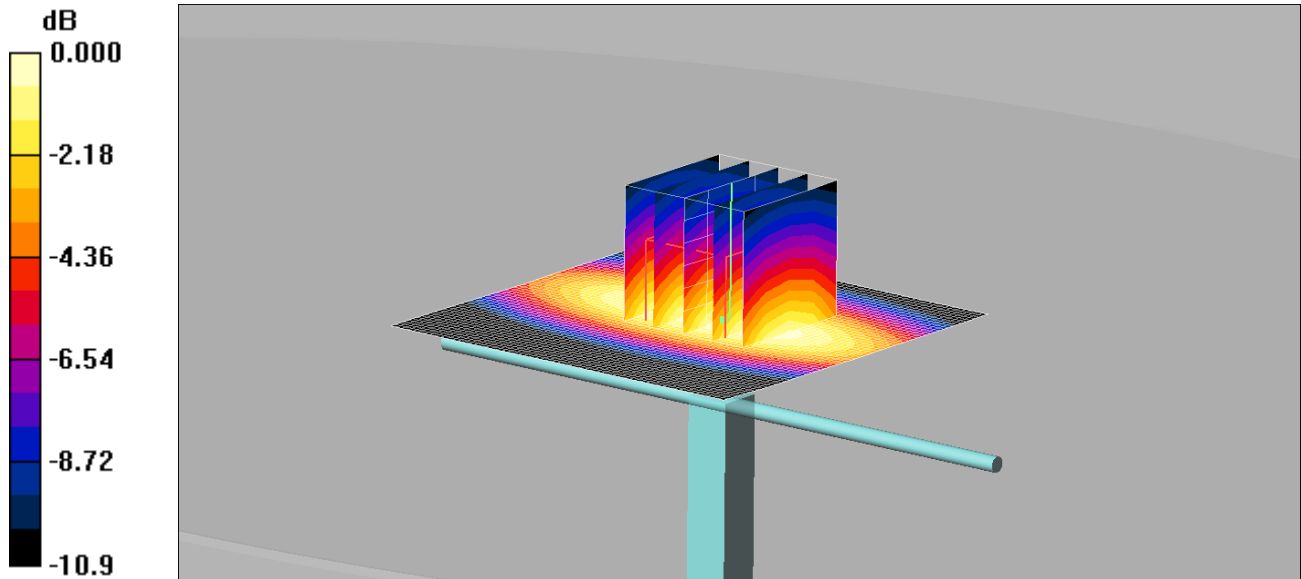

0 dB = 2.89mW/g

Communication System: CW; Frequency: 900 MHz; Duty Cycle: 1:1

Medium: 900 MHz MSL Medium parameters used: $f = 900 \text{ MHz}$; $\sigma = 1.06 \text{ mho/m}$; $\epsilon_r = 53.6$; $\rho = 1000 \text{ kg/m}^3$

Phantom section: Flat Section

DASY4 Configuration:

- Probe: ES3DV3 - SN3304; ConvF(6.03, 6.03, 6.03); - Sensor-Surface: 4mm

(Mechanical Surface Detection)

- Electronics: DAE3 Sn432; Calibrated: 20/08/2014

- Phantom: ELI v5.0; Type: QDOVA002AA;

- Measurement SW: DASY4, V4.7 Build 80; Postprocessing SW: SEMCAD, V1.8 Build 186

d=15mm, Pin=250mW/Area Scan (61x61x1): Measurement grid: dx=15mm, dy=15mm

Maximum value of SAR (interpolated) = 2.92 mW/g

d=15mm, Pin=250mW/Zoom Scan (5x5x7) (5x5x7)/Cube 0: Measurement grid: dx=8mm, dy=8mm, dz=5mm

Reference Value = 52.9 V/m; Power Drift = -0.003 dB

Peak SAR (extrapolated) = 3.94 W/kg

SAR(1 g) = 2.68 mW/g; SAR(10 g) = 1.74 mW/g

Maximum value of SAR (measured) = 2.89 mW/g

004: System Performance Check 1800MHz Body 19 06 15

Date: 19/06/2015

DUT: Dipole 1800 MHz; Type: D1800V2; Serial: 264

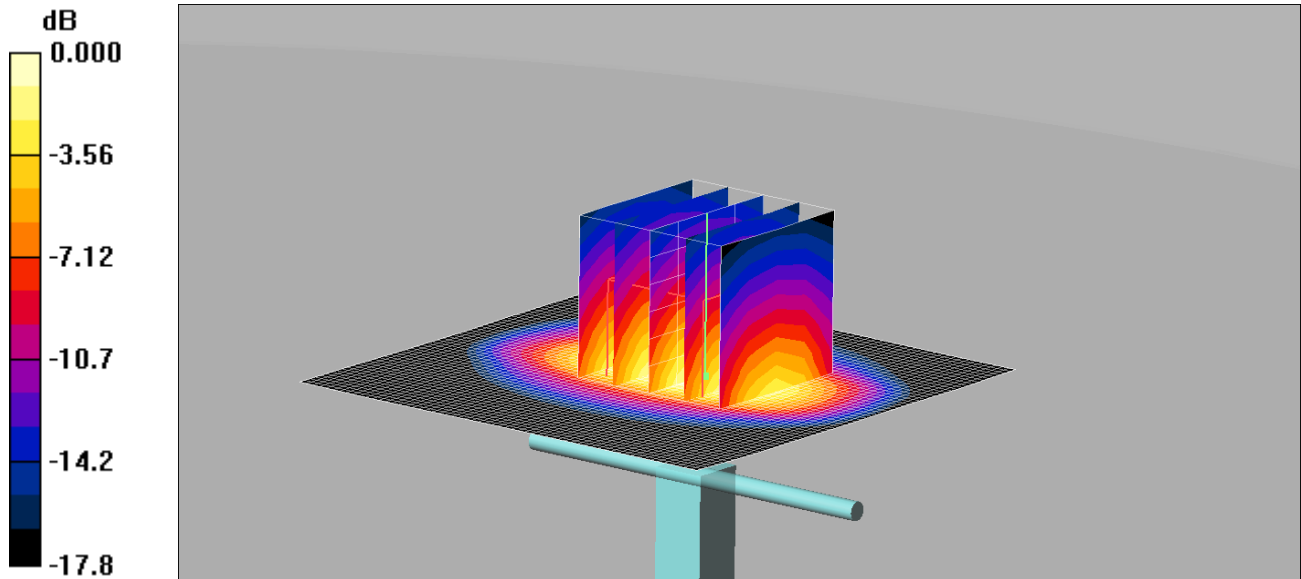

0 dB = 10.9mW/g

Communication System: CW; Frequency: 1800 MHz; Duty Cycle: 1:1

Medium: 1800 MHz MSL Medium parameters used: $f = 1800 \text{ MHz}$; $\sigma = 1.57 \text{ mho/m}$; $\epsilon_r = 52.3$; $\rho = 1000 \text{ kg/m}^3$

Phantom section: Flat Section

DASY4 Configuration:

- Probe: ES3DV3 - SN3304; ConvF(4.86, 4.86, 4.86);
- Sensor-Surface: 4mm (Mechanical Surface Detection)
- Electronics: DAE3 Sn432; Calibrated: 20/08/2014
- Phantom: ELI v5.0; Type: QDOVA002AA;
- Measurement SW: DASY4, V4.7 Build 80; Postprocessing SW: SEMCAD, V1.8 Build 186

d=10mm, Pin=250mW/Area Scan (61x61x1): Measurement grid: dx=15mm, dy=15mm

Maximum value of SAR (interpolated) = 12.5 mW/g

d=10mm, Pin=250mW/Zoom Scan (5x5x7) (5x5x7)/Cube 0: Measurement grid: dx=8mm, dy=8mm, dz=5mm

Reference Value = 84.7 V/m; Power Drift = 0.000 dB

Peak SAR (extrapolated) = 17.9 W/kg

SAR(1 g) = 9.76 mW/g; SAR(10 g) = 5.1 mW/g

Maximum value of SAR (measured) = 10.9 mW/g

005: System Performance Check 1800MHz Body 22 06 15

Date: 22/06/2015

DUT: Dipole 1800 MHz; Type: D1800V2; Serial: 264

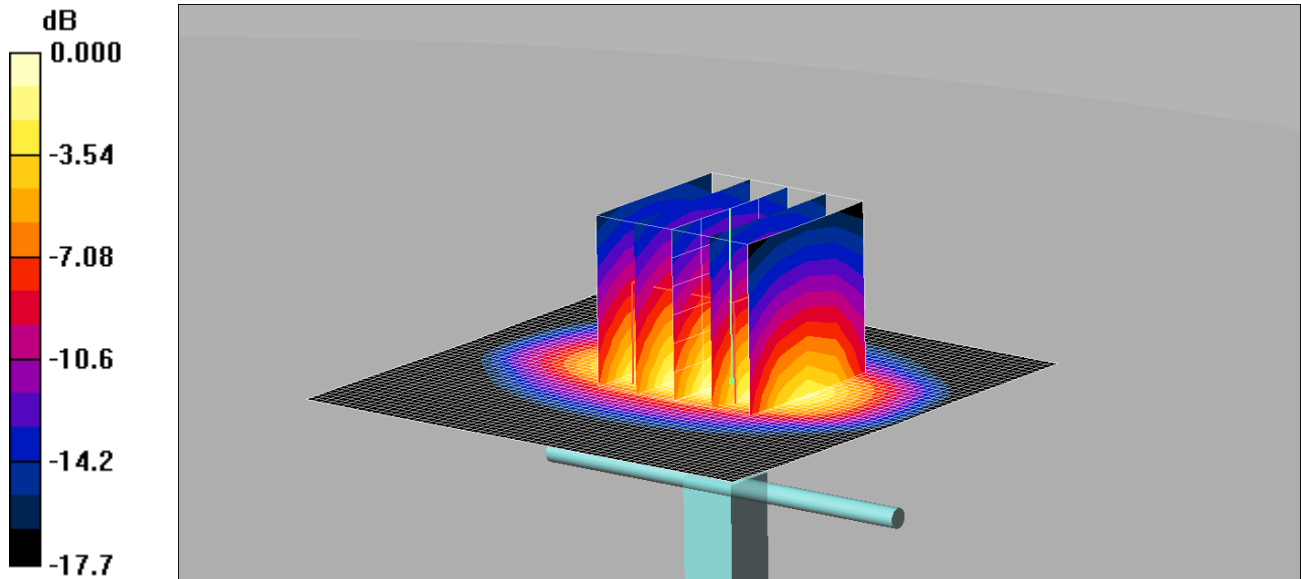

0 dB = 10.6mW/g

Communication System: CW; Frequency: 1800 MHz; Duty Cycle: 1:1

Medium: 1800 MHz MSL Medium parameters used: $f = 1800 \text{ MHz}$; $\sigma = 1.57 \text{ mho/m}$; $\epsilon_r = 52.3$; $\rho = 1000 \text{ kg/m}^3$

Phantom section: Flat Section

DASY4 Configuration:

- Probe: ES3DV3 - SN3304; ConvF(4.86, 4.86, 4.86);
- Sensor-Surface: 4mm (Mechanical Surface Detection)
- Electronics: DAE3 Sn432; Calibrated: 20/08/2014
- Phantom: ELI v5.0; Type: QDOVA002AA;
- Measurement SW: DASY4, V4.7 Build 80; Postprocessing SW: SEMCAD, V1.8 Build 186

d=10mm, Pin=250mW/Area Scan (61x61x1): Measurement grid: dx=15mm, dy=15mm

Maximum value of SAR (interpolated) = 12.1 mW/g

d=10mm, Pin=250mW/Zoom Scan (5x5x7) (5x5x7)/Cube 0: Measurement grid: dx=8mm, dy=8mm, dz=5mm

Reference Value = 83.5 V/m; Power Drift = 0.011 dB

Peak SAR (extrapolated) = 17.4 W/kg

SAR(1 g) = 9.5 mW/g; SAR(10 g) = 4.98 mW/g

Maximum value of SAR (measured) = 10.6 mW/g

006: System Performance Check 1900MHz Body 01 06 15

Date: 01/06/2015

DUT: Dipole 1900 MHz; SN540; Type: D1900V2; Serial: SN540

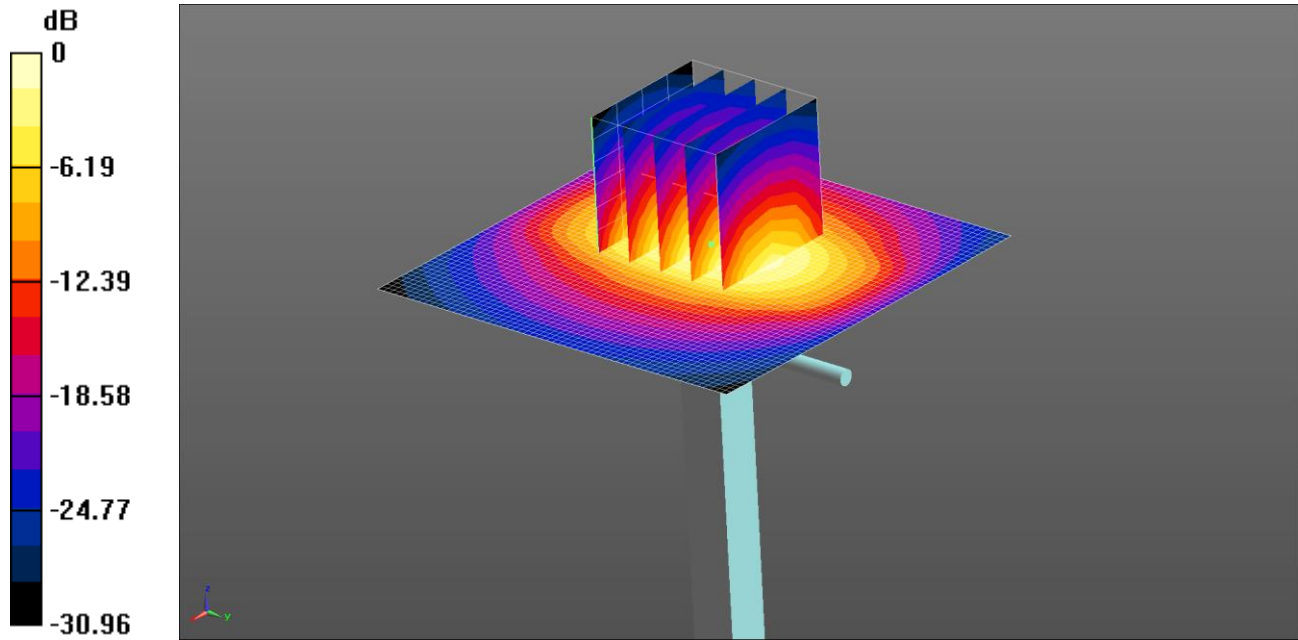

0 dB = 11.9 W/kg = 10.75 dBW/kg

Communication System: UID 0, CW (0); Frequency: 1900 MHz; Duty Cycle: 1:1

Medium: 1900MHz MSL Medium parameters used: $f = 1900 \text{ MHz}$; $\sigma = 1.475 \text{ S/m}$; $\epsilon_r = 52.565$; $\rho = 1000 \text{ kg/m}^3$

Phantom section: Flat Section

DASY4 Configuration:

- Probe: EX3DV4 - SN3994; ConvF(7.63, 7.63, 7.63); Calibrated: 17/03/2015;
- Sensor-Surface: 4mm (Mechanical Surface Detection)
- Electronics: DAE3 Sn450; Calibrated: 16/09/2014
- Phantom: ELI v5.0; Type: QDOVA002AA;
- ; SEMCAD X Version 14.6.10 (7164)

SAR/d=10mm, Pin=250 mW, dist=10.0mm (ET-Probe)/Area Scan (61x61x1): Interpolated grid: $dx=1.500 \text{ mm}$, $dy=1.500 \text{ mm}$

Maximum value of SAR (interpolated) = 11.9 W/kg

SAR/d=10mm, Pin=250 mW, dist=10.0mm (ET-Probe)/Zoom Scan (5x5x7) (5x5x7)/Cube 0: Measurement grid: $dx=8\text{mm}$, $dy=8\text{mm}$, $dz=5\text{mm}$

Reference Value = 85.060 V/m; Power Drift = 0.03 dB

Peak SAR (extrapolated) = 18.8 W/kg

SAR(1 g) = 10.3 W/kg; SAR(10 g) = 5.37 W/kg

Maximum value of SAR (measured) = 11.6 W/kg

007: System Performance Check 1900MHz Body 22 06 15

Date: 22/06/2015

DUT: Dipole 1900 MHz; SN540; Type: D1900V2; Serial: SN540

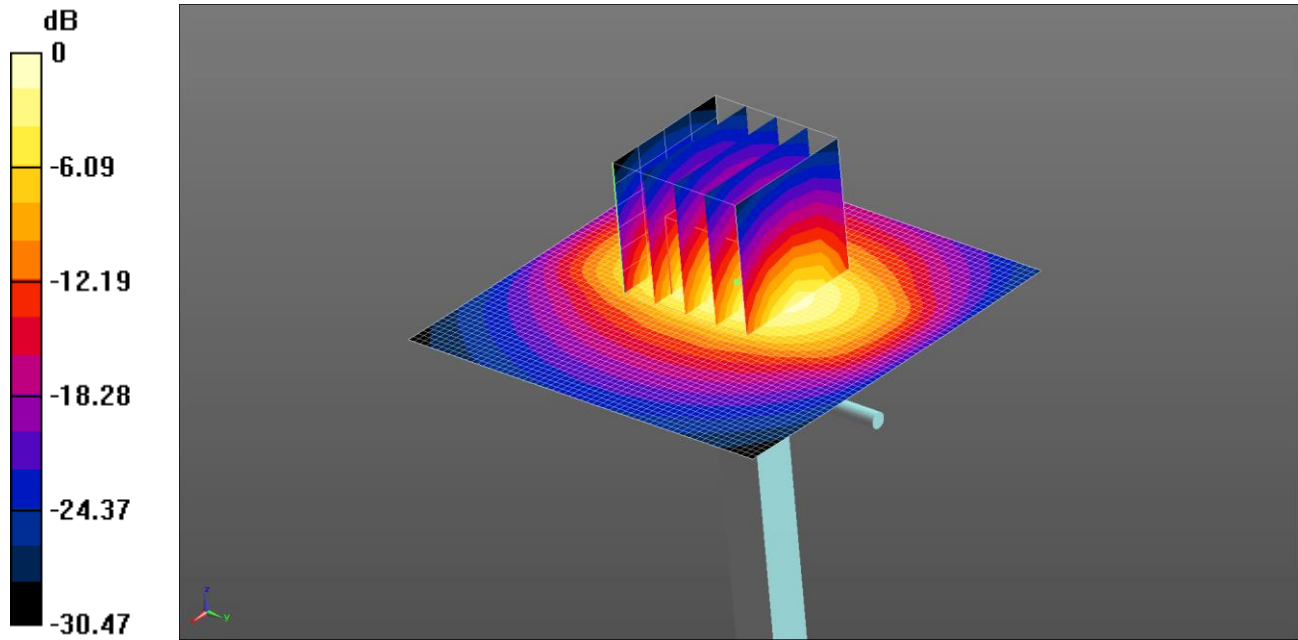

0 dB = 11.6 W/kg = 10.64 dBW/kg

Communication System: UID 0, CW (0); Frequency: 1900 MHz; Duty Cycle: 1:1

Medium: 1900MHz MSL Medium parameters used: $f = 1900 \text{ MHz}$; $\sigma = 1.46 \text{ S/m}$; $\epsilon_r = 51.586$; $\rho = 1000 \text{ kg/m}^3$

Phantom section: Flat Section

DASY4 Configuration:

- Probe: ES3DV3 - SN3335; ConvF(4.69, 4.69, 4.69); Calibrated: 29/08/2014;
- Sensor-Surface: 4mm (Mechanical Surface Detection)
- Electronics: DAE3 Sn450; Calibrated: 16/09/2014
- Phantom: ELI v5.0; Type: QDOVA002AA;
- ; SEMCAD X Version 14.6.10 (7164)

SAR/d=10mm, Pin=250 mW, dist=10.0mm (ET-Probe) 2/Area Scan (61x61x1): Interpolated grid: $dx=1.500 \text{ mm}$, $dy=1.500 \text{ mm}$

Maximum value of SAR (interpolated) = 11.6 W/kg

SAR/d=10mm, Pin=250 mW, dist=10.0mm (ET-Probe) 2/Zoom Scan (5x5x7) (5x5x7)/Cube 0: Measurement grid: $dx=8\text{mm}$, $dy=8\text{mm}$, $dz=5\text{mm}$

Reference Value = 84.951 V/m; Power Drift = 0.06 dB

Peak SAR (extrapolated) = 17.8 W/kg

SAR(1 g) = 9.94 W/kg; SAR(10 g) = 5.23 W/kg

Maximum value of SAR (measured) = 11.1 W/kg

008: System Performance Check 1900MHz Body 24 06 15

Date: 24/06/2015

DUT: Dipole 1900 MHz; Type: D1900V2; Serial: SN540

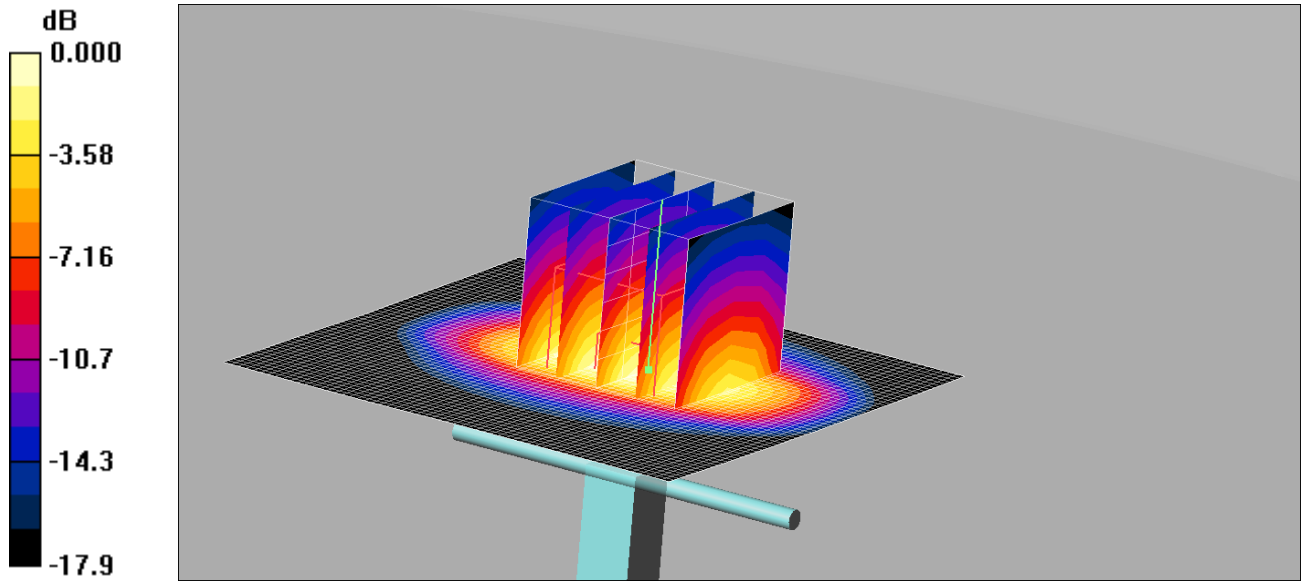

0 dB = 11.3mW/g

Communication System: CW; Frequency: 1900 MHz; Duty Cycle: 1:1

Medium: 1900 MHz MSL Medium parameters used: $f = 1900 \text{ MHz}$; $\sigma = 1.49 \text{ mho/m}$; $\epsilon_r = 52.5$; $\rho = 1000 \text{ kg/m}^3$

Phantom section: Flat Section

DASY4 Configuration:

- Probe: ES3DV3 - SN3304; ConvF(4.69, 4.69, 4.69);
- Sensor-Surface: 4mm (Mechanical Surface Detection)
- Electronics: DAE3 Sn432; Calibrated: 20/08/2014
- Phantom: ELI v5.0; Type: QDOVA002AA;
- Measurement SW: DASY4, V4.7 Build 80; Postprocessing SW: SEMCAD, V1.8 Build 186

d=10mm, Pin=250mW 2 2/Area Scan (61x61x1): Measurement grid: dx=15mm, dy=15mm
 Maximum value of SAR (interpolated) = 12.9 mW/g

d=10mm, Pin=250mW 2 2/Zoom Scan (5x5x7) (5x5x7)/Cube 0: Measurement grid: dx=8mm, dy=8mm, dz=5mm
 Reference Value = 88.3 V/m; Power Drift = -0.001 dB

Peak SAR (extrapolated) = 18.1 W/kg

SAR(1 g) = 10.2 mW/g; SAR(10 g) = 5.34 mW/g

Maximum value of SAR (measured) = 11.3 mW/g

009: System Performance Check 1900MHz Body 29 06 15

Date: 29/06/2015

DUT: Dipole 1900 MHz; Type: D1900V2; Serial: SN540

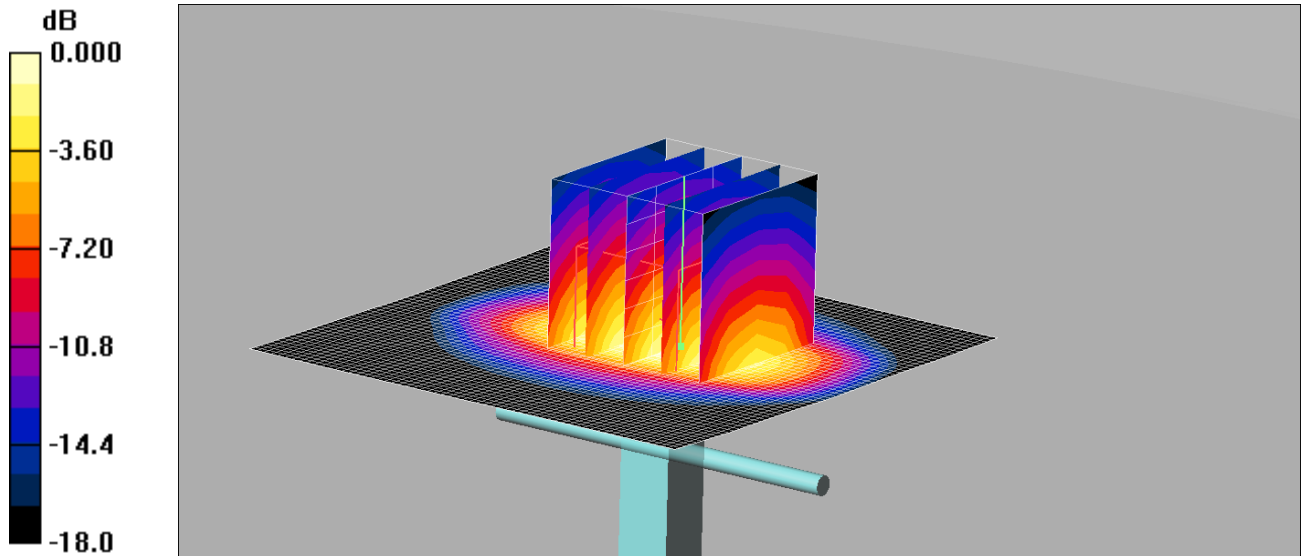

0 dB = 11.4mW/g

Communication System: CW; Frequency: 1900 MHz; Duty Cycle: 1:1

Medium: 1900 MHz MSL Medium parameters used: $f = 1900 \text{ MHz}$; $\sigma = 1.49 \text{ mho/m}$; $\epsilon_r = 52.5$; $\rho = 1000 \text{ kg/m}^3$

Phantom section: Flat Section

DASY4 Configuration:

- Probe: ES3DV3 - SN3304; ConvF(4.69, 4.69, 4.69);

- Sensor-Surface: 4mm

(Mechanical Surface Detection)

- Electronics: DAE3 Sn432; Calibrated: 20/08/2014

- Phantom: ELI v5.0; Type: QDOVA002AA;

- Measurement SW: DASY4, V4.7 Build 80; Postprocessing SW: SEMCAD, V1.8 Build 186

d=10mm, Pin=250mW 2 2/Area Scan (61x61x1): Measurement grid: dx=15mm, dy=15mm

Maximum value of SAR (interpolated) = 13.0 mW/g

d=10mm, Pin=250mW 2 2/Zoom Scan (5x5x7) (5x5x7)/Cube 0: Measurement grid: dx=8mm, dy=8mm, dz=5mm

Reference Value = 89.5 V/m; Power Drift = 0.018 dB

Peak SAR (extrapolated) = 18.1 W/kg

SAR(1 g) = 10.2 mW/g; SAR(10 g) = 5.36 mW/g

Maximum value of SAR (measured) = 11.4 mW/g

010: System Performance Check 2450MHz Body 02 07 15

Date: 02/07/2015

DUT: Dipole 2450 MHz; SN725; Type: D2450V2; Serial: D2450V2 - SN:725

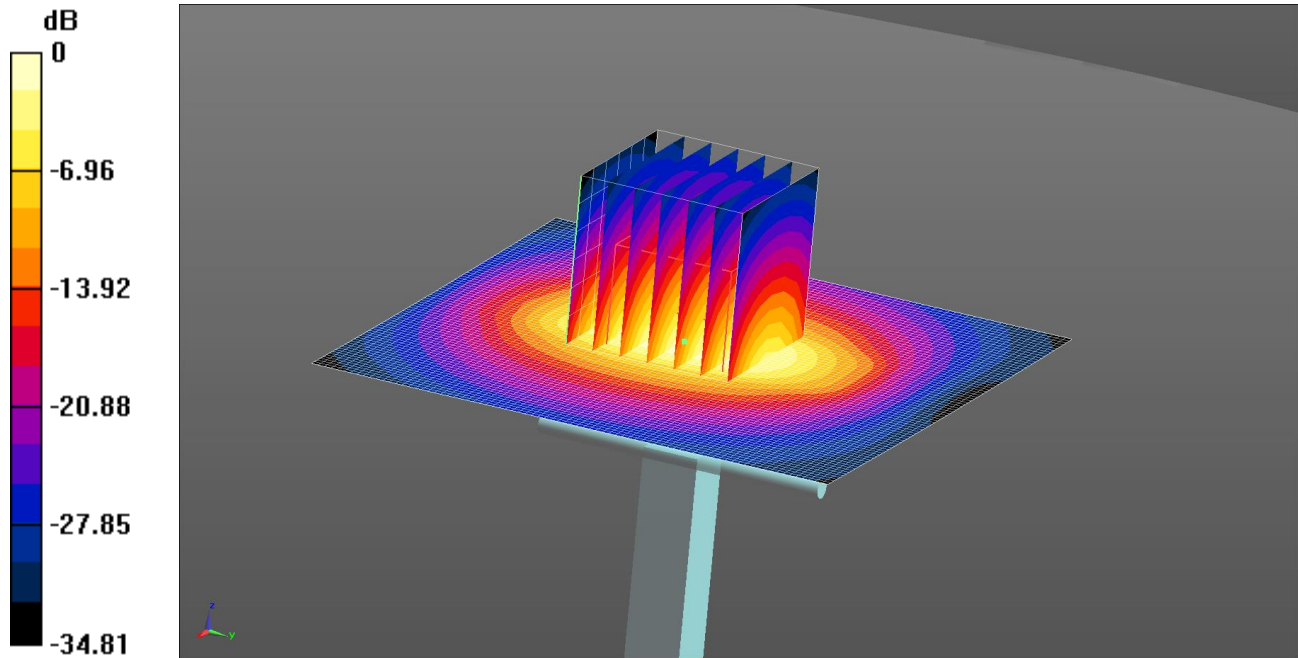

0 dB = 14.7 W/kg = 11.68 dBW/kg

Communication System: UID 0, CW (0); Frequency: 2450 MHz; Duty Cycle: 1:1

Medium: 2450MHz MSL Medium parameters used: $f = 2450$ MHz; $\sigma = 1.937$ S/m; $\epsilon_r = 53.196$; $\rho = 1000$ kg/m³

Phantom section: Flat Section

DASY4 Configuration:

- Probe: ES3DV3 - SN3335; ConvF(4.28, 4.28, 4.28); Calibrated: 29/08/2014;

- Sensor-Surface:

4mm (Mechanical Surface Detection)

- Electronics: DAE3 Sn450; Calibrated: 16/09/2014

- Phantom: ELI v5.0; Type: QDOVA002AA;

- ; SEMCAD X Version 14.6.10 (7164)

Configuration/d=10mm, Pin=250mW/Area Scan (81x81x1): Interpolated grid: dx=1.200 mm, dy=1.200 mm

Maximum value of SAR (interpolated) = 14.7 W/kg

Configuration/d=10mm, Pin=250mW/Zoom Scan (7x7x7) (7x7x7)/Cube 0: Measurement grid: dx=5mm, dy=5mm, dz=5mm

Reference Value = 76.504 V/m; Power Drift = 0.09 dB

Peak SAR (extrapolated) = 25.7 W/kg

SAR(1 g) = 12.5 W/kg; SAR(10 g) = 5.87 W/kg

Maximum value of SAR (measured) = 14.3 W/kg

011: System Performance Check 2450MHz Body 06 07 15

Date: 06/07/2015

DUT: Dipole 2450 MHz; SN725; Type: D2450V2; Serial: D2450V2 - SN:725

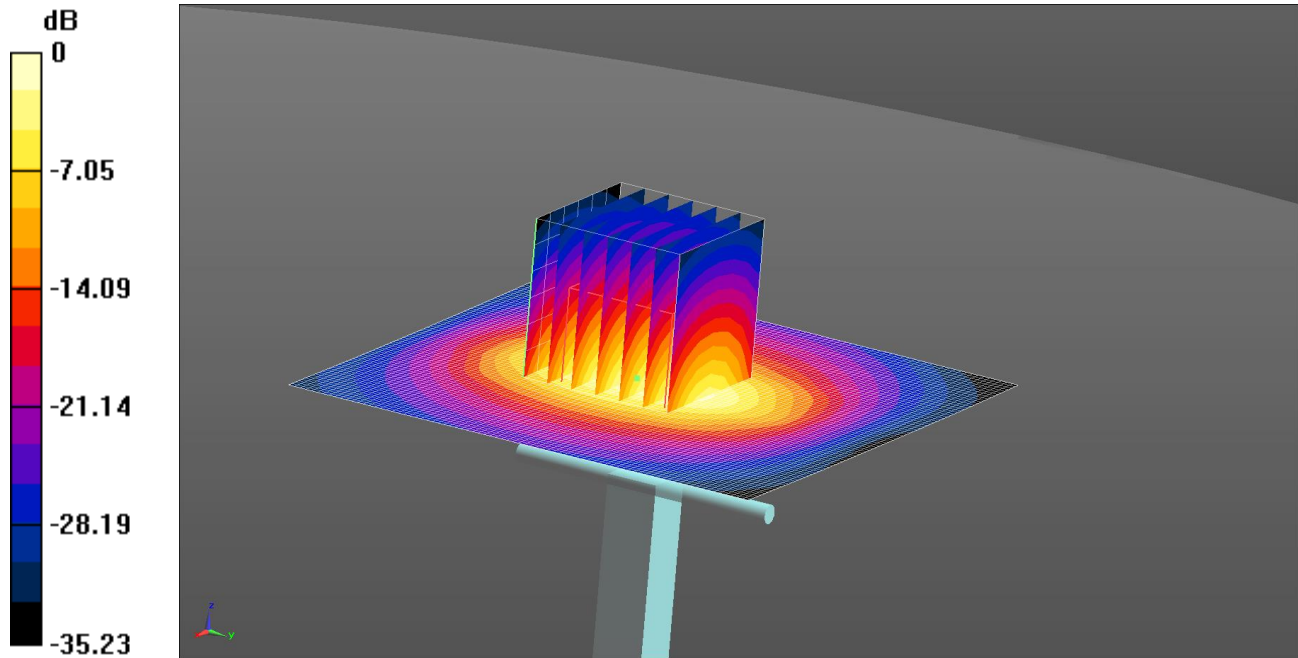

0 dB = 15.0 W/kg = 11.76 dBW/kg

Communication System: UID 0, CW (0); Frequency: 2450 MHz; Duty Cycle: 1:1

Medium: 2450MHz MSL Medium parameters used: $f = 2450$ MHz; $\sigma = 2.018$ S/m; $\epsilon_r = 52.403$; $\rho = 1000$ kg/m³

Phantom section: Flat Section

DASY4 Configuration:

- Probe: ES3DV3 - SN3335; ConvF(4.28, 4.28, 4.28); Calibrated: 29/08/2014;
- Sensor-Surface: 4mm (Mechanical Surface Detection)
- Electronics: DAE3 Sn450; Calibrated: 16/09/2014
- Phantom: ELI v5.0; Type: QDOVA002AA;
- ; SEMCAD X Version 14.6.10 (7164)

Configuration/d=10mm, Pin=250mW/Area Scan (81x81x1): Interpolated grid: dx=1.200 mm, dy=1.200 mm

Maximum value of SAR (interpolated) = 15.0 W/kg

Configuration/d=10mm, Pin=250mW/Zoom Scan (7x7x7) (7x7x7)/Cube 0: Measurement grid: dx=5mm, dy=5mm, dz=5mm

Reference Value = 83.804 V/m; Power Drift = 0.03 dB

Peak SAR (extrapolated) = 27.0 W/kg

SAR(1 g) = 12.9 W/kg; SAR(10 g) = 5.99 W/kg

Maximum value of SAR (measured) = 14.7 W/kg

012: System Performance Check 2450MHz Body 14 07 15

Date: 14/07/2015

DUT: Dipole 2450 MHz; SN725; Type: D2450V2; Serial: D2450V2 - SN:725

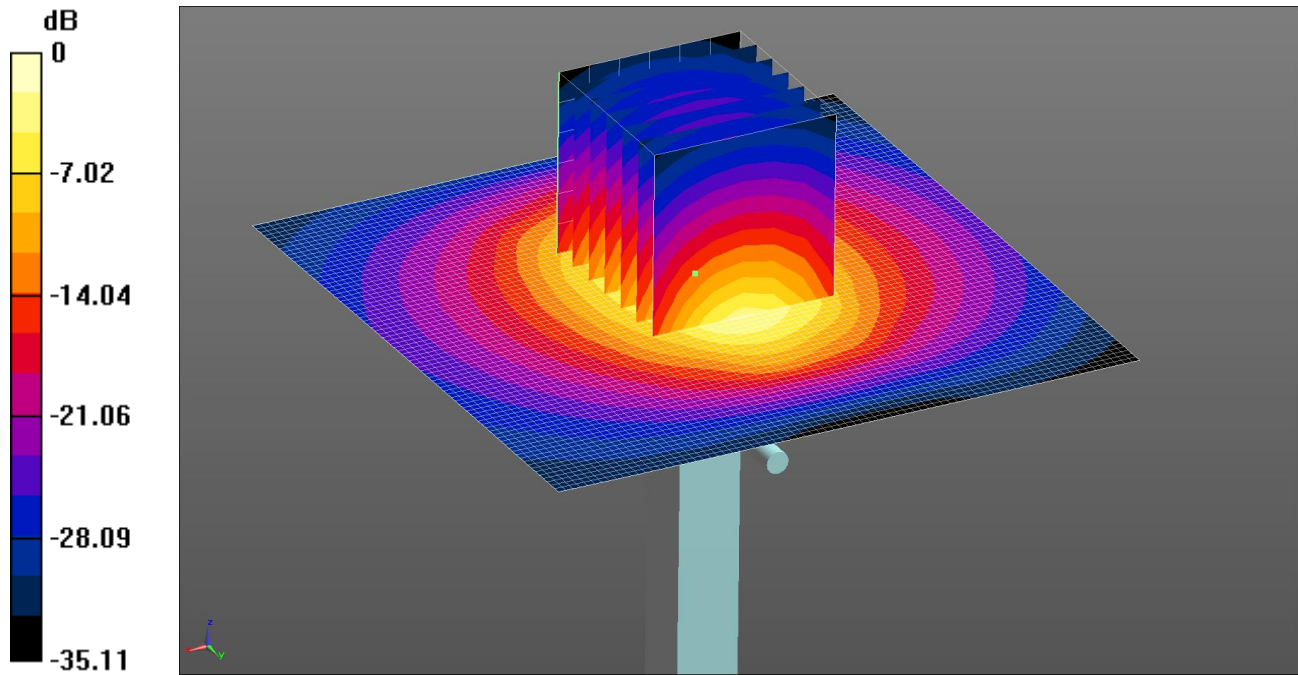

0 dB = 19.8 W/kg = 12.96 dBW/kg

Communication System: UID 0, CW (0); Frequency: 2450 MHz; Duty Cycle: 1:1

Medium: 2450MHz MSL Medium parameters used: $f = 2450$ MHz; $\sigma = 1.984$ S/m; $\epsilon_r = 52.039$; $\rho = 1000$ kg/m³

Phantom section: Flat Section

DASY4 Configuration:

- Probe: EX3DV4 - SN3995; ConvF(7.4, 7.4, 7.4); Calibrated: 28/04/2015;
- Sensor-Surface: 2mm (Mechanical Surface Detection)
- Electronics: DAE3 Sn450; Calibrated: 16/09/2014
- Phantom: ELI v5.0; Type: QDOVA002AA;
- ; SEMCAD X Version 14.6.10 (7164)

Configuration/d=10mm, Pin=250mW/Area Scan (81x81x1): Interpolated grid: dx=1.200 mm, dy=1.200 mm

Maximum value of SAR (interpolated) = 19.8 W/kg

Configuration/d=10mm, Pin=250mW/Zoom Scan (7x7x7) (7x7x7)/Cube 0: Measurement grid: dx=5mm, dy=5mm, dz=5mm

Reference Value = 84.163 V/m; Power Drift = 0.03 dB

Peak SAR (extrapolated) = 26.2 W/kg

SAR(1 g) = 12.7 W/kg; SAR(10 g) = 5.94 W/kg

Maximum value of SAR (measured) = 19.4 W/kg

013: System Performance Check 5250 MHz Body 01 07 15

Date: 01/07/2015

DUT: 5GHz Dipole; Type: D5GHzV2; Serial: SN 1016

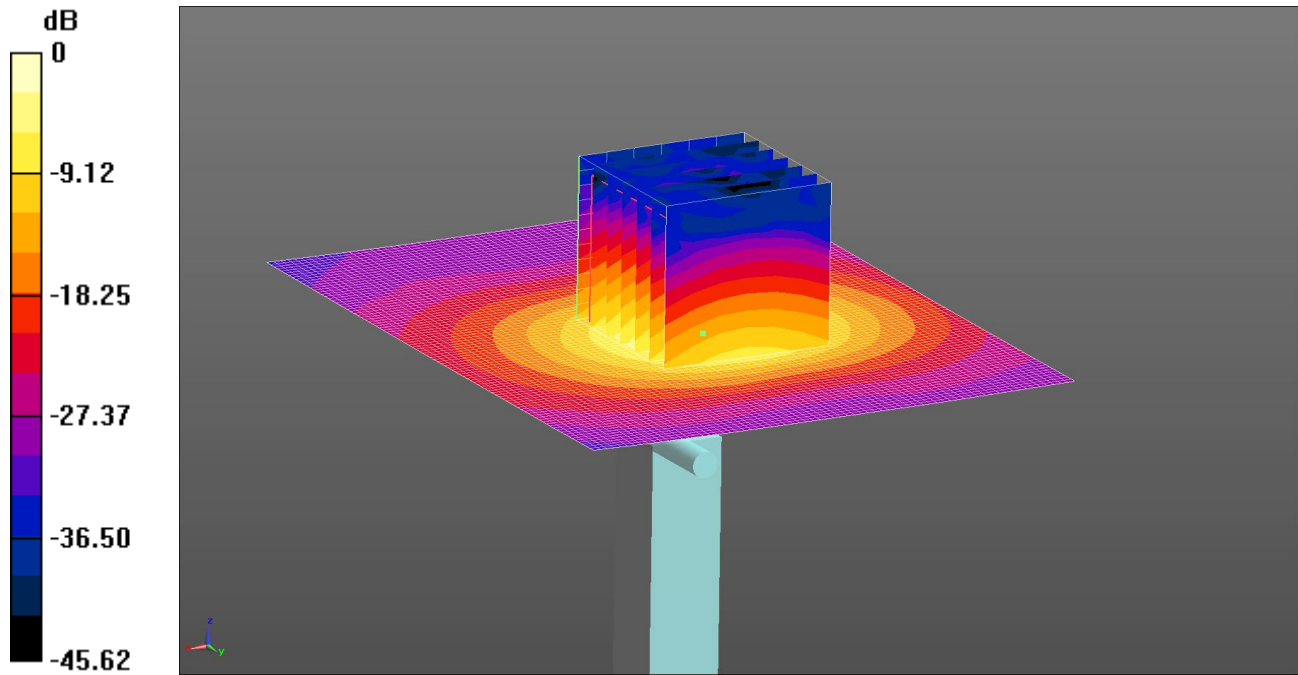

0 dB = 15.6 W/kg = 11.93 dBW/kg

Communication System: UID 0, CW (0); Frequency: 5250 MHz; Duty Cycle: 1:1

Medium: 5200/5500/5800 MHz MSL Medium parameters used: $f = 5250$ MHz; $\sigma = 5.337$ S/m; $\epsilon_r = 48.937$; $\rho = 1000$ kg/m³

Phantom section: Flat Section

DASY4 Configuration:

- Probe: EX3DV4 - SN3814; ConvF(4.38, 4.38, 4.38); Calibrated: 18/09/2014;
- Sensor-Surface: 2mm (Mechanical Surface Detection)
- Electronics: DAE4 Sn1435; Calibrated: 20/02/2015
- Phantom: ELI v5.0 (30deg probe tilt); Type: QDOVA002AA;
- ; SEMCAD X Version 14.6.10 (7164)

Configuration/d=10mm, Pin=100mW 2 2/Area Scan (71x91x1): Interpolated grid: dx=1.000 mm, dy=1.000 mm

Maximum value of SAR (interpolated) = 15.5 W/kg

Configuration/d=10mm, Pin=100mW 2 2/Zoom Scan (7x7x12) (7x7x12)/Cube 0: Measurement grid: dx=4mm, dy=4mm, dz=2mm

Reference Value = 35.373 V/m; Power Drift = 0.10 dB

Peak SAR (extrapolated) = 29.5 W/kg

SAR(1 g) = 7.43 W/kg; SAR(10 g) = 2.09 W/kg

Maximum value of SAR (measured) = 15.6 W/kg

014: System Performance Check 5600 MHz Body 01 07 15

Date: 01/07/2015

DUT: 5GHz Dipole; Type: D5GHzV2; Serial: SN 1016

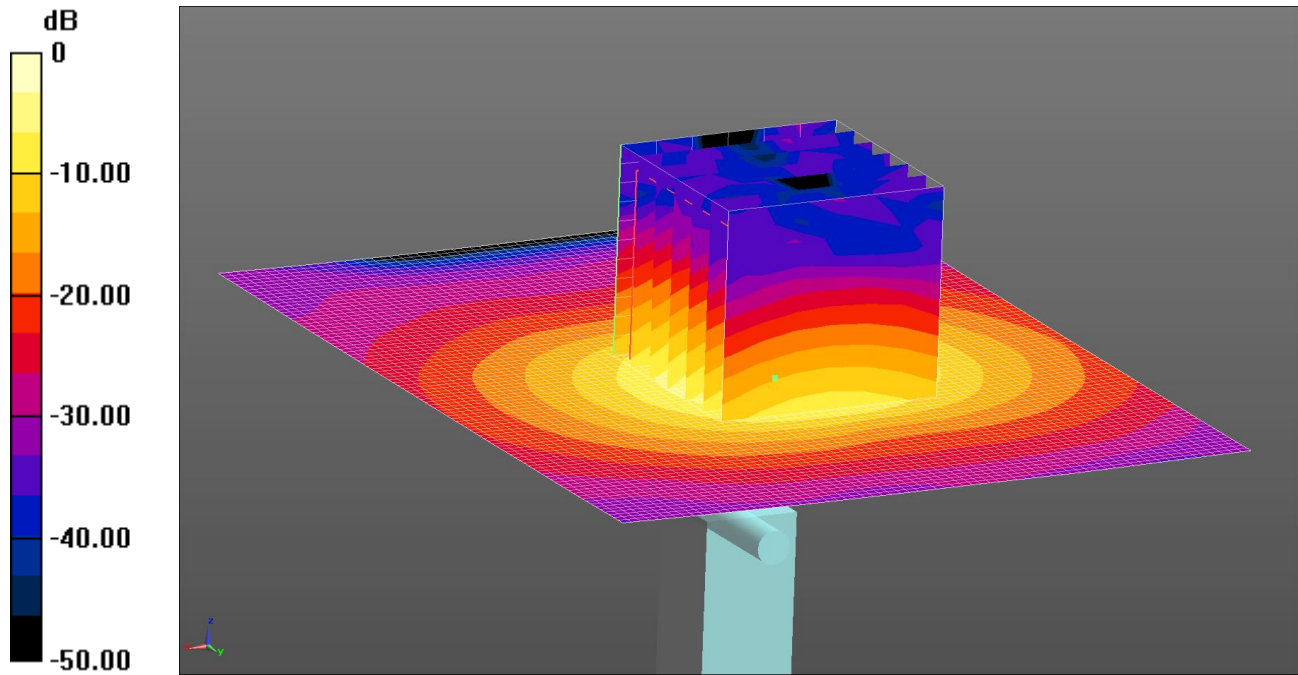

0 dB = 16.7 W/kg = 12.23 dBW/kg

Communication System: UID 0, CW (0); Frequency: 5600 MHz; Duty Cycle: 1:1

Medium: 5200/5500/5800 MHz MSL Medium parameters used: $f = 5600$ MHz; $\sigma = 5.855$ S/m; $\epsilon_r = 48.138$; $\rho = 1000$ kg/m³

Phantom section: Flat Section

DASY4 Configuration:

- Probe: EX3DV4 - SN3814; ConvF(3.79, 3.79, 3.79); Calibrated: 18/09/2014;
- Sensor-Surface: 2mm (Mechanical Surface Detection)
- Electronics: DAE4 Sn1435; Calibrated: 20/02/2015
- Phantom: ELI v5.0 (30deg probe tilt); Type: QDOVA002AA;
- ; SEMCAD X Version 14.6.10 (7164)

Configuration/d=10mm, Pin=100mW 2 2/Area Scan (71x91x1): Interpolated grid: dx=1.000 mm, dy=1.000 mm

Maximum value of SAR (interpolated) = 16.1 W/kg

Configuration/d=10mm, Pin=100mW 2 2/Zoom Scan (7x7x12) (7x7x12)/Cube 0: Measurement grid: dx=4mm, dy=4mm, dz=2mm

Reference Value = 33.645 V/m; Power Drift = 0.12 dB

Peak SAR (extrapolated) = 33.5 W/kg

SAR(1 g) = 7.76 W/kg; SAR(10 g) = 2.17 W/kg

Maximum value of SAR (measured) = 16.7 W/kg

015: System Performance Check 5600 MHz Body 13 07 15

Date: 13/07/15

DUT: 5GHz Dipole; Type: D5GHzV2; Serial: SN 1016

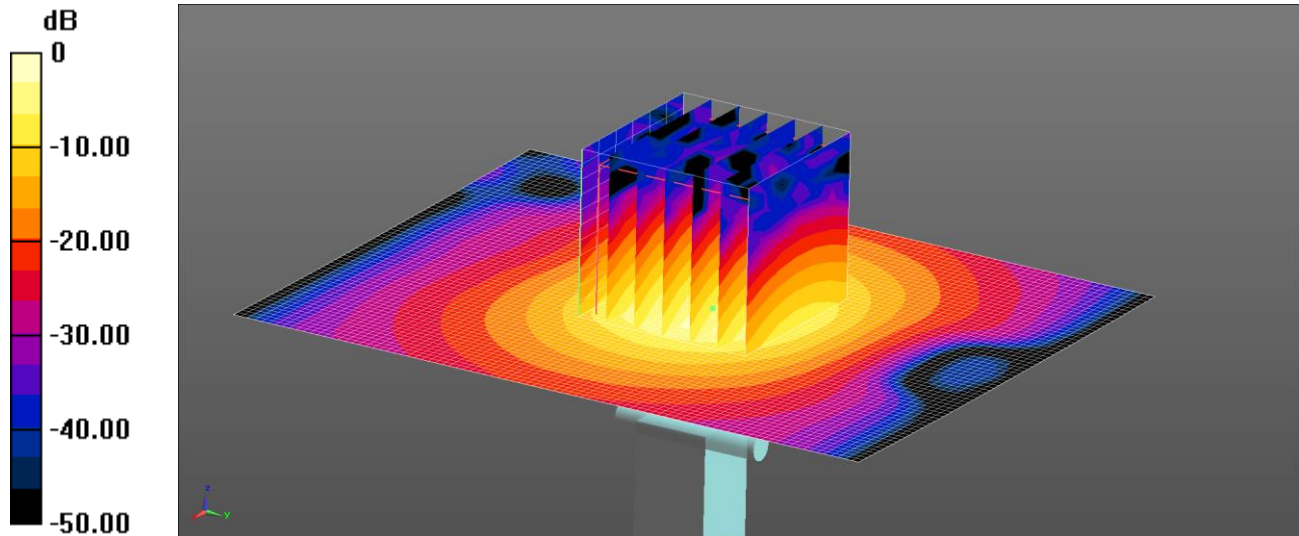

0 dB = 16.6 W/kg = 12.20 dBW/kg

Communication System: UID 0, CW (0); Frequency: 5600 MHz; Duty Cycle: 1:1

Medium: 5200/5500/5800 MHz MSL Medium parameters used: $f = 5600$ MHz; $\sigma = 5.911$ S/m; $\epsilon_r = 46.953$; $\rho = 1000$ kg/m³

Phantom section: Flat Section

DASY4 Configuration:

- Probe: EX3DV4 - SN3814; ConvF(3.79, 3.79, 3.79); Calibrated: 18/09/14;
- Sensor-Surface: 2mm (Mechanical Surface Detection)
- Electronics: DAE4 Sn1435; Calibrated: 20/02/15
- Phantom: ELI v5.0 (30deg probe tilt); Type: QDOVA002AA;
- ; SEMCAD X Version 14.6.10 (7331)

Configuration/d=10mm, Pin=100mW/Area Scan (71x91x1): Interpolated grid: dx=1.000 mm, dy=1.000 mm

Maximum value of SAR (interpolated) = 16.3 W/kg

Configuration/d=10mm, Pin=100mW/Zoom Scan (7x7x12) (7x7x12)/Cube 0: Measurement grid: dx=4mm, dy=4mm, dz=2mm

Reference Value = 38.16 V/m; Power Drift = 0.12 dB

Peak SAR (extrapolated) = 31.9 W/kg

SAR(1 g) = 7.72 W/kg; SAR(10 g) = 2.13 W/kg

Maximum value of SAR (measured) = 16.6 W/kg

016: System Performance Check 5750 MHz Body 01 07 15

Date: 01/07/2015

DUT: 5GHz Dipole; Type: D5GHzV2; Serial: SN 1016

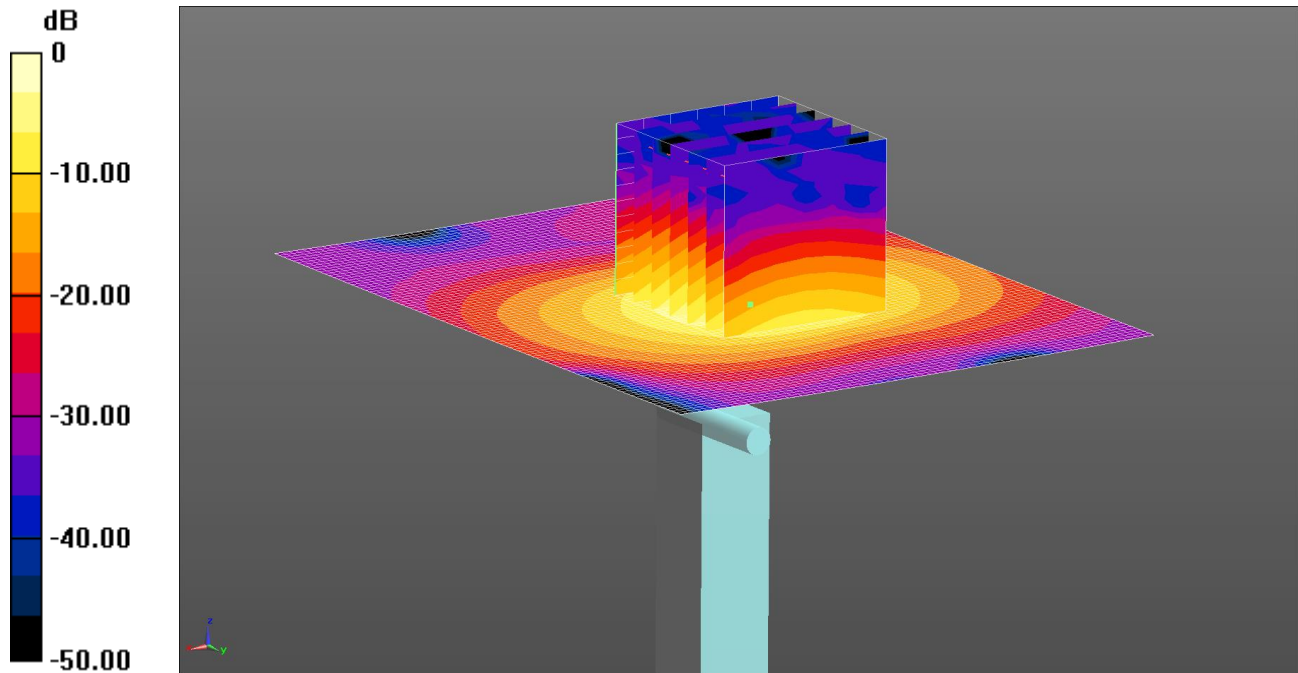

0 dB = 16.1 W/kg = 12.07 dBW/kg

Communication System: UID 0, CW (0); Frequency: 5750 MHz; Duty Cycle: 1:1

Medium: 5200/5500/5800 MHz MSL Medium parameters used: $f = 5750$ MHz; $\sigma = 6.043$ S/m; $\epsilon_r = 47.555$; $\rho = 1000$ kg/m³

Phantom section: Flat Section

DASY4 Configuration:

- Probe: EX3DV4 - SN3814; ConvF(4.06, 4.06, 4.06); Calibrated: 18/09/2014;
- Sensor-Surface: 2mm (Mechanical Surface Detection)
- Electronics: DAE4 Sn1435; Calibrated: 20/02/2015
- Phantom: ELI v5.0 (30deg probe tilt); Type: QDOVA002AA;
- ; SEMCAD X Version 14.6.10 (7164)

Configuration/d=10mm, Pin=100mW 2 2/Area Scan (71x91x1): Interpolated grid: dx=1.000 mm, dy=1.000 mm
Maximum value of SAR (interpolated) = 15.7 W/kg

Configuration/d=10mm, Pin=100mW 2 2/Zoom Scan (7x7x12) (7x7x12)/Cube 0: Measurement grid: dx=4mm, dy=4mm, dz=2mm

Reference Value = 32.560 V/m; Power Drift = 0.14 dB

Peak SAR (extrapolated) = 33.0 W/kg

SAR(1 g) = 7.45 W/kg; SAR(10 g) = 2.08 W/kg

Maximum value of SAR (measured) = 16.1 W/kg

017: System Performance Check 5750 MHz Body 06 07 15

Date: 06/07/15

DUT: 5GHz Dipole; Type: D5GHzV2; Serial: SN 1016

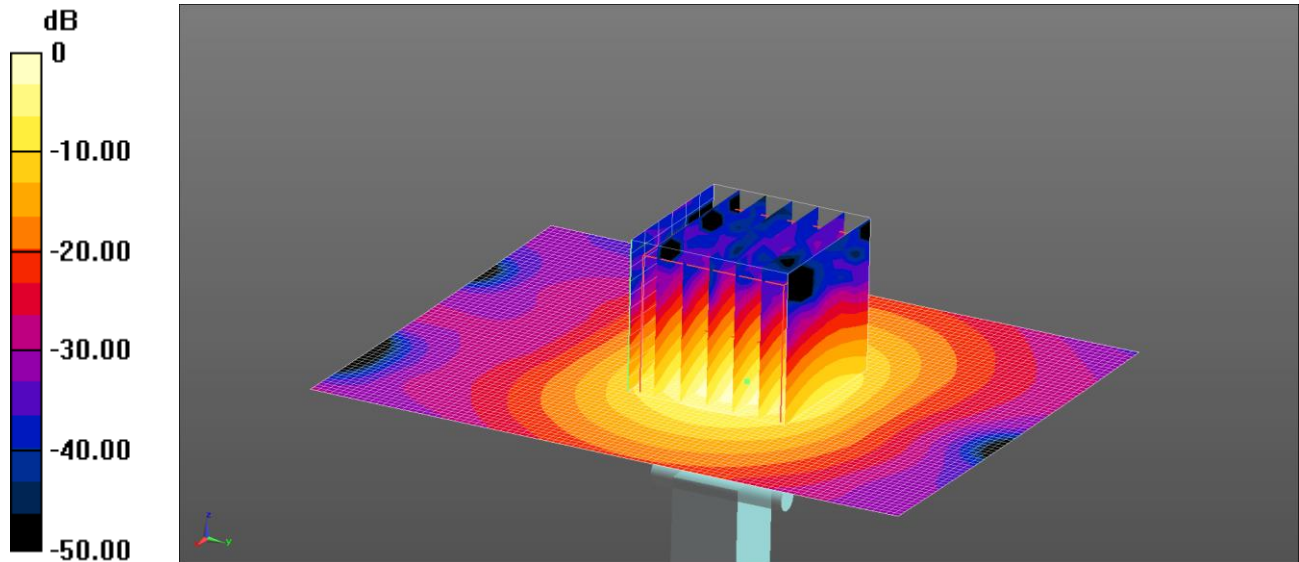

0 dB = 15.7 W/kg = 11.96 dBW/kg

Communication System: UID 0, CW (0); Frequency: 5750 MHz; Duty Cycle: 1:1

Medium: 5200/5500/5800 MHz MSL Medium parameters used: $f = 5750$ MHz; $\sigma = 6.158$ S/m; $\epsilon_r = 46.104$; $\rho = 1000$ kg/m³

Phantom section: Flat Section

DASY4 Configuration:

- Probe: EX3DV4 - SN3814; ConvF(4.06, 4.06, 4.06); Calibrated: 18/09/14;
- Sensor-Surface: 2mm (Mechanical Surface Detection)
- Electronics: DAE4 Sn1435; Calibrated: 20/02/15
- Phantom: ELI v5.0 (30deg probe tilt); Type: QDOVA002AA;
- ; SEMCAD X Version 14.6.10 (7331)

Configuration/d=10mm, Pin=100mW 2 2 /Area Scan (71x91x1): Interpolated grid: dx=1.000 mm, dy=1.000 mm

Maximum value of SAR (interpolated) = 15.8 W/kg

Configuration/d=10mm, Pin=100mW 2 2 /Zoom Scan (7x7x12) (7x7x12)/Cube 0: Measurement grid: dx=4mm, dy=4mm, dz=2mm

Reference Value = 34.30 V/m; Power Drift = -0.13 dB

Peak SAR (extrapolated) = 32.2 W/kg

SAR(1 g) = 7.39 W/kg; SAR(10 g) = 2.07 W/kg

Maximum value of SAR (measured) = 15.7 W/kg

12.3. SAR Test Plots

This appendix contains the following SAR distribution scans.

Scan Reference Number	Title
001	Back of EUT Facing Phantom GPRS 850 CH190
002	Top of EUT Facing Phantom GPRS 850 CH190
003	Left of EUT Facing Phantom GPRS 850 CH 190
004	Back of EUT Facing Phantom GPRS 850 CH128
005	Back of EUT Facing Phantom GPRS 850 CH251
006	Back of EUT Facing Phantom GPRS 850 CH190 Reduced Power
007	Top of EUT Facing Phantom GPRS 850 CH190 Reduced Power
008	Back of EUT Facing Phantom EDGE 850 CH190 Reduced Power
009	Top of EUT Facing Phantom EDGE 850 CH190 Reduced Power
010	Back of EUT Facing Phantom GPRS 1900 CH661
011	Top of EUT Facing Phantom GPRS 1900 CH661
012	Back of EUT Facing Phantom GPRS 1900 CH661 Reduced Power
013	Top of EUT Facing Phantom GPRS 1900 CH661 Reduced Power
014	Back of EUT Facing Phantom EDGE 1900 CH661 Reduced Power
015	Top of EUT Facing Phantom EDGE 1900 CH661 Reduced Power
016	Top of EUT Facing Phantom GPRS 1900 CH512 Reduced Power
017	Top of EUT Facing Phantom GPRS 1900 CH810 Reduced Power
018	Back Of EUT Facing Phantom WCDMA 2 CH9400
019	Back Of EUT Facing Phantom WCDMA 2 CH9262
020	Back Of EUT Facing Phantom WCDMA 2 CH9538
021	Top Of EUT Facing Phantom WCDMA 2 CH9400
022	Back Of EUT Facing Phantom WCDMA 2 CH9262 Reduced Power
023	Top Of EUT Facing Phantom WCDMA 2 CH9262 Reduced Power
024	Back Of EUT Facing Phantom WCDMA 2 CH9400 Reduced Power
025	Back Of EUT Facing Phantom WCDMA 2 CH9538 Reduced Power
026	Back of EUT Facing Phantom WCDMA FDD 4 CH1412
027	Top of EUT Facing Phantom WCDMA FDD 4 CH1412
028	Back of EUT Facing Phantom WCDMA FDD 4 CH1312
029	Back of EUT Facing Phantom WCDMA FDD 4 CH1513
030	Back of EUT Facing Phantom WCDMA FDD 4 CH1412 Reduced Power
031	Top of EUT Facing Phantom WCDMA FDD 4 CH1412 Reduced Power

Scan Reference Number	Title
032	Back of EUT Facing Phantom WCDMA FDD 5 CH4183
033	Top of EUT Facing Phantom WCDMA FDD 5 CH4183
034	Back of EUT Facing Phantom WCDMA FDD 5 CH4132
035	Back of EUT Facing Phantom WCDMA FDD 5 CH4233
036	Back of EUT Facing Phantom WCDMA FDD 5 CH4183 Reduced Power
037	Top of EUT Facing Phantom WCDMA FDD 5 CH 4183 Reduced Power
038	Back of EUT Facing Phantom CDMA BC0 CH384
039	Top of EUT Facing Phantom CDMA BC0 CH384
040	Back of EUT Facing Phantom CDMA BC0 CH1013
041	Back of EUT Facing Phantom CDMA BC0 CH777
042	Back of EUT Facing Phantom CDMA BC0 CH384 Reduced Power
043	Top of EUT Facing Phantom CDMA BC0 CH384 Reduced Power
044	Back of EUT Facing Phantom CDMA BC1 CH600
045	Top of EUT Facing Phantom CDMA BC1 CH600
046	Back of EUT Facing Phantom CDMA BC1 CH25
047	Back of EUT Facing Phantom CDMA BC1 CH1175
048	Back of EUT Facing Phantom CDMA BC1 CH1175 Reduced Power
049	Top of EUT Facing Phantom CDMA BC1 CH1175 Reduced Power
050	Back of EUT Facing Phantom CDMA BC10 CH580
051	Top of EUT Facing Phantom CDMA BC10 CH580
052	Back of EUT Facing Phantom CDMA BC10 CH476
053	Back of EUT Facing Phantom CDMA BC10 CH684
054	Back of EUT Facing Phantom CDMA BC10 CH580 Reduced Power
055	Top of EUT Facing Phantom CDMA BC10 CH580 Reduced Power
056	Back of EUT Facing Phantom LTE Band 2 1RB CH19100
057	Back of EUT Facing Phantom LTE Band 2 50%RB CH18900
058	Top of EUT Facing Phantom LTE Band 2 1RB CH19100
059	Top of EUT Facing Phantom LTE Band 2 50%RB CH18900
060	Back of EUT Facing Phantom LTE Band 2 1RB CH18700 Reduced Power
061	Back of EUT Facing Phantom LTE Band 2 50%RB CH18700 Reduced Power
062	Top of EUT Facing Phantom LTE Band 2 1RB CH18700 Reduced Power
063	Top of EUT Facing Phantom LTE Band 2 1RB CH18900 Reduced Power
064	Top of EUT Facing Phantom LTE Band 2 1RB CH19100 Reduced Power
065	Top of EUT Facing Phantom LTE Band 2 50%RB CH18700 Reduced Power

Scan Reference Number	Title
066	Back of EUT Facing Phantom LTE Band 4 1RB CH20050
067	Back of EUT Facing Phantom LTE Band 4 50%RB CH20175
068	Top of EUT Facing Phantom LTE Band 4 1RB CH20050
069	Top of EUT Facing Phantom LTE Band 4 50%RB CH20175
070	Back of EUT Facing Phantom LTE Band 4 1RB CH20175
071	Back of EUT Facing Phantom LTE Band 4 1RB CH20300
072	Back of EUT Facing Phantom LTE Band 4 1RB CH20050 Reduced Power
073	Back of EUT Facing Phantom LTE Band 4 50%RB CH20050 Reduced Power
074	Top of EUT Facing Phantom LTE Band 4 1RB CH20000 Reduced Power
075	Top of EUT Facing Phantom LTE Band 4 50%RB CH20050 Reduced Power
076	Back of EUT Facing Phantom LTE Band 5 1RB CH20525
077	Back of EUT Facing Phantom LTE Band 5 50%RB CH20450
078	Top of EUT Facing Phantom LTE Band 5 1RB CH20525
079	Top of EUT Facing Phantom LTE Band 5 50%RB CH20450
080	Back of EUT Facing Phantom LTE Band 5 1RB CH20450
081	Back of EUT Facing Phantom LTE Band 5 1RB CH20600
082	Back of EUT Facing Phantom LTE Band 5 1RB CH20450 Reduced Power
083	Back of EUT Facing Phantom LTE Band 5 50%RB CH20600 Reduced Power
084	Top of EUT Facing Phantom LTE Band 5 1RB CH20450 Reduced Power
085	Top of EUT Facing Phantom LTE Band 5 50%RB CH20600 Reduced Power
086	Back of EUT Facing Phantom LTE Band 13 1RB CH23230
087	Back of EUT Facing Phantom LTE Band 13 50%RB CH23230
088	Top of EUT Facing Phantom LTE Band 13 1RB CH23230
089	Top of EUT Facing Phantom LTE Band 13 50%RB CH23230
090	Back of EUT Facing Phantom LTE Band 13 1RB CH23230 Reduced Power
091	Back of EUT Facing Phantom LTE Band 13 50%RB CH23230 Reduced Power
092	Top of EUT Facing Phantom LTE Band 13 1RB CH23230 Reduced Power
093	Top of EUT Facing Phantom LTE Band 13 50%RB CH23230 Reduced Power
094	Back of EUT Facing Phantom LTE Band 17 1RB CH23790
095	Back of EUT Facing Phantom LTE Band 17 50%RB CH23790
096	Top of EUT Facing Phantom LTE Band 17 1RB CH23790
097	Top of EUT Facing Phantom LTE Band 17 50%RB CH23790
098	Back of EUT Facing Phantom LTE Band 17 1RB CH23790 Reduced Power
099	Back of EUT Facing Phantom LTE Band 17 50%RB CH23790 Reduced Power

Scan Reference Number	Title
100	Top of EUT Facing Phantom LTE Band 17 1RB CH23790 Reduced Power
101	Top of EUT Facing Phantom LTE Band 17 50%RB CH23790 Reduced Power
102	Back of EUT Facing Phantom LTE Band 17 1RB CH23780 Reduced Power
103	Back of EUT Facing Phantom LTE Band 17 1RB CH23800 Reduced Power
104	Back of EUT Facing Phantom LTE Band 25 1RB CH26590
105	Back of EUT Facing Phantom LTE Band 25 1RB CH26140
106	Back of EUT Facing Phantom LTE Band 25 1RB CH26365
107	Back of EUT Facing Phantom LTE Band 25 50%RB CH26140
108	Back of EUT Facing Phantom LTE Band 25 50%RB CH26365
109	Back of EUT Facing Phantom LTE Band 25 50%RB CH26590
110	Back of EUT Facing Phantom LTE Band 25 100%RB CH26140
111	Top of EUT Facing Phantom LTE Band 25 1RB CH26590
112	Top of EUT Facing Phantom LTE Band 25 50%RB CH26140
113	Back of EUT Facing Phantom LTE Band 25 1RB CH26590 Reduced Power
114	Back of EUT Facing Phantom LTE Band 25 1RB CH26140 Reduced Power
115	Back of EUT Facing Phantom LTE Band 25 1RB CH26365 Reduced Power
116	Back of EUT Facing Phantom LTE Band 25 50%RB CH26140 Reduced Power
117	Back of EUT Facing Phantom LTE Band 25 100%RB CH26590 Reduced Power
118	Top of EUT Facing Phantom LTE Band 25 1RB CH26590 Reduced Power
119	Top of EUT Facing Phantom LTE Band 25 1RB CH26140 Reduced Power
120	Top of EUT Facing Phantom LTE Band 25 1RB CH26365 Reduced Power
121	Top of EUT Facing Phantom LTE Band 25 50%RB CH26140 Reduced Power
122	Top of EUT Facing Phantom LTE Band 25 100%RB CH26590 Reduced Power
123	Back of EUT Facing Phantom WiFi 2.4GHz SISO Main CH6
124	Right of EUT Facing Phantom WiFi 2.4GHz SISO Main CH6
125	Back of EUT Facing Phantom WiFi 2.4GHz SISO Aux CH11
126	Right of EUT Facing Phantom WiFi 2.4GHz SISO Aux CH11
127	Back of EUT Facing Phantom WiFi 2.4GHz MIMO Main & Aux CH11
128	Right of EUT Facing Phantom WiFi 2.4GHz MIMO Main & Aux CH11
129	Back of EUT Facing Phantom WiFi 2.4GHz MIMO Main & Aux CH1
130	Back of EUT Facing Phantom WiFi 2.4GHz MIMO Main & Aux CH6
131	Back of EUT Facing Phantom Wi-Fi 5GHz 802.11a 6Mbps CH52 Wi-Fi Ant 1
132	Right of EUT Facing Phantom Wi-Fi 5GHz 802.11a 6Mbps CH52 Wi-Fi Ant 1

Scan Reference Number	Title
133	Back of EUT Facing Phantom Wi-Fi 5GHz 802.11a 6Mbps CH64 Wi-Fi Ant 2
134	Right of EUT Facing Phantom Wi-Fi 5GHz 802.11a 6Mbps CH64 Wi-Fi Ant 2
135	Back of EUT Facing Phantom Wi-Fi 5GHz 802.11a 6Mbps CH56 Wi-Fi Ant 1&2
136	Right of EUT Facing Phantom Wi-Fi 5GHz 802.11a 6Mbps CH56 Wi-Fi Ant 1&2
137	Right of EUT Facing Phantom Wi-Fi 5GHz 802.11a 6Mbps CH100 Wi-Fi Ant 1
138	Right of EUT Facing Phantom Wi-Fi 5GHz 802.11a 6Mbps CH104 Wi-Fi Ant 1
139	Back of EUT Facing Phantom Wi-Fi 5GHz 802.11a 6Mbps CH100 Wi-Fi Ant 2
140	Back of EUT Facing Phantom Wi-Fi 5GHz 802.11a 6Mbps CH100 Wi-Fi Ant 1&2
141	Right of EUT Facing Phantom Wi-Fi 5GHz 802.11a 6Mbps CH165 Wi-Fi Ant 1
142	Right of EUT Facing Phantom Wi-Fi 5GHz 802.11a 6Mbps CH149 Wi-Fi Ant 1
143	Back of EUT Facing Phantom Wi-Fi 5GHz 802.11a 6Mbps CH149 Wi-Fi Ant 2
144	Back of EUT Facing Phantom Wi-Fi 5GHz 802.11a 6Mbps CH153 Wi-Fi Ant 2
145	Back of EUT Facing Phantom Wi-Fi 5GHz 802.11a 6Mbps CH149 Wi-Fi Ant 1&2
146	Back of EUT Facing Phantom BT 2.4GHz SISO LE CH18
147	Right Hand Side of EUT Facing Phantom BT 2.4GHz SISO LE CH18
148	Right Hand Side of EUT Facing Phantom BT 2.4GHz SISO LE CH0
149	Right Hand Side of EUT Facing Phantom BT 2.4GHz SISO LE CH39

001: Back of EUT Facing Phantom GPRS 850 CH190

Date: 15/06/2015

DUT: Inari; Type: Tablet

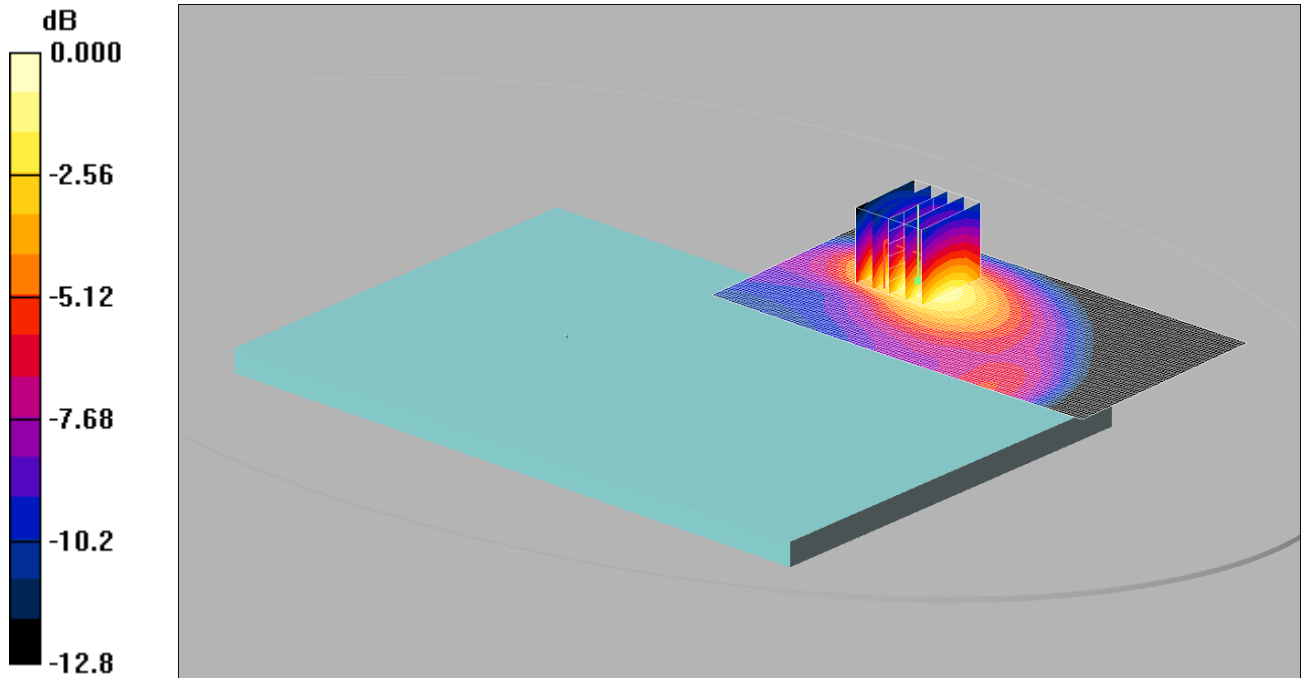

0 dB = 0.982mW/g

Communication System: GPRS 850 MHz 2TX; Frequency: 836.6 MHz; Duty Cycle: 1:4

Medium: 900 MHz MSL Medium parameters used (interpolated): $f = 836.6$ MHz; $\sigma = 1.01$ mho/m; $\epsilon_r = 53.9$; $\rho = 1000$ kg/m³

Phantom section: Flat Section

DASY4 Configuration:

- Probe: ES3DV3 - SN3304; ConvF(6.17, 6.17, 6.17);
- Sensor-Surface: 4mm (Mechanical Surface Detection)
- Electronics: DAE3 Sn432; Calibrated: 20/08/2014
- Phantom: ELI v5.0; Type: QDOVA002AA;
- Measurement SW: DASY4, V4.7 Build 80; Postprocessing SW: SEMCAD, V1.8 Build 186

Back of EUT Facing Phantom - Middle 2/Area Scan (61x121x1): Measurement grid: dx=15mm, dy=15mm

Maximum value of SAR (interpolated) = 0.960 mW/g

Back of EUT Facing Phantom - Middle 2/Zoom Scan (5x5x7) (5x5x7)/Cube 0: Measurement grid: dx=8mm, dy=8mm, dz=5mm

Reference Value = 6.96 V/m; Power Drift = 0.033 dB

Peak SAR (extrapolated) = 1.06 W/kg

SAR(1 g) = 0.818 mW/g; SAR(10 g) = 0.509 mW/g

Maximum value of SAR (measured) = 0.982 mW/g

002: Top of EUT Facing Phantom GPRS 850 CH190

Date: 15/06/2015

DUT: Inari; Type: Tablet

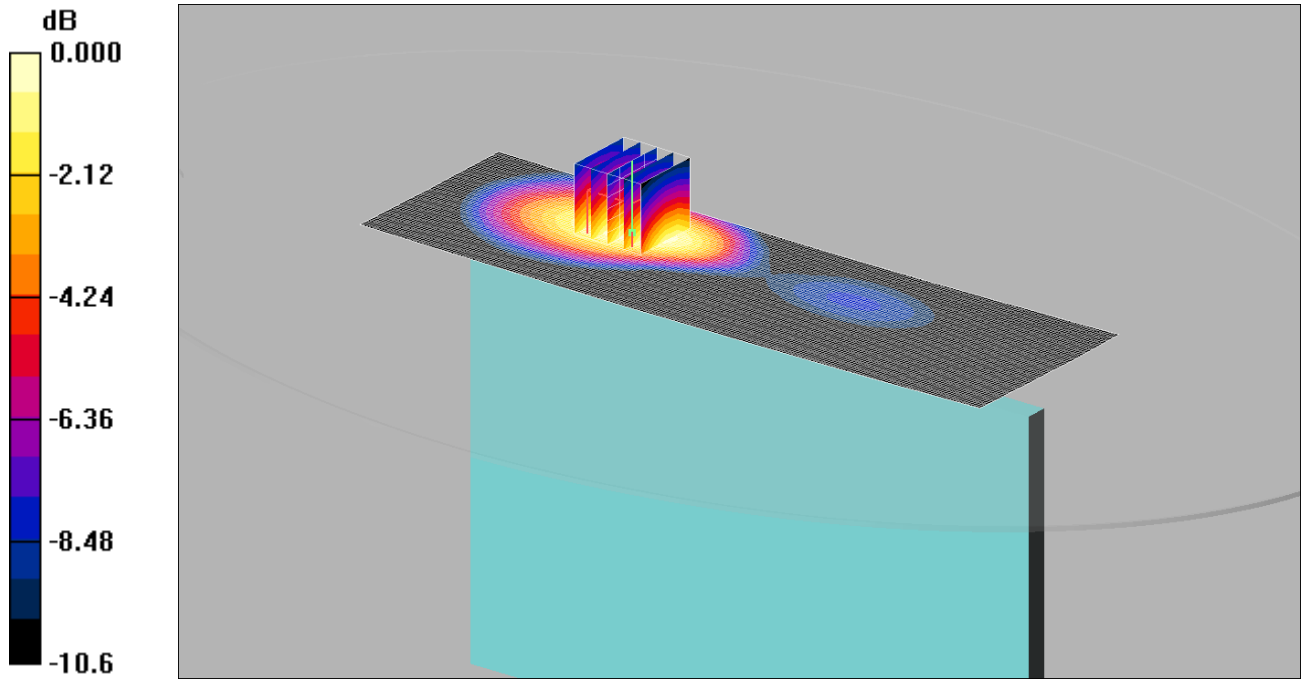

0 dB = 0.285mW/g

Communication System: GPRS 850 MHz 2TX; Frequency: 836.6 MHz; Duty Cycle: 1:4

Medium: 900 MHz MSL Medium parameters used (interpolated): $f = 836.6$ MHz; $\sigma = 1.01$ mho/m; $\epsilon_r = 53.9$; $\rho = 1000$ kg/m³

Phantom section: Flat Section

DASY4 Configuration:

- Probe: ES3DV3 - SN3304; ConvF(6.17, 6.17, 6.17);
- Sensor-Surface: 4mm (Mechanical Surface Detection)
- Electronics: DAE3 Sn432; Calibrated: 20/08/2014
- Phantom: ELI v5.0; Type: QDOVA002AA;
- Measurement SW: DASY4, V4.7 Build 80; Postprocessing SW: SEMCAD, V1.8 Build 186

Top of EUT Facing Phantom - Middle/Area Scan (61x201x1): Measurement grid: dx=15mm, dy=15mm

Maximum value of SAR (interpolated) = 0.287 mW/g

Top of EUT Facing Phantom - Middle/Zoom Scan (5x5x7) (5x5x7)/Cube 0: Measurement grid: dx=8mm, dy=8mm, dz=5mm

Reference Value = 13.1 V/m; Power Drift = 0.029 dB

Peak SAR (extrapolated) = 0.360 W/kg

SAR(1 g) = 0.263 mW/g; SAR(10 g) = 0.178 mW/g

Maximum value of SAR (measured) = 0.285 mW/g

003: Left of EUT Facing Phantom GPRS 850 CH 190

Date: 15/06/2015

DUT: Inari; Type: Tablet

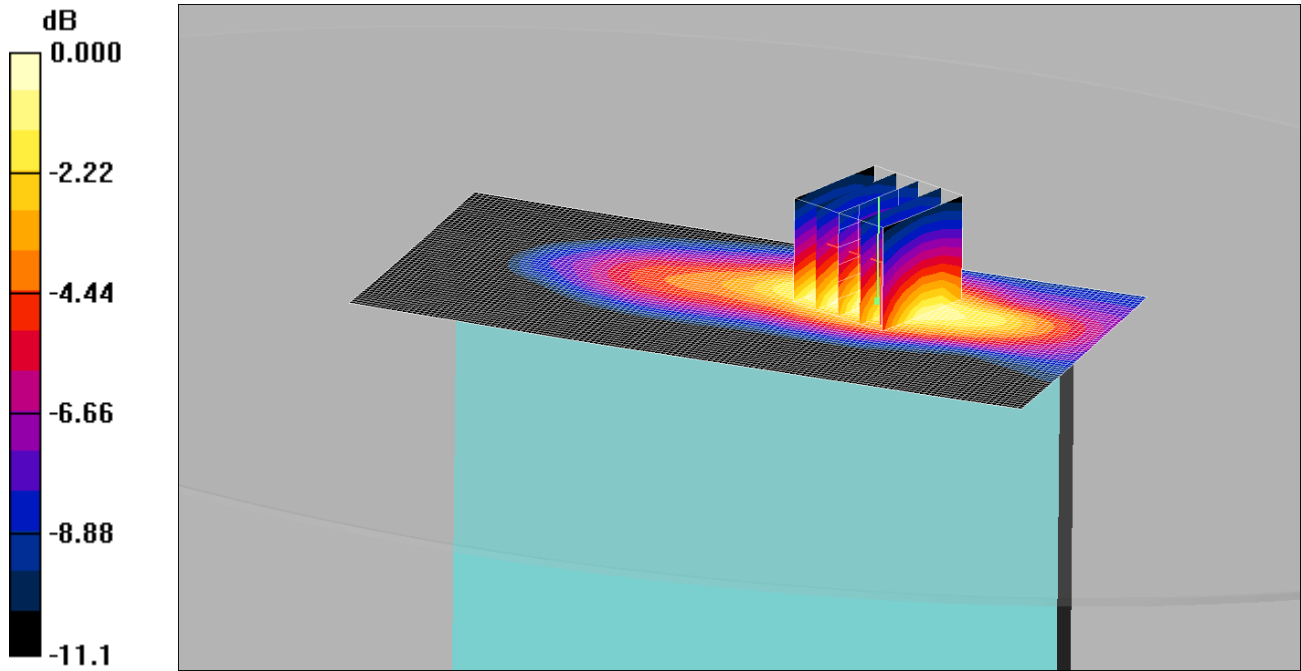

0 dB = 0.185mW/g

Communication System: GPRS 850 MHz 2TX; Frequency: 836.6 MHz; Duty Cycle: 1:4

Medium: 900 MHz MSL Medium parameters used (interpolated): $f = 836.6$ MHz; $\sigma = 1.01$ mho/m; $\epsilon_r = 53.9$; $\rho = 1000$ kg/m³

Phantom section: Flat Section

DASY4 Configuration:

- Probe: ES3DV3 - SN3304; ConvF(6.17, 6.17, 6.17);
- Sensor-Surface: 4mm (Mechanical Surface Detection)
- Electronics: DAE3 Sn432; Calibrated: 20/08/2014
- Phantom: ELI v5.0; Type: QDOVA002AA;
- Measurement SW: DASY4, V4.7 Build 80; Postprocessing SW: SEMCAD, V1.8 Build 186

Left of EUT Facing Phantom - Middle/Area Scan (61x131x1): Measurement grid: dx=15mm, dy=15mm

Maximum value of SAR (interpolated) = 0.194 mW/g

Left of EUT Facing Phantom - Middle/Zoom Scan (5x5x7) (5x5x7)/Cube 0: Measurement grid: dx=8mm, dy=8mm, dz=5mm

Reference Value = 10.9 V/m; Power Drift = 0.087 dB

Peak SAR (extrapolated) = 0.262 W/kg

SAR(1 g) = 0.171 mW/g; SAR(10 g) = 0.109 mW/g

Maximum value of SAR (measured) = 0.185 mW/g

004: Back of EUT Facing Phantom GPRS 850 CH128

Date: 15/06/2015

DUT: Inari; Type: Tablet

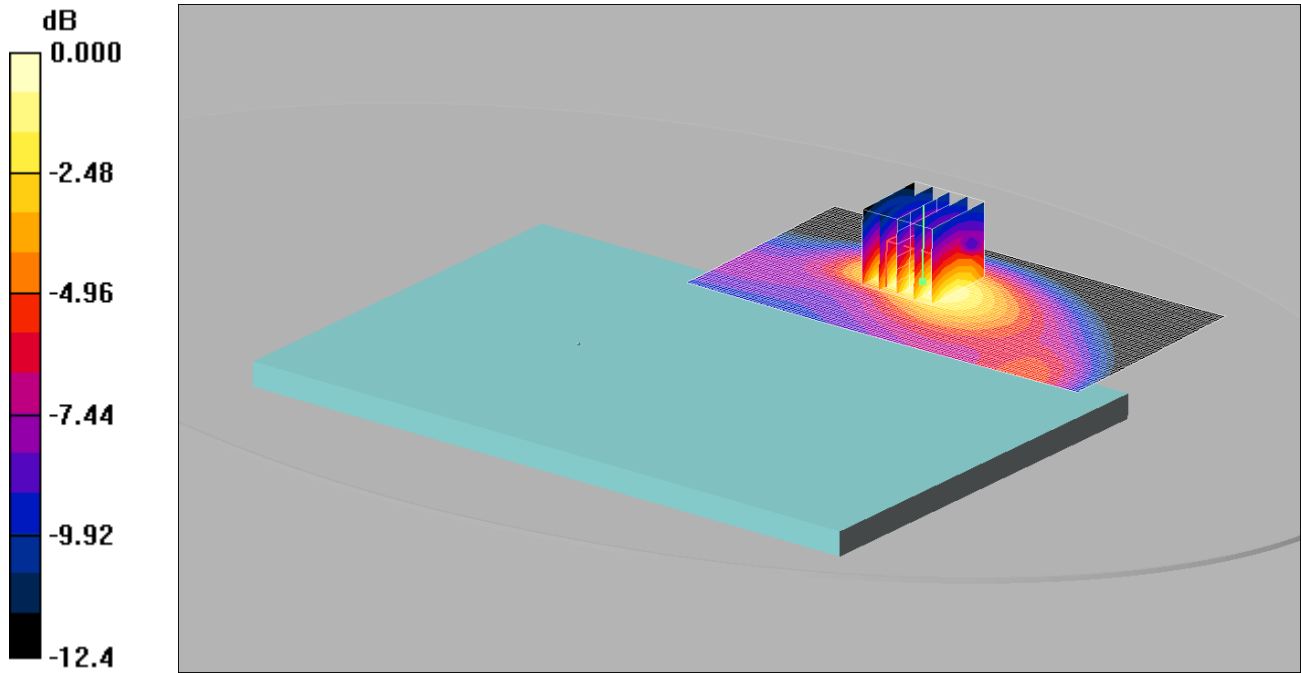

0 dB = 0.958mW/g

Communication System: GPRS 850 MHz 2TX; Frequency: 824.2 MHz; Duty Cycle: 1:4

Medium: 900 MHz MSL Medium parameters used (interpolated): $f = 824.2$ MHz; $\sigma = 1.01$ mho/m; $\epsilon_r = 54$; $\rho = 1000$ kg/m³

Phantom section: Flat Section

DASY4 Configuration:

- Probe: ES3DV3 - SN3304; ConvF(6.17, 6.17, 6.17);
- Sensor-Surface: 4mm (Mechanical Surface Detection)
- Electronics: DAE3 Sn432; Calibrated: 20/08/2014
- Phantom: ELI v5.0; Type: QDOVA002AA;
- Measurement SW: DASY4, V4.7 Build 80; Postprocessing SW: SEMCAD, V1.8 Build 186

Back of EUT Facing Phantom - Low/Area Scan (61x121x1): Measurement grid: dx=15mm, dy=15mm

Maximum value of SAR (interpolated) = 0.920 mW/g

Back of EUT Facing Phantom - Low/Zoom Scan (5x5x7) (5x5x7)/Cube 0: Measurement grid: dx=8mm, dy=8mm, dz=5mm

Reference Value = 7.93 V/m; Power Drift = 0.000 dB

Peak SAR (extrapolated) = 1.35 W/kg

SAR(1 g) = 0.868 mW/g; SAR(10 g) = 0.535 mW/g

Maximum value of SAR (measured) = 0.958 mW/g

005: Back of EUT Facing Phantom GPRS 850 CH251

Date: 15/06/2015

DUT: Inari; Type: Tablet

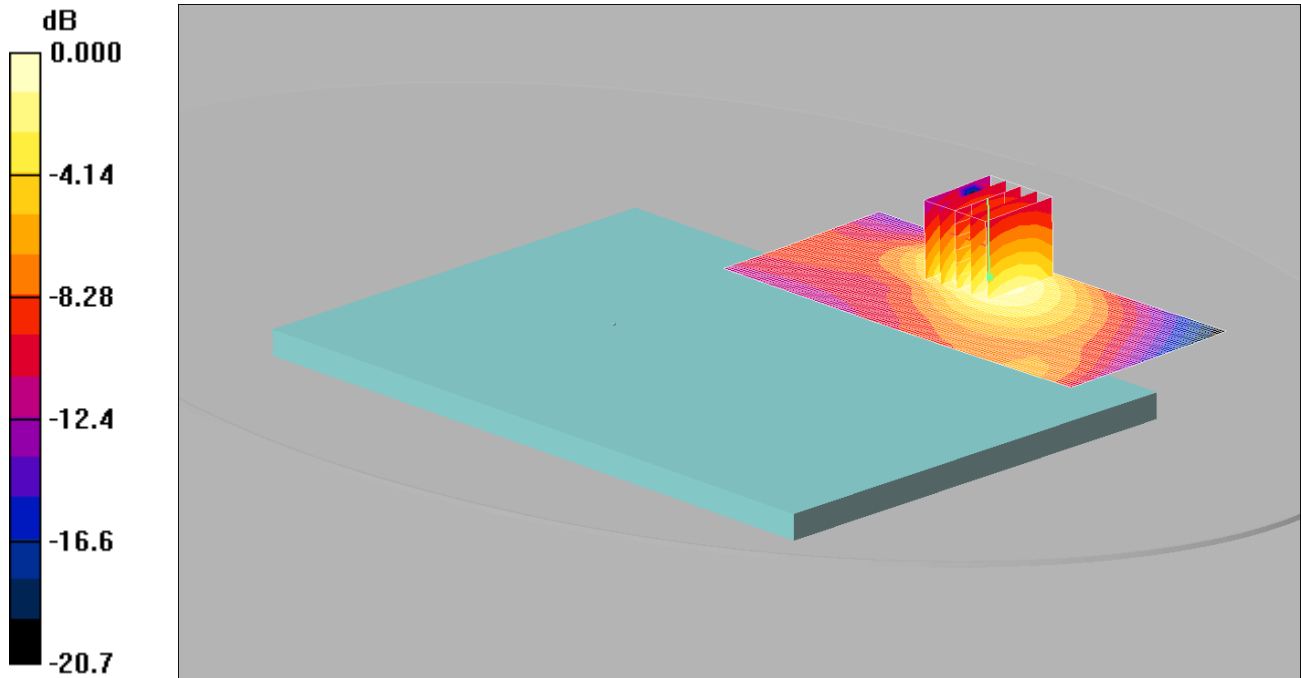

0 dB = 0.911mW/g

Communication System: GPRS 850 MHz 2TX; Frequency: 848.8 MHz; Duty Cycle: 1:4

Medium: 900 MHz MSL Medium parameters used (interpolated): $f = 848.8$ MHz; $\sigma = 1.02$ mho/m; $\epsilon_r = 53.9$; $\rho = 1000$ kg/m³

Phantom section: Flat Section

DASY4 Configuration:

- Probe: ES3DV3 - SN3304; ConvF(6.17, 6.17, 6.17);
- Sensor-Surface: 4mm (Mechanical Surface Detection)
- Electronics: DAE3 Sn432; Calibrated: 20/08/2014
- Phantom: ELI v5.0; Type: QDOVA002AA;
- Measurement SW: DASY4, V4.7 Build 80; Postprocessing SW: SEMCAD, V1.8 Build 186

Back of EUT Facing Phantom - High/Area Scan (51x121x1): Measurement grid: dx=15mm, dy=15mm

Maximum value of SAR (interpolated) = 0.913 mW/g

Back of EUT Facing Phantom - High/Zoom Scan (5x5x7) (5x5x7)/Cube 0: Measurement grid: dx=8mm, dy=8mm, dz=5mm

Reference Value = 9.64 V/m; Power Drift = 0.066 dB

Peak SAR (extrapolated) = 1.30 W/kg

SAR(1 g) = 0.834 mW/g; SAR(10 g) = 0.516 mW/g

Maximum value of SAR (measured) = 0.911 mW/g

006: Back of EUT Facing Phantom GPRS 850 CH190 Reduced Power

Date: 15/06/2015

DUT: Inari; Type: Tablet

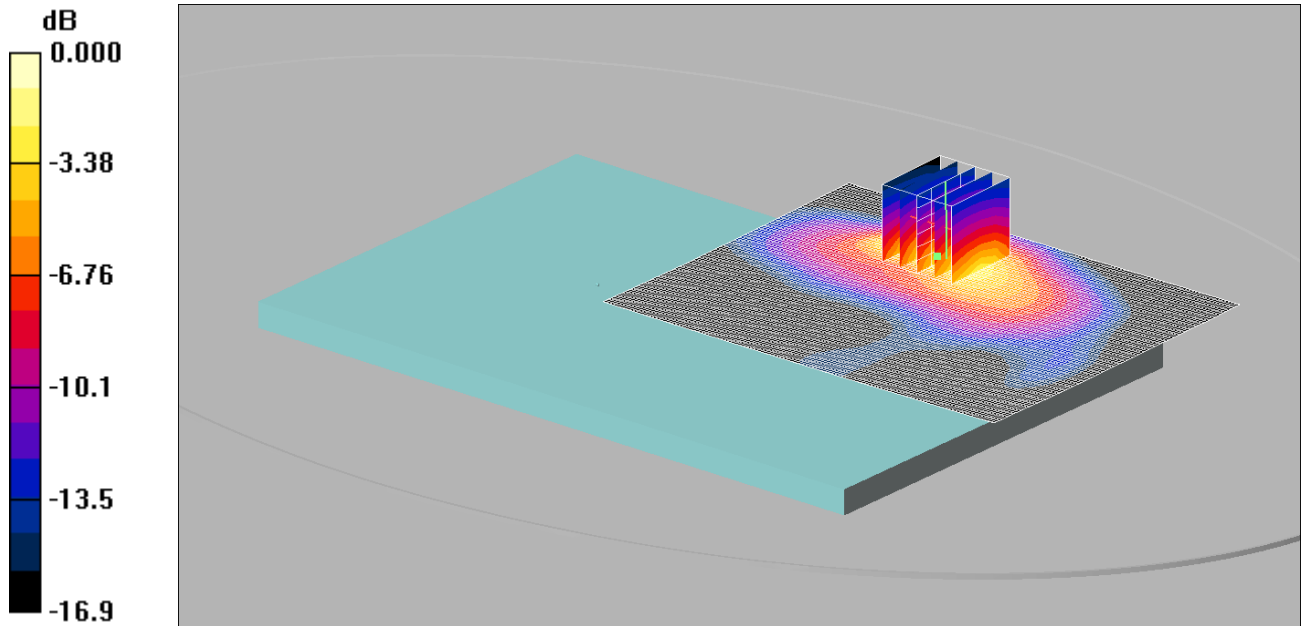

0 dB = 0.479mW/g

Communication System: GPRS 850 MHz 2TX; Frequency: 836.6 MHz; Duty Cycle: 1:4

Medium: 900 MHz MSL Medium parameters used (interpolated): $f = 836.6$ MHz; $\sigma = 1.01$ mho/m; $\epsilon_r = 53.9$; $\rho = 1000$ kg/m³

Phantom section: Flat Section

DASY4 Configuration:

- Probe: ES3DV3 - SN3304; ConvF(6.17, 6.17, 6.17);
- Sensor-Surface: 4mm (Mechanical Surface Detection)
- Electronics: DAE3 Sn432; Calibrated: 20/08/2014
- Phantom: ELI v5.0; Type: QDOVA002AA;
- Measurement SW: DASY4, V4.7 Build 80; Postprocessing SW: SEMCAD, V1.8 Build 186

Back of EUT Facing Phantom - Middle/Area Scan (91x121x1): Measurement grid: dx=15mm, dy=15mm

Maximum value of SAR (interpolated) = 0.479 mW/g

Back of EUT Facing Phantom - Middle/Zoom Scan (5x5x7) (5x5x7)/Cube 0: Measurement grid: dx=8mm, dy=8mm, dz=5mm

Reference Value = 9.63 V/m; Power Drift = -0.011 dB

Peak SAR (extrapolated) = 0.851 W/kg

SAR(1 g) = 0.392 mW/g; SAR(10 g) = 0.190 mW/g

Maximum value of SAR (measured) = 0.479 mW/g

007: Top of EUT Facing Phantom GPRS 850 CH190 Reduced Power

Date: 15/06/2015

DUT: Inari; Type: Tablet

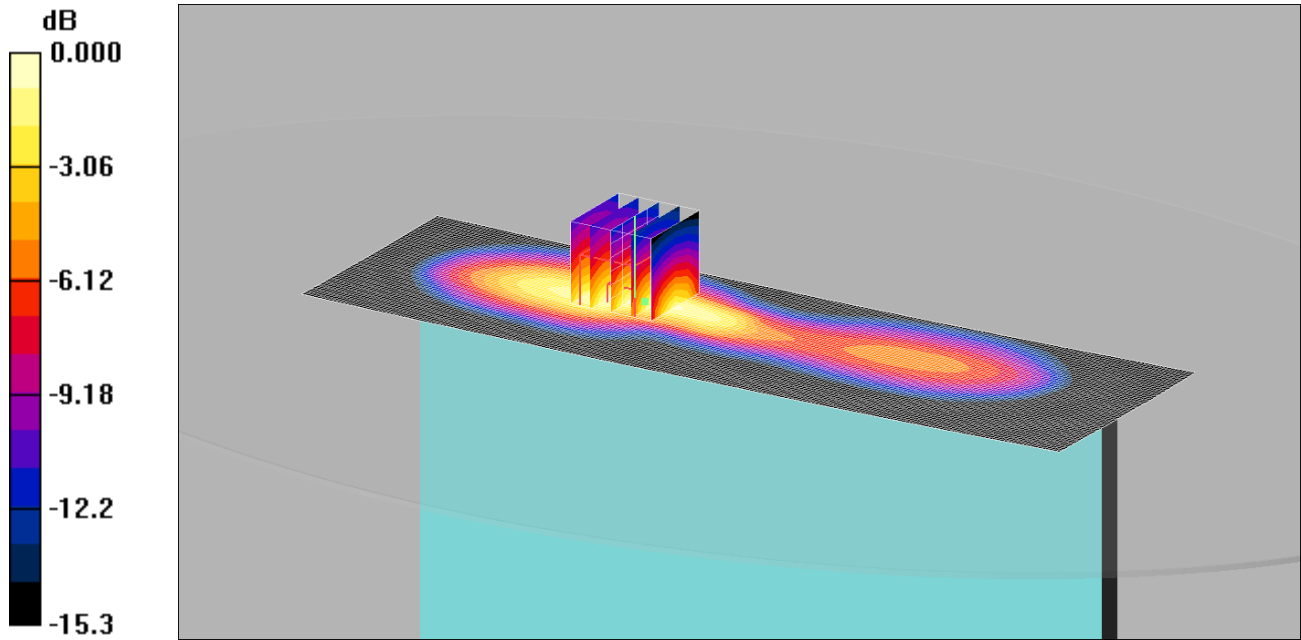

0 dB = 0.230mW/g

Communication System: GPRS 850 MHz 2TX; Frequency: 836.6 MHz; Duty Cycle: 1:4

Medium: 900 MHz MSL Medium parameters used (interpolated): $f = 836.6$ MHz; $\sigma = 1.01$ mho/m; $\epsilon_r = 53.9$; $\rho = 1000$ kg/m³

Phantom section: Flat Section

DASY4 Configuration:

- Probe: ES3DV3 - SN3304; ConvF(6.17, 6.17, 6.17);
- Sensor-Surface: 4mm (Mechanical Surface Detection)
- Electronics: DAE3 Sn432; Calibrated: 20/08/2014
- Phantom: ELI v5.0; Type: QDOVA002AA;
- Measurement SW: DASY4, V4.7 Build 80; Postprocessing SW: SEMCAD, V1.8 Build 186

Top of EUT Facing Phantom - Middle/Area Scan (61x201x1): Measurement grid: dx=15mm, dy=15mm

Maximum value of SAR (interpolated) = 0.209 mW/g

Top of EUT Facing Phantom - Middle/Zoom Scan (5x5x7) (5x5x7)/Cube 0: Measurement grid: dx=8mm, dy=8mm, dz=5mm

Reference Value = 9.71 V/m; Power Drift = 0.102 dB

Peak SAR (extrapolated) = 0.380 W/kg

SAR(1 g) = 0.203 mW/g; SAR(10 g) = 0.111 mW/g

Maximum value of SAR (measured) = 0.230 mW/g

008: Back of EUT Facing Phantom EDGE 850 CH190 Reduced Power

Date: 15/06/2015

DUT: Inari; Type: Tablet

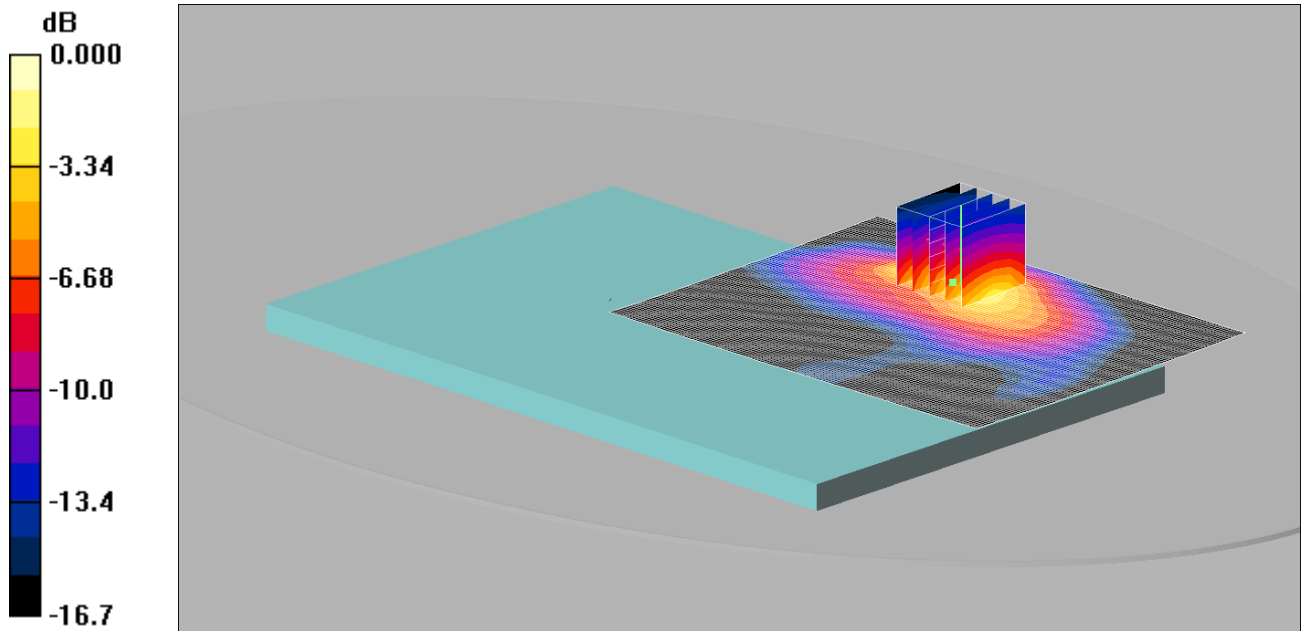

0 dB = 0.472mW/g

Communication System: GPRS 850 MHz 2TX; Frequency: 836.6 MHz; Duty Cycle: 1:4

Medium: 900 MHz MSL Medium parameters used (interpolated): $f = 836.6$ MHz; $\sigma = 1.01$ mho/m; $\epsilon_r = 53.9$; $\rho = 1000$ kg/m³

Phantom section: Flat Section

DASY4 Configuration:

- Probe: ES3DV3 - SN3304; ConvF(6.17, 6.17, 6.17);
- Sensor-Surface: 4mm (Mechanical Surface Detection)
- Electronics: DAE3 Sn432; Calibrated: 20/08/2014
- Phantom: ELI v5.0; Type: QDOVA002AA;
- Measurement SW: DASY4, V4.7 Build 80; Postprocessing SW: SEMCAD, V1.8 Build 186

Back of EUT Facing Phantom - Middle/Area Scan (91x121x1): Measurement grid: dx=15mm, dy=15mm

Maximum value of SAR (interpolated) = 0.476 mW/g

Back of EUT Facing Phantom - Middle/Zoom Scan (5x5x7) (5x5x7)/Cube 0: Measurement grid: dx=8mm, dy=8mm, dz=5mm

Reference Value = 2.36 V/m; Power Drift = 0.142 dB

Peak SAR (extrapolated) = 0.824 W/kg

SAR(1 g) = 0.387 mW/g; SAR(10 g) = 0.189 mW/g

Maximum value of SAR (measured) = 0.472 mW/g

009: Top of EUT Facing Phantom EDGE 850 CH190 Reduced Power

Date: 15/06/2015

DUT: Inari; Type: Tablet

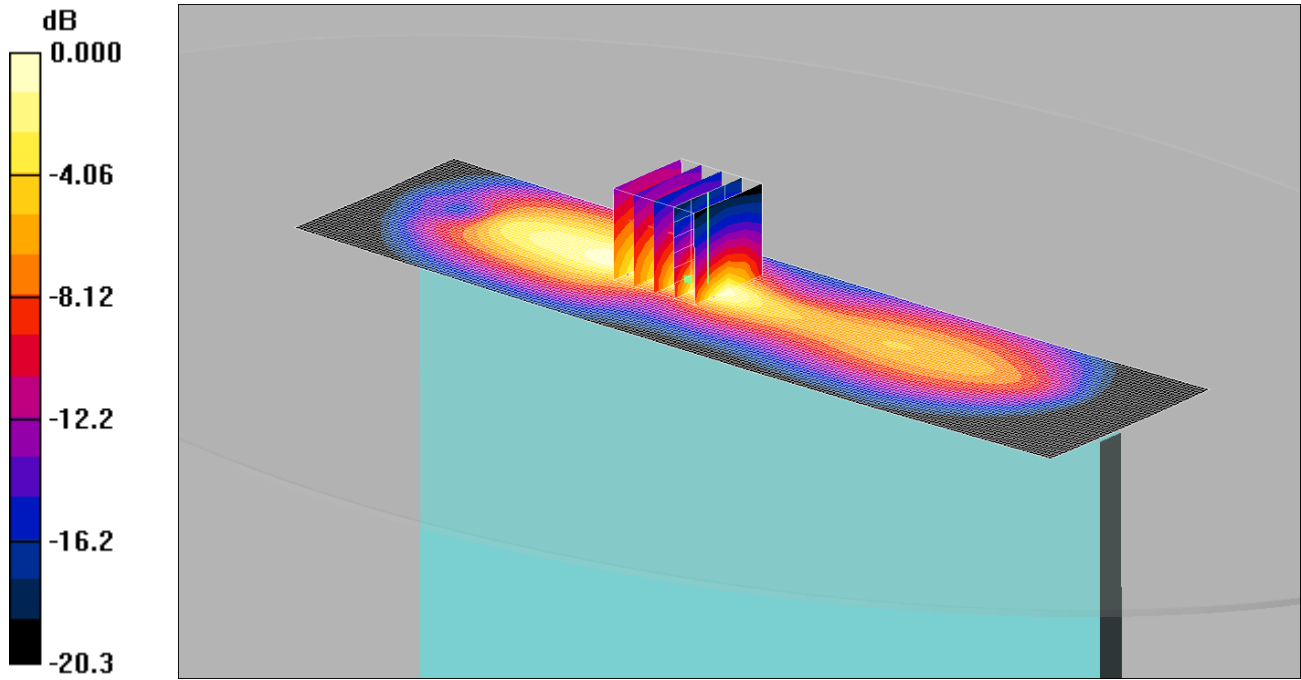

0 dB = 0.246mW/g

Communication System: GPRS 850 MHz 2TX; Frequency: 836.6 MHz; Duty Cycle: 1:4

Medium: 900 MHz MSL Medium parameters used (interpolated): $f = 836.6$ MHz; $\sigma = 1.01$ mho/m; $\epsilon_r = 53.9$; $\rho = 1000$ kg/m³

Phantom section: Flat Section

DASY4 Configuration:

- Probe: ES3DV3 - SN3304; ConvF(6.17, 6.17, 6.17);
- Sensor-Surface: 4mm (Mechanical Surface Detection)
- Electronics: DAE3 Sn432; Calibrated: 20/08/2014
- Phantom: ELI v5.0; Type: QDOVA002AA;
- Measurement SW: DASY4, V4.7 Build 80; Postprocessing SW: SEMCAD, V1.8 Build 186

Top of EUT Facing Phantom - Middle/Area Scan (51x201x1): Measurement grid: dx=15mm, dy=15mm

Maximum value of SAR (interpolated) = 0.236 mW/g

Top of EUT Facing Phantom - Middle/Zoom Scan (5x5x7) (5x5x7)/Cube 0: Measurement grid: dx=8mm, dy=8mm, dz=5mm

Reference Value = 8.39 V/m; Power Drift = -0.034 dB

Peak SAR (extrapolated) = 0.615 W/kg

SAR(1 g) = 0.206 mW/g; SAR(10 g) = 0.095 mW/g

Maximum value of SAR (measured) = 0.246 mW/g

010: Back of EUT Facing Phantom GPRS 1900 CH661

Date: 24/06/2015

DUT: Inari; Type: Tablet

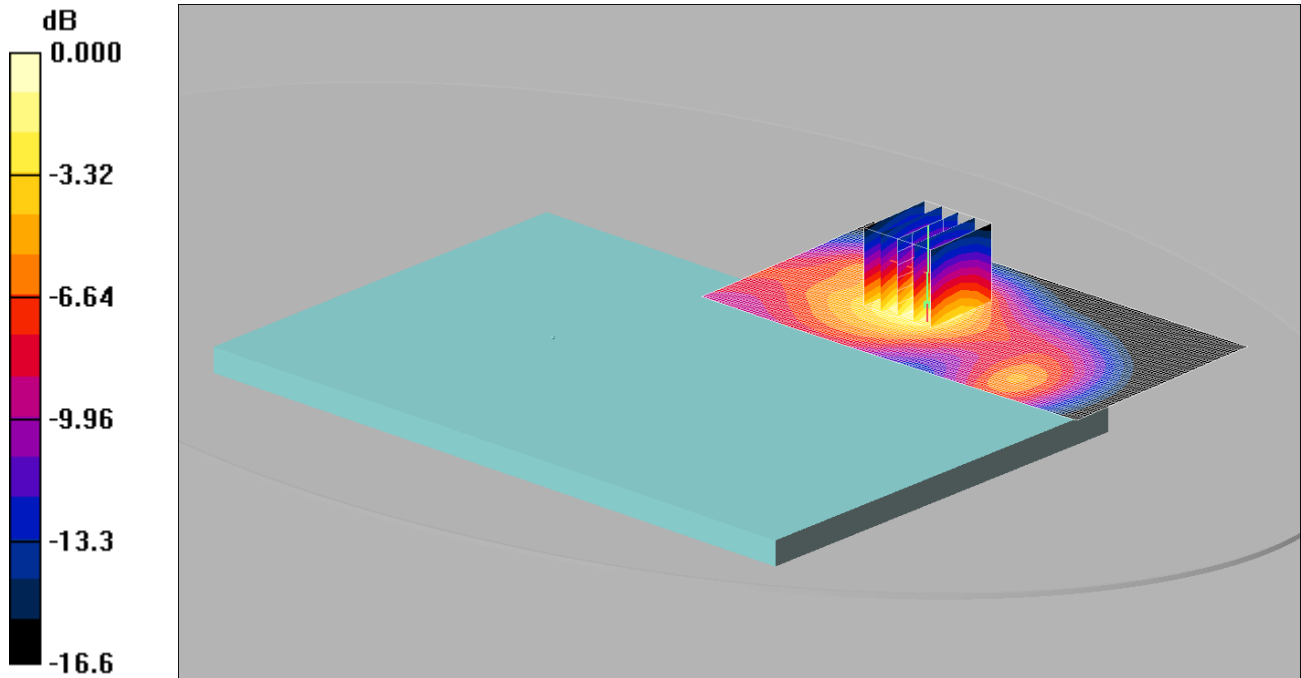

0 dB = 0.633mW/g

Communication System: GPRS 1900 2Tx; Frequency: 1880 MHz; Duty Cycle: 1:4

Medium: 1900 MHz MSL Medium parameters used (interpolated): $f = 1880$ MHz; $\sigma = 1.47$ mho/m; $\epsilon_r = 52.5$; $\rho = 1000$ kg/m³

Phantom section: Flat Section

DASY4 Configuration:

- Probe: ES3DV3 - SN3304; ConvF(4.69, 4.69, 4.69);
- Sensor-Surface: 4mm (Mechanical Surface Detection)
- Electronics: DAE3 Sn432; Calibrated: 20/08/2014
- Phantom: ELI v5.0; Type: QDOVA002AA;
- Measurement SW: DASY4, V4.7 Build 80; Postprocessing SW: SEMCAD, V1.8 Build 186

Back of EUT Facing Phantom - Middle/Area Scan (61x121x1): Measurement grid: dx=15mm, dy=15mm

Maximum value of SAR (interpolated) = 0.608 mW/g

Back of EUT Facing Phantom - Middle/Zoom Scan (5x5x7) (5x5x7)/Cube 0: Measurement grid: dx=8mm, dy=8mm, dz=5mm

Reference Value = 6.58 V/m; Power Drift = -0.024 dB

Peak SAR (extrapolated) = 0.980 W/kg

SAR(1 g) = 0.575 mW/g; SAR(10 g) = 0.322 mW/g

Maximum value of SAR (measured) = 0.633 mW/g

011: Top of EUT Facing Phantom GPRS 1900 CH661

Date: 24/06/2015

DUT: Inari; Type: Tablet

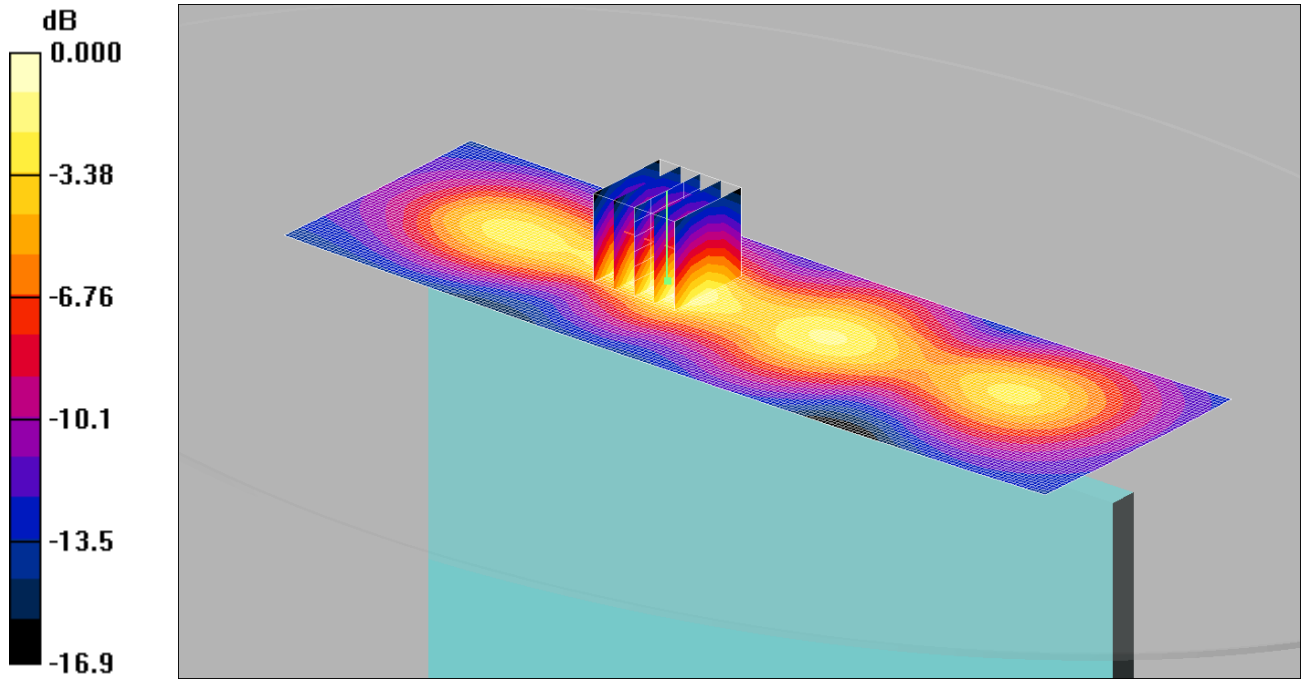

0 dB = 0.463mW/g

Communication System: GPRS 1900 2Tx; Frequency: 1880 MHz; Duty Cycle: 1:4

Medium: 1900 MHz MSL Medium parameters used (interpolated): $f = 1880$ MHz; $\sigma = 1.47$ mho/m; $\epsilon_r = 52.5$; $\rho = 1000$ kg/m³

Phantom section: Flat Section

DASY4 Configuration:

- Probe: ES3DV3 - SN3304; ConvF(4.69, 4.69, 4.69);
- Sensor-Surface: 4mm (Mechanical Surface Detection)
- Electronics: DAE3 Sn432; Calibrated: 20/08/2014
- Phantom: ELI v5.0; Type: QDOVA002AA;
- Measurement SW: DASY4, V4.7 Build 80; Postprocessing SW: SEMCAD, V1.8 Build 186

Top of EUT Facing Phantom - Middle/Area Scan (61x201x1): Measurement grid: dx=15mm, dy=15mm

Maximum value of SAR (interpolated) = 0.458 mW/g

Top of EUT Facing Phantom - Middle/Zoom Scan (5x5x7) (5x5x7)/Cube 0: Measurement grid: dx=8mm, dy=8mm, dz=5mm

Reference Value = 8.40 V/m; Power Drift = -0.017 dB

Peak SAR (extrapolated) = 0.698 W/kg

SAR(1 g) = 0.413 mW/g; SAR(10 g) = 0.231 mW/g

Maximum value of SAR (measured) = 0.463 mW/g

012: Back of EUT Facing Phantom GPRS 1900 CH661 Reduced Power

Date: 24/06/2015

DUT: Inari; Type: Tablet

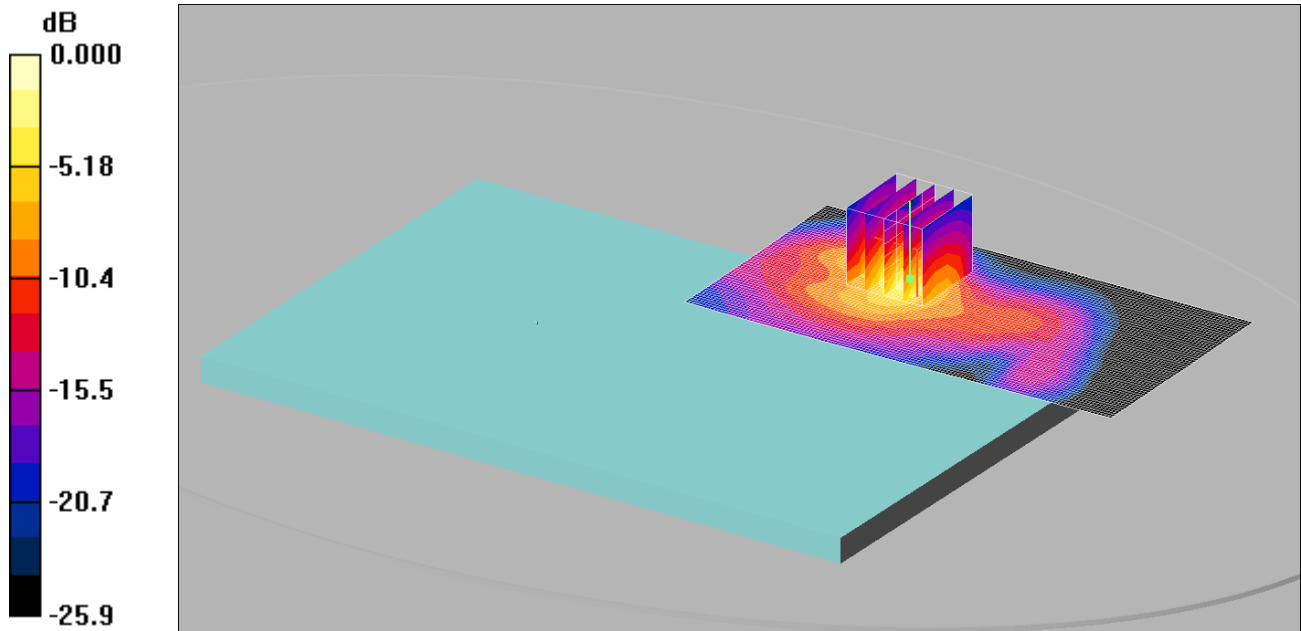

0 dB = 0.510mW/g

Communication System: GPRS 1900 2Tx; Frequency: 1880 MHz; Duty Cycle: 1:4

Medium: 1900 MHz MSL Medium parameters used (interpolated): $f = 1880$ MHz; $\sigma = 1.47$ mho/m; $\epsilon_r = 52.5$; $\rho = 1000$ kg/m³

Phantom section: Flat Section

DASY4 Configuration:

- Probe: ES3DV3 - SN3304; ConvF(4.69, 4.69, 4.69);
- Sensor-Surface: 4mm (Mechanical Surface Detection)
- Electronics: DAE3 Sn432; Calibrated: 20/08/2014
- Phantom: ELI v5.0; Type: QDOVA002AA;
- Measurement SW: DASY4, V4.7 Build 80; Postprocessing SW: SEMCAD, V1.8 Build 186

Back of EUT Facing Phantom - Middle/Area Scan (61x121x1): Measurement grid: dx=15mm, dy=15mm

Maximum value of SAR (interpolated) = 0.563 mW/g

Back of EUT Facing Phantom - Middle/Zoom Scan (5x5x7) (5x5x7)/Cube 0: Measurement grid: dx=8mm, dy=8mm, dz=5mm

Reference Value = 7.64 V/m; Power Drift = -0.002 dB

Peak SAR (extrapolated) = 0.964 W/kg

SAR(1 g) = 0.430 mW/g; SAR(10 g) = 0.184 mW/g

Maximum value of SAR (measured) = 0.510 mW/g

013: Top of EUT Facing Phantom GPRS 1900 CH661 Reduced Power

Date: 24/06/2015

DUT: Inari; Type: Tablet

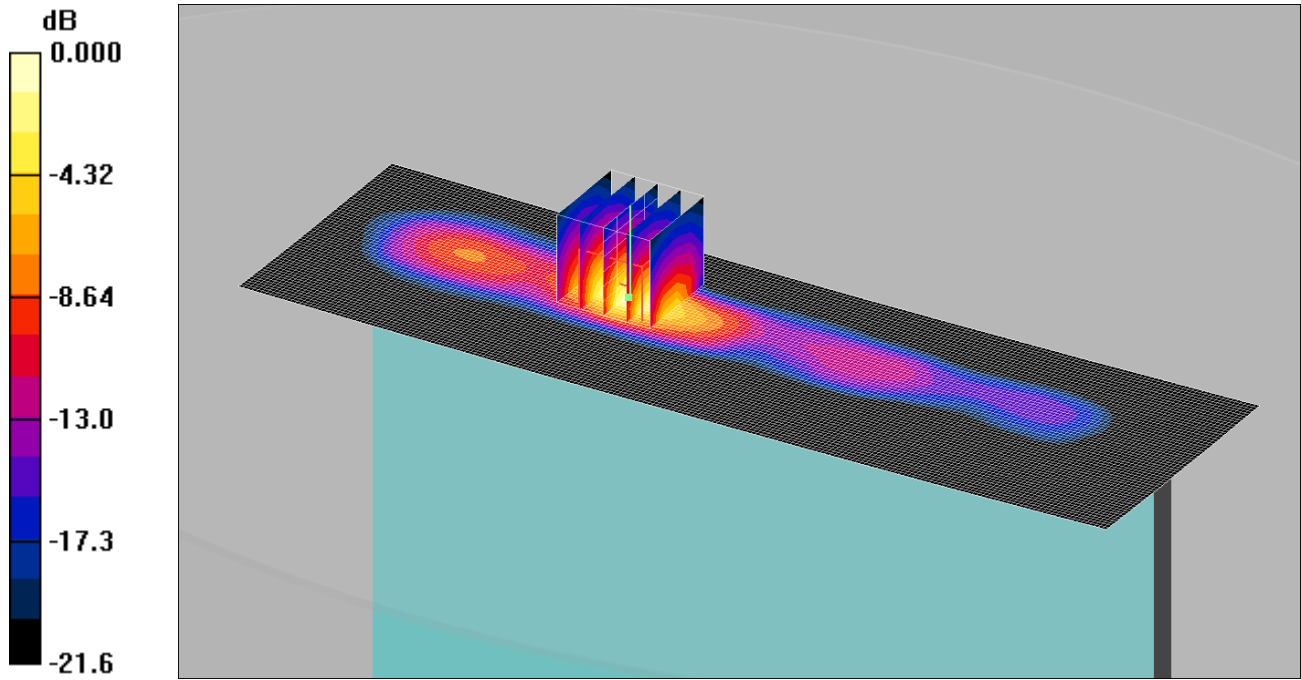

0 dB = 0.607mW/g

Communication System: GPRS 1900 2Tx; Frequency: 1880 MHz; Duty Cycle: 1:4

Medium: 1900 MHz MSL Medium parameters used (interpolated): $f = 1880$ MHz; $\sigma = 1.47$ mho/m; $\epsilon_r = 52.5$; $\rho = 1000$ kg/m³

Phantom section: Flat Section

DASY4 Configuration:

- Probe: ES3DV3 - SN3304; ConvF(4.69, 4.69, 4.69);
- Sensor-Surface: 4mm (Mechanical Surface Detection)
- Electronics: DAE3 Sn432; Calibrated: 20/08/2014
- Phantom: ELI v5.0; Type: QDOVA002AA;
- Measurement SW: DASY4, V4.7 Build 80; Postprocessing SW: SEMCAD, V1.8 Build 186

Top of EUT Facing Phantom - Middle/Area Scan (61x201x1): Measurement grid: dx=15mm, dy=15mm

Maximum value of SAR (interpolated) = 0.590 mW/g

Top of EUT Facing Phantom - Middle/Zoom Scan (5x5x7) (5x5x7)/Cube 0: Measurement grid: dx=8mm, dy=8mm, dz=5mm

Reference Value = 4.37 V/m; Power Drift = 0.003 dB

Peak SAR (extrapolated) = 1.27 W/kg

SAR(1 g) = 0.544 mW/g; SAR(10 g) = 0.226 mW/g

Maximum value of SAR (measured) = 0.607 mW/g

014: Back of EUT Facing Phantom EDGE 1900 CH661 Reduced Power

Date: 25/06/2015

DUT: Inari; Type: Tablet

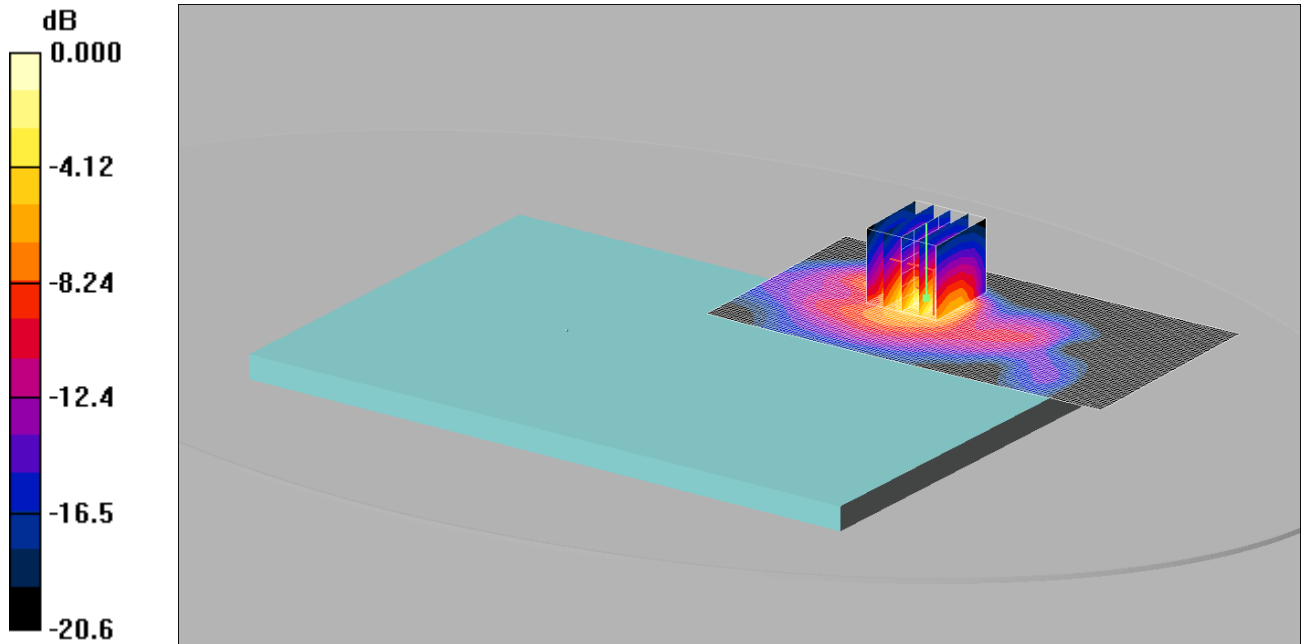

0 dB = 0.489mW/g

Communication System: EGPRS 1900 2Tx; Frequency: 1880 MHz; Duty Cycle: 1:4

Medium: 1900 MHz MSL Medium parameters used (interpolated): $f = 1880$ MHz; $\sigma = 1.47$ mho/m; $\epsilon_r = 52.5$; $\rho = 1000$ kg/m³

Phantom section: Flat Section

DASY4 Configuration:

- Probe: ES3DV3 - SN3304; ConvF(4.69, 4.69, 4.69);
- Sensor-Surface: 4mm (Mechanical Surface Detection)
- Electronics: DAE3 Sn432; Calibrated: 20/08/2014
- Phantom: ELI v5.0; Type: QDOVA002AA;
- Measurement SW: DASY4, V4.7 Build 80; Postprocessing SW: SEMCAD, V1.8 Build 186

Back of EUT Facing Phantom - Middle/Area Scan (61x121x1): Measurement grid: dx=15mm, dy=15mm

Maximum value of SAR (interpolated) = 0.490 mW/g

Back of EUT Facing Phantom - Middle/Zoom Scan (5x5x7) (5x5x7)/Cube 0: Measurement grid: dx=8mm, dy=8mm, dz=5mm

Reference Value = 17.3 V/m; Power Drift = 0.078 dB

Peak SAR (extrapolated) = 0.947 W/kg

SAR(1 g) = 0.412 mW/g; SAR(10 g) = 0.177 mW/g

Maximum value of SAR (measured) = 0.489 mW/g

015: Top of EUT Facing Phantom EDGE 1900 CH661 Reduced Power

Date: 25/06/2015

DUT: Inari; Type: Tablet

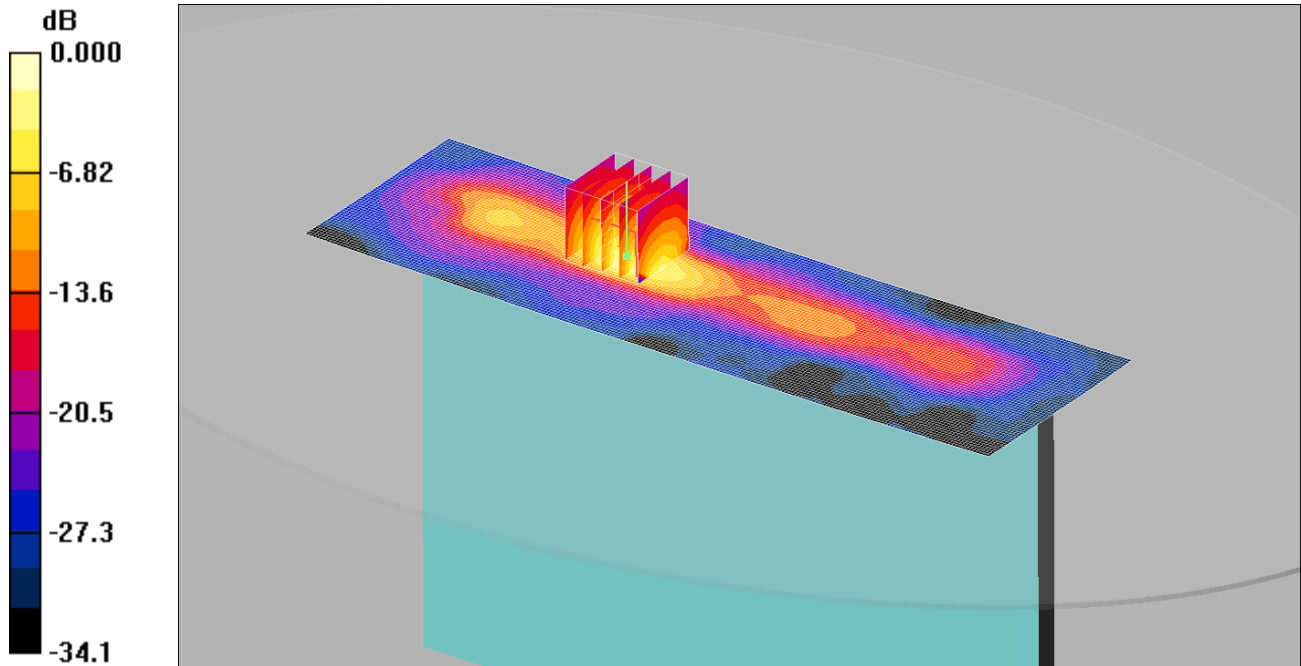

0 dB = 0.613mW/g

Communication System: EGPRS 1900 2Tx; Frequency: 1880 MHz; Duty Cycle: 1:4

Medium: 1900 MHz MSL Medium parameters used (interpolated): $f = 1880$ MHz; $\sigma = 1.47$ mho/m; $\epsilon_r = 52.5$; $\rho = 1000$ kg/m³

Phantom section: Flat Section

DASY4 Configuration:

- Probe: ES3DV3 - SN3304; ConvF(4.69, 4.69, 4.69);
- Sensor-Surface: 4mm (Mechanical Surface Detection)
- Electronics: DAE3 Sn432; Calibrated: 20/08/2014
- Phantom: ELI v5.0; Type: QDOVA002AA;
- Measurement SW: DASY4, V4.7 Build 80; Postprocessing SW: SEMCAD, V1.8 Build 186

Top of EUT Facing Phantom - Middle/Area Scan (61x201x1): Measurement grid: dx=15mm, dy=15mm

Maximum value of SAR (interpolated) = 0.569 mW/g

Top of EUT Facing Phantom - Middle/Zoom Scan (5x5x7) (5x5x7)/Cube 0: Measurement grid: dx=8mm, dy=8mm, dz=5mm

Reference Value = 5.26 V/m; Power Drift = -0.011 dB

Peak SAR (extrapolated) = 1.22 W/kg

SAR(1 g) = 0.526 mW/g; SAR(10 g) = 0.220 mW/g

Maximum value of SAR (measured) = 0.613 mW/g

016: Top of EUT Facing Phantom GPRS 1900 CH512 Reduced Power

Date: 25/06/2015

DUT: Inari; Type: Tablet

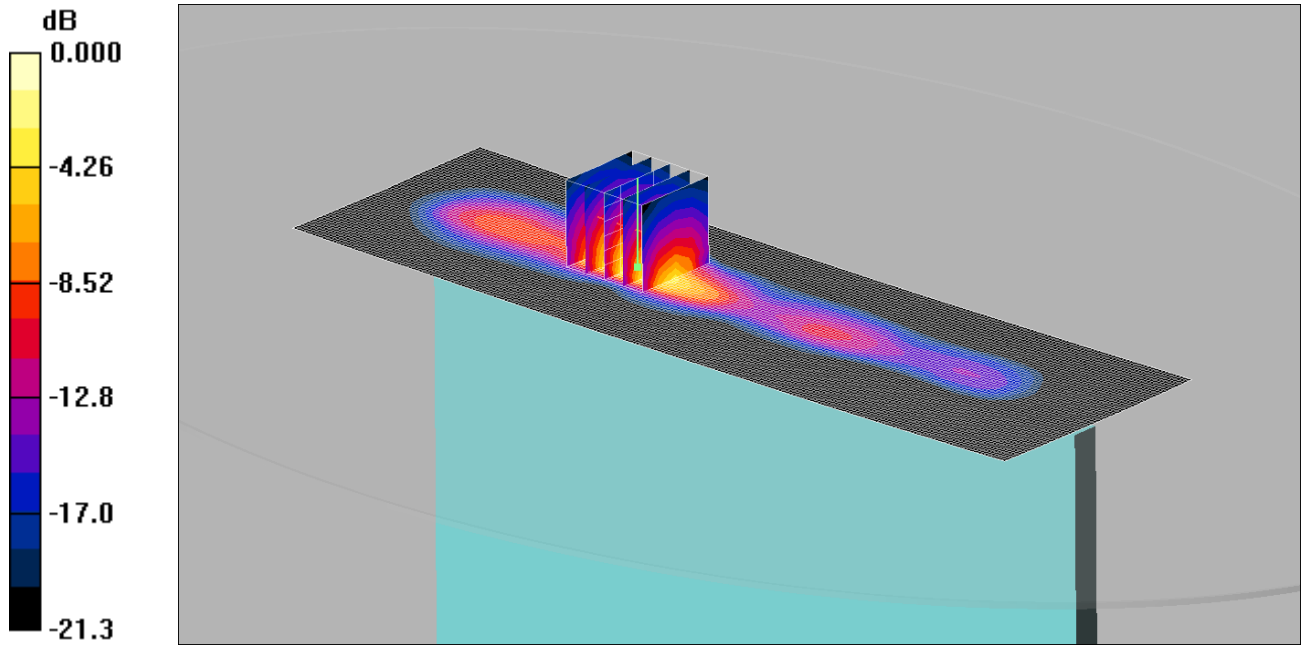

0 dB = 0.612mW/g

Communication System: GPRS 1900 2Tx; Frequency: 1850.2 MHz; Duty Cycle: 1:4

Medium: 1900 MHz MSL Medium parameters used (interpolated): $f = 1850.2$ MHz; $\sigma = 1.44$ mho/m; $\epsilon_r = 52.7$; $\rho = 1000$ kg/m³

Phantom section: Flat Section

DASY4 Configuration:

- Probe: ES3DV3 - SN3304; ConvF(4.69, 4.69, 4.69);
- Sensor-Surface: 4mm (Mechanical Surface Detection)
- Electronics: DAE3 Sn432; Calibrated: 20/08/2014
- Phantom: ELI v5.0; Type: QDOVA002AA;
- Measurement SW: DASY4, V4.7 Build 80; Postprocessing SW: SEMCAD, V1.8 Build 186

Top of EUT Facing Phantom - Middle/Area Scan (61x201x1): Measurement grid: dx=15mm, dy=15mm

Maximum value of SAR (interpolated) = 0.641 mW/g

Top of EUT Facing Phantom - Middle/Zoom Scan (5x5x7) (5x5x7)/Cube 0: Measurement grid: dx=8mm, dy=8mm, dz=5mm

Reference Value = 5.24 V/m; Power Drift = -0.223 dB

Peak SAR (extrapolated) = 1.22 W/kg

SAR(1 g) = 0.525 mW/g; SAR(10 g) = 0.218 mW/g

Maximum value of SAR (measured) = 0.612 mW/g

017: Top of EUT Facing Phantom GPRS 1900 CH810 Reduced Power

Date: 25/06/2015

DUT: Inari; Type: Tablet

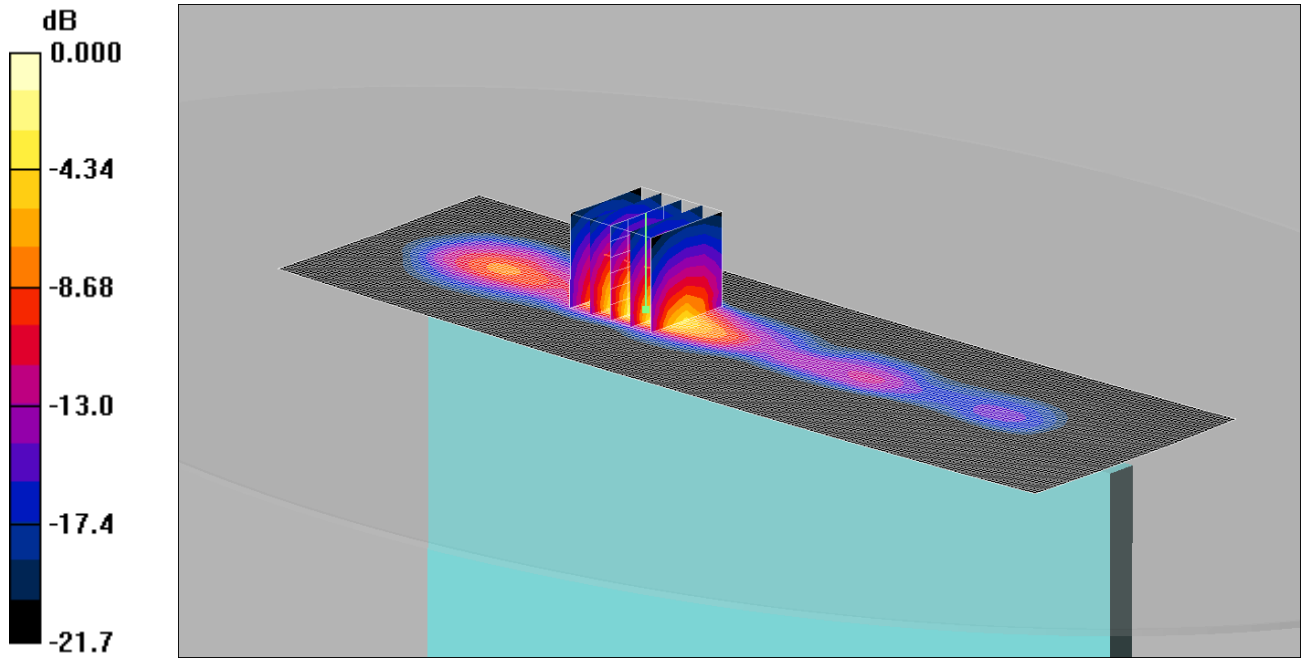

0 dB = 0.613mW/g

Communication System: GPRS 1900 2Tx; Frequency: 1909.8 MHz; Duty Cycle: 1:4

Medium: 1900 MHz MSL Medium parameters used (interpolated): $f = 1909.8$ MHz; $\sigma = 1.5$ mho/m; $\epsilon_r = 52.4$; $\rho = 1000$ kg/m³

Phantom section: Flat Section

DASY4 Configuration:

- Probe: ES3DV3 - SN3304; ConvF(4.69, 4.69, 4.69);
- Sensor-Surface: 4mm (Mechanical Surface Detection)
- Electronics: DAE3 Sn432; Calibrated: 20/08/2014
- Phantom: ELI v5.0; Type: QDOVA002AA;
- Measurement SW: DASY4, V4.7 Build 80; Postprocessing SW: SEMCAD, V1.8 Build 186

Top of EUT Facing Phantom - Middle/Area Scan (61x201x1): Measurement grid: dx=15mm, dy=15mm

Maximum value of SAR (interpolated) = 0.657 mW/g

Top of EUT Facing Phantom - Middle/Zoom Scan (5x5x7) (5x5x7)/Cube 0: Measurement grid: dx=8mm, dy=8mm, dz=5mm

Reference Value = 4.59 V/m; Power Drift = -0.167 dB

Peak SAR (extrapolated) = 1.22 W/kg

SAR(1 g) = 0.524 mW/g; SAR(10 g) = 0.216 mW/g

Maximum value of SAR (measured) = 0.613 mW/g

018: Back Of EUT Facing Phantom WCDMA 2 CH9400

Date: 02/06/2015

DUT: Inari; Type: Tablet

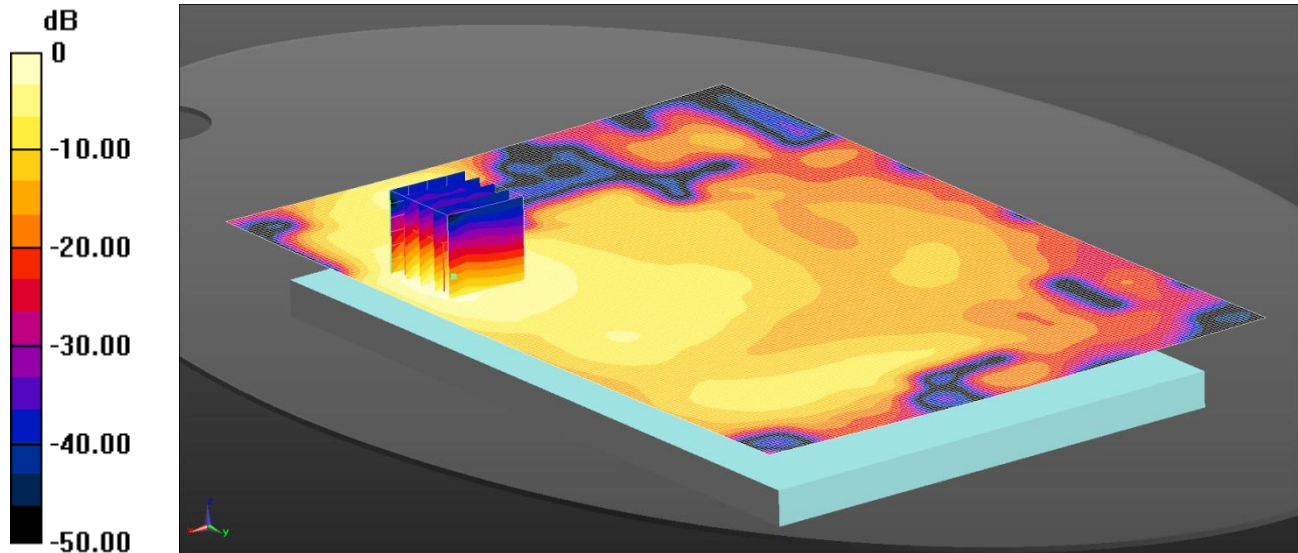

0 dB = 0.722 W/kg = -1.41 dBW/kg

Communication System: UID 0, WCDMA FDD (0); Frequency: 1880 MHz; Duty Cycle: 1:1

Medium: 1900MHz MSL Medium parameters used (interpolated): $f = 1880$ MHz; $\sigma = 1.454$ S/m; $\epsilon_r = 52.615$; $\rho = 1000$ kg/m³

Phantom section: Flat Section

DASY4 Configuration:

- Probe: EX3DV4 - SN3994; ConvF(7.63, 7.63, 7.63); Calibrated: 17/03/2015;
- Sensor-Surface: 4mm (Mechanical Surface Detection)
- Electronics: DAE3 Sn450; Calibrated: 16/09/2014
- Phantom: ELI v5.0; Type: QDOVA002AA;
- ; SEMCAD X Version 14.6.10 (7164)

Configuration/Back of EUT Facing Phantom 2 2 2/Area Scan (141x201x1): Interpolated grid: dx=1.500 mm, dy=1.500 mm

Maximum value of SAR (interpolated) = 0.722 W/kg

Configuration/Back of EUT Facing Phantom 2 2 2/Zoom Scan (7x7x7) (5x5x7)/Cube 0: Measurement grid: dx=8mm, dy=8mm, dz=5mm

Reference Value = 11.972 V/m; Power Drift = -0.00 dB

Peak SAR (extrapolated) = 1.14 W/kg

SAR(1 g) = 0.674 W/kg; SAR(10 g) = 0.378 W/kg

Maximum value of SAR (measured) = 0.706 W/kg

019: Back Of EUT Facing Phantom WCDMA 2 CH9262

Date: 02/06/2015

DUT: Inari; Type: Tablet

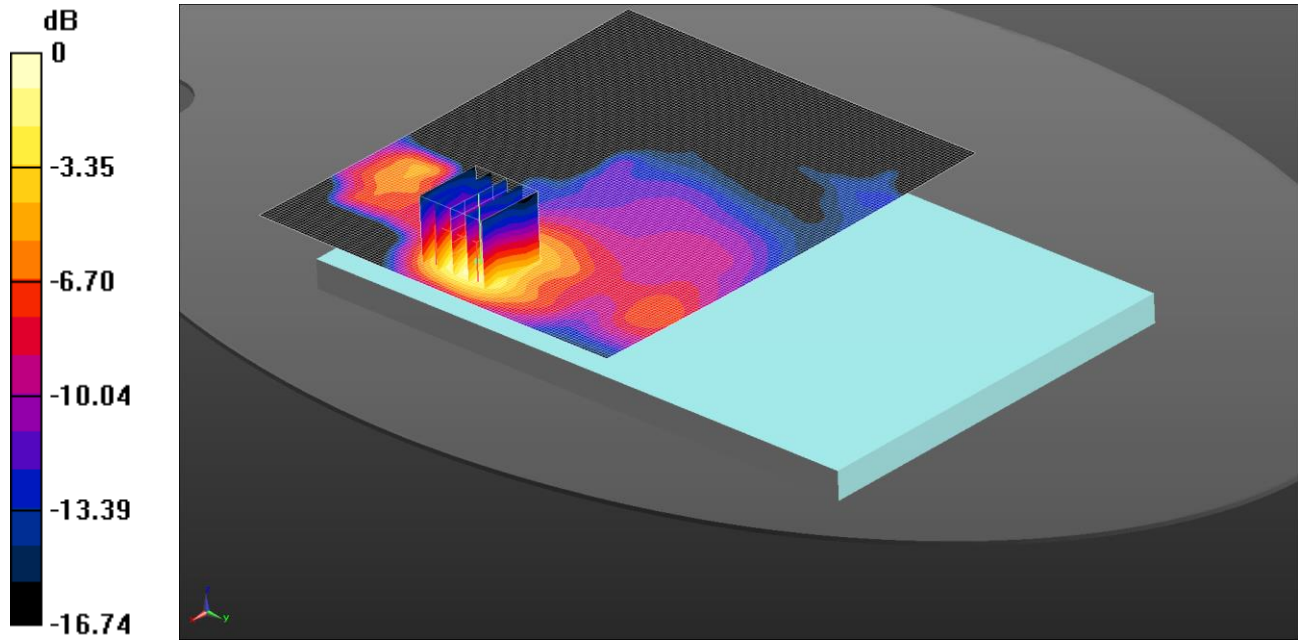

0 dB = 0.796 W/kg = -0.99 dBW/kg

Communication System: UID 0, WCDMA FDD (0); Frequency: 1852.4 MHz; Duty Cycle: 1:1

Medium: 1900MHz MSL Medium parameters used (interpolated): $f = 1852.4$ MHz; $\sigma = 1.424$ S/m; $\epsilon_r = 52.683$; $\rho = 1000$ kg/m³

Phantom section: Flat Section

DASY4 Configuration:

- Probe: EX3DV4 - SN3994; ConvF(7.63, 7.63, 7.63); Calibrated: 17/03/2015;
- Sensor-Surface: 4mm (Mechanical Surface Detection)
- Electronics: DAE3 Sn450; Calibrated: 16/09/2014
- Phantom: ELI v5.0; Type: QDOVA002AA;
- ; SEMCAD X Version 14.6.10 (7164)

Configuration/Back of EUT Facing Phantom 2 2 2/Area Scan (141x121x1): Interpolated grid: dx=1.500 mm, dy=1.500 mm

Maximum value of SAR (interpolated) = 0.790 W/kg

Configuration/Back of EUT Facing Phantom 2 2 2/Zoom Scan (7x7x7) (5x5x7)/Cube 0: Measurement grid: dx=8mm, dy=8mm, dz=5mm

Reference Value = 14.059 V/m; Power Drift = 0.05 dB

Peak SAR (extrapolated) = 1.24 W/kg

SAR(1 g) = 0.727 W/kg; SAR(10 g) = 0.399 W/kg

Maximum value of SAR (measured) = 0.796 W/kg

020: Back Of EUT Facing Phantom WCDMA 2 CH9538

Date: 03/06/2015

DUT: Inari; Type: Tablet

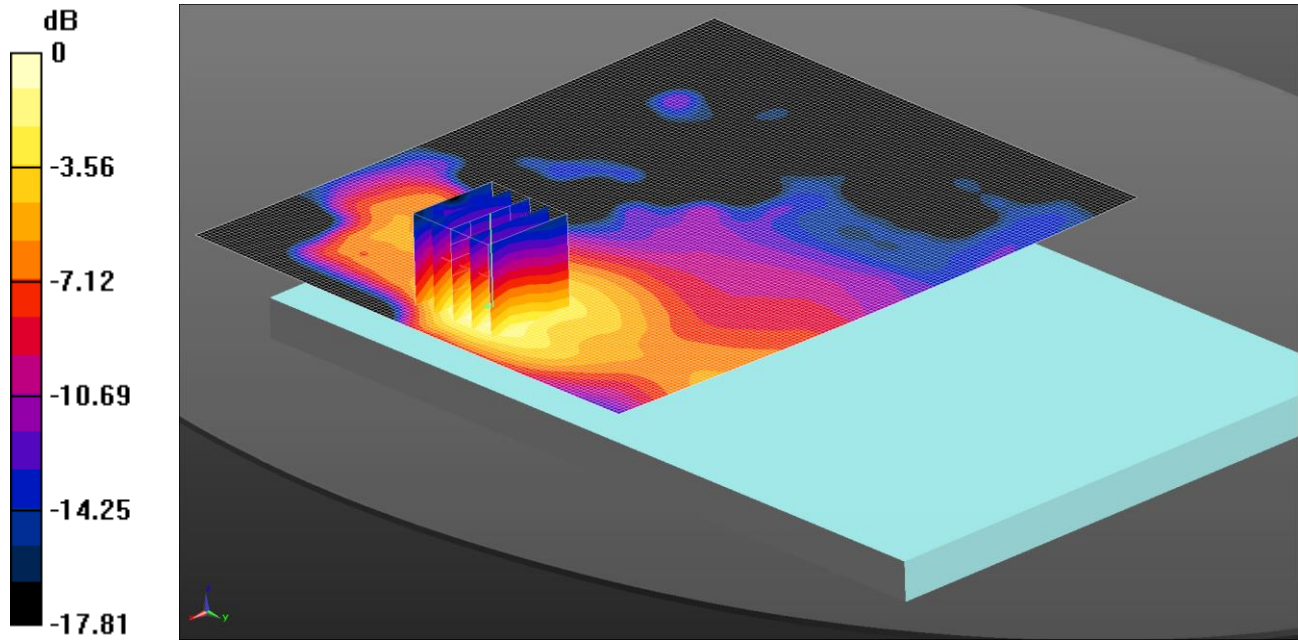

0 dB = 0.701 W/kg = -1.54 dBW/kg

Communication System: UID 0, WCDMA FDD (0); Frequency: 1907.6 MHz; Duty Cycle: 1:1

Medium: 1900MHz MSL Medium parameters used (interpolated): $f = 1907.6$ MHz; $\sigma = 1.483$ S/m; $\epsilon_r = 52.542$; $\rho = 1000$ kg/m³

Phantom section: Flat Section

DASY4 Configuration:

- Probe: EX3DV4 - SN3994; ConvF(7.63, 7.63, 7.63); Calibrated: 17/03/2015;
- Sensor-Surface: 4mm (Mechanical Surface Detection)
- Electronics: DAE3 Sn450; Calibrated: 16/09/2014
- Phantom: ELI v5.0; Type: QDOVA002AA;
- ; SEMCAD X Version 14.6.10 (7164)

Configuration/Back of EUT Facing Phantom 2 2 2/Area Scan (141x121x1): Interpolated grid: dx=1.500 mm, dy=1.500 mm

Maximum value of SAR (interpolated) = 0.672 W/kg

Configuration/Back of EUT Facing Phantom 2 2 2/Zoom Scan (7x7x7) (5x5x7)/Cube 0: Measurement grid: dx=8mm, dy=8mm, dz=5mm

Reference Value = 6.887 V/m; Power Drift = 0.11 dB

Peak SAR (extrapolated) = 1.11 W/kg

SAR(1 g) = 0.635 W/kg; SAR(10 g) = 0.352 W/kg

Maximum value of SAR (measured) = 0.701 W/kg

021: Top Of EUT Facing Phantom WCDMA 2 CH9400

Date: 03/06/2015

DUT: Inari; Type: Tablet

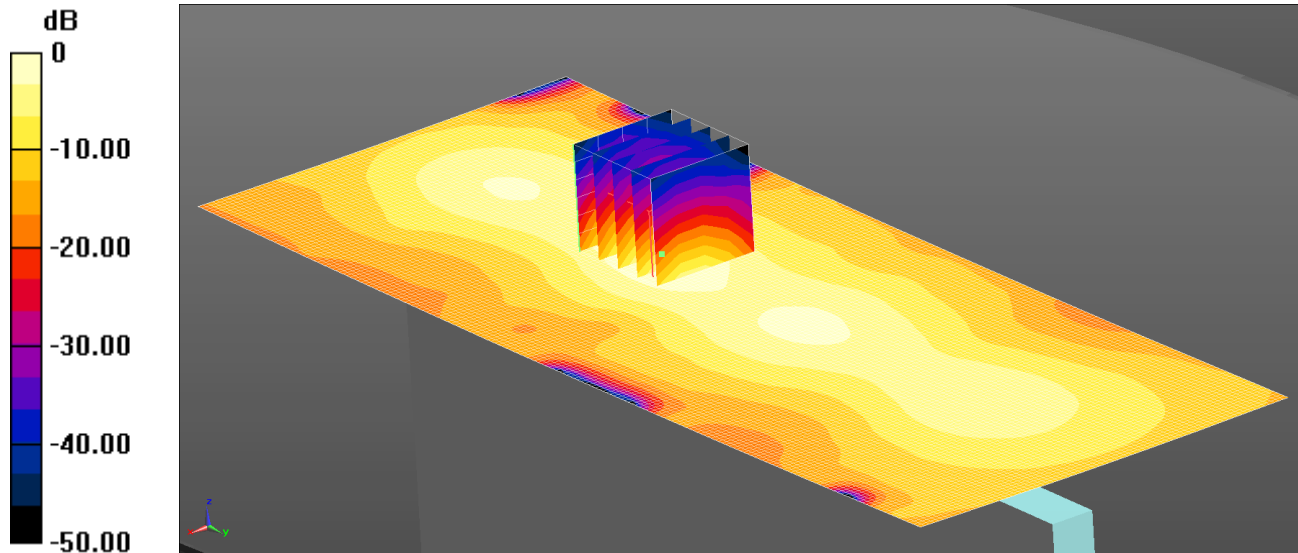

0 dB = 0.540 W/kg = -2.67 dBW/kg

Communication System: UID 0, WCDMA FDD (0); Frequency: 1880 MHz; Duty Cycle: 1:1

Medium: 1900MHz MSL Medium parameters used (interpolated): $f = 1880$ MHz; $\sigma = 1.454$ S/m; $\epsilon_r = 52.615$; $\rho = 1000$ kg/m³

Phantom section: Flat Section

DASY4 Configuration:

- Probe: EX3DV4 - SN3994; ConvF(7.63, 7.63, 7.63); Calibrated: 17/03/2015;
- Sensor-Surface: 4mm (Mechanical Surface Detection)
- Electronics: DAE3 Sn450; Calibrated: 16/09/2014
- Phantom: ELI v5.0; Type: QDOVA002AA;
- ; SEMCAD X Version 14.6.10 (7164)

Configuration/Back of EUT Facing Phantom 2 2 2/Area Scan (81x201x1): Interpolated grid: dx=1.500 mm, dy=1.500 mm

Maximum value of SAR (interpolated) = 0.540 W/kg

Configuration/Back of EUT Facing Phantom 2 2 2/Zoom Scan (7x7x7) (5x5x7)/Cube 0: Measurement grid: dx=8mm, dy=8mm, dz=5mm

Reference Value = 9.354 V/m; Power Drift = -0.02 dB

Peak SAR (extrapolated) = 0.828 W/kg

SAR(1 g) = 0.494 W/kg; SAR(10 g) = 0.277 W/kg

Maximum value of SAR (measured) = 0.542 W/kg

022: Back Of EUT Facing Phantom WCDMA 2 CH9262 Reduced Power

Date: 22/06/15

DUT: Inari; Type: Tablet

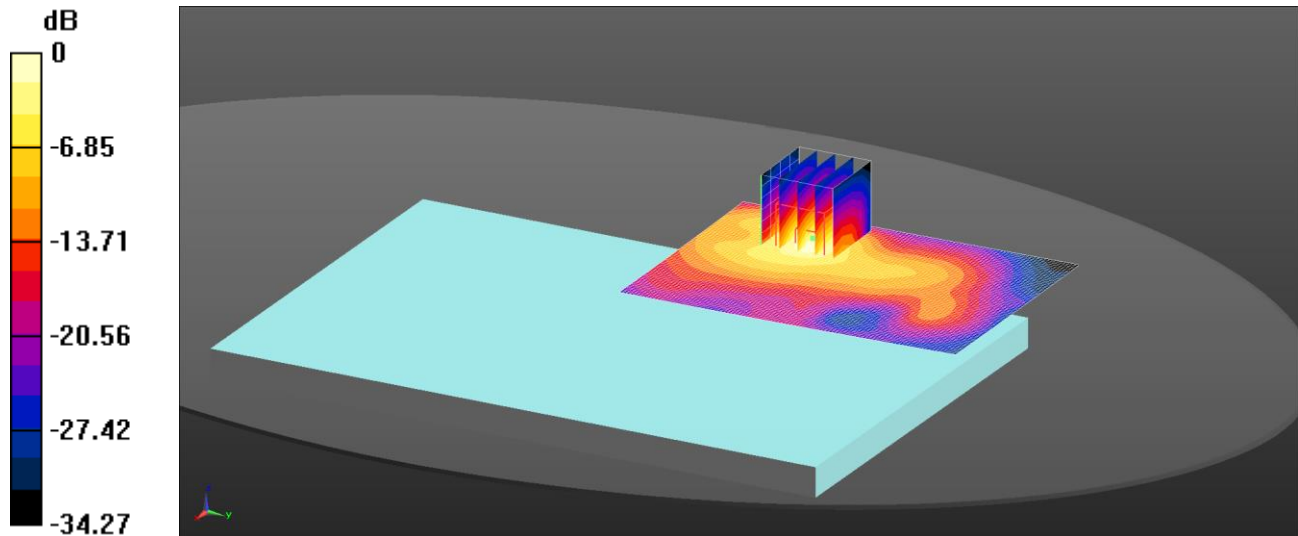

0 dB = 0.603 W/kg = -2.19 dBW/kg

Communication System: UID 0, WCDMA FDD (0); Frequency: 1852.4 MHz; Duty Cycle: 1:1

Medium: 1900MHz MSL Medium parameters used (interpolated): $f = 1852.4$ MHz; $\sigma = 1.415$ S/m; $\epsilon_r = 51.767$; $\rho = 1000$ kg/m³

Phantom section: Flat Section

DASY4 Configuration:

- Probe: ES3DV3 - SN3335; ConvF(4.69, 4.69, 4.69); Calibrated: 29/08/14;
- Sensor-Surface: 4mm (Mechanical Surface Detection)
- Electronics: DAE3 Sn450; Calibrated: 16/09/14
- Phantom: ELI v5.0; Type: QDOVA002AA;
- ; SEMCAD X Version 14.6.10 (7331)

Configuration/Back of EUT Facing Phantom 2 2 /Area Scan (71x101x1): Interpolated grid: dx=1.500 mm, dy=1.500 mm

Maximum value of SAR (interpolated) = 0.603 W/kg

Configuration/Back of EUT Facing Phantom 2 2 /Zoom Scan (7x7x7) (5x5x7)/Cube 0: Measurement grid: dx=8mm, dy=8mm, dz=5mm

Reference Value = 21.71 V/m; Power Drift = -0.04 dB

Peak SAR (extrapolated) = 1.31 W/kg

SAR(1 g) = 0.588 W/kg; SAR(10 g) = 0.257 W/kg

Maximum value of SAR (measured) = 0.642 W/kg

023: Top Of EUT Facing Phantom WCDMA 2 CH9262 Reduced Power

Date: 23/06/15

DUT: Inari; Type: Tablet

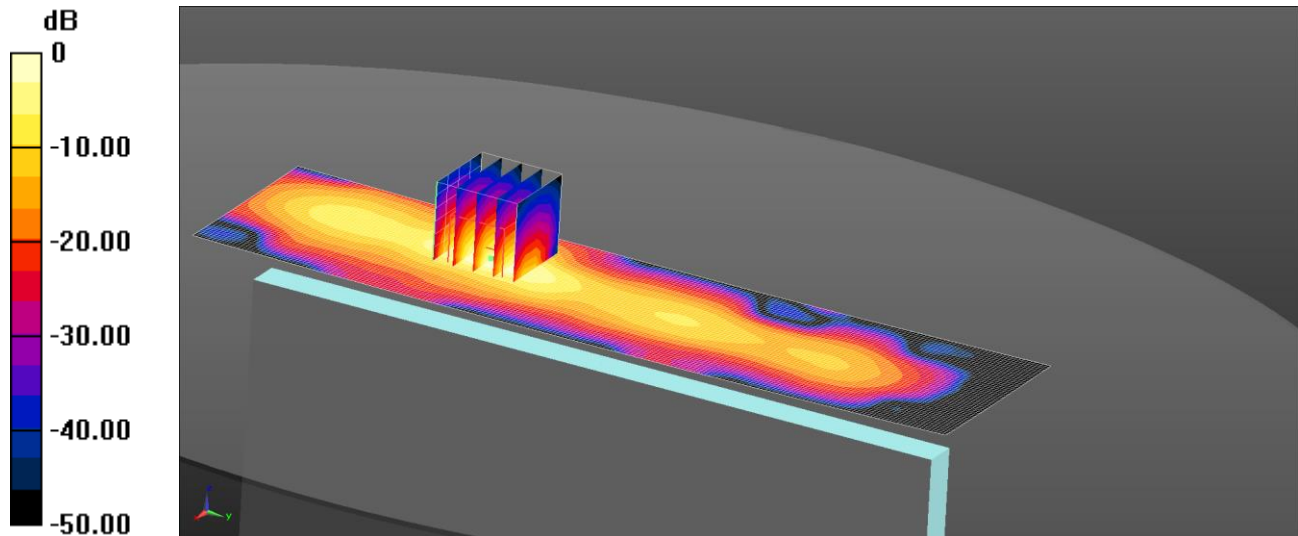

0 dB = 0.533 W/kg = -2.73 dBW/kg

Communication System: UID 0, WCDMA FDD (0); Frequency: 1852.4 MHz; Duty Cycle: 1:1

Medium: 1900MHz MSL Medium parameters used (interpolated): $f = 1852.4$ MHz; $\sigma = 1.415$ S/m; $\epsilon_r = 51.767$; $\rho = 1000$ kg/m³

Phantom section: Flat Section

DASY4 Configuration:

- Probe: ES3DV3 - SN3335; ConvF(4.69, 4.69, 4.69); Calibrated: 29/08/14;
- Sensor-Surface: 4mm (Mechanical Surface Detection)
- Electronics: DAE3 Sn450; Calibrated: 16/09/14
- Phantom: ELI v5.0; Type: QDOVA002AA;
- ; SEMCAD X Version 14.6.10 (7331)

Configuration/Top of EUT Facing Phantom 2 2 2 2/Area Scan (51x201x1): Interpolated grid: dx=1.500 mm, dy=1.500 mm

Maximum value of SAR (interpolated) = 0.533 W/kg

Configuration/Top of EUT Facing Phantom 2 2 2 2/Zoom Scan (7x7x7) (5x5x7)/Cube 0: Measurement grid: dx=8mm, dy=8mm, dz=5mm

Reference Value = 19.70 V/m; Power Drift = -0.09 dB

Peak SAR (extrapolated) = 1.01 W/kg

SAR(1 g) = 0.452 W/kg; SAR(10 g) = 0.195 W/kg

Maximum value of SAR (measured) = 0.494 W/kg

024: Back Of EUT Facing Phantom WCDMA 2 CH9400 Reduced Power

Date: 22/06/15

DUT: Inari; Type: Tablet

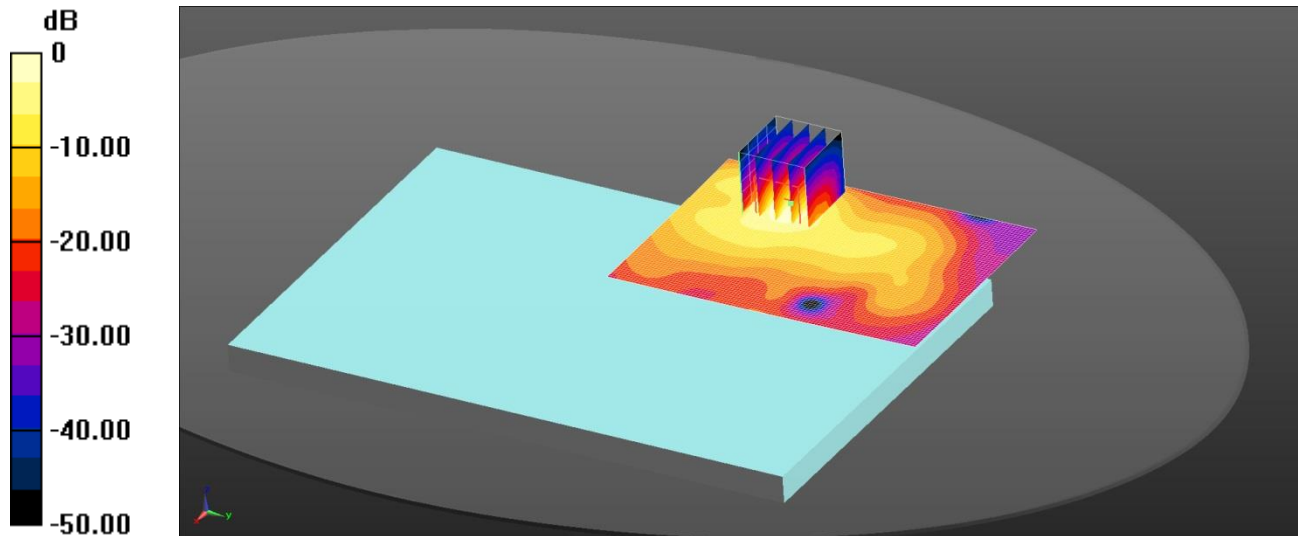

0 dB = 0.756 W/kg = -1.21 dBW/kg

Communication System: UID 0, WCDMA FDD (0); Frequency: 1880 MHz; Duty Cycle: 1:1

Medium: 1900MHz MSL Medium parameters used (interpolated): $f = 1880$ MHz; $\sigma = 1.441$ S/m; $\epsilon_r = 51.662$; $\rho = 1000$ kg/m³

Phantom section: Flat Section

DASY4 Configuration:

- Probe: ES3DV3 - SN3335; ConvF(4.69, 4.69, 4.69); Calibrated: 29/08/14;
- Sensor-Surface: 4mm (Mechanical Surface Detection)
- Electronics: DAE3 Sn450; Calibrated: 16/09/14
- Phantom: ELI v5.0; Type: QDOVA002AA;
- ; SEMCAD X Version 14.6.10 (7331)

Configuration/Back of EUT Facing Phantom 2 2 2/Area Scan (71x101x1): Interpolated grid: dx=1.500 mm, dy=1.500 mm

Maximum value of SAR (interpolated) = 0.756 W/kg

Configuration/Back of EUT Facing Phantom 2 2 2/Zoom Scan (7x7x7) (5x5x7)/Cube 0: Measurement grid: dx=8mm, dy=8mm, dz=5mm

Reference Value = 20.67 V/m; Power Drift = -0.03 dB

Peak SAR (extrapolated) = 1.65 W/kg

SAR(1 g) = 0.734 W/kg; SAR(10 g) = 0.318 W/kg

Maximum value of SAR (measured) = 0.803 W/kg

025: Back Of EUT Facing Phantom WCDMA 2 CH9538 Reduced Power

Date: 22/06/15

DUT: Inari; Type: Tablet

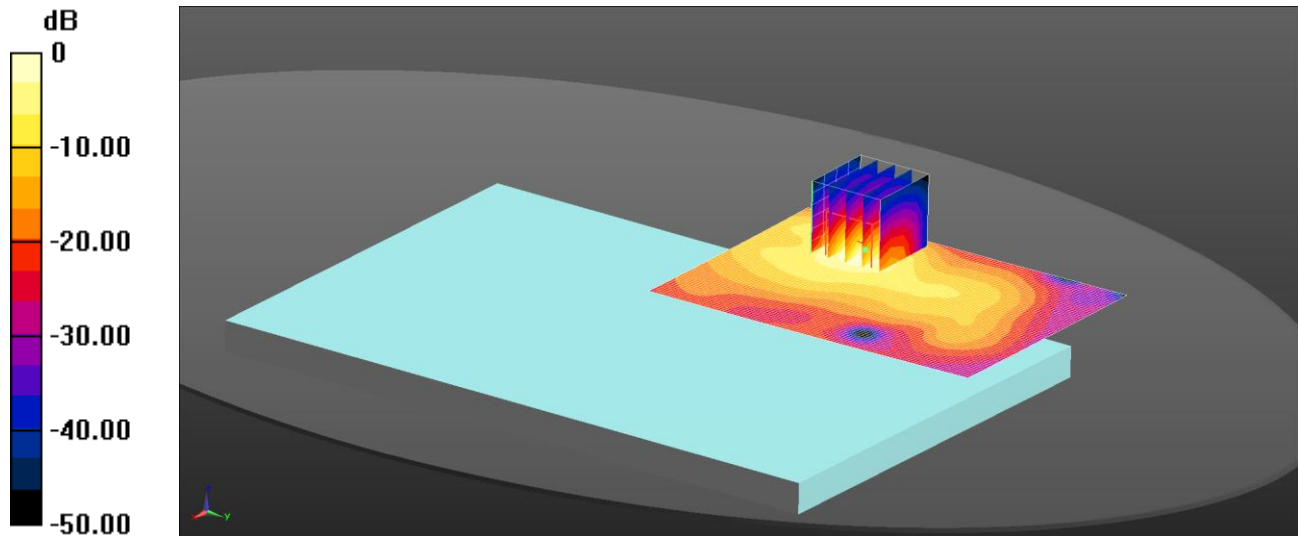

0 dB = 0.647 W/kg = -1.89 dBW/kg

Communication System: UID 0, WCDMA FDD (0); Frequency: 1907.6 MHz; Duty Cycle: 1:1

Medium: 1900MHz MSL Medium parameters used (interpolated): $f = 1907.6$ MHz; $\sigma = 1.466$ S/m; $\epsilon_r = 51.56$; $\rho = 1000$ kg/m³

Phantom section: Flat Section

DASY4 Configuration:

- Probe: ES3DV3 - SN3335; ConvF(4.69, 4.69, 4.69); Calibrated: 29/08/14;
- Sensor-Surface: 4mm (Mechanical Surface Detection)
- Electronics: DAE3 Sn450; Calibrated: 16/09/14
- Phantom: ELI v5.0; Type: QDOVA002AA;
- ; SEMCAD X Version 14.6.10 (7331)

Configuration/Back of EUT Facing Phantom 2 2 2/Area Scan (71x101x1): Interpolated grid: dx=1.500 mm, dy=1.500 mm

Maximum value of SAR (interpolated) = 0.647 W/kg

Configuration/Back of EUT Facing Phantom 2 2 2/Zoom Scan (7x7x7) (5x5x7)/Cube 0: Measurement grid: dx=8mm, dy=8mm, dz=5mm

Reference Value = 22.02 V/m; Power Drift = -0.04 dB

Peak SAR (extrapolated) = 1.41 W/kg

SAR(1 g) = 0.623 W/kg; SAR(10 g) = 0.268 W/kg

Maximum value of SAR (measured) = 0.680 W/kg

026: Back of EUT Facing Phantom WCDMA FDD 4 CH1412

Date: 22/06/2015

DUT: Inari; Type: Tablet

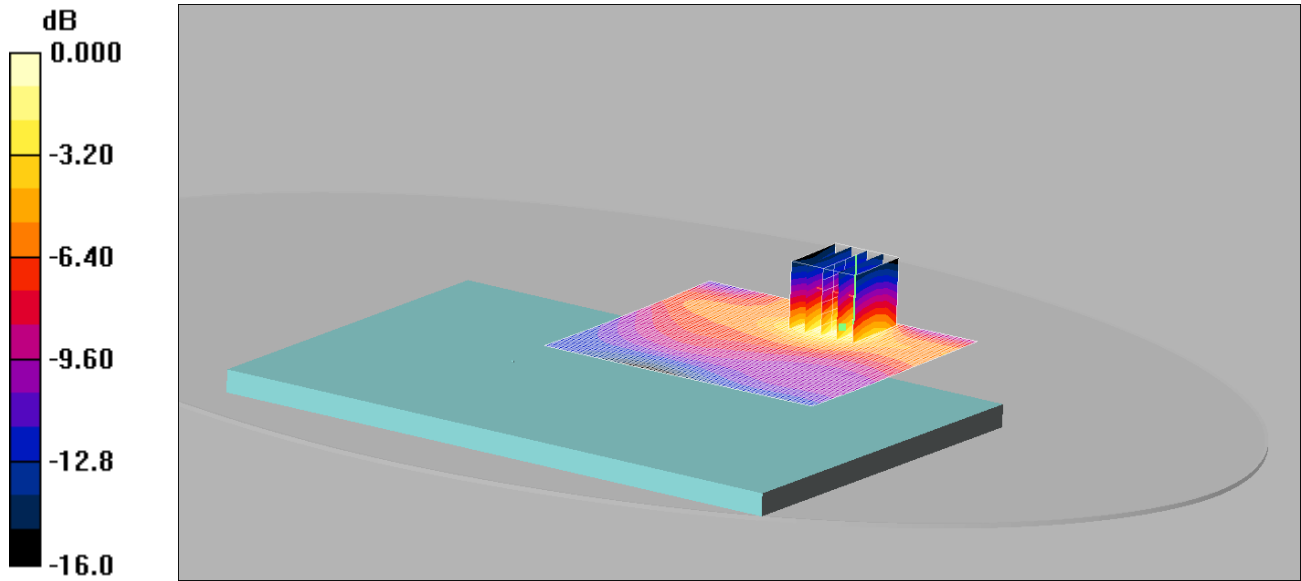

0 dB = 0.836mW/g

Communication System: WCDMA-FDD IV; Frequency: 1732.4 MHz; Duty Cycle: 1:1

Medium: 1800 MHz MSL Medium parameters used (interpolated): $f = 1732.4$ MHz; $\sigma = 1.51$ mho/m; $\epsilon_r = 52.6$; $\rho = 1000$ kg/m³

Phantom section: Flat Section

DASY4 Configuration:

- Probe: ES3DV3 - SN3304; ConvF(4.86, 4.86, 4.86);

- Sensor-Surface: 4mm

(Mechanical Surface Detection)

- Electronics: DAE3 Sn432; Calibrated: 20/08/2014

- Phantom: ELI v5.0; Type: QDOVA002AA;

- Measurement SW: DASY4, V4.7 Build 80; Postprocessing SW: SEMCAD, V1.8 Build 186

Back of EUT Facing Phantom - Middle/Area Scan (81x91x1): Measurement grid: dx=15mm, dy=15mm

Maximum value of SAR (interpolated) = 0.829 mW/g

Back of EUT Facing Phantom - Middle/Zoom Scan (5x5x7) (5x5x7)/Cube 0: Measurement grid: dx=8mm, dy=8mm, dz=5mm

Reference Value = 6.35 V/m; Power Drift = 0.064 dB

Peak SAR (extrapolated) = 1.39 W/kg

SAR(1 g) = 0.774 mW/g; SAR(10 g) = 0.423 mW/g

Maximum value of SAR (measured) = 0.836 mW/g

027: Top of EUT Facing Phantom WCDMA FDD 4 CH1412

Date: 22/06/2015

DUT: Inari; Type: Tablet

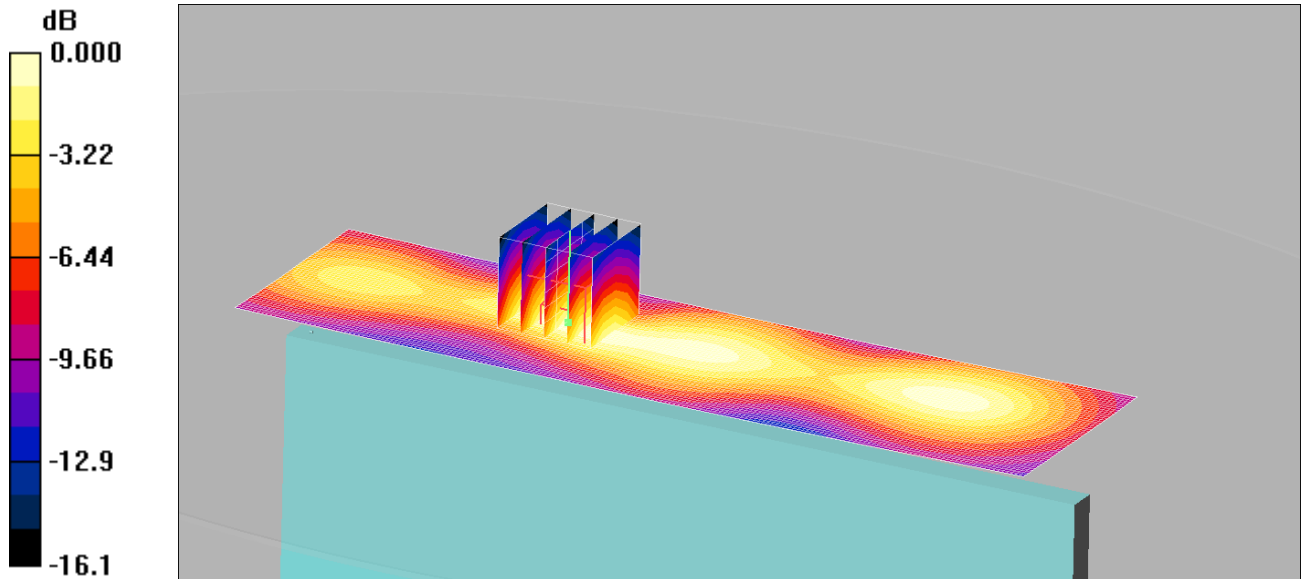

0 dB = 0.327mW/g

Communication System: WCDMA-FDD IV; Frequency: 1732.4 MHz; Duty Cycle: 1:1

Medium: 1800 MHz MSL Medium parameters used (interpolated): $f = 1732.4$ MHz; $\sigma = 1.51$ mho/m; $\epsilon_r = 52.6$; $\rho = 1000$ kg/m³

Phantom section: Flat Section

DASY4 Configuration:

- Probe: ES3DV3 - SN3304; ConvF(4.86, 4.86, 4.86);

- Sensor-Surface: 4mm

(Mechanical Surface Detection)

- Electronics: DAE3 Sn432; Calibrated: 20/08/2014

- Phantom: ELI v5.0; Type: QDOVA002AA;

- Measurement SW: DASY4, V4.7 Build 80; Postprocessing SW: SEMCAD, V1.8 Build 186

Top of EUT Facing Phantom - Middle/Area Scan (51x181x1): Measurement grid: dx=15mm, dy=15mm

Maximum value of SAR (interpolated) = 0.331 mW/g

Top of EUT Facing Phantom - Middle/Zoom Scan (5x5x7) (5x5x7)/Cube 0: Measurement grid: dx=8mm, dy=8mm, dz=5mm

Reference Value = 13.5 V/m; Power Drift = -0.004 dB

Peak SAR (extrapolated) = 0.503 W/kg

SAR(1 g) = 0.294 mW/g; SAR(10 g) = 0.165 mW/g

Maximum value of SAR (measured) = 0.327 mW/g

028: Back of EUT Facing Phantom WCDMA FDD 4 CH1312

Date: 22/06/2015

DUT: Inari; Type: Tablet

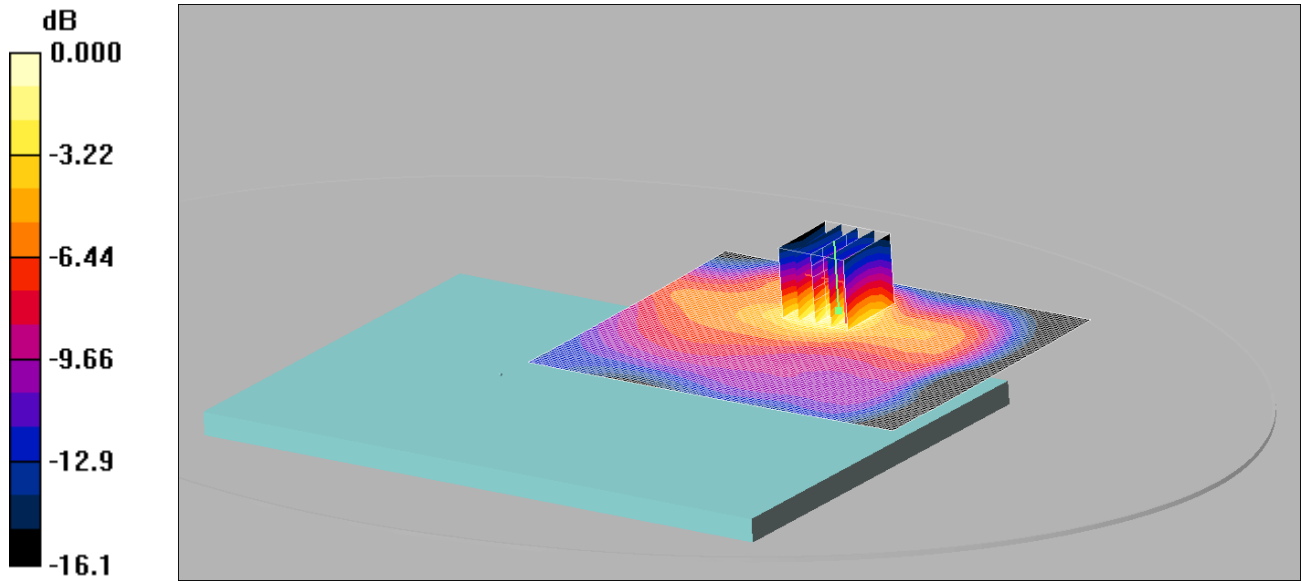

0 dB = 0.825mW/g

Communication System: WCDMA-FDD IV; Frequency: 1712.4 MHz; Duty Cycle: 1:1

Medium: 1800 MHz MSL Medium parameters used (interpolated): $f = 1712.4$ MHz; $\sigma = 1.49$ mho/m; $\epsilon_r = 52.6$; $\rho = 1000$ kg/m³

Phantom section: Flat Section

DASY4 Configuration:

- Probe: ES3DV3 - SN3304; ConvF(4.86, 4.86, 4.86);
- Sensor-Surface: 4mm (Mechanical Surface Detection)
- Electronics: DAE3 Sn432; Calibrated: 20/08/2014
- Phantom: ELI v5.0; Type: QDOVA002AA;
- Measurement SW: DASY4, V4.7 Build 80; Postprocessing SW: SEMCAD, V1.8 Build 186

Back of EUT Facing Phantom - Low/Area Scan (91x121x1): Measurement grid: dx=15mm, dy=15mm

Maximum value of SAR (interpolated) = 0.822 mW/g

Back of EUT Facing Phantom - Low/Zoom Scan (5x5x7) (5x5x7)/Cube 0: Measurement grid: dx=8mm, dy=8mm, dz=5mm

Reference Value = 6.50 V/m; Power Drift = -0.042 dB

Peak SAR (extrapolated) = 1.36 W/kg

SAR(1 g) = 0.754 mW/g; SAR(10 g) = 0.412 mW/g

Maximum value of SAR (measured) = 0.825 mW/g

029: Back of EUT Facing Phantom WCDMA FDD 4 CH1513

Date: 22/06/2015

DUT: Inari; Type: Tablet

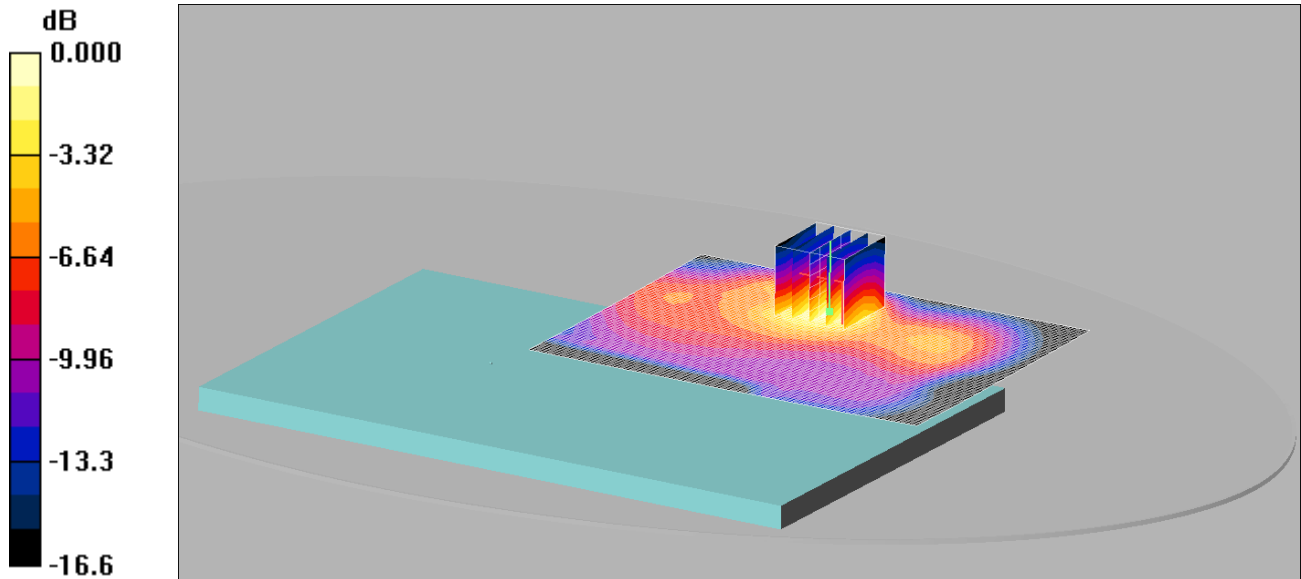

0 dB = 0.915mW/g

Communication System: WCDMA-FDD IV; Frequency: 1752.6 MHz; Duty Cycle: 1:1

Medium: 1800 MHz MSL Medium parameters used (interpolated): $f = 1752.6$ MHz; $\sigma = 1.53$ mho/m; $\epsilon_r = 52.5$; $\rho = 1000$ kg/m³

Phantom section: Flat Section

DASY4 Configuration:

- Probe: ES3DV3 - SN3304; ConvF(4.86, 4.86, 4.86);

- Sensor-Surface: 4mm

(Mechanical Surface Detection)

- Electronics: DAE3 Sn432; Calibrated: 20/08/2014

- Phantom: ELI v5.0; Type: QDOVA002AA;

- Measurement SW: DASY4, V4.7 Build 80; Postprocessing SW: SEMCAD, V1.8 Build 186

Back of EUT Facing Phantom - High/Area Scan (91x121x1): Measurement grid: dx=15mm, dy=15mm

Maximum value of SAR (interpolated) = 0.913 mW/g

Back of EUT Facing Phantom - High/Zoom Scan (5x5x7) (5x5x7)/Cube 0: Measurement grid: dx=8mm, dy=8mm, dz=5mm

Reference Value = 16.3 V/m; Power Drift = 0.037 dB

Peak SAR (extrapolated) = 1.58 W/kg

SAR(1 g) = 0.852 mW/g; SAR(10 g) = 0.460 mW/g

Maximum value of SAR (measured) = 0.915 mW/g

030: Back of EUT Facing Phantom WCDMA FDD 4 CH1412 Reduced Power

Date: 22/06/15

DUT: Inari; Type: Tablet

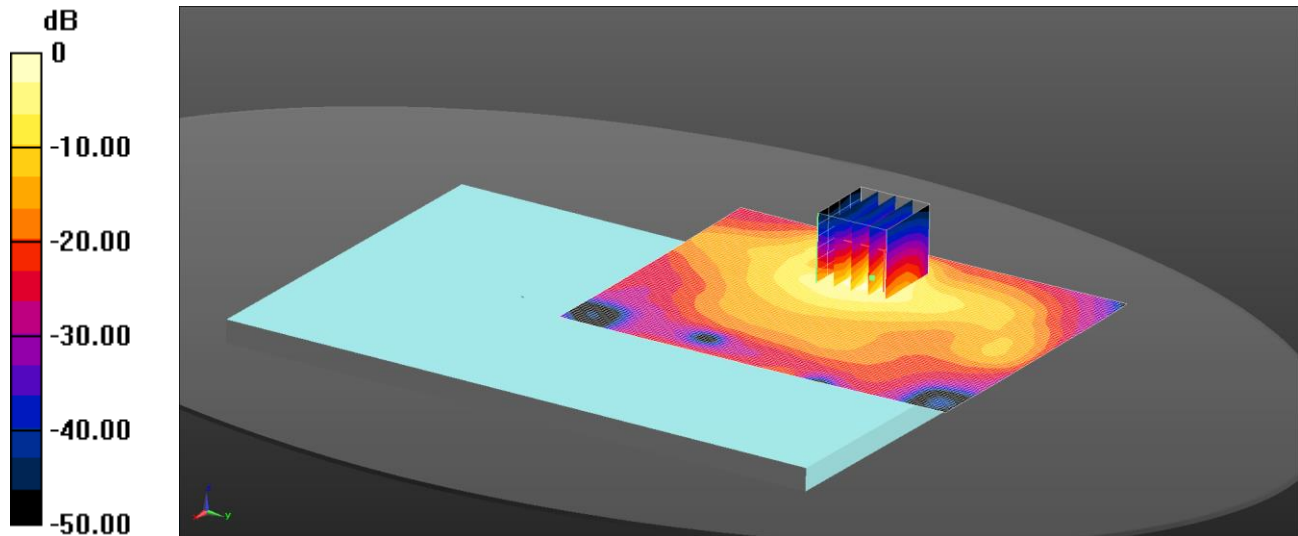

0 dB = 0.548 W/kg = -2.61 dBW/kg

Communication System: UID 0, WCDMA-FDD IV; Frequency: 1732.4 MHz; Duty Cycle: 1:1

Medium: 1800 MHz MSL Medium parameters used (interpolated): $f = 1732.4$ MHz; $\sigma = 1.508$ S/m; $\epsilon_r = 52.559$; $\rho = 1000$ kg/m³

Phantom section: Flat Section

DASY4 Configuration:

- Probe: ES3DV3 - SN3304; ConvF(4.86, 4.86, 4.86); Calibrated: 21/08/14;

- Sensor-Surface:

4mm (Mechanical Surface Detection)

- Electronics: DAE3 Sn432; Calibrated: 20/08/14

- Phantom: ELI v5.0; Type: QDOVA002AA;

- ; SEMCAD X Version 14.6.10 (7331)

Configuration/Back of EUT Facing Phantom - Middle/Area Scan (91x121x1): Interpolated grid: dx=1.500 mm, dy=1.500 mm

Maximum value of SAR (interpolated) = 0.548 W/kg

Configuration/Back of EUT Facing Phantom - Middle/Zoom Scan (5x5x7) (5x5x7)/Cube 0: Measurement grid: dx=8mm, dy=8mm, dz=5mm

Reference Value = 10.66 V/m; Power Drift = 0.07 dB

Peak SAR (extrapolated) = 1.18 W/kg

SAR(1 g) = 0.505 W/kg; SAR(10 g) = 0.221 W/kg

Maximum value of SAR (measured) = 0.568 W/kg

031: Top of EUT Facing Phantom WCDMA FDD 4 CH1412 Reduced Power

Date: 22/06/2015

DUT: Inari; Type: Tablet

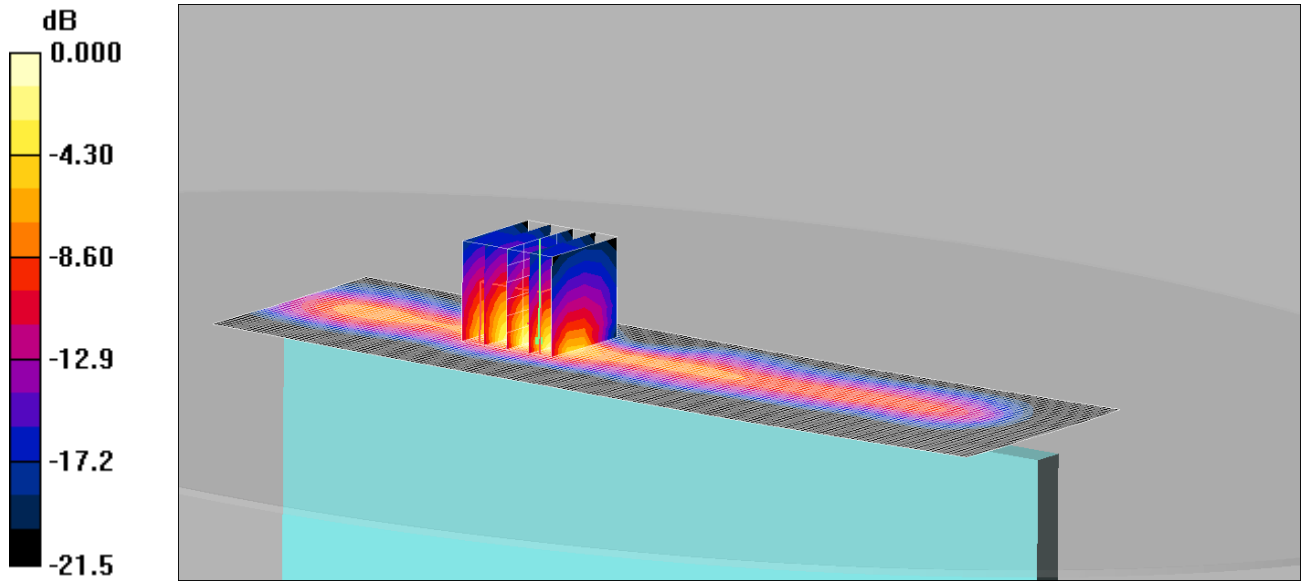

0 dB = 0.552mW/g

Communication System: WCDMA-FDD IV; Frequency: 1732.4 MHz; Duty Cycle: 1:1

Medium: 1800 MHz MSL Medium parameters used (interpolated): $f = 1732.4$ MHz; $\sigma = 1.51$ mho/m; $\epsilon_r = 52.6$; $\rho = 1000$ kg/m³

Phantom section: Flat Section

DASY4 Configuration:

- Probe: ES3DV3 - SN3304; ConvF(4.86, 4.86, 4.86);

- Sensor-Surface: 4mm

(Mechanical Surface Detection)

- Electronics: DAE3 Sn432; Calibrated: 20/08/2014

- Phantom: ELI v5.0; Type: QDOVA002AA;

- Measurement SW: DASY4, V4.7 Build 80; Postprocessing SW: SEMCAD, V1.8 Build 186

Top of EUT Facing Phantom - Middle/Area Scan (51x181x1): Measurement grid: dx=15mm, dy=15mm

Maximum value of SAR (interpolated) = 0.587 mW/g

Top of EUT Facing Phantom - Middle/Zoom Scan (5x5x7) (5x5x7)/Cube 0: Measurement grid: dx=8mm, dy=8mm, dz=5mm

Reference Value = 9.87 V/m; Power Drift = -0.031 dB

Peak SAR (extrapolated) = 1.20 W/kg

SAR(1 g) = 0.494 mW/g; SAR(10 g) = 0.206 mW/g

Maximum value of SAR (measured) = 0.552 mW/g

032: Back of EUT Facing Phantom WCDMA FDD 5 CH4183

Date: 11/06/2015

DUT: Inari; Type: Tablet

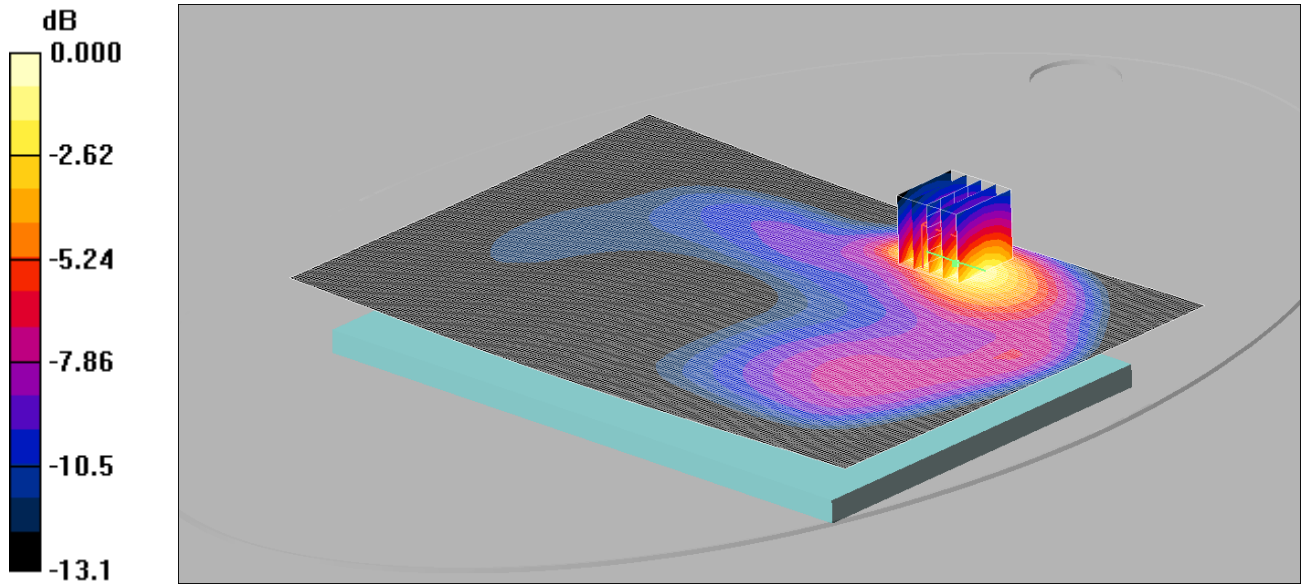

0 dB = 0.596mW/g

Communication System: WCDMA-FDD 5; Frequency: 836.6 MHz; Duty Cycle: 1:1

Medium: 900 MHz MSL Medium parameters used (interpolated): $f = 836.6$ MHz; $\sigma = 1.01$ mho/m; $\epsilon_r = 53.9$; $\rho = 1000$ kg/m³

Phantom section: Flat Section

DASY4 Configuration:

- Probe: ES3DV3 - SN3304; ConvF(6.17, 6.17, 6.17);
- Sensor-Surface: 4mm (Mechanical Surface Detection)
- Electronics: DAE3 Sn432; Calibrated: 20/08/2014
- Phantom: ELI v5.0; Type: QDOVA002AA;
- Measurement SW: DASY4, V4.7 Build 80; Postprocessing SW: SEMCAD, V1.8 Build 186

Back of EUT Facing Phantom - Middle/Area Scan (201x141x1): Measurement grid: dx=15mm, dy=15mm

Maximum value of SAR (interpolated) = 0.584 mW/g

Back of EUT Facing Phantom - Middle/Zoom Scan (5x5x7) (5x5x7)/Cube 0: Measurement grid: dx=8mm, dy=8mm, dz=5mm

Reference Value = 5.28 V/m; Power Drift = 0.090 dB

Peak SAR (extrapolated) = 0.861 W/kg

SAR(1 g) = 0.536 mW/g; SAR(10 g) = 0.324 mW/g

Maximum value of SAR (measured) = 0.596 mW/g

033: Top of EUT Facing Phantom WCDMA FDD 5 CH4183

Date: 11/06/2015

DUT: Inari; Type: Tablet

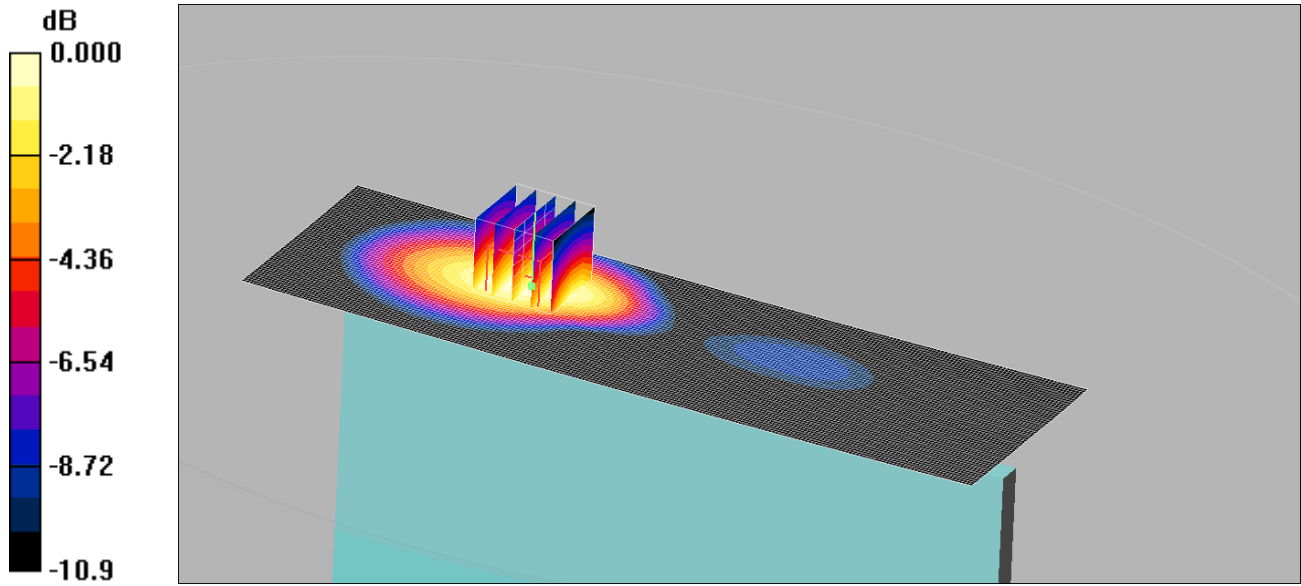

0 dB = 0.387mW/g

Communication System: WCDMA-FDD 5; Frequency: 836.6 MHz; Duty Cycle: 1:1

Medium: 900 MHz MSL Medium parameters used (interpolated): $f = 836.6$ MHz; $\sigma = 1.01$ mho/m; $\epsilon_r = 53.9$; $\rho = 1000$ kg/m³

Phantom section: Flat Section

DASY4 Configuration:

- Probe: ES3DV3 - SN3304; ConvF(6.17, 6.17, 6.17);
- Sensor-Surface: 4mm (Mechanical Surface Detection)
- Electronics: DAE3 Sn432; Calibrated: 20/08/2014
- Phantom: ELI v5.0; Type: QDOVA002AA;
- Measurement SW: DASY4, V4.7 Build 80; Postprocessing SW: SEMCAD, V1.8 Build 186

Top of EUT Facing Phantom - Middle/Area Scan (61x201x1): Measurement grid: dx=15mm, dy=15mm

Maximum value of SAR (interpolated) = 0.384 mW/g

Top of EUT Facing Phantom - Middle/Zoom Scan (5x5x7) (5x5x7)/Cube 0: Measurement grid: dx=8mm, dy=8mm, dz=5mm

Reference Value = 5.92 V/m; Power Drift = 0.015 dB

Peak SAR (extrapolated) = 0.523 W/kg

SAR(1 g) = 0.359 mW/g; SAR(10 g) = 0.240 mW/g

Maximum value of SAR (measured) = 0.387 mW/g

034: Back of EUT Facing Phantom WCDMA FDD 5 CH4132

Date: 11/06/2015

DUT: Inari; Type: Tablet

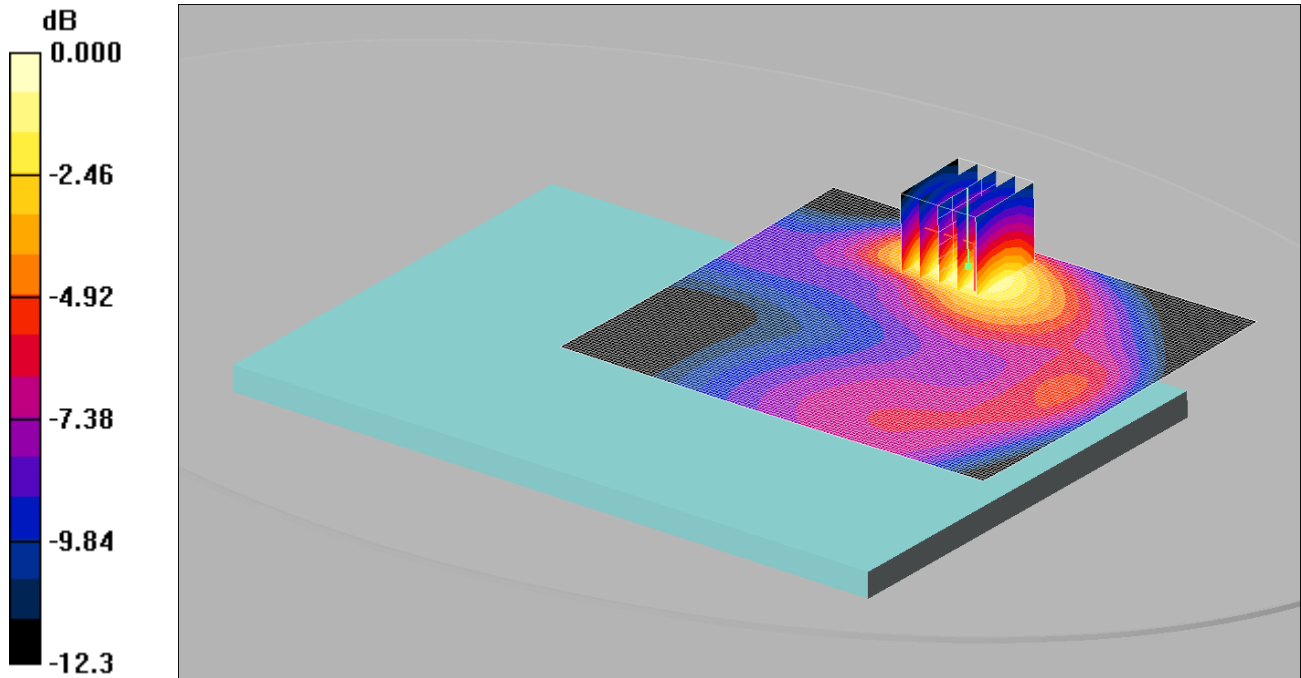

0 dB = 0.502mW/g

Communication System: WCDMA-FDD 5; Frequency: 826.4 MHz; Duty Cycle: 1:1

Medium: 900 MHz MSL Medium parameters used (interpolated): $f = 826.4$ MHz; $\sigma = 1.01$ mho/m; $\epsilon_r = 54$; $\rho = 1000$ kg/m³

Phantom section: Flat Section

DASY4 Configuration:

- Probe: ES3DV3 - SN3304; ConvF(6.17, 6.17, 6.17);
- Sensor-Surface: 4mm (Mechanical Surface Detection)
- Electronics: DAE3 Sn432; Calibrated: 20/08/2014
- Phantom: ELI v5.0; Type: QDOVA002AA;
- Measurement SW: DASY4, V4.7 Build 80; Postprocessing SW: SEMCAD, V1.8 Build 186

Back of EUT Facing Phantom - Low/Area Scan 2 2 (101x121x1): Measurement grid: dx=15mm, dy=15mm

Maximum value of SAR (interpolated) = 0.478 mW/g

Back of EUT Facing Phantom - Low/Zoom Scan (5x5x7) 2 (5x5x7)/Cube 0: Measurement grid: dx=8mm, dy=8mm, dz=5mm

Reference Value = 5.52 V/m; Power Drift = -0.024 dB

Peak SAR (extrapolated) = 0.717 W/kg

SAR(1 g) = 0.457 mW/g; SAR(10 g) = 0.280 mW/g

Maximum value of SAR (measured) = 0.502 mW/g

035: Back of EUT Facing Phantom WCDMA FDD 5 CH4233

Date: 11/06/2015

DUT: Inari; Type: Tablet

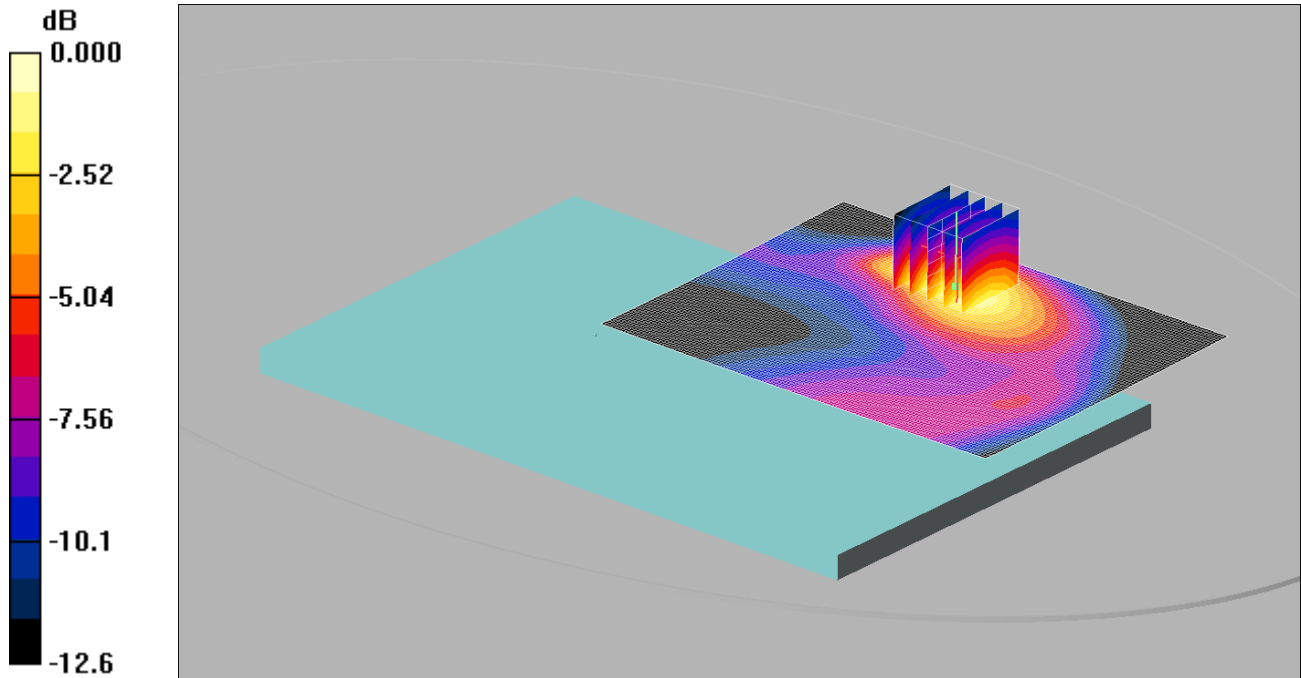

0 dB = 0.458mW/g

Communication System: WCDMA-FDD 5; Frequency: 846.6 MHz; Duty Cycle: 1:1

Medium: 900 MHz MSL Medium parameters used (interpolated): $f = 846.6$ MHz; $\sigma = 1.02$ mho/m; $\epsilon_r = 53.9$; $\rho = 1000$ kg/m³

Phantom section: Flat Section

DASY4 Configuration:

- Probe: ES3DV3 - SN3304; ConvF(6.17, 6.17, 6.17);
- Sensor-Surface: 4mm (Mechanical Surface Detection)
- Electronics: DAE3 Sn432; Calibrated: 20/08/2014
- Phantom: ELI v5.0; Type: QDOVA002AA;
- Measurement SW: DASY4, V4.7 Build 80; Postprocessing SW: SEMCAD, V1.8 Build 186

Back of EUT Facing Phantom - High/Area Scan 2 2 2 (91x121x1): Measurement grid: dx=15mm, dy=15mm

Maximum value of SAR (interpolated) = 0.464 mW/g

Back of EUT Facing Phantom - High/Zoom Scan (5x5x7) 2 (5x5x7)/Cube 0: Measurement grid: dx=8mm, dy=8mm, dz=5mm

Reference Value = 4.34 V/m; Power Drift = 0.004 dB

Peak SAR (extrapolated) = 0.667 W/kg

SAR(1 g) = 0.423 mW/g; SAR(10 g) = 0.258 mW/g

Maximum value of SAR (measured) = 0.458 mW/g

036: Back of EUT Facing Phantom WCDMA FDD 5 CH4183 Reduced Power

Date: 11/06/2015

DUT: Inari; Type: Tablet

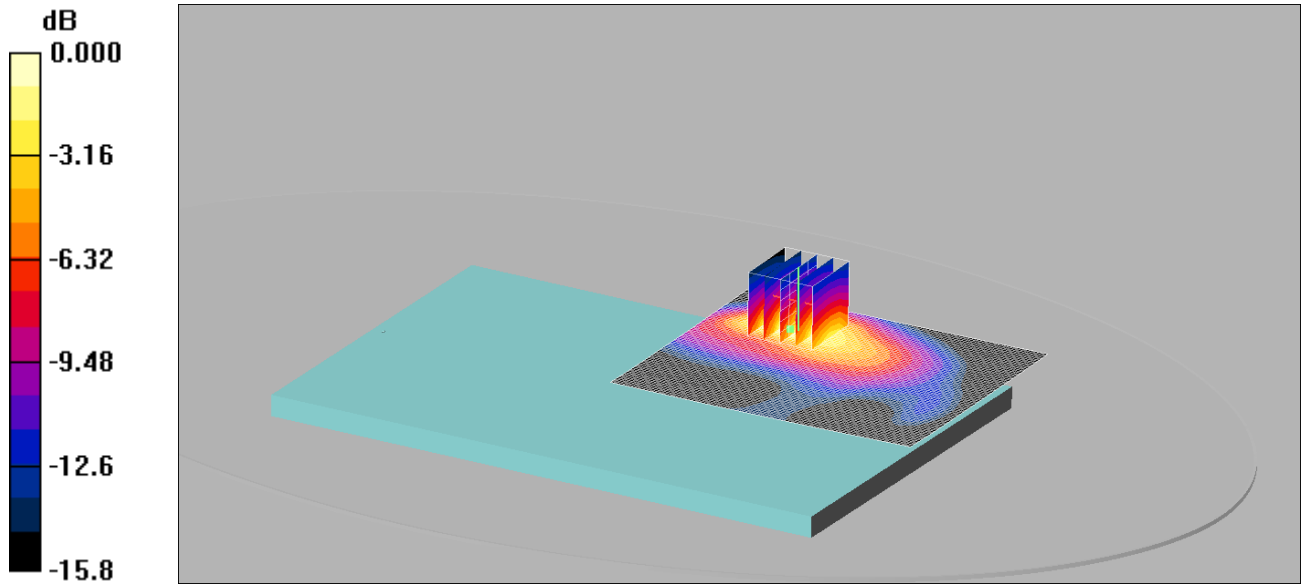

0 dB = 0.355mW/g

Communication System: WCDMA-FDD 5; Frequency: 836.6 MHz; Duty Cycle: 1:1

Medium: 900 MHz MSL Medium parameters used (interpolated): $f = 836.6$ MHz; $\sigma = 1.01$ mho/m; $\epsilon_r = 53.9$; $\rho = 1000$ kg/m³

Phantom section: Flat Section

DASY4 Configuration:

- Probe: ES3DV3 - SN3304; ConvF(6.17, 6.17, 6.17);
- Sensor-Surface: 4mm (Mechanical Surface Detection)
- Electronics: DAE3 Sn432; Calibrated: 20/08/2014
- Phantom: ELI v5.0; Type: QDOVA002AA;
- Measurement SW: DASY4, V4.7 Build 80; Postprocessing SW: SEMCAD, V1.8 Build 186

Back of EUT Facing Phantom - Middle/Area Scan (81x101x1): Measurement grid: dx=15mm, dy=15mm
 Maximum value of SAR (interpolated) = 0.319 mW/g

Back of EUT Facing Phantom - Middle/Zoom Scan (5x5x7) (5x5x7)/Cube 0: Measurement grid: dx=8mm, dy=8mm, dz=5mm

Reference Value = 2.27 V/m; Power Drift = 0.064 dB

Peak SAR (extrapolated) = 0.635 W/kg

SAR(1 g) = 0.308 mW/g; SAR(10 g) = 0.154 mW/g

Maximum value of SAR (measured) = 0.355 mW/g

037: Top of EUT Facing Phantom WCDMA FDD 5 CH 4183 Reduced Power

Date: 11/06/2015

DUT: Inari; Type: Tablet

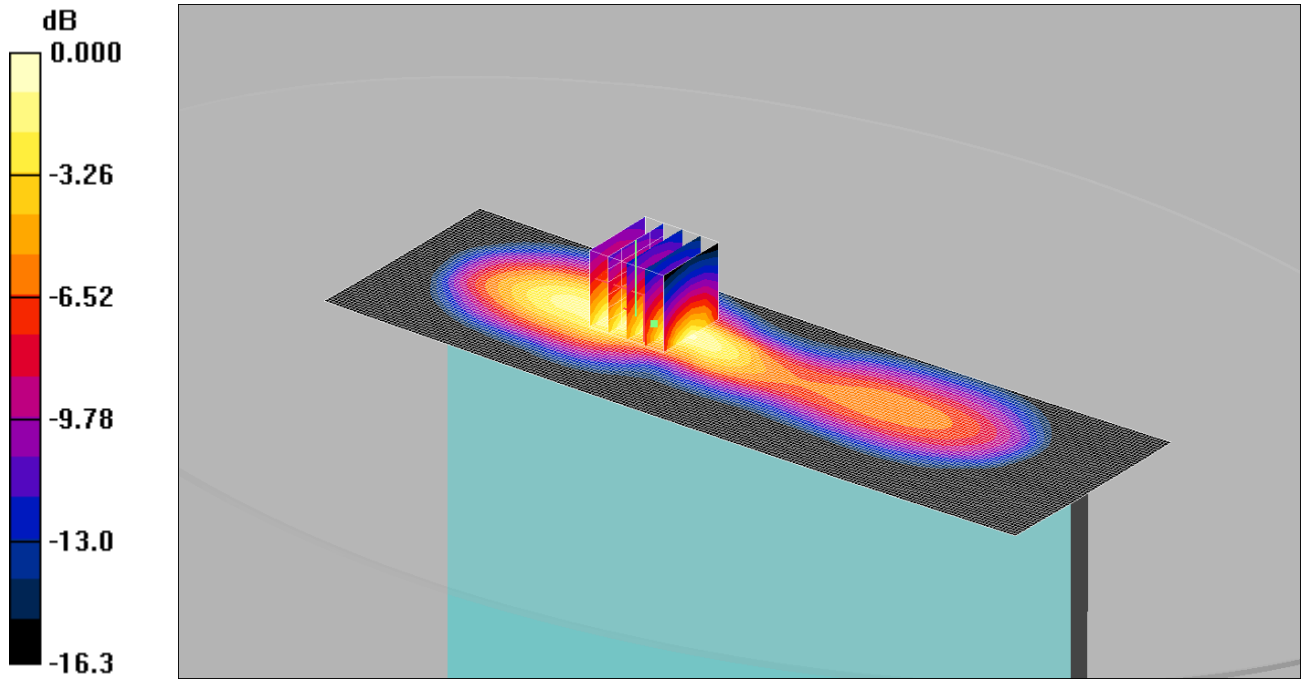

0 dB = 0.177mW/g

Communication System: WCDMA-FDD 5; Frequency: 836.6 MHz; Duty Cycle: 1:1

Medium: 900 MHz MSL Medium parameters used (interpolated): $f = 836.6$ MHz; $\sigma = 1.01$ mho/m; $\epsilon_r = 53.9$; $\rho = 1000$ kg/m³

Phantom section: Flat Section

DASY4 Configuration:

- Probe: ES3DV3 - SN3304; ConvF(6.17, 6.17, 6.17);
- Sensor-Surface: 4mm (Mechanical Surface Detection)
- Electronics: DAE3 Sn432; Calibrated: 20/08/2014
- Phantom: ELI v5.0; Type: QDOVA002AA;
- Measurement SW: DASY4, V4.7 Build 80; Postprocessing SW: SEMCAD, V1.8 Build 186

Top of EUT Facing Phantom - Middle/Area Scan (61x201x1): Measurement grid: dx=15mm, dy=15mm

Maximum value of SAR (interpolated) = 0.157 mW/g

Top of EUT Facing Phantom - Middle/Zoom Scan (5x5x7) (5x5x7)/Cube 0: Measurement grid: dx=8mm, dy=8mm, dz=5mm

Reference Value = 8.21 V/m; Power Drift = 0.046 dB

Peak SAR (extrapolated) = 0.295 W/kg

SAR(1 g) = 0.156 mW/g; SAR(10 g) = 0.085 mW/g

Maximum value of SAR (measured) = 0.177 mW/g

038: Back of EUT Facing Phantom CDMA BC0 CH384

Date: 12/06/2015

DUT: Inari; Type: Tablet

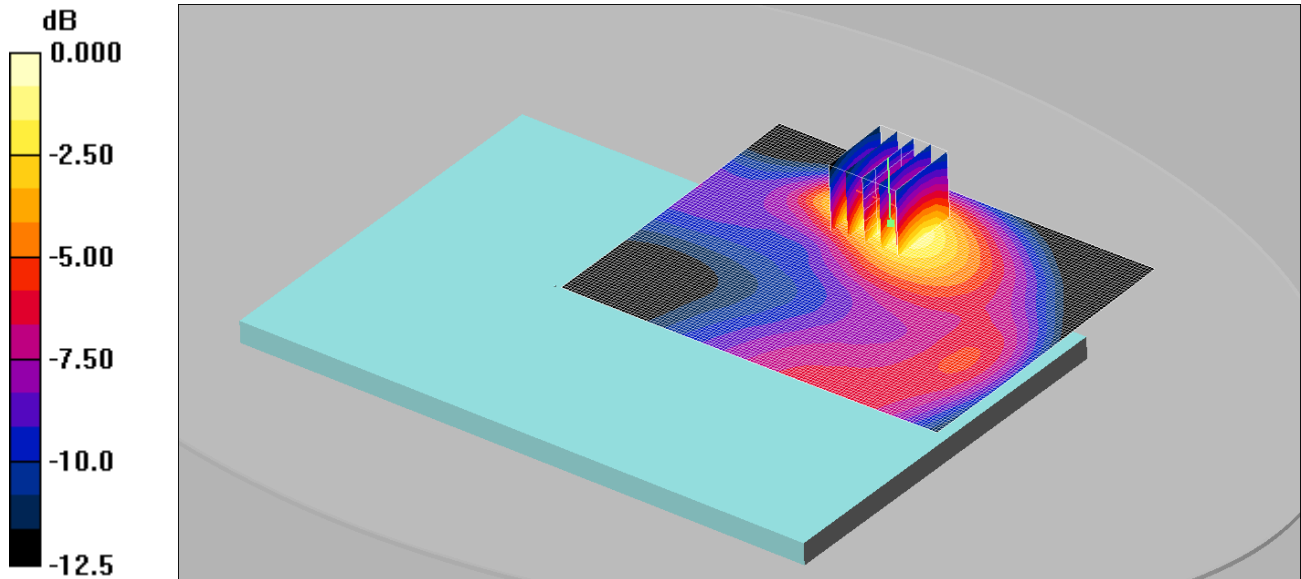

0 dB = 0.527mW/g

Communication System: CDMA 2000 BC0 US; Frequency: 836.52 MHz; Duty Cycle: 1:1

Medium: 900 MHz MSL Medium parameters used (interpolated): f = 836.52 MHz; $\sigma = 1.01$ mho/m; $\epsilon_r = 53.9$; $\rho = 1000$ kg/m³

Phantom section: Flat Section

DASY4 Configuration:

- Probe: ES3DV3 - SN3304; ConvF(6.17, 6.17, 6.17);
Surface Detection)

- Sensor-Surface: 4mm (Mechanical

- Electronics: DAE3 Sn432; Calibrated: 20/08/2014

- Phantom: ELI v5.0; Type: QDOVA002AA;

- Measurement SW: DASY4, V4.7 Build 80; Postprocessing SW: SEMCAD, V1.8 Build 186

Back of EUT Facing Phantom - Middle/Area Scan (91x121x1): Measurement grid: dx=15mm, dy=15mm

Maximum value of SAR (interpolated) = 0.536 mW/g

Back of EUT Facing Phantom - Middle/Zoom Scan (5x5x7) 2 (5x5x7)/Cube 0: Measurement grid: dx=8mm, dy=8mm, dz=5mm

Reference Value = 5.15 V/m; Power Drift = -0.047 dB

Peak SAR (extrapolated) = 0.744 W/kg

SAR(1 g) = 0.479 mW/g; SAR(10 g) = 0.296 mW/g

Maximum value of SAR (measured) = 0.527 mW/g

039: Top of EUT Facing Phantom CDMA BC0 CH384

Date: 12/06/2015

DUT: Inari; Type: Tablet

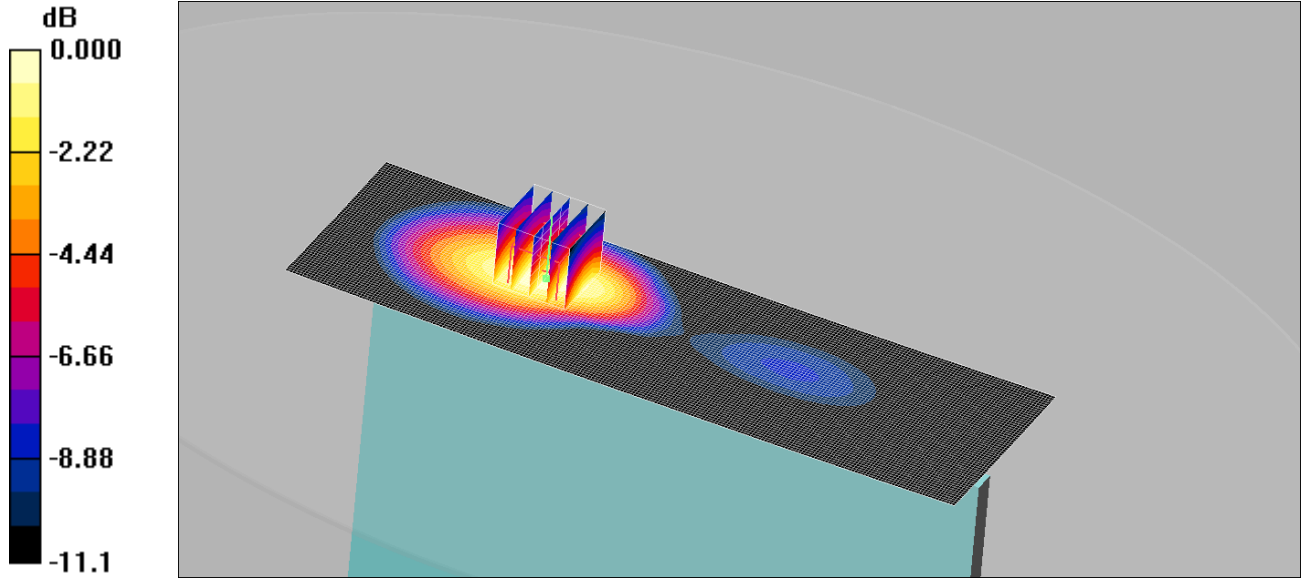

0 dB = 0.423mW/g

Communication System: CDMA 2000 BC0 US; Frequency: 836.52 MHz; Duty Cycle: 1:1

Medium: 900 MHz MSL Medium parameters used (interpolated): f = 836.52 MHz; σ = 1.01 mho/m; ϵ_r = 53.9; ρ = 1000 kg/m³

Phantom section: Flat Section

DASY4 Configuration:

- Probe: ES3DV3 - SN3304; ConvF(6.17, 6.17, 6.17);
(Mechanical Surface Detection)

- Sensor-Surface: 4mm

- Electronics: DAE3 Sn432; Calibrated: 20/08/2014

- Phantom: ELI v5.0; Type: QDOVA002AA;

- Measurement SW: DASY4, V4.7 Build 80; Postprocessing SW: SEMCAD, V1.8 Build 186

Top of EUT Facing Phantom - Middle/Area Scan (61x201x1): Measurement grid: dx=15mm, dy=15mm

Maximum value of SAR (interpolated) = 0.417 mW/g

Top of EUT Facing Phantom - Middle/Zoom Scan (5x5x7) (5x5x7)/Cube 0: Measurement grid: dx=8mm, dy=8mm, dz=5mm

Reference Value = 6.45 V/m; Power Drift = 0.067 dB

Peak SAR (extrapolated) = 0.571 W/kg

SAR(1 g) = 0.393 mW/g; SAR(10 g) = 0.261 mW/g

Maximum value of SAR (measured) = 0.423 mW/g

040: Back of EUT Facing Phantom CDMA BC0 CH1013

Date: 12/06/2015

DUT: Inari; Type: Tablet

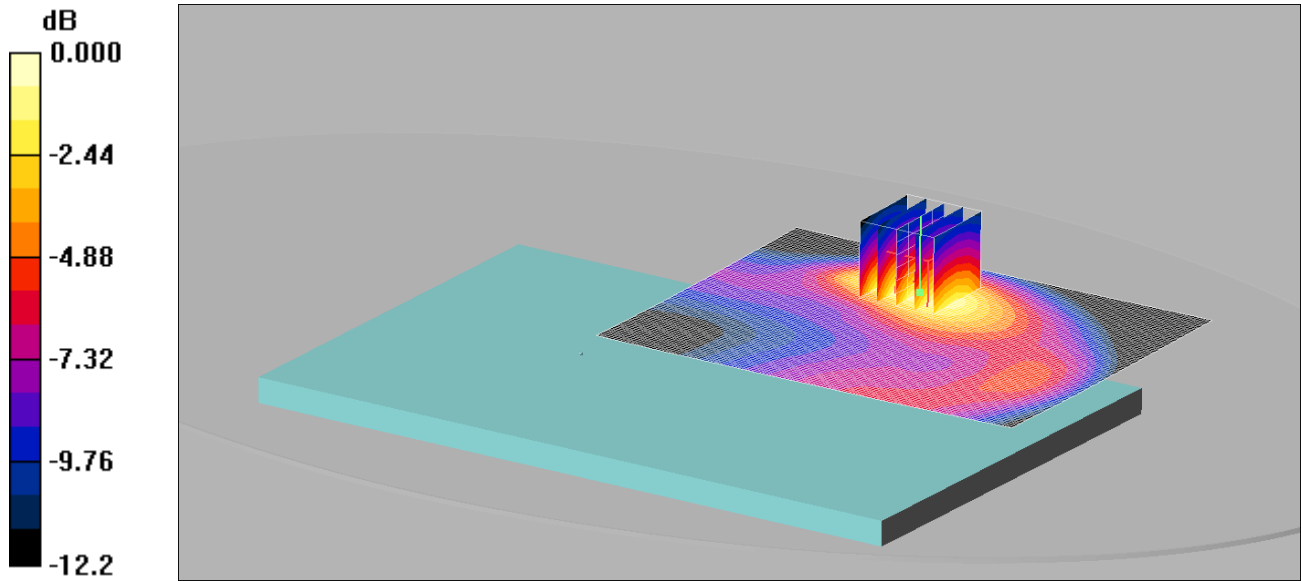

0 dB = 0.563mW/g

Communication System: CDMA 2000 BC0 US; Frequency: 824.7 MHz; Duty Cycle: 1:1

Medium: 900 MHz MSL Medium parameters used (interpolated): $f = 824.7$ MHz; $\sigma = 1.01$ mho/m; $\epsilon_r = 54$; $\rho = 1000$ kg/m³

Phantom section: Flat Section

DASY4 Configuration:

- Probe: ES3DV3 - SN3304; ConvF(6.17, 6.17, 6.17);
(Mechanical Surface Detection)

- Sensor-Surface: 4mm

- Electronics: DAE3 Sn432; Calibrated: 20/08/2014

- Phantom: ELI v5.0; Type: QDOVA002AA;

- Measurement SW: DASY4, V4.7 Build 80; Postprocessing SW: SEMCAD, V1.8 Build 186

Back of EUT Facing Phantom - Low/Area Scan (91x121x1): Measurement grid: dx=15mm, dy=15mm

Maximum value of SAR (interpolated) = 0.561 mW/g

Back of EUT Facing Phantom - Low/Zoom Scan (5x5x7) 2 (5x5x7)/Cube 0: Measurement grid: dx=8mm, dy=8mm, dz=5mm

Reference Value = 12.9 V/m; Power Drift = 0.120 dB

Peak SAR (extrapolated) = 0.809 W/kg

SAR(1 g) = 0.517 mW/g; SAR(10 g) = 0.318 mW/g

Maximum value of SAR (measured) = 0.563 mW/g

041: Back of EUT Facing Phantom CDMA BC0 CH777

Date: 12/06/2015

DUT: Inari; Type: Tablet

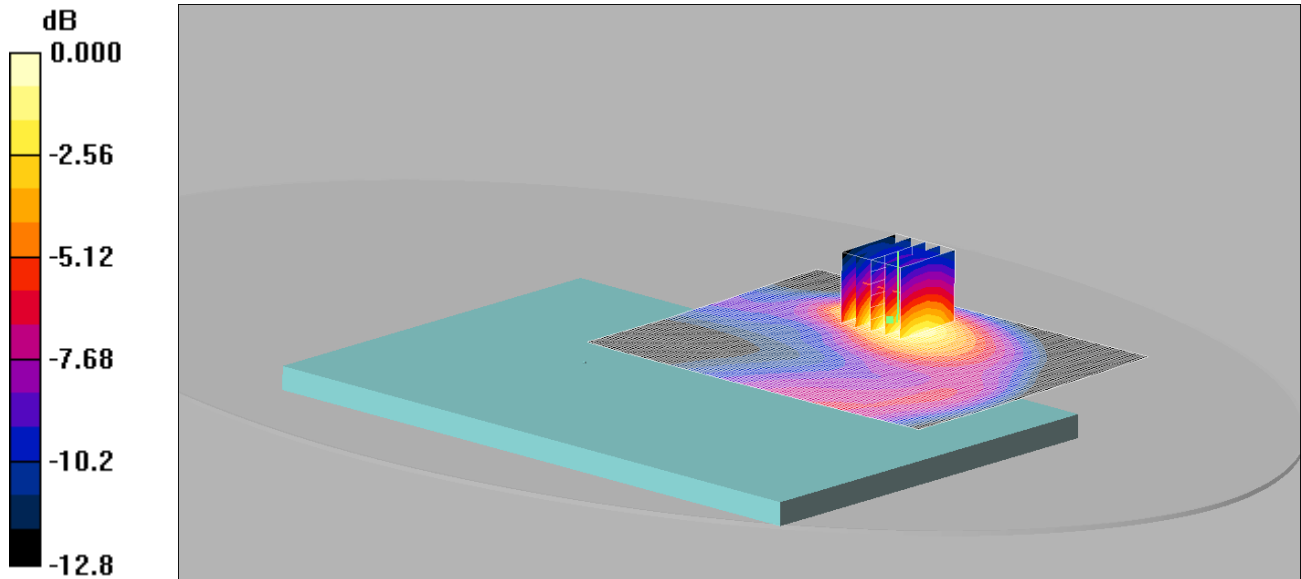

0 dB = 0.518mW/g

Communication System: CDMA 2000 BC0 US; Frequency: 848.31 MHz; Duty Cycle: 1:1

Medium: 900 MHz MSL Medium parameters used (interpolated): $f = 848.31$ MHz; $\sigma = 1.02$ mho/m; $\epsilon_r = 53.9$; $\rho = 1000$ kg/m³

Phantom section: Flat Section

DASY4 Configuration:

- Probe: ES3DV3 - SN3304; ConvF(6.17, 6.17, 6.17);

- Sensor-Surface: 4mm (Mechanical

Surface Detection)

- Electronics: DAE3 Sn432; Calibrated: 20/08/2014

- Phantom: ELI v5.0; Type: QDOVA002AA;

- Measurement SW: DASY4, V4.7 Build 80; Postprocessing SW: SEMCAD, V1.8 Build 186

Back of EUT Facing Phantom - High/Area Scan (91x121x1): Measurement grid: dx=15mm, dy=15mm

Maximum value of SAR (interpolated) = 0.511 mW/g

Back of EUT Facing Phantom - High/Zoom Scan (5x5x7) (5x5x7)/Cube 0: Measurement grid: dx=8mm, dy=8mm, dz=5mm

Reference Value = 4.67 V/m; Power Drift = 0.023 dB

Peak SAR (extrapolated) = 0.747 W/kg

SAR(1 g) = 0.471 mW/g; SAR(10 g) = 0.287 mW/g

Maximum value of SAR (measured) = 0.518 mW/g

042: Back of EUT Facing Phantom CDMA BC0 CH384 Reduced Power

Date: 12/06/2015

DUT: Inari; Type: Tablet

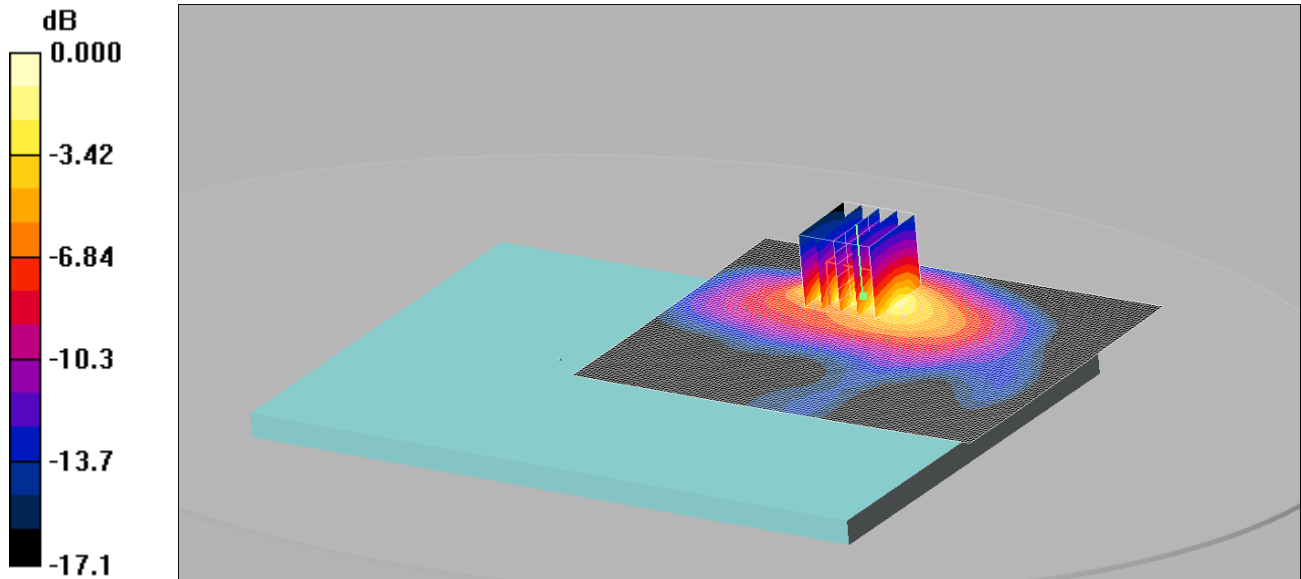

0 dB = 0.335mW/g

Communication System: CDMA 2000 BC0 US; Frequency: 836.52 MHz; Duty Cycle: 1:1

Medium: 900 MHz MSL Medium parameters used (interpolated): $f = 836.52$ MHz; $\sigma = 1.01$ mho/m; $\epsilon_r = 53.9$; $\rho = 1000$ kg/m³

Phantom section: Flat Section

DASY4 Configuration:

- Probe: ES3DV3 - SN3304; ConvF(6.17, 6.17, 6.17);

- Sensor-Surface: 4mm (Mechanical

Surface Detection)

- Electronics: DAE3 Sn432; Calibrated: 20/08/2014

- Phantom: ELI v5.0; Type: QDOVA002AA;

- Measurement SW: DASY4, V4.7 Build 80; Postprocessing SW: SEMCAD, V1.8 Build 186

Back of EUT Facing Phantom - Middle/Area Scan (91x121x1): Measurement grid: dx=15mm, dy=15mm

Maximum value of SAR (interpolated) = 0.320 mW/g

Back of EUT Facing Phantom - Middle/Zoom Scan (5x5x7) 2 (5x5x7)/Cube 0: Measurement grid: dx=8mm, dy=8mm, dz=5mm

Reference Value = 2.03 V/m; Power Drift = 0.176 dB

Peak SAR (extrapolated) = 0.579 W/kg

SAR(1 g) = 0.273 mW/g; SAR(10 g) = 0.135 mW/g

Maximum value of SAR (measured) = 0.335 mW/g

043: Top of EUT Facing Phantom CDMA BC0 CH384 Reduced Power

Date: 12/06/2015

DUT: Inari; Type: Tablet

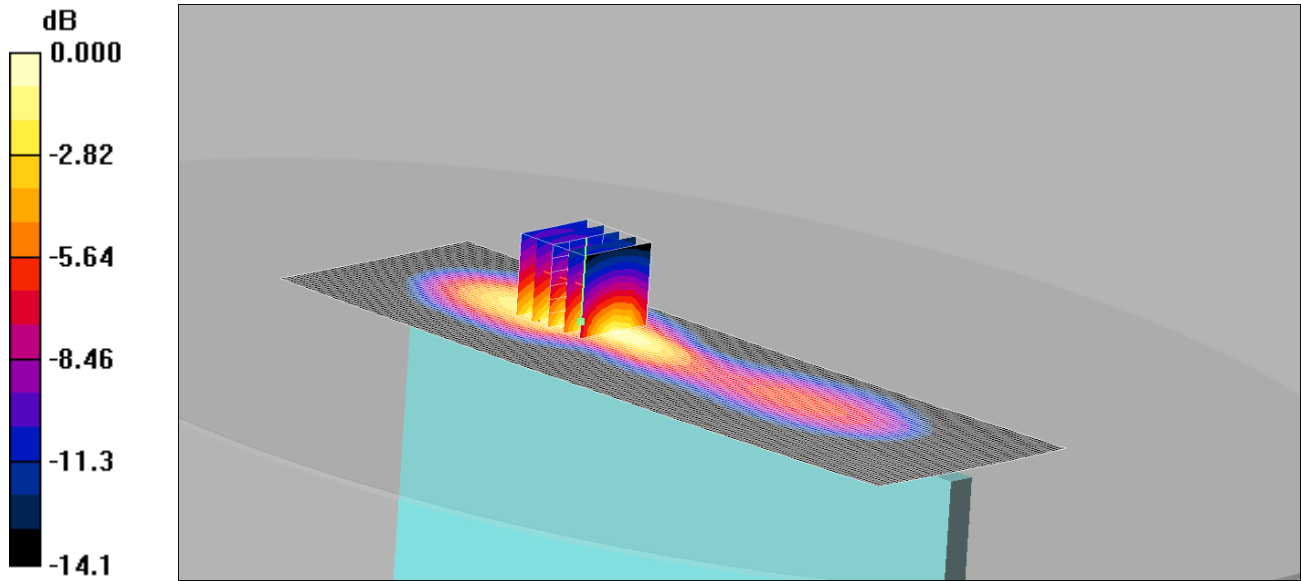

0 dB = 0.167mW/g

Communication System: CDMA 2000 BC0 US; Frequency: 836.52 MHz; Duty Cycle: 1:1

Medium: 900 MHz MSL Medium parameters used (interpolated): $f = 836.52$ MHz; $\sigma = 1.01$ mho/m; $\epsilon_r = 53.9$; $\rho = 1000$ kg/m³

Phantom section: Flat Section

DASY4 Configuration:

- Probe: ES3DV3 - SN3304; ConvF(6.17, 6.17, 6.17);
(Mechanical Surface Detection)

- Sensor-Surface: 4mm

- Electronics: DAE3 Sn432; Calibrated: 20/08/2014

- Phantom: ELI v5.0; Type: QDOVA002AA;

- Measurement SW: DASY4, V4.7 Build 80; Postprocessing SW: SEMCAD, V1.8 Build 186

Top of EUT Facing Phantom - Middle/Area Scan (61x201x1): Measurement grid: dx=15mm, dy=15mm

Maximum value of SAR (interpolated) = 0.149 mW/g

Top of EUT Facing Phantom - Middle/Zoom Scan (5x5x7) (5x5x7)/Cube 0: Measurement grid: dx=8mm, dy=8mm, dz=5mm

Reference Value = 8.57 V/m; Power Drift = -0.016 dB

Peak SAR (extrapolated) = 0.273 W/kg

SAR(1 g) = 0.147 mW/g; SAR(10 g) = 0.081 mW/g

Maximum value of SAR (measured) = 0.167 mW/g

044: Back of EUT Facing Phantom CDMA BC1 CH600

Date: 30/06/2015

DUT: Inari; Type: Tablet

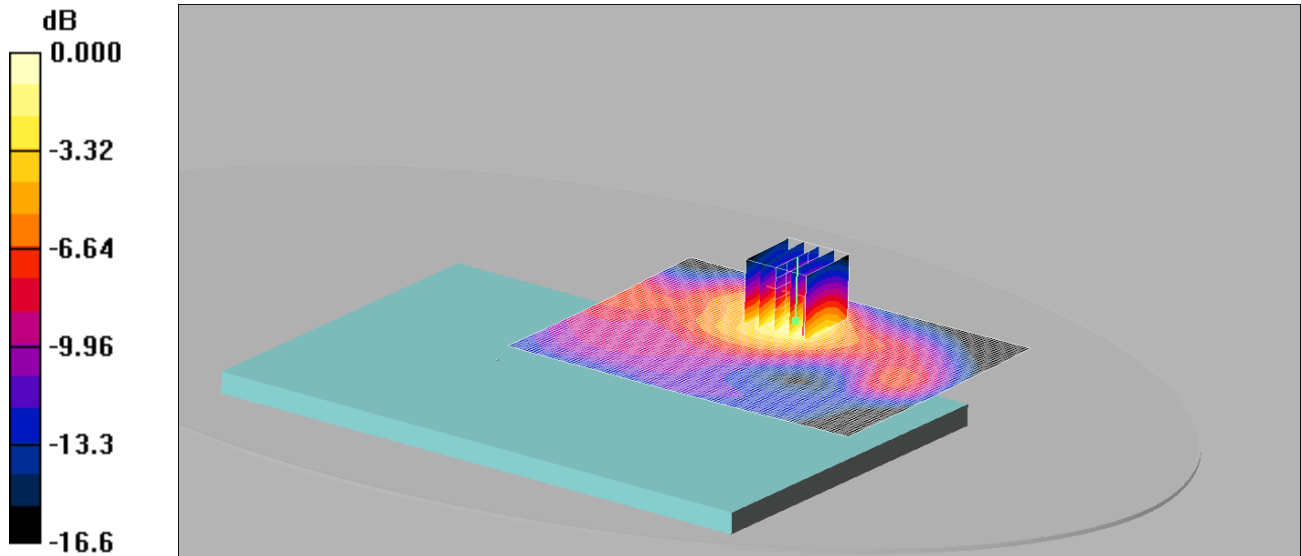

0 dB = 0.860mW/g

Communication System: CDMA 2000 BC1 US; Frequency: 1880 MHz; Duty Cycle: 1:1

Medium: 1900 MHz MSL Medium parameters used (interpolated): $f = 1880$ MHz; $\sigma = 1.47$ mho/m; $\epsilon_r = 52.5$; $\rho = 1000$ kg/m³

Phantom section: Flat Section

DASY4 Configuration:

- Probe: ES3DV3 - SN3304; ConvF(4.69, 4.69, 4.69);

- Sensor-Surface: 4mm

(Mechanical Surface Detection)

- Electronics: DAE3 Sn432; Calibrated: 20/08/2014

- Phantom: ELI v5.0; Type: QDOVA002AA;

- Measurement SW: DASY4, V4.7 Build 80; Postprocessing SW: SEMCAD, V1.8 Build 186

Back of EUT Facing Phantom - Middle/Area Scan (91x121x1): Measurement grid: dx=15mm, dy=15mm

Maximum value of SAR (interpolated) = 0.850 mW/g

Back of EUT Facing Phantom - Middle/Zoom Scan (5x5x7) (5x5x7)/Cube 0: Measurement grid: dx=8mm, dy=8mm, dz=5mm

Reference Value = 15.7 V/m; Power Drift = 0.030 dB

Peak SAR (extrapolated) = 1.34 W/kg

SAR(1 g) = 0.770 mW/g; SAR(10 g) = 0.427 mW/g

Maximum value of SAR (measured) = 0.860 mW/g

045: Top of EUT Facing Phantom CDMA BC1 CH600

Date: 30/06/2015

DUT: Inari; Type: Tablet

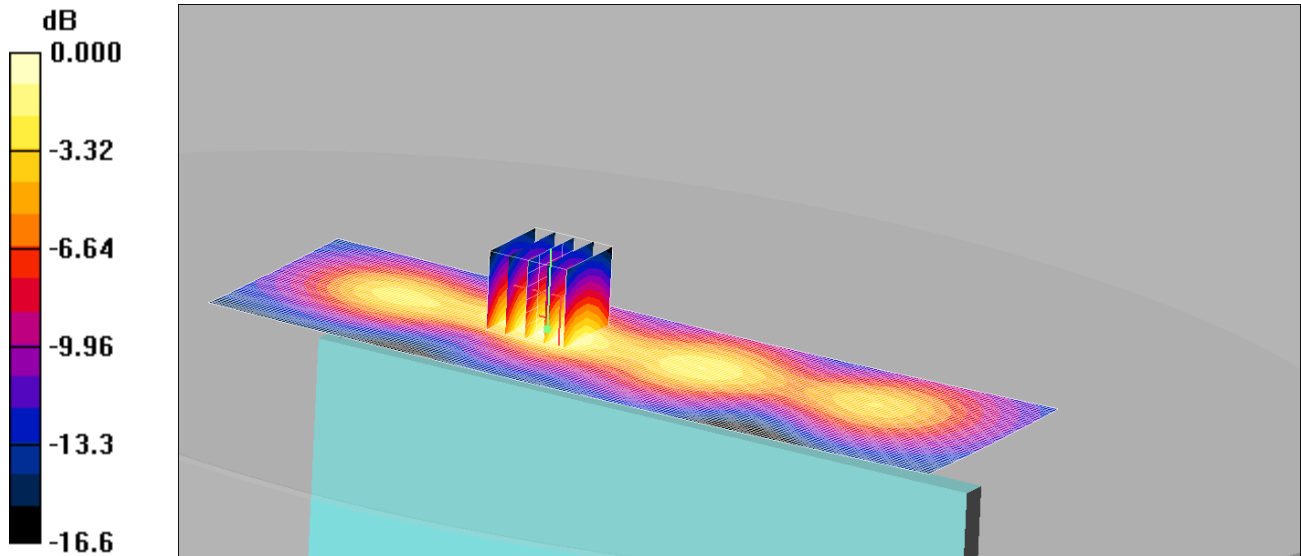

0 dB = 0.593mW/g

Communication System: CDMA 2000 BC1 US; Frequency: 1880 MHz; Duty Cycle: 1:1

Medium: 1900 MHz MSL Medium parameters used (interpolated): $f = 1880$ MHz; $\sigma = 1.47$ mho/m; $\epsilon_r = 52.5$; $\rho = 1000$ kg/m³

Phantom section: Flat Section

DASY4 Configuration:

- Probe: ES3DV3 - SN3304; ConvF(4.69, 4.69, 4.69);

- Sensor-Surface: 4mm

(Mechanical Surface Detection)

- Electronics: DAE3 Sn432; Calibrated: 20/08/2014

- Phantom: ELI v5.0; Type: QDOVA002AA;

- Measurement SW: DASY4, V4.7 Build 80; Postprocessing SW: SEMCAD, V1.8 Build 186

Top of EUT Facing Phantom - Middle/Area Scan (61x201x1): Measurement grid: dx=15mm, dy=15mm

Maximum value of SAR (interpolated) = 0.586 mW/g

Top of EUT Facing Phantom - Middle/Zoom Scan (5x5x7) (5x5x7)/Cube 0: Measurement grid: dx=8mm, dy=8mm, dz=5mm

Reference Value = 9.59 V/m; Power Drift = -0.045 dB

Peak SAR (extrapolated) = 0.882 W/kg

SAR(1 g) = 0.533 mW/g; SAR(10 g) = 0.302 mW/g

Maximum value of SAR (measured) = 0.593 mW/g

046: Back of EUT Facing Phantom CDMA BC1 CH25

Date: 30/06/2015

DUT: Inari; Type: Tablet

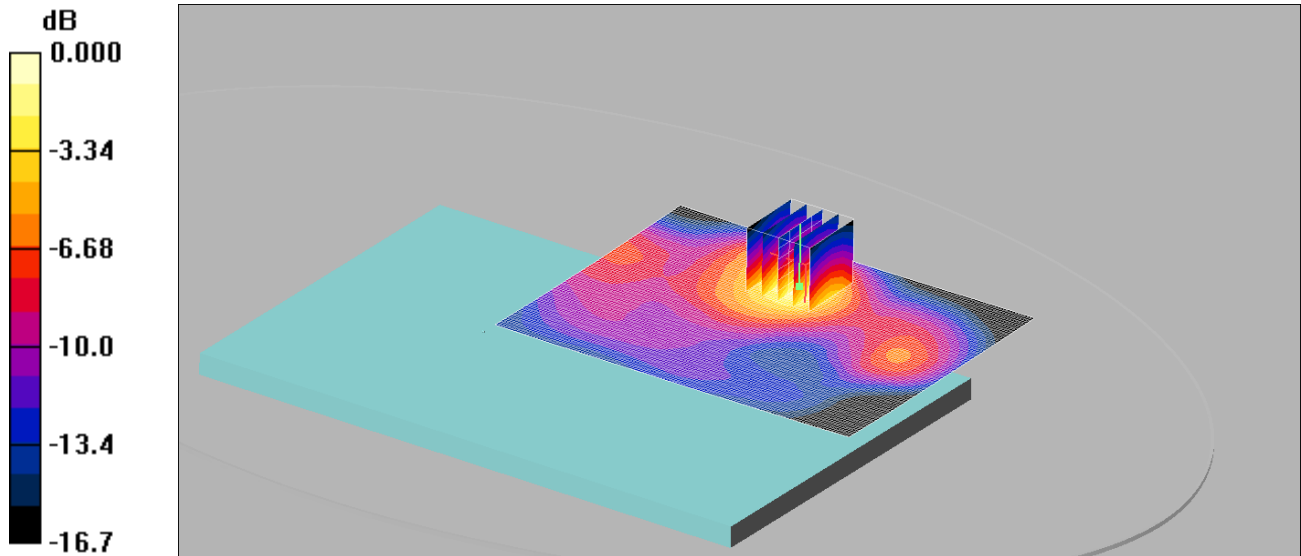

0 dB = 0.906mW/g

Communication System: CDMA 2000 BC1 US; Frequency: 1851.25 MHz; Duty Cycle: 1:1

Medium: 1900 MHz MSL Medium parameters used (interpolated): $f = 1851.25$ MHz; $\sigma = 1.44$ mho/m; $\epsilon_r = 52.7$; $\rho = 1000$ kg/m³

Phantom section: Flat Section

DASY4 Configuration:

- Probe: ES3DV3 - SN3304; ConvF(4.69, 4.69, 4.69);

- Sensor-Surface: 4mm

(Mechanical Surface Detection)

- Electronics: DAE3 Sn432; Calibrated: 20/08/2014

- Phantom: ELI v5.0; Type: QDOVA002AA;

- Measurement SW: DASY4, V4.7 Build 80; Postprocessing SW: SEMCAD, V1.8 Build 186

Back of EUT Facing Phantom - Low/Area Scan (91x121x1): Measurement grid: dx=15mm, dy=15mm

Maximum value of SAR (interpolated) = 0.908 mW/g

Back of EUT Facing Phantom - Low/Zoom Scan (5x5x7) (5x5x7)/Cube 0: Measurement grid: dx=8mm, dy=8mm, dz=5mm

Reference Value = 15.1 V/m; Power Drift = -0.404 dB

Peak SAR (extrapolated) = 1.41 W/kg

SAR(1 g) = 0.817 mW/g; SAR(10 g) = 0.449 mW/g

Maximum value of SAR (measured) = 0.906 mW/g

047: Back of EUT Facing Phantom CDMA BC1 CH1175

Date: 30/06/2015

DUT: Inari; Type: Tablet

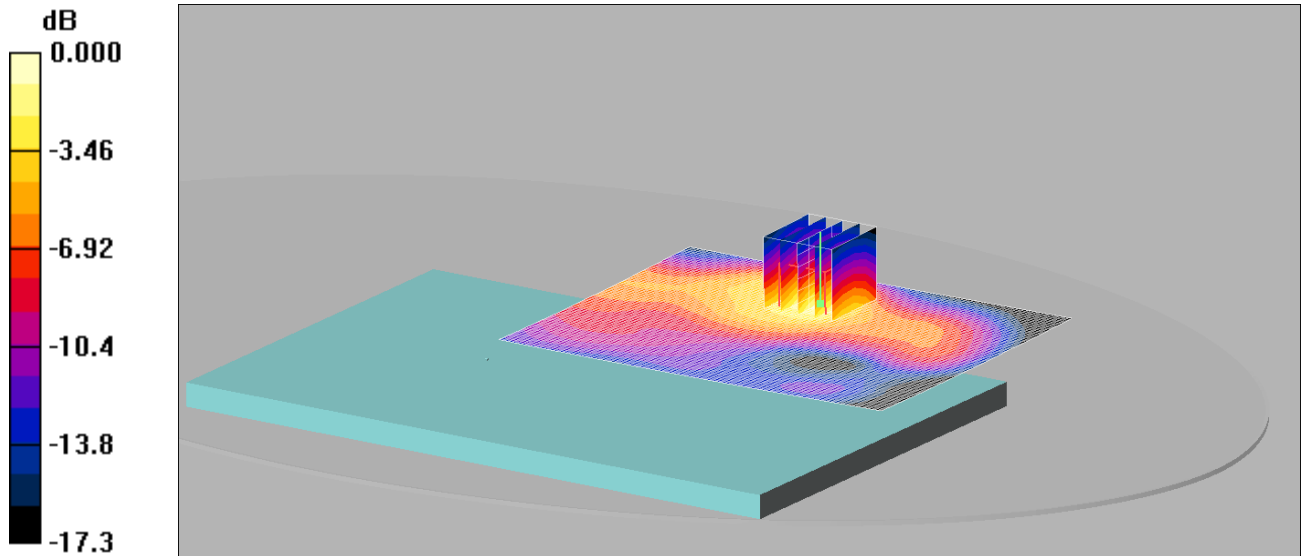

0 dB = 0.766mW/g

Communication System: CDMA 2000 BC1 US; Frequency: 1908.75 MHz; Duty Cycle: 1:1

Medium: 1900 MHz MSL Medium parameters used (interpolated): $f = 1908.75$ MHz; $\sigma = 1.5$ mho/m; $\epsilon_r = 52.4$; $\rho = 1000$ kg/m³

Phantom section: Flat Section

DASY4 Configuration:

- Probe: ES3DV3 - SN3304; ConvF(4.69, 4.69, 4.69);

- Sensor-Surface: 4mm

(Mechanical Surface Detection)

- Electronics: DAE3 Sn432; Calibrated: 20/08/2014

- Phantom: ELI v5.0; Type: QDOVA002AA;

- Measurement SW: DASY4, V4.7 Build 80; Postprocessing SW: SEMCAD, V1.8 Build 186

Back of EUT Facing Phantom - High/Area Scan (91x121x1): Measurement grid: dx=15mm, dy=15mm

Maximum value of SAR (interpolated) = 0.747 mW/g

Back of EUT Facing Phantom - High/Zoom Scan (5x5x7) (5x5x7)/Cube 0: Measurement grid: dx=8mm, dy=8mm, dz=5mm

Reference Value = 15.4 V/m; Power Drift = -0.032 dB

Peak SAR (extrapolated) = 1.22 W/kg

SAR(1 g) = 0.693 mW/g; SAR(10 g) = 0.381 mW/g

Maximum value of SAR (measured) = 0.766 mW/g