



<b>SAR TEST REPORT</b> <b>FCC 47 CFR Part 2.1093</b> <b>Industry Canada RSS-102</b> <b>RF-Exposure evaluation of portable equipment</b>	
<b>Report Reference No.</b> .....	G0M-1407-3981-TFC093SR-V01
<b>Testing Laboratory</b> .....	EurofinsProduct Service GmbH
Address .....	Storkower Str. 38c 15526 Reichenwalde Germany
Accreditation .....	<div style="display: flex; justify-content: center; align-items: center;">   </div> <p style="text-align: center; font-size: small;">A2LA Accredited Testing Laboratory, Certificate No.: 1983.01 FCC Filed Test Laboratory, Reg.-No.: 96970 IC OATS Filing assigned code: 3470A</p>
<b>Applicant's name</b> .....	Aava Mobile Oy
Address .....	Nahkatehtaankatu 2 90130Oulu Finland
<b>Test specification:</b>	
Standard.....	FCC 47 CFR Part 2 §2.1093 FCC OET Bulletin 65 Supplement C 01-01 IEEE Std. 1528-2003 IEEE Std. 1528 - 2013 IC RSS-102 Issue 4 Safety Code 6 (2009)
Non-standard test method.....	None
Test scope.....	complete Radio compliance test
<b>Equipment under test (EUT):</b>	
Product description	Tablet PC
Model No.	INARI10-LTBN-1
Additional Model(s)	None
Brand Name(s)	Aava Mobile
Hardware version	EV2.1
Firmware / Software version	WIN8-INARI8-R1.0-015
Contains	FCC-ID: QISME936 <span style="float: right;">IC: 6369A-ME936</span>
<b>Test result</b>	<b>Passed</b>

**Possible test case verdicts:**

- neither assessed nor tested.....: N/N
- required by standard but not appl. to test object.....: N/A
- required by standard but not tested.....: N/T
- not required by standard for the test object.....: N/R
- test object does meet the requirement.....: P (Pass)
- test object does not meet the requirement.....: F (Fail)

**Testing:**

Date of receipt of test item .....: 2014-07-10

Date (s) of performance of tests .....: 2014-07-23 - 2014-09-27

Compiled by .....: Matthias Handrik

Tested by (+ signature) .....: Matthias Handrik  
 (Responsible for Test)

Approved by (+ signature).....: Toralf Jahn

Date of issue .....: 2014-10-10

Total number of pages .....: 217

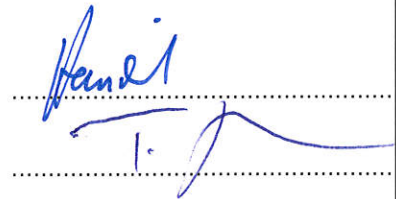
**General remarks:**

**The test results presented in this report relate only to the object tested.**  
**The results contained in this report reflect the results for this particular model and serial number. It is the responsibility of the manufacturer to ensure that all production models meet the intent of the requirements detailed within this report.**

This report shall not be reproduced, except in full, without the written approval of the Issuing testing laboratory.

**Additional comments:**

---

## Version History

Version	Issue Date	Remarks	Revisedby
01	2014-10-10	Initial Release	

---

## REPORT INDEX

<b>1</b>	<b>EQUIPMENT (TEST ITEM) DESCRIPTION</b>	<b>6</b>
1.1	Equipment setup photos	8
1.2	Reference Documents	12
1.3	Supporting Equipment Used During Testing	13
1.4	Supported standalone operating modes	14
1.5	Conducted Power Values	15
1.6	Standalone Operational Mode Test Exclusion	42
1.7	Supported concurrent (multi-transmitter) operating modes	43
1.8	Supported use cases	44
1.9	Proximity Sensors	44
1.10	Radio Test Modes	46
1.11	Test Positions	48
1.12	Test Equipment Used During Testing	49
<b>2</b>	<b>RESULT SUMMARY</b>	<b>50</b>
<b>3</b>	<b>DEFINITIONS</b>	<b>51</b>
3.1	Controlled Exposure	51
3.2	Uncontrolled Exposure	51
3.3	Localized SAR	51
<b>4</b>	<b>LOCALIZED SAR MEASUREMENT EQUIPMENT</b>	<b>52</b>
4.1	Complete SAR DASY5 Measurement System	52
4.2	Robot Arm	54
4.3	Data Acquisition Electronics	54
4.4	Isotropic E-Field Probe $\leq 3$ GHz	55
4.5	Isotropic E-Field Probe $\leq 6$ GHz	56
4.6	Test phantom and positioner	57
4.7	System Validation Dipoles	58
<b>5</b>	<b>SINGLE-BAND SAR MEASUREMENT</b>	<b>60</b>
5.1	General measurement description	60
5.2	SAR measurement description	60
5.3	Reference lines and points for Handsets	61
5.4	Test positions relative to the Head	62
5.5	Test positions relative to the human body	63
5.6	Measurement Uncertainty	64

<b>6</b>	<b>TEST CONDITIONS AND RESULTS</b>	<b>66</b>
6.1	Test Conditions and Results – Tissue Validation	66
6.2	Test Conditions and Results – System Validation	68
6.3	Test Conditions and Results – Standalone SAR Measurement	70
6.4	Test Conditions and Results – Multi-transmitter SAR Result	73
ANNEX A	Equipment photos	76
ANNEX B	Calibration Documents	79
ANNEX C	System Validation Reports	185
ANNEX D	SAR Measurement Reports	208

## 1 Equipment (Test item) Description

<b>Description</b>	Tablet PC
<b>Model</b>	INARI10-LTBN-1
<b>Additional Model(s)</b>	None
<b>Brand Name(s)</b>	Aava Mobile
<b>Serial number</b>	None
<b>Hardware version</b>	EV2.1
<b>Software / Firmware version</b>	WIN8-INARI8-R1.0-015
<b>Contains FCC-ID</b>	QISME936
<b>Contains IC</b>	6369A-ME936
<b>Equipment type</b>	End product
<b>Prototype or production unit</b>	Identical Prototype
<b>Device category</b>	Handset
<b>Environment</b>	General public
<b>Radio technologies</b>	Bluetooth BR+EDR WLAN b/g/n (2.4 GHz), 20/40 MHz, 2 Spatial Stream WLAN a/n (5 GHz), 20/40 MHz, 2 Spatial Stream GSM/GRPS850, Power Class 4, Multislot Class 33 EGPRS850, Power Class E2, Multislot Class 33 GSM/GRPS1900, Power Class 1, Multislot Class 33 EGPRS1900, Power Class E2, Multislot Class 33 UMTS FDDII, Power Class 3 UMTS FDDIV, Power Class 3 UMTS FDDV, Power Class 3 LTE FDD2 LTE FDD4 LTE FDD5 LTE FDD13 LTE FDD17
<b>Operating frequency ranges</b>	GSM 850 : 824 - 849 MHz PCS 1900 : 1850 - 1990 MHz FDD II : 1850 MHz - 1910 MHz FDD IV: 1710 MHz - 1755 MHz FDD V : 824 MHz - 849 MHz FDD 2 : 1850 MHz - 1910 MHz FDD 4 : 1710 MHz - 1755 MHz FDD 5 : 824 MHz - 849 MHz FDD 13 : 777 MHz - 787 MHz FDD 17 : 704 MHz - 716 MHz Bluetooth : 2402 MHz - 2480 MHz WLAN : 2412 MHz – 2462 MHz / (20MHz) WLAN : 2422 MHz – 2452 MHz / (40MHz) WLAN : 5180 MHz – 5240 MHz / (20MHz) WLAN : 5260 MHz – 5320 MHz / (20MHz)

	WLAN : 5500 MHz – 5700 MHz / (20MHz), excluding Channels 120 - 128 WLAN : 5745 MHz – 5825 MHz / (20MHz) WLAN : 5190 MHz – 5230 MHz / (40MHz) WLAN : 5270 MHz – 5310 MHz / (40MHz) WLAN : 5510 MHz – 5670 MHz / (40MHz), excluding Channels 120 - 128 WLAN : 5755 MHz – 5795 MHz / (40MHz)	
<b>Antenna: Cellular(TX) MAIN</b>	Type	integrated
	Model	flexible
	Manufacturer	Aava Mobile
	Gain	2.34 dBi
<b>Antenna: Cellular (RX) Diversity</b>	Type	integrated
	Model	flexible
	Manufacturer	Aava Mobile
	Gain	2.34 dBi
<b>Antenna: MAIN WLAN</b>	Type	integrated
	Model	ceramic
	Manufacturer	Aava Mobile
	Gain	1.9 dBi
<b>Antenna: AUX WLAN</b>	Type	integrated
	Model	ceramic
	Manufacturer	Aava Mobile
	Gain	1.9 dBi
<b>Power supply</b>	$V_{NOM}$	3.7 VDC (Lithium Battery)
<b>Accessories</b>	None	
<b>Manufacturer</b>	ecom instruments GmbH Industriestaße 2 97959 Assamstadt Germany	

**1.2 Reference Documents**

<b>Document</b>
KDB Publication 447498 : Mobile and Portable Device RF Exposure Procedures and Equipment Authorization Policies
KDB Publication 616217: SAR Evaluation Considerations for Laptop, Notebook, Netbook and Tablet Computers
KDB Publication 648474 : SAR Evaluation Considerations for Wireless Handsets
KDB Publication 648474 : Review and Approval Policies for SAR Evaluation of Handsets with Multiple Transmitters and Antennas
KDB Publication 865664 : SAR measurement procedures for devices operating between 100 MHz to 6 GHz
KDB Publication 941225: SAR Measurement Procedures for 3G Devices
KDB Publication 941225: 3GPP R6 HSPA and R7 HSPA+ SAR Guidance
KDB Publication 941225: Recommended SAR Test Reduction Procedures for GSM/GPRS/EDGE
KDB Publication 941225: SAR Test Consideration for LTE Handsets and Data Modems
KDB Publication 248227 : SAR Measurement Procedures for 802.11 a/b/g Transmitters
KDB Publication 450824 : SAR Probe Calibration and System Verification considerations for measurements from 150 MHz to 3 GHz
KDB Publication 865664: RF Exposure Reporting



### 1.3 Supporting Equipment Used During Testing

Product Type*	Device	Manufacturer	Model No.	Comments
SIM	Communication tester	Rohde & Schwarz	CMU 200	-
SIM	Communication tester	Rohde & Schwarz	CMW	-
SIM : Simulator (Not Subjected to Test)				

**1.4 Supported standalone operating modes**

Mode	Modulation	Frequency range	Duty cycle
GSM/GPRS 850	GMSK	824.2 – 848 MHz	up to 50 %
EGPRS 850	GMSK, 8-PSK	824.2 – 848 MHz	up to 50 %
GSM/GPRS 1900	GMSK	1850.2 – 1909.8 MHz	up to 50 %
EGPRS 1900	GMSK, 8-PSK	1850.2 – 1909.8 MHz	up to 50 %
FDD II (RMC)	QPSK	1852.4 – 1907.6 MHz	1.0
FDD II (HSDPA)	QPSK	1852.4 – 1907.6 MHz	1.0
FDD II (HSUPA)	QPSK	1852.4 – 1907.6 MHz	1.0
FDD II (DC-HSDPA)	QPSK	1852.4 – 1907.6 MHz	1.0
FDD IV (RMC)	QPSK	1710.0 - 1755.0 MHz	1.0
FDD IV (HSDPA)	QPSK	1710.0 – 1755.0 MHz	1.0
FDD IV (HSUPA)	QPSK	1710.0 – 1755.0 MHz	1.0
FDD IV (DC-HSDPA)	QPSK	1710.0 – 1755.0 MHz	1.0
FDD V (RMC)	QPSK	826.4 – 846.6 MHz	1.0
FDD V (HSDPA)	QPSK	826.4 – 846.6 MHz	1.0
FDD V (HSUPA)	QPSK	826.4 – 846.6 MHz	1.0
FDD V (DC-HSDPA)	QPSK	826.4 – 846.6 MHz	1.0
FDD 2 (1.4-20 MHz)	QPSK	1850.7 – 1909.3 MHz	1.0
FDD 2 (1.4-20 MHz)	16-QAM	1850.7 – 1909.3 MHz	1.0
FDD 4 (1.4-20 MHz)	QPSK	1710.7 – 1754.3 MHz	1.0
FDD 4 (1.4-20 MHz)	16-QAM	1710.7 – 1754.3 MHz	1.0
FDD 5 (1.4-10 MHz)	QPSK	824.7 – 848 MHz	1.0
FDD 5 (1.4-10 MHz)	16-QAM	824.7 – 848 MHz	1.0
FDD 13(5-10 MHz)	QPSK	782 MHz	1.0
FDD 13 (5-10 MHz)	16-QAM	782 MHz	1.0
FDD 17 (5-10 MHz)	QPSK	710 MHz	1.0
FDD 17 (5-10 MHz)	16-QAM	710 MHz	1.0
Bluetooth	FHSS, GFSK	2402 – 2480 MHz	0.775
Bluetooth	FHSS, PI/4-DQPSK	2402 – 2480 MHz	0.775
Bluetooth	FHSS, 8-DPSK	2402 – 2480 MHz	0.775
802.11b/n20MHz	DSSS	2412 – 2462 MHz	1.0
802.11g/n20MHz	OFDM	2412 – 2462 MHz	1.0
802.11b/n40MHz	DSSS	2422 – 2452 MHz	1.0
802.11g/n40MHz	OFDM	2422 – 2452 MHz	1.0
802.11a/n20 MHz	OFDM	5180 – 5240 MHz	1.0
802.11a/n20 MHz	OFDM	5260 – 5320 MHz	1.0
802.11a/n20 MHz	OFDM	5500 – 5700 MHz	1.0
802.11a/n20 MHz	OFDM	5745 – 5825 MHz	1.0
802.11a/n40 MHz	OFDM	5190 – 5230 MHz	1.0
802.11a/n40 MHz	OFDM	5270 – 5310 MHz	1.0
802.11a/n40 MHz	OFDM	5510 – 5670 MHz	1.0
802.11a/n40 MHz	OFDM	5755 – 5795 MHz	1.0

### 1.5 Conducted Power Values

According to KDB 447498 D01 v05r02 the conducted power values of all operating modes have been measured in order to determine the worst case source-based averaged power values. The measurements were performed for all operating modes with proximity sensors deactivated. For the worst case operating modes for each radio technology affected by the proximity sensors the source-based average output power values were measured again with proximity sensor active.

The conducted power values for the various operating modes of the WiFi transmitter were measured according to KDB 248227 D01 v01r02

The conducted power values for the various operating modes of the 3G transmitter were measured according to KDB941225 D01 v02 and KDB941225 D02 v02r02

The conducted power values for the various operating modes of the 4G transmitter were measured according to KDB 941225 D05A v01

#### GSM with proximity sensor deactivated

GSM850																
Band	Mode	Channel	Frequency [MHz]	Coding	Traffic Mode	Number Timeslots	Power Level	Power TS 1 [dBm]	Power TS 2 [dBm]	Power TS 3 [dBm]	Power TS 4 [dBm]	Power TS 5 [dBm]	Power TS 6 [dBm]	Power TS 7 [dBm]	Power TS 8 [dBm]	Source-based time average Power [dBm]
850	GSM	128	824.2	FR V1	FR V1	1	PCL 5									
850	GSM	190	836.6	FR V1	FR V1	1	PCL 5									
850	GSM	251	848.0	FR V1	FR V1	1	PCL 5									
850	GPRS	128	824.2	CS1	Test Mode A	1	GAMMA 3	32.10								23.07
850	GPRS	190	836.6	CS1	Test Mode A	1	GAMMA 3	32.40								23.37
850	GPRS	251	848.0	CS1	Test Mode A	1	GAMMA 3	32.30								23.27
850	GPRS	128	824.2	CS1	Test Mode A	2	GAMMA 3	29.80	29.60							23.68
850	GPRS	190	836.6	CS1	Test Mode A	2	GAMMA 3	30.00	29.80							23.88
850	GPRS	251	848.0	CS1	Test Mode A	2	GAMMA 3	29.70	29.60							23.62
850	GPRS	128	824.2	CS1	Test Mode A	3	GAMMA 3	28.90	28.70	28.70						24.52
850	GPRS	190	836.6	CS1	Test Mode A	3	GAMMA 3	29.10	29.00	29.00						24.78
850	GPRS	251	848.0	CS1	Test Mode A	3	GAMMA 3	28.90	28.80	28.80						24.58
850	GPRS	128	824.2	CS1	Test Mode A	4	GAMMA 3	27.20	26.90	26.90	26.90					23.98
850	GPRS	190	836.6	CS1	Test Mode A	4	GAMMA 3	27.30	27.10	27.10	27.10					24.15
850	GPRS	251	848.0	CS1	Test Mode A	4	GAMMA 3	27.10	26.90	26.90	26.90					23.95
850	EGPRS	128	824.2	MCS1	Test Mode A	1	GAMMA 3	32.10								23.07
850	EGPRS	190	836.6	MCS1	Test Mode A	1	GAMMA 3	32.40								23.37
850	EGPRS	251	848.0	MCS1	Test Mode A	1	GAMMA 3	32.20								23.17
850	EGPRS	128	824.2	MCS1	Test Mode A	2	GAMMA 3	29.70	29.60							23.63
850	EGPRS	190	836.6	MCS1	Test Mode A	2	GAMMA 3	30.00	29.80							23.88
850	EGPRS	251	848.0	MCS1	Test Mode A	2	GAMMA 3	29.70	29.60							23.63
850	EGPRS	128	824.2	MCS1	Test Mode A	3	GAMMA 3	28.90	28.70	28.70						24.52
850	EGPRS	190	836.6	MCS1	Test Mode A	3	GAMMA 3	29.10	28.90	29.00						24.75
850	EGPRS	251	848.0	MCS1	Test Mode A	3	GAMMA 3	28.90	28.80	28.80						24.58
850	EGPRS	128	824.2	MCS1	Test Mode A	4	GAMMA 3	27.10	26.90	26.90	26.90					23.95
850	EGPRS	190	836.6	MCS1	Test Mode A	4	GAMMA 3	27.40	27.10	27.10	27.10					24.18
850	EGPRS	251	848.0	MCS1	Test Mode A	4	GAMMA 3	27.10	26.90	26.90	26.90					23.95
850	EGPRS	128	824.2	MC55	Test Mode A	1	GAMMA 6	26.90								17.87
850	EGPRS	190	836.6	MC55	Test Mode A	1	GAMMA 6	26.50								17.47
850	EGPRS	251	848.0	MC55	Test Mode A	1	GAMMA 6	26.60								17.57
850	EGPRS	128	824.2	MC55	Test Mode A	2	GAMMA 6	24.90	25.00							18.93
850	EGPRS	190	836.6	MC55	Test Mode A	2	GAMMA 6	24.70	24.90							18.78
850	EGPRS	251	848.0	MC55	Test Mode A	2	GAMMA 6	24.90	25.00							18.93
850	EGPRS	128	824.2	MC55	Test Mode A	3	GAMMA 6	24.10	24.00	23.90						19.75
850	EGPRS	190	836.6	MC55	Test Mode A	3	GAMMA 6	24.00	23.80	24.10						19.72
850	EGPRS	251	848.0	MC55	Test Mode A	3	GAMMA 6	24.00	23.90	23.90						19.68
850	EGPRS	128	824.2	MC55	Test Mode A	4	GAMMA 6	22.10	21.70	21.70	21.70					18.80
850	EGPRS	190	836.6	MC55	Test Mode A	4	GAMMA 6	21.30	21.90	22.00	21.60					18.71
850	EGPRS	251	848.0	MC55	Test Mode A	4	GAMMA 6	22.00	21.40	21.90	21.90					18.81

GSM1900																
Band	Mode	Channel	Frequency [MHz]	Coding	Traffic Mode	Number Timeslots	Power Level	Power TS 1 [dBm]	Power TS 2 [dBm]	Power TS 3 [dBm]	Power TS 4 [dBm]	Power TS 5 [dBm]	Power TS 6 [dBm]	Power TS 7 [dBm]	Power TS 8 [dBm]	Source-based time average Power [dBm]
1900	GSM	512	1850.2	FR V1	FR V1	1	PCL0									
1900	GSM	661	1880.0	FR V1	FR V1	1	PCL0									
1900	GSM	810	1909.8	FR V1	FR V1	1	PCL0									
1900	GPRS	512	1850.2	CS1	Test Mode A	1	GAMMA 3	28.60								19.57
1900	GPRS	661	1880.0	CS1	Test Mode A	1	GAMMA 3	28.70								19.67
1900	GPRS	810	1909.8	CS1	Test Mode A	1	GAMMA 3	28.60								19.57
1900	GPRS	512	1850.2	CS1	Test Mode A	2	GAMMA 3	26.60	26.50							20.53
1900	GPRS	661	1880.0	CS1	Test Mode A	2	GAMMA 3	26.70	26.70							20.68
1900	GPRS	810	1909.8	CS1	Test Mode A	2	GAMMA 3	26.60	26.50							20.53
1900	GPRS	512	1850.2	CS1	Test Mode A	3	GAMMA 3	25.70	25.60	25.60						21.38
1900	GPRS	661	1880.0	CS1	Test Mode A	3	GAMMA 3	25.80	25.70	25.80						21.52
1900	GPRS	810	1909.8	CS1	Test Mode A	3	GAMMA 3	25.70	25.60	25.60						21.38
1900	GPRS	512	1850.2	CS1	Test Mode A	4	GAMMA 3	23.80	23.70	23.70	23.70					20.73
1900	GPRS	661	1880.0	CS1	Test Mode A	4	GAMMA 3	23.90	23.80	23.80	23.80					20.83
1900	GPRS	810	1909.8	CS1	Test Mode A	4	GAMMA 3	23.90	23.70	23.70	23.70					20.75
1900	EGPRS	512	1850.2	MCS1	Test Mode A	1	GAMMA 3	28.60								19.57
1900	EGPRS	661	1880.0	MCS1	Test Mode A	1	GAMMA 3	28.80								19.77
1900	EGPRS	810	1909.8	MCS1	Test Mode A	1	GAMMA 3	28.60								19.57
1900	EGPRS	512	1850.2	MCS1	Test Mode A	2	GAMMA 3	26.60	26.50							20.53
1900	EGPRS	661	1880.0	MCS1	Test Mode A	2	GAMMA 3	26.70	26.60							20.63
1900	EGPRS	810	1909.8	MCS1	Test Mode A	2	GAMMA 3	26.60	26.60							20.58
1900	EGPRS	512	1850.2	MCS1	Test Mode A	3	GAMMA 3	25.70	25.60	25.60						21.38
1900	EGPRS	661	1880.0	MCS1	Test Mode A	3	GAMMA 3	25.80	25.70	25.80						21.52
1900	EGPRS	810	1909.8	MCS1	Test Mode A	3	GAMMA 3	25.70	25.60	25.70						21.42
1900	EGPRS	512	1850.2	MCS1	Test Mode A	4	GAMMA 3	23.90	23.70	23.70	23.80					20.78
1900	EGPRS	661	1880.0	MCS1	Test Mode A	4	GAMMA 3	24.00	23.90	23.90	23.90					20.93
1900	EGPRS	810	1909.8	MCS1	Test Mode A	4	GAMMA 3	23.90	23.70	23.70	23.80					20.78
1900	EGPRS	512	1850.2	MCSS	Test Mode A	1	GAMMA 5	25.10								16.07
1900	EGPRS	661	1880.0	MCSS	Test Mode A	1	GAMMA 5	25.20								16.17
1900	EGPRS	810	1909.8	MCSS	Test Mode A	1	GAMMA 5	25.80								16.77
1900	EGPRS	512	1850.2	MCSS	Test Mode A	2	GAMMA 5	23.20	23.80							17.49
1900	EGPRS	661	1880.0	MCSS	Test Mode A	2	GAMMA 5	23.50	23.50							17.48
1900	EGPRS	810	1909.8	MCSS	Test Mode A	2	GAMMA 5	23.50	23.70							17.58
1900	EGPRS	512	1850.2	MCSS	Test Mode A	3	GAMMA 5	22.00	22.90	22.00						18.07
1900	EGPRS	661	1880.0	MCSS	Test Mode A	3	GAMMA 5	22.30	22.30	22.30						18.05
1900	EGPRS	810	1909.8	MCSS	Test Mode A	3	GAMMA 5	22.50	22.40	22.70						18.29
1900	EGPRS	512	1850.2	MCSS	Test Mode A	4	GAMMA 5	20.40	20.10	20.40	20.60					17.38
1900	EGPRS	661	1880.0	MCSS	Test Mode A	4	GAMMA 5	20.20	20.70	20.40	20.50					17.45
1900	EGPRS	810	1909.8	MCSS	Test Mode A	4	GAMMA 5	20.30	20.30	20.60	19.80					17.26

GSM with proximity sensor active

GSM850																
Band	Mode	Channel	Frequency [MHz]	Coding	Traffic Mode	Number Timeslots	Power Level	Power TS 1 [dBm]	Power TS 2 [dBm]	Power TS 3 [dBm]	Power TS 4 [dBm]	Power TS 5 [dBm]	Power TS 6 [dBm]	Power TS 7 [dBm]	Power TS 8 [dBm]	Source-based time average Power [dBm]
850	GSM	128	824.2	FR V1	FR V1	1	PCL 5									
850	GSM	190	836.6	FR V1	FR V1	1	PCL 5									
850	GSM	251	848.0	FR V1	FR V1	1	PCL 5									
850	GPRS	128	824.2	CS1	Test Mode A	1	GAMMA 3	26.4								17.37
850	GPRS	190	836.6	CS1	Test Mode A	1	GAMMA 3	26.7								17.67
850	GPRS	251	848.0	CS1	Test Mode A	1	GAMMA 3	26.4								17.37
850	GPRS	128	824.2	CS1	Test Mode A	2	GAMMA 3	26.4	26.2							20.28
850	GPRS	190	836.6	CS1	Test Mode A	2	GAMMA 3	26.7	26.5							20.58
850	GPRS	251	848.0	CS1	Test Mode A	2	GAMMA 3	26.4	26.2							20.28
850	GPRS	128	824.2	CS1	Test Mode A	3	GAMMA 3	23.2	23.2	23.2						18.95
850	GPRS	190	836.6	CS1	Test Mode A	3	GAMMA 3	23.5	23.4	23.5						19.22
850	GPRS	251	848.0	CS1	Test Mode A	3	GAMMA 3	23.2	23.2	23.2						18.95
850	GPRS	128	824.2	CS1	Test Mode A	4	GAMMA 3	21.2	21.2	21.2	21.2					18.20
850	GPRS	190	836.6	CS1	Test Mode A	4	GAMMA 3	21.5	21.5	21.5	21.5					18.50
850	GPRS	251	848.0	CS1	Test Mode A	4	GAMMA 3	21.2	21.2	21.2	21.2					18.20

GSM1900																
Band	Mode	Channel	Frequency [MHz]	Coding	Traffic Mode	Number Timeslots	Power Level	Power TS 1 [dBm]	Power TS 2 [dBm]	Power TS 3 [dBm]	Power TS 4 [dBm]	Power TS 5 [dBm]	Power TS 6 [dBm]	Power TS 7 [dBm]	Power TS 8 [dBm]	Source-based time average Power [dBm]
1900	GSM	512	1850.2	FR V1	FR V1	1	PCL 0									
1900	GSM	661	1880.0	FR V1	FR V1	1	PCL 0									
1900	GSM	810	1909.8	FR V1	FR V1	1	PCL 0									
1900	GPRS	512	1850.2	CS1	Test Mode A	1	GAMMA 3	21.50								12.47
1900	GPRS	661	1880.0	CS1	Test Mode A	1	GAMMA 3	21.70								12.67
1900	GPRS	810	1909.8	CS1	Test Mode A	1	GAMMA 3	21.60								12.57
1900	GPRS	512	1850.2	CS1	Test Mode A	2	GAMMA 3	21.50	21.40							15.43
1900	GPRS	661	1880.0	CS1	Test Mode A	2	GAMMA 3	21.60	21.50							15.53
1900	GPRS	810	1909.8	CS1	Test Mode A	2	GAMMA 3	21.60	21.50							15.53
1900	GPRS	512	1850.2	CS1	Test Mode A	3	GAMMA 3	18.20	18.20	18.30						13.98
1900	GPRS	661	1880.0	CS1	Test Mode A	3	GAMMA 3	18.40	18.30	18.40						14.12
1900	GPRS	810	1909.8	CS1	Test Mode A	3	GAMMA 3	18.20	18.20	18.20						13.95
1900	GPRS	512	1850.2	CS1	Test Mode A	4	GAMMA 3	16.50	16.50	16.50	16.50					13.50
1900	GPRS	661	1880.0	CS1	Test Mode A	4	GAMMA 3	16.60	16.60	16.70	16.70					13.65
1900	GPRS	810	1909.8	CS1	Test Mode A	4	GAMMA 3	16.50	16.50	16.60	16.60					13.55

UMTS with proximity sensor deactivated

W-CDMA FDD V																		
Uplink UARFCN	Uplink Frequency [MHz]	Source-based time averaged Power [dBm]																
		RMC 12.2 kbps	RMC 64 kbps	RMC 144 kbps	RMC 384 kbps	HSDPA Subtest 1	HSDPA Subtest 2	HSDPA Subtest 3	HSDPA Subtest 4	HSUPA Subtest 1	HSUPA Subtest 2	HSUPA Subtest 3	HSUPA Subtest 4	HSUPA Subtest 5				
						Bc=2 / Bd=15	Bc=11 / Bd=15	Bc=15 / Bd=8	Bc=15 / Bd=4	Bc=10 / Bd=15 AE-DPCCH=6 AG Index = 20 No. E-TFCIs = 5 E-TFCI = 11, 67	Bc=6 / Bd=15 AE-DPCCH=8 AG Index = 12 No. E-TFCIs = 5 E-TFCI = 11, 67	Bc=15 / Bd=9 AE-DPCCH=8 AG Index = 15 No. E-TFCIs = 2 E-TFCI = 11, 92	Bc=2 / Bd=15 AE-DPCCH=5 AG Index = 17 No. E-TFCIs = 5 E-TFCI = 11, 67	Bc=14 / Bd=15 AE-DPCCH=7 AG Index = 21 No. E-TFCIs = 5 E-TFCI = 11, 67	DC-HSDPA Subtest 1	DC-HSDPA Subtest 2	DC-HSDPA Subtest 3	DC-HSDPA Subtest 4
4132	826.4	23.41	23.53	23.30	23.32	22.84	23.00	22.88	23.10	22.48	20.68	21.69	20.87	22.90	23.37	22.81	22.37	22.16
4182	836.6	23.39	23.43	23.29	23.43	23.15	23.16	23.49	23.24	22.55	20.79	21.69	21.02	22.96	23.44	22.91	22.47	22.35
4233	846.6	23.33	23.44	23.39	23.44	23.07	22.92	23.32	23.33	22.56	20.73	21.81	21.02	23.03	23.43	22.93	22.49	22.29

W-CDMA FDD II																		
Uplink UARFCN	Uplink Frequency [MHz]	Source-based time averaged Power [dBm]																
		RMC 12.2 kbps	RMC 64 kbps	RMC 144 kbps	RMC 384 kbps	HSDPA Subtest 1	HSDPA Subtest 2	HSDPA Subtest 3	HSDPA Subtest 4	HSUPA Subtest 1	HSUPA Subtest 2	HSUPA Subtest 3	HSUPA Subtest 4	HSUPA Subtest 5				
						Bc=2 / Bd=15	Bc=11 / Bd=15	Bc=15 / Bd=8	Bc=15 / Bd=4	Bc=10 / Bd=15 AE-DPCCH=6 AG Index = 20 No. E-TFCIs = 5 E-TFCI = 11, 67	Bc=6 / Bd=15 AE-DPCCH=8 AG Index = 12 No. E-TFCIs = 5 E-TFCI = 11, 67	Bc=15 / Bd=9 AE-DPCCH=8 AG Index = 15 No. E-TFCIs = 2 E-TFCI = 11, 92	Bc=2 / Bd=15 AE-DPCCH=5 AG Index = 17 No. E-TFCIs = 5 E-TFCI = 11, 67	Bc=14 / Bd=15 AE-DPCCH=7 AG Index = 21 No. E-TFCIs = 5 E-TFCI = 11, 67	DC-HSDPA Subtest 1	DC-HSDPA Subtest 2	DC-HSDPA Subtest 3	DC-HSDPA Subtest 4
9262	1852.4	22.86	22.71	22.85	22.81	22.65	22.55	22.45	22.53	22.31	20.41	21.53	20.68	22.70	22.33	22.04	22.34	22.44
9400	1880.0	23.03	22.82	22.84	22.86	22.74	22.40	22.81	22.72	21.34	20.47	21.57	20.76	22.74	22.39	22.06	22.48	22.45
9538	1907.6	22.79	22.76	22.75	22.80	22.57	22.57	22.62	22.48	22.35	20.48	21.54	20.74	22.72	22.41	22.08	22.38	22.39

W-CDMA FDD IV																		
Uplink UARFCN	Uplink Frequency [MHz]	Source-based time averaged Power [dBm]																
		RMC 12.2 kbps	RMC 64 kbps	RMC 144 kbps	RMC 384 kbps	HSDPA Subtest 1	HSDPA Subtest 2	HSDPA Subtest 3	HSDPA Subtest 4	HSUPA Subtest 1	HSUPA Subtest 2	HSUPA Subtest 3	HSUPA Subtest 4	HSUPA Subtest 5				
						Bc=2 / Bd=15	Bc=11 / Bd=15	Bc=15 / Bd=8	Bc=15 / Bd=4	Bc=10 / Bd=15 AE-DPCCH=6 AG Index = 20 No. E-TFCIs = 5 E-TFCI = 11, 67	Bc=6 / Bd=15 AE-DPCCH=8 AG Index = 12 No. E-TFCIs = 5 E-TFCI = 11, 67	Bc=15 / Bd=9 AE-DPCCH=8 AG Index = 15 No. E-TFCIs = 2 E-TFCI = 11, 92	Bc=2 / Bd=15 AE-DPCCH=5 AG Index = 17 No. E-TFCIs = 5 E-TFCI = 11, 67	Bc=14 / Bd=15 AE-DPCCH=7 AG Index = 21 No. E-TFCIs = 5 E-TFCI = 11, 67	DC-HSDPA Subtest 1	DC-HSDPA Subtest 2	DC-HSDPA Subtest 3	DC-HSDPA Subtest 4
1312	1712.4	23.50	23.48	23.50	23.48	22.85	23.01	23.23	23.11	22.59	20.89	21.72	20.99	22.87	23.45	22.84	22.65	22.23
1413	1732.6	23.53	23.48	23.42	23.42	23.18	22.86	23.17	23.19	22.69	20.46	21.78	21.00	22.89	23.49	22.88	22.69	22.19
1513	1752.6	23.46	23.52	23.46	23.44	22.96	23.04	22.79	23.24	22.53	20.76	21.77	21.12	22.91	23.43	22.56	22.67	22.24

UMTS with proximity sensor active

W-CDMA FDD V																		
Uplink UARFCN	Uplink Frequency [MHz]	Source-based time averaged Power [dBm]																
		RMC 12.2 kbps	RMC 64 kbps	RMC 144 kbps	RMC 384 kbps	HSDPA Subtest 1	HSDPA Subtest 2	HSDPA Subtest 3	HSDPA Subtest 4	HSUPA Subtest 1	HSUPA Subtest 2	HSUPA Subtest 3	HSUPA Subtest 4	HSUPA Subtest 5				
						Bc=2 / Bd=15	Bc=11 / Bd=15	Bc=15 / Bd=8	Bc=15 / Bd=4	Bc=10 / Bd=15 AE-DPCCH=6 AG Index = 20 No. E-TFCIs = 5 E-TFCI = 11, 67	Bc=6 / Bd=15 AE-DPCCH=8 AG Index = 12 No. E-TFCIs = 5 E-TFCI = 11, 67	Bc=15 / Bd=9 AE-DPCCH=8 AG Index = 15 No. E-TFCIs = 2 E-TFCI = 11, 92	Bc=2 / Bd=15 AE-DPCCH=5 AG Index = 17 No. E-TFCIs = 5 E-TFCI = 11, 67	Bc=14 / Bd=15 AE-DPCCH=7 AG Index = 21 No. E-TFCIs = 5 E-TFCI = 11, 67	DC-HSDPA Subtest 1	DC-HSDPA Subtest 2	DC-HSDPA Subtest 3	DC-HSDPA Subtest 4
4132	826.4	17.72																
4182	836.6	17.69																
4233	846.6	17.70																

W-CDMA FDD II																		
Uplink UARFCN	Uplink Frequency [MHz]	Source-based time averaged Power [dBm]																
		RMC 12.2 kbps	RMC 64 kbps	RMC 144 kbps	RMC 384 kbps	HSDPA Subtest 1	HSDPA Subtest 2	HSDPA Subtest 3	HSDPA Subtest 4	HSUPA Subtest 1	HSUPA Subtest 2	HSUPA Subtest 3	HSUPA Subtest 4	HSUPA Subtest 5				
						Bc=2 / Bd=15	Bc=11 / Bd=15	Bc=15 / Bd=8	Bc=15 / Bd=4	Bc=10 / Bd=15 AE-DPCCH=6 AG Index = 20 No. E-TFCIs = 5 E-TFCI = 11, 67	Bc=6 / Bd=15 AE-DPCCH=8 AG Index = 12 No. E-TFCIs = 5 E-TFCI = 11, 67	Bc=15 / Bd=9 AE-DPCCH=8 AG Index = 15 No. E-TFCIs = 2 E-TFCI = 11, 92	Bc=2 / Bd=15 AE-DPCCH=5 AG Index = 17 No. E-TFCIs = 5 E-TFCI = 11, 67	Bc=14 / Bd=15 AE-DPCCH=7 AG Index = 21 No. E-TFCIs = 5 E-TFCI = 11, 67	DC-HSDPA Subtest 1	DC-HSDPA Subtest 2	DC-HSDPA Subtest 3	DC-HSDPA Subtest 4
9262	1852.4	15.72																
9400	1880.0	15.77																
9538	1907.6	16.69																

W-CDMA FDD IV																		
Uplink UARFCN	Uplink Frequency [MHz]	Source-based time averaged Power [dBm]																
		RMC 12.2 kbps	RMC 64 kbps	RMC 144 kbps	RMC 384 kbps	HSDPA Subtest 1	HSDPA Subtest 2	HSDPA Subtest 3	HSDPA Subtest 4	HSUPA Subtest 1	HSUPA Subtest 2	HSUPA Subtest 3	HSUPA Subtest 4	HSUPA Subtest 5				
						Bc=2 / Bd=15	Bc=11 / Bd=15	Bc=15 / Bd=8	Bc=15 / Bd=4	Bc=10 / Bd=15 AE-DPCCH=6 AG Index = 20 No. E-TFCIs = 5 E-TFCI = 11, 67	Bc=6 / Bd=15 AE-DPCCH=8 AG Index = 12 No. E-TFCIs = 5 E-TFCI = 11, 67	Bc=15 / Bd=9 AE-DPCCH=8 AG Index = 15 No. E-TFCIs = 2 E-TFCI = 11, 92	Bc=2 / Bd=15 AE-DPCCH=5 AG Index = 17 No. E-TFCIs = 5 E-TFCI = 11, 67	Bc=14 / Bd=15 AE-DPCCH=7 AG Index = 21 No. E-TFCIs = 5 E-TFCI = 11, 67	DC-HSDPA Subtest 1	DC-HSDPA Subtest 2	DC-HSDPA Subtest 3	DC-HSDPA Subtest 4
1312	1712.4	16.15																
1413	1732.6	16.24																
1513	1752.6	16.00																

According to KDB 941225 D01 v02 SAR measurements for packet data modes (HSDPA/HSUPA) are not necessary because the conducted power values are not more than 1/4 dB higher than the power values for RMC.

LTE with proximity sensor deactivated

LTE Band 2 (PCS) Conducted Powers - 1.4 MHz Bandwidth								
Frequency [MHz]	Channel	Bandwidth	Modulation	RB Size	RB Offset	Conducted Power	MPR Allowed per 3GPP [dBm]	MPR [dB]
1850.7	18607	1.4	QPSK	1	0	22.91	0	0
1850.7	18607	1.4	QPSK	1	2	22.86	0	0
1850.7	18607	1.4	QPSK	1	5	22.87	0	0
1850.7	18607	1.4	QPSK	3	0	22.8	0	0
1850.7	18607	1.4	QPSK	3	2	22.78	0	0
1850.7	18607	1.4	QPSK	3	3	22.83	0	0
1850.7	18607	1.4	QPSK	6	0	21.66	0-1	1
1850.7	18607	1.4	16-QAM	1	0	21.49	0-1	1
1850.7	18607	1.4	16-QAM	1	2	21.45	0-1	1
1850.7	18607	1.4	16-QAM	1	5	21.5	0-1	1
1850.7	18607	1.4	16-QAM	3	0	21.88	0-1	1
1850.7	18607	1.4	16-QAM	3	2	21.84	0-1	1
1850.7	18607	1.4	16-QAM	3	3	21.87	0-1	1
1850.7	18607	1.4	16-QAM	6	0	20.93	0-2	2
1880	18900	1.4	QPSK	1	0	22.93	0	0
1880	18900	1.4	QPSK	1	2	22.95	0	0
1880	18900	1.4	QPSK	1	5	22.98	0	0
1880	18900	1.4	QPSK	3	0	22.85	0	0
1880	18900	1.4	QPSK	3	2	22.92	0	0
1880	18900	1.4	QPSK	3	3	22.9	0	0
1880	18900	1.4	QPSK	6	0	21.87	0-1	1
1880	18900	1.4	16-QAM	1	0	21.82	0-1	1
1880	18900	1.4	16-QAM	1	2	21.86	0-1	1
1880	18900	1.4	16-QAM	1	5	21.88	0-1	1
1880	18900	1.4	16-QAM	3	0	22.18	0-1	1
1880	18900	1.4	16-QAM	3	2	22.23	0-1	1
1880	18900	1.4	16-QAM	3	3	22.2	0-1	1
1880	18900	1.4	16-QAM	6	0	21.22	0-2	2
1909.3	19193	1.4	QPSK	1	0	22.65	0	0
1909.3	19193	1.4	QPSK	1	2	22.64	0	0
1909.3	19193	1.4	QPSK	1	5	22.73	0	0
1909.3	19193	1.4	QPSK	3	0	22.62	0	0
1909.3	19193	1.4	QPSK	3	2	22.63	0	0
1909.3	19193	1.4	QPSK	3	3	22.6	0	0
1909.3	19193	1.4	QPSK	6	0	21.71	0-1	1
1909.3	19193	1.4	16-QAM	1	0	22.2	0-1	1
1909.3	19193	1.4	16-QAM	1	2	22.24	0-1	1
1909.3	19193	1.4	16-QAM	1	5	22.23	0-1	1
1909.3	19193	1.4	16-QAM	3	0	22.05	0-1	1
1909.3	19193	1.4	16-QAM	3	2	22.04	0-1	1
1909.3	19193	1.4	16-QAM	3	3	22.03	0-1	1
1909.3	19193	1.4	16-QAM	6	0	20.82	0-2	2

LTE Band 2 (PCS) Conducted Powers -3 MHz Bandwidth								
Frequency [MHz]	Channel	Bandwidth	Modulation	RB Size	RB Offset	Conducted Power	MPR Allowed	MPR [dB]
1851.5	18615	3	QPSK	1	0	22.88	0	0
1851.5	18615	3	QPSK	1	7	22.75	0	0
1851.5	18615	3	QPSK	1	14	22.79	0	0
1851.5	18615	3	QPSK	8	0	21.78	0-1	1
1851.5	18615	3	QPSK	8	4	21.83	0-1	1
1851.5	18615	3	QPSK	8	7	21.79	0-1	1
1851.5	18615	3	QPSK	15	0	21.84	0-1	1
1851.5	18615	3	16-QAM	1	0	21.88	0-1	1
1851.5	18615	3	16-QAM	1	7	21.91	0-1	1
1851.5	18615	3	16-QAM	1	14	21.9	0-1	1
1851.5	18615	3	16-QAM	8	0	20.98	0-2	2
1851.5	18615	3	16-QAM	8	4	21.03	0-2	2
1851.5	18615	3	16-QAM	8	7	21.06	0-2	2
1851.5	18615	3	16-QAM	15	0	21.03	0-2	2
1880	18900	3	QPSK	1	0	22.93	0	0
1880	18900	3	QPSK	1	7	22.9	0	0
1880	18900	3	QPSK	1	14	22.98	0	0
1880	18900	3	QPSK	8	0	22.03	0-1	1
1880	18900	3	QPSK	8	4	22.07	0-1	1
1880	18900	3	QPSK	8	7	22.1	0-1	1
1880	18900	3	QPSK	15	0	22.07	0-1	1
1880	18900	3	16-QAM	1	0	22.12	0-1	1
1880	18900	3	16-QAM	1	7	22.1	0-1	1
1880	18900	3	16-QAM	1	14	22.14	0-1	1
1880	18900	3	16-QAM	8	0	21.22	0-2	2
1880	18900	3	16-QAM	8	4	21.28	0-2	2
1880	18900	3	16-QAM	8	7	21.32	0-2	2
1880	18900	3	16-QAM	15	0	21.28	0-2	2
1908.5	19185	3	QPSK	1	0	22.79	0	0
1908.5	19185	3	QPSK	1	7	22.74	0	0
1908.5	19185	3	QPSK	1	14	22.73	0	0
1908.5	19185	3	QPSK	8	0	21.82	0-1	1
1908.5	19185	3	QPSK	8	4	21.81	0-1	1
1908.5	19185	3	QPSK	8	7	21.81	0-1	1
1908.5	19185	3	QPSK	15	0	21.82	0-1	1
1908.5	19185	3	16-QAM	1	0	22.28	0-1	1
1908.5	19185	3	16-QAM	1	7	22.25	0-1	1
1908.5	19185	3	16-QAM	1	14	22.3	0-1	1
1908.5	19185	3	16-QAM	8	0	21.07	0-2	2
1908.5	19185	3	16-QAM	8	4	21.1	0-2	2
1908.5	19185	3	16-QAM	8	7	21.08	0-2	2
1908.5	19185	3	16-QAM	15	0	21.02	0-2	2



LTE Band 2 (PCS) Conducted Powers -5 MHz Bandwidth								
Frequency [MHz]	Channel	Bandwidth	Modulation	RB Size	RB Offset	Conducted Power	MPR Allowed	MPR [dB]
1852.5	18625	5	QPSK	1	0	22.27	0	0
1852.5	18625	5	QPSK	1	12	22.59	0	0
1852.5	18625	5	QPSK	1	24	22.27	0	0
1852.5	18625	5	QPSK	12	0	21.54	0-1	1
1852.5	18625	5	QPSK	12	6	21.69	0-1	1
1852.5	18625	5	QPSK	12	13	21.63	0-1	1
1852.5	18625	5	QPSK	25	0	21.66	0-1	1
1852.5	18625	5	16-QAM	1	0	21.52	0-1	1
1852.5	18625	5	16-QAM	1	12	21.91	0-1	1
1852.5	18625	5	16-QAM	1	24	21.6	0-1	1
1852.5	18625	5	16-QAM	12	0	20.8	0-2	2
1852.5	18625	5	16-QAM	12	6	20.87	0-2	2
1852.5	18625	5	16-QAM	12	13	20.86	0-2	2
1852.5	18625	5	16-QAM	25	0	20.87	0-2	2
1880	18900	5	QPSK	1	0	23.05	0	0
1880	18900	5	QPSK	1	12	23.3	0	0
1880	18900	5	QPSK	1	24	22.9	0	0
1880	18900	5	QPSK	12	0	21.9	0-1	1
1880	18900	5	QPSK	12	6	21.85	0-1	1
1880	18900	5	QPSK	12	13	21.78	0-1	1
1880	18900	5	QPSK	25	0	21.86	0-1	1
1880	18900	5	16-QAM	1	0	21.7	0-1	1
1880	18900	5	16-QAM	1	12	21.66	0-1	1
1880	18900	5	16-QAM	1	24	21.58	0-1	1
1880	18900	5	16-QAM	12	0	20.94	0-2	2
1880	18900	5	16-QAM	12	6	20.89	0-2	2
1880	18900	5	16-QAM	12	13	20.87	0-2	2
1880	18900	5	16-QAM	25	0	21.01	0-2	2
1907.5	19175	5	QPSK	1	0	22.35	0	0
1907.5	19175	5	QPSK	1	12	22.84	0	0
1907.5	19175	5	QPSK	1	24	22.42	0	0
1907.5	19175	5	QPSK	12	0	21.79	0-1	1
1907.5	19175	5	QPSK	12	6	21.93	0-1	1
1907.5	19175	5	QPSK	12	13	21.82	0-1	1
1907.5	19175	5	QPSK	25	0	21.81	0-1	1
1907.5	19175	5	16-QAM	1	0	21.66	0-1	1
1907.5	19175	5	16-QAM	1	12	22.21	0-1	1
1907.5	19175	5	16-QAM	1	24	21.7	0-1	1
1907.5	19175	5	16-QAM	12	0	21.03	0-2	2
1907.5	19175	5	16-QAM	12	6	21.15	0-2	2
1907.5	19175	5	16-QAM	12	13	21.03	0-2	2
1907.5	19175	5	16-QAM	25	0	21	0-2	2

LTE Band 2 (PCS) Conducted Powers -10 MHz Bandwidth								
Frequency [MHz]	Channel	Bandwidth	Modulation	RB Size	RB Offset	Conducted Power	MPR Allowed	MPR [dB]
1855	18650	10	QPSK	1	0	22.38	0	0
1855	18650	10	QPSK	1	25	22.58	0	0
1855	18650	10	QPSK	1	49	22.66	0	0
1855	18650	10	QPSK	25	0	21.65	0-1	1
1855	18650	10	QPSK	25	12	21.69	0-1	1
1855	18650	10	QPSK	25	25	21.78	0-1	1
1855	18650	10	QPSK	50	0	21.71	0-1	1
1855	18650	10	16QAM	1	0	21.61	0-1	1
1855	18650	10	16QAM	1	25	21.79	0-1	1
1855	18650	10	16QAM	1	49	21.81	0-1	1
1855	18650	10	16QAM	25	0	20.9	0-2	2
1855	18650	10	16QAM	25	12	20.95	0-2	2
1855	18650	10	16QAM	25	25	21.03	0-2	2
1855	18650	10	16QAM	50	0	20.88	0-2	2
1880	18900	10	QPSK	1	0	22.64	0	0
1880	18900	10	QPSK	1	25	22.91	0	0
1880	18900	10	QPSK	1	49	22.85	0	0
1880	18900	10	QPSK	25	0	21.89	0-1	1
1880	18900	10	QPSK	25	12	22.02	0-1	1
1880	18900	10	QPSK	25	25	22.08	0-1	1
1880	18900	10	QPSK	50	0	21.99	0-1	1
1880	18900	10	16QAM	1	0	21.84	0-1	1
1880	18900	10	16QAM	1	25	22.1	0-1	1
1880	18900	10	16QAM	1	49	22.04	0-1	1
1880	18900	10	16QAM	25	0	21.16	0-2	2
1880	18900	10	16QAM	25	12	21.24	0-2	2
1880	18900	10	16QAM	25	25	21.33	0-2	2
1880	18900	10	16QAM	50	0	21.16	0-2	2
1905	19150	10	QPSK	1	0	22.66	0	0
1905	19150	10	QPSK	1	25	22.74	0	0
1905	19150	10	QPSK	1	49	22.63	0	0
1905	19150	10	QPSK	25	0	21.87	0-1	1
1905	19150	10	QPSK	25	12	21.87	0-1	1
1905	19150	10	QPSK	25	25	21.88	0-1	1
1905	19150	10	QPSK	50	0	21.91	0-1	1
1905	19150	10	16QAM	1	0	21.92	0-1	1
1905	19150	10	16QAM	1	25	21.97	0-1	1
1905	19150	10	16QAM	1	49	21.82	0-1	1
1905	19150	10	16QAM	25	0	21.13	0-2	2
1905	19150	10	16QAM	25	12	21.11	0-2	2
1905	19150	10	16QAM	25	25	21.1	0-2	2
1905	19150	10	16QAM	50	0	21.02	0-2	2

LTE Band 2 (PCS) Conducted Powers -15 MHz Bandwidth								
Frequency [MHz]	Channel	Bandwidth	Modulation	RB Size	RB Offset	Conducted Power	MPR Allowed	MPR [dB]
1857.5	18675	15	QPSK	1	0	22.38	0	0
1857.5	18675	15	QPSK	1	36	22.58	0	0
1857.5	18675	15	QPSK	1	74	22.51	0	0
1857.5	18675	15	QPSK	36	0	21.67	0-1	1
1857.5	18675	15	QPSK	36	18	21.77	0-1	1
1857.5	18675	15	QPSK	36	37	21.77	0-1	1
1857.5	18675	15	QPSK	75	0	21.72	0-1	1
1857.5	18675	15	16QAM	1	0	21.36	0-1	1
1857.5	18675	15	16QAM	1	36	21.54	0-1	1
1857.5	18675	15	16QAM	1	74	21.49	0-1	1
1857.5	18675	15	16QAM	36	0	21.06	0-2	2
1857.5	18675	15	16QAM	36	18	21.2	0-2	2
1857.5	18675	15	16QAM	36	37	21.2	0-2	2
1857.5	18675	15	16QAM	75	0	21.18	0-2	2
1880	18900	15	QPSK	1	0	22.84	0	0
1880	18900	15	QPSK	1	36	22.93	0	0
1880	18900	15	QPSK	1	74	23.09	0	0
1880	18900	15	QPSK	36	0	21.98	0-1	1
1880	18900	15	QPSK	36	18	22	0-1	1
1880	18900	15	QPSK	36	37	22.16	0-1	1
1880	18900	15	QPSK	75	0	22.03	0-1	1
1880	18900	15	16QAM	1	0	21.99	0-1	1
1880	18900	15	16QAM	1	36	22.12	0-1	1
1880	18900	15	16QAM	1	74	22.27	0-1	1
1880	18900	15	16QAM	36	0	21.17	0-2	2
1880	18900	15	16QAM	36	18	21.22	0-2	2
1880	18900	15	16QAM	36	37	21.35	0-2	2
1880	18900	15	16QAM	75	0	21.21	0-2	2
1902.5	19125	15	QPSK	1	0	23.01	0	0
1902.5	19125	15	QPSK	1	36	22.96	0	0
1902.5	19125	15	QPSK	1	74	22.77	0	0
1902.5	19125	15	QPSK	36	0	22.03	0-1	1
1902.5	19125	15	QPSK	36	18	21.96	0-1	1
1902.5	19125	15	QPSK	36	37	21.9	0-1	1
1902.5	19125	15	QPSK	75	0	21.91	0-1	1
1902.5	19125	15	16QAM	1	0	22.5	0-1	1
1902.5	19125	15	16QAM	1	36	22.43	0-1	1
1902.5	19125	15	16QAM	1	74	22.2	0-1	1
1902.5	19125	15	16QAM	36	0	21.26	0-2	2
1902.5	19125	15	16QAM	36	18	21.18	0-2	2
1902.5	19125	15	16QAM	36	37	21.1	0-2	2
1902.5	19125	15	16QAM	75	0	21.13	0-2	2

LTE Band 2 (PCS) Conducted Powers -20 MHz Bandwidth								
Frequency [MHz]	Channel	Bandwidth	Modulation	RB Size	RB Offset	Conducted Power	MPR Allowed	MPR [dB]
1860	18700	20	QPSK	1	0	22.22	0	0
1860	18700	20	QPSK	1	50	22.59	0	0
1860	18700	20	QPSK	1	99	22.08	0	0
1860	18700	20	QPSK	50	0	21.83	0-1	1
1860	18700	20	QPSK	50	25	21.86	0-1	1
1860	18700	20	QPSK	50	50	21.74	0-1	1
1860	18700	20	QPSK	100	0	21.87	0-1	1
1860	18700	20	16QAM	1	0	21.84	0-1	1
1860	18700	20	16QAM	1	50	22.19	0-1	1
1860	18700	20	16QAM	1	99	21.7	0-1	1
1860	18700	20	16QAM	50	0	20.99	0-2	2
1860	18700	20	16QAM	50	25	21.04	0-2	2
1860	18700	20	16QAM	50	50	20.93	0-2	2
1860	18700	20	16QAM	100	0	21.03	0-2	2
1880	18900	20	QPSK	1	0	22.64	0	0
1880	18900	20	QPSK	1	50	22.74	0	0
1880	18900	20	QPSK	1	99	22.98	0	0
1880	18900	20	QPSK	50	0	21.94	0-1	1
1880	18900	20	QPSK	50	25	21.91	0-1	1
1880	18900	20	QPSK	50	50	22.11	0-1	1
1880	18900	20	QPSK	100	0	22.03	0-1	1
1880	18900	20	16QAM	1	0	22.51	0-1	1
1880	18900	20	16QAM	1	50	22.59	0-1	1
1880	18900	20	16QAM	1	99	22.81	0-1	1
1880	18900	20	16QAM	50	0	21.12	0-2	2
1880	18900	20	16QAM	50	25	21.09	0-2	2
1880	18900	20	16QAM	50	50	21.34	0-2	2
1880	18900	20	16QAM	100	0	21.21	0-2	2
1900	19100	20	QPSK	1	0	22.59	0	0
1900	19100	20	QPSK	1	50	22.67	0	0
1900	19100	20	QPSK	1	99	22.48	0	0
1900	19100	20	QPSK	50	0	21.98	0-1	1
1900	19100	20	QPSK	50	25	21.87	0-1	1
1900	19100	20	QPSK	50	50	21.77	0-1	1
1900	19100	20	QPSK	100	0	21.86	0-1	1
1900	19100	20	16QAM	1	0	22.5	0-1	1
1900	19100	20	16QAM	1	50	22.55	0-1	1
1900	19100	20	16QAM	1	99	22.31	0-1	1
1900	19100	20	16QAM	50	0	21.21	0-2	2
1900	19100	20	16QAM	50	25	21.07	0-2	2
1900	19100	20	16QAM	50	50	21.02	0-2	2
1900	19100	20	16QAM	100	0	21.1	0-2	2

LTE Band 4 Conducted Powers -1.4 MHz Bandwidth								
Frequency [MHz]	Channel	Bandwidth	Modulation	RB Size	RB Offset	Conducted Power [dBm]	MPR Allowed per 3GPP [dBm]	MPR [dB]
1710.7	19957	1.4	QPSK	1	0	23.12	0	0
1710.7	19957	1.4	QPSK	1	2	23.15	0	0
1710.7	19957	1.4	QPSK	1	5	23.12	0	0
1710.7	19957	1.4	QPSK	3	0	23.17	0	0
1710.7	19957	1.4	QPSK	3	2	23.17	0	0
1710.7	19957	1.4	QPSK	3	3	23.12	0	0
1710.7	19957	1.4	QPSK	6	0	22.16	0-1	1
1710.7	19957	1.4	16-QAM	1	0	22.68	0-1	1
1710.7	19957	1.4	16-QAM	1	2	22.69	0-1	1
1710.7	19957	1.4	16-QAM	1	5	22.66	0-1	1
1710.7	19957	1.4	16-QAM	3	0	22.59	0-1	1
1710.7	19957	1.4	16-QAM	3	2	22.56	0-1	1
1710.7	19957	1.4	16-QAM	3	3	22.55	0-1	1
1710.7	19957	1.4	16-QAM	6	0	21.26	0-2	2
1732.5	20175	1.4	QPSK	1	0	23.4	0	0
1732.5	20175	1.4	QPSK	1	2	23.36	0	0
1732.5	20175	1.4	QPSK	1	5	23.2	0	0
1732.5	20175	1.4	QPSK	3	0	23.33	0	0
1732.5	20175	1.4	QPSK	3	2	23.34	0	0
1732.5	20175	1.4	QPSK	3	3	23.19	0	0
1732.5	20175	1.4	QPSK	6	0	22.24	0-1	1
1732.5	20175	1.4	16-QAM	1	0	22.34	0-1	1
1732.5	20175	1.4	16-QAM	1	2	22.27	0-1	1
1732.5	20175	1.4	16-QAM	1	5	22.26	0-1	1
1732.5	20175	1.4	16-QAM	3	0	22.66	0-1	1
1732.5	20175	1.4	16-QAM	3	2	22.56	0-1	1
1732.5	20175	1.4	16-QAM	3	3	22.54	0-1	1
1732.5	20175	1.4	16-QAM	6	0	21.6	0-2	2
1754.3	20393	1.4	QPSK	1	0	23.4	0	0
1754.3	20393	1.4	QPSK	1	2	23.44	0	0
1754.3	20393	1.4	QPSK	1	5	23.47	0	0
1754.3	20393	1.4	QPSK	3	0	23.44	0	0
1754.3	20393	1.4	QPSK	3	2	23.49	0	0
1754.3	20393	1.4	QPSK	3	3	23.45	0	0
1754.3	20393	1.4	QPSK	6	0	22.36	0-1	1
1754.3	20393	1.4	16-QAM	1	0	22.96	0-1	1
1754.3	20393	1.4	16-QAM	1	2	23.04	0-1	1
1754.3	20393	1.4	16-QAM	1	5	23.01	0-1	1
1754.3	20393	1.4	16-QAM	3	0	22.87	0-1	1
1754.3	20393	1.4	16-QAM	3	2	22.88	0-1	1
1754.3	20393	1.4	16-QAM	3	3	22.88	0-1	1
1754.3	20393	1.4	16-QAM	6	0	21.45	0-2	2

LTE Band 4 Conducted Powers -3 MHz Bandwidth								
Frequency [MHz]	Channel	Bandwidth	Modulation	RB Size	RB Offset	Conducted Power [dBm]	MPR Allowed per 3GPP [dBm]	MPR [dB]
1711.5	19965	3	QPSK	1	0	23.17	0	0
1711.5	19965	3	QPSK	1	7	23.16	0	0
1711.5	19965	3	QPSK	1	14	23.16	0	0
1711.5	19965	3	QPSK	8	0	22.2	0-1	1
1711.5	19965	3	QPSK	8	4	22.16	0-1	1
1711.5	19965	3	QPSK	8	7	22.22	0-1	1
1711.5	19965	3	QPSK	15	0	22.2	0-1	1
1711.5	19965	3	16-QAM	1	0	22.67	0-1	1
1711.5	19965	3	16-QAM	1	7	22.6	0-1	1
1711.5	19965	3	16-QAM	1	14	22.66	0-1	1
1711.5	19965	3	16-QAM	8	0	22.65	0-2	2
1711.5	19965	3	16-QAM	8	4	21.45	0-2	2
1711.5	19965	3	16-QAM	8	7	21.49	0-2	2
1711.5	19965	3	16-QAM	15	0	21.42	0-2	2
1732.5	20175	3	QPSK	1	0	23.22	0	0
1732.5	20175	3	QPSK	1	7	23.11	0	0
1732.5	20175	3	QPSK	1	14	23.23	0	0
1732.5	20175	3	QPSK	8	0	22.22	0-1	1
1732.5	20175	3	QPSK	8	4	22.15	0-1	1
1732.5	20175	3	QPSK	8	7	22.14	0-1	1
1732.5	20175	3	QPSK	15	0	22.19	0-1	1
1732.5	20175	3	16-QAM	1	0	22.32	0-1	1
1732.5	20175	3	16-QAM	1	7	22.21	0-1	1
1732.5	20175	3	16-QAM	1	14	22.31	0-1	1
1732.5	20175	3	16-QAM	8	0	21.39	0-2	2
1732.5	20175	3	16-QAM	8	4	21.32	0-2	2
1732.5	20175	3	16-QAM	8	7	21.3	0-2	2
1732.5	20175	3	16-QAM	15	0	21.36	0-2	2
1753.5	20385	3	QPSK	1	0	23.33	0	0
1753.5	20385	3	QPSK	1	7	23.33	0	0
1753.5	20385	3	QPSK	1	14	23.45	0	0
1753.5	20385	3	QPSK	8	0	22.41	0-1	1
1753.5	20385	3	QPSK	8	4	22.36	0-1	1
1753.5	20385	3	QPSK	8	7	22.39	0-1	1
1753.5	20385	3	QPSK	15	0	22.39	0-1	1
1753.5	20385	3	16-QAM	1	0	22.92	0-1	1
1753.5	20385	3	16-QAM	1	7	22.89	0-1	1
1753.5	20385	3	16-QAM	1	14	22.96	0-1	1
1753.5	20385	3	16-QAM	8	0	21.66	0-2	2
1753.5	20385	3	16-QAM	8	4	21.63	0-2	2
1753.5	20385	3	16-QAM	8	7	21.66	0-2	2
1753.5	20385	3	16-QAM	15	0	21.61	0-2	2

LTE Band 4 Conducted Powers -5 MHz Bandwidth								
Frequency [MHz]	Channel	Bandwidth	Modulation	RB Size	RB Offset	Conducted Power [dBm]	MPR Allowed per 3GPP [dBm]	MPR [dB]
1712.5	19975	5	QPSK	1	0	22.81	0	0
1712.5	19975	5	QPSK	1	12	23.18	0	0
1712.5	19975	5	QPSK	1	24	22.68	0	0
1712.5	19975	5	QPSK	12	0	22.13	0-1	1
1712.5	19975	5	QPSK	12	6	22.26	0-1	1
1712.5	19975	5	QPSK	12	13	22.15	0-1	1
1712.5	19975	5	QPSK	25	0	22.18	0-1	1
1712.5	19975	5	16-QAM	1	0	22.14	0-1	1
1712.5	19975	5	16-QAM	1	12	22.5	0-1	1
1712.5	19975	5	16-QAM	1	24	22	0-1	1
1712.5	19975	5	16-QAM	12	0	21.4	0-2	2
1712.5	19975	5	16-QAM	12	6	21.52	0-2	2
1712.5	19975	5	16-QAM	12	13	21.41	0-2	2
1712.5	19975	5	16-QAM	25	0	21.42	0-2	2
1732.5	20175	5	QPSK	1	0	22.85	0	0
1732.5	20175	5	QPSK	1	12	23.18	0	0
1732.5	20175	5	QPSK	1	24	22.94	0	0
1732.5	20175	5	QPSK	12	0	22.16	0-1	1
1732.5	20175	5	QPSK	12	6	22.24	0-1	1
1732.5	20175	5	QPSK	12	13	22.15	0-1	1
1732.5	20175	5	QPSK	25	0	22.15	0-1	1
1732.5	20175	5	16-QAM	1	0	22.6	0-1	1
1732.5	20175	5	16-QAM	1	12	22.98	0-1	1
1732.5	20175	5	16-QAM	1	24	22.69	0-1	1
1732.5	20175	5	16-QAM	12	0	21.4	0-2	2
1732.5	20175	5	16-QAM	12	6	21.48	0-2	2
1732.5	20175	5	16-QAM	12	13	21.44	0-2	2
1732.5	20175	5	16-QAM	25	0	21.27	0-2	2
1752.5	20375	5	QPSK	1	0	23.04	0	0
1752.5	20375	5	QPSK	1	12	23.46	0	0
1752.5	20375	5	QPSK	1	24	23.1	0	0
1752.5	20375	5	QPSK	12	0	22.31	0-1	1
1752.5	20375	5	QPSK	12	6	22.37	0-1	1
1752.5	20375	5	QPSK	12	13	22.31	0-1	1
1752.5	20375	5	QPSK	25	0	22.35	0-1	1
1752.5	20375	5	16-QAM	1	0	22	0-1	1
1752.5	20375	5	16-QAM	1	12	22.41	0-1	1
1752.5	20375	5	16-QAM	1	24	22.04	0-1	1
1752.5	20375	5	16-QAM	12	0	21.47	0-2	2
1752.5	20375	5	16-QAM	12	6	21.55	0-2	2
1752.5	20375	5	16-QAM	12	13	21.49	0-2	2
1752.5	20375	5	16-QAM	25	0	21.62	0-2	2

LTE Band 4 Conducted Powers -10 MHz Bandwidth								
Frequency [MHz]	Channel	Bandwidth	Modulation	RB Size	RB Offset	Conducted Power [dBm]	MPR Allowed per 3GPP [dBm]	MPR [dB]
1715	20000	10	QPSK	1	0	23.05	0	0
1715	20000	10	QPSK	1	25	23.14	0	0
1715	20000	10	QPSK	1	49	23.02	0	0
1715	20000	10	QPSK	25	0	22.32	0-1	1
1715	20000	10	QPSK	25	12	22.25	0-1	1
1715	20000	10	QPSK	25	25	22.23	0-1	1
1715	20000	10	QPSK	50	0	22.3	0-1	1
1715	20000	10	16QAM	1	0	22.26	0-1	1
1715	20000	10	16QAM	1	25	22.34	0-1	1
1715	20000	10	16QAM	1	49	22.14	0-1	1
1715	20000	10	16QAM	25	0	21.64	0-2	2
1715	20000	10	16QAM	25	12	21.57	0-2	2
1715	20000	10	16QAM	25	25	21.48	0-2	2
1715	20000	10	16QAM	50	0	21.52	0-2	2
1732.5	20175	10	QPSK	1	0	22.95	0	0
1732.5	20175	10	QPSK	1	25	23.28	0	0
1732.5	20175	10	QPSK	1	49	23.13	0	0
1732.5	20175	10	QPSK	25	0	22.33	0-1	1
1732.5	20175	10	QPSK	25	12	22.32	0-1	1
1732.5	20175	10	QPSK	25	25	22.31	0-1	1
1732.5	20175	10	QPSK	50	0	22.28	0-1	1
1732.5	20175	10	16QAM	1	0	22.1	0-1	1
1732.5	20175	10	16QAM	1	25	22.41	0-1	1
1732.5	20175	10	16QAM	1	49	22.29	0-1	1
1732.5	20175	10	16QAM	25	0	21.54	0-2	2
1732.5	20175	10	16QAM	25	12	21.57	0-2	2
1732.5	20175	10	16QAM	25	25	21.56	0-2	2
1732.5	20175	10	16QAM	50	0	21.45	0-2	2
1750	20350	10	QPSK	1	0	23.15	0	0
1750	20350	10	QPSK	1	25	23.33	0	0
1750	20350	10	QPSK	1	49	23.32	0	0
1750	20350	10	QPSK	25	0	22.39	0-1	1
1750	20350	10	QPSK	25	12	22.45	0-1	1
1750	20350	10	QPSK	25	25	22.38	0-1	1
1750	20350	10	QPSK	50	0	22.39	0-1	1
1750	20350	10	16QAM	1	0	22.38	0-1	1
1750	20350	10	16QAM	1	25	22.53	0-1	1
1750	20350	10	16QAM	1	49	22.41	0-1	1
1750	20350	10	16QAM	25	0	21.66	0-2	2
1750	20350	10	16QAM	25	12	21.67	0-2	2
1750	20350	10	16QAM	25	25	21.65	0-2	2
1750	20350	10	16QAM	50	0	21.56	0-2	2



LTE Band 4 (PCS) Conducted Powers -15 MHz Bandwidth								
Frequency [MHz]	Channel	Bandwidth	Modulation	RB Size	RB Offset	Conducted Power [dBm]	MPR Allowed per 3GPP [dBm]	MPR [dB]
1717.5	20025	15	QPSK	1	0	23.34	0	0
1717.5	20025	15	QPSK	1	36	23.41	0	0
1717.5	20025	15	QPSK	1	74	23.19	0	0
1717.5	20025	15	QPSK	36	0	22.5	0-1	1
1717.5	20025	15	QPSK	36	18	22.44	0-1	1
1717.5	20025	15	QPSK	36	37	22.37	0-1	1
1717.5	20025	15	QPSK	75	0	22.45	0-1	1
1717.5	20025	15	16QAM	1	0	22.58	0-1	1
1717.5	20025	15	16QAM	1	36	22.6	0-1	1
1717.5	20025	15	16QAM	1	74	22.45	0-1	1
1717.5	20025	15	16QAM	36	0	21.65	0-2	2
1717.5	20025	15	16QAM	36	18	21.58	0-2	2
1717.5	20025	15	16QAM	36	37	21.54	0-2	2
1717.5	20025	15	16QAM	75	0	21.59	0-2	2
1732.5	20175	15	QPSK	1	0	23.1	0	0
1732.5	20175	15	QPSK	1	36	23.25	0	0
1732.5	20175	15	QPSK	1	74	23.27	0	0
1732.5	20175	15	QPSK	36	0	22.31	0-1	1
1732.5	20175	15	QPSK	36	18	22.37	0-1	1
1732.5	20175	15	QPSK	36	37	22.31	0-1	1
1732.5	20175	15	QPSK	75	0	22.36	0-1	1
1732.5	20175	15	16QAM	1	0	22.27	0-1	1
1732.5	20175	15	16QAM	1	36	22.4	0-1	1
1732.5	20175	15	16QAM	1	74	22.43	0-1	1
1732.5	20175	15	16QAM	36	0	21.48	0-2	2
1732.5	20175	15	16QAM	36	18	21.48	0-2	2
1732.5	20175	15	16QAM	36	37	21.43	0-2	2
1732.5	20175	15	16QAM	75	0	21.5	0-2	2
1747.5	20325	15	QPSK	1	0	23.37	0	0
1747.5	20325	15	QPSK	1	36	23.49	0	0
1747.5	20325	15	QPSK	1	74	23.42	0	0
1747.5	20325	15	QPSK	36	0	22.48	0-1	1
1747.5	20325	15	QPSK	36	18	22.51	0-1	1
1747.5	20325	15	QPSK	36	37	22.46	0-1	1
1747.5	20325	15	QPSK	75	0	22.47	0-1	1
1747.5	20325	15	16QAM	1	0	22.92	0-1	1
1747.5	20325	15	16QAM	1	36	23.08	0-1	1
1747.5	20325	15	16QAM	1	74	23.01	0-1	1
1747.5	20325	15	16QAM	36	0	21.68	0-2	2
1747.5	20325	15	16QAM	36	18	21.72	0-2	2
1747.5	20325	15	16QAM	36	37	21.66	0-2	2
1747.5	20325	15	16QAM	75	0	21.65	0-2	2

LTE Band 4 Conducted Powers -20 MHz Bandwidth								
Frequency [MHz]	Channel	Bandwidth	Modulation	RB Size	RB Offset	Conducted Power [dBm]	MPR Allowed per 3GPP [dBm]	MPR [dB]
1732.5	20175	20	QPSK	1	0	23.01	0	0
1732.5	20175	20	QPSK	1	50	22.95	0	0
1732.5	20175	20	QPSK	1	99	22.92	0	0
1732.5	20175	20	QPSK	50	0	22.19	0-1	1
1732.5	20175	20	QPSK	50	25	22.23	0-1	1
1732.5	20175	20	QPSK	50	50	22.28	0-1	1
1732.5	20175	20	QPSK	100	0	22.26	0-1	1
1732.5	20175	20	16QAM	1	0	22.69	0-1	1
1732.5	20175	20	16QAM	1	50	22.84	0-1	1
1732.5	20175	20	16QAM	1	99	22.8	0-1	1
1732.5	20175	20	16QAM	50	0	21.37	0-2	2
1732.5	20175	20	16QAM	50	25	21.4	0-2	2
1732.5	20175	20	16QAM	50	50	21.44	0-2	2
1732.5	20175	20	16QAM	100	0	21.44	0-2	2

LTE Band 5 Conducted Powers -1.4 MHz Bandwidth								
Frequency [MHz]	Channel	Bandwidth	Modulation	RB Size	RB Offset	Conducted Power [dBm]	MPR Allowed per 3GPP [dBm]	MPR [dB]
824.7	20407	1.4	QPSK	1	0	23.74	0	0
824.7	20407	1.4	QPSK	1	2	23.64	0	0
824.7	20407	1.4	QPSK	1	5	23.6	0	0
824.7	20407	1.4	QPSK	3	0	23.58	0	0
824.7	20407	1.4	QPSK	3	2	23.51	0	0
824.7	20407	1.4	QPSK	3	3	23.46	0	0
824.7	20407	1.4	QPSK	6	0	22.53	0-1	1
824.7	20407	1.4	16-QAM	1	0	22.74	0-1	1
824.7	20407	1.4	16-QAM	1	2	22.68	0-1	1
824.7	20407	1.4	16-QAM	1	5	22.62	0-1	1
824.7	20407	1.4	16-QAM	3	0	22.99	0-1	1
824.7	20407	1.4	16-QAM	3	2	22.91	0-1	1
824.7	20407	1.4	16-QAM	3	3	22.85	0-1	1
824.7	20407	1.4	16-QAM	6	0	21.87	0-2	2
836.5	20525	1.4	QPSK	1	0	23.48	0	0
836.5	20525	1.4	QPSK	1	2	23.52	0	0
836.5	20525	1.4	QPSK	1	5	23.58	0	0
836.5	20525	1.4	QPSK	3	0	23.4	0	0
836.5	20525	1.4	QPSK	3	2	23.45	0	0
836.5	20525	1.4	QPSK	3	3	23.49	0	0
836.5	20525	1.4	QPSK	6	0	22.45	0-1	1
836.5	20525	1.4	16-QAM	1	0	22.49	0-1	1
836.5	20525	1.4	16-QAM	1	2	22.54	0-1	1
836.5	20525	1.4	16-QAM	1	5	22.61	0-1	1
836.5	20525	1.4	16-QAM	3	0	22.8	0-1	1
836.5	20525	1.4	16-QAM	3	2	22.85	0-1	1
836.5	20525	1.4	16-QAM	3	3	22.87	0-1	1
836.5	20525	1.4	16-QAM	6	0	21.8	0-2	2
848.3	20643	1.4	QPSK	1	0	23.35	0	0
848.3	20643	1.4	QPSK	1	2	23.55	0	0
848.3	20643	1.4	QPSK	1	5	23.6	0	0
848.3	20643	1.4	QPSK	3	0	23.44	0	0
848.3	20643	1.4	QPSK	3	2	23.54	0	0
848.3	20643	1.4	QPSK	3	3	23.5	0	0
848.3	20643	1.4	QPSK	6	0	22.47	0-1	1
848.3	20643	1.4	16-QAM	1	0	22.92	0-1	1
848.3	20643	1.4	16-QAM	1	2	23.13	0-1	1
848.3	20643	1.4	16-QAM	1	5	23.12	0-1	1
848.3	20643	1.4	16-QAM	3	0	22.86	0-1	1
848.3	20643	1.4	16-QAM	3	2	22.96	0-1	1
848.3	20643	1.4	16-QAM	3	3	22.93	0-1	1
848.3	20643	1.4	16-QAM	6	0	21.57	0-2	2

LTE Band 5 Conducted Powers -3 MHz Bandwidth								
Frequency [MHz]	Channel	Bandwidth	Modulation	RB Size	RB Offset	Conducted Power [dBm]	MPR Allowed per 3GPP [dBm]	MPR [dB]
825.5	20415	3	QPSK	1	0	23.62	0	0
825.5	20415	3	QPSK	1	7	23.52	0	0
825.5	20415	3	QPSK	1	14	23.5	0	0
825.5	20415	3	QPSK	8	0	22.5	0-1	1
825.5	20415	3	QPSK	8	4	22.52	0-1	1
825.5	20415	3	QPSK	8	7	22.6	0-1	1
825.5	20415	3	QPSK	15	0	22.62	0-1	1
825.5	20415	3	16-QAM	1	0	22.59	0-1	1
825.5	20415	3	16-QAM	1	7	22.5	0-1	1
825.5	20415	3	16-QAM	1	14	22.48	0-1	1
825.5	20415	3	16-QAM	8	0	21.68	0-2	2
825.5	20415	3	16-QAM	8	4	21.64	0-2	2
825.5	20415	3	16-QAM	8	7	21.79	0-2	2
825.5	20415	3	16-QAM	15	0	21.65	0-2	2
836.5	20525	3	QPSK	1	0	23.33	0	0
836.5	20525	3	QPSK	1	7	23.35	0	0
836.5	20525	3	QPSK	1	14	22.94	0	0
836.5	20525	3	QPSK	8	0	22.45	0-1	1
836.5	20525	3	QPSK	8	4	22.41	0-1	1
836.5	20525	3	QPSK	8	7	22.37	0-1	1
836.5	20525	3	QPSK	15	0	22.45	0-1	1
836.5	20525	3	16-QAM	1	0	22.87	0-1	1
836.5	20525	3	16-QAM	1	7	22.88	0-1	1
836.5	20525	3	16-QAM	1	14	22.5	0-1	1
836.5	20525	3	16-QAM	8	0	21.74	0-2	2
836.5	20525	3	16-QAM	8	4	21.7	0-2	2
836.5	20525	3	16-QAM	8	7	21.65	0-2	2
836.5	20525	3	16-QAM	15	0	21.67	0-2	2
847.5	20635	3	QPSK	1	0	23.41	0	0
847.5	20635	3	QPSK	1	7	23.44	0	0
847.5	20635	3	QPSK	1	14	23.59	0	0
847.5	20635	3	QPSK	8	0	22.41	0-1	1
847.5	20635	3	QPSK	8	4	22.47	0-1	1
847.5	20635	3	QPSK	8	7	22.59	0-1	1
847.5	20635	3	QPSK	15	0	22.55	0-1	1
847.5	20635	3	16-QAM	1	0	22.61	0-1	1
847.5	20635	3	16-QAM	1	7	22.63	0-1	1
847.5	20635	3	16-QAM	1	14	22.76	0-1	1
847.5	20635	3	16-QAM	8	0	21.62	0-2	2
847.5	20635	3	16-QAM	8	4	21.7	0-2	2
847.5	20635	3	16-QAM	8	7	21.79	0-2	2
847.5	20635	3	16-QAM	15	0	21.74	0-2	2

LTE Band 5 Conducted Powers -5 MHz Bandwidth								
Frequency [MHz]	Channel	Bandwidth	Modulation	RB Size	RB Offset	Conducted Power [dBm]	MPR Allowed per 3GPP [dBm]	MPR [dB]
826.5	20425	5	QPSK	1	0	23.41	0	0
826.5	20425	5	QPSK	1	12	23.68	0	0
826.5	20425	5	QPSK	1	24	23.27	0	0
826.5	20425	5	QPSK	12	0	22.65	0-1	1
826.5	20425	5	QPSK	12	6	22.62	0-1	1
826.5	20425	5	QPSK	12	13	22.54	0-1	1
826.5	20425	5	QPSK	25	0	22.57	0-1	1
826.5	20425	5	16-QAM	1	0	22.68	0-1	1
826.5	20425	5	16-QAM	1	12	22.98	0-1	1
826.5	20425	5	16-QAM	1	24	22.56	0-1	1
826.5	20425	5	16-QAM	12	0	21.74	0-2	2
826.5	20425	5	16-QAM	12	6	21.88	0-2	2
826.5	20425	5	16-QAM	12	13	21.79	0-2	2
826.5	20425	5	16-QAM	25	0	21.81	0-2	2
836.5	20525	5	QPSK	1	0	23.13	0	0
836.5	20525	5	QPSK	1	12	23.59	0	0
836.5	20525	5	QPSK	1	24	23.36	0	0
836.5	20525	5	QPSK	12	0	22.38	0-1	1
836.5	20525	5	QPSK	12	6	22.54	0-1	1
836.5	20525	5	QPSK	12	13	22.51	0-1	1
836.5	20525	5	QPSK	25	0	22.49	0-1	1
836.5	20525	5	16-QAM	1	0	22.91	0-1	1
836.5	20525	5	16-QAM	1	12	23.35	0-1	1
836.5	20525	5	16-QAM	1	24	23.14	0-1	1
836.5	20525	5	16-QAM	12	0	21.63	0-2	2
836.5	20525	5	16-QAM	12	6	21.8	0-2	2
836.5	20525	5	16-QAM	12	13	21.76	0-2	2
836.5	20525	5	16-QAM	25	0	21.66	0-2	2
846.5	20625	5	QPSK	1	0	23.05	0	0
846.5	20625	5	QPSK	1	12	23.49	0	0
846.5	20625	5	QPSK	1	24	23.46	0	0
846.5	20625	5	QPSK	12	0	22.39	0-1	1
846.5	20625	5	QPSK	12	6	22.5	0-1	1
846.5	20625	5	QPSK	12	13	22.51	0-1	1
846.5	20625	5	QPSK	25	0	22.48	0-1	1
846.5	20625	5	16-QAM	1	0	21.99	0-1	1
846.5	20625	5	16-QAM	1	12	22.5	0-1	1
846.5	20625	5	16-QAM	1	24	22.45	0-1	1
846.5	20625	5	16-QAM	12	0	21.58	0-2	2
846.5	20625	5	16-QAM	12	6	21.71	0-2	2
846.5	20625	5	16-QAM	12	13	21.73	0-2	2
846.5	20625	5	16-QAM	25	0	21.79	0-2	2

LTE Band 5 Conducted Powers -10 MHz Bandwidth								
Frequency [MHz]	Channel	Bandwidth	Modulation	RB Size	RB Offset	Conducted Power [dBm]	MPR Allowed per 3GPP [dBm]	MPR [dB]
836.5	20525	10	QPSK	1	0	23.4	0	0
836.5	20525	10	QPSK	1	25	23.5	0	0
836.5	20525	10	QPSK	1	49	23.53	0	0
836.5	20525	10	QPSK	25	0	23.58	0-1	1
836.5	20525	10	QPSK	25	12	22.56	0-1	1
836.5	20525	10	QPSK	25	25	22.68	0-1	1
836.5	20525	10	QPSK	50	0	22.62	0-1	1
836.5	20525	10	16QAM	1	0	22.58	0-1	1
836.5	20525	10	16QAM	1	25	22.74	0-1	1
836.5	20525	10	16QAM	1	49	22.73	0-1	1
836.5	20525	10	16QAM	25	0	21.85	0-2	2
836.5	20525	10	16QAM	25	12	21.84	0-2	2
836.5	20525	10	16QAM	25	25	21.93	0-2	2
836.5	20525	10	16QAM	50	0	21.72	0-2	2

LTE Band 13 Conducted Powers -5 MHz Bandwidth								
Frequency [MHz]	Channel	Bandwidth	Modulation	RB Size	RB Offset	Conducted Power [dBm]	MPR Allowed per 3GPP [dBm]	MPR [dB]
782	23230	5	QPSK	1	0	22.92	0	0
782	23230	5	QPSK	1	12	23.54	0	0
782	23230	5	QPSK	1	24	23.09	0	0
782	23230	5	QPSK	12	0	22.23	0-1	1
782	23230	5	QPSK	12	6	22.36	0-1	1
782	23230	5	QPSK	12	13	22.27	0-1	1
782	23230	5	QPSK	25	0	22.26	0-1	1
782	23230	5	16-QAM	1	0	21.86	0-1	1
782	23230	5	16-QAM	1	12	22.52	0-1	1
782	23230	5	16-QAM	1	24	22.07	0-1	1
782	23230	5	16-QAM	12	0	21.42	0-2	2
782	23230	5	16-QAM	12	6	21.57	0-2	2
782	23230	5	16-QAM	12	13	21.45	0-2	2
782	23230	5	16-QAM	25	0	21.55	0-2	2

LTE Band 13 Conducted Powers -10 MHz Bandwidth								
Frequency [MHz]	Channel	Bandwidth	Modulation	RB Size	RB Offset	Conducted Power [dBm]	MPR Allowed per 3GPP [dBm]	MPR [dB]
782	23230	10	QPSK	1	0	23.32	0	0
782	23230	10	QPSK	1	25	22.91	0	0
782	23230	10	QPSK	1	49	23.55	0	0
782	23230	10	QPSK	25	0	22.3	0-1	1
782	23230	10	QPSK	25	12	22.09	0-1	1
782	23230	10	QPSK	25	25	22.39	0-1	1
782	23230	10	QPSK	50	0	22.35	0-1	1
782	23230	10	16QAM	1	0	22.5	0-1	1
782	23230	10	16QAM	1	25	22.02	0-1	1
782	23230	10	16QAM	1	49	22.56	0-1	1
782	23230	10	16QAM	25	0	21.51	0-2	2
782	23230	10	16QAM	25	12	21.3	0-2	2
782	23230	10	16QAM	25	25	21.6	0-2	2
782	23230	10	16QAM	50	0	21.5	0-2	2

LTE Band 17 Conducted Powers -5 MHz Bandwidth								
Frequency [MHz]	Channel	Bandwidth	Modulation	RB Size	RB Offset	Conducted Power [dBm]	MPR Allowed per 3GPP [dBm]	MPR [dB]
710	23790	5	QPSK	1	0	23.04	0	0
710	23790	5	QPSK	1	12	23.55	0	0
710	23790	5	QPSK	1	24	23.54	0	0
710	23790	5	QPSK	12	0	22.33	0-1	1
710	23790	5	QPSK	12	6	22.45	0-1	1
710	23790	5	QPSK	12	13	22.53	0-1	1
710	23790	5	QPSK	25	0	22.4	0-1	1
710	23790	5	16-QAM	1	0	22	0-1	1
710	23790	5	16-QAM	1	12	22.52	0-1	1
710	23790	5	16-QAM	1	24	22.48	0-1	1
710	23790	5	16-QAM	12	0	21.54	0-2	2
710	23790	5	16-QAM	12	6	21.68	0-2	2
710	23790	5	16-QAM	12	13	21.73	0-2	2
710	23790	5	16-QAM	25	0	21.69	0-2	2

LTE Band 17 Conducted Powers -10 MHz Bandwidth								
Frequency [MHz]	Channel	Bandwidth	Modulation	RB Size	RB Offset	Conducted Power [dBm]	MPR Allowed per 3GPP [dBm]	MPR [dB]
710	23790	10	QPSK	1	0	23.02	0	0
710	23790	10	QPSK	1	25	23.19	0	0
710	23790	10	QPSK	1	49	23.68	0	0
710	23790	10	QPSK	25	0	22.14	0-1	1
710	23790	10	QPSK	25	12	22.22	0-1	1
710	23790	10	QPSK	25	25	22.59	0-1	1
710	23790	10	QPSK	50	0	22.43	0-1	1
710	23790	10	16QAM	1	0	22.3	0-1	1
710	23790	10	16QAM	1	25	22.42	0-1	1
710	23790	10	16QAM	1	49	22.94	0-1	1
710	23790	10	16QAM	25	0	21.43	0-2	2
710	23790	10	16QAM	25	12	21.5	0-2	2
710	23790	10	16QAM	25	25	21.93	0-2	2
710	23790	10	16QAM	50	0	21.55	0-2	2



LTE with proximity sensor active

LTE Band 2 (PCS) Conducted Powers -20 MHz Bandwidth								
Frequency [MHz]	Channel	Bandwidth	Modulation	RB Size	RB Offset	Conducted Power	MPR Allowed	MPR [dB]
1860	18700	20	QPSK	1	0	15.6	0	0
1860	18700	20	QPSK	1	50	15.93	0	0
1860	18700	20	QPSK	1	99	15.6	0	0
1880	18900	20	QPSK	1	0	15.86	0	0
1880	18900	20	QPSK	1	50	16.02	0	0
1880	18900	20	QPSK	1	99	16.19	0	0
1900	19100	20	QPSK	1	0	15.65	0	0
1900	19100	20	QPSK	1	50	15.79	0	0
1900	19100	20	QPSK	1	99	15.66	0	0

LTE Band 4 Conducted Powers -20 MHz Bandwidth								
Frequency [MHz]	Channel	Bandwidth	Modulation	RB Size	RB Offset	Conducted Power [dBm]	MPR Allowed per 3GPP [dBm]	MPR [dB]
1732.5	20175	20	QPSK	1	0	15.7	0	0
1732.5	20175	20	QPSK	1	50	16.09	0	0
1732.5	20175	20	QPSK	1	99	16.01	0	0

LTE Band 5 Conducted Powers -10 MHz Bandwidth								
Frequency [MHz]	Channel	Bandwidth	Modulation	RB Size	RB Offset	Conducted Power [dBm]	MPR Allowed per 3GPP [dBm]	MPR [dB]
836.5	20525	10	QPSK	1	0	18.21	0	0
836.5	20525	10	QPSK	1	25	18.35	0	0
836.5	20525	10	QPSK	1	49	18.42	0	0

LTE Band 13 Conducted Powers -10 MHz Bandwidth								
Frequency [MHz]	Channel	Bandwidth	Modulation	RB Size	RB Offset	Conducted Power [dBm]	MPR Allowed per 3GPP [dBm]	MPR [dB]
782	23230	10	QPSK	1	0	18.04	0	0
782	23230	10	QPSK	1	25	17.57	0	0
782	23230	10	QPSK	1	49	18.25	0	0

LTE Band 17 (PCS) Conducted Powers -10 MHz Bandwidth								
Frequency [MHz]	Channel	Bandwidth	Modulation	RB Size	RB Offset	Conducted Power [dBm]	MPR Allowed per 3GPP [dBm]	MPR [dB]
710	23790	10	QPSK	1	0	18.1	0	0
710	23790	10	QPSK	1	25	18.27	0	0
710	23790	10	QPSK	1	49	18.59	0	0

Bluetooth

Bluetooth							
Channel	Frequency [MHz]	Peak (Burst) RMS Power [dBm]			Source-based time averaged Power [dBm]		
		BR (GFSK)	EDR (PI/4-DQPSK)	EDR (8-DPSK)	BR (GFSK)	EDR (PI/4-DQPSK)	EDR (8-DPSK)
		DH5	2-DH5	3-DH5	DH5	2-DH5	3-DH5
0	2402	7.00	3.80	3.80	5.89	2.69	2.69
39	2441	7.80	4.40	4.40	6.69	3.29	3.29
78	2480	9.90	6.80	6.80	<b>8.79</b>	5.69	5.69

WLAN 2.4 GHz

antenna: MAIN

IEEE 802.11b						
Mode	Channel	Frequency	Source-based time average power [dBm]			
			Data Rate [Mbps]			
			1	2	5.5	11
IEEE 802.11b	1	2412	10.35	10.70	10.40	10.15
	6	2437	10.45	10.87	10.38	10.34
	11	2462	<b>10.93</b>	11.16	10.83	10.62

antenna: MAIN

IEEE 802.11g										
Mode	Channel	Frequency	Source-based time average power [dBm]							
			Data Rate [Mbps]							
			6	9	12	18	24	36	48	54
IEEE 802.11g	1	2412	9.88	9.81	9.78	9.56	9.38	9.20	8.84	8.61
	6	2437	10.12	10.06	9.87	9.79	9.69	9.30	9.12	8.86
	11	2462	<b>10.41</b>	10.41	10.23	10.01	9.92	9.57	9.41	9.22

antenna: MAIN

IEEE 802.11n / 20 MHz / 1 Stream												
Mode	Channel	Frequency	Bandwidth [MHz]	Guard Interval [ns]	Source-based time average power [dBm]							
					Data Rate [Mbps]							
					MCS0	MCS1	MCS2	MCS3	MCS4	MCS5	MCS6	MCS7
IEEE 802.11n	1	2412	20	800/400	6.5/7.2	13/14.4	19.5/21.7	26/28.9	39/43.3	52/57.8	58.5/65	65/72.2
	6	2437	20	800/400	9.10	8.75	8.57	8.21	8.18	7.26	7.08	6.28
	11	2462	20	800/400	<b>10.27</b>	9.97	9.88	9.79	9.37	9.10	8.85	8.82

IEEE 802.11n / 20 MHz / 2 Streams												
Mode	Channel	Frequency	Bandwidth [MHz]	Guard Interval [ns]	Source-based time average power [dBm]							
					Data Rate [Mbps] antenna MAIN / AUX							
					MCS8	MCS9	MCS10	MCS11	MCS12	MCS13	MCS14	MCS15
IEEE 802.11n	1	2412	20	800/400	9.25 / 9.68	8.25 / 9.34	7.78 / 9.16	7.39 / 8.7	6.66 / 8.32	6.36 / 7.89	6.1 / 7.85	5.39 / 7.5
	6	2437	20	800/400	9.13 / 9.74	8.44 / 9.28	8.03 / 9.03	7.72 / 8.8	7.15 / 8.29	6.55 / 7.8	6.38 / 7.8	5.72 / 7.39
	11	2462	20	800/400	10.05 / 9.61	9.87 / 9.33	9.43 / 9.08	9.14 / 8.64	8.7 / 8.32	8.21 / 7.95	8.19 / 7.71	7.94 / 7.84

IEEE 802.11n / 40 MHz / Long Guard Interval / 2 Streams												
Mode	Channel	Frequency	Bandwidth [MHz]	Guard Interval [ns]	Source-based time average power [dBm]							
					Data Rate [Mbps] antenna MAIN / AUX							
					MCS8	MCS9	MCS10	MCS11	MCS12	MCS13	MCS14	MCS15
IEEE 802.11n	1	2422	40	800	8.9 / 8.76	8.21 / 8.28	7.71 / 7.75	7.38 / 7.28	6.67 / 6.77	6.33 / 6.32	6.15 / 6.12	5.41 / 5.54
	6	2437	40	800	9.09 / 8.86	8.44 / 8.23	8.07 / 7.73	7.79 / 7.47	6.96 / 6.76	6.65 / 6.38	6.45 / 6.17	5.64 / 5.34
	9	2452	40	800	9.27 / 8.87	8.61 / 8.19	8.24 / 7.8	7.91 / 7.29	7.11 / 6.75	6.71 / 6.19	6.5 / 6.19	5.8 / 5.8

According to KDB 248227 v01r02 SAR measurements for 802.11g are not necessary because the conducted power values are not more than ¼ dB higher than the power values for 802.11b.

According to KDB 248227 v01r02 SAR measurements for 802.11n are not necessary because the conducted power values are not more than ¼ dB higher than the power values for 802.11b.

Test Report No.: G0M-1407-3981-TFC093SR-V01

According to KDB 248227 v01r02 SAR measurements are performed for 802.11b and the lowest data rate of 1 Mbps.

WLAN 5 GHz

antenna: MAIN

IEEE 802.11a											
Mode	Band	Channel	Frequency	Source-based time average power [dBm]							
				Data Rate [Mbps]							
				6	9	12	18	24	36	48	54
IEEE 802.11a	U-NII-1	36	5180	11.60	11.66	11.33	11.30	11.14	10.76	10.63	10.47
		40	5200	11.65	11.57	11.47	11.18	11.08	10.82	10.62	10.35
		44	5220	11.63	11.59	11.47	11.19	11.05	10.79	10.47	10.33
		48	5240	<b>11.69</b>	11.61	11.40	11.29	11.14	10.75	10.56	10.41
	U-NII-2	52	5260	11.64	11.54	11.47	11.34	11.16	10.77	10.53	10.34
		56	5280	<b>11.67</b>	11.44	11.49	11.22	11.07	10.82	10.50	10.37
		60	5300	11.60	11.40	11.31	11.31	11.02	10.76	10.43	10.31
		64	5320	11.63	11.44	11.38	11.27	10.99	10.65	10.44	10.36
	U-NII-2e	100	5500	<b>10.80</b>	10.74	10.57	10.39	10.24	10.00	9.62	9.53
		104	5520	10.70	10.63	10.56	10.46	10.31	10.13	9.51	9.47
		108	5540	10.52	10.47	10.38	10.26	10.12	9.82	9.53	9.40
		112	5560	10.51	10.41	10.33	10.18	9.91	9.58	9.42	9.19
		116	5580	10.40	10.26	10.14	10.00	9.86	9.50	9.25	9.16
		120	5600	N/A	N/A	N/A	N/A	N/A	N/A	N/A	N/A
		124	5620	N/A	N/A	N/A	N/A	N/A	N/A	N/A	N/A
		128	5640	N/A	N/A	N/A	N/A	N/A	N/A	N/A	N/A
	U-NII-3	132	5660	10.00	9.92	9.73	9.56	9.40	9.10	8.71	8.71
		136	5680	9.90	9.75	9.66	9.50	9.20	9.04	8.75	8.49
		140	5700	9.78	9.73	9.64	9.36	9.23	8.85	8.63	8.50
		149	5745	9.73	9.67	9.59	9.33	9.18	8.85	8.55	8.44
		153	5765	9.73	9.63	9.50	9.24	9.15	8.93	8.54	8.56
		157	5785	9.73	9.57	9.57	9.24	9.27	8.84	8.55	8.50
		161	5805	<b>9.83</b>	9.60	9.52	9.37	9.23	8.90	8.60	8.50
		165	5825	9.80	9.72	9.55	9.46	9.26	8.97	8.60	8.48

antenna: MAIN

IEEE 802.11n / 20 MHz / 1 Stream													
Mode	Band	Channel	Frequency	Bandwidth [MHz]	Guard Interval [ns]	Source-based time average power [dBm]							
						Data Rate [Mbps]							
						MCS0	MCS1	MCS2	MCS3	MCS4	MCS5	MCS6	MCS7
IEEE 802.11n	U-NII-1	36	5180	20	800/400	<b>6.5/7.2</b>	<b>13/14.4</b>	<b>19.5/21.7</b>	<b>26/28.9</b>	<b>39/43.3</b>	<b>52/57.8</b>	<b>58.5/65</b>	<b>65/72.2</b>
		40	5200			8.03	7.76	7.60	7.44	7.19	6.92	6.83	6.74
		44	5220			8.20	7.95	7.76	7.60	7.20	7.02	6.90	6.69
		48	5240			8.08	7.92	7.73	7.55	7.28	6.93	6.83	6.69
	U-NII-2	52	5260	20	800/400	8.00	7.73	7.66	7.45	7.23	6.99	6.76	6.70
		56	5280			8.19	8.00	7.73	7.43	7.29	6.89	6.80	6.81
		60	5300			7.95	7.79	7.75	7.47	7.18	6.80	6.87	6.72
		64	5320			8.12	7.84	7.68	7.51	7.13	6.93	6.77	6.67
	U-NII-2e	100	5500	20	800/400	8.17	7.86	7.67	7.39	7.17	6.81	6.68	6.57
		104	5520			7.93	7.40	7.22	7.02	6.84	6.49	6.40	6.31
		108	5540			7.40	7.22	7.07	6.88	6.63	6.42	6.31	6.23
		112	5560			7.25	7.07	6.78	6.75	6.50	6.13	6.02	5.93
		116	5580			7.26	6.79	6.76	6.64	6.26	5.98	5.91	5.77
		120	5600			7.15	6.92	6.73	6.47	6.20	5.95	5.73	5.62
		124	5620			N/A	N/A	N/A	N/A	N/A	N/A	N/A	N/A
		128	5640			N/A	N/A	N/A	N/A	N/A	N/A	N/A	N/A
	U-NII-3	132	5660	20	800/400	6.62	6.47	6.21	6.05	5.89	5.40	5.22	5.21
		136	5680			6.47	6.21	6.15	5.91	5.63	5.41	5.33	5.16
		140	5700			6.41	6.30	6.13	5.80	5.57	5.35	5.11	5.10
		149	5745			6.65	6.48	6.20	6.14	5.75	5.53	5.40	5.32
		153	5765			6.66	6.53	6.25	6.15	5.74	5.40	5.37	5.31
		157	5785			6.67	6.50	6.25	6.06	5.73	5.53	5.37	5.24
		161	5805			6.72	6.53	6.42	6.08	5.88	5.55	5.42	5.28
		165	5825			6.75	6.45	6.27	6.15	5.76	5.52	5.53	5.15

IEEE 802.11n / 20 MHz / 2 Streams							
Mode	Band	Channel	Frequency	Bandwidth [MHz]	Guard Interval [ns]	Source-based time average power [dBm]	
						Data Rate [Mbps]	antenna: MAIN / antenna: AUX
IEEE 802.11n	U-NII-1	36	5180	20	800/400	MCS8	
		40	5200			13/14.4	
		44	5220			7.59 / 8.74	
		48	5240			7.66 / 8.45	
	U-NII-2	52	5260	20	800/400	7.71 / 8.37	
		56	5280			7.71 / 8.45	
		60	5300			7.61 / 8.4	
		64	5320			7.63 / 8.48	
	U-NII-2e	100	5500	20	800/400	7.6 / 8.52	
		104	5520			7.53 / 8.44	
		108	5540			7.23 / 8.37	
		112	5560			7.26 / 8.4	
		116	5580			7.26 / 8.31	
		120	5600			7.02 / 8.02	
		124	5620			6.96 / 8	
		128	5640			N/A	
		132	5660			N/A	
		136	5680			6.51 / 7.49	
	U-NII-3	149	5745	20	800/400	6.35 / 7.27	
		153	5765			6.35 / 7.18	
		157	5785			6.22 / 6.81	
		161	5805			6.3 / 6.8	
		165	5825			6.32 / 6.75	
						6.33 / 6.73	
			6.4 / 6.62				

antenna: MAIN

IEEE 802.11n / 40 MHz / 1 Stream															
Mode	Band	Channel	Frequency	Bandwidth [MHz]	Guard Interval [ns]	Source-based time average power [dBm]									
						Data Rate [Mbps]									
						MCS0	MCS1	MCS2	MCS3	MCS4	MCS5	MCS6	MCS7		
						13.5/15	27/30	40.5/45	54/60	81/90	108/120	121.5/135	135/150		
IEEE 802.11n	U-NII-1	36	5190	40	800/400	7.85	7.75	7.34	7.08	6.66	6.31	6.21	5.89		
		40	5200			8.03	7.72	7.29	7.19	6.62	6.24	6.22	5.99		
		44	5230												
		48	5240												
	U-NII-2	52	5270	40	800/400	8.03	7.75	7.32	7.08	6.65	6.31	6.02	5.97		
		56	5280			8.02	7.58	7.29	7.05	6.61	6.24	6.08	6.02		
		60	5310												
		64	5320												
	U-NII-2e	100	5510	40	800/400	6.85	6.54	6.27	5.88	5.44	5.05	4.94	4.79		
		104	5520			6.58	6.30	6.04	5.74	5.16	4.71	4.70	4.60		
		108	5550												
		112	5560												
		116	5590			6.16	6.00	5.70	5.44	5.01	4.56	4.43	4.23		
		120	5600												
		124	5630												
		128	5640			N/A	N/A	N/A	N/A	N/A	N/A	N/A	N/A	N/A	
		132	5670			5.95	5.52	5.35	5.01	4.50	4.18	3.92	3.86		
		136	5680												
	U-NII-3	149	5755	40	800/400	5.90	5.57	5.28	4.91	4.30	4.10	3.94	3.59		
		153	5765			5.74	5.56	5.23	4.94	4.50	4.05	3.95	3.70		
		157	5795												
		161	5805												
		165	5825												

IEEE 802.11n / 40 MHz / 2 Streams						
Mode	Band	Channel	Frequency	Bandwidth [MHz]	Guard Interval [ns]	Source-based time average power [dBm]
						Data Rate [Mbps]
						MCS8
						27/30
IEEE 802.11n	U-NII-1	36	5190	40	800/400	7.52 / 8.41
		40	5200			
		44	5230			7.51 / 8.39
		48	5240			
	U-NII-2	52	5270	40	800/400	7.41 / 8.42
		56	5280			
		60	5310			7.47 / 8.43
		64	5320			
	U-NII-2e	100	5510	40	800/400	6.39 / 7.78
		104	5520			
		108	5550			6.08 / 7.53
		112	5560			
		116	5590			5.9 / 7.29
		120	5600			
		124	5630			N/A
		128	5640			
		132	5670			5.52 / 6.63
		136	5680			
	U-NII-3	149	5755	40	800/400	5.5 / 6.08
		153	5765			
		157	5795			5.37 / 6.07
		161	5805			
		165	5825			

In n-mode (HT 20 / HT 40, MCS8-15) the MAIN and AUX antenna are both active at the same time. MCS 8 represent the lowest Data Rate.

According to KDB 248227 v01r02 SAR measurements for 802.11n are not necessary because the conducted power values are not more than ¼ dB higher than the power values for 802.11a.

According to KDB 248227 v01r02 SAR measurements are performed for 802.11a and the lowest data rate of 6 Mbps.

### 1.6 Standalone Operational Mode Test Exclusion

According to KDB 447498 D01 v05r02 for standalone SAR evaluation the test exclusion power condition is given by

$$\frac{\text{max Power, mW}}{\text{test distance, mm}} \cdot \sqrt{f_{\text{GHz}}} \leq 3.0$$

for test separation distance ≤ 50mm. For test separation distances > 50mm, the SAR test exclusion threshold is:

$$P_{TH}[\text{mW}] = \text{Power allowed at numeric threshold for 50mm} + (\text{test distance, mm} - 50\text{mm}) \cdot \frac{f[\text{MHz}]}{150},$$

100 MHz < f < 1500 MHz

$$P_{TH}[\text{mW}] = \text{Power allowed at numeric threshold for 50mm} + (\text{test distance, mm} - 50\text{mm}) \cdot 10,$$

1500 MHz < f < 6 GHz

Mode	Pmax [mW]	Antenna	Top		Left		Right		Bottom		Back		Front	
			Antenna distance to user [mm]	SAR Test Exclusion Threshold [mW]	Antenna distance to user [mm]	SAR Test Exclusion Threshold [mW]	Antenna distance to user [mm]	SAR Test Exclusion Threshold [mW]	Antenna distance to user [mm]	SAR Test Exclusion Threshold [mW]	Antenna distance to user [mm]	SAR Test Exclusion Threshold [mW]	Antenna distance to user [mm]	SAR Test Exclusion Threshold [mW]
GPRS 850; 836.6 MHz, TS 3	300.61	Cellular MAIN	5	16	74	298	148	711	181	895	5	16		
GPRS 1900; 1880 MHz, TS 3	141.91	Cellular MAIN	5	11	74	349	148	1089	181	1419	5	11		
FDD II; 1880 MHz, RMC 12.2 kbps	200.91	Cellular MAIN	5	11	74	349	148	1089	181	1419	5	11		
FDD IV; 1732.6 MHz, RMC 12.2 kbps	225.424	Cellular MAIN	5	11	74	354	148	1094	181	1424	5	11		
FDD V; 826.4 MHz, RMC 12.2 kbps	219.28	Cellular MAIN	5	17	74	297	148	705	181	887	5	17		
FDD 2; 1880MHz, QPSK (1;99)	198.61	Cellular MAIN	5	11	74	349	148	1089	181	1419	5	11		
FDD 4; 1732.5 MHz, QPSK (1;0)	199.99	Cellular MAIN	5	11	74	354	148	1094	181	1424	5	11		
FDD 5; 836.5 MHz, QPSK (25;0)	228.03	Cellular MAIN	5	16	74	298	148	711	181	895	5	16		
FDD 13; 782 MHz, QPSK (1;49)	226.46	Cellular MAIN	5	17	74	295	148	681	181	853	5	17		
FDD 17; 710 MHz, QPSK (1;49)	233.35	Cellular MAIN	5	18	74	292	148	642	181	798	5	18		
Bluetooth; 2480 MHz, GFSK	7.57	WLAN MAIN	24	46	269	2285	5	10	146	1055	5	10		
IEEE 802.11b; 2462 MHz, 1Mbps	12.39	WLAN MAIN	24	46	269	2286	5	10	146	1056	5	10		
IEEE 802.11a; 5240 MHz, 6Mbps	14.76	WLAN MAIN	24	32	269	2256	5	7	146	1026	5	7		
IEEE 802.11a; 5280 MHz, 6Mbps	14.69	WLAN MAIN	24	31	269	225	5	7	146	1025	5	7		
IEEE 802.11a; 5500 MHz, 6Mbps	12.02	WLAN MAIN	24	31	269	2254	5	6	146	1024	5	6		
IEEE 802.11a; 5805 MHz, 6Mbps	9.62	WLAN MAIN	24	30	269	2252	5	6	146	1022	5	6		

For all operating modes for which the maximum source-based average output power is larger than the corresponding SAR test exclusion threshold power level (blue fields in table above), SAR measurement was performed.

According to KDB 616217 D04 v01r01 for the front side of the tablet no SAR measurement has to be performed because the edge is more than 20cm from the human body.

**1.7 Supported concurrent (multi-transmitter) operating modes**

The ability of all other transmitters to transmit simultaneously is given in the following table:

	<b>Bluetooth</b>	<b>WLAN b/g/n</b>	<b>WLAN a/n</b>	<b>GSM/UMTS/LTE</b>
<b>Bluetooth</b>	N/A	N/A	N/A	Yes
<b>WLAN b/g/n</b>	N/A	N/A	N/A	Yes
<b>WLAN a/n</b>	N/A	N/A	N/A	Yes
<b>GSM/UMTS/LTE</b>	Yes	Yes	Yes	N/A

### 1.8 Supported use cases

Use case	Distance to human body	corresponding test configuration
EUT placed at human body	0 mm (worstcase)Left	body-worn device
EUT placed at human body	0 mm (worstcase)Right	body-worn device
EUT placed at human body	12 mm (Top)	body-worn device proximity sensor off
EUT placed at human body	14 mm (Back)	body-worn device proximity sensor on

### 1.9 Proximity Sensors

The Tablet use capacitive proximity sensors to reduce the power in cellular mode. The proximity sensor does not have an effect to WLAN or Bluetooth.

The proximity sensors are located near the cellular main antenna and trigger only on the back side and on the top side.

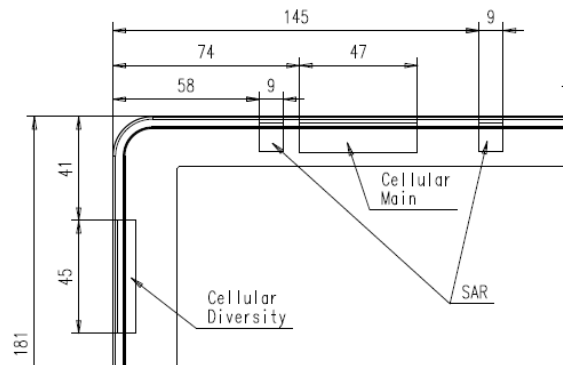

The proximity sensor triggering distances was measured according KDB 616217 D04 v01r01.

Back Side triggering distance in 3mm steps toward the phantom							
20mm	17mm	14mm	11mm	8mm	5mm	2mm	0mm
off	off	on	on	on	on	on	on

Back Side triggering distance in 3mm steps away from phantom									
0mm	3mm	6mm	9mm	12mm	15mm	18mm	21mm	24mm	27mm
off	off	on	on	on	on	off	off	off	off



Back Side triggering distance in 1mm steps toward the phantom										
19mm	18mm	17mm	16mm	15mm	14mm	13mm	12mm	11mm	10mm	9mm
off	off	off	off	on	on	on	on	on	on	on

Back Side triggering distance in 1mm steps away from phantom										
9mm	10mm	11mm	12mm	13mm	14mm	15mm	16mm	17mm	18mm	19mm
on	on	on	on	on	on	on	off	off	off	off

Top Side triggering distance in 3mm steps toward the phantom							
20mm	17mm	14mm	11mm	8mm	5mm	2mm	0mm
off	off	off	on	on	on	on	on

Top Side triggering distance in 3mm steps away from phantom									
0mm	3mm	6mm	9mm	12mm	15mm	18mm	21mm	24mm	27mm
on	on	on	on	on	off	off	off	off	off

Top Side triggering distance in 1mm steps toward the phantom										
19mm	18mm	17mm	16mm	15mm	14mm	13mm	12mm	11mm	10mm	9mm
off	off	off	off	off	off	on	on	on	on	on

Top Side triggering distance in 1mm steps away from phantom										
9mm	10mm	11mm	12mm	13mm	14mm	15mm	16mm	17mm	18mm	19mm
on	on	on	on	on	off	off	off	off	off	off

Tilt angle triggering, distance 13mm away from phantom												
-50°	-45°	-40°	-30°	-20°	-10°	0°	10°	20°	30°	40°	45°	50°
off	on	on	on	on	on	on	on	on	on	on	on	on

**1.10 Radio Test Modes**

Mode	Settings
IEEE 802.11b	Modulation = DSSS Duty cycle = 100% Data rate = 1Mbps Power level = maximum
IEEE 802.11a	Modulation = OFDM Duty cycle = 100% Data rate = 6 Mbps Power level = maximum
GSM 850	Mode = GPRS Modulation = GMSK Duty cycle = 0.375 (3 Timeslot) Coding = CS1 Power level = Gamma 3
GSM 1900	Mode = GPRS Modulation = GMSK Duty cycle = 0.375 (3 Timeslot) Coding = CS1 Power level = Gamma 3
FDD II	Mode = RMC Modulation = QPSK Duty cycle = 1 Data rate = 12.2 kbps Power level = TPC All 1
FDD IV	Mode = RMC Modulation = QPSK Duty cycle = 1 Data rate = 12.2 kbps Power level = TPC All 1
FDD V	Mode = RMC Modulation = QPSK Duty cycle = 1 Data rate = 12.2 kbps Power level = TPC All 1
FDD 2	Modulation = QPSK Duty cycle = 1 Bandwidth = 20 MHz RB Size / Offset = 1 / 50 Power level = maximum

FDD 4	Modulation = QPSK Duty cycle = 1 Bandwidth = 20 MHz RB Size / Offset = 1 / 50 Power level = maximum
FDD 5	Modulation = QPSK Duty cycle = 1 Bandwidth = 10 MHz RB Size / Offset = 25 / 25 Power level = maximum
FDD 13	Modulation = QPSK Duty cycle = 1 Bandwidth = 10 MHz RB Size / Offset = 1 / 49 Power level = maximum
FDD 17	Modulation = QPSK Duty cycle = 1 Bandwidth = 20 MHz RB Size / Offset = 1 / 49 Power level = maximum

**1.11 Test Positions**

Position	Description
BACK-0MM	EUT back side directly touching the phantom.
RIGHT-0MM	EUT right side directly touching the phantom.
LEFT-0MM	EUT left side directly touching the phantom.
For GSM/W-CDMA/LTE with deactivated proximity sensor (maximum power), 1mm closer to the triggering distance (worst case)	
BACK-14MM	EUT back side with 14 mm distance to the phantom.
TOP-12MM	EUT top side with 12 mm distance to the phantom.

### 1.12 Test Equipment Used During Testing

SAR Measurement					
Description	Manufacturer	Model	Identifier	Cal. Date	Cal. Due
Stäubli Robot	Stäubli	RX90B L	EF00271	functional test	functional test
Stäubli Robot Controller	Stäubli	CS7MB	EF00272	functional test	functional test
DASY 5 Measurement Server	Schmid& Partner		EF00273	functional test	functional test
Control Pendant	Stäubli		EF00274	functional test	functional test
Dell Computer	Schmid& Partner	Intel	EF00275	functional test	functional test
Data Acquisition Electronics	Schmid& Partner	DAE3V1	EF00276	2014-09	2015-09
Dosimetric E-Field Probe	Schmid& Partner	ET3DV6	EF00279	2014-09	2015-09
Dosimetric E-Field Probe	Schmid& Partner	EX3DV4	EF00826	2014-09	2015-09
System Validation Kit	Schmid& Partner	D300V3	EF00299	2012-09	2015-09
System Validation Kit	Schmid& Partner	D450V3	EF00300	2012-09	2015-09
System Validation Kit	Schmid& Partner	D900V2	EF00281	2012-09	2015-09
System Validation Kit	Schmid& Partner	D1800V2	EF00282	2012-09	2015-09
System Validation Kit	Schmid& Partner	D1900V2	EF00283	2012-09	2015-09
System Validation Kit	Schmid& Partner	D2450V2	EF00284	2012-09	2015-09
System Validation Kit	Schmid& Partner	D5GHZV2	EF00827	2012-11	2015-11
Flat phantom	Schmid& Partner	V 4.4	EF00328	no calibration required	no calibration required
Oval flat phantom	Schmid& Partner	ELI 4	EF00289	functional test	functional test
Mounting Device	Schmid& Partner	V 3.1	EF00287	functional test	functional test
Millivoltmeter	Rohde & Schwarz	URV 5	EF00126	2013-08	2016-08
Power sensor	Rohde & Schwarz	NRV-Z2	EF00125	2013-04	2015-04
RF signal generator	Rohde & Schwarz	SMP 02	EF00165	2013-05	2015-05
Insertion unit	Rohde & Schwarz	URV5-Z4	EF00322	2014-09	2015-09
Directional Coupler	HP	HP 87300B	EF00288	functional test	functional test
Radio Communication Tester	Rohde & Schwarz	CMD65	EF00625	ICO (initial calibration only)	ICO (initial calibration only)
Universal Radio Communication Tester	Rohde & Schwarz	CMU 200	EF00304	2014-05	2015-05
Network Analyzer 300 kHz to 3 GHz	Agilent	8752C	EF00140	2014-06	2015-06
Dielectric Probe Kit	Agilent	85070C	EF00291	functional test	functional test
Dielectric Probe Kit	SPEAG	DAK-3.5	EF00945	2014-09	2015-09
DAK Measurement Software	SPEAG	DAKS	EF00965	-	-
Thermometer	LKM electronic GmbH	DTM3000	EF00967	2014-09	2015-09

## 2 Result Summary

OET Bulletin 65 Supplement C, RSS-102					
Product Specific Standard Section	Requirement – Test	Reference Method	Maximum SAR [W/kg]	Result	Remarks
OET Bulletin 65 Suppl. C Section 2 RSS-102 Section 3	Single-band conformity	KDB Publication 447498 KDB Publication 248227 KDB Publication 865664	1.150	PASS	
OET Bulletin 65 Suppl. C Section 2 RSS-102 Section 3	Multi-band conformity	KDB Publication 447498 KDB Publication 648474 KDB Publication 865664	1.578	PASS	
<b>Remarks:</b>					

### 3 Definitions

The specific absorption rate (SAR) is defined as the time derivative of the incremental energy ( $dW$ ) absorbed by (dissipated in) an incremental mass ( $dm$ ) contained in a volume element ( $dV$ ) of a given density ( $\rho_t$ ), expressed in watts per kilogram (W/kg)

$$\text{SAR} = d/dt (dW/dm) = d/dt (dW/\rho_t dV) = \sigma/\rho_t |E_t|^2$$

where

$$dW/dt = \int_V E \cdot J \, dV = \int_V \sigma E^2 \, dV$$

#### 3.1 Controlled Exposure

The general population/uncontrolled exposure limits are applicable to situations in which the general public may be exposed or in which persons who are exposed as a consequence of their employment may not be made fully aware of the potential for exposure or cannot exercise control over their exposure. Members of the general public would come under this category when exposure is not employment-related; for example, in the case of a wireless transmitter that exposes persons in its vicinity. Warning labels placed on low-power consumer devices such as cellular telephones are not considered sufficient to allow the device to be considered under the occupational/controlled category and the general population/uncontrolled exposure limits apply to these devices.

#### 3.2 Uncontrolled Exposure

In general, occupational/controlled exposure limits are applicable to situations in which persons are exposed as a consequence of their employment, who have been made fully aware of the potential for exposure and can exercise control over their exposure. This exposure category is also applicable when the exposure is of a transient nature due to incidental passage through a location where the exposure levels may be higher than the general population/uncontrolled limits, but the exposed person is fully aware of the potential for exposure and can exercise control over his or her exposure by leaving the area or by some other appropriate means. Awareness of the potential for RF exposure in a workplace or similar environment can be provided through specific training as part of a RF safety program. If appropriate, warning signs and labels can also be used to establish such awareness by providing prominent information on the risk of potential exposure and instructions on the risk of potential exposure and instructions on methods to minimize such exposure risks.

#### 3.3 Localized SAR

Compliance with the localized SAR limits is demonstrated using the head and trunk limit because this SAR limit is only half the limbs limit value. The values are obtained by SAR measurements according to EN 62209-2.

## 4 Localized SAR Measurement Equipment

The measurements were performed with Dasy5 automated near-field scanning system comprised of high precision robot, robot controller, computer, e-field probe, probe alignment unit, phantoms, non-conductive phone positioned and software extension.

### 4.1 Complete SAR DASY5 Measurement System

Measurements are performed using the DASY5 automated assessment system made by Schmid& Partner Engineering AG (SPEAG) in Zurich, Switzerland.

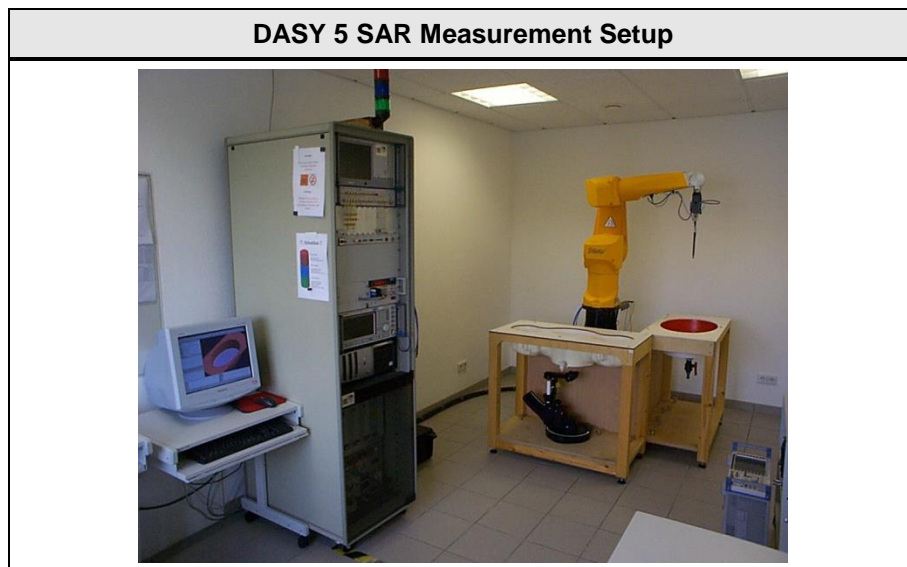

The following Diagram show the elements involved in the measurement setup.

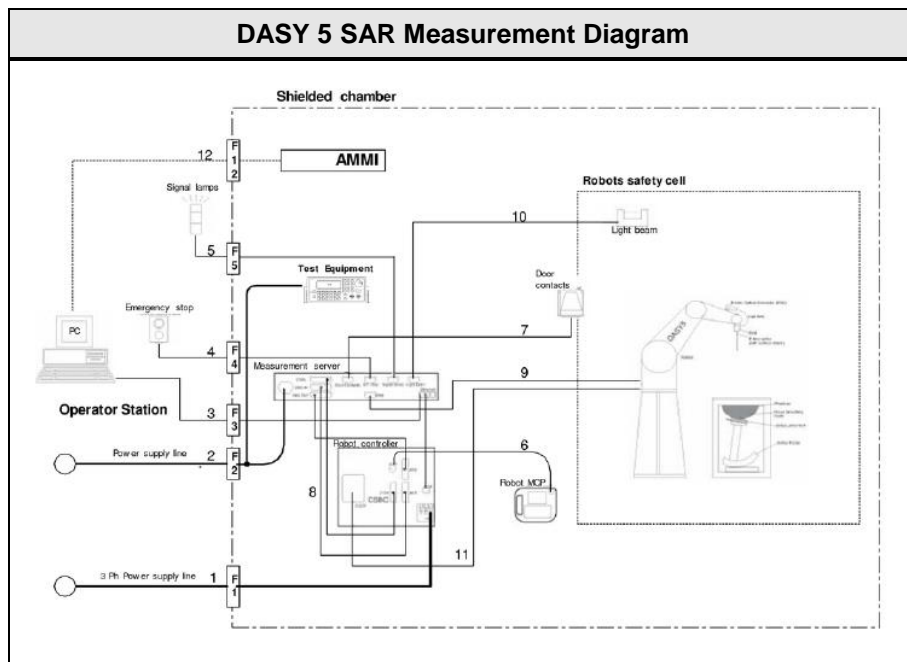



The DASY5 system for performing compliance tests consists of the following items:

<b>DASY5 SAR Measurement System</b>	
Device	Description:
RX90BL	A standard high precision 6-axis robot (Stäubli RX family) with controller, teach pendant and software.
Probe Alignment Unit	A probe alignment unit which improves the (absolute) accuracy of the probe positioning.
Teach Pendant	The Manual Control Pendant (MCP), also called the manual teach pendant, is the user interface to the robot. In DASY, it is used for certain installation and teach procedures
Signal Lamps	External warning lamp which indicates when the robot arm is powered-on and if the robot is under software control or in manual mode (controlled with the teach pendant).
DAE	The data acquisition electronics (DAE) which performs the signal amplification, signal multiplexing, AD-conversion, offset measurements, mechanical surface detection, collision detection, etc. The unit is battery powered with standard or rechargeable batteries. The signal is optically transmitted to the EOC.
E-Field Probes	Isotropic E-Field probe optimized and calibrated for E-field measurements in free space.
EOC	The electro-optical converter (EOC) performs the conversion between optical and electrical signals
Measurement Server	The functions of the measurement server is to perform the time critical task such as signal filtering, surveillance of the robot operation, fast movement interrupts.
Control Computer	A computer operating Windows 2000 or Windows NT with DASY 4 Software.
Control Software	DASY4 and SEMCAD post processing Software
SAM Twin Phantom	The SAM twin phantom enabling testing left-hand and right-hand usage.
Flat Phantom	Flat Phantom (only for body-mounted transceivers operating below 800 MHz).
Tissue simulating liquid	Tissue simulating liquid mixed according to the given recipes.
Device Holder	The device holder for handheld mobile phones.
System Validation Dipoles	System validation dipoles allowing to validate the proper functioning of the system.

#### 4.2 Robot Arm

The DASY5 system uses the high precision robots RX90BL type out of the newer series from Stäubli SA (France).

The RX robot series have many features that are important for our application:

- High precision (repeatability 0.02 mm)
- High reliability (industrial design)
- Jerk-free straight movements
- Low ELF interference (the closed metallic construction shields against motor control fields)
- 6-axis controller

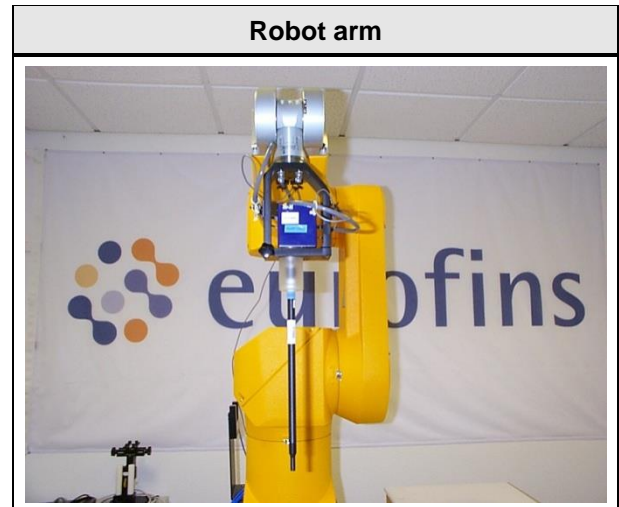

#### 4.3 Data Acquisition Electronics

The data acquisition electronics (DAE3) consists of a highly sensitive electrometer-grade preamplifier with auto-zeroing, a channel and gain-switching multiplexer, a fast 16 bit AD-converter and a command decoder and control logic unit. Transmission to the measurement server is accomplished through an optical downlink for data and status information as well as an optical uplink for commands and the clock.

The mechanical probe mounting device includes two different sensor systems for frontal and sideways probe contacts. They are used for mechanical surface detection and probe collision detection. The input impedance of the DAE3 is 200M Ohm; the inputs are symmetrical and floating. Common mode rejection is above 80dB.

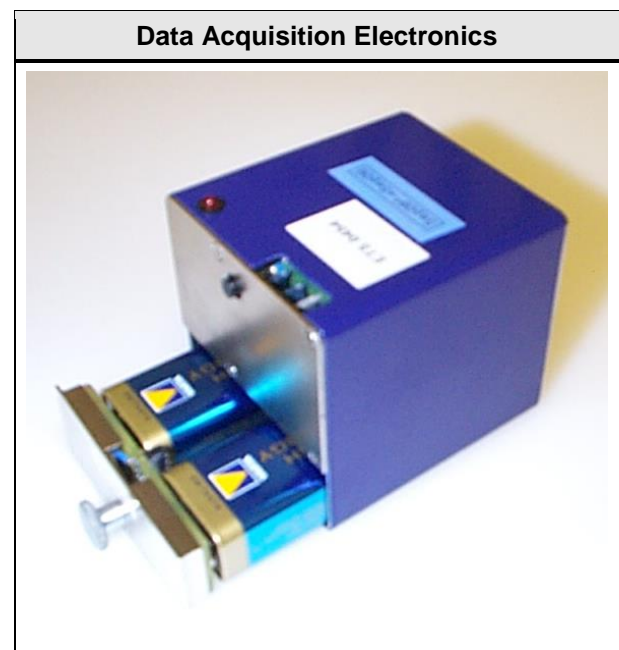

#### 4.4 Isotropic E-Field Probe $\leq 3$ GHz

##### Probe Specifications

###### **Construction:**

One dipole parallel, two dipoles normal to probe axis built-in shielding against static charges.

###### **Calibration:**

In air from 10 MHz to 2.5 GHz,  
In brain and muscle simulating tissue at  
Frequencies of 835MHz, 900MHz, 1800MHz,  
1900 MHz and 2450 MHz

###### **Frequency:**

10MHz to  $> 3$ GHz,  
Linearity  $\pm 0.2$ dB (30MHz to 3GHz)

###### **Directivity:**

$\pm 0.2$ dB in HSL (rotation around probe axis)  
 $\pm 0.4$ dB in HSL (rotation normal to probe axis)

###### **Dynamic Range:**

$5\mu$ W/g to  $> 100$ mW/g

###### **Linearity:**

$\pm 0.2$ dB

###### **Dimensions:**

Overall Length: 330mm (Tip: 16mm),  
Tip Diameter: 6.8mm (Body: 12mm),  
Distance from probe tip to dipole centers: 2.7mm

###### **Application:**

General dosimetry up to 3 GHz  
Compliance tests of mobile phones  
Fast automatic scanning in arbitrary phantoms



#### 4.5 Isotropic E-Field Probe $\leq 6$ GHz

##### Probe Specifications

###### **Construction:**

One dipole parallel, two dipoles normal to probe axis built-in shielding against static charges.

###### **Calibration:**

In air from 10 MHz to 6 GHz,  
In brain and muscle simulating tissue at  
Frequencies of 5200, 5500, 5800

###### **Frequency:**

10MHz to 6GHz,  
Linearity  $\pm 0.2$ dB (30MHz to 6GHz)

###### **Directivity:**

$\pm 0.3$ dB in HSL (rotation around probe axis)  
 $\pm 0.5$ dB in tissue material (rotation normal to probe axis)

###### **Dynamic Range:**

10 $\mu$ W/g to > 100mW/g

###### **Linearity:**

$\pm 0.2$ dB

###### **Dimensions:**

Overall Length: 337mm (Tip: 20mm),  
Tip Diameter: 2.5mm (Body: 12mm),  
Distance from probe tip to dipole centers: 1mm

###### **Application:**

General dosimetry up to 6 GHz  
Compliance tests of mobile phones  
Fast automatic scanning in arbitrary phantoms



#### 4.6 Test phantom and positioner

The positioner and test phantoms are manufactured by SPEAG. The test phantoms are used for all tests i.e. for both validation testing and device testing. The positioner and test phantom conforms to the requirements of EN 62209 and IEEE 1528.

The SPEAG device holder was used to position the test device in all tests whilst a tripod was used to position the validation dipoles in the test arch.

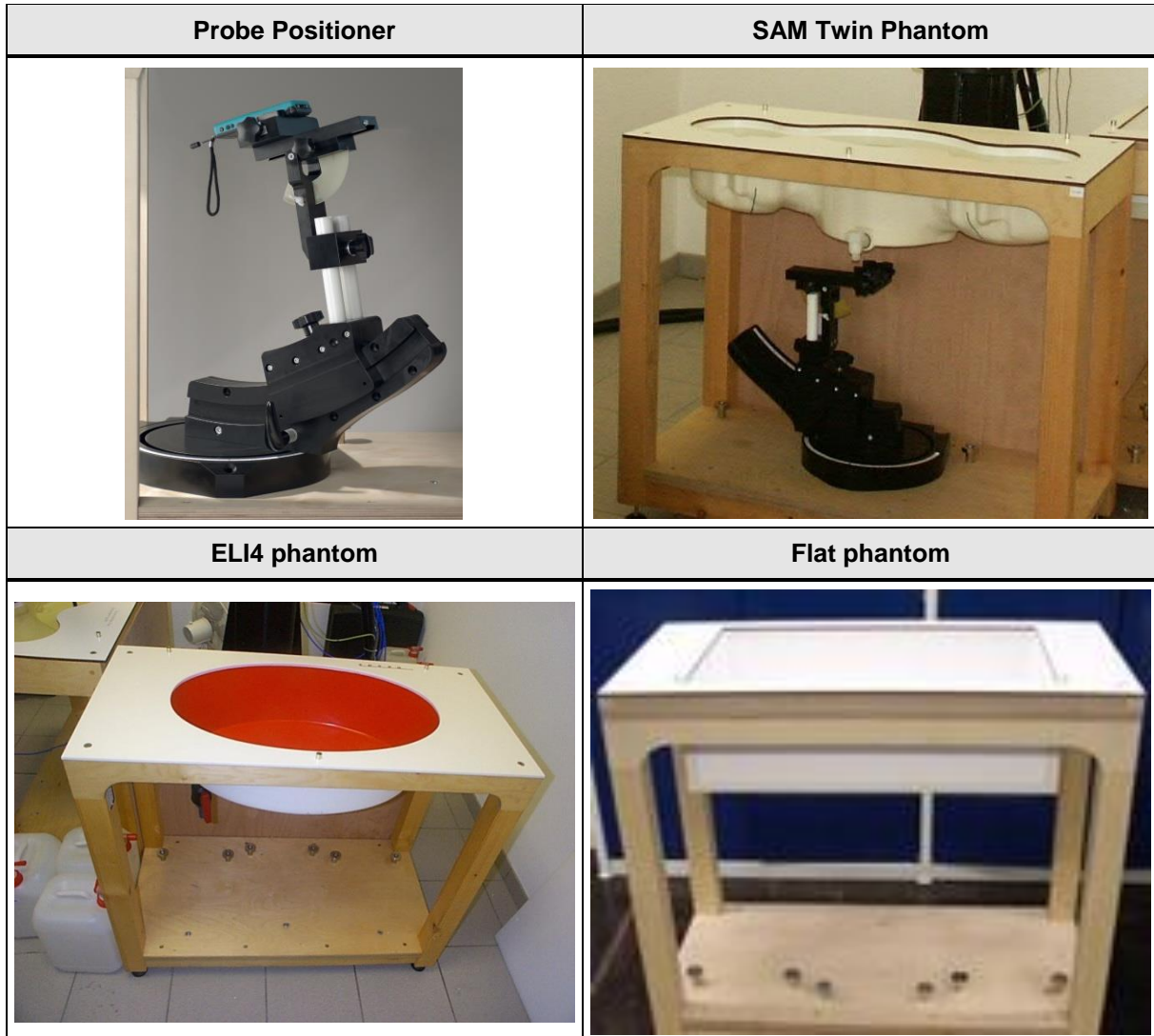



#### 4.7 System Validation Dipoles

A set of calibration dipoles (D750V2, D900V2, D1900V2, D1750V2, D2450V2, D5GHzV2) is included as a part of the SAR measurement setup. These are used for the validation of the test setup after its installation and prior to the EUT measurements. The calibration dipole is placed in the position normally occupied by the EUT. All calibration dipoles have the same height which allows an exact fitting below the center point of the test phantom. The dipole center is 10mm below the surface of the test phantom.

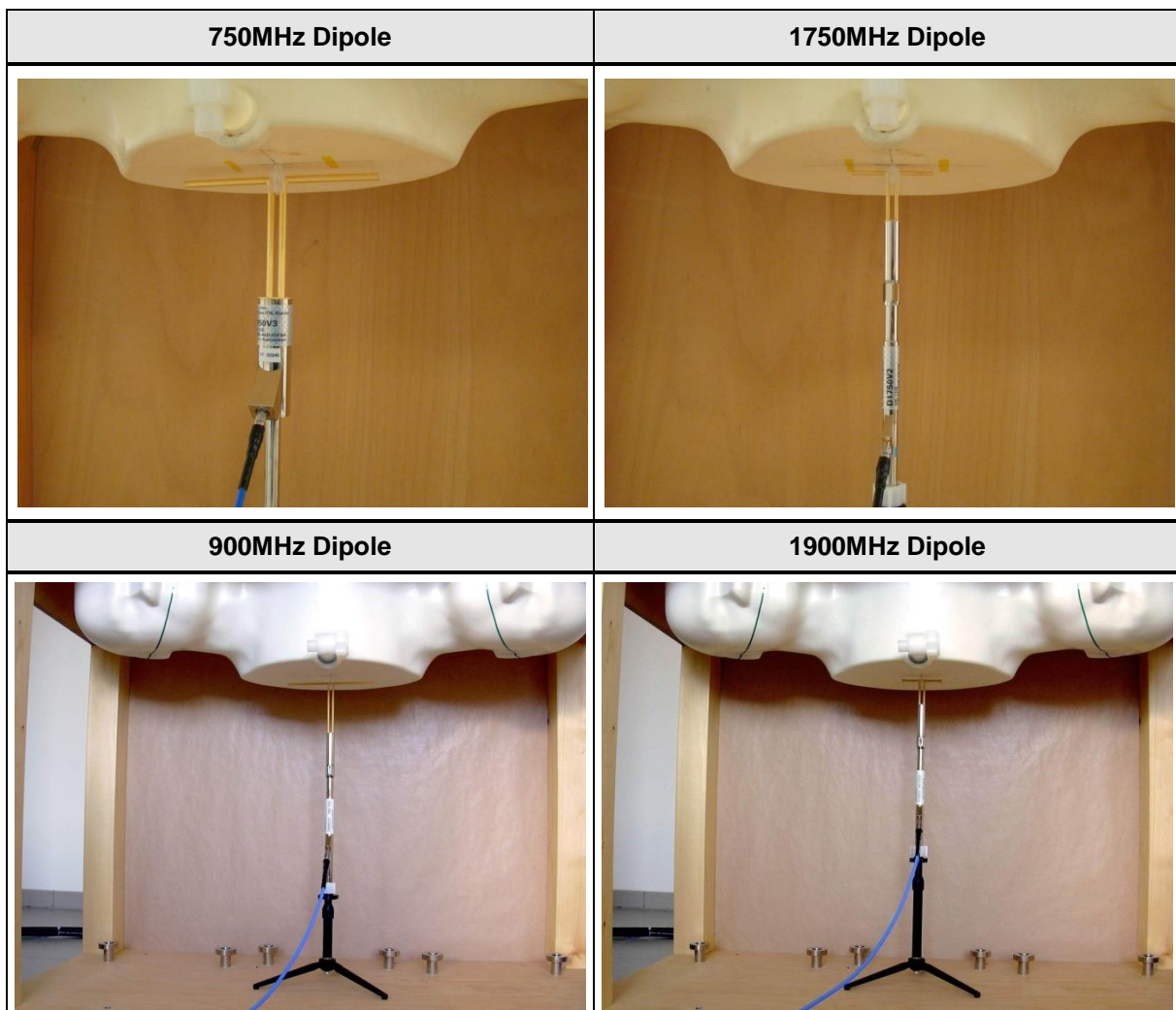

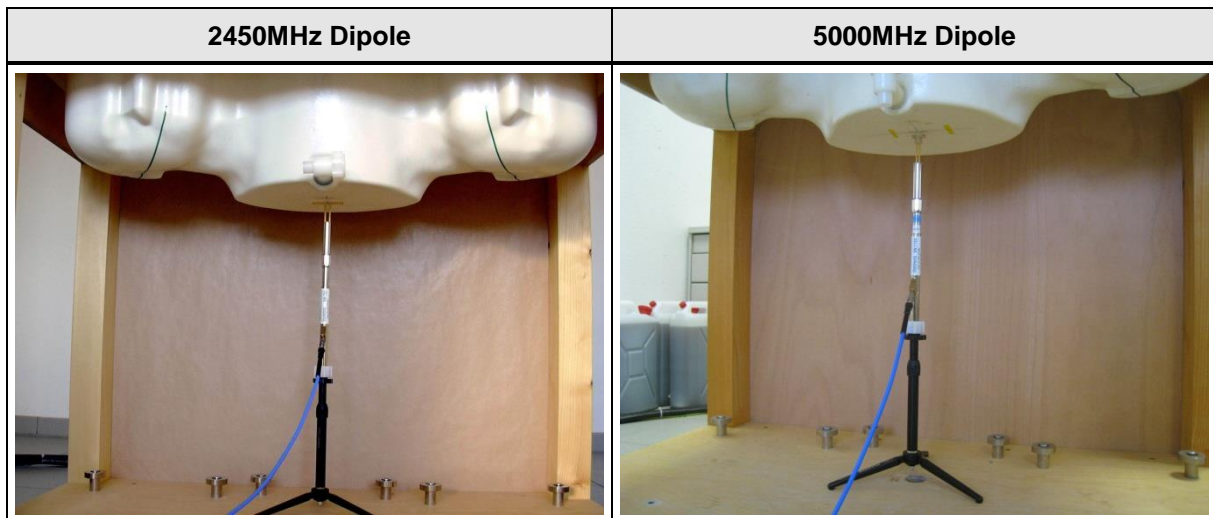

## 5 Single-band SAR Measurement

After successful completion of the tissue and system verification the SAR values of the EUT are measured according to the following description.

### 5.1 General measurement description

The measurement is performed for each frequency band of the device. If the width of the transmit frequency band exceeds 1% of its center frequency, then the channels at the lowest and highest frequencies should also be tested. Furthermore, if the width of the transmit band exceeds 10% of its center frequency the following formula is used to determine the number of channels:

$$N_C = 2 \cdot \text{roundup}[10 \cdot (f_{\text{high}} - f_{\text{low}}) / f_c] + 1$$

First the device is tested on the center channel of each frequency band used by the device. An operation mode and configuration with maximum transmit power is established. If battery operated equipment is used, the batteries are fully charged.

SAR measurements are performed using the steps outlined in the next section for all relevant operational modes, EUT configurations and measurement positions.

For the condition (position, configuration, operational mode) that provides the highest spatial-average SAR value on the center channel, the other channels are also tested.

Additionally all other conditions where the spatial-average SAR value is within 3dB of the SAR limit are also tested on all determined test frequencies.

### 5.2 SAR measurement description

First the local SAR value at a test point within 10mm or less in normal direction from the inner surface of the phantom is measured. This SAR value is used to determine the measurement drift during SAR measurement.

Next an area scan is performed over an area larger than the projection of the EUT with antenna on the surface of the phantom with a spatial grid step of 10mm.

From the scanned SAR distribution the position of maximum SAR value is identified as well as any local SAR maxima within 2dB of the maximum value that are not within the zoom scan volume. (The additional peaks are only measured when the primary peak is within 2dB of the SAR limit.)

The zoom-scan volume constructed on the peak SAR position is scanned with a grid step of 5mm. The measured data are extracted and the local SAR value for each measurement point is calculated. The measured values are interpolated over a fine-mesh within the scan volume and the average SAR value over 10g mass is calculated.

At the end of the measurement the reference point measured at the beginning of the measurement is measured again and from the difference the drift is calculated.



### 5.3 Reference lines and points for Handsets

For all measurement positions of the EUT, the EUT has to be placed in a specific orientation with respect to the phantom. The orientation of the EUT relative to the phantom is defined by reference lines and points.

According to IEEE 1528, the reference lines and points shall be positioned at the EUT as shown in the following figure.

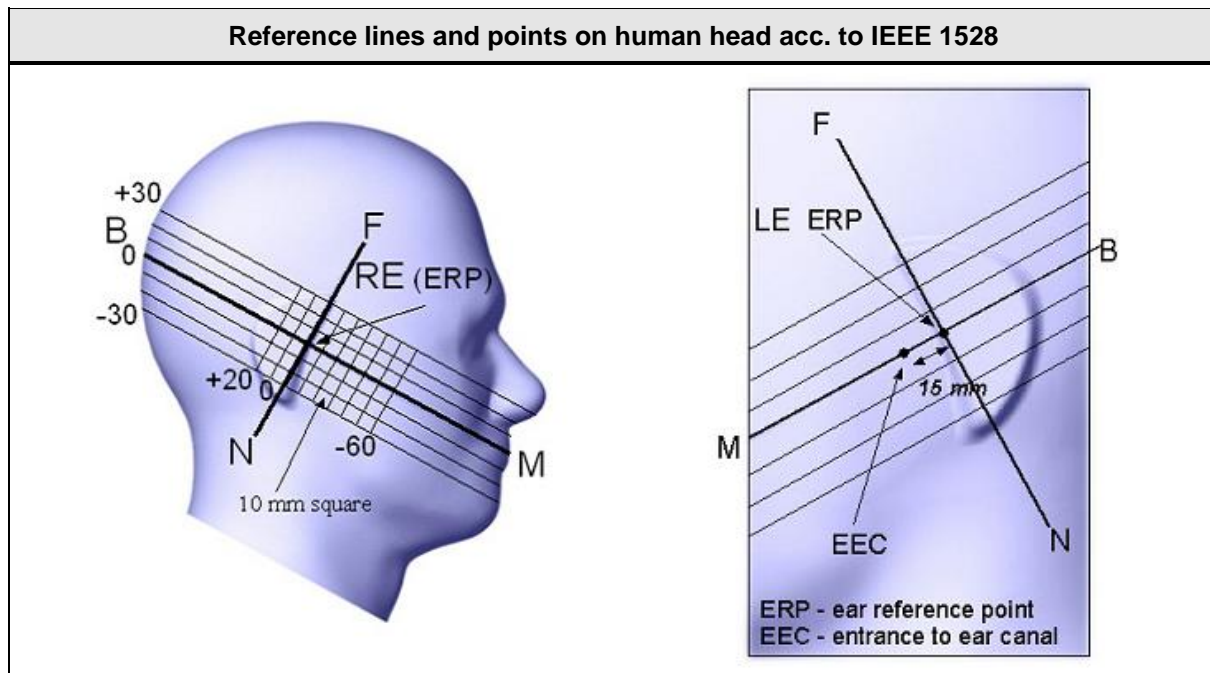
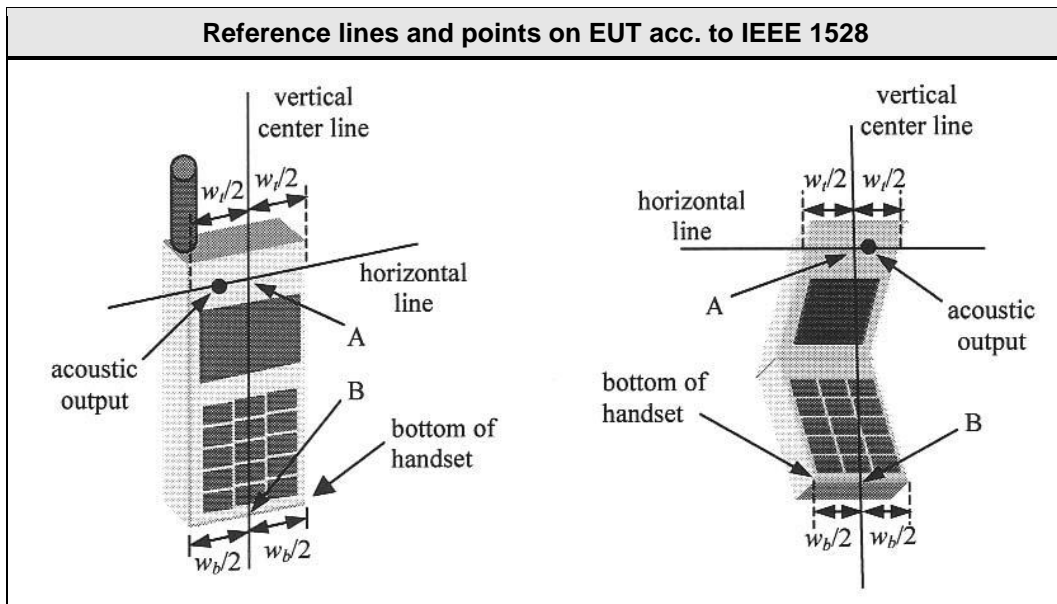

#### 5.4 Test positions relative to the Head

##### Cheekposition

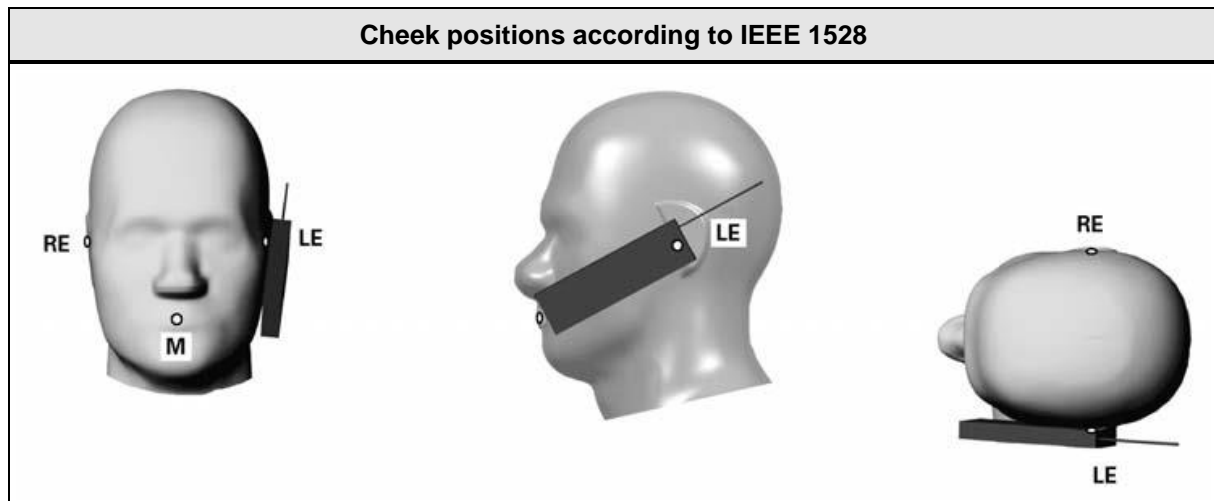

The handset is positioned close to the surface of the phantom such that point A is on the (virtual) extension of the line passing through points RE and LE on the phantom (see Figure), such that the plane defined by the vertical centerline and the horizontal line of the handset is approximately parallel to the sagittal plane of the phantom. Next the handset is translated towards the phantom along the line passing through RE and LE until handset point A touches the pinna at the ERP.

While the handset is maintained in this plane, it is rotated around the LE-RE line until the vertical centerline is in the plane normal to the plane containing B-M and N-F lines, i.e., the Reference Plane. Then it is rotated around the vertical centerline until the handset (horizontal line) is parallel to the N-F line. While the vertical centerline is maintained in the Reference Plane, point A is kept on the line passing through RE and LE, and the handset is maintained in contact with the pinna, the handset is rotated about the N-F line until any point on the handset is in contact with a phantom point below the pinna on the cheek.

##### Tiltposition

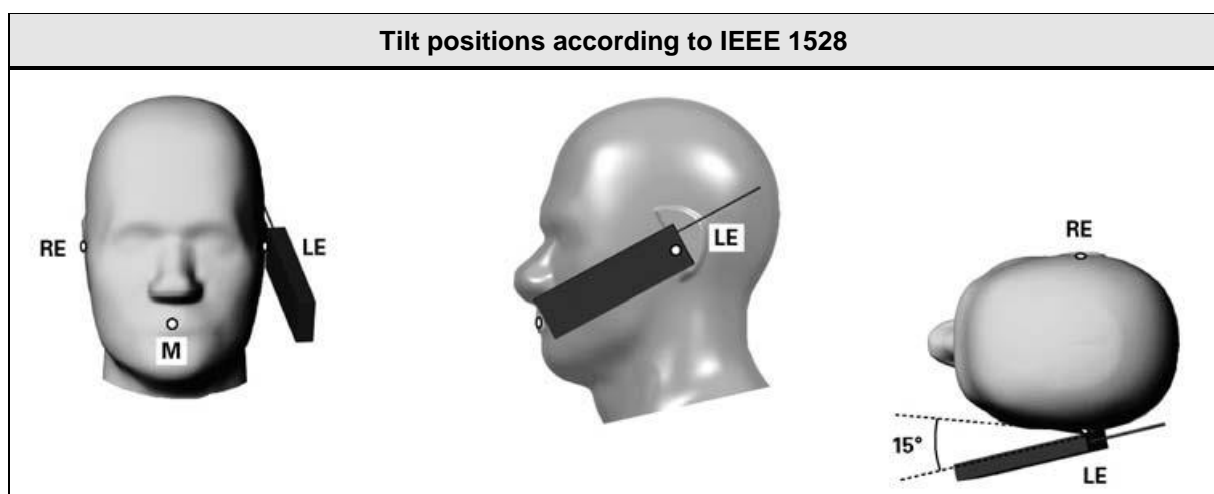

First the EUT is placed in the cheek position. Next the handset is moved away from the pinna along the line passing through RE and LE far enough to allow a rotation of the handset away from the cheek by 15°. Then the handset is rotated around the horizontal line by 15°.

The handset is moved towards the phantom on the line passing through RE and LE until any part of the handset touches the ear. The tilt position is obtained when the contact point is on the pinna. See Figure. If contact occurs at any location other than the pinna, e.g., the antenna at the back of the phantom head, the angle of the handset should be reduced. In this case, the tilt position is obtained if any point on the handset is in contact with the pinna and a second point on the handset is in contact with the phantom, e.g., the antenna with the back of the head

### 5.5 Test positions relative to the human body

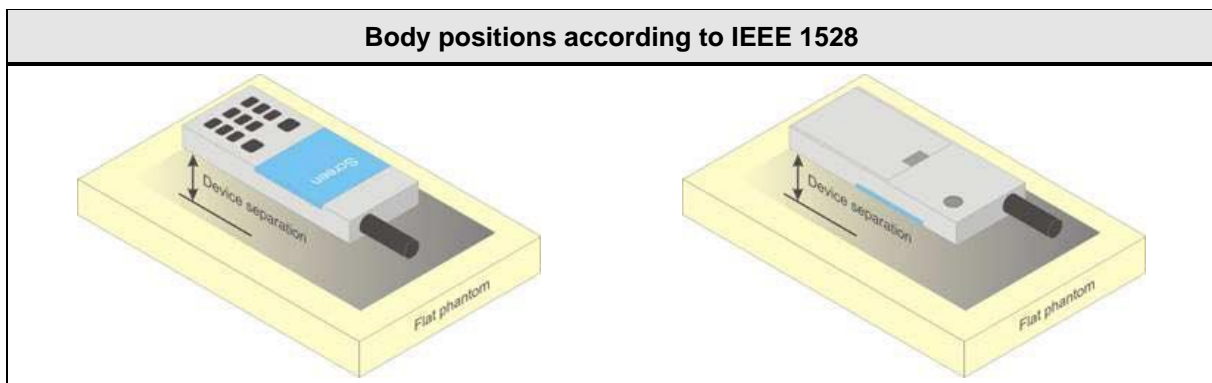

In body worn configuration the device is positioned parallel to the phantom surface with either top or bottom side of the EUT facing against the phantom.

The separation distance of the EUT is selected according to the use case of the EUT (e.g. with belt clip or holster).

## 5.6 Measurement Uncertainty

Measurement Uncertainty according to IEEE 1528							
Error Description	Uncertainty Value	Probability Distribution	Div.	c <sub>i</sub> (1g)	c <sub>i</sub> (10g)	Std. Unc. 1g	Std. Unc. 10g
<b>Measurement System</b>							
Probe Calibration	±6.55%	N	1	1	1	±6.55%	±6.55%
Axial Isotropy	±4.7%	R	$\sqrt{3}$	0.7	0.7	±1.9%	±1.9%
Hemispherical Isotropy	±9.6%	R	$\sqrt{3}$	0.7	0.7	±3.9%	±3.9%
Linearity	±4.7%	R	$\sqrt{3}$	1	1	±2.7%	±2.7%
Modulation Response	±2.4%	R	$\sqrt{3}$	1	1	±1.4%	±1.4%
System Detection Limits	±1.0%	R	$\sqrt{3}$	1	1	±0.6%	±0.6%
Boundary effects	±2.0%	R	$\sqrt{3}$	1	1	±1.2%	±1.2%
Readout Electronics	±0.3%	N	1	1	1	±0.3%	±0.3%
Response Time	±0.8%	R	$\sqrt{3}$	1	1	±0.5%	±0.5%
Integration Time	±2.6%	R	$\sqrt{3}$	1	1	±1.5%	±1.5%
RF Ambient Noise	±3.0%	R	$\sqrt{3}$	1	1	±1.7%	±1.7%
RF Ambient Reflections	±3.0%	R	$\sqrt{3}$	1	1	±1.7%	±1.7%
Probe Positioner	±0.8%	R	$\sqrt{3}$	1	1	±0.5%	±0.5%
Probe Positioning	±6.7%	R	$\sqrt{3}$	1	1	±3.9%	±3.9%
Post processing	±4.0%	R	$\sqrt{3}$	1	1	±2.3%	±2.3%
<b>Test Sample Related</b>							
Device Holder	±3.6%	N	1	1	1	±3.6%	±3.6%
Test Sample Positioning	±2.9%	N	1	1	1	±2.9%	±2.9%
Power Scaling	±0%	R	$\sqrt{3}$	1	1	±0%	±0%
Power Drift	±5.0%	R	$\sqrt{3}$	1	1	±2.9%	±2.9%
<b>Phantom and Setup Related</b>							
Phantom Uncertainty	±7.9%	R	$\sqrt{3}$	1	1	±4.6%	±4.6%
SAR correction	±1.9%	R	$\sqrt{3}$	1	0.84	±1.1%	±0.9%
Liquid conductivity (measured)	±2.5%	N	1	0.78	0.71	±2.0%	±1.8%
Liquid permittivity (measured)	±2.5%	N	1	0.26	0.26	±0.1%	±0.1%
Temperature uncertainty - Conductivity	±5.2%	R	$\sqrt{3}$	0.78	0.71	±2.3%	±2.1%
Temperature uncertainty - Permittivity	±0.8%	R	$\sqrt{3}$	0.23	0.26	±0.1%	±0.1%
Combined Standard Uncertainty						±12.8%	±12.7%

Test Report No.: G0M-1407-3981-TFC093SR-V01

Eurofins Product Service GmbH  
Storkower Str. 38c, D-15526 Reichenwalde, Germany

Measurement Uncertainty according to IEEE 1528							
Error Description	Uncertainty Value	Probability Distribution	Div.	c <sub>i</sub> (1g)	c <sub>i</sub> (10g)	Std. Unc. 1g	Std. Unc. 10g
Expanded Standard Uncertainty						±25.6%	±25.4%

## 6 Test Conditions and Results

### 6.1 Test Conditions and Results – Tissue Validation

Tissue Validation acc. To FCC OET Bulletin 65 Suppl. C / IC RSS-102					Verdict: PASS
Test according to measurement reference		Reference Method			
		OET Bulletin 65 Supplement C			
Target Values					
Frequency [MHz]	Head		Body		Permitted tolerance [%]
	Relative dielectric constant $\epsilon_r$	Conductivity $\sigma$ [S/m]	Relative dielectric constant $\epsilon_r$	Conductivity $\sigma$ [S/m]	
150	52.3	0.76	61.9	0.80	$\leq \pm 5$
300	45.3	0.87	58.2	0.92	$\leq \pm 5$
450	43.5	0.87	56.7	0.94	$\leq \pm 5$
750	41.9	0.89	55.5	0.96	$\leq \pm 5$
835	41.5	0.90	55.2	0.97	$\leq \pm 5$
900	41.5	0.97	55.0	1.05	$\leq \pm 5$
915	41.5	0.98	55.0	1.06	$\leq \pm 5$
1450	40.5	1.20	54.0	1.30	$\leq \pm 5$
1610	40.3	1.29	53.8	1.40	$\leq \pm 5$
1800 – 2000	40.0	1.40	53.3	1.52	$\leq \pm 5$
2450	39.2	1.80	52.7	1.95	$\leq \pm 5$
3000	38.5	2.40	52.0	2.73	$\leq \pm 5$
5200	36.0	4.66	49.0	5.30	$\leq \pm 5$
5500	35.6	4.96	48.6	5.65	$\leq \pm 5$
5800	35.3	5.27	48.2	6.00	$\leq \pm 5$

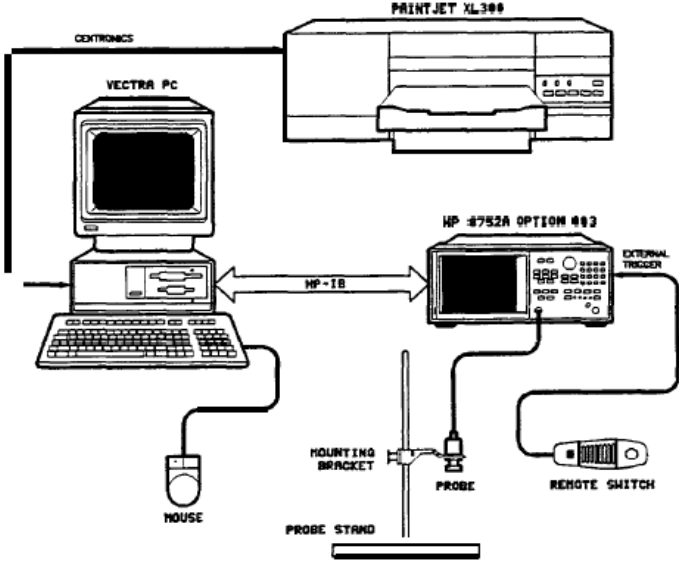
Test setup							
							
Test procedure							
<ol style="list-style-type: none"> <li>1. The dielectric probe kit is calibrated using the standards air, short circuit and deionized water</li> <li>2. The tissue simulating liquid is measured using the dielectric probe</li> <li>3. Target values are compared to the measurement values and deviations are determined</li> </ol>							
Test results							
Frequency [MHz]	Tissue	Measured $\epsilon_r$	Target $\epsilon_r$	Delta $\epsilon_r$ [%]	Measured $\sigma$ [S/m]	Target $\sigma$ [S/m]	Delta $\sigma$ [%]
750	Body	55	55.5	-0.90	0.96	0.96	0.00
900	Body	54.42	55.0	-1.10	1.03	1.05	-1.91
1750	Body	53.07	53.4	-0.62	1.56	1.49	4.6
1900	Body	54.37	53.3	2.0	1.46	1.52	-3.68
2450	Body	50.56	52.7	-4.06	2.02	1.95	3.60
5200	Body	47.7	49.0	-2.65	5.30	5.30	0.00
5500	Body	46.7	48.6	-3.91	5.68	5.65	0.53
5800	Body	46	48.2	-4.56	6.07	6.00	1.20
Comments:							

## 6.2 Test Conditions and Results – System Validation

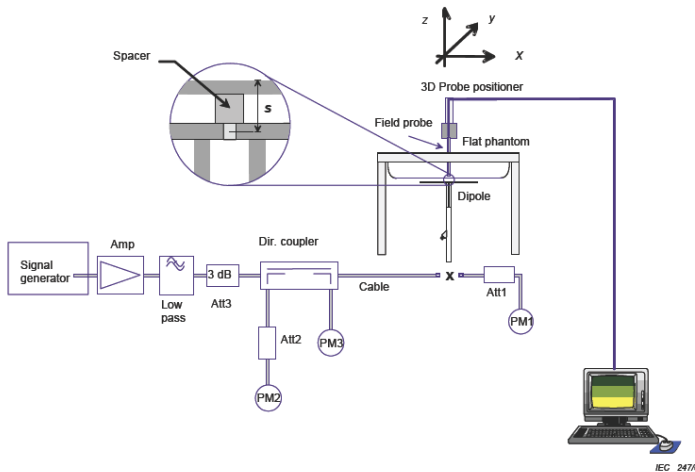
System Validation acc. to FCC OET Bulletin 65 Suppl. C / IC RSS-102		Verdict: PASS
Test according to measurement reference	Reference Method	
	OET Bulletin 65 Supplement C / IEEE 1528	
Test frequency range	Tested frequencies	
	750 MHz, 900 MHz, 1750 MHz, 1900 MHz, 2450 MHz , 5200 MHz, 5500 MHz, 5800 MHz	
Test mode	unmodulated CW	
Target Values		
Frequency [MHz]	Target SAR value [W/kg (1g)]	Permitted tolerance [%]
750	2.24 @ 250mW	≤±10
900	2.76 @ 250mW	≤±10
1750	9.33 @ 250mW	≤±10
1900	10.2 @ 250mW	≤±10
2450	12.9 @ 250mW	≤±10
5200	7.42 @ 100mW	≤±10
5500	7.97 @ 100mW	≤±10
5800	7.43 @ 100mW	≤±10
The target reference values are taken from the calibration sheets (see annex)		
Test setup		
		
Test procedure		
<ol style="list-style-type: none"> <li>1. The dipole antenna input power is set to 250mW</li> <li>2. The reference dipole is positioned under the phantom</li> <li>3. With the dipole antenna powered the SAR value is measured</li> <li>4. The measured SAR values are compared to the target SAR values</li> </ol>		



<b>Test results</b>				
Frequency [MHz]	Input power [mW]	Measured SAR value [W/kg (1g)]	Target SAR value [W/kg (1g)]	Delta [%]
900	250	2.8	2.76	1.45
900	250	2.71	2.76	-1.81
1750	250	9.15	9.50	-6.40
1900	250	9.24	10.2	-9.41
1900	250	9.46	10.2	-7.25
750	250	2.24	2.24	0.00
750	250	2.2	2.24	-8.30
2450	250	14.05	12.9	8.91
5200	100	7.26	7.42	-2.19
5500	100	7.43	7.97	-6.78
5800	100	6.95	7.43	-6.46
Comments:				

6.3 Test Conditions and Results – Standalone SAR Measurement

Standalone SAR acc. to FCC OET Bulletin 65 Suppl. C / IC RSS-102							Verdict: PASS	
Test according to measurement reference			Reference Method					
			FCC OET Bulletin 65 Supplement C / IC RSS-102 Issue 4					
Room temperature			22.0 – 22.6 °C					
Liquid depth			15.5 cm					
Environment			general public					
Limits								
Region			Occupational SAR values [W/kg]		General public SAR values [W/kg]			
Wholebodyaverage SAR			0.4		0.08			
Localized SAR (Head and trunk) SAR averaging mass = 10g			8		1.6			
Localized SAR (Limbs) SAR averaging mass = 10g			20		4			
Test results								
Mode	Position	Channel	Frequency [MHz]	Drift [dB]	Scaling Factor*	Measured SAR [W/kg (1g)]	Reported SAR [W/kg (1g)] **	SAR Limit [W/kg (1g)]
GPRS850	BACK 0mm	190	836.6	0.06	1.096	0.599	<b>0.657</b>	1.6
GPRS850	BACK 14mm	190	836.6	-0.19	1.096	0.534	0.586	1.6
GPRS850	LEFT 0mm	190	836.6	0.08	1.096	0.086	0.095	1.6
GPRS850	TOP 0mm	190	836.6	-0.09	1.096	0.398	0.436	1.6
GPRS850	TOP 12mm	190	836.6	-0.02	1.096	0.389	0.427	1.6
GPRS1900	BACK 0mm	661	1880	0.08	1.175	0.403	0.473	1.6
GPRS1900	BACK 14mm	661	1880	0.09	1.175	0.234	0.275	1.6
GPRS1900	LEFT 0mm	661	1880	-0.04	1.175	0.025	0.029	1.6
GPRS1900	TOP 0mm	661	1880	-0.09	1.175	0.461	<b>0.542</b>	1.6
GPRS1900	TOP 12mm	661	1880	0.19	1.175	0.264	0.310	1.6
FDD II	BACK 0mm	9262	1852.4	-0.01	1.340	0.543	0.728	1.6
FDD II	BACK 0mm	9400	1880	-0.02	1.340	0.593	0.832	1.6
FDD II	BACK 0mm	9538	1907.6	-0.10	1.340	0.486	0.651	1.6
FDD II	BACK 14mm	9400	1880	-0.01	1.340	0.478	0.640	1.6
FDD II	LEFT 0mm	9400	1880	-0.08	1.340	0.230	0.308	1.6
FDD II	TOP 0mm	9262	1852.4	-0.02	1.340	0.689	0.923	1.6
FDD II	TOP 0mm	9400	1880	-0.08	1.340	0.730	<b>0.978</b>	1.6
FDD II	TOP 0mm	9538	1907.6	-0.10	1.340	0.709	0.950	1.6
FDD II	TOP 12mm	9400	1880	-0.06	1.340	0.471	0.631	1.6

Test Report No.: G0M-1407-3981-TFC093SR-V01

FDD IV	BACK 0mm	1413	1732.6	-0.08	1.250	0.501	0.626	1.6
FDD IV	BACK 14mm	1413	1732.6	-0.15	1.250	0.446	0.558	1.6
FDD IV	LEFT 0mm	1413	1732.6	-0.16	1.250	0.547	0.684	1.6
FDD IV	TOP 0mm	1312	1712.4	-0.20	1.250	0.598	0.748	1.6
FDD IV	TOP 0mm	1413	1732.6	-0.08	1.250	0.676	<b>0.845</b>	1.6
FDD IV	TOP 0mm	1513	1752.6	-0.10	1.250	0.645	0.806	1.6
FDD IV	TOP 12mm	1413	1732.6	-0.06	1.250	0.427	0.534	1.6
FDD V	BACK 0mm	4233	846.6	-0.02	1.279	0.580	<b>0.742</b>	1.6
FDD V	BACK 14mm	4233	846.6	-0.10	1.279	0.563	0.720	1.6
FDD V	LEFT 0mm	4233	846.6	-0.05	1.279	0.056	0.072	1.6
FDD V	TOP 0mm	4233	846.6	-0.04	1.279	0.396	0.507	1.6
FDD V	TOP 12mm	4233	846.6	0.09	1.279	0.359	0.459	1.6
FDD 2	BACK 0mm	18900	1880	0.02	1.265	0.572	0.667	1.6
FDD 2	BACK 14mm	18900	1880	-0.07	1.265	0.354	0.448	1.6
FDD 2	LEFT 0mm	18900	1880	-0.06	1.265	0.229	0.290	1.6
FDD 2	TOP 0mm	18700	1860	-0.02	1.265	0.689	0.872	1.6
FDD 2	TOP 0mm	18900	1880	0.04	1.265	0.705	<b>0.892</b>	1.6
FDD 2	TOP 0mm	19100	1900	-0.08	1.265	0.654	0.827	1.6
FDD 2	TOP 12mm	18900	1880	-0.03	1.265	0.343	0.434	1.6
FDD 4	BACK 0mm	20175	1732.5	-0.08	1.274	0.501	0.638	1.6
FDD 4	BACK 14mm	20175	1732.5	0.07	1.274	0.357	0.455	1.6
FDD 4	LEFT 0mm	20175	1732.5	-0.01	1.274	0.233	0.297	1.6
FDD 4	TOP 0mm	20175	1732.5	0.00	1.274	0.652	<b>0.830</b>	1.6
FDD 4	TOP 12mm	20175	1732.5	-0.05	1.274	0.218	0.278	1.6
FDD 5	BACK 0mm	20525	836.5	-0.04	1.102	0.548	<b>0.600</b>	1.6
FDD 5	BACK 14mm	20525	836.5	0.06	1.102	0.449	0.495	1.6
FDD 5	LEFT 0mm	20525	836.5	0.01	1.102	0.283	0.312	1.6
FDD 5	TOP 0mm	20525	836.5	-0.06	1.102	0.290	0.319	1.6
FDD 5	TOP 12mm	20525	836.5	0.01	1.102	0.324	0.357	1.6
FDD 13	BACK 0mm	23230	782	-0.07	1.109	0.652	<b>0.723</b>	1.6
FDD 13	BACK 14mm	23230	782	-0.11	1.109	0.151	0.167	1.6
FDD 13	LEFT 0mm	23230	782	0.04	1.109	0.0406	0.045	1.6
FDD 13	TOP 0mm	23230	782	-0.13	1.109	0.349	0.387	1.6
FDD 13	TOP 12mm	23230	782	-0.02	1.109	0.134	0.149	1.6
FDD 17	BACK 0mm	23790	710	-0.03	1.076	0.484	<b>0.521</b>	1.6
FDD 17	BACK 14mm	23790	710	0.17	1.076	0.0602	0.065	1.6

Test Report No.: G0M-1407-3981-TFC093SR-V01

FDD 17	LEFT 0mm	23790	710	0.02	1.076	0.0169	0.018	1.6
FDD 17	TOP 0mm	23790	710	-0.14	1.076	0.296	0.319	1.6
FDD 17	TOP 12mm	23790	710	0.03	1.076	0.0466	0.050	1.6
IEEE 802.11b	BACK 0mm	11	2462	0.00	1.611	0.714	<b>1.150</b>	1.6
IEEE 802.11b	BACK 0mm	6	2412	-0.02	1.611	0.688	1.108	1.6
IEEE 802.11b	BACK 0mm	1	2437	0.08	1.611	0.594	0.957	1.6
IEEE 802.11b	RIGHT 0mm	11	2462	0.00	1.611	0.637	1.026	1.6
IEEE 802.11b	RIGHT 0mm	6	2412	-0.10	1.611	0.605	0.975	1.6
IEEE 802.11b	RIGHT 0mm	1	2437	0.02	1.611	0.613	0.988	1.6
IEEE 802.11a	BACK 0mm	48	5240	0.10	1.074	0.174	0.187	1.6
IEEE 802.11a	RIGHT 0mm	48	5240	0.01	1.074	0.272	0.292	1.6
IEEE 802.11a	BACK 0mm	56	5280	0.10	1.079	0.257	0.277	1.6
IEEE 802.11a	RIGHT 0mm	56	5280	0.07	1.079	0.379	0.409	1.6
IEEE 802.11a	BACK 0mm	100	5500	0.10	1.318	0.318	0.419	1.6
IEEE 802.11a	RIGHT 0mm	100	5500	0.10	1.318	0.350	0.461	1.6
IEEE 802.11a	BACK 0mm	161	5805	-0.08	1.648	0.156	0.257	1.6
IEEE 802.11a	RIGHT 0mm	161	5805	0.12	1.648	0.426	<b>0.702</b>	1.6
<b>Overall maximum SAR value [W/kg (1g)]</b>							<b>1.150</b>	<b>1.6</b>
Comments:*tune up tolerance / conducted power = scaling factor ** attached measurement plot: highest SAR value for the communication system								

SAR measurements were started with the highest power channel of the transmission band under investigation. Other measurement channels were omitted when the SAR value of the highest power channel was below 0.8 W/kg according to KDB 248227 v01r02.

According to KDB 865664 D02 v01r01 only the SAR plots for the highest SAR results for each EUT configuration and operating condition are given in the "SAR Results" part of the report.

**6.4 Test Conditions and Results – Multi-transmitter SAR Result**

Position	Max. SAR: GSM	Max. SAR: W-CDMA	Max. SAR: LTE	Max. SAR: IEEE 802.11 a/b	Bluetooth	Sum of 1g SAR	Ri (mm)	SPLSR	Sketch
Back	0.657			1.15		1.807	156.6	0.016	1
Top	0.542			0.4		0.942	N/A	N/A	
Left	0.095			0.4		0.495	N/A	N/A	
Right	0.4			1.026		1.426	N/A	N/A	
Back		0.832		1.15		1.982	172.4	0.016	2
Top		0.978		0.4		1.378	N/A	N/A	
Left		0.684		0.4		1.084	N/A	N/A	
Right		0.4		1.026		1.426	N/A	N/A	
Back			0.723	1.15		1.873	171.6	0.015	3
Top			0.892	0.4		1.292	N/A	N/A	
Left			0.312	0.4		0.712	N/A	N/A	
Right			0.4	1.026		1.426	N/A	N/A	
Back	0.657				0.318	0.975	N/A	N/A	
Top	0.542				0.4	0.942	N/A	N/A	
Left	0.095				0.318	0.413	N/A	N/A	
Right	0.4				0.4	0.8	N/A	N/A	
Back		0.832			0.318	1.15	N/A	N/A	
Top		0.978			0.4	1.378	N/A	N/A	
Left		0.684			0.318	1.002	N/A	N/A	
Right		0.4			0.4	0.8	N/A	N/A	
Back			0.723		0.318	1.041	N/A	N/A	
Top			0.892		0.4	1.292	N/A	N/A	
Left			0.312		0.318	0.63	N/A	N/A	
Right			0.4		0.4	0.8	N/A	N/A	

Sketch 1

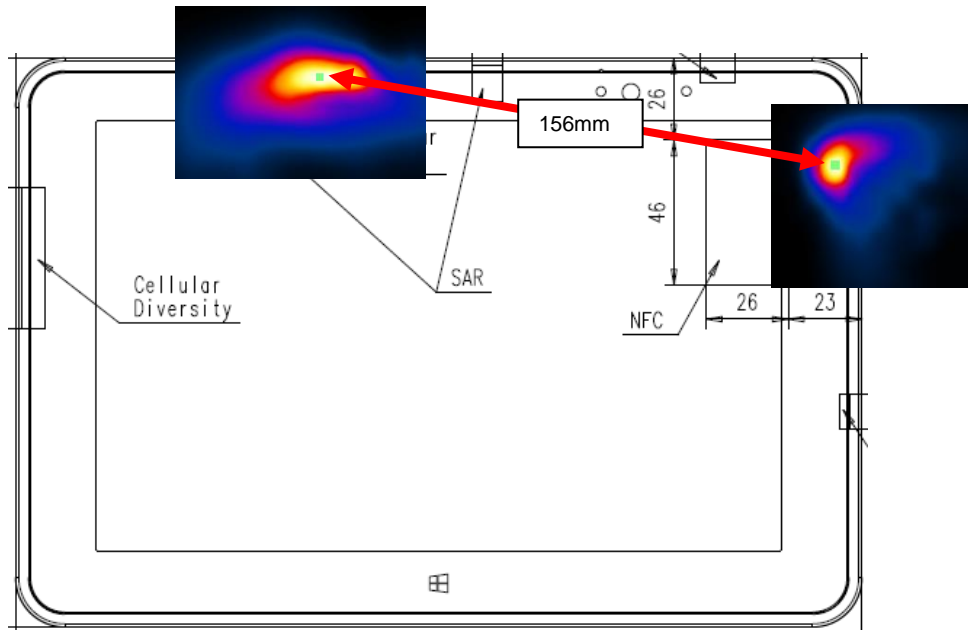

Sketch 2

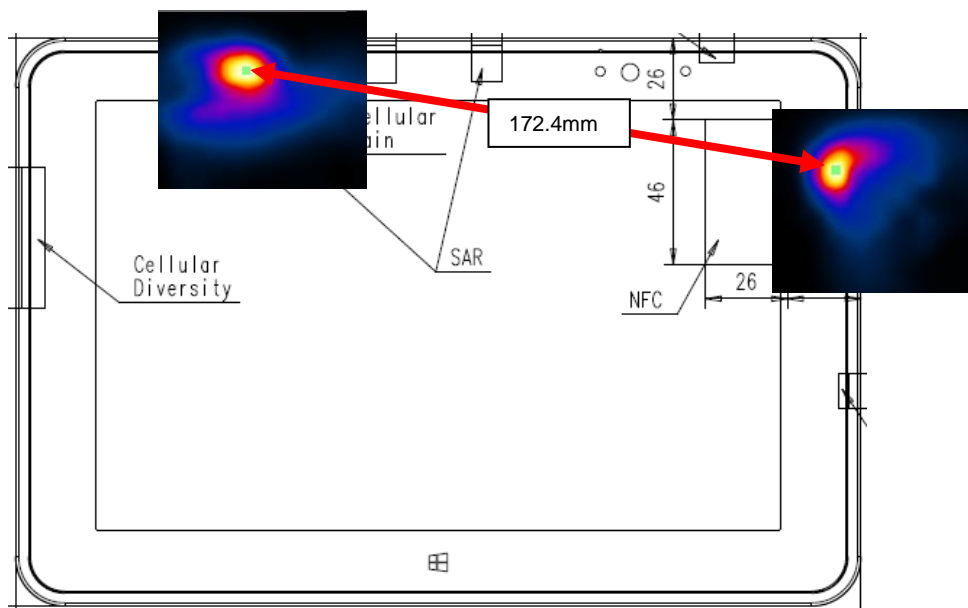

Sketch 3

