

TECHNICAL REPORT



ISO/IEC17025 Accredited Lab.

Report No: FCC1402031
File reference No: 2014-03-07

Applicant: Southern Telecom Inc.

Product: Wireless Headphone

Model No: ONA14AA011

Trademark: 

Test Standards: FCC Part 74H and Part 2

Test result: The test item passed the test specification(s)

Approved By

Jack Chung

Jack Chung
Manager

Dated: March 07, 2014

Results appearing herein relate only to the sample tested

The technical reports is issued errors and omissions exempt and is subject to withdrawal at

SHENZHEN TIMEWAY TECHNOLOGY CONSULTING CO LTD

5/F,Block 4, Anhua Industrial Zone.,No.8 TaiRan Rd.CheGongMiao,FuTian District, Shenzhen,CHINA.

Tel (755) 83448688

Fax (755) 83442996



Special Statement:

The testing quality ability of our laboratory meet with "Quality Law of People's Republic of China" Clause 19.

The testing quality system of our laboratory meets with ISO/IEC-17025 requirements, which is approved by CNAS. This approval result is accepted by MRA of APLAC.

Our test facility is recognized, certified, or accredited by the following organizations:

CNAS-LAB Code: L2292

The EMC Laboratory has been assessed and in compliance with CNAS-CL01 accreditation criteria for testing Laboratories (identical to ISO/IEC 17025:1999 General Requirements) for the Competence of testing Laboratories.

FCC-Registration No.: 899988

The EMC Laboratory has been registered and fully described in a report filed with the (FCC) Federal Communications commission. The acceptance letter from the FCC is maintained in our files. Registration No.:899988.

IC- Registration No.: IC5205A-02

The EMC Laboratory has been registered and fully described in a report filed with the (IC) Industry Canada. The acceptance letter from the IC is maintained in our files. Registration No.: IC 5205A-02.

The report refers only to the sample tested and does not apply to the bulk.

This report is issued in confidence to the client and it will be strictly treated as such by the Shenzhen Timeway Technology Consulting Co.,Ltd. It may not be reproduced in its entirety or in part and it may not be used for advertising. The client to whom the report is issued may, however, show or send it, or a certified copy thereof prepared by the Shenzhen Timeway Technology Consulting Co.,Ltd to his customer. Supplier or other persons directly concerned. Shenzhen Timeway Technology Consulting Co.,Ltd will not, without the consent of the client enter into any discussion of correspondence with any third party concerning the contents of the report.

In the event of the improper use of the report, The Shenzhen Timeway Technology Consulting Co.,Ltd reserves the rights to withdraw it and to adopt any other remedies which may be appropriate.



Test Report Conclusion
Content

1.0	General Details	4
1.1	Test Lab Details.....	4
1.2	Applicant Details.....	4
1.3	Description of EUT	4
1.4	Submitted Sample.....	4
1.5	Test Duration.....	5
1.6	Test Uncertainty.....	5
1.7	Test By.....	5
2.0	List of Measurement Equipment	5
3.0	Technical Details	6
3.1	Summary of Test Results.....	6
3.2	Test Standards.....	6
4.0	EUT Modification.....	6
5.0	Test Results	7
5.1	E.U.T. Operation Condition.....	7
5.2	Test Procedure & Measurement Data.....	7
5.2.1	Carrier Radiated Power & Radiated Spurious Emissions.....	7
5.2.2	Occupied Bandwidth.....	10
5.2.3	Frequency Stability.....	14
5.2.4	Modulation Characteristics.....	16
6.0	Power Line Conducted Emission Test	19
7.0	FCC ID Label	23
8.0	Photo of Test Setup and EUT View	24

The report refers only to the sample tested and does not apply to the bulk.
This report is issued in confidence to the client and it will be strictly treated as such by the Shenzhen Timeway Technology Consulting Co.,Ltd. It may not be reproduced rather in its entirety or in part and it may not be used for advertising. The client to whom the report is issued may, however, show or send it, or a certified copy thereof prepared by the Shenzhen Timeway Technology Consulting Co.,Ltd to his customer. Supplier or others persons directly concerned. Shenzhen Timeway Technology Consulting Co.,Ltd will not, without the consent of the client enter into any discussion of correspondence with any third party concerning the contents of the report.
In the event of the improper use of the report. The Shenzhen Timeway Technology Consulting Co.,Ltd reserves the rights to withdraw it and to adopt any other remedies which may be appropriate.



1.0 General Details

1.1 Test Lab Details

Name : SHENZHEN TIMEWAY TECHNOLOGY CONSULTING CO LTD
Address: 5/F,Block 4, Anhua Industrial Zone.,No.8 TaiRan Rd.CheGongMiao,FuTian District,
Shenzhen,CHINA.
Telephone: (755) 83448688
Fax: (755) 83442996
Site on File with the Federal Communications Commission – United States
Registration Number: 899988
For 3m & 10 m OATS
Site Listed with Industry Canada of Ottawa, Canada
Registration Number: IC: 5205A-02
For 3m & 10 m OATS

1.2 Applicant Details

Applicant: Southern Telecom Inc.
Address: Room 2707, Kerry Center, Renminnan Rd, Luohu district, Shenzhen
Telephone: 0755-25180778
Fax: 0755-25180783

1.3 Description of EUT

Product: Wireless Headphone
Trade Mark: 
Model Number: ONA14AA011
Additional Model Name N/A
Rating: DC3V (2 pcs AAA Batteries or powered by power supply)
Operation Frequency 84.922MHz
Necessary Bandwidth $2M+2DK=2*30kHz+2*20kHz*1.0=100kHz$
Antenna Designation Integral antenna with Gain 2.0dBi

1.4 Submitted Sample: 2 Sample

1.5 Test Duration

2014-02-19 to 2014-03-07

1.6 Test Uncertainty

Conducted Emissions Uncertainty =3.6dB
Radiated Emissions Uncertainty =4.7dB

The report refers only to the sample tested and does not apply to the bulk.

This report is issued in confidence to the client and it will be strictly treated as such by the Shenzhen Timeway Technology Consulting Co.,Ltd. It may not be reproduced in its entirety or in part and it may not be used for advertising. The client to whom the report is issued may, however, show or send it, or a certified copy thereof prepared by the Shenzhen Timeway Technology Consulting Co.,Ltd to his customer. Supplier or other persons directly concerned. Shenzhen Timeway Technology Consulting Co.,Ltd will not, without the consent of the client enter into any discussion of correspondence with any third party concerning the contents of the report. In the event of the improper use of the report. The Shenzhen Timeway Technology Consulting Co.,Ltd reserves the rights to withdraw it and to adopt any other remedies which may be appropriate.



1.7 Test Engineer

The sample tested by Terry Tang

Print Name: Terry Tang

2.0 Test Equipments					
Instrument Type	Manufacturer	Model	Serial No.	Date of Cal.	Due Date
ESPI Test Receiver	ROHDE&SCHWARZ	ESPI 3	100379	2013-08-23	2014-08-22
TWO Line-V-NETW	ROHDE&SCHWARZ	EZH3-Z5	100294	2013-08-23	2014-08-22
TWO Line-V-NETW	ROHDE&SCHWARZ	EZH3-Z5	100253	2013-08-23	2014-08-22
Ultra Broadband ANT	ROHDE&SCHWARZ	HL562	100157	2013-08-25	2014-08-24
ESDV Test Receiver	ROHDE&SCHWARZ	ESDV	100008	2013-08-23	2014-08-22
Impuls-Begrenzer	ROHDE&SCHWARZ	ESH3-Z2	100281	2013-08-24	2014-08-23
System Controller	CT	SC100	-	--	--
Loop Antenna	EMCO	6502	00042960	2013-08-23	2014-08-22
ESPI Test Receiver	ROHDE&SCHWARZ	ESI26	838786/013	2013-08-23	2014-08-22
3m OATS	--	--	N/A	2013-08-22	2014-08-21
Horn Antenna	SCHWARZBECK	BBHA 9170	BBHA9170265	2013-08-24	2014-08-23
Horn Antenna	SCHWARZBECK	BBHA 9120D	9120D-631	2013-08-24	2014-08-23
Power meter	Anritsu	ML2487A	6K00003613	2013-08-24	2014-08-23
Power sensor	Anritsu	MA2491A	32263	2013-08-24	2014-08-23
Bilog Antenna	Schwarebeck	VULB9163	9163/340	2013-08-24	2014-08-23
9*6*6 Anechoic	--	--	N/A	2013-08-22	2014-08-21
EMI Test Receiver	RS	ESCS30	100139	2013-08-23	2014-08-22
Modulation Analyzer	HP	8901B	3104A03667	2013-05-26	2014-05-25
Audio Signal Generator	Shanghai Radio Equipment Factory	S101A	J006C	2013-09-03	2014-09-02

The report refers only to the sample tested and does not apply to the bulk.

This report is issued in confidence to the client and it will be strictly treated as such by the Shenzhen Timeway Technology Consulting Co., Ltd. It may not be reproduced rather in its entirety or in part and it may not be used for advertising. The client to whom the report is issued may, however, show or send it, or a certified copy thereof prepared by the Shenzhen Timeway Technology Consulting Co., Ltd to his customer. Supplier or others persons directly concerned. Shenzhen Timeway Technology Consulting Co., Ltd will not, without the consent of the client enter into any discussion of correspondence with any third party concerning the contents of the report.

In the event of the improper use of the report. The Shenzhen Timeway Technology Consulting Co., Ltd reserves the rights to withdraw it and to adopt any other remedies which may be appropriate.



3.0 Technical Details

3.1 Summary of test results

The EUT has been tested according to the following specifications:			
Test Type	Test Requirement	Standard	Result
Carrier Radiated Power	FCC Part 2.1046	74.861 e) 1) 76M-88MHz—50mW	Pass
Modulation Deviation	FCC Part 2. 1047	74.861 e) 3) 74.861 e) 3) Within 75kHz	Pass
Frequency Stability	FCC Part 2. 1055	74.861 e) 4) <0.005% 50 ppm	Pass
Operating Bandwidth	FCC Part 2. 1049 c	74.861 e) 5) Within 200kHz	Pass
Unwanted Radiation	FCC Part 2. 1049 c	74.861 e) 6) Within the mask	Pass
Radiation Spurious Emission	FCC Part 2. 1053	74.861 e) 3) <43+10lgP(W)dB	Pass

3.2 Test Standards

FCC Part 74H and Part 2

4.0 EUT Modification

No modification by Shenzhen Timeway Technology Consulting Co.,Ltd

The report refers only to the sample tested and does not apply to the bulk.

This report is issued in confidence to the client and it will be strictly treated as such by the Shenzhen Timeway Technology Consulting Co.,Ltd. It may not be reproduced rather in its entirety or in part and it may not be used for advertising. The client to whom the report is issued may, however, show or send it, or a certified copy thereof prepared by the Shenzhen Timeway Technology Consulting Co.,Ltd to his customer. Supplier or other persons directly concerned. Shenzhen Timeway Technology Consulting Co.,Ltd will not, without the consent of the client enter into any discussion of correspondence with any third party concerning the contents of the report.

In the event of the improper use of the report. The Shenzhen Timeway Technology Consulting Co.,Ltd reserves the rights to withdraw it and to adopt any other remedies which may be appropriate.



5 Test Results

5.1 EUT Operation Condition

Operation Environment:

Temperature: 20.0 °C~25 °C

Humidity: 50~70% RH

Atmospheric Pressure: 980~1012 mbar

EUT Operation: Test the EUT in transmitting mode

5.2 Test Procedure & Measurement Data

5.2.1 Carrier Radiated Power & Radiated Spurious Emissions

Test Requirement: FCC CFR 47 Part 74.861 e) 1) & d) 3)

Test Method: EIA/TIA 603-C: 2004 section 2.2,
FCC CFR 47 Part 2.1047 & 1053

Measurement Distance: 3m (Semi-Anechoic Chamber)

Test Requirement:

(a) For low power auxiliary stations operating in the bands other than those allocated for TV broadcasting, the following technical requirements are imposed.

(b) The occupied bandwidth shall not be greater than that necessary for satisfactory transmission and, in any event, an emission appearing on any discrete frequency outside the authorized band shall be attenuated, at least, $43+10\log_{10}(\text{mean output power, in watts})$ dB below the mean output power of the transmitting unit.

(c) For low power auxiliary stations operating in the bands allocated for TV broadcasting, the following technical requirements apply:

(d) The power of the measured unmodulated carrier power at the output of the transmitter power amplifier (antenna input power) may not exceed the following:

(i) 54–72, 76–88, and 174–216 MHz bands—50 mW

(ii) 470–608 and 614–806 MHz bands—250 mW

Test Procedure:

The procedure used was EIA/TIA 603-C: 2004. The receiver was scanned from 30MHz to 10times carrier frequency. When an emission was found, the table was rotated to produce the maximum signal strength. An initial pre-scan was performed for in peak detection mode using the receiver. The EUT was measured for both the Horizontal and Vertical polarities and performed a pre-test three orthogonal planes. The field strength is calculated by adding the Antenna Factor, Cable Factor & Peramplifier. The basic equation with a sample calculation is as follows:

Final Test Level =Receiver Reading+Antenna Factor+Cable Factor–Peramlifer Factor

An initial pre-scan was performed in the 3m chamber using the spectrum analyser in peak detection mode. Quasi-peak measurements were conducted based on the peak sweep graph. The EUT was measured by Bilog antenna with 2 orthogonal polarities. Remove the EUT and replace it with substitution antenna. A signal generator was connected to the substitution antenna by a non-radiating cable. The absolute levels of the Carrier Radiated Power and spurious emissions were measured by the substitution.

The report refers only to the sample tested and does not apply to the bulk.

This report is issued in confidence to the client and it will be strictly treated as such by the Shenzhen Timeway Technology Consulting Co.,Ltd. It may not be reproduced rather in its entirety or in part and it may not be used for advertising. The client to whom the report is issued may, however, show or send it, or a certified copy thereof prepared by the Shenzhen Timeway Technology Consulting Co.,Ltd to his customer. Supplier or others persons directly concerned. Shenzhen Timeway Technology Consulting Co.,Ltd will not, without the consent of the client enter into any discussion of correspondence with any third party concerning the contents of the report.

In the event of the improper use of the report. The Shenzhen Timeway Technology Consulting Co.,Ltd reserves the rights to withdraw it and to adopt any other remedies which may be appropriate.



Block diagram of Test setup

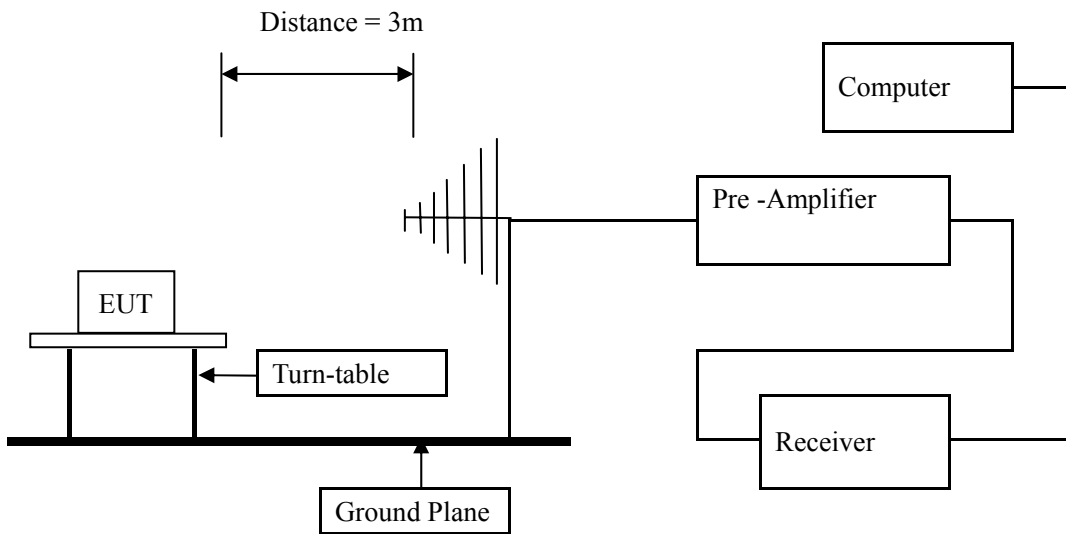

Carrier Output Power Setup

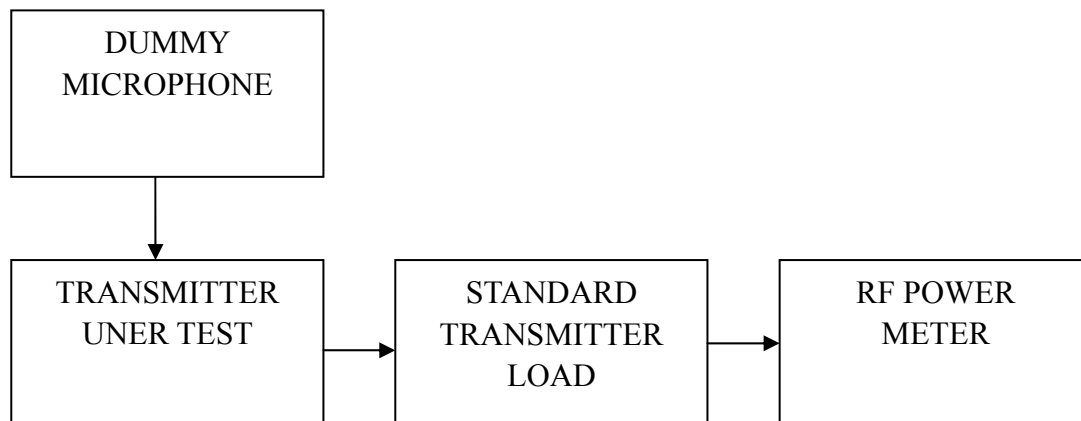

Test Result:

Carrier Frequency (MHz)	Factual Level dBm (mW)	Limit in 74.861 e) 1)
84.922	7.40dBm (i.e. 5.50 mW)	17dBm (i.e. 50 mW)

The Factual Level is conducted value.

The report refers only to the sample tested and does not apply to the bulk. This report is issued in confidence to the client and it will be strictly treated as such by the Shenzhen Timeway Technology Consulting Co., Ltd. It may not be reproduced rather in its entirety or in part and it may not be used for advertising. The client to whom the report is issued may, however, show or send it, or a certified copy thereof prepared by the Shenzhen Timeway Technology Consulting Co., Ltd. to his customer. Supplier or other persons directly concerned. Shenzhen Timeway Technology Consulting Co., Ltd. will not, without the consent of the client enter into any discussion of correspondence with any third party concerning the contents of the report. In the event of the improper use of the report, The Shenzhen Timeway Technology Consulting Co., Ltd reserves the rights to withdraw it and to adopt any other remedies which may be appropriate.



Radiated spurious emissions:

Spurious Emission Frequency (MHz)	Factual Level Horizontal (dBm)	Factual Level Vertical (dBm)	Limit (dBm)	Min Margin (dB)
169.52	-59.53	-66.69	-13.0	46.53
508.52	-52.75	-63.23	-13.0	39.75
339.00	-50.03	-64.00	-13.0	37.03

The Factual Level is ERP value.

TEST RESULTS: The unit does meet the FCC requirements.

The report refers only to the sample tested and does not apply to the bulk.
This report is issued in confidence to the client and it will be strictly treated as such by the Shenzhen Timeway Technology Consulting Co.,Ltd. It may not be reproduced rather in its entirety or in part and it may not be used for advertising. The client to whom the report is issued may, however, show or send it or a certified copy there of prepared by the Shenzhen Timeway Technology Consulting co.,Ltd to his customer. Supplier or others persons directly concerned. Shenzhen Timeway Technology Consulting co.,Ltd will not, without the consent of the client enter into any discussion of correspondence with any third party concerning the contents of the report.
In the event of the improper use of the report. The Shenzhen Timeway Technology Consulting co.,Ltd reserves the rights to withdraw it and to adopt any other remedies which may be appropriate.



5.2.2 Occupied Bandwidth

Test Requirement: FCC CFR 47 Part 74.e) 5) & 6)

Test Method: FCC CFR 47 Part 2.1049

Requirements:

(e) For low power auxiliary stations operating in the bands allocated for TV broadcasting, the following technical requirements apply:

(5) The operating bandwidth shall not exceed 200 kHz.

(6) The mean power of emissions shall be attenuated below the mean output power of the transmitter in accordance with the following schedule:

(i) On any frequency removed from the operating frequency by more than 50 percent up to and including 100 percent of the authorized bandwidth: at least 25dB;

(ii) On any frequency removed from the operating frequency by more than 100 percent up to and including 250 percent of the authorized bandwidth: at least 35dB;

(iii) On any frequency removed from the operating frequency by more than 250 percent of the authorized bandwidth: at least $43+10\log_{10}$ (mean output power in watts) dB.

Test Procedure

Setup

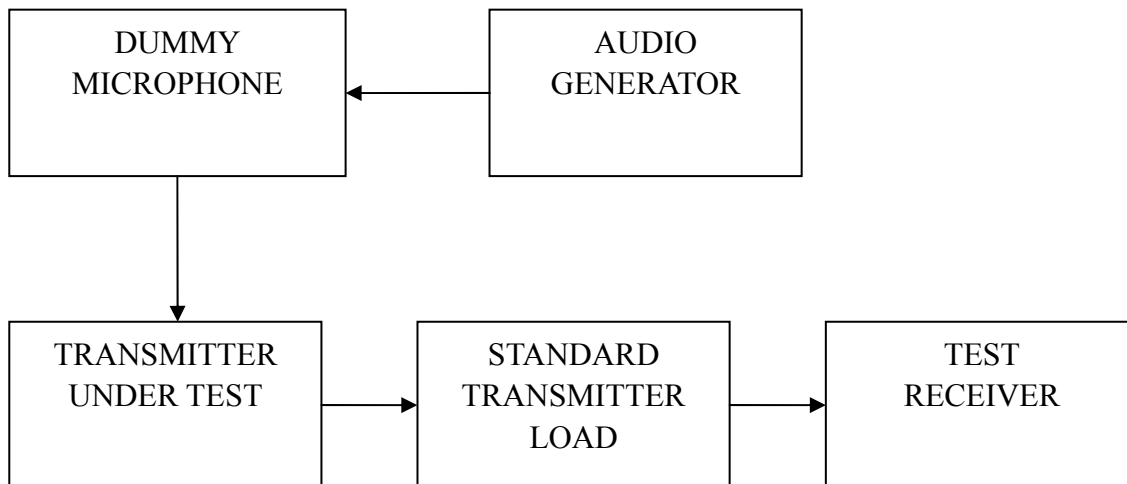

Input 2500Hz signal to the microphone, find the 50% rated deviation, add the level 16dB, test this status the 99% occupied bandwidth and record it.

The report refers only to the sample tested and does not apply to the bulk.

This report is issued in confidence to the client and it will be strictly treated as such by the Shenzhen Timeway Technology Consulting Co., Ltd. It may not be reproduced in its entirety or in part and it may not be used for advertising. The client to whom the report is issued may, however, show or send it, or a certified copy thereof prepared by the Shenzhen Timeway Technology Consulting Co., Ltd. to his customer, supplier or other persons directly concerned. Shenzhen Timeway Technology Consulting Co., Ltd. will not, without the consent of the client, enter into any discussion of correspondence with any third party concerning the contents of the report.

In the event of the improper use of the report, the Shenzhen Timeway Technology Consulting Co., Ltd. reserves the rights to withdraw it and to adopt any other remedies which may be appropriate.



Test Result: The graph as below represents the emissions take for this device.

Occupied Bandwidth (99% of total power): 67 kHz.

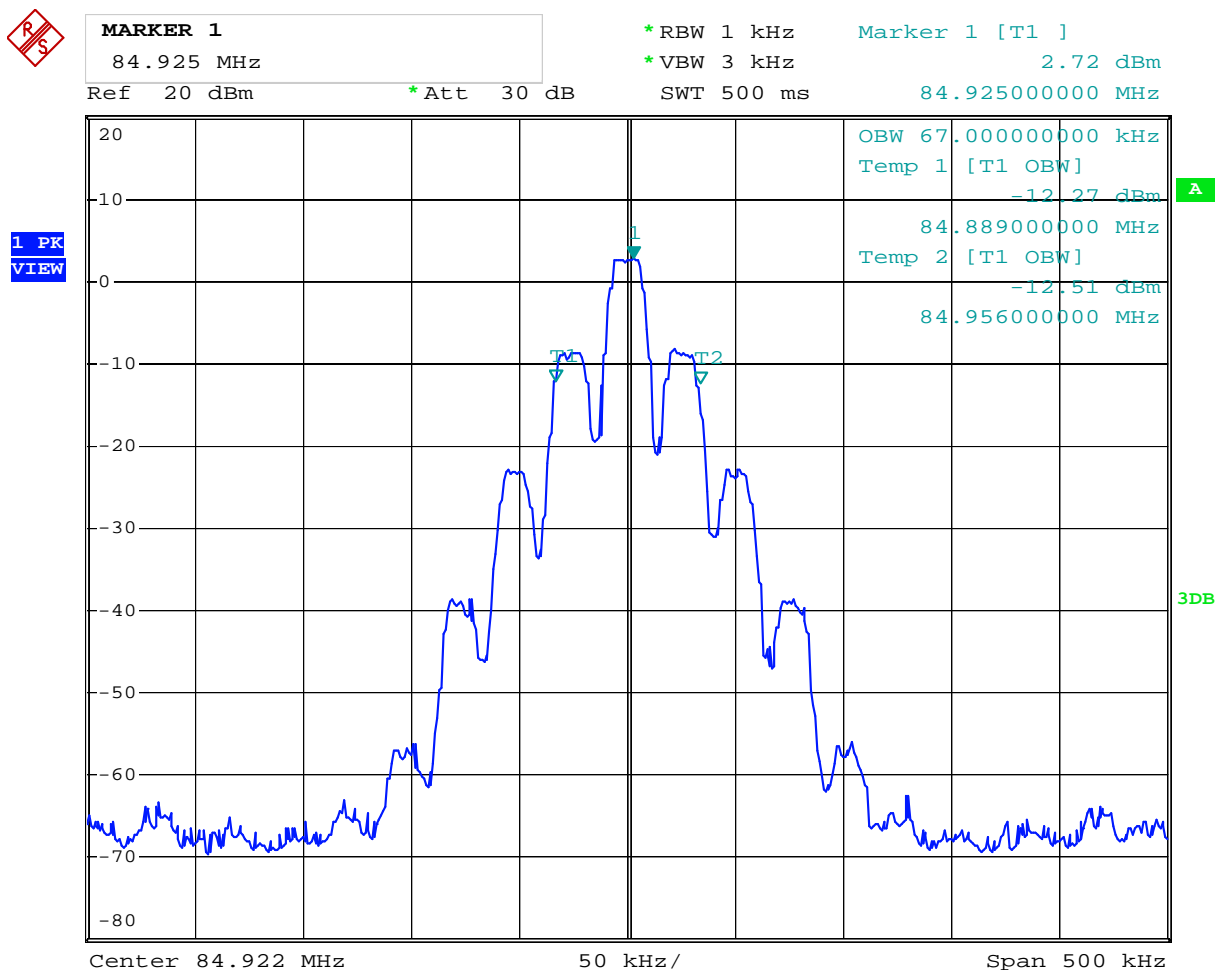

Date: 7.MAR.2014 10:17:47

The report refers only to the sample tested and does not apply to the bulk.
 This report is issued in confidence to the client and it will be strictly treated as such by the Shenzhen Timeway Technology Consulting Co., Ltd. It may not be reproduced in its entirety or in part and it may not be used for advertising. The client to whom the report is issued may, however, show or send it, or a certified copy thereof prepared by the Shenzhen Timeway Technology Consulting Co., Ltd. to his customer. Supplier or other persons directly concerned. Shenzhen Timeway Technology Consulting Co., Ltd. will not, without the consent of the client enter into any discussion of correspondence with any third party concerning the contents of the report.
 In the event of the improper use of the report, the Shenzhen Timeway Technology Consulting Co., Ltd. reserves the rights to withdraw it and to adopt any other remedies which may be appropriate.



Emission Mask: input with 10 kHz AF, 50% modulation + 16dB.

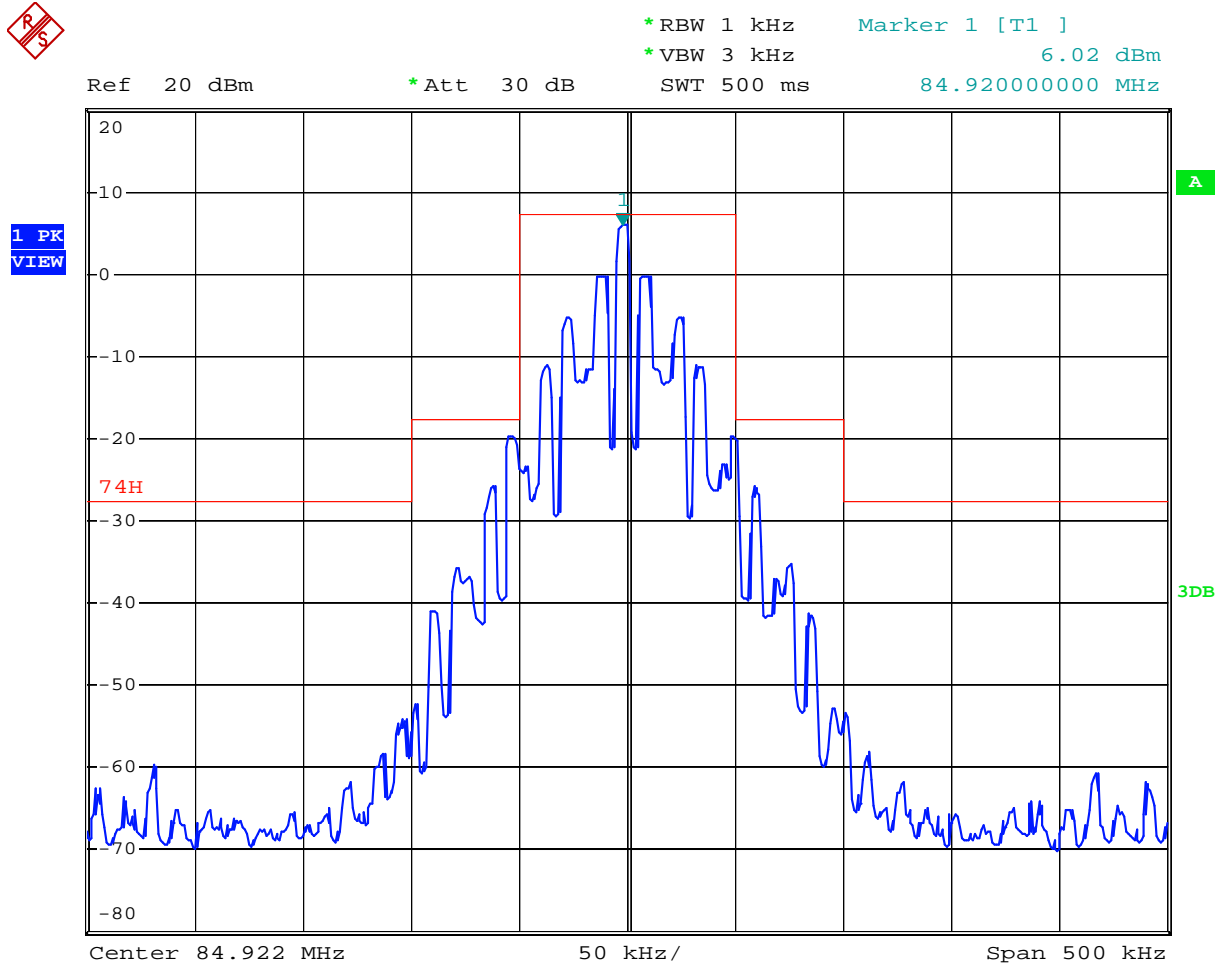

Date: 7.MAR.2014 10:11:22

The report refers only to the sample tested and does not apply to the bulk.
This report is issued in confidence to the client and it will be strictly treated as such by the Shenzhen Timeway Technology Consulting Co., Ltd. It may not be reproduced rather in its entirety or in part and it may not be used for advertising. The client to whom the report is issued may, however, show or send it, or a certified copy thereof prepared by the Shenzhen Timeway Technology Consulting Co., Ltd. to his customer. Supplier or other persons directly concerned. Shenzhen Timeway Technology Consulting Co., Ltd. will not, without the consent of the client enter into any discussion of correspondence with any third party concerning the contents of the report.
In the event of the improper use of the report, The Shenzhen Timeway Technology Consulting Co., Ltd reserves the rights to withdraw it and to adopt any other remedies which may be appropriate.



Emission Mask: input with 15 kHz AF, 50% modulation + 16dB.

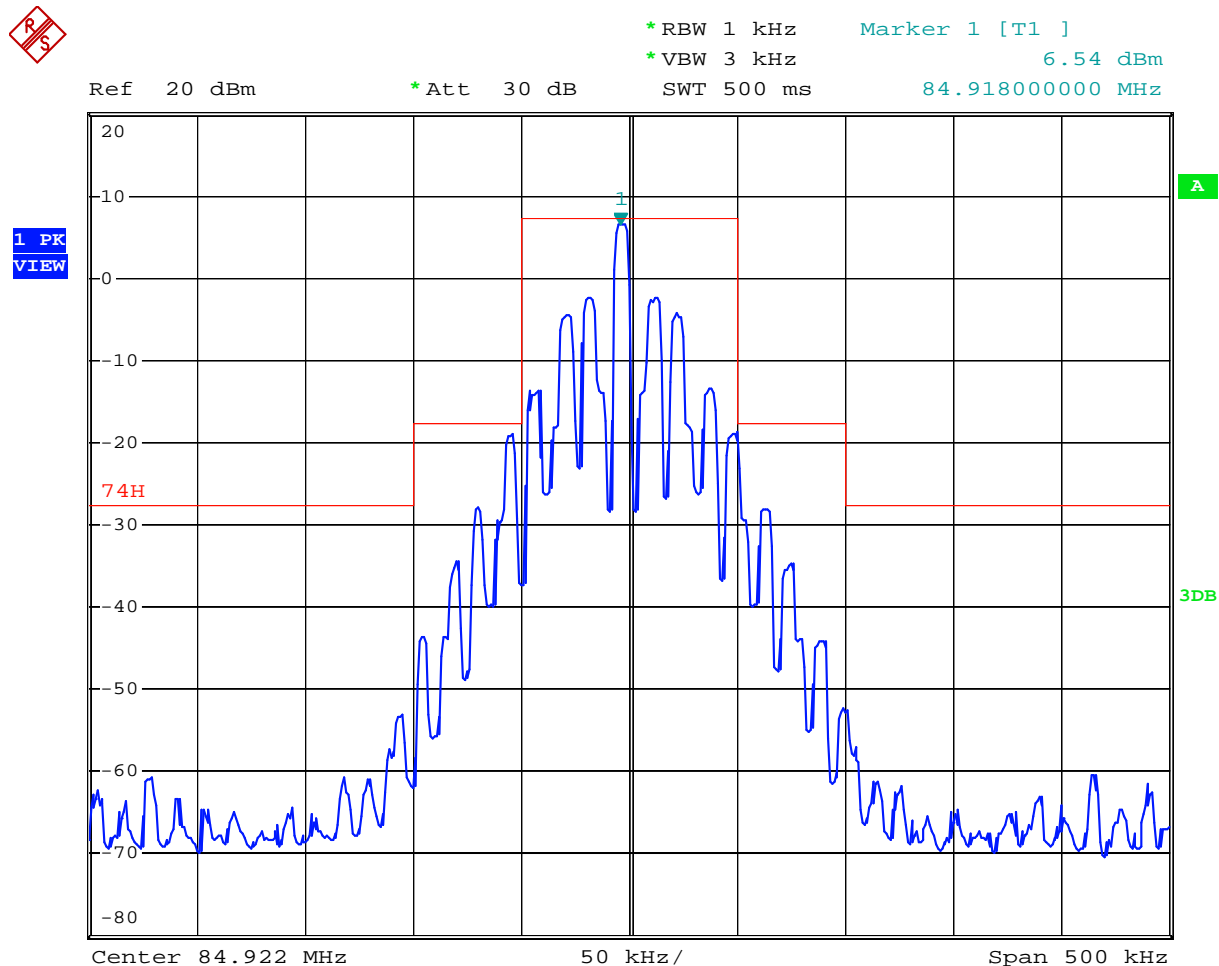

Date: 7.MAR.2014 10:14:34

Test results: The unit does meet the FCC requirements.

The report refers only to the sample tested and does not apply to the bulk.
This report is issued in confidence to the client and it will be strictly treated as such by the Shenzhen Timeway Technology Consulting Co.,Ltd. It may not be reproduced in its entirety or in part and it may not be used for advertising. The client to whom the report is issued may, however, show or send it, or a certified copy thereof prepared by the Shenzhen Timeway Technology Consulting Co.,Ltd to his customer. Supplier or other persons directly concerned. Shenzhen Timeway Technology Consulting Co.,Ltd will not, without the consent of the client enter into any discussion of correspondence with any third party concerning the contents of the report.
In the event of the improper use of the report. The Shenzhen Timeway Technology Consulting Co.,Ltd reserves the rights to withdraw it and to adopt any other remedies which may be appropriate.



5.2.3 Frequency Stability

Test Requirement: FCC CFR 47 Part 74.e) 4)

Test Method: FCC CFR 47 Part 2.1055

Requirements: +/-50 ppm

(e) For low power auxiliary stations operating in the bands allocated for TV broadcasting, the following technical requirements apply:

(4) The frequency tolerance of the transmitter shall be 0.005 percent.

Test Procedure:

Frequency stability versus Environmental Temperature

The equipment under test was connected to an external DC power supply and the RF output was connected to a frequency counter via feed through attenuators. The EUT was placed inside the temperature chamber. After the temperature stabilized for approximately 20 minutes, the frequency of the output signal was recorded from the counter.

Frequency Stability versus Input Voltage

At room temperature ($25 \pm 5^\circ\text{C}$), an external variable DC power supply was connected to the EUT. The frequency of the transmitter was measured for 115%, 100% and 85% of the nominal operating input voltage. For hand carried, battery powered equipment, reduce primary supply voltage to the battery operating end point which shall be specified by the manufacturer.

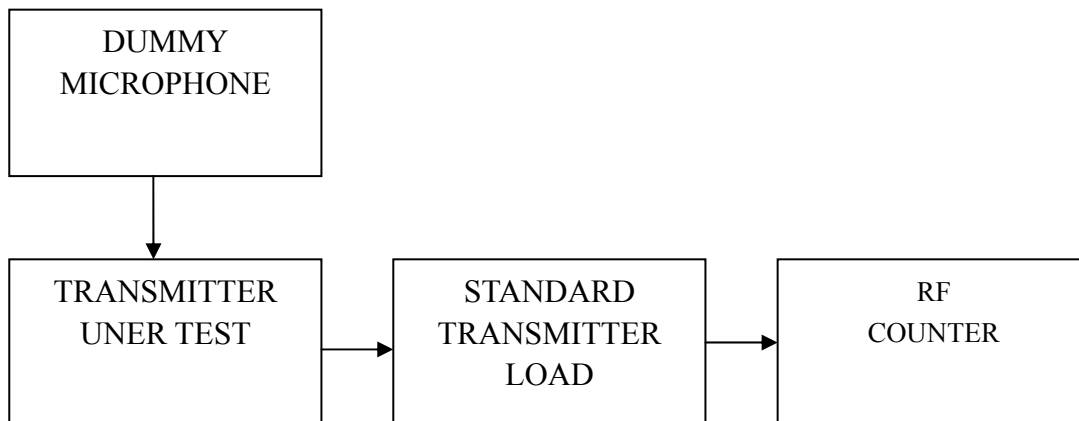

The report refers only to the sample tested and does not apply to the bulk.

This report is issued in confidence to the client and it will be strictly treated as such by the Shenzhen Timeway Technology Consulting Co., Ltd. It may not be reproduced in its entirety or in part and it may not be used for advertising. The client to whom the report is issued may, however, show or send it, or a certified copy thereof prepared by the Shenzhen Timeway Technology Consulting Co., Ltd. to his customer. Supplier or other persons directly concerned. Shenzhen Timeway Technology Consulting Co., Ltd. will not, without the consent of the client enter into any discussion of correspondence with any third party concerning the contents of the report.

In the event of the improper use of the report, The Shenzhen Timeway Technology Consulting Co., Ltd reserves the rights to withdraw it and to adopt any other remedies which may be appropriate.



Test Result:

Assigned Frequency: 84.922 MHz,		
Environment Temperature (°C)	Power Supplied (Vdc)	Frequency Measure with Time Elapsed Total emission within +/- 4.246 kHz
50	3	2.7
40	3	2.4
30	3	2.1
20	3	-1.7
10	3	-1.2
0	3	1.3
-10	3	2.0
-20	3	2.1
-30	3	0.8
Environment Temperature (°C)	Power Supplied (Vac)	Frequency Measure with Time Elapsed Total emission within Max +/- 4.246 kHz
25	2.55	-2.3
25	3.45	-1.8

The results: The unit does meet the FCC requirements.

The report refers only to the sample tested and does not apply to the bulk.
 This report is issued in confidence to the client and it will be strictly treated as such by the Shenzhen Timeway Technology Consulting Co., Ltd. It may not be reproduced in its entirety or in part and it may not be used for advertising. The client to whom the report is issued may, however, show or send it, or a certified copy thereof prepared by the Shenzhen Timeway Technology Consulting Co., Ltd. to his customer. Supplier or other persons directly concerned. Shenzhen Timeway Technology Consulting Co., Ltd. will not, without the consent of the client enter into any discussion of correspondence with any third party concerning the contents of the report.
 In the event of the improper use of the report, The Shenzhen Timeway Technology Consulting Co., Ltd reserves the rights to withdraw it and to adopt any other remedies which may be appropriate.



5.2.4 Modulation Characteristics

Test Requirement: FCC CFR 47 Part 74.e) 3)

Test Method: FCC CFR 47 Part 2.1047 & TIA/EIA 603 clause 2.2.3, 2.2.6

Requirements:

(e) For low power auxiliary stations operating in the bands allocated for TV broadcasting, the following technical requirements apply:

(3) Any form of modulation may be used. A maximum deviation of ± 75 kHz is permitted when frequency modulation is employed.

Test Procedure:

Audio Frequency Response

The RF output of the transceiver was connected to the input of FSP 30 with FM deviation module through sufficient attenuation so as not to overload the meter or distort the reading. An audio signal generator was connected to the audio input of microphone.

The audio signal input level was adjusted to obtain **20% of the maximum rated system deviation at 1 kHz**, and recorded as DEV_{REF} . With the audio signal generator level unchanged, set the generator frequency between 100 to 5000 Hz. The transmitter deviations (DEV_{FREQ}) were measured and the audio frequency response was calculated as $20 \log_{10} [DEV_{FREQ} / DEV_{REF}]$

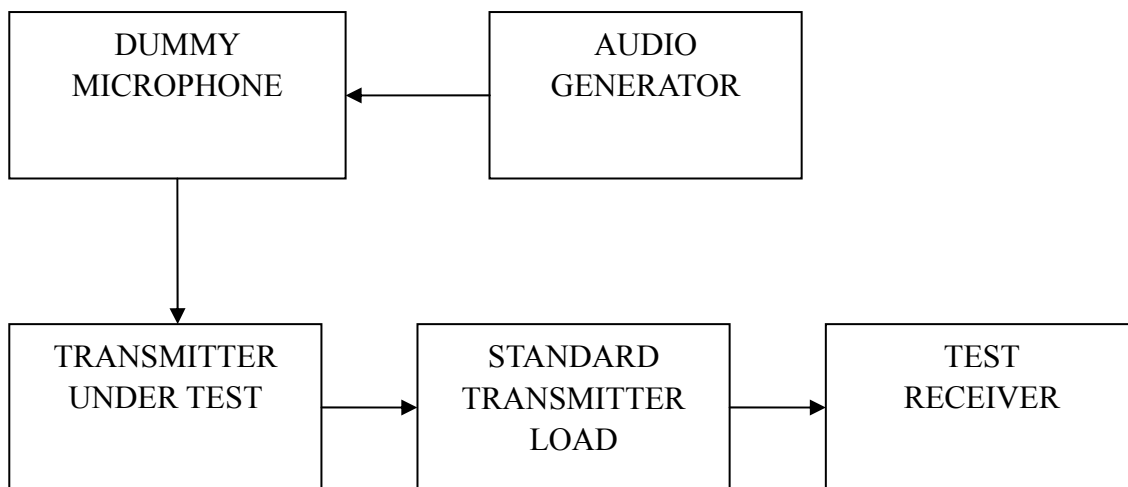

The report refers only to the sample tested and does not apply to the bulk.

This report is issued in confidence to the client and it will be strictly treated as such by the Shenzhen Timeway Technology Consulting Co., Ltd. It may not be reproduced in its entirety or in part and it may not be used for advertising. The client to whom the report is issued may, however, show or send it, or a certified copy thereof prepared by the Shenzhen Timeway Technology Consulting Co., Ltd. to his customer. Supplier or other persons directly concerned. Shenzhen Timeway Technology Consulting Co., Ltd. will not, without the consent of the client enter into any discussion of correspondence with any third party concerning the contents of the report.

In the event of the improper use of the report, the Shenzhen Timeway Technology Consulting Co., Ltd. reserves the rights to withdraw it and to adopt any other remedies which may be appropriate.

The plot(s) of Audio Frequency Response is presented hereinafter as reference.
0dB=10mV at 1kHz (20% of the maximum rated system deviation).

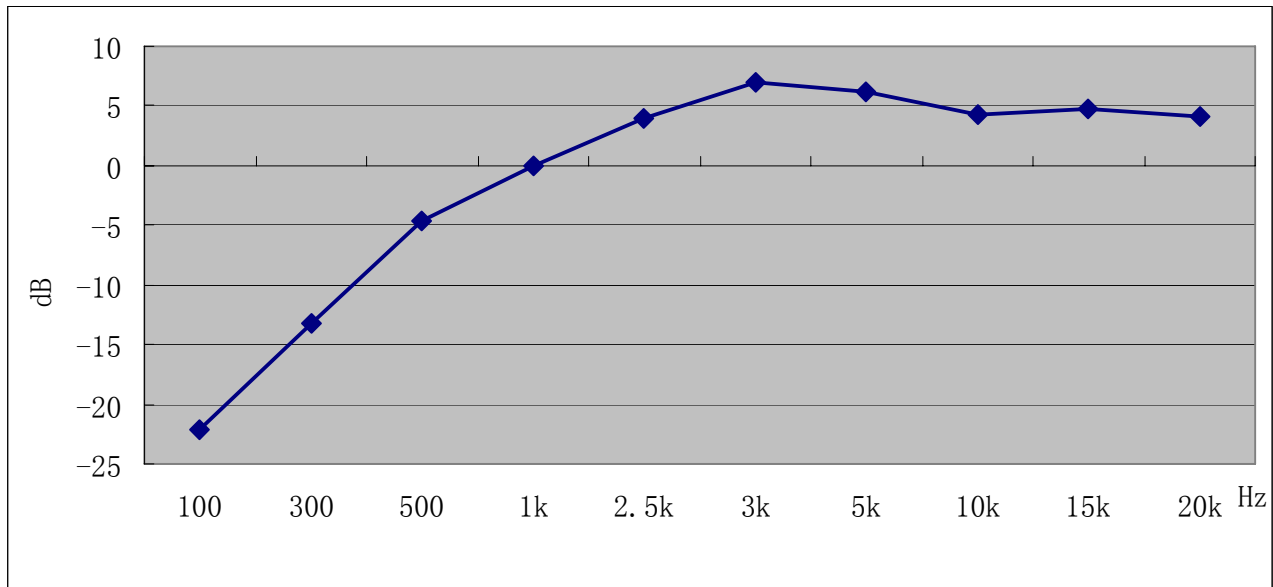

Modulation Limiting

- Adjust the transmitter per the manufacturer's procedure for full rated system deviation.
- Set the test receiver to measure peak positive deviation. Set the audio bandwidth for ≤ 0.25 Hz to $\geq 15,000$ Hz. Turn the de-emphasis function off.
- Apply a 1000 Hz modulating signal to the transmitter from the audio frequency generator, and adjust the level to obtain 60% of full rated system deviation.
- Increase the level from the audio frequency generator by 20 dB in one step (rise time between the 10% and 90% points shall be 0.1 second maximum).
- Measure both the instantaneous and steady-state deviation at and after the time of increasing the audio input level.
- With the level from the audio frequency generator held constant at the level obtained in step e), slowly vary the audio frequency from 100 to 15k Hz and observe the steady-state deviation. Record the maximum deviation.

The report refers only to the sample tested and does not apply to the bulk.

This report is issued in confidence to the client and it will be strictly treated as such by the Shenzhen Timeway Technology Consulting Co., Ltd. It may not be reproduced in its entirety or in part and it may not be used for advertising. The client to whom the report is issued may, however, show or send it, or a certified copy thereof prepared by the Shenzhen Timeway Technology Consulting Co., Ltd. to his customer. Supplier or other persons directly concerned. Shenzhen Timeway Technology Consulting Co., Ltd. will not, without the consent of the client enter into any discussion of correspondence with any third party concerning the contents of the report.

In the event of the improper use of the report, The Shenzhen Timeway Technology Consulting Co., Ltd reserves the rights to withdraw it and to adopt any other remedies which may be appropriate.

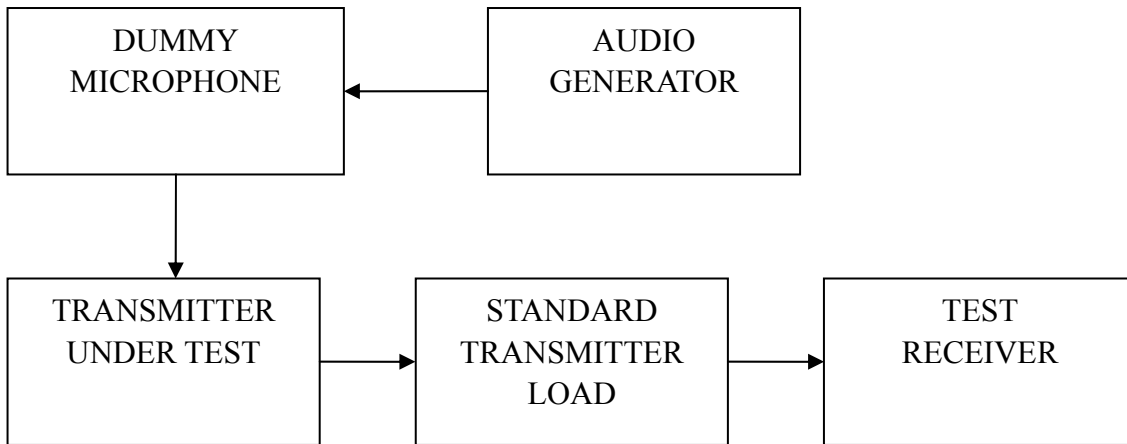

Test at five different modulating frequencies (100Hz ,300Hz, 500Hz, 1KHz, 2.5kHz,5kHz, 10kHz, 15kHz), the output level of the audio generator was varied up to 1V and the FM deviation level was recorded. Positive peak deviation

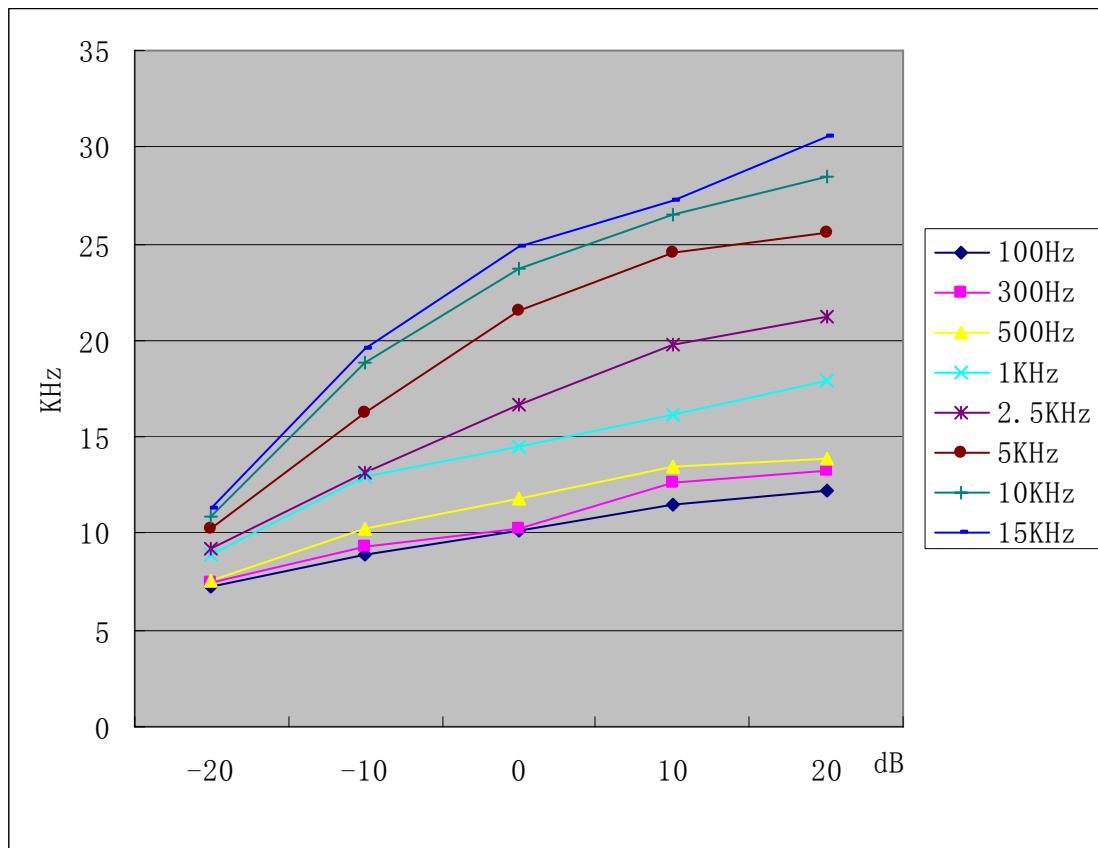

The report refers only to the sample tested and does not apply to the bulk.
 This report is issued in confidence to the client and it will be strictly treated as such by the Shenzhen Timeway Technology Consulting Co., Ltd. It may not be reproduced in its entirety or in part and it may not be used for advertising. The client to whom the report is issued may, however, show or send it, or a certified copy thereof prepared by the Shenzhen Timeway Technology Consulting Co., Ltd to his customer. Supplier or other persons directly concerned. Shenzhen Timeway Technology Consulting Co., Ltd will not, without the consent of the client enter into any discussion of correspondence with any third party concerning the contents of the report.
 In the event of the improper use of the report. The Shenzhen Timeway Technology Consulting Co., Ltd reserves the rights to withdraw it and to adopt any other remedies which may be appropriate.

6. Power Line Conducted Emission Test

6.1 Schematics of the test

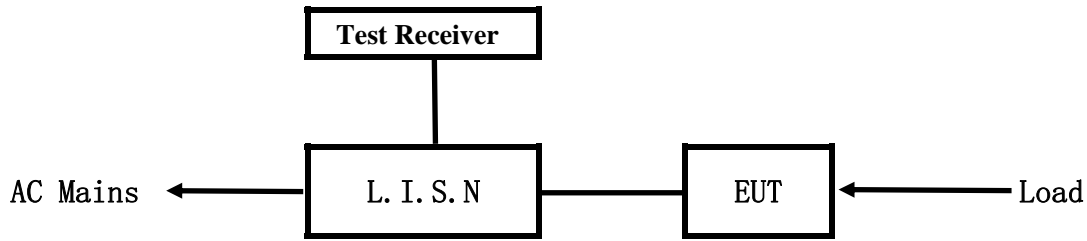

EUT: Equipment Under Test

6.2 Test Method and test Procedure

The EUT was tested according to ANSI C63.4-2003. The Frequency spectrum From 0.15MHz to 30MHz was investigated. The LISN used was 50ohm/50uH as specified by section 5.1 of ANSI C63.4 –2003.
 Test Voltage: 120V~, 60Hz
 Block diagram of Test setup

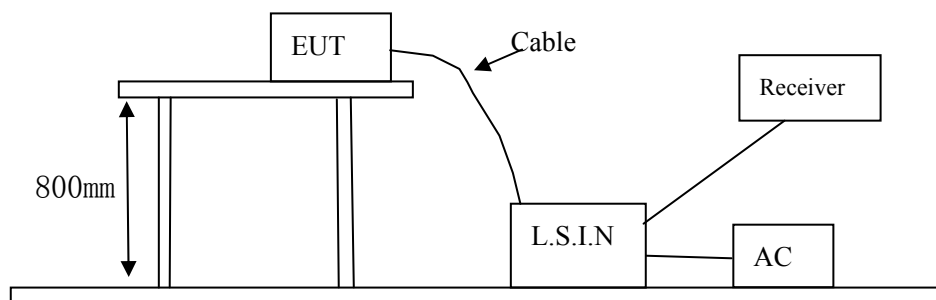

6.3 Configuration of The EUT

The EUT was configured according to ANSI C63.4-2003. All interface ports were connected to the appropriate peripherals. All peripherals and cables are listed below.

A. EUT

Device	Manufacturer	Model	FCC ID
Wireless Headphone	Hungtat Electronic Co., LTD	ONA14AA011	2ABV4-ONA14AA011

B. Internal Device

Device	Manufacturer	Model	FCC ID/DOC
N/A			

The report refers only to the sample tested and does not apply to the bulk.
 This report is issued in confidence to the client and it will be strictly treated as such by the Shenzhen Timeway Technology Consulting Co.,Ltd. It may not be reproduced rather in its entirety or in part and it may not be used for adverting. The client to whom the report is issued may, however, show or send it . or a certified copy there of prepared by the Shenzhen Timeway Technology Consulting co.,Ltd to his customer. Supplier or others persons directly concerned. Shenzhen Timeway Technology Consulting co.,Ltd will not, without the consent of the client enter into any discussion of correspondence with any third party concerning the contents of the report.
 In the event of the improper use of the report. The Shenzhen Timeway Technology Consulting co.,Ltd reserves the rights to withdraw it and to adopt any other remedies which may be appropriate.



C. Peripherals

Device	Manufacturer	Model	FCC ID/DOC	Cable
Power Supply	AWIN	AW-0301000UV	VOC	--

6.4 EUT Operating Condition

Operating condition is according to ANSI C63.4 -2003

A Setup the EUT and simulators as shown on follow

B Enable AF signal and confirm EUT active to normal condition

6.5 Power line conducted Emission Limit according to Paragraph 15.207

Frequency(MHz)	Class A Limits (dB μ V)		Class B Limits (dB μ V)	
	Quasi-peak Level	Average Level	Quasi-peak Level	Average Level
0.15 ~ 0.50	79.0	66.0	66.0~56.0*	56.0~46.0*
0.50 ~ 5.00	73.0	60.0	56.0	46.0
5.00 ~ 30.00	73.0	60.0	60.0	50.0

- Notes: 1. *Decreasing linearly with logarithm of frequency.
 2. The tighter limit shall apply at the transition frequencies

6.6 Test Results

The frequency spectrum from 0.15MHz to 30MHz was investigated. All reading are quasi-peak values with a resolution bandwidth of 9kHz.



A: Conducted Emission on Live Terminal (150kHz to 30MHz)

EUT Operating Environment

Temperature: 26°C Humidity: 65%RH Atmospheric Pressure: 101 kPa

EUT set Condition: Keep Transmitting

Equipment Level: Class B

Results: PASS

Please refer to following diagram for individual

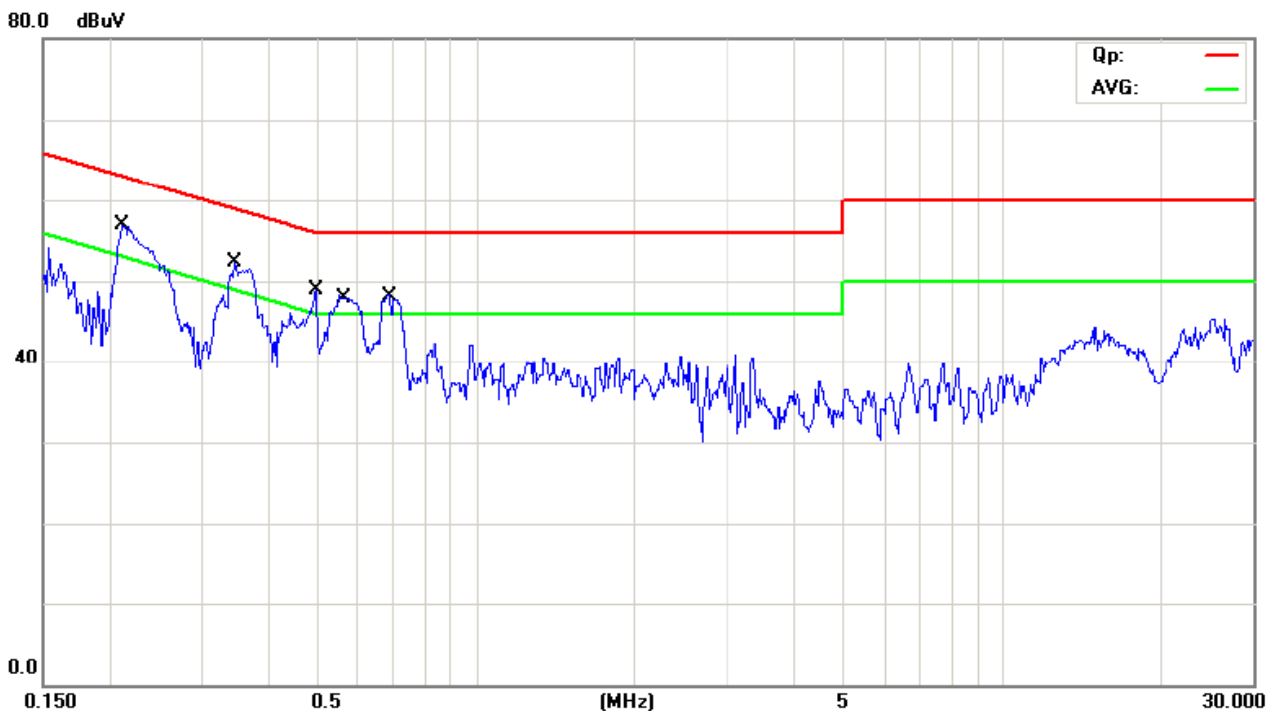

No.	Mk.	Freq. MHz	Reading Level dBuV	Correct Factor dB	Measure- ment dBuV	Limit dBuV	Over dB	Detector
1		0.2137	42.15	11.07	53.22	63.06	-9.84	QP
2	*	0.2137	32.43	11.07	43.50	53.06	-9.56	AVG
3		0.3450	36.58	11.21	47.79	59.08	-11.29	QP
4		0.3450	20.43	11.21	31.64	49.08	-17.44	AVG
5		0.5023	34.52	11.37	45.89	56.00	-10.11	QP
6		0.5023	19.69	11.37	31.06	46.00	-14.94	AVG
7		0.5656	33.48	11.44	44.92	56.00	-11.08	QP
8		0.5656	17.64	11.44	29.08	46.00	-16.92	AVG
9		0.6815	32.08	11.56	43.64	56.00	-12.36	QP
10		0.6815	23.25	11.56	34.81	46.00	-11.19	AVG

The report refers only to the sample tested and does not apply to the bulk.
 This report is issued in confidence to the client and it will be strictly treated as such by the Shenzhen Timeway Technology Consulting Co., Ltd. It may not be reproduced rather in its entirety or in part and it may not be used for advertising. The client to whom the report is issued may, however, show or send it, or a certified copy thereof prepared by the Shenzhen Timeway Technology Consulting Co., Ltd to his customer. Supplier or others persons directly concerned. Shenzhen Timeway Technology Consulting Co., Ltd will not, without the consent of the client enter into any discussion of correspondence with any third party concerning the contents of the report.
 In the event of the improper use of the report. The Shenzhen Timeway Technology Consulting Co., Ltd reserves the rights to withdraw it and to adopt any other remedies which may be appropriate.



B: Conducted Emission on Neutral Terminal (150kHz to 30MHz)

EUT Operating Environment

Temperature: 26°C Humidity: 65%RH Atmospheric Pressure: 101 kPa

EUT set Condition: Keep Transmitting

Equipment Level: Class B

Results: Pass

Please refer to following diagram for individual

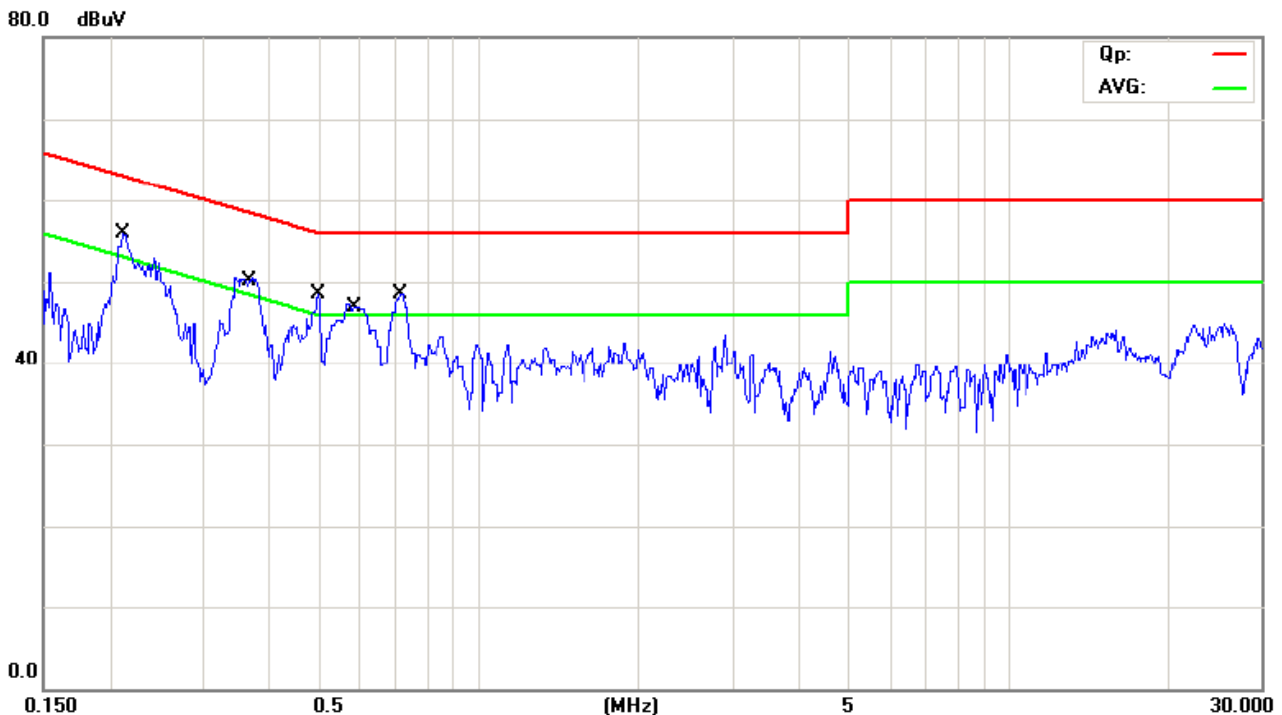

No.	Mk.	Freq. MHz	Reading Level dBuV	Correct Factor dB	Measure- ment dBuV	Limit dBuV	Over dB	Detector
1		0.2147	36.58	11.07	47.65	63.02	-15.37	QP
2	*	0.2147	33.40	11.07	44.47	53.02	-8.55	AVG
3		0.3658	33.37	11.23	44.60	58.60	-14.00	QP
4		0.3658	18.69	11.23	29.92	48.60	-18.68	AVG
5		0.5002	33.17	11.37	44.54	56.00	-11.46	QP
6		0.5002	17.69	11.37	29.06	46.00	-16.94	AVG
7		0.5788	30.36	11.45	41.81	56.00	-14.19	QP
8		0.5788	18.41	11.45	29.86	46.00	-16.14	AVG
9		0.7084	31.48	11.59	43.07	56.00	-12.93	QP
10		0.7084	19.23	11.59	30.82	46.00	-15.18	AVG

The report refers only to the sample tested and does not apply to the bulk.
This report is issued in confidence to the client and it will be strictly treated as such by the Shenzhen Timeway Technology Consulting Co., Ltd. It may not be reproduced rather in its entirety or in part and it may not be used for advertising. The client to whom the report is issued may, however, show or send it, or a certified copy thereof prepared by the Shenzhen Timeway Technology Consulting Co., Ltd to his customer. Supplier or others persons directly concerned. Shenzhen Timeway Technology Consulting Co., Ltd will not, without the consent of the client enter into any discussion of correspondence with any third party concerning the contents of the report.
In the event of the improper use of the report. The Shenzhen Timeway Technology Consulting Co., Ltd reserves the rights to withdraw it and to adopt any other remedies which may be appropriate.

7.0 FCC ID Label

FCC ID: 2ABV4-ONA14AA011

The label must not be a stick-on paper label. The label on these products must be permanently affixed to the product and readily visible at the time of purchase and must last the expected lifetime of the equipment not be readily detachable.

Mark Location:

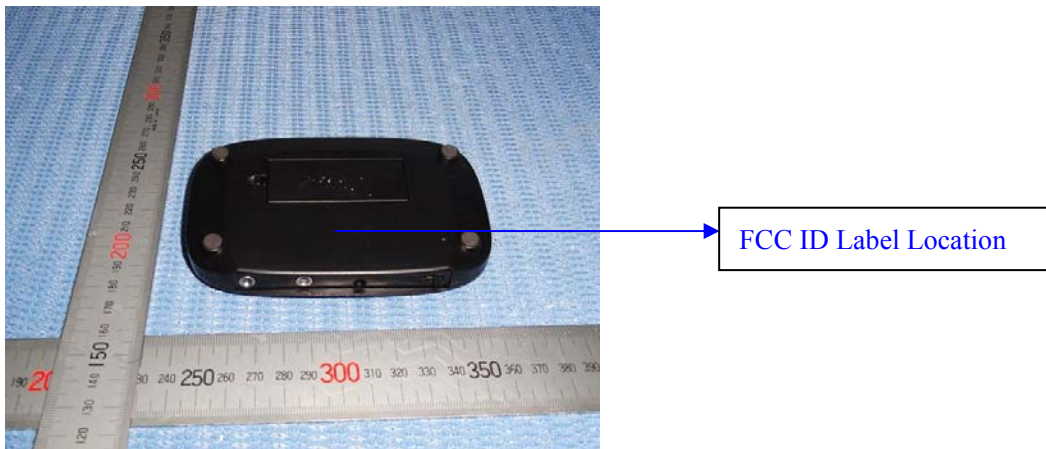

The report refers only to the sample tested and does not apply to the bulk.

This report is issued in confidence to the client and it will be strictly treated as such by the Shenzhen Timeway Technology Consulting Co., Ltd. It may not be reproduced in its entirety or in part and it may not be used for advertising. The client to whom the report is issued may, however, show or send it, or a certified copy thereof prepared by the Shenzhen Timeway Technology Consulting Co., Ltd. to his customer, supplier or other persons directly concerned. Shenzhen Timeway Technology Consulting Co., Ltd. will not, without the consent of the client, enter into any discussion of correspondence with any third party concerning the contents of the report.

In the event of the improper use of the report, the Shenzhen Timeway Technology Consulting Co., Ltd. reserves the rights to withdraw it and to adopt any other remedies which may be appropriate.

8.0 Photo of testing

8.1 Conducted Emissions test view



8.2 Radiated emission test view



The report refers only to the sample tested and does not apply to the bulk.

This report is issued in confidence to the client and it will be strictly treated as such by the Shenzhen Timeway Technology Consulting Co., Ltd. It may not be reproduced rather in its entirety or in part and it may not be used for advertising. The client to whom the report is issued may, however, show or send it, or a certified copy thereof prepared by the Shenzhen Timeway Technology Consulting Co., Ltd. to his customer, supplier or other persons directly concerned. Shenzhen Timeway Technology Consulting Co., Ltd. will not, without the consent of the client, enter into any discussion of correspondence with any third party concerning the contents of the report.

In the event of the improper use of the report, the Shenzhen Timeway Technology Consulting Co., Ltd. reserves the rights to withdraw it and to adopt any other remedies which may be appropriate.

7.3

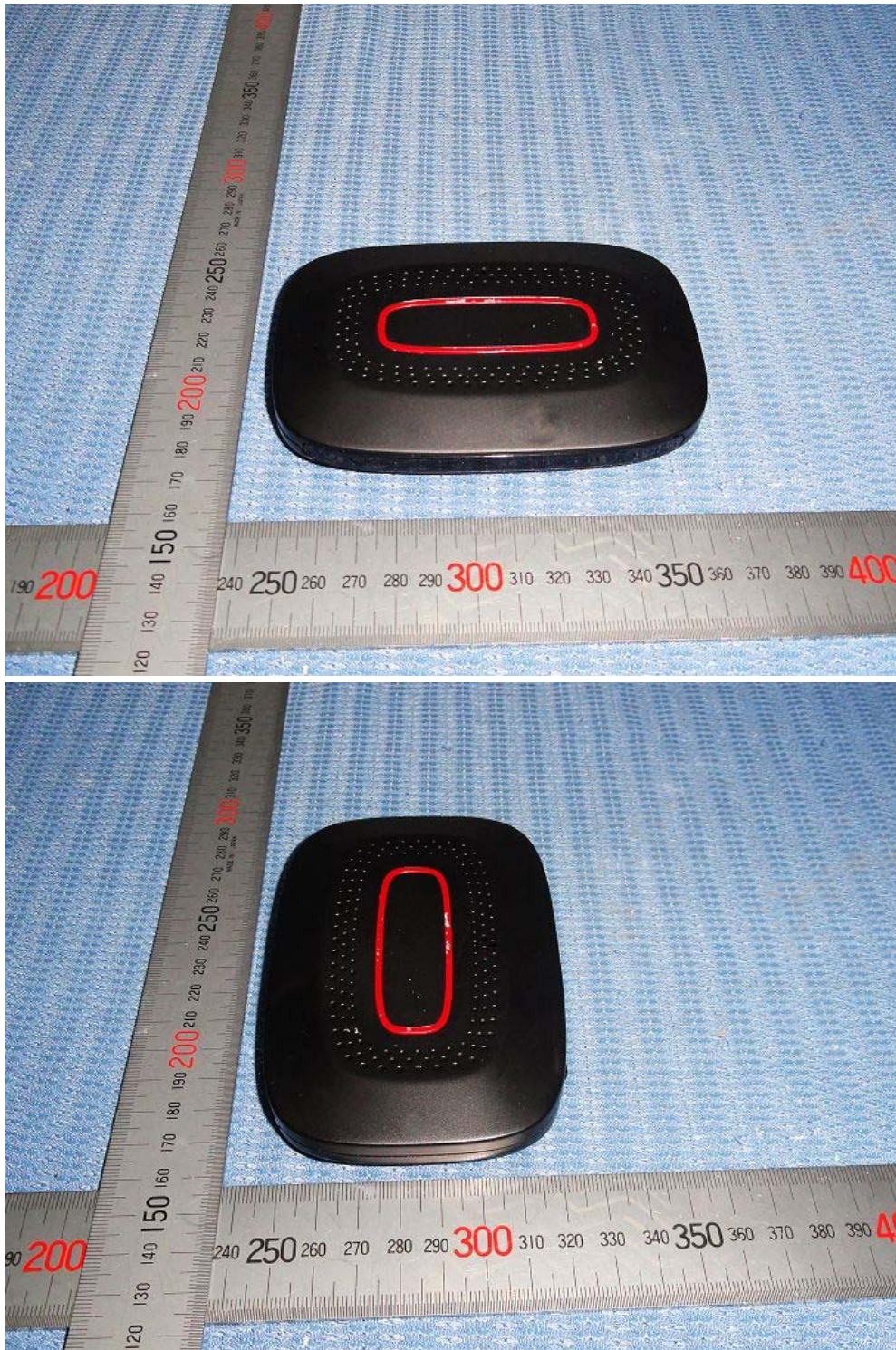

The report refers only to the sample tested and does not apply to the bulk.
This report is issued in confidence to the client and it will be strictly treated as such by the Shenzhen Timeway Technology Consulting Co., Ltd. It may not be reproduced rather in its entirety or in part and it may not be used for advertising. The client to whom the report is issued may, however, show or send it, or a certified copy thereof prepared by the Shenzhen Timeway Technology Consulting Co., Ltd. to his customer, supplier or other persons directly concerned. Shenzhen Timeway Technology Consulting Co., Ltd. will not, without the consent of the client enter into any discussion of correspondence with any third party concerning the contents of the report.
In the event of the improper use of the report, the Shenzhen Timeway Technology Consulting Co., Ltd. reserves the rights to withdraw it and to adopt any other remedies which may be appropriate.



The report refers only to the sample tested and does not apply to the bulk.
This report is issued in confidence to the client and it will be strictly treated as such by the Shenzhen Timeway Technology Consulting Co., Ltd. It may not be reproduced in its entirety or in part and it may not be used for advertising. The client to whom the report is issued may, however, show or send it, or a certified copy thereof prepared by the Shenzhen Timeway Technology Consulting Co., Ltd. to his customer, supplier or other persons directly concerned. Shenzhen Timeway Technology Consulting Co., Ltd. will not, without the consent of the client, enter into any discussion of correspondence with any third party concerning the contents of the report.
In the event of the improper use of the report, the Shenzhen Timeway Technology Consulting Co., Ltd. reserves the rights to withdraw it and to adopt any other remedies which may be appropriate.



The report refers only to the sample tested and does not apply to the bulk.

This report is issued in confidence to the client and it will be strictly treated as such by the Shenzhen Timeway Technology Consulting Co., Ltd. It may not be reproduced in its entirety or in part and it may not be used for advertising. The client to whom the report is issued may, however, show or send it, or a certified copy thereof prepared by the Shenzhen Timeway Technology Consulting Co., Ltd. to his customer, supplier or other persons directly concerned. Shenzhen Timeway Technology Consulting Co., Ltd. will not, without the consent of the client, enter into any discussion of correspondence with any third party concerning the contents of the report.

In the event of the improper use of the report, the Shenzhen Timeway Technology Consulting Co., Ltd. reserves the rights to withdraw it and to adopt any other remedies which may be appropriate.

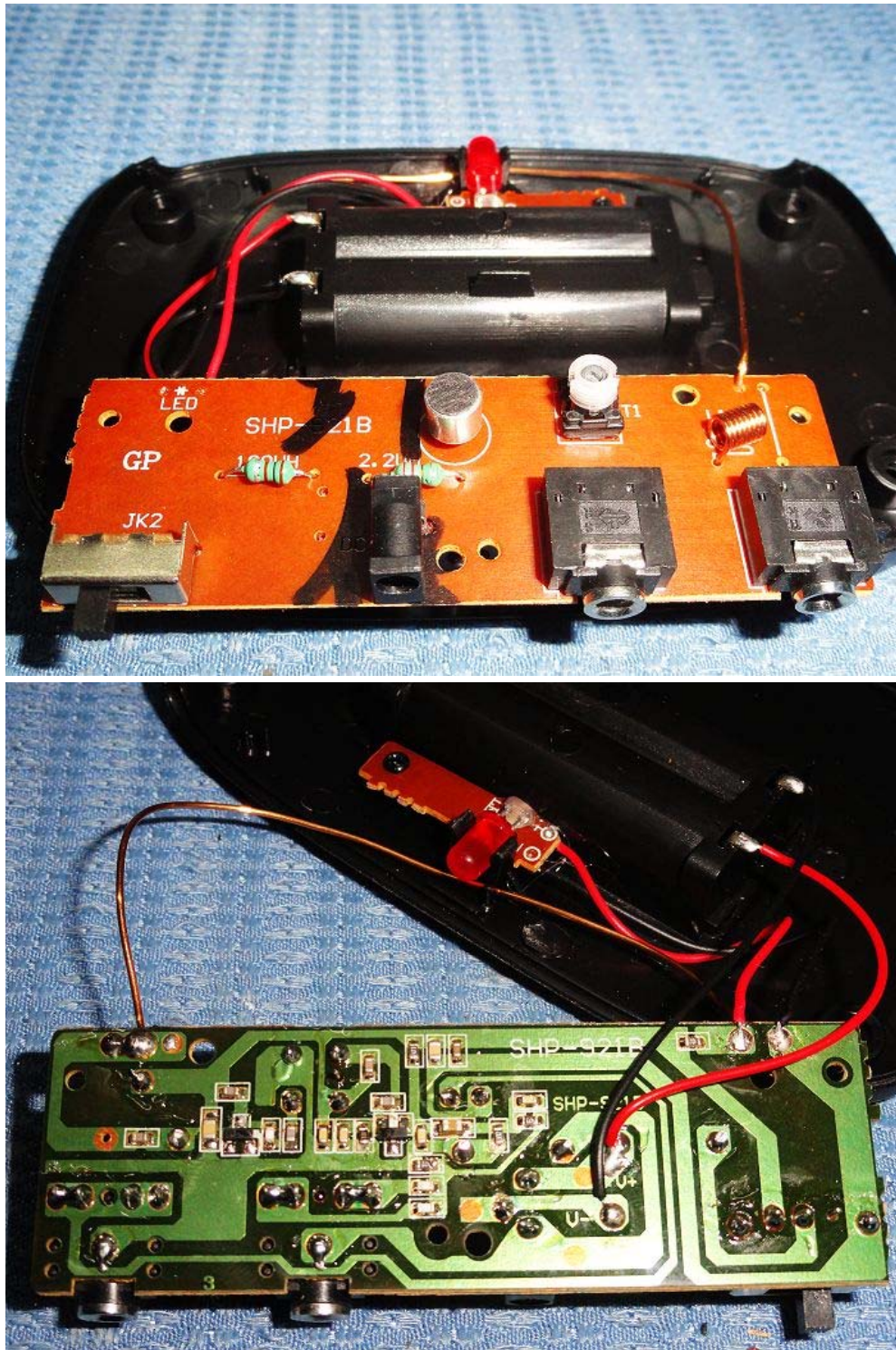

The report refers only to the sample tested and does not apply to the bulk.

This report is issued in confidence to the client and it will be strictly treated as such by the Shenzhen Timeway Technology Consulting Co., Ltd. It may not be reproduced in its entirety or in part and it may not be used for advertising. The client to whom the report is issued may, however, show or send it, or a certified copy thereof prepared by the Shenzhen Timeway Technology Consulting Co., Ltd. to his customer, supplier or other persons directly concerned. Shenzhen Timeway Technology Consulting Co., Ltd. will not, without the consent of the client, enter into any discussion of correspondence with any third party concerning the contents of the report.

In the event of the improper use of the report, the Shenzhen Timeway Technology Consulting Co., Ltd. reserves the rights to withdraw it and to adopt any other remedies which may be appropriate.

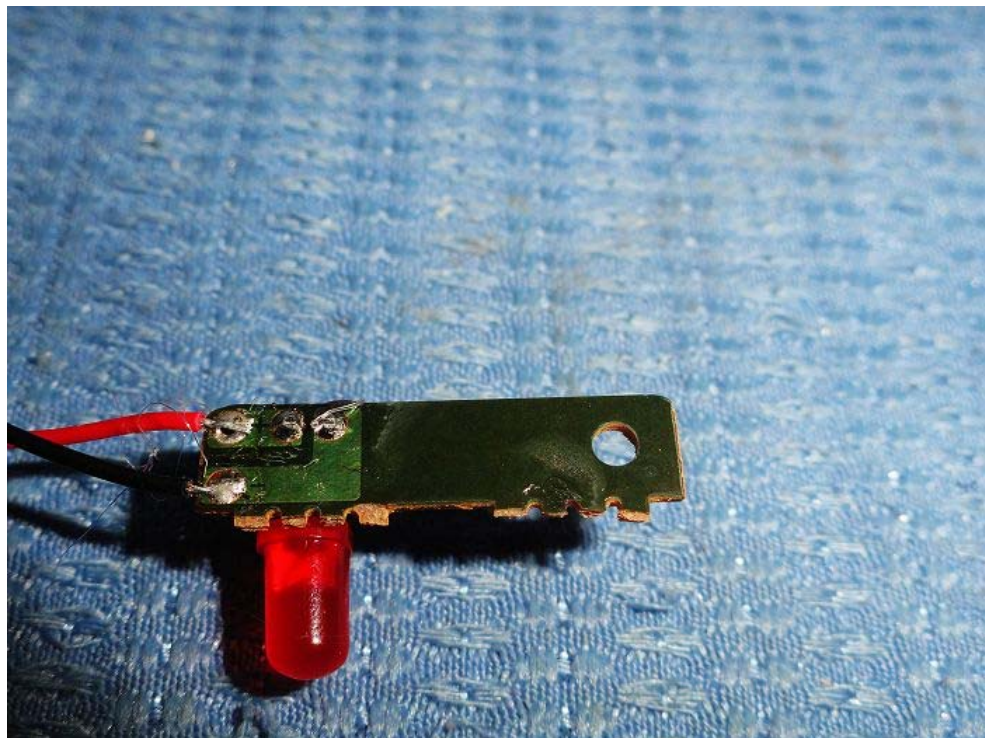
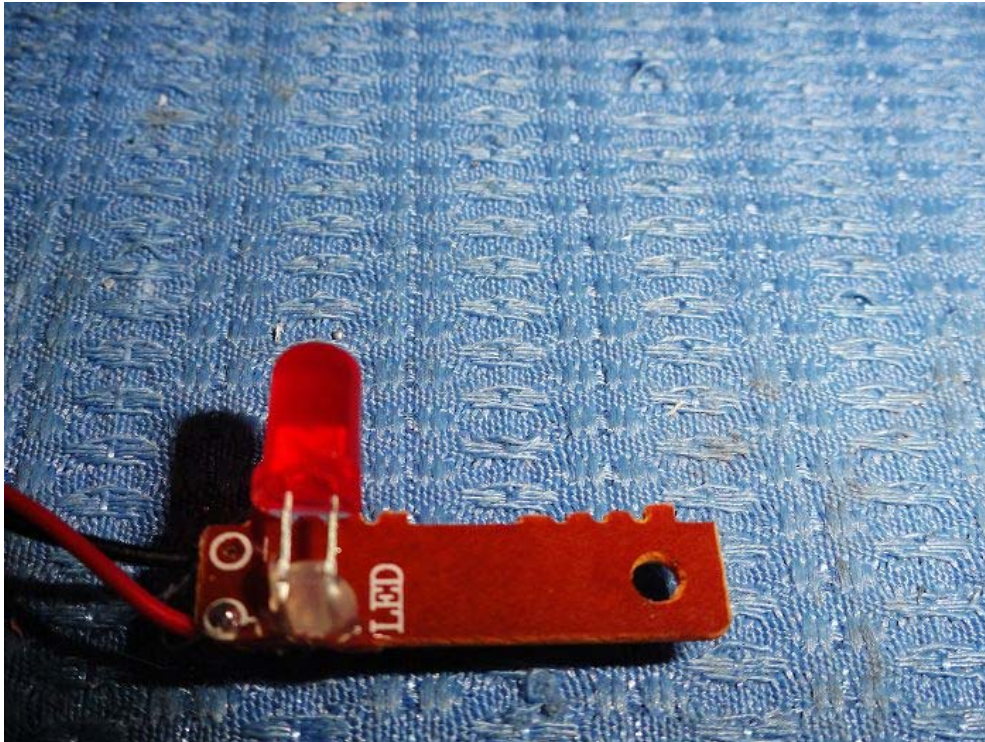

End of the report

The report refers only to the sample tested and does not apply to the bulk.

This report is issued in confidence to the client and it will be strictly treated as such by the Shenzhen Timeway Technology Consulting Co., Ltd. It may not be reproduced in its entirety or in part and it may not be used for advertising. The client to whom the report is issued may, however, show or send it, or a certified copy thereof prepared by the Shenzhen Timeway Technology Consulting Co., Ltd. to his customer, supplier or other persons directly concerned. Shenzhen Timeway Technology Consulting Co., Ltd. will not, without the consent of the client, enter into any discussion of correspondence with any third party concerning the contents of the report.

In the event of the improper use of the report, the Shenzhen Timeway Technology Consulting Co., Ltd. reserves the rights to withdraw it and to adopt any other remedies which may be appropriate.