

亞 驪 企 業 股 份 有 限 公 司

ARISTOTLE ENTERPRISES

承 認 申 請 書

ROHS COMPLIANCE

客戶名稱: 易通展科技股份有限公司
Customer
廠商料號: RFA-25-T173-B32-C603
Part No.
品名: Dual Band,白色天線
Description
圖號: RFA-25-T173-B32-C603.DWG
Drawing No.
客戶料號:
Drawing No.

出廠簽章:

檢 查 TEST BY	核 對 CHECK BY	承 認 APPROVE BY
方美鑾	劉蘇華	廖煥文

承認簽章:

檢 查 TEST BY	核 對 CHECK BY	承 認 APPROVE BY

地址:新北市中和區莒光路 63 號 8 樓

電話:02-2225-8209

傳真:02-2225-7523

NO.	NAME	FINSH	MAT'L	Q'TY	MEMO
1.	Bottom Housing	White	ABS	1	
2.	Top Housing	White	ABS	1	
3.	Base	White	ABS	1	
4.	Hinge	White	ABS	1	
5.	Connector	White	BRASS	1	RP SMA PLUG

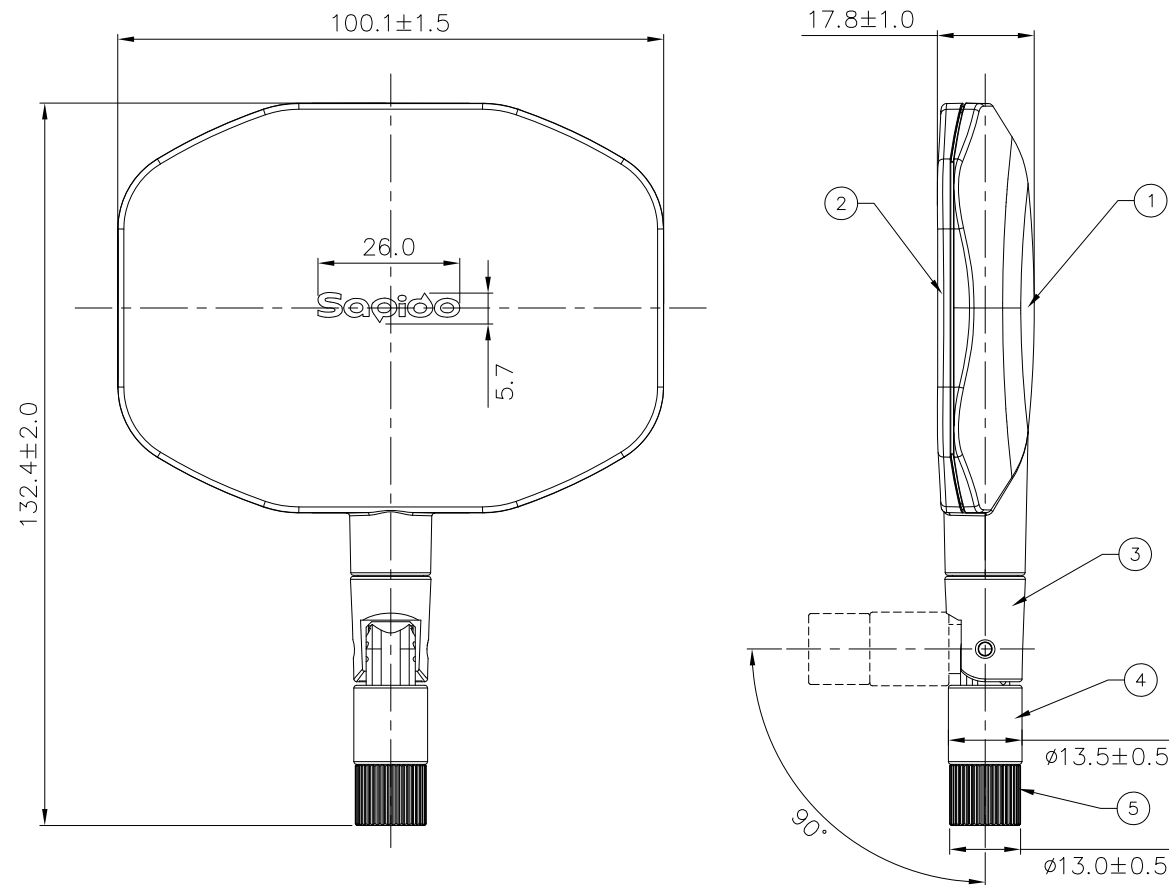

PROJECTION	TOLERANCE UNLESS OTHERWISE SPECIFIED	
	LINER	ANGLE
UNITS	.X ±0.10	X° ±0.5°
MM	.XX ±0.05	
	.XXX ±0.01	

亞驪企業股份有限公司 ARISTOTLE ENTERPRISES INC.	
TITLE	
RFA-25-T173-B32-C603	
DWG NO.	
RFA-25-T173-B32-C603	

3.				REV.	A	APPD.		
2.				SHEET	1/1	CHKD.		
1.				SIZE	A4	DESIGN		
REV.	ECN.	NAME	DATE	A4	1:1	DRAW	Vince Tsai	013/09/05

RFA-25-T173-B32-C603

Electrical Specifications

Frequency range	2400-2500 MHz	4900-5875MHz
Gain	5dBi	7dBi
VSWR	2.0:1 Max.	2.0:1 Max.
Polarization	Linear, vertical	
Impedance	50 Ω	
Connector	RP SMA PLUG	

Environmental & Mechanical Characteristics

Temperature	-10°C to +55°C
Humidity	95% @55°C



VSWR

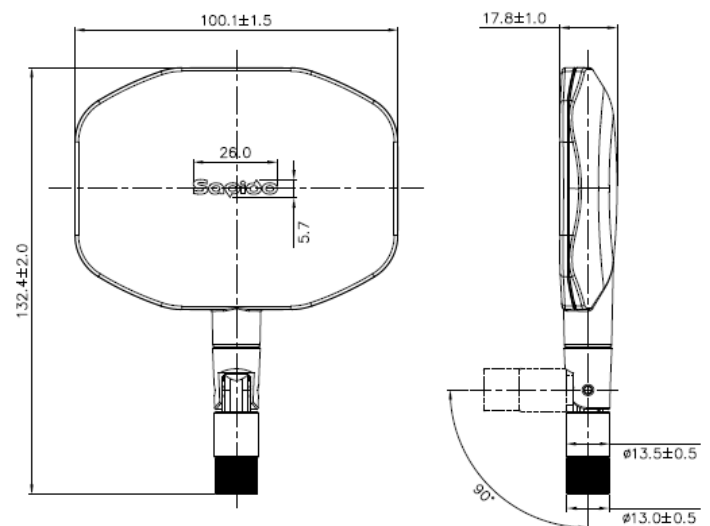
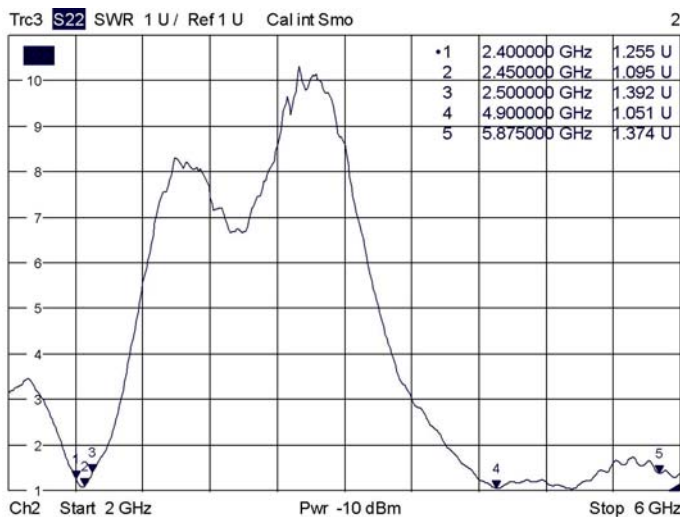

Radiation Pattern

— 2400(MHz)
— 2450(MHz)
— 2500(MHz)

H-plane
Co-polar.

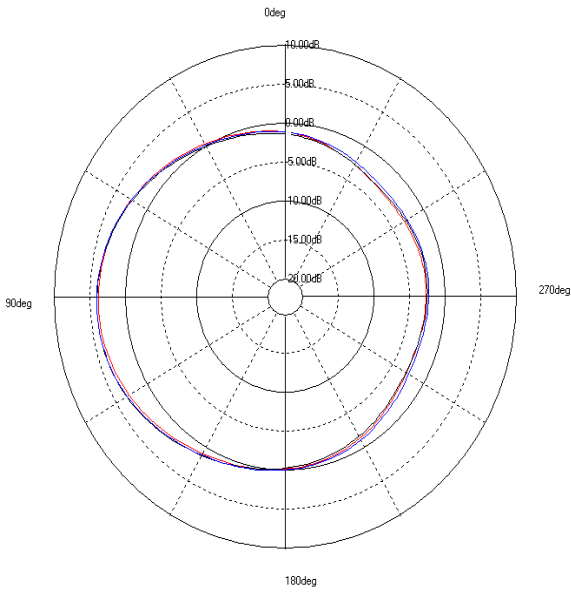

V-plane
Co-polar.

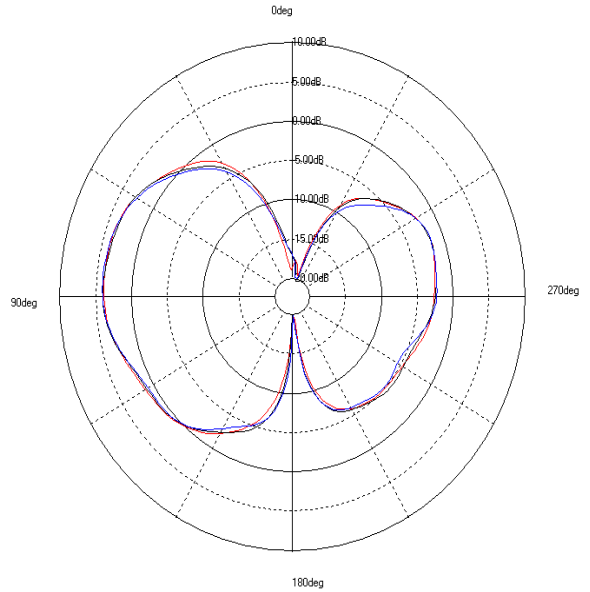

— 4900.00(MHz)
— 5150.00(MHz)
— 5350.00(MHz)
— 5600.00(MHz)
— 5725.00(MHz)
— 5875.00(MHz)

