

TABLE OF CONTENTS

Page

1. TEST SUMMARY.....	3
1.1. TEST STANDARDS.....	3
1.2. REPORT VERSION.....	3
1.3. TEST DESCRIPTION.....	4
1.4. TEST FACILITY.....	5
1.5. MEASUREMENT UNCERTAINTY.....	6
1.6. ENVIRONMENTAL CONDITIONS.....	6
2. GENERAL INFORMATION.....	7
2.1. CLIENT INFORMATION.....	7
2.2. GENERAL DESCRIPTION OF EUT.....	7
2.3. TEST MODE.....	7
2.4. MEASUREMENT INSTRUMENTS LIST.....	8
2.5. TEST SOFTWARE.....	8
3. TEST ITEM AND RESULTS.....	9
3.1. ANTENNA REQUIREMENT.....	9
3.2. CONDUCTED EMISSION.....	10
3.3. OCCUPIED BANDWIDTH.....	11
3.4. DEACTIVATION TIME.....	13
3.5. SPURIOUS EMISSION (RADIATED).....	15
4. EUT TEST PHOTOS.....	21
5. PHOTOGRAPHS OF EUT CONSTRUCTIONAL.....	22

1. TEST SUMMARY

1.1. Test Standards

The tests were performed according to following standards:

FCC Rules Part 15.231: Periodic operation in the band 40.66–40.70 MHz and above 70 MHz.

ANSI C63.10-2013: American National Standard for Testing Unlicensed Wireless Devices.

1.2. Report version

Revised No.	Date of issue	Description
01	Aug. 25, 2020	Original

1.3. Test Description

FCC Rules Part 15.231			
Test Item	Standard Section	Result	Test Engineer
	FCC		
Antenna requirement	15.203	Pass	Rory Huang
Conducted Emissions	15.207	N/A	N/A
Radiated Spurious Emissions	15.205/15.209(a)/15.231(b)/15.35(c)	Pass	Rory Huang
Deactivation Time	15.231(a)(1)	Pass	Rory Huang
Duty Cycle	15.231	Pass	Rory Huang
Occupied Bandwidth	15.231(c)	Pass	Rory Huang

Note: 1. The measurement uncertainty is not included in the test result.

2.N/A: means this test item is not applicable

1.4. Test Facility

Address of the report laboratory

KSIGN(Guangdong) Testing Co., Ltd.

West Side of 1/F., Building C, Zone A, Fuyuan New Factory, Jiujiu Industrial Park, Minzhu, Shatou, Shajing, Bao'an District, Shenzhen, Guangdong, People's Republic of China

Laboratory accreditation

The test facility is recognized, certified, or accredited by the following organizations:

CNAS-Lab Code: L13261

KSIGN(Guangdong) Testing Co., Ltd. has been assessed and proved to be in Compliance with CNAS-CL01 Accreditation Criteria for Testing and Calibration Laboratories (identical to ISO/IEC17025: 2017 General Requirements) for the Competence of Testing and Calibration Laboratories.

A2LA-Lab Cert. No.: 5457.01

KSIGN(Guangdong) Testing Co., Ltd. EMC Laboratory has been accredited by A2LA for technical competence in the field of electrical testing, and proved to be in compliance with ISO/IEC 17025:2017 General Requirements for the Competence of Testing and Calibration Laboratories and any additional program requirements in the identified field of testing.

IC Registration No.: CN0096

The 3m alternate test site of KSIGN(Guangdong) Testing Co., Ltd. EMC Laboratory has been registered by Certification and Engineer Bureau of Industry Canada for the performance of with Registration NO.: CN0096

FCC-Registration No.: CN1272

KSIGN(Guangdong) Testing Co., Ltd. EMC Laboratory has been registered and fully described in a report filed with the (FCC) Federal Communications Commission. The acceptance letter from the FCC is maintained in our files.

1.5. Measurement Uncertainty

The data and results referenced in this document are true and accurate. The reader is cautioned that there may be errors within the calibration limits of the equipment and facilities. The measurement uncertainty was calculated for all measurements listed in this test report acc. to TR-100028-01” Electromagnetic compatibility and Radio spectrum Matters (ERM);Uncertainties in the measurement of mobile radio equipment characteristics; Part 1” and TR-100028-02 “Electromagnetic compatibility and Radio spectrum Matters (ERM);Uncertainties in the measurement of mobile radio equipment characteristics; Part 2 “ and is documented in the KSIGN(Guangdong) Testing Co., Ltd. system acc. to DIN EN ISO/IEC 17025. Furthermore, component and process variability of devices similar to that tested may result in additional deviation. The manufacturer has the sole responsibility of continued compliance of the device. Below is the best measurement capability for KSIGN(Guangdong) Testing Co., Ltd.

Test Items	Measurement Uncertainty	Notes
Transmitter power conducted	0.42 dB	(1)
Transmitter power Radiated	2.14 dB	(1)
Conducted spurious emissions 9kHz~40GHz	1.60 dB	(1)
Radiated spurious emissions 9kHz~40GHz	2.20 dB	(1)
Conducted Emissions 9kHz~30MHz	3.20 dB	(1)
Radiated Emissions 30~1000MHz	4.70 dB	(1)
Radiated Emissions 1~18GHz	5.00 dB	(1)
Radiated Emissions 18~40GHz	5.54 dB	(1)
Occupied Bandwidth	2.80 dB	(1)

Note (1): This uncertainty represents an expanded uncertainty expressed at approximately the 95% confidence level using a coverage factor of k=1.96.

1.6. Environmental conditions

During the measurement the environmental conditions were within the listed ranges:

Temperature:	15~35°C
Relative Humidity:	30~60 %
Air Pressure:	950~1050mba

2. GENERAL INFORMATION

2.1. Client Information

Applicant:	Shenzhen Funpower General Technology Co., Ltd.
Address:	Room 201B,Habor Venture Building, No.1041 Houhai Avenue, Shekou,Nanshan District,Shenzhen City,PRC.
Manufacturer:	Shenzhen Funpower General Technology Co., Ltd.
Address:	Room 201B,Habor Venture Building, No.1041 Houhai Avenue, Shekou,Nanshan District,Shenzhen City,PRC.

2.2. General Description of EUT

Product Name:	Remote Control Transmitter
Model/Type reference:	FT3313YD
Trademark:	N/A
Listed models:	N/A
Model Difference:	N/A
Power supply:	N/A
Power supply(Battery):	DC 3.0V
Hardware version:	V1.0
Software version:	V1.0
RF Specification	
Operation frequency:	433.92MHz
Modulation Type:	ASK
Modulation connector:	<input checked="" type="checkbox"/> Without external <input type="checkbox"/> External
Occupied bandwidth	>25KHz
Product type:	<input checked="" type="checkbox"/> Wideband deceive <input type="checkbox"/> Narrowband deceive
Channel number:	1
Antenna type:	PCB antenna
Antenna gain:	0dBi

2.3. Test Mode

The EUT was operated at continuous transmitting mode that was for the purpose of the measurements. All testing shall be performed under maximum output power condition, and to measure its highest possible emissions level, more detailed description as follows:

Test Mode	Description	Remark
1	TX	DC 3.0V

2.4. Measurement Instruments List

Tonscend JS0806-2 Test system					
Item	Test Equipment	Manufacturer	Model No.	Serial No.	Cal. Until
1	Spectrum Analyzer	R&S	FSV40-N	101798	04/07/2021
2	Vector Signal Generator	Agilent	N5182A	MY50142520	04/07/2021
3	Analog Signal Generator	HP	83752A	3344A00337	04/07/2021
4	Power Sensor	Agilent	E9304A	MY50390009	04/07/2021
5	Power Sensor	Agilent	E9300A	MY41498315	04/07/2021
6	Wideband Radio Communication Tester	R&S	CMW500	157282	04/07/2021
7	Climate Chamber	Angul	AGNH80L	1903042120	04/07/2021
8	Dual Output DC Power Supply	Agilent	E3646A	MY40009992	04/07/2021
9	RF Control Unit	Tonscend	JS0806-2	/	04/07/2021

Transmitter spurious emissions & Receiver spurious emissions					
Item	Test Equipment	Manufacturer	Model No.	Serial No.	Cal. Until
1	EMI Test Receiver	R&S	ESR	102525	04/07/2021
2	High Pass Filter	Chengdu E-Microwave	OHF-3-18-S	0E01901038	03/27/2021
3	High Pass Filter	Chengdu E-Microwave	OHF-6.5-18-S	0E01901039	03/27/2021
4	Spectrum Analyzer	HP	8593E	3831U02087	04/07/2021
5	Ultra-Broadband logarithmic period Antenna	Schwarzbeck	VULB 9163	01230	03/29/2023
6	Loop Antenna	Beijin ZHINAN	ZN30900C	18050	03/25/2021
7	Spectrum Analyzer	R&S	FSV40-N	101798	04/07/2021
8	Horn Antenna	Schwarzbeck	BBHA 9120 D	2023	03/29/2023
9	Pre-Amplifier	Schwarzbeck	BBV 9745	9745#129	04/07/2021
10	Pre-Amplifier	EMCI	EMC051835SE	980662	04/07/2021

Item	Test Equipment	Manufacturer	Model No.	Serial No.	Cal. Until
1	LISN	R&S	ENV432	1326.6105.02	03/27/2021
2	EMI Test Receiver	R&S	ESR	102524	04/07/2021
3	Manual RF Switch	JS TOYO	/	MSW-01/002	04/07/2021

Note:

1)The Cal. Interval was one year.

2)The cable loss has calculated in test result which connection between each test instruments.

2.5. Test Software

Software name	Model	Version
Conducted emission Measurement Software	EZ-EMC	EMC-Con 3A1.1
Radiated emission Measurement Software	EZ-EMC	FA-03A.2.RE
Bluetooth and WIFI Test System	JS1120-3	2.5.77.0418

3. TEST ITEM AND RESULTS

3.1. Antenna requirement

Requirement

FCC CFR Title 47 Part 15 Subpart C Section 15.203:

An intentional radiator shall be designed to ensure that no antenna other than that furnished by the responsible party shall be used with the device. The use of a permanently attached antenna or of an antenna that uses a unique coupling to the intentional radiator, the manufacturer may design the unit so that a broken antenna can be replaced by the user, but the use of a standard antenna jack or electrical connector is prohibited.

Test Result

The directional gain of the antenna less than 6dBi, please refer to the EUT internal photographs antenna photo.

Note: The antenna is permanently fixed to the EUT

3.2. Conducted Emission

Limit

Conducted Emission Test Limit

Frequency	Maximum RF Line Voltage (dB μ V)	
	Quasi-peak Level	Average Level
150kHz~500kHz	66 ~ 56 *	56 ~ 46 *
500kHz~5MHz	56	46
5MHz~30MHz	60	50

Notes:

- (1) *Decreasing linearly with logarithm of the frequency.
- (2) The lower limit shall apply at the transition frequencies.
- (3) The limit decrease in line with the logarithm of the frequency in the range of 0.15 to 0.50MHz.

Test Configuration

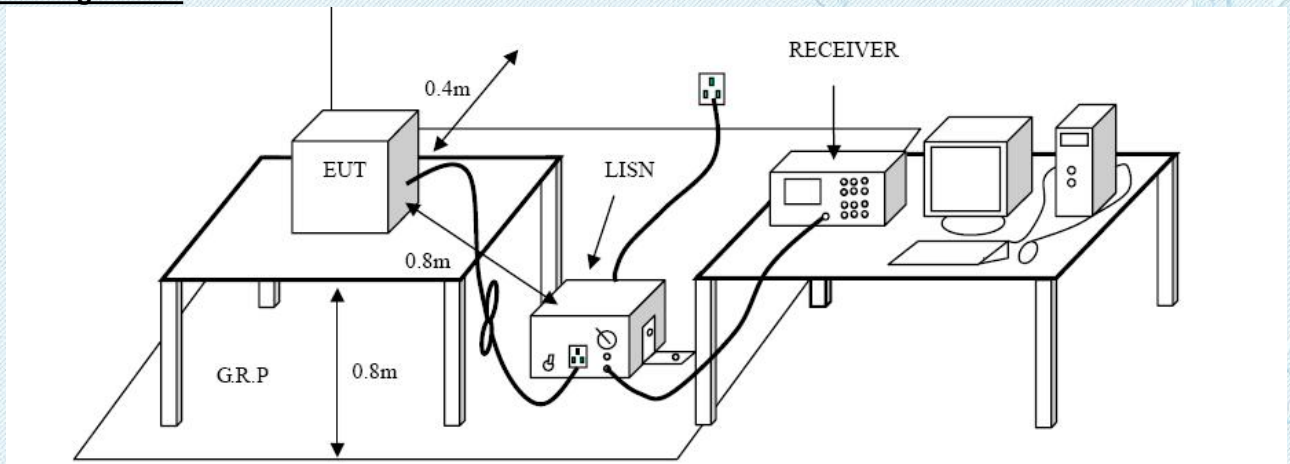

Test Procedure

1. The EUT was setup according to ANSI C63.10:2013 requirements.
2. The EUT was placed on a platform of nominal size, 1 m by 1.5 m, raised 80 cm above the conducting ground plane. The vertical conducting plane was located 40 cm to the rear of the EUT. All other surfaces of EUT were at least 80 cm from any other grounded conducting surface.
3. The EUT and simulators are connected to the main power through a line impedances stabilization network (LISN). The LISN provides a 50ohm /50uH coupling impedance for the measuring equipment.
The peripheral devices are also connected to the main power through a LISN. (Please refer to the block diagram of the test setup and photographs)
4. Each current-carrying conductor of the EUT power cord, except the ground (safety) conductor, was individually connected through a LISN to the input power source.
5. The excess length of the power cord between the EUT and the LISN receptacle were folded back and forth at the center of the lead to form a bundle not exceeding 40 cm in length.
6. Conducted Emissions were investigated over the frequency range from 0.15MHz to 30MHz using a receiver bandwidth of 9 kHz.
7. During the above scans, the emissions were maximized by cable manipulation.

Test Mode:

Please refer to the clause 2.3.

Test Results

- Passed Not Applicable

3.3. Occupied Bandwidth

Limit

The bandwidth of the emission shall be no wider than 0.25% of the center frequency

Test Configuration

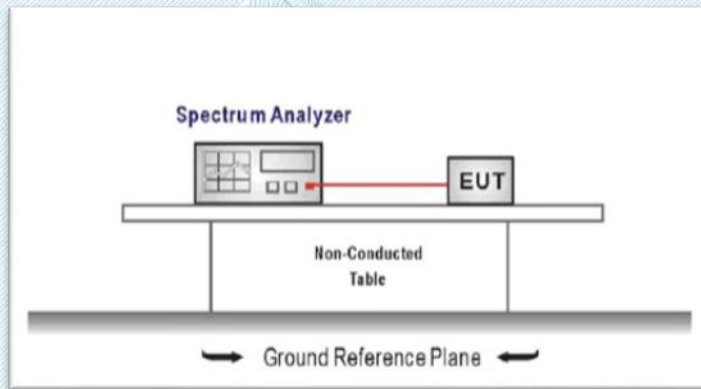

Test Procedure

1. The transmitter output was connected to the spectrum analyzer through an attenuator, the path loss was compensated to the results for each measurement.
2. Set to the maximum power setting and enable the EUT transmit continuously
3. Use the following spectrum analyzer settings:
 Span = approximately 2 to 3 times the 99% bandwidth, centered on a operation channel
 RBW \geq 1% of the 20 dB bandwidth, VBW \geq RBW
 Sweep = auto, Detector function = peak, Trace = max hold
4. Measure and record the results in the test report.

Test Mode

Please refer to the clause 2.3.

Test Results

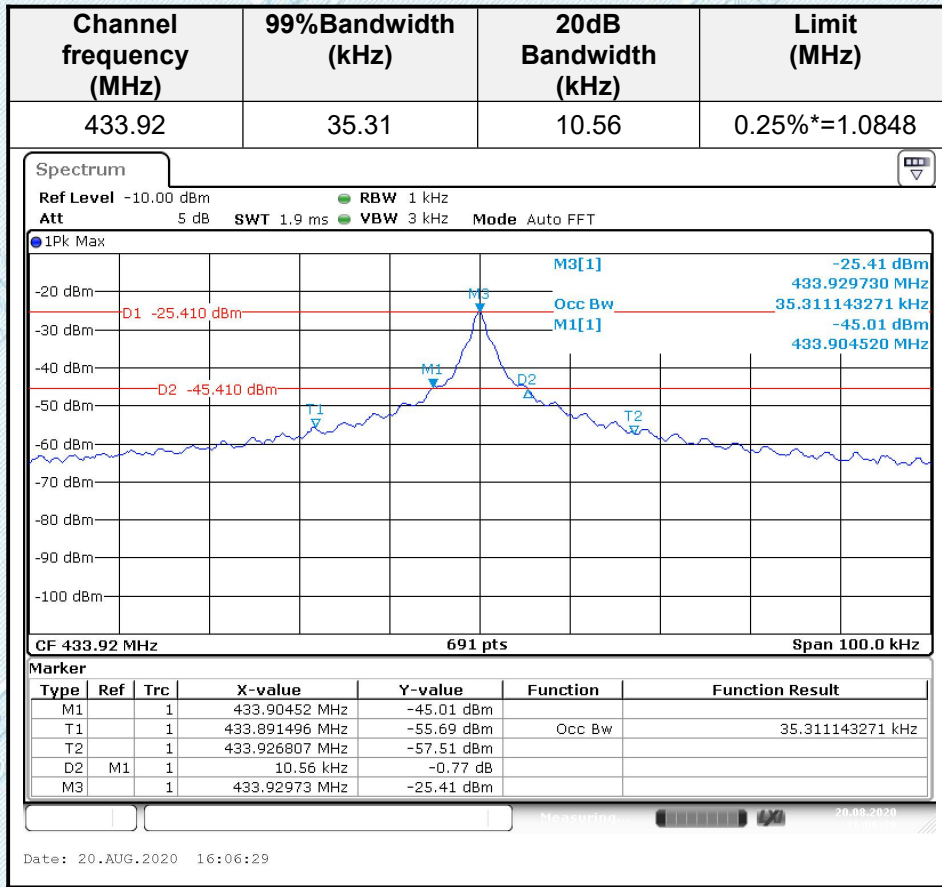

3.4. Deactivation Time

Limit

A manually operated transmitter shall employ a switch that will auto-matically deactivate the transmitter within not more than 5 seconds of being released.

Test Configuration

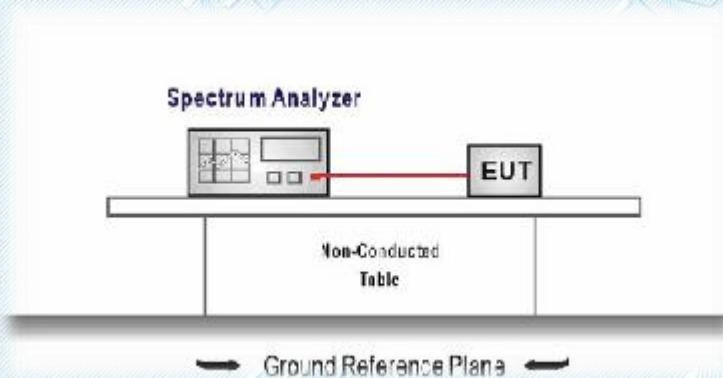

Test Procedure

1. The transmitter output was connected to the spectrum analyzer through an attenuator, the path loss was compensated to the results for each measurement.
2. Set to the maximum power setting and enable the EUT transmit continuously
3. Use the following spectrum analyzer settings:
 Frequency=Center carrier frequency
 RBW=100KHz, VBW=300KHz, Span= 0,
 Sweep time= 10 second, Detector function = peak, Trace = single
4. Measure and record the results in the test report.

Test Mode

Please refer to the clause 2.3.

Test Results

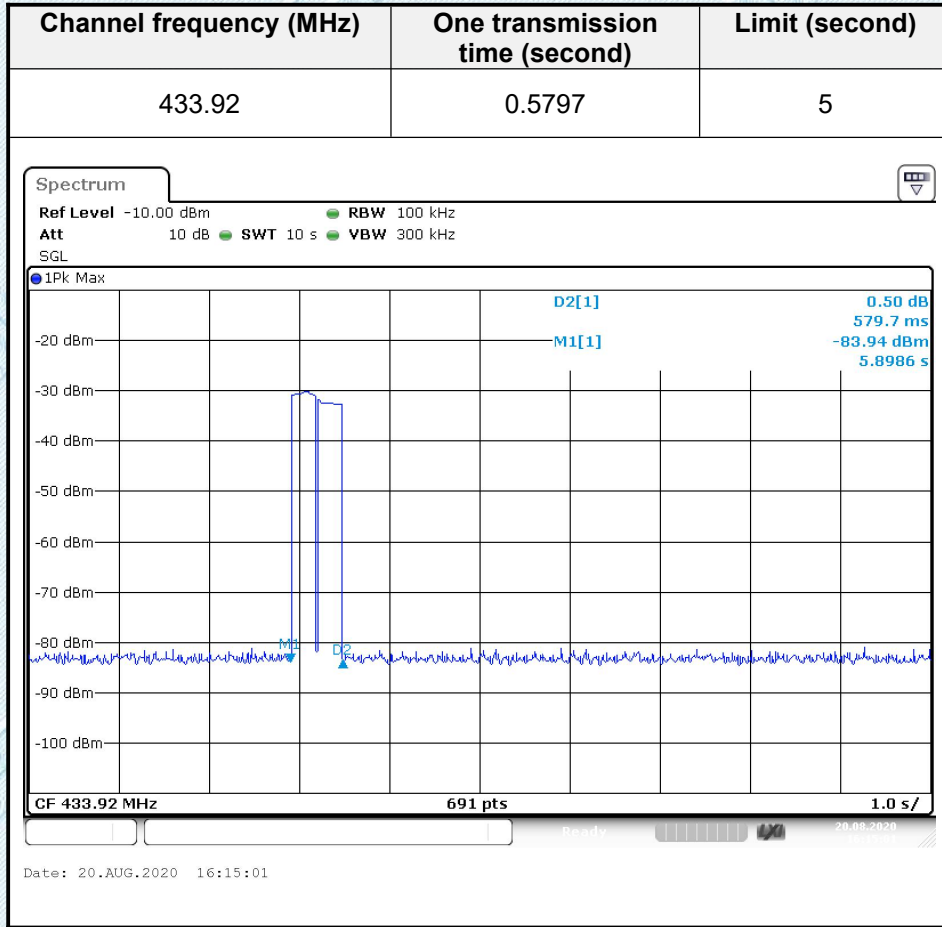

3.5. Spurious Emission (radiated)

Limit

FCC CFR Title 47 Part 15 Subpart C Section 15.209

Radiated Emission Limits (9 kHz~1000 MHz)

Frequency (MHz)	Field Strength (microvolt/meter)	Measurement Distance (meters)
0.009~0.490	2400/F(KHz)	300
0.490~1.705	24000/F(KHz)	30
1.705~30.0	30	30
30~88	100	3
88~216	150	3
216~960	200	3
Above 960	500	3

The field strength of emissions from intentional radiators operated **average value** under this section shall not exceed the following

Fundamental frequency	Field strength of fundamental (millivolts/meter)	Field strength of harmonics (microvolts/meter)
260 - 470 MHz	3,750 to 12,500 **	375 to 1,250 **

** linear interpolations

F is 433.92MHz

Field strength of fundamental: $\mu V/m$ at 3 meters = $41.6667(F) - 7083.3420$

Field strength of harmonics: $\mu V/m$ at 3 meters = $4.16667(F) - 708.3342$

Test Configuration

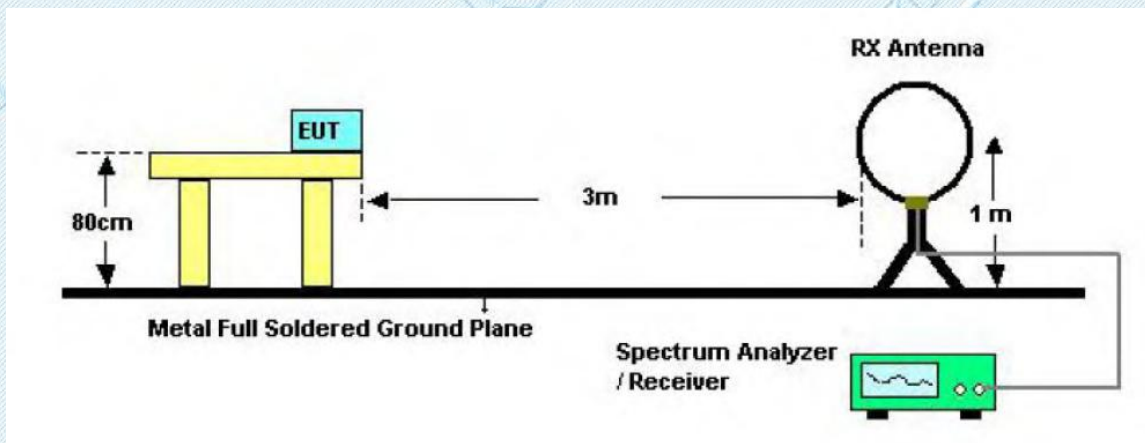

Below 30MHz Test Setup

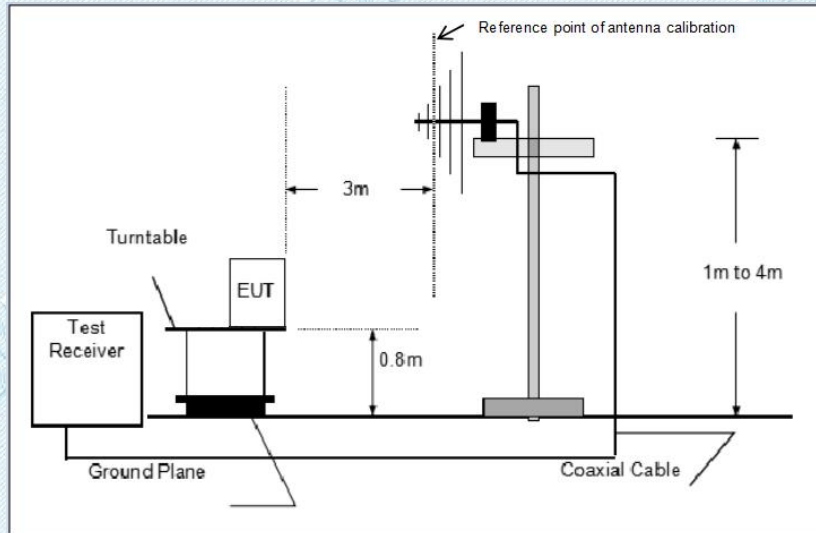

Below 1000MHz Test Setup

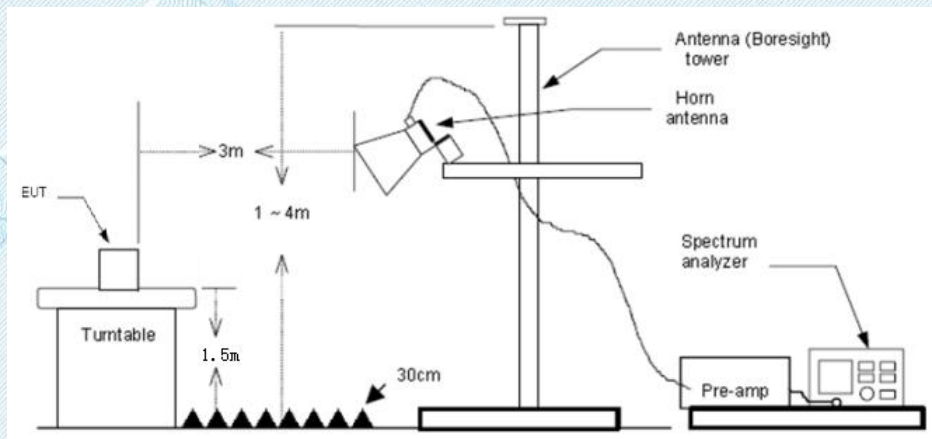

Above 1GHz Test Setup

Test Procedure

1. The EUT was setup and tested according to ANSI C63.10:2013
2. The EUT is placed on a turn table which is 0.8 meter above ground for below 1 GHz, and 1.5 m for above 1 GHz. The turn table is rotated 360 degrees to determine the position of the maximum emission level.
3. The EUT was set 3 meters from the receiving antenna, which was mounted on the top of a variable height antenna tower.
4. For each suspected emission, the EUT was arranged to its worst case and then tune the Antenna tower (from 1 m to 4 m) and turntable (from 0 degree to 360 degrees) to find the maximum reading. A pre-amp and a high pass filter are used for the test in order to get better signal level to comply with the guidelines.
5. Set to the maximum power setting and enable the EUT transmit continuously.
6. Use the following spectrum analyzer settings
 - (1) Span shall wide enough to fully capture the emission being measured;
 - (2) Below 1 GHz:
 RBW=120 kHz, VBW=300 kHz, Sweep=auto, Detector function=peak, Trace=max hold;
 If the emission level of the EUT measured by the peak detector is 3 dB lower than the applicable limit, the peak emission level will be reported. Otherwise, the emission measurement will be repeated using the quasi-peak detector and reported.
 - (3) From 1 GHz to 10th harmonic:
 RBW=1MHz, VBW=3MHz Peak detector for Peak value.
 RBW=1MHz, VBW=10Hz RMS detector for Average value.

Test Mode

Please refer to the clause 2.3.

Test Result

The value is less than the limit value 20dB.

9 KHz~30 MHz , 30MHz~1GHz and 1GHz~6GHz

From 9 KHz~30 MHz, 30MHz~1GHz and 1GHz~6GHz: Conclusion: PASS

Note:

- 1) Final level = Reading level + Correct Factor
Correct Factor=Antenna Factor + Cable Loss -Preamplifier Factor
- 2) The emission levels of other frequencies are very lower than the limit and not show in test report.
- 3) The amplitude of spurious emissions which are attenuated by more than 20dB below the permissible value has no need to be reported.

T_{on} (ms)	$T_{on}+T_{off}$ (ms)
$36*(1.4783-1.1884)+40*0.8696=45.2204$	100
Duty cycle factor (dB)= $20\log(T_{on} / (T_{on} + T_{off}))$ (dB) = -6.89(dB)	

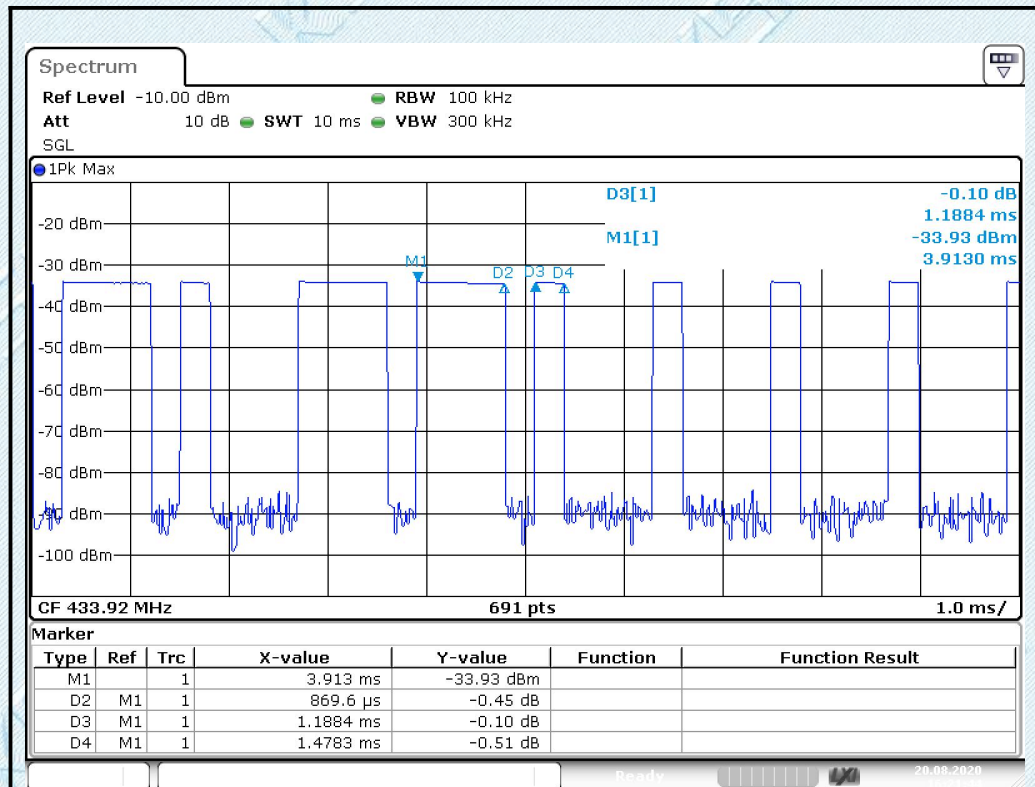

Date: 20.AUG.2020 16:21:44

Pulse 1

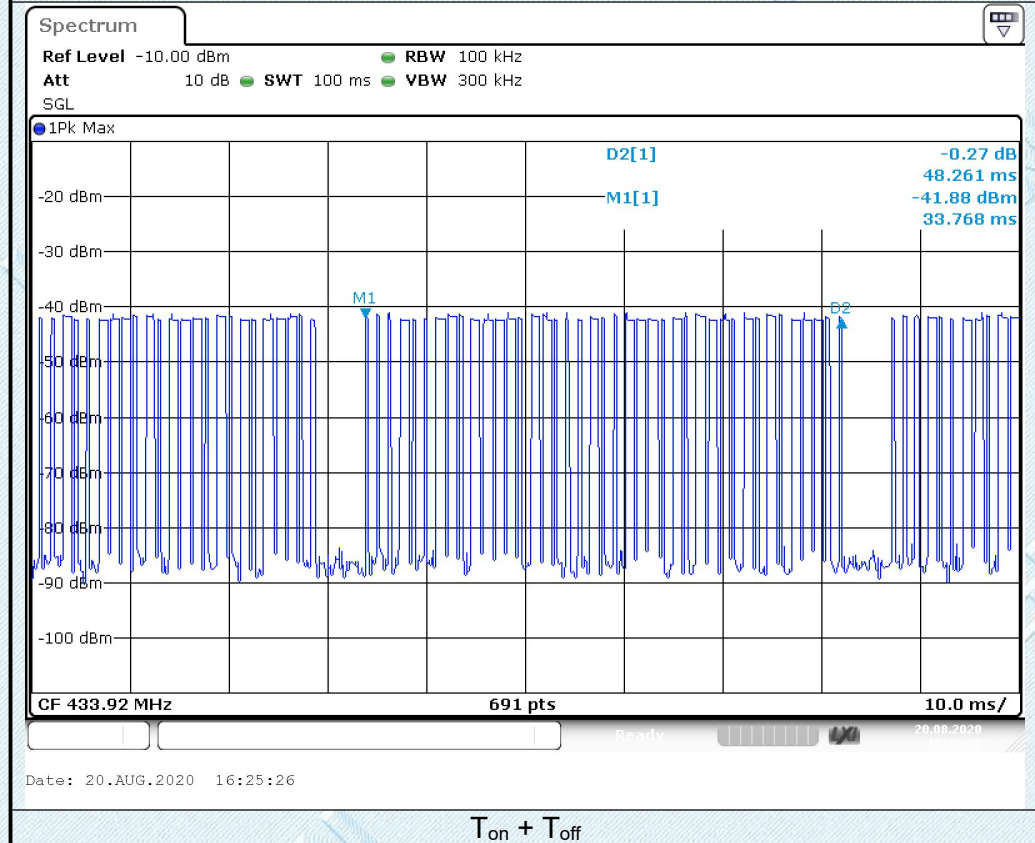

Date: 20.AUG.2020 16:25:26

■ 30MHz~ 1000MHz

Test Channel				433.92MHz			
Frequency (MHz)	Reading Level (dBuV)	Correct Factor (dB/m)	Final level (dBuV/m)	Limit Line (dBuV/m)	Margin Limit (dB)	Polarization	Test value
47.1268	24.94	-10.07	14.87	40.00	-25.13	Vertical	QP
101.3240	25.13	-11.89	13.24	43.50	-30.26	Vertical	QP
242.5252	25.30	-10.16	15.14	46.00	-30.86	Vertical	QP
433.9200	82.28	-4.59	77.69	100.83	-23.14	Vertical	Peak
300.0514	29.62	-8.76	20.86	46.00	-25.14	Vertical	QP
867.9120	57.93	1.12	59.05	80.83	-21.78	Vertical	Peak
34.9801	27.57	-12.95	14.62	40.00	-25.38	Horizontal	QP
43.3078	24.97	-10.60	14.37	40.00	-25.63	Horizontal	QP
98.8324	24.97	-11.98	12.99	43.50	-30.51	Horizontal	QP
433.9200	87.49	-4.59	82.90	100.83	-17.93	Horizontal	Peak
265.2102	25.23	-9.58	15.65	46.00	-30.35	Horizontal	QP
867.9120	74.09	1.12	62.21	80.83	-18.62	Horizontal	Peak

Frequency (MHz)	Peak Level (dBuV/m)	Duty cycle factor(dB)	AV Level (dBuV/m)	FCC Limit (dBμV/m)	Margin (dB)	Polarization
433.9200	77.69	-6.89	70.80	80.83	-21.19	Vertical
867.9120	59.05	-6.89	52.16	60.83	-15.52	Vertical
433.9200	82.90	-6.89	76.01	80.83	-4.18	Horizontal
867.9120	62.21	-6.89	55.32	60.83	-5.51	Horizontal

Note: Duty cycle factor = 20log (Duty cycle), Duty cycle = $T_{on} / (T_{on} + T_{off})$

■ 1GHz~ 6GHz

Test Channel				433.92MHz			
Frequency (MHz)	Reading Level (dBuV)	Correct Factor (dB/m)	Final level (dBuV/m)	Limit Line (dBuV/m)	Margin Limit (dB)	Polarization	Test value
1301.600	62.53	-11.97	50.56	74.00	-23.44	Vertical	Peak
1735.600	52.90	-11.35	41.55	74.00	-32.45	Vertical	
2169.200	62.90	-10.99	51.91	74.00	-22.09	Vertical	
2603.200	64.50	-10.82	53.68	74.00	-20.32	Vertical	
3037.600	55.54	-10.52	45.02	74.00	-28.98	Vertical	
3471.600	51.72	-9.73	41.99	74.00	-32.01	Vertical	
1301.600	70.72	-11.97	58.75	74.00	-15.25	Horizontal	
1735.600	56.87	-11.35	45.52	74.00	-28.48	Horizontal	
2169.600	64.73	-10.99	53.74	74.00	-20.26	Horizontal	
2603.600	70.11	-10.82	59.29	74.00	-14.71	Horizontal	
3037.200	60.71	-10.52	50.19	74.00	-23.81	Horizontal	
3471.200	59.36	-9.73	49.63	74.00	-24.37	Horizontal	

Frequency (MHz)	Peak Level (dBuV/m)	Duty cycle factor	AV Level (dBuV/m)	FCC Limit (dBμV/m)	Margin (dB)	Polarization
1301.600	50.56	-6.89	43.67	60.83	-17.16	Vertical
1735.600	41.55	-6.89	34.66	60.83	-26.17	Vertical
2169.200	51.91	-6.89	45.02	60.83	-15.81	Vertical
2603.200	53.68	-6.89	46.79	60.83	-14.04	Vertical
3037.600	45.02	-6.89	38.13	60.83	-22.70	Vertical
3471.600	41.99	-6.89	35.10	60.83	-25.73	Vertical
1301.600	58.75	-6.89	51.86	60.83	-8.97	Horizontal
1735.600	45.52	-6.89	38.63	60.83	-22.20	Horizontal
2169.600	53.74	-6.89	46.85	60.83	-13.98	Horizontal
2603.600	59.29	-6.89	52.40	60.83	-8.43	Horizontal
3037.200	50.19	-6.89	43.30	60.83	-17.53	Horizontal
3471.200	49.63	-6.89	42.74	60.83	-18.09	Horizontal

Note: Duty cycle factor = $20 \log(\text{Duty cycle})$, Duty cycle = $T_{on} / (T_{on} + T_{off})$

4.EUT TEST PHOTOS

Reference to the document No.: Test Photos.

5. PHOTOGRAPHS OF EUT CONSTRUCTIONAL

Reference to the document No.: External Photos and Internal Photos.

*****THE END*****