



KSIGN (Guangdong) Testing Co., Ltd.

West Side of 1/F., Building C, Zone A, Fuyuan New Factory, Jiujiu Industrial Park,
Minzhu, Shatou, Shajing, Bao'an District, Shenzhen, Guangdong, People's Republic of China
Tel.: + (86)755-29852678 Fax: + (86)755-29852397 E-mail: info@gdksign.cn Website: www.gdksign.com

TEST REPORT

Report No...... : **KS2101S0440E**

FCC ID..... : **2ABUP-FT0315R**

Applicant..... : Shenzhen Funpower General Technology Co., Ltd.

Address..... : Room 201B,Habor Venture Building, No.1041 Houhai Avenue,
Shekou,Nanshan District,Shenzhen City, PRC.

Manufacturer..... : Shenzhen Funpower General Technology Co., Ltd.

Address..... : Room 201B,Habor Venture Building, No.1041 Houhai Avenue,
Shekou,Nanshan District,Shenzhen City,PRC.

Product Name..... : **Remote Control Transmitter**

Trade Mark..... : N/A

Model/Type reference..... : FT0315R

Listed Model(s)..... : N/A

Standard..... : **FCC CFR Title 47 Part 15 Subpart C Section 15.231**

Date of Receipt..... : Jan. 11, 2021

Date of Test Date..... : Jan. 11, 2021~Jan. 29, 2021

Date of issue..... : Jan. 29, 2021

Test result..... : **Pass**

Compiled by:
(Printed name+signature) Rory Huang

Supervised by:
(Printed name+signature) Eder Zhan

Approved by:
(Printed name+signature) Cary Luo

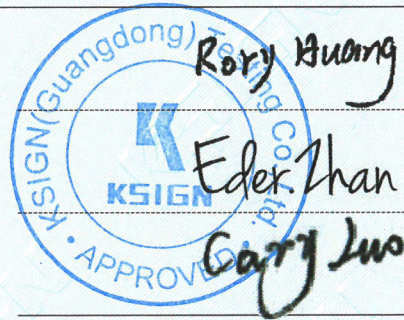

Testing Laboratory Name..... : **KSIGN(Guangdong) Testing Co., Ltd.**

Address..... : West Side of 1/F., Building C, Zone A, Fuyuan New Factory, Jiujiu
Industrial Park, Minzhu, Shatou, Shajing, Bao'an District, Shenzhen,
Guangdong, People's Republic of China

This test report may be duplicated completely for legal use with the approval of the applicant. It should not be reproduced except in full, without the written approval of our laboratory. The client should not use it to claim product endorsement by KSIGN. The test results in the report only apply to the tested sample. The test report shall be invalid without all the signatures of testing engineers, reviewer and approver. Any objections must be raised to KSIGN within 15 days since the date when the report is received. It will not be taken into consideration beyond this limit. The test report merely correspond to the test sample.

TABLE OF CONTENTS**Page**

1. TEST SUMMARY.....	3
1.1. TEST STANDARDS.....	3
1.2. REPORT VERSION.....	3
1.3. TEST DESCRIPTION.....	4
1.4. TEST FACILITY.....	5
1.5. MEASUREMENT UNCERTAINTY.....	6
1.6. ENVIRONMENTAL CONDITIONS.....	6
2. GENERAL INFORMATION.....	7
2.1. CLIENT INFORMATION.....	7
2.2. GENERAL DESCRIPTION OF EUT.....	7
2.3. TEST MODE.....	7
2.4. MEASUREMENT INSTRUMENTS LIST.....	8
2.5. TEST SOFTWARE.....	8
3. TEST ITEM AND RESULTS.....	9
3.1. ANTENNA REQUIREMENT.....	9
3.2. OCCUPIED BANDWIDTH.....	10
3.3. DEACTIVATION TIME.....	12
3.4. DUTY CYCLE CORRECTION FACTOR.....	14
3.5. SPURIOUS EMISSION (RADIATED).....	16
4. EUT TEST PHOTOS.....	24
5. PHOTOGRAPHS OF EUT CONSTRUCTIONAL.....	25

1. TEST SUMMARY

1.1. Test Standards

The tests were performed according to following standards:

FCC Rules Part 15.231: Periodic operation in the band 40.66–40.70 MHz and above 70 MHz.

ANSI C63.10-2013: American National Standard for Testing Unlicensed Wireless Devices.

1.2. Report version

Revised No.	Date of issue	Description
01	Jan. 29, 2021	Original

1.3. Test Description

FCC Rules Part 15.231			
Test Item	Standard Section	Result	Test Engineer
	FCC		
Antenna requirement	15.203	Pass	Rory Huang
Conducted Emissions	15.207	N/A	N/A
Radiated Spurious Emissions	15.209(a)/15.231(b)	Pass	Rory Huang
Deactivation Time	15.231(a)(1)	Pass	Rory Huang
Duty Cycle	15.231	Pass	Rory Huang
Occupied Bandwidth	15.231(c)	Pass	Rory Huang

Note: 1. The measurement uncertainty is not included in the test result.

2.N/A: means this test item is not applicable

3.The product is dry battery power supply.

1.4. Test Facility

Address of the report laboratory

KSIGN(Guangdong) Testing Co., Ltd.

West Side of 1/F., Building C, Zone A, Fuyuan New Factory, Jiujiu Industrial Park, Minzhu, Shatou, Shajing, Bao'an District, Shenzhen, Guangdong, People's Republic of China

Laboratory accreditation

The test facility is recognized, certified, or accredited by the following organizations:

CNAS-Lab Code: L13261

KSIGN(Guangdong) Testing Co., Ltd. has been assessed and proved to be in Compliance with CNAS-CL01 Accreditation Criteria for Testing and Calibration Laboratories (identical to ISO/IEC17025: 2017 General Requirements) for the Competence of Testing and Calibration Laboratories.

A2LA-Lab Cert. No.: 5457.01

KSIGN(Guangdong) Testing Co., Ltd. EMC Laboratory has been accredited by A2LA for technical competence in the field of electrical testing, and proved to be in compliance with ISO/IEC 17025:2017 General Requirements for the Competence of Testing and Calibration Laboratories and any additional program requirements in the identified field of testing.

IC Registration No.: CN0096

The 3m alternate test site of KSIGN(Guangdong) Testing Co., Ltd. EMC Laboratory has been registered by Certification and Engineer Bureau of Industry Canada for the performance of with Registration NO.: CN0096

FCC-Registration No.: CN1272

KSIGN(Guangdong) Testing Co., Ltd. EMC Laboratory has been registered and fully described in a report filed with the (FCC) Federal Communications Commission. The acceptance letter from the FCC is maintained in our files.

1.5. Measurement Uncertainty

The data and results referenced in this document are true and accurate. The reader is cautioned that there may be errors within the calibration limits of the equipment and facilities. The measurement uncertainty was calculated for all measurements listed in this test report acc. to TR-100028-01” Electromagnetic compatibility and Radio spectrum Matters (ERM);Uncertainties in the measurement of mobile radio equipment characteristics; Part 1” and TR-100028-02 “Electromagnetic compatibility and Radio spectrum Matters (ERM);Uncertainties in the measurement of mobile radio equipment characteristics; Part 2 “ and is documented in the KSIGN(Guangdong) Testing Co., Ltd. system acc. to DIN EN ISO/IEC 17025. Furthermore, component and process variability of devices similar to that tested may result in additional deviation. The manufacturer has the sole responsibility of continued compliance of the device. Below is the best measurement capability for KSIGN(Guangdong) Testing Co., Ltd.

Test Items	Measurement Uncertainty	Notes
Transmitter power conducted	0.42 dB	(1)
Transmitter power Radiated	2.14 dB	(1)
Conducted spurious emissions 9kHz~40GHz	1.60 dB	(1)
Radiated spurious emissions 9kHz~40GHz	2.20 dB	(1)
Conducted Emissions 9kHz~30MHz	3.20 dB	(1)
Radiated Emissions 30~1000MHz	4.70 dB	(1)
Radiated Emissions 1~18GHz	5.00 dB	(1)
Radiated Emissions 18~40GHz	5.54 dB	(1)
Occupied Bandwidth	2.80 dB	(1)

Note (1): This uncertainty represents an expanded uncertainty expressed at approximately the 95% confidence level using a coverage factor of k=1.96.

1.6. Environmental conditions

During the measurement the environmental conditions were within the listed ranges:

Temperature:	15~35°C
Relative Humidity:	30~60 %
Air Pressure:	950~1050mba

2. GENERAL INFORMATION

2.1. Client Information

Applicant:	Shenzhen Funpower General Technology Co., Ltd.
Address:	Room 201B,Habor Venture Building, No.1041 Houhai Avenue, Shekou,Nanshan District,Shenzhen City,PRC.
Manufacturer:	Shenzhen Funpower General Technology Co., Ltd.
Address:	Room 201B,Habor Venture Building, No.1041 Houhai Avenue, Shekou,Nanshan District,Shenzhen City,PRC.

2.2. General Description of EUT

Test Sample Number:	1-1-1(Normal Sample),1-1-2(Engineering Sample)
Product Name:	Remote Control Transmitter
Model/Type reference:	FT0315R
Trademark:	N/A
Listed models:	N/A
Model Difference:	N/A
Power supply:	DC 3V
Power supply(Battery):	N/A
Hardware version:	V1.0
Software version:	V1.0
RF Specification	
Operation frequency:	433.98MHz
Modulation Type:	ASK
Modulation connector:	<input checked="" type="checkbox"/> Without external <input type="checkbox"/> External
Occupied bandwidth	>25KHz
Product type:	<input checked="" type="checkbox"/> Wideband deceive <input type="checkbox"/> Narrowband deceive
Channel number:	1
Antenna type:	PCB antenna
Antenna gain:	0dBi

2.3. Test Mode

The EUT was operated at continuous transmitting mode that was for the purpose of the measurements. All testing shall be performed under maximum output power condition, and to measure its highest possible emissions level, more detailed description as follows:

Test Mode	Description	Remark
1	TX	DC 3V

2.4. Measurement Instruments List

Tonscend JS0806-2 Test system					
Item	Test Equipment	Manufacturer	Model No.	Serial No.	Cal. Until
1	Spectrum Analyzer	R&S	FSV40-N	101798	04/07/2021
2	Vector Signal Generator	Agilent	N5182A	MY50142520	04/07/2021
3	Analog Signal Generator	HP	83752A	3344A00337	04/07/2021
4	Power Sensor	Agilent	E9304A	MY50390009	04/07/2021
5	Power Sensor	Agilent	E9300A	MY41498315	04/07/2021
6	Wideband Radio Communication Tester	R&S	CMW500	157282	04/07/2021
7	Climate Chamber	Angul	AGNH80L	1903042120	04/07/2021
8	Dual Output DC Power Supply	Agilent	E3646A	MY40009992	04/07/2021
9	RF Control Unit	Tonscend	JS0806-2	/	04/07/2021

Transmitter spurious emissions & Receiver spurious emissions					
Item	Test Equipment	Manufacturer	Model No.	Serial No.	Cal. Until
1	EMI Test Receiver	R&S	ESR	102525	04/07/2021
2	High Pass Filter	Chengdu E-Microwave	OHF-3-18-S	0E01901038	03/27/2021
3	High Pass Filter	Chengdu E-Microwave	OHF-6.5-18-S	0E01901039	03/27/2021
4	Spectrum Analyzer	HP	8593E	3831U02087	04/07/2021
5	Ultra-Broadband logarithmic period Antenna	Schwarzbeck	VULB 9163	01230	03/29/2023
6	Loop Antenna	Beijin ZHINAN	ZN30900C	18050	03/25/2021
7	Spectrum Analyzer	R&S	FSV40-N	101798	04/07/2021
8	Horn Antenna	Schwarzbeck	BBHA 9120 D	2023	03/29/2023
9	Pre-Amplifier	Schwarzbeck	BBV 9745	9745#129	04/07/2021
10	Pre-Amplifier	EMCI	EMC051835SE	980662	04/07/2021

Item	Test Equipment	Manufacturer	Model No.	Serial No.	Cal. Until
1	LISN	R&S	ENV432	1326.6105.02	03/27/2021
2	EMI Test Receiver	R&S	ESR	102524	04/07/2021
3	Manual RF Switch	JS TOYO	/	MSW-01/002	04/07/2021

Note:

1)The Cal. Interval was one year.

2)The cable loss has calculated in test result which connection between each test instruments.

2.5. Test Software

Software name	Model	Version
Conducted emission Measurement Software	EZ-EMC	EMC-Con 3A1.1
Radiated emission Measurement Software	EZ-EMC	FA-03A.2.RE
Bluetooth and WIFI Test System	JS1120-3	2.5.77.0418

3. TEST ITEM AND RESULTS

3.1. Antenna requirement

Requirement

FCC CFR Title 47 Part 15 Subpart C Section 15.203:

An intentional radiator shall be designed to ensure that no antenna other than that furnished by the responsible party shall be used with the device. The use of a permanently attached antenna or of an antenna that uses a unique coupling to the intentional radiator, the manufacturer may design the unit so that a broken antenna can be replaced by the user, but the use of a standard antenna jack or electrical connector is prohibited.

Test Result

The directional gain of the antenna less than 6dBi, please refer to the EUT internal photographs antenna photo.

Note: The antenna is permanently fixed to the EUT

3.2. Occupied Bandwidth

Limit

The bandwidth of the emission shall be no wider than 0.25% of the center frequency

Test Configuration

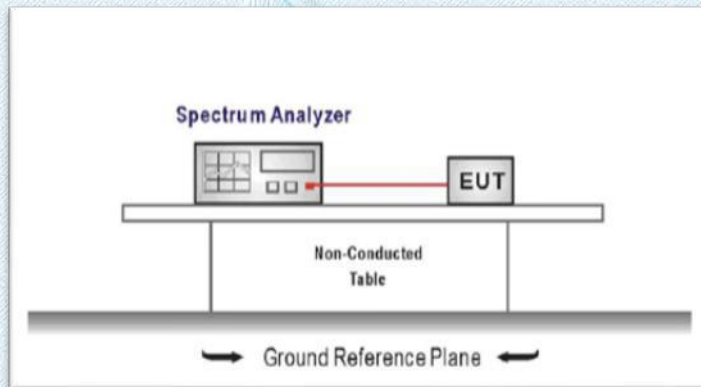

Test Procedure

1. The transmitter output was connected to the spectrum analyzer through an attenuator, the path loss was compensated to the results for each measurement.
2. Set to the maximum power setting and enable the EUT transmit continuously
3. Use the following spectrum analyzer settings:
 Span = approximately 2 to 3 times the 99% bandwidth, centered on a operation channel
 RBW \geq 1% of the 20 dB bandwidth, VBW \geq RBW
 Sweep = auto, Detector function = peak, Trace = max hold
4. Measure and record the results in the test report.

Test Mode

Please refer to the clause 2.3.

Test Results

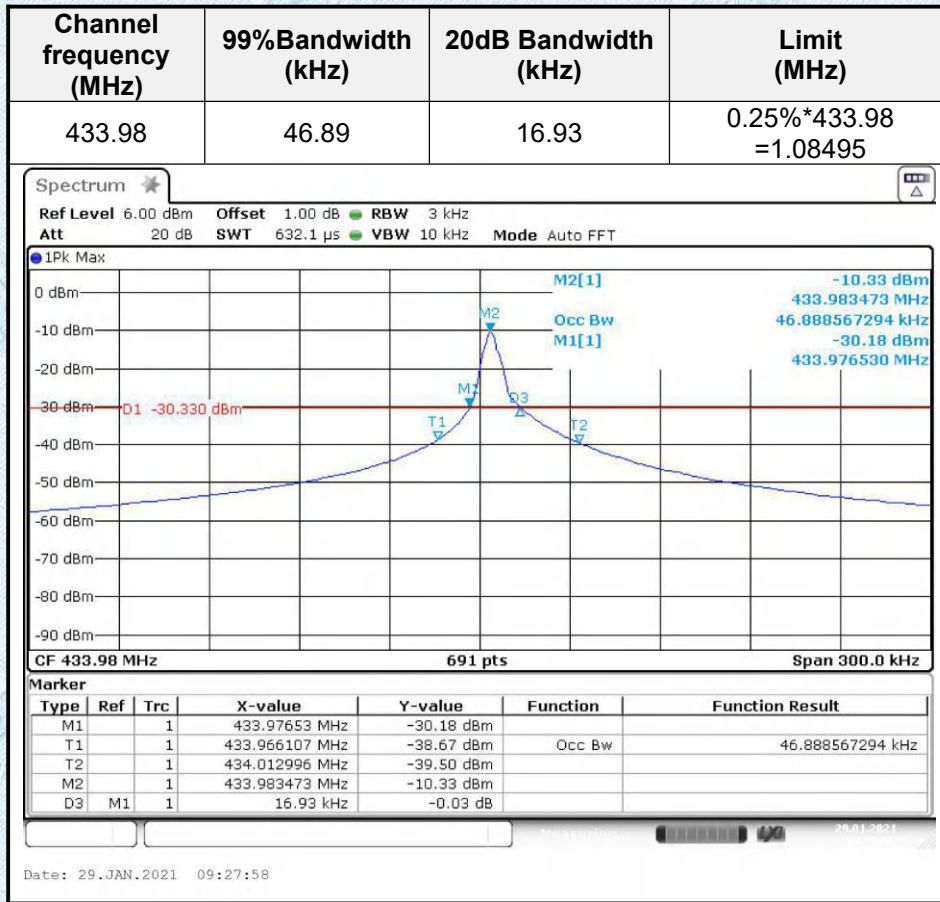

3.3. Deactivation Time

Limit

A manually operated transmitter shall employ a switch that will auto-matically deactivate the transmitter within not more than 5 seconds of being released.

Test Configuration

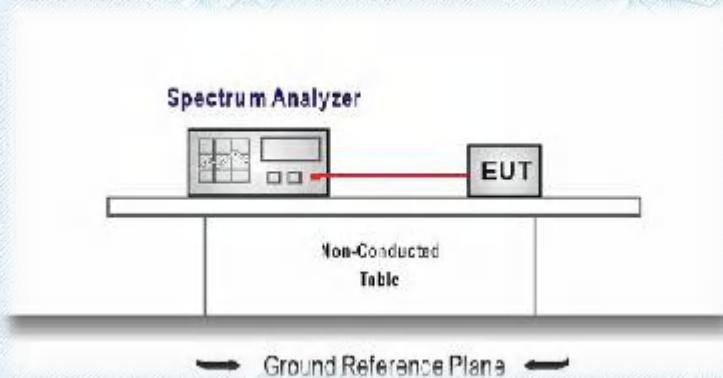

Test Procedure

1. The transmitter output was connected to the spectrum analyzer through an attenuator, the path loss was compensated to the results for each measurement.
2. Set to the maximum power setting and enable the EUT transmit continuously
3. Use the following spectrum analyzer settings:
 Frequency=Center carrier frequency
 RBW=100KHz, VBW=300KHz, Span= 0,
 Sweep time= 10 second, Detector function = peak, Trace = single
4. Measure and record the results in the test report.

Test Mode

Please refer to the clause 2.3.

Test Results

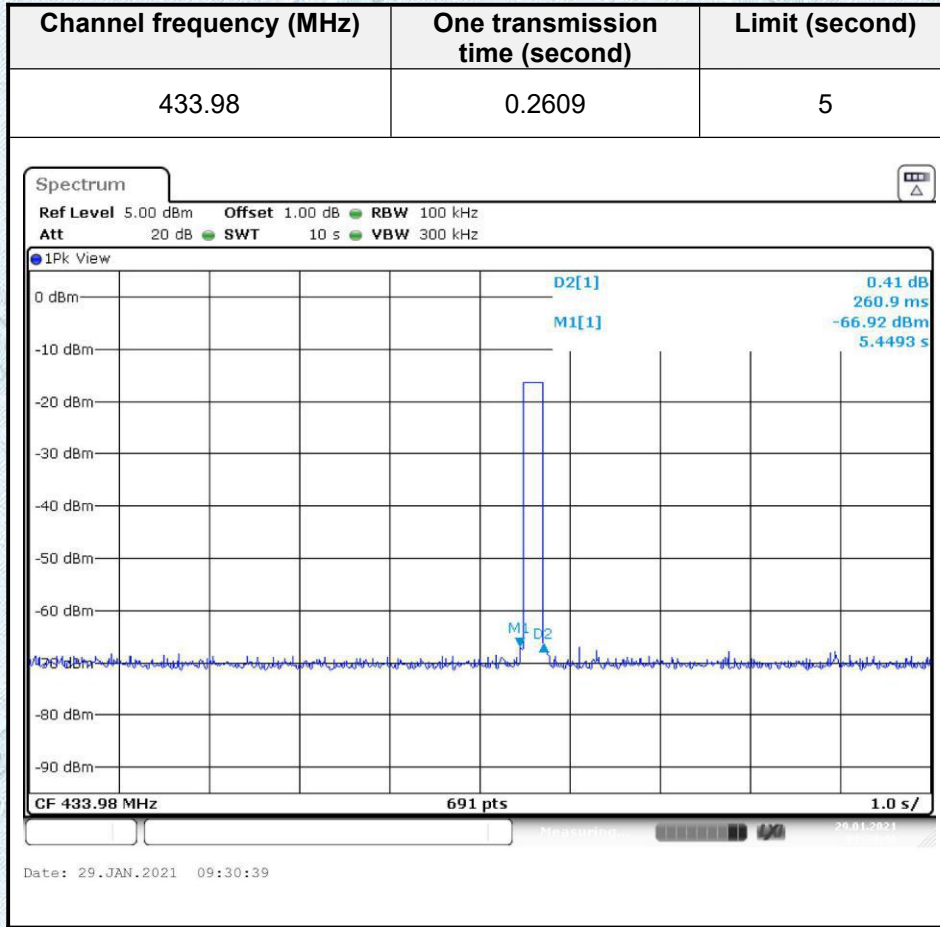

3.4. Duty Cycle Correction factor

Test Procedure

1. Set the parameters of SPA as below:
Centre frequency = Operation Frequency
RBW=100KHz; VBW=300KHz
Span: 0Hz
Sweep time: more than two pulse trains or more than each type of pulse occupancy time
2. Set the EUT to transmit by manually operated. Use the “Delta mark” function of SPA to find the period time between two pulse trains and each type of pulse occupancy time.
3. Record the plots and Reported.

Test Configuration

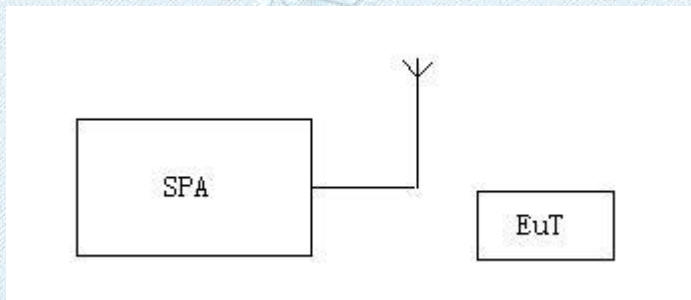

Test Mode

Please refer to the clause 2.3.

Test Results

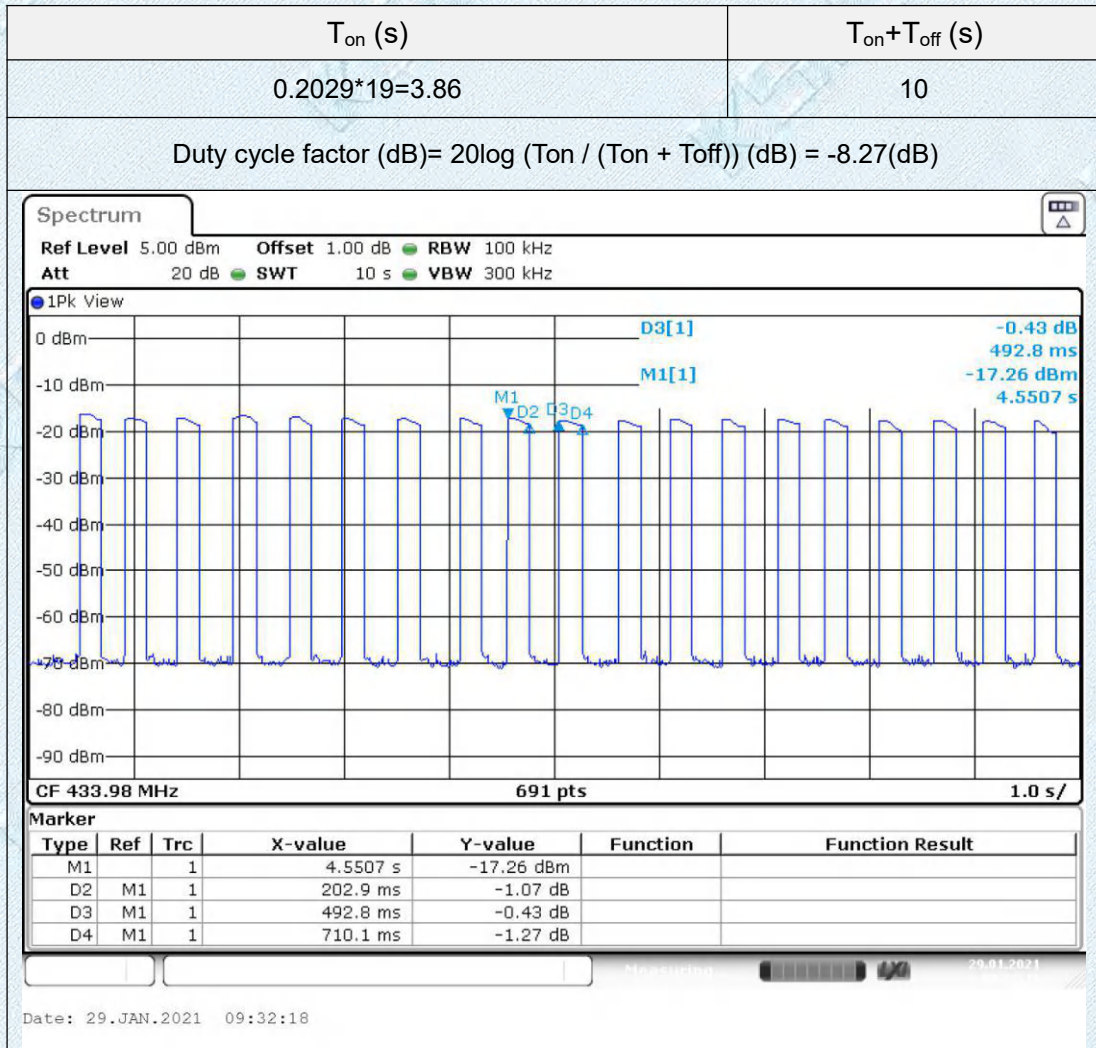

3.5. Spurious Emission (radiated)

Limit

FCC CFR Title 47 Part 15 Subpart C Section 15.209

Radiated Emission Limits (9 kHz~1000 MHz)

Frequency (MHz)	Field Strength (microvolt/meter)	Measurement Distance (meters)
0.009~0.490	2400/F(KHz)	300
0.490~1.705	24000/F(KHz)	30
1.705~30.0	30	30
30~88	100	3
88~216	150	3
216~960	200	3
Above 960	500	3

FCC CFR Title 47 Part 15 Subpart C Section 15.213(b)

The field strength of emissions from intentional radiators operated **average value** under this section shall not exceed the following

Fundamental frequency	Field strength of fundamental (millivolts/meter)	Field strength of harmonics (microvolts/meter)
260 - 470 MHz	3,750 to 12,500 **	375 to 1,250 **

** linear interpolations

F is 433.98MHz

Field strength of fundamental: $\mu V/m$ at 3 meters = $41.6667(F) - 7083.3420$

Field strength of harmonics: $\mu V/m$ at 3 meters = $4.16667(F) - 708.3342$

Test Configuration

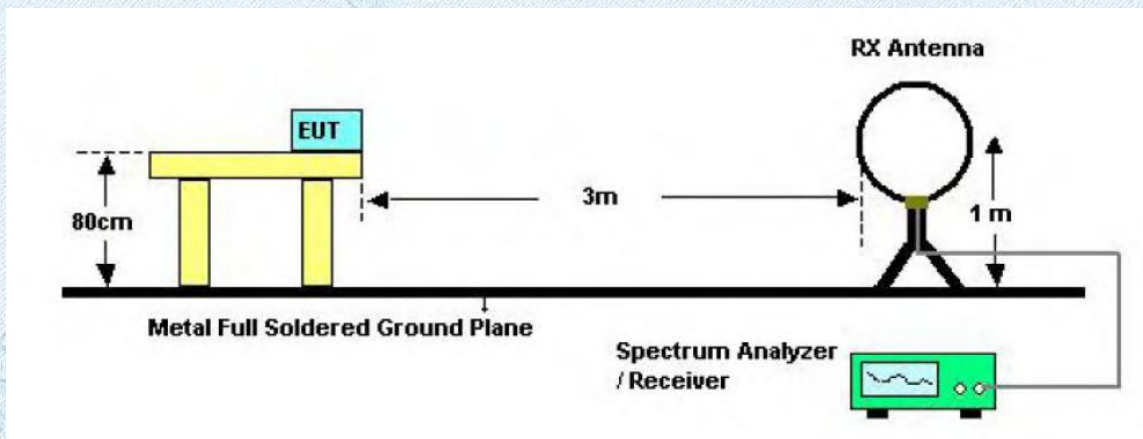

Below 30MHz Test Setup

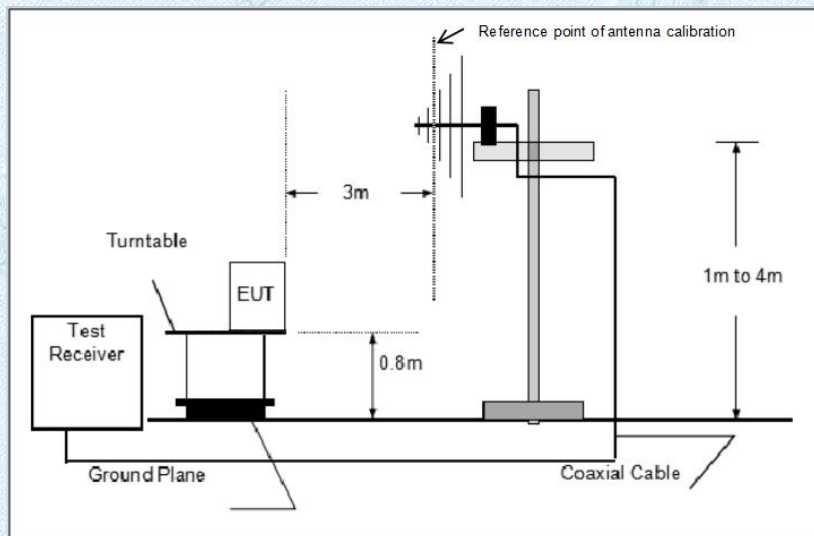

Below 1000MHz Test Setup

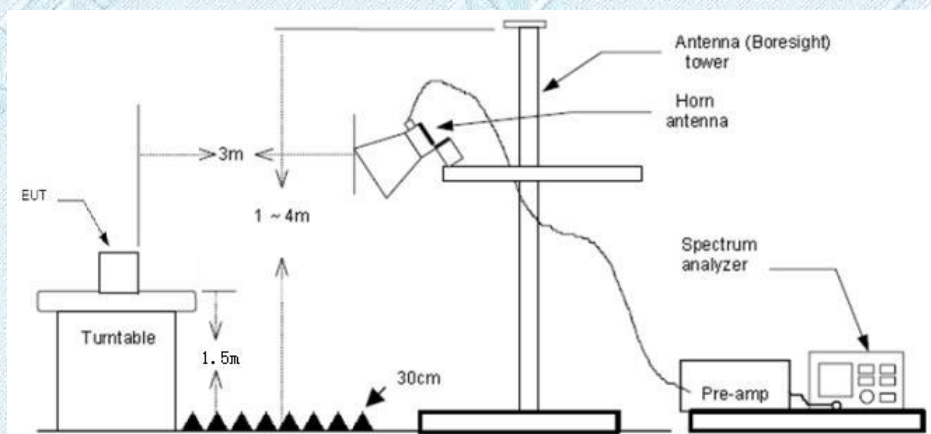

Above 1GHz Test Setup

Test Procedure

1. The EUT was setup and tested according to ANSI C63.10:2013
2. The EUT is placed on a turn table which is 0.8 meter above ground for below 1 GHz, and 1.5 m for above 1 GHz. The turn table is rotated 360 degrees to determine the position of the maximum emission level.
3. The EUT was set 3 meters from the receiving antenna, which was mounted on the top of a variable height antenna tower.
4. For each suspected emission, the EUT was arranged to its worst case and then tune the Antenna tower (from 1 m to 4 m) and turntable (from 0 degree to 360 degrees) to find the maximum reading. A pre-amp and a high pass filter are used for the test in order to get better signal level to comply with the guidelines.
5. Set to the maximum power setting and enable the EUT transmit continuously.
6. Use the following spectrum analyzer settings
 - (1) Span shall wide enough to fully capture the emission being measured;
 - (2) Below 1 GHz:
RBW=120 kHz, VBW=300 kHz, Sweep=auto, Detector function=peak, Trace=max hold;
If the emission level of the EUT measured by the peak detector is 3 dB lower than the applicable limit, the peak emission level will be reported. Otherwise, the emission measurement will be repeated using the quasi-peak detector and reported.
 - (3) From 1 GHz to 10th harmonic:
RBW=1MHz, VBW=3MHz Peak detector for Peak value.
RBW=1MHz, VBW=10Hz Peak detector for Average value.

Test Mode

Please refer to the clause 2.3.

Test Result**9 KHz~30 MHz , 30MHz-1GHz and 1GHz~5GHz**

From 9 KHz~30 MHz, 30MHz-1GHz and 1GHz~5GHz: Conclusion: PASS

Note:

- 1) Final level = Reading level + Correct Factor
Correct Factor=Antenna Factor + Cable Loss -Preamplifier Factor
- 2) The emission levels of other frequencies are very lower than the limit and not show in test report.
- 3) The amplitude of spurious emissions which are attenuated by more than 20dB below the permissible value has no need to be reported.

RADIATED EMISSION BELOW 30MHZ

No emission found between lowest internal used/generated frequencies to 30MHz.

■ 30MHz~ 1000MHz

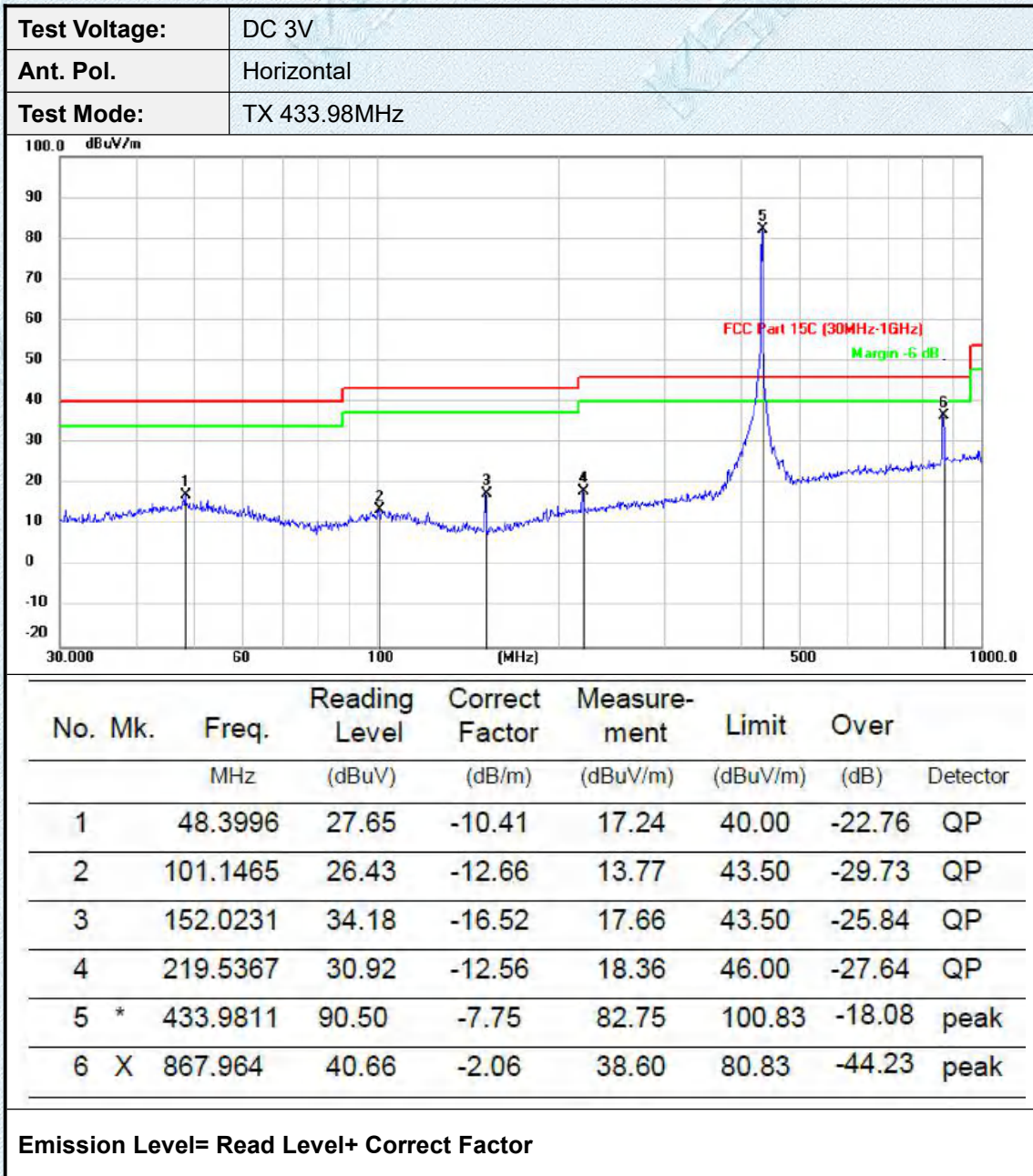

Test Voltage:	DC 3V
Ant. Pol.	Vertical
Test Mode:	TX 433.98MHz

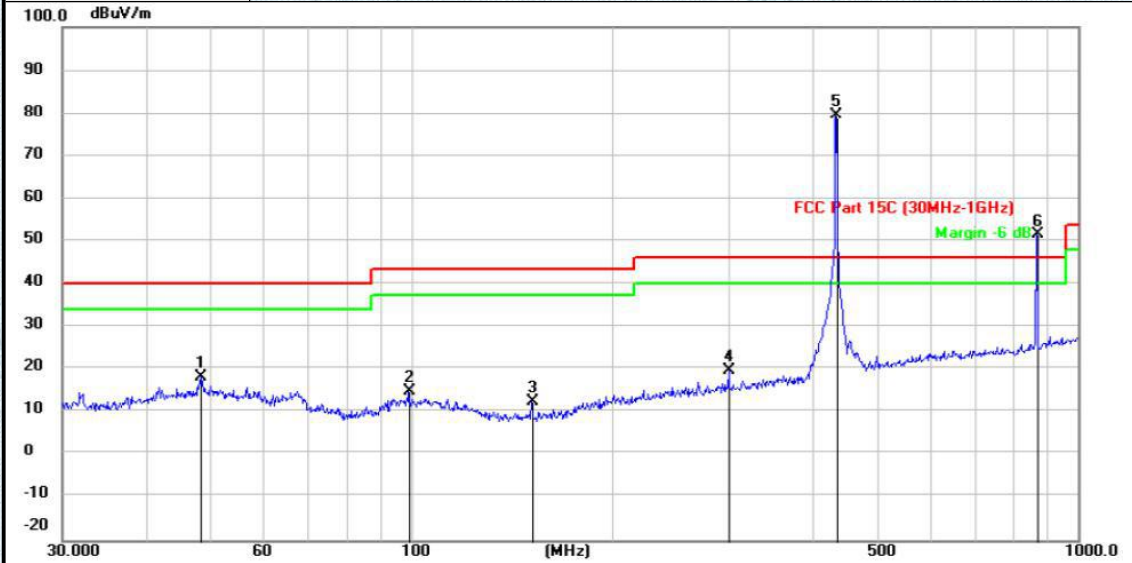

No.	Mk.	Freq. MHz	Reading Level (dBuV)	Correct Factor (dB/m)	Measure- ment (dBuV/m)	Limit (dBuV/m)	Over (dB)	Detector
1		48.3996	28.56	-10.41	18.15	40.00	-21.85	QP
2		99.3886	27.50	-12.67	14.83	43.50	-28.67	QP
3		151.9698	28.98	-16.52	12.46	43.50	-31.04	QP
4		300.0514	30.25	-10.58	19.67	46.00	-26.33	QP
5	*	433.9831	87.03	-7.75	79.28	100.83	-21.55	peak
6	X	867.964	53.62	-2.06	51.56	80.83	-29.27	peak

Emission Level= Read Level+ Correct Factor

Correct Factor=Antenna Factor + Cable Loss -Preamplifier Factor

Field Strength of Fundamental, Harmonic

Frequency (MHz)	Peak Level (dBuV/m)	Peak Level Limit (dBuV/m)	Margin (dB)	Polarization
433.98	79.28	100.83	-21.55	Vertical
867.964	51.56	80.83	-29.27	Vertical
433.98	82.75	100.83	-18.08	Horizontal
867.964	38.60	80.83	-42.23	Horizontal

Frequency (MHz)	Peak Level (dBuV/m)	Duty cycle factor(dB)	AV Level (dBuV/m)	AV Level Limit (dBuV/m)	Margin (dB)	Polarization
433.98	79.28	-8.27	71.01	80.83	-9.82	Vertical
867.964	51.56	-8.27	43.29	60.83	-17.54	Vertical
433.98	82.75	-8.27	74.48	80.83	-6.35	Horizontal
867.964	38.60	-8.27	30.33	60.83	-30.5	Horizontal

Note:

Duty cycle factor = $20\log(\text{Duty cycle})$, Duty cycle = $T_{on} / (T_{on} + T_{off})$

AV Level = Peak Level + Duty cycle factor

■ 1GHz~ 5GHz

Field Strength of Harmonic

Test Channel			433.98MHz				
Frequency (MHz)	Reading Level (dBuV/m)	Correct Factor (dB)	Final level (dBuV/m)	Limit Line (dBuV/m)	Margin (dB)	Polarization	Test value
1301.94	51.917	-10.313	41.604	80.83	-39.226	Vertical	Peak
1735.92	50.033	-10.297	39.736	80.83	-41.094	Vertical	
2169.920	63.525	-10.208	53.317	80.83	-27.513	Vertical	
2603.882	64.917	-10.496	54.421	80.83	-26.409	Vertical	
3471.850	52.033	-9.1288	42.9042	80.83	-37.9258	Vertical	
1301.94	51.522	-10.323	41.199	80.83	-39.631	Horizontal	
1735.92	49.831	-10.285	39.546	80.83	-41.284	Horizontal	
2169.920	63.271	-10.206	53.065	80.83	-27.765	Horizontal	
2603.882	62.049	-9.925	52.124	80.83	-28.706	Horizontal	
3471.850	51.834	-9.885	41.949	80.83	-38.881	Horizontal	

Correct Factor=Antenna Factor + Cable Loss -Preamplifier Factor

Frequency (MHz)	Peak Level (dBuV/m)	Duty cycle Factor	AV Level (dBuV/m)	FCC Limit (dBμV/m)	Margin (dB)	Polarization
1301.94	41.604	-8.27	33.334	60.83	-27.496	Vertical
1735.92	39.736	-8.27	31.466	60.83	-29.364	Vertical
2169.920	53.317	-8.27	45.047	60.83	-15.783	Vertical
2603.882	54.421	-8.27	46.151	60.83	-14.679	Vertical
3471.850	42.9042	-8.27	34.6342	60.83	-26.1958	Vertical
1301.94	41.199	-8.27	32.929	60.83	-27.901	Horizontal
1735.92	39.546	-8.27	31.276	60.83	-29.554	Horizontal
2169.920	53.065	-8.27	44.795	60.83	-16.035	Horizontal
2603.882	52.124	-8.27	43.854	60.83	-16.976	Horizontal
3471.850	41.949	-8.27	33.679	60.83	-27.151	Horizontal

Correct Factor=Antenna Factor + Cable Loss -Preamplifier Factor

Spurious Emission

Test Channel				433.98MHz			
Frequency (MHz)	Reading Level (dBuV/m)	Correct Factor (dB)	Final level (dBuV/m)	Limit Line (dBuV/m)	Margin (dB)	Polarization	Test value
1330.38	43.78	-10.891	32.889	74	-41.111	Vertical	Peak
1974.56	43.93	-10.905	33.025	74	-40.975	Vertical	
2641.63	48.79	-9.903	38.887	74	-35.113	Vertical	
1330.38	44.16	-10.632	33.528	74	-40.472	Horizontal	
1974.56	32.45	-10.602	21.848	74	-52.152	Horizontal	
2641.63	49.73	-9.886	39.844	74	-34.156	Horizontal	

Correct Factor=Antenna Factor + Cable Loss -Preamplifier Factor

Frequency (MHz)	Peak Level (dBuV/m)	Duty cycle factor	AV Level (dBuV/m)	FCC Limit (dBμV/m)	Margin (dB)	Polarization
1330.38	32.889	-8.27	24.619	54	-29.381	Vertical
1974.56	33.025	-8.27	24.755	54	-29.245	Vertical
2641.63	38.887	-8.27	30.617	54	-23.383	Vertical
1330.38	33.528	-8.27	25.258	54	-28.742	Horizontal
1974.56	21.848	-8.27	13.578	54	-40.422	Horizontal
2641.63	39.844	-8.27	31.574	54	-22.426	Horizontal

Note:

Duty cycle factor = 20log (Duty cycle), Duty cycle = Ton / (Ton + Toff)

AV Level=Peak Level +Duty cycle factor

4.EUT TEST PHOTOS

Radiated Measurement (Below 1GHz)



Radiated Measurement (Above 1GHz)

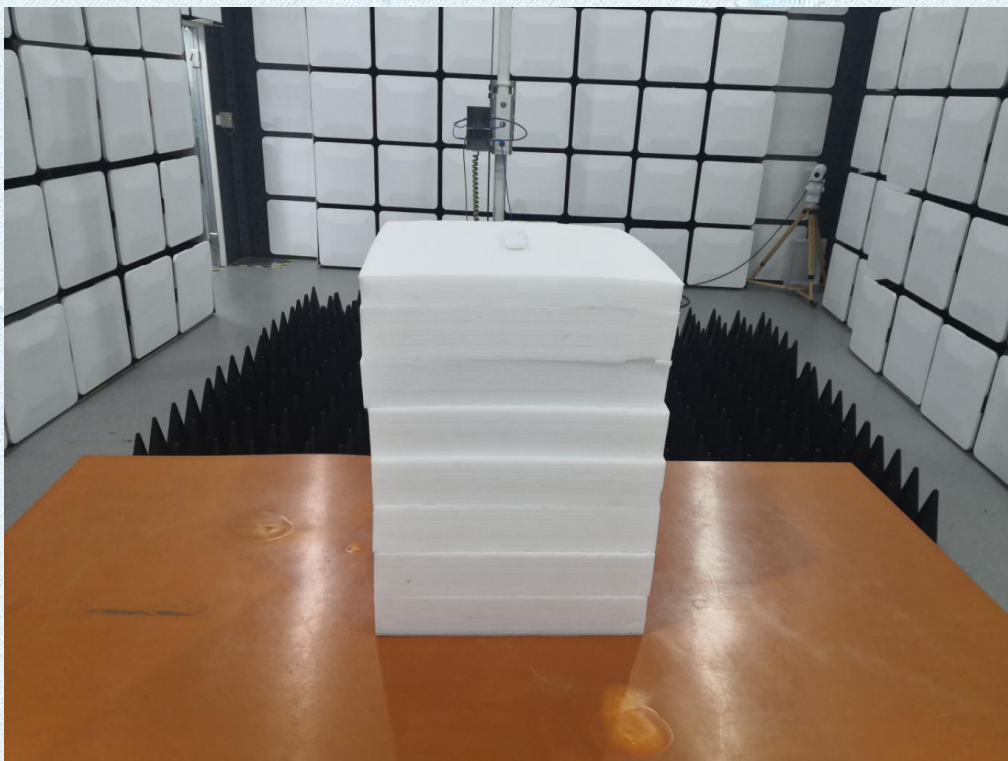

5. PHOTOGRAPHS OF EUT CONSTRUCTIONAL

Reference to the document No.: External Photos and Internal Photos.

*****THE END*****