

RADIO TEST REPORT

For

SHENZHEN SAMHOO SCI&TECH CO.,LTD

Digital Two Way Radio

Test Model: SPM6050

Prepared for : SHENZHEN SAMHOO SCI&TECH CO.,LTD
Address : Room 401, Building 2th, Huaqiangyun Industrial Park, Meixiu Road, Meilin, Futian District, Shenzhen, China

Prepared by : Shenzhen LCS Compliance Testing Laboratory Ltd.
Address : 1/F., Xingyuan Industrial Park, Tongda Road, Bao'an Avenue, Bao'an District, Shenzhen, Guangdong, China

Tel : (+86)755-82591330
Fax : (+86)755-82591332
Web : www.LCS-cert.com
Mail : webmaster@LCS-cert.com

Date of receipt of test sample : April 25, 2016
Number of tested samples : 1
Serial number : Prototype
Date of Test : April 25, 2016 ~ June 08, 2016
Date of Report : June 08, 2016

**RADIO TEST REPORT
FCC Part 90**

Report Reference No. : **LCS1606130856E**

Date of Issue : June 08, 2016

Testing Laboratory Name : **Shenzhen LCS Compliance Testing Laboratory Ltd.**

Address : 1/F., Xingyuan Industrial Park, Tongda Road, Bao'an Avenue,
Bao'an District, Shenzhen, Guangdong, China

Testing Location/ Procedure : Full application of Harmonised standards
Partial application of Harmonised standards
Other standard testing method

Applicant's Name : **SHENZHEN SAMHOO SCI&TECH CO.,LTD**

Address : Room 401, Building 2th, Huaqiangyun Industrial Park, Meixiu
Road, Meilin, Futian District, Shenzhen, China

Test Specification

Standard : FCC Part 90/FCC Part 2/FCC Part 15B

Test Report Form No. : LCSEMC-1.0

TRF Originator : Shenzhen LCS Compliance Testing Laboratory Ltd.

Master TRF : Dated 2011-03

Shenzhen LCS Compliance Testing Laboratory Ltd. All rights reserved.

This publication may be reproduced in whole or in part for non-commercial purposes as long as the Shenzhen LCS Compliance Testing Laboratory Ltd. is acknowledged as copyright owner and source of the material. Shenzhen LCS Compliance Testing Laboratory Ltd. takes no responsibility for and will not assume liability for damages resulting from the reader's interpretation of the reproduced material due to its placement and context.

Test Item Description. : **Digital Two Way Radio**

Trade Mark : Samhoo

Test Model : SPM6050

Ratings : DC 13.6V by External DC power supply

Result : **Positive**

Compiled by:

Aking Jin

Aking Jin/ File administrators

Supervised by:

Glin Lu

Glin Lu/ Technique principal

Approved by:

Gavin Liang

Gavin Liang/ Manager

RADIO -- TEST REPORT

Test Report No. : LCS1606130856E	<u>June 08, 2016</u> Date of issue
---	---------------------------------------

Test Model.....	: SPM6050
EUT.....	: Digital Two Way Radio
Applicant.....	: SHENZHEN SAMHOO SCI&TECH CO.,LTD
Address.....	: Room 401, Building 2th, Huaqiangyun Industrial Park, Meixiu Road, Meilin, Futian District, Shenzhen, China
Telephone.....	: /
Fax.....	: /
Manufacturer.....	: SHENZHEN SAMHOO SCI&TECH CO.,LTD
Address.....	: Room 401, Building 2th, Huaqiangyun Industrial Park, Meixiu Road, Meilin, Futian District, Shenzhen, China
Telephone.....	: /
Fax.....	: /
Factory.....	: SHENZHEN SAMHOO SCI&TECH CO.,LTD
Address.....	: Room 401, Building 2th, Huaqiangyun Industrial Park, Meixiu Road, Meilin, Futian District, Shenzhen, China
Telephone.....	: /
Fax.....	: /

Test Result	Positive
--------------------	-----------------

The test report merely corresponds to the test sample.
 It is not permitted to copy extracts of these test result without the written permission of the test laboratory.

Revision History

Revision	Issue Date	Revisions	Revised By
00	2016-06-08	Initial Issue	Gavin Liang

TABLE OF CONTENTS

1. GENERAL INFORMATION	6
1.1. PRODUCT DESCRIPTION FOR EQUIPMENT UNDER TEST (EUT)	6
1.2. OBJECTIVE	6
1.3. RELATED SUBMITTAL(S)/GRANT(S).....	6
1.4. DESCRIPTION OF TEST FACILITY	7
1.5. SUPPORT EQUIPMENT LIST	7
1.6. EXTERNAL I/O	7
1.7. MEASUREMENT UNCERTAINTY.....	7
1.8. TEST ENVIRONMENT	8
1.9. DESCRIPTION OF TEST MODES	8
2. SYSTEM TEST CONFIGURATION	9
2.1. JUSTIFICATION	9
2.2. EUT EXERCISE SOFTWARE	9
2.3. SPECIAL ACCESSORIES.....	9
2.4. BLOCK DIAGRAM/SCHEMATICS	9
2.5. EQUIPMENT MODIFICATIONS	9
2.6. CONFIGURATION OF TEST SETUP	9
3. SUMMARY OF TEST RESULT.....	10
4. TEST CONDITIONS AND RESULTS.....	11
4.1. CONDUCTED EMISSIONS TEST.....	11
4.2. OCCUPIED BANDWIDTH AND EMISSION MASK TEST.....	13
4.3. TRANSMITTER RADIATED SPURIOUS EMISSION	22
4.4. SPURIOUS EMISSION ON ANTENNA PORT	27
4.5. MODULATION CHARACTERISTICS	41
4.6. FREQUENCY STABILITY TEST.....	45
4.7. MAXIMUM TRANSMITTER POWER.....	47
4.8. TRANSMITTER FREQUENCY BEHAVIOR	54
5. LIST OF MEASURING EQUIPMENT.....	58

1. GENERAL INFORMATION

1.1. Product Description for Equipment Under Test (EUT)

EUT	: Digital Two Way Radio
Test Model	: SPM6050
Power Supply	: DC 13.6V by External DC power supply
Hardware Version	: SPM6000V4.0
Software Version	: V1.02.01.007
Frequency Range	: 450MHz-520MHz
Channel Separation	: Analog Voice 12.5KHz Digital Voice/Data 12.5KHz Digital Data 12.5KHz
Modulation Type	: FM for Analog Voice 4FSK for Digital Voice/Digital Data 4FSK for Digital Data
Emission Designator	: 11K0F3E for FM Modulation at 12.5KHz Channel Separation 7K60FXD for Digital Data only at 12.5KHz Channel Separation 7K60FXW for Digital Data & Digital Voice at 12.5KHz Channel Separation
Antenna Description	: External, 3.65dBi (Max)
Rated Power	: 45Wattes/5Watts
GPS Receiver	:
Receive Frequency	: 1575.42MHz
Channel Number	: 1

Note: The product has the same digital working characters when operating in both two digitized voice/data mode. So only one set of test results for digital modulation modes are provided in this test report.

1.2. Objective

The tests were performed according to following standards:

[FCC Rules Part 90: 2015](#): PRIVATE LAND MOBILE RADIO SERVICES.

[47 CFR FCC Part 15 Subpart B: 2015](#) - Unintentional Radiators

[FCC Part 2](#): FREQUENCY ALLOCA-TIONS AND RADIO TREATY MAT-TERS; GENERAL RULES AND REG-ULATIONS

[TIA/EIA 603 D: June 2014](#): Land Mobile FM or PM Communications Equipment Measurement and Performance Standards.

1.3. Related Submittal(s)/Grant(s)

No Related Submittals.

1.4. Description of Test Facility

CNAS Registration Number. is L4595.

FCC Registration Number. is 899208.

Industry Canada Registration Number. is 9642A-1.

VCCI Registration Number. is C-4260 and R-3804.

ESMD Registration Number. is ARCB0108.

UL Registration Number. is 100571-492.

TUV SUD Registration Number. is SCN1081.

TUV RH Registration Number. is UA 50296516-001

1.5. Support equipment List

Manufacturer	Description	Model	Serial Number	Certificate
--	--	--	--	--

1.6. External I/O

I/O Port Description	Quantity	Cable
Micro SD Card Slot	1	N/A
Handheld Microphone Interface	1	N/A
Accessories Interface	1	N/A
RF Antenna Base	1	N/A
Power Interface	1	N/A
Positioning Module Antenna Interface	1	N/A

1.7. Measurement Uncertainty

Where relevant, the following measurement uncertainty levels have been estimated for tests performed on the apparatus:

Test Items	Measurement Uncertainty	Notes
Frequency stability	30 Hz	(1)
Transmitter power conducted	0.62 dB	(1)
Transmitter power Radiated	2.67 dB	(1)
Conducted spurious emission 9KHz-40 GHz	1.88 dB	(1)
Conducted Emission 9KHz-30MHz	1.63 dB	(1)
Radiated Emission 30~1000MHz	4.65 dB	(1)
Radiated Emission 1~18GHz	3.89 dB	(1)
Radiated Emission 18-40GHz	3.90 dB	(1)
Occupied Bandwidth	-----	(1)
Emission Mask	-----	(1)
Modulation Characteristic	-----	(1)
Transmitter Frequency Behavior	-----	(1)

(1) This uncertainty represents an expanded uncertainty expressed at approximately the 95% confidence level using a coverage factor of k=1.96.

1.8. Test Environment

Items	Required (IEC 68-1)	Actual
Temperature (°C)	15-35	21
Humidity (%RH)	25-75	50
Barometric pressure (mbar)	860-1060	950-1000

1.9. Description Of Test Modes

The EUT has been tested under typical operating condition and The Transmitter was operated in the normal operating mode. The TX frequency was fixed which was for the purpose of the measurements.

EUT operation mode no.	Description of operation mode	Additional information
Op 1	FM+BW12.5KHz+TX	The equipment is set with FM modulation and 12.5KHz bandwidth at maximum rated power for transmitter, powered by DC 13.60V
Op 2	FM+BW12.5KHz+TX	The equipment is set with FM modulation and 12.5KHz bandwidth at minimum rated power for transmitter, powered by DC 13.60V
Op 3	4FSK+BW12.5KHz+TX	The equipment is set with 4FSK modulation and 12.5KHz bandwidth at maximum rated power for transmitter, powered by DC 13.60V
Op 4	4FSK+BW12.5KHz+TX	The equipment is set with 4FSK modulation and 12.5KHz bandwidth at minimum rated power for transmitter, powered by DC 13.60V
Op 5	FM+BW12.5KHz+RX (Standby)	The equipment is set with FM modulation and 12.5KHz bandwidth at Receiver/Standby mode, powered by DC 13.60V
Op 6	4FSK+BW12.5KHz+RX (Standby)	The equipment is set with 4FSK modulation and 12.5KHz bandwidth at Receiver/Standby mode, powered by DC 13.60V

Test frequency list

Modulation Type	Channel Separation	Test Channel	Test Frequency (MHz)	
			TX	RX
Analog/FM	12.5KHz	Ch1	450.025	450.025
		Ch2	467.775	467.775
		Ch3	511.9875	511.9875
Digital/4FSK	12.5KHz	Ch4	450.025	450.025
		Ch5	467.775	467.775
		Ch6	511.9875	511.9875

2. SYSTEM TEST CONFIGURATION

2.1. Justification

The system was configured for testing in engineering mode.

2.2. EUT Exercise Software

N/A.

2.3. Special Accessories

N/A.

2.4. Block Diagram/Schematics

Please refer to the related document.

2.5. Equipment Modifications

Shenzhen LCS Compliance Testing Laboratory Ltd. has not done any modification on the EUT.

2.6. Configuration of Test Setup

Please refer to the test setup photo.

3. SUMMARY OF TEST RESULT

Test specification clause	Test case	Verdict
FCC Part 15.107	AC Conducted Emission	N/A
FCC Part 90.205	Maximum Transmitter Power	PASS
FCC Part 90.207	Modulation Characteristic	PASS
FCC Part 90.209	Occupied Bandwidth	PASS
FCC Part 90.210	Emission Mask	PASS
FCC Part 90.213	Frequency Stability	PASS
FCC Part 90.214	Transmitter Frequency Behavior	PASS
FCC Part 90.210	Transmitter Radiated Spurious Emission	PASS
FCC Part 90.210	Spurious Emission On Antenna Port	PASS

Remark:

1. The measurement uncertainty is not included in the test result.
2. The sample was powered by DC 13.60V from battery, not need test AC conducted emission per 15.107

4. TEST CONDITIONS AND RESULTS

4.1. Conducted Emissions Test

TEST APPLICABLE

The EUT was tested according to ANSI C63.4 - 2014. The frequency spectrum from 0.15 MHz to 30 MHz was investigated. The LISN used was 50 ohm / 50 u Henry as specified by section 5.1 of ANSI C63.4 - 2014. Cables and peripherals were moved to find the maximum emission levels for each frequency.

TEST CONFIGURATION

For AC Power

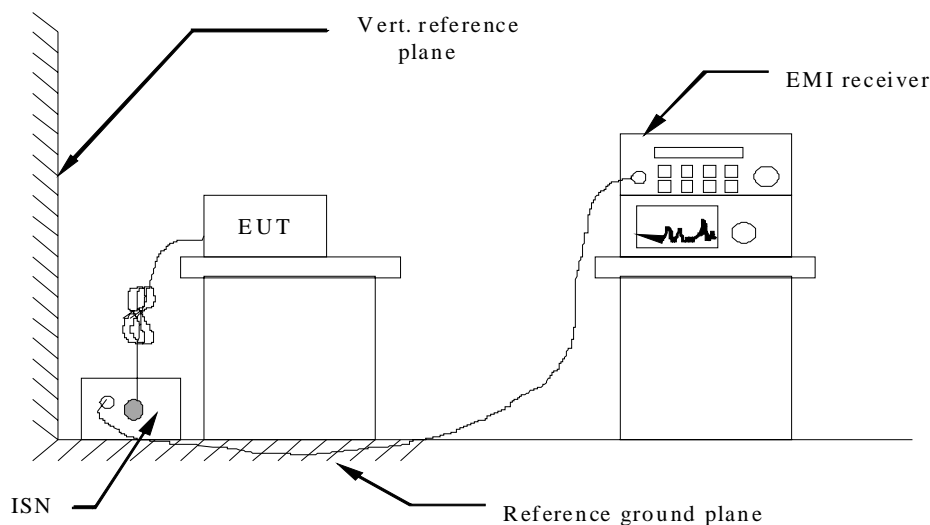

TEST PROCEDURE

- 1 The equipment was set up as per the test configuration to simulate typical actual usage per the user's manual. The EUT is a tabletop system; a wooden table with a height of 0.8 meters is used and is placed on the ground plane as per ANSI C63.4-2014.
- 2 Support equipment, if needed, was placed as per ANSI C63.4-2014.
- 3 All I/O cables were positioned to simulate typical actual usage as per ANSI C63.4-2014.
- 4 If a EUT received AC120V/60Hz power through a Line Impedance Stabilization Network (LISN) which supplied power source and was grounded to the ground plane.
- 5 If a EUT received DC 13.60V power through an Impedance Stabilization Network (ISN) which supplied power source and was grounded to the ground plane.
- 6 All support equipments received AC power from a second LISN, if any.
- 7 The EUT test program was started. Emissions were measured on each current carrying line of the EUT using a spectrum Analyzer / Receiver connected to the LISN powering the EUT. The LISN has two monitoring points: Line 1 (Hot Side) and Line 2 (Neutral Side). Two scans were taken: one with Line 1 connected to Analyzer / Receiver and Line 2 connected to a 50 ohm load; the second scan had Line 1 connected to a 50 ohm load and Line 2 connected to the Analyzer / Receiver.
- 8 Analyzer / Receiver scanned from 150 KHz to 30MHz for emissions in each of the test modes.
- 9 During the above scans, the emissions were maximized by cable manipulation.

Conducted Power Line Emission Limit

For intentional device, according to § 15.207(a) and RSS-Gen Section 7.2.4 for DC Power Conducted Emission Limits is as following:

Frequency (MHz)	Maximum RF Line Voltage (dB μ V)			
	CLASS A		CLASS B	
	Q.P.	Ave.	Q.P.	Ave.
0.15 - 0.50	79	66	66-56*	56-46*
0.50 - 5.00	73	60	56	46
5.00 - 30.0	73	60	60	50

* Decreasing linearly with the logarithm of the frequency

TEST RESULTS

Not applicable (The sample was powered by DC 13.60V from battery)

4.2. Occupied Bandwidth and Emission Mask Test

TEST APPLICABLE

- (a). Occupied Bandwidth: The EUT was connected to the audio signal generator and the spectrum analyzer via the main RF connector, and through an appropriate attenuator. The EUT was controlled to transmit its maximum power. Then the bandwidth of 99% power can be measured by the spectrum analyzer.
- (b). Emission Mask B: For transmitters that are equipped with an audio low-pass filter pursuant to §90.211(a), the power of any emission must be below the unmodulated carrier power (P) as follows:
- (1) On any frequency removed from the assigned frequency by more than 50 percent, but not more than 100 percent of the authorized bandwidth: At least 25 dB.
 - (2) On any frequency removed from the assigned frequency by more than 100 percent, but not more than 250 percent of the authorized bandwidth: At least 35 dB.
 - (3) On any frequency removed from the assigned frequency by more than 250 percent of the authorized bandwidth: At least $43 + 10 \log (P)$ dB.
- (c). Emission Mask D, 12.5 kHz channel bandwidth equipment: For transmitters designed to operate with a 12.5 kHz channel bandwidth, any emission must be attenuated below the power (P) of the highest emission contained within the authorized bandwidth as follows:
- (1) On any frequency from the centre of the authorized bandwidth f_0 to 5.625 kHz removed from f_0 : Zero dB.
 - (2) On any frequency removed from the centre of the authorized bandwidth by a displacement frequency (f_d in kHz) of more than 5.625 kHz but no more than 12.5 kHz: At least $7.27(f_d - 2.88 \text{ kHz})$ dB.
 - (3) On any frequency removed from the centre of the authorized bandwidth by a displacement frequency (f_d in kHz) of more than 12.5 kHz: At least $50 + 10 \log (P)$ dB or 70 dB, whichever is the lesser attenuation.

TEST CONFIGURATION

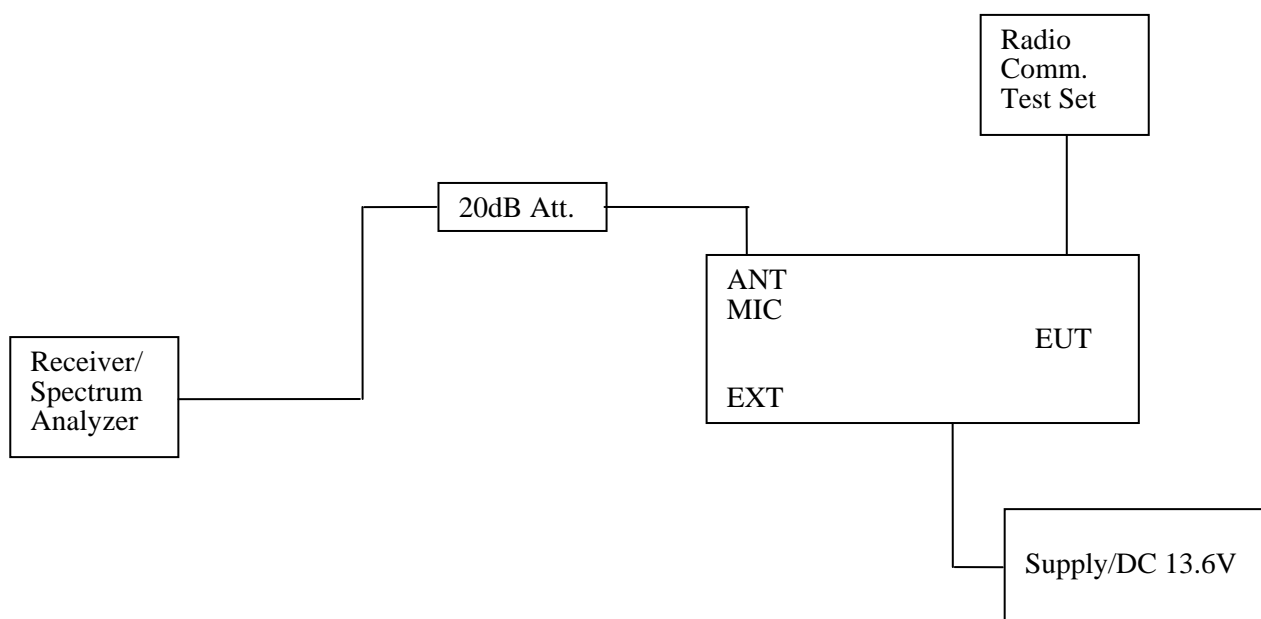

TEST PROCEDURE

- 1 The EUT was placed on a turn table which is 0.8m above ground plane.
- 2 The EUT was modulated by 2.5 KHz Sine wave audio signal; the level of the audio signal employed is 16 dB greater than that necessary to produce 50% of rated system deviation. Rated system deviation is 2.5 kHz (12.5 kHz channel spacing).
- 3 Set EUT as normal operation.
- 4 Set SPA Centre Frequency = fundamental frequency, RBW=300Hz, VBW= 3 KHz, span =50 KHz.
- 5 Set SPA Max hold. Mark peak, Set 99% Occupied Bandwidth and 26dB Occupied Bandwidth.
- 6 Set SPA Centre Frequency=fundamental frequency, set =300Hz, VBW=1 KHz, span=50 KHz for 12.5 KHz channel spacing.

TEST RESULTS

Remark: We tested Op 1 to Op 4, recorded worst case at Op 1 and Op 3.

4.2.1 Occupied Bandwidth

Modulation Type	Channel Separation	Operation Mode	Test Channel	Test Frequency (MHz)	Occupied Bandwidth (KHz)	
					99%	26dB
Analog/FM	12.5KHz	Op 1	Ch1	450.025	5.83	10.43
			Ch2	467.775	5.77	10.41
			Ch3	511.9875	5.63	10.32
Digital/4FSK	12.5KHz	Op 3	Ch7	450.025	7.46	9.48
			Ch8	467.775	7.33	9.42
			Ch9	511.9875	7.51	9.80
Limit			11.25KHz for 12.5KHz Channel Separation			
Test Results			PASS			

Plots of 99% and 26dB Bandwidth Measurement

Modulation Type	Channel Separation	Operation Mode	Test Channel	Test Frequency (MHz)	Occupied Bandwidth (KHz)		Limit (KHz)	Results
					99%	26dB		
FM	12.5 KHz	Op 1	Ch1	450.025	5.83	10.43	11.25	PASS

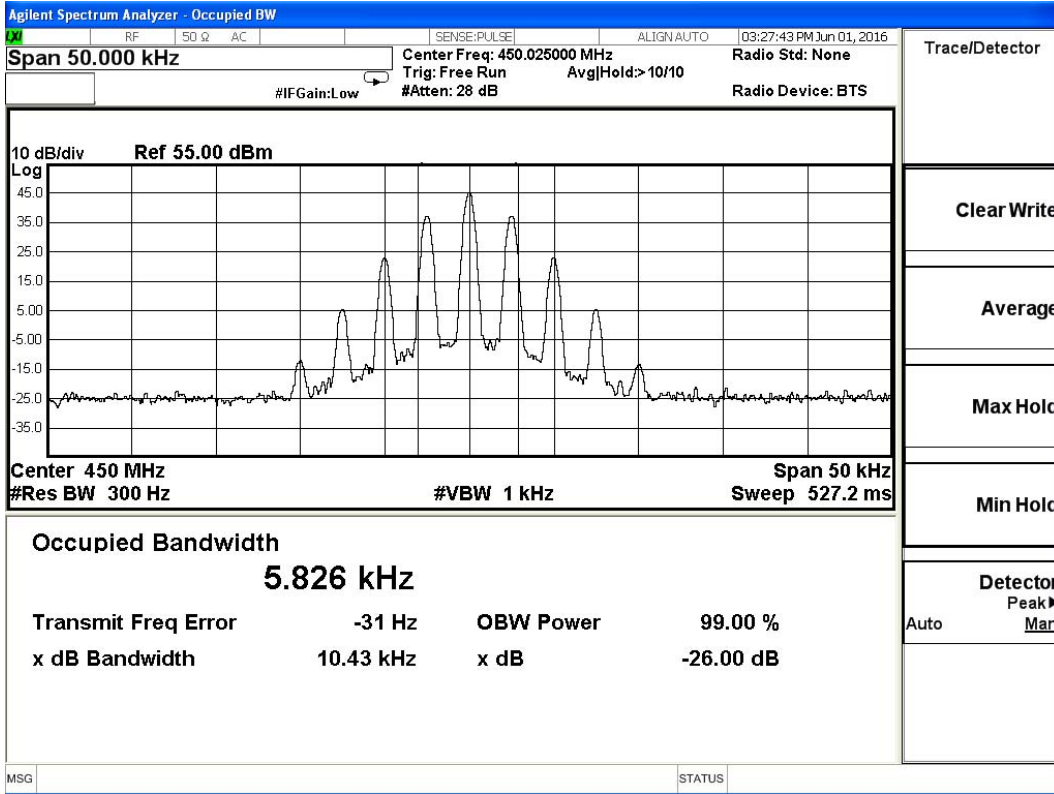

Modulation Type	Channel Separation	Operation Mode	Test Channel	Test Frequency (MHz)	Occupied Bandwidth (KHz)		Limit (KHz)	Results
					99%	26dB		
FM	12.5 KHz	Op 1	Ch2	467.775	5.77	10.41	11.25	PASS

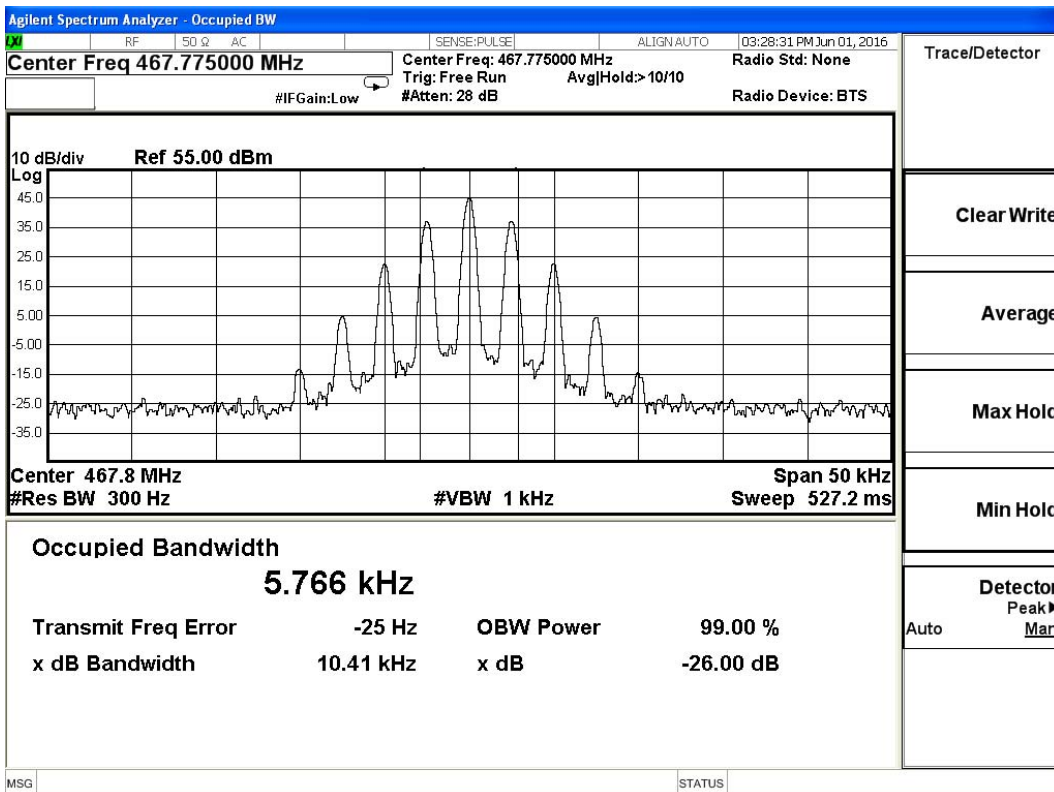

Modulation Type	Channel Separation	Operation Mode	Test Channel	Test Frequency (MHz)	Occupied Bandwidth (KHz)		Limit (KHz)	Results
					99%	26dB		
FM	12.5 KHz	Op 1	Ch3	511.9875	5.63	10.32	11.25	PASS

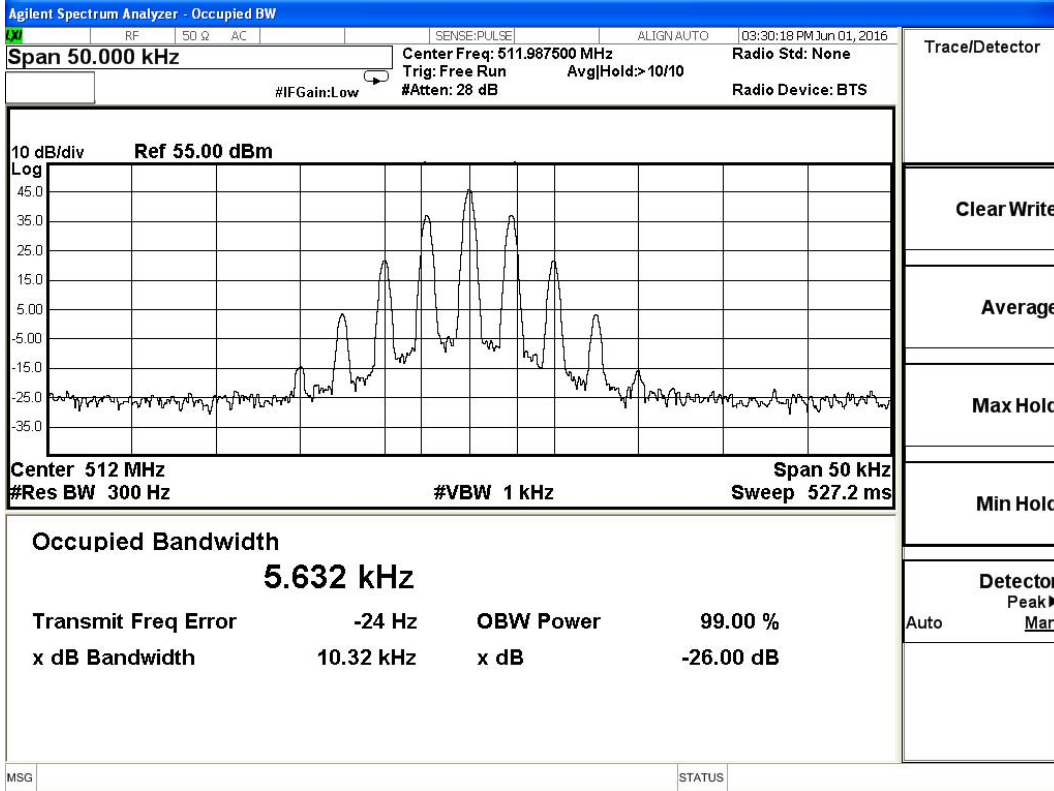

Modulation Type	Channel Separation	Operation Mode	Test Channel	Test Frequency (MHz)	Occupied Bandwidth (KHz)		Limit (KHz)	Results
					99%	26dB		
4FSK	12.5 KHz	Op 3	Ch7	450.025	7.46	9.48	11.25	PASS

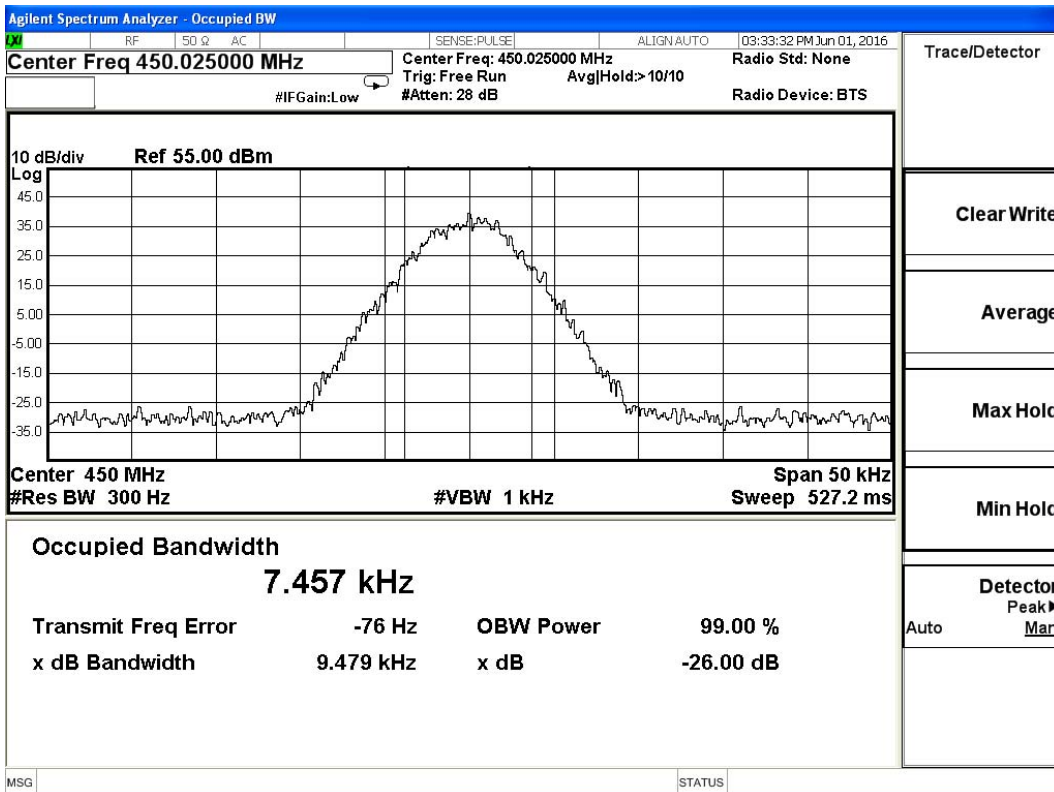

Modulation Type	Channel Separation	Operation Mode	Test Channel	Test Frequency (MHz)	Occupied Bandwidth (KHz)		Limit (KHz)	Results
					99%	26dB		
4FSK	12.5 KHz	Op 3	Ch8	467.775	7.33	9.42	11.25	PASS

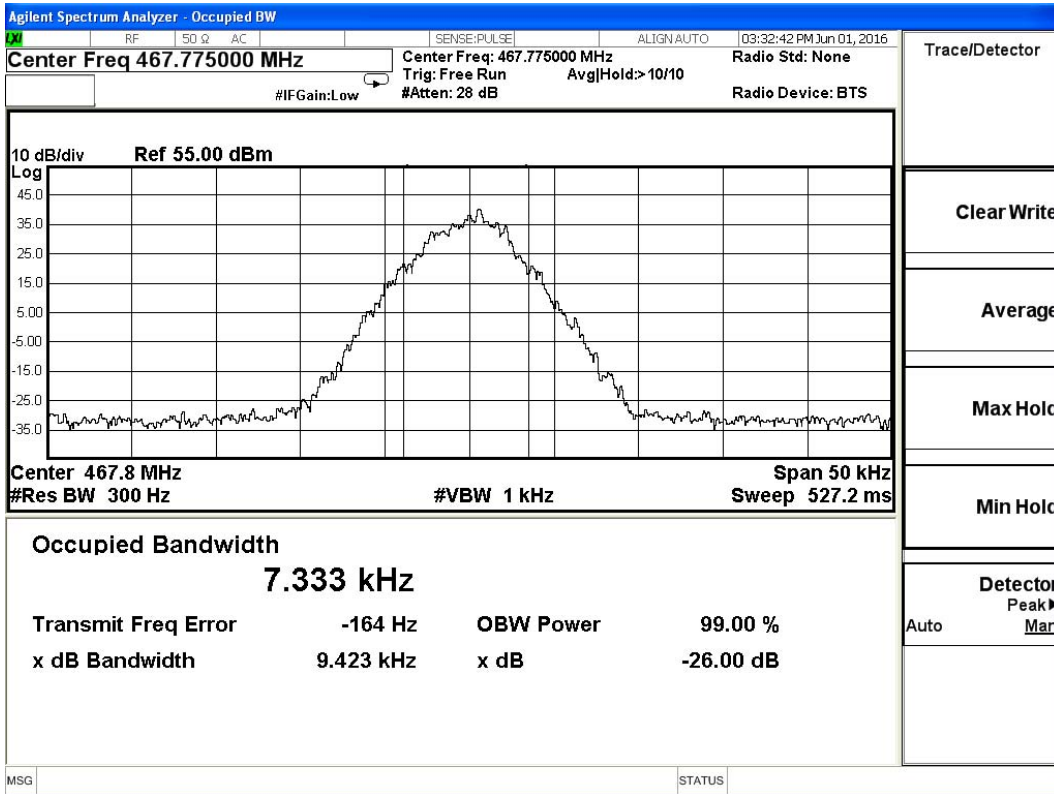

Modulation Type	Channel Separation	Operation Mode	Test Channel	Test Frequency (MHz)	Occupied Bandwidth (KHz)		Limit (KHz)	Results
					99%	26dB		
4FSK	12.5 KHz	Op 3	Ch9	511.9875	7.51	9.80	11.25	PASS

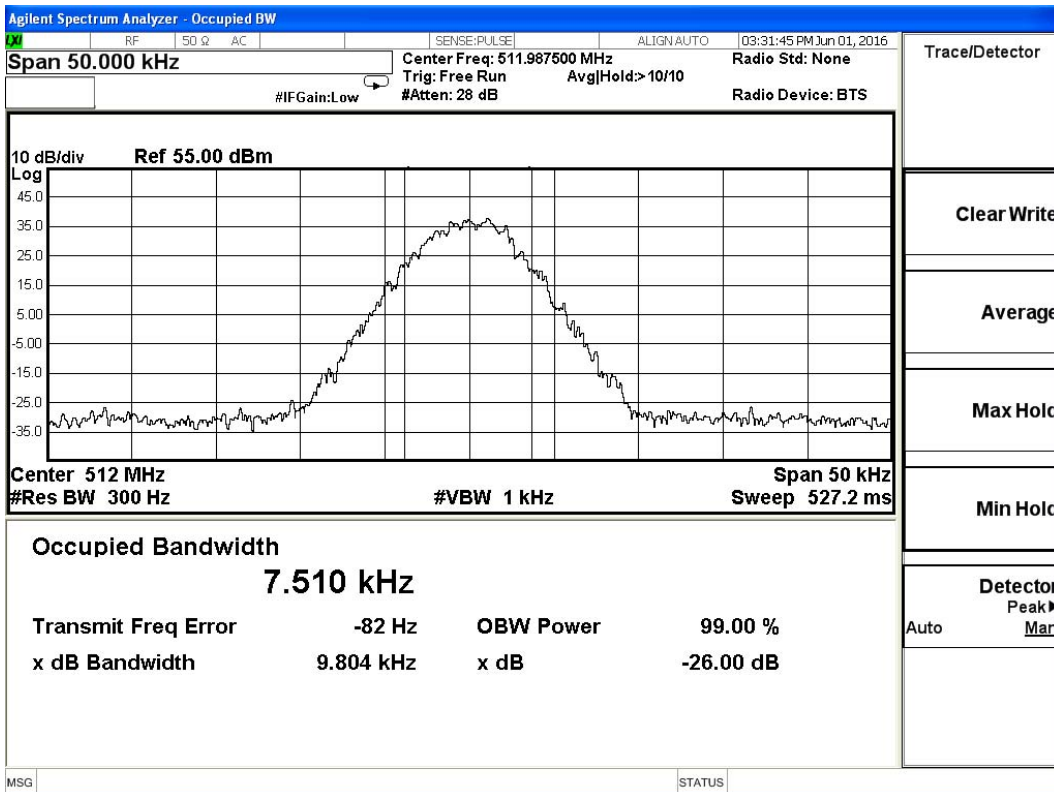

4.2.2 Emission Mask

Modulation Type	Channel Separation	Operation Mode	Test Channel	Test Frequency (MHz)	Applicable Mask	RBW (Hz)
Analog/FM	12.5 KHz	Op 1	Ch1	450.025	D	300
			Ch2	467.775	D	300
			Ch3	511.9875	D	300
Digital/4FSK	12.5 KHz	Op 3	Ch7	450.025	D	300
			Ch8	467.775	D	300
			Ch9	511.9875	D	300
Test Results				PASS		

Plots of Emission Mask Measurement

Referred as the attached plot hereinafter

Note: The Black curve represents unmodulated signal.
The Blue curve represents modulated signal.

Modulation Type	Channel Separation	Operation Mode	Test Channel	Test Frequency (MHz)	Applicable Mask	RBW (Hz)	Audio Freq. (KHz)	Results
FM	12.5KHz	Op 1	Ch1	450.025	D	300	2.5	PASS

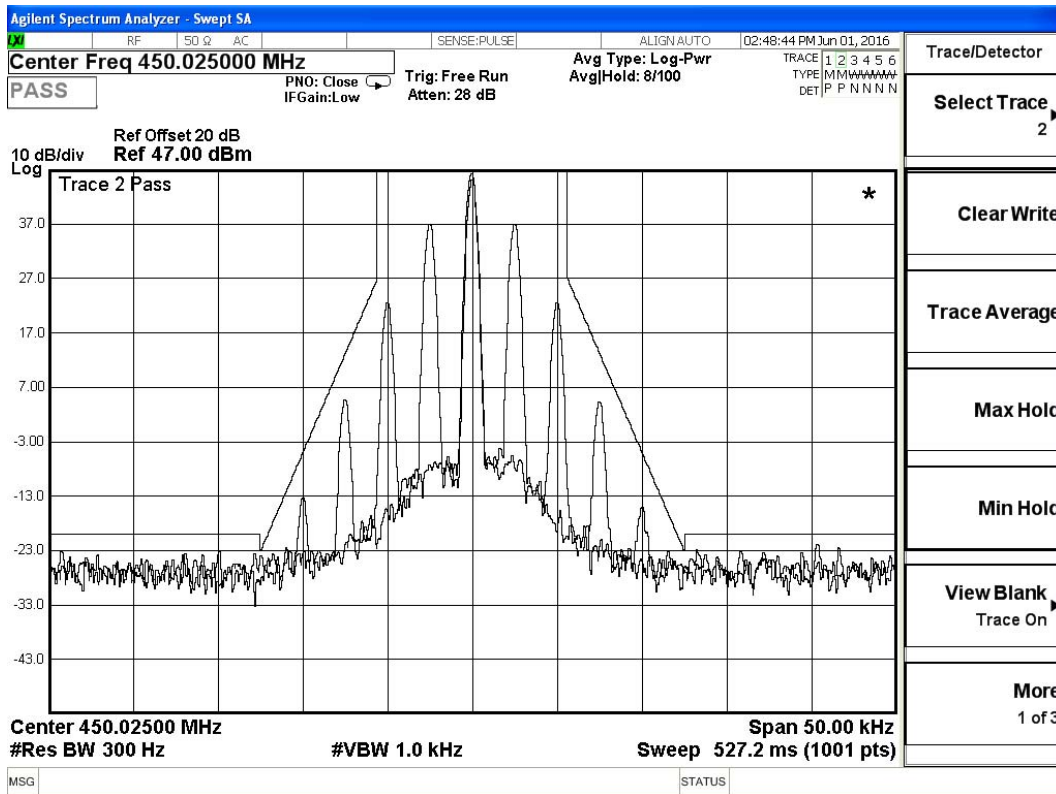

Modulation Type	Channel Separation	Operation Mode	Test Channel	Test Frequency (MHz)	Applicable Mask	RBW (Hz)	Audio Freq. (KHz)	Results
FM	12.5KHz	Op 1	Ch2	467.775	D	300	2.5	PASS

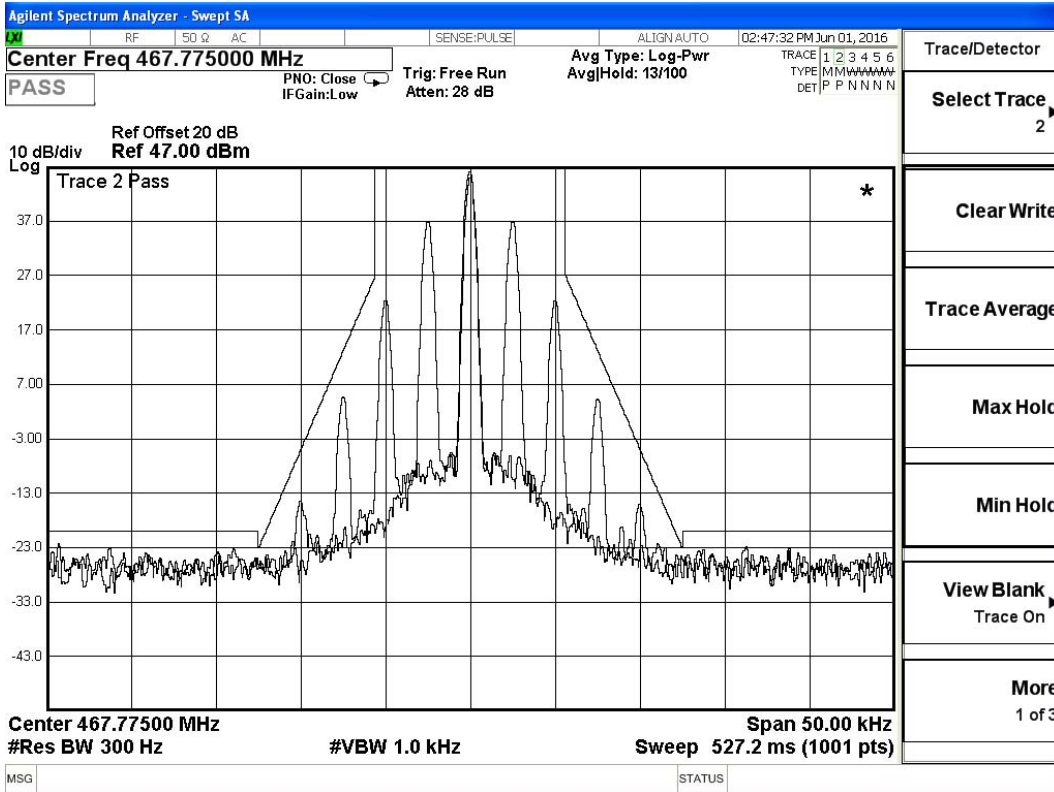

Modulation Type	Channel Separation	Operation Mode	Test Channel	Test Frequency (MHz)	Applicable Mask	RBW (Hz)	Audio Freq. (KHz)	Results
FM	12.5KHz	Op 1	Ch3	511.9875	D	300	2.5	PASS

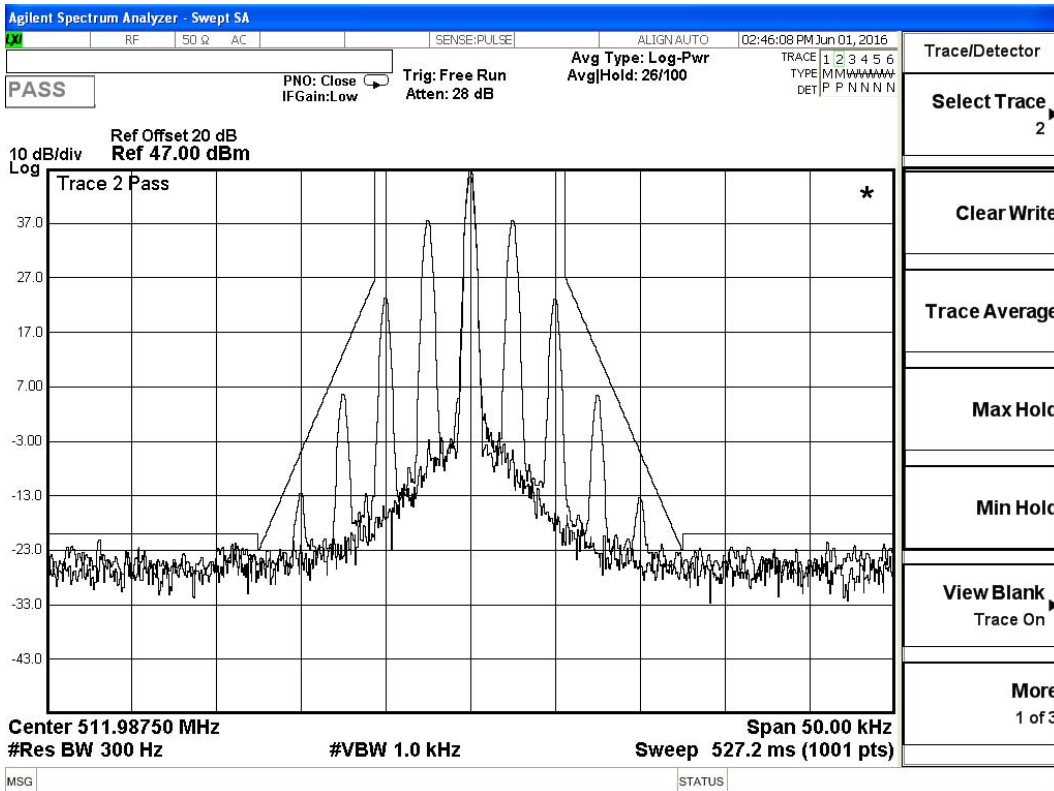

Modulation Type	Channel Separation	Operation Mode	Test Channel	Test Frequency (MHz)	Applicable Mask	RBW (Hz)	Audio Freq. (KHz)	Results
4FSK	12.5KHz	Op 3	Ch7	450.025	D	300	/	PASS

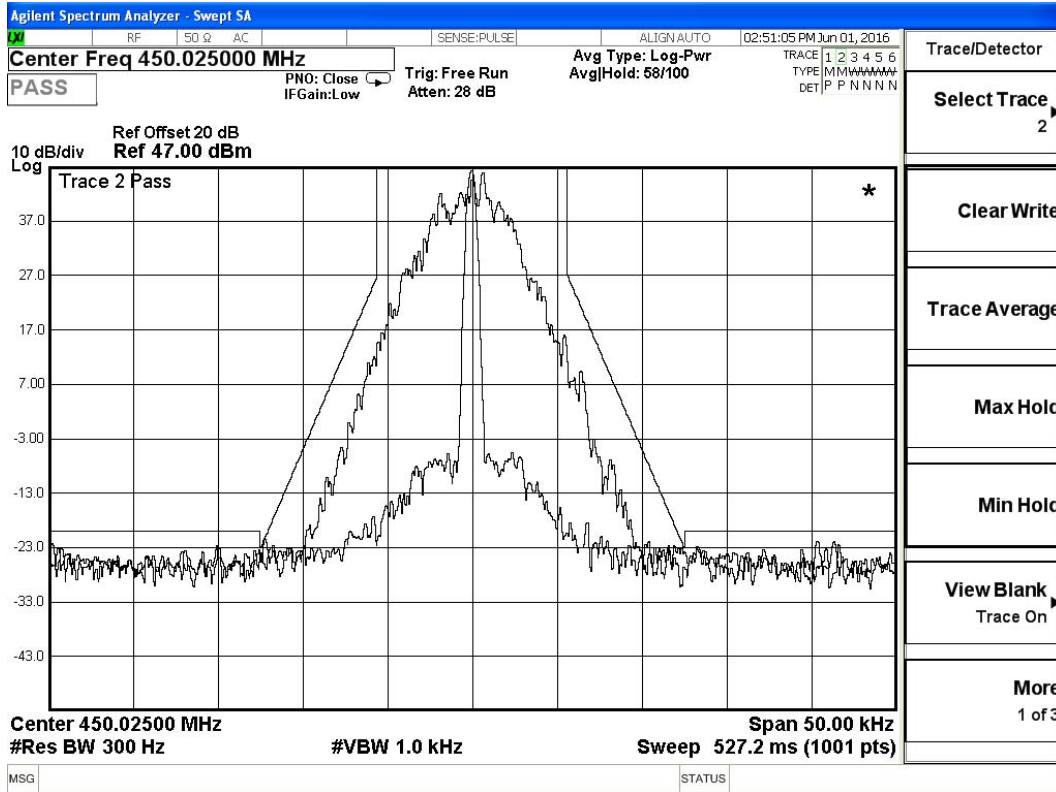

Modulation Type	Channel Separation	Operation Mode	Test Channel	Test Frequency (MHz)	Applicable Mask	RBW (Hz)	Audio Freq. (KHz)	Results
4FSK	12.5KHz	Op 3	Ch8	467.775	D	300	1	PASS

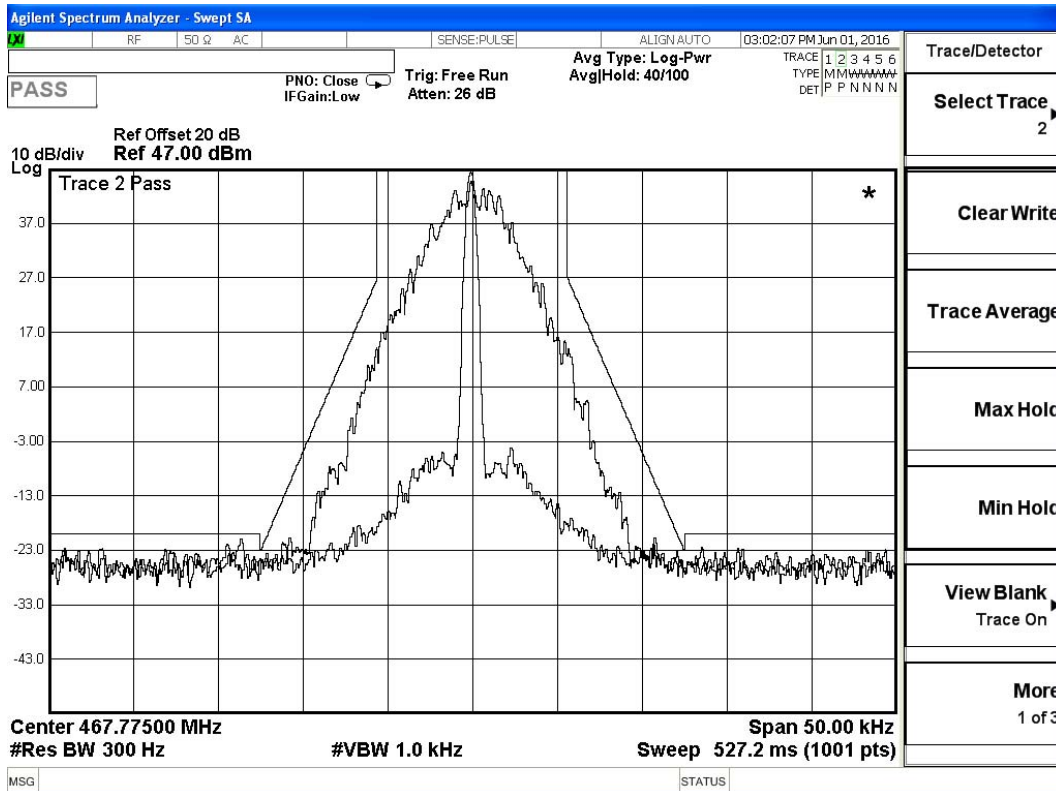

Modulation Type	Channel Separation	Operation Mode	Test Channel	Test Frequency (MHz)	Applicable Mask	RBW (Hz)	Audio Freq. (KHz)	Results
4FSK	12.5KHz	Op 3	Ch9	511.9875	D	300	/	PASS

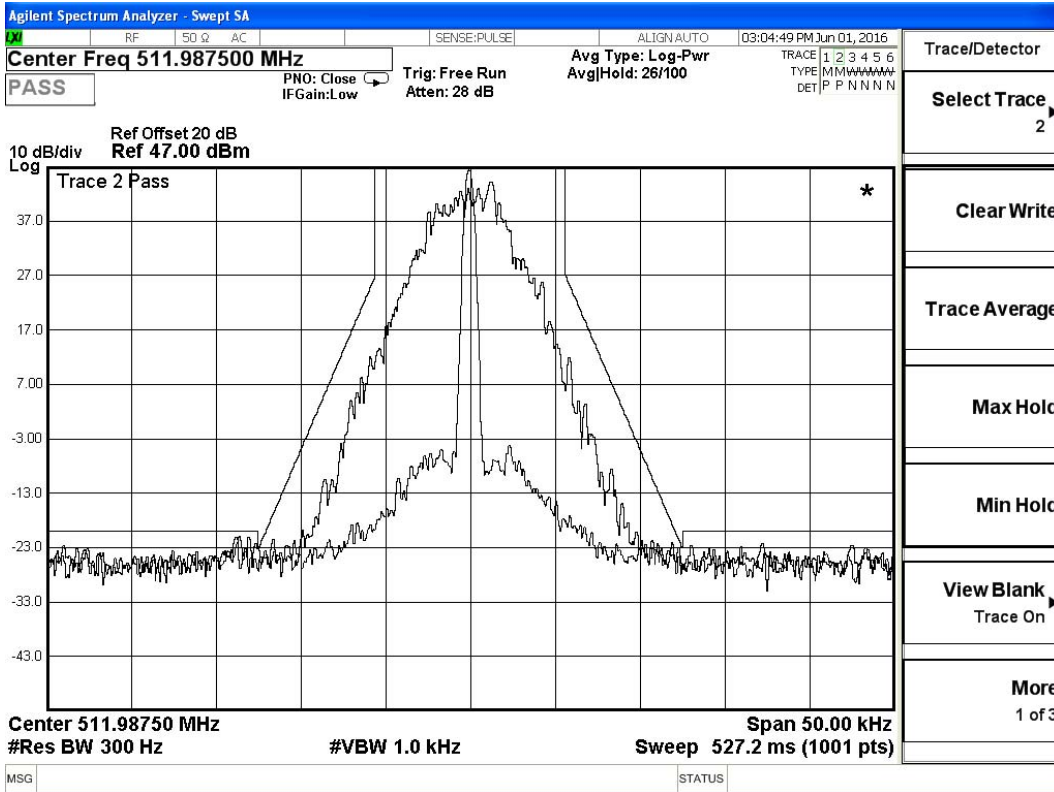

4.3. Transmitter Radiated Spurious Emission

TEST APPLICABLE

According to the TIA/EIA 603 test method, and according to Section 90.210, the power of each unwanted emission shall be less than Transmitted Power as specified below for transmitters designed to operate with 12.5 KHz channel bandwidth:

- 1 On any frequency removed from the centre of the authorized bandwidth f_0 to 5.625 KHz removed from f_0 : Zero dB
- 2 On any frequency removed from the centre of the authorized bandwidth by a displacement frequency (f_d in KHz) f_0 of more than 5.625 KHz but no more than 12.5 KHz: At least 7.27dB
- 3 On any frequency removed from the centre of the authorized bandwidth by a displacement frequency (f_d in KHz) f_0 of more than 12.5 KHz: At least $50+10 \log (P)$ dB or 70 dB, which ever is lesser attenuation.

For transmitters designed to transmit with 25 KHz channel separation and equipped with an audio low-pass filter, the power of any emission must be attenuated below the unmodulated carrier power (P) as following:

- 1 On any frequency removed from the assigned frequency by more than 50 percent, but no more than 100 percent of the authorized bandwidth: At least 25 dB.
- 2 On any frequency removed from the assigned frequency by more than 100 percent, but no more than 250 percent of the authorized bandwidth: At least 35 dB.
- 3 On any frequency removed from the assigned frequency by more than 250 percent of the authorized bandwidth: At least $43+10\text{Log} (P)$ dB.

TEST CONFIGURATION

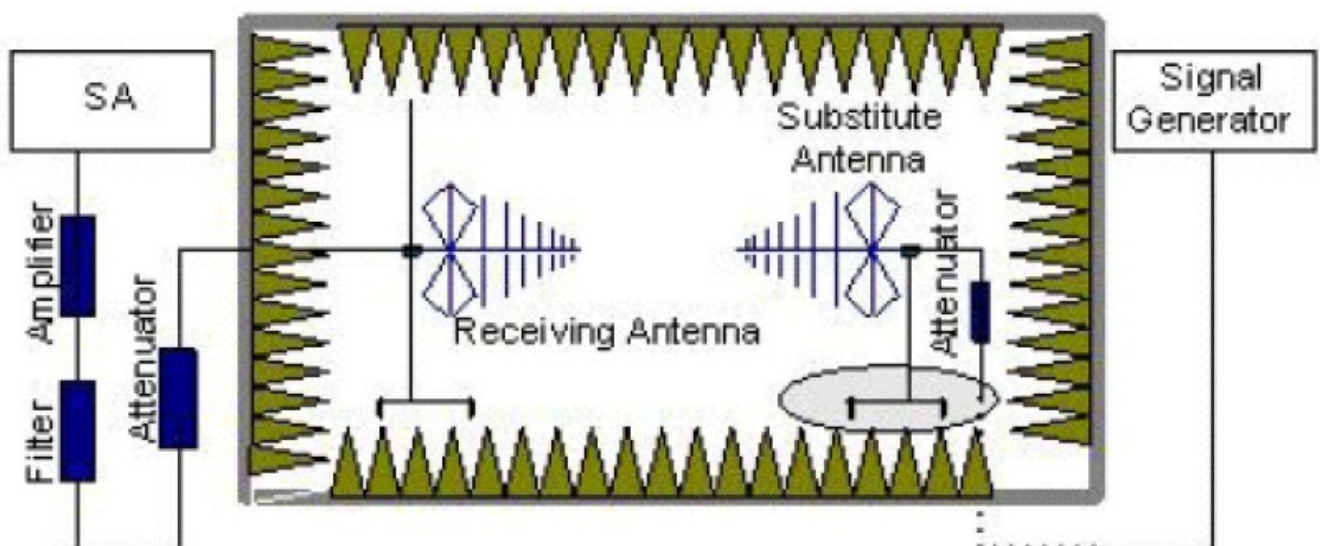

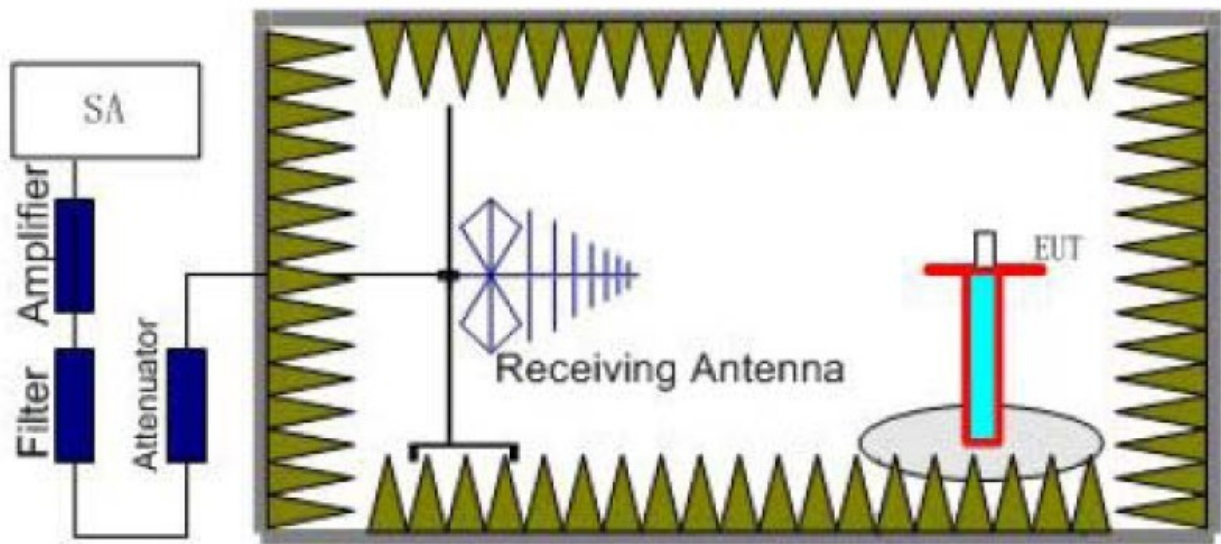

TEST PROCEDURE

1. EUT was placed on a 1.50 meter high non-conductive stand at a 3 meter test distance from the receive antenna. A receiving antenna was placed on the antenna mast 3 meters from the EUT for emission measurements. The height of receiving antenna is 1.50 m. Detected emissions were maximized at each frequency by rotating the EUT through 360° and adjusting the receiving antenna polarization. The radiated emission measurements of all transmit frequencies in six channels were measured with peak detector.
2. A log-periodic antenna or double-ridged waveguide horn antenna shall be substituted in place of the EUT. The log-periodic antenna will be driven by a signal generator and the level will be adjusted till the same power value on the spectrum analyzer or receiver. The level of the spurious emissions can be calculated through the level of the signal generator, cable loss, the gain of the substitution antenna and the reading of the spectrum analyzer or receiver.
3. The EUT is then put into continuously transmitting mode at its maximum power level during the test. Set Test Receiver or Spectrum RBW=1MHz, VBW=3MHz for above 1GHz and RBW=100 KHz, VBW=300 KHz for 30MHz to 1GHz, and the maximum value of the receiver should be recorded as (P_r).
4. The EUT shall be replaced by a substitution antenna. In the chamber, a substitution antenna for the frequency band of interest is placed at the reference point of the chamber. An RF Signal source for the frequency band of interest is connected to the substitution antenna with a cable that has been constructed to not interfere with the radiation pattern of the antenna. A power (P_{Mea}) is applied to the input of the substitution antenna, and adjust the level of the signal generator output until the value of the receiver reach the previously recorded (P_r). The power of signal source (P_{Mea}) is recorded. The test should be performed by rotating the test item and adjusting the receiving antenna polarization.
5. An amplifier should be connected to the Signal Source output port. And the cable should be connect between the Amplifier and the Substitution Antenna. The cable loss (P_{cl}), the Substitution Antenna Gain (G_a) and the Amplifier Gain (P_{Ag}) should be recorded after test. The measurement results are obtained as described below:
 Power (EIRP) = $P_{Mea} - P_{Ag} - P_{cl} - G_a$
 Amplifier for substitution test;
 The measurement results are amending as described below:
 Power (EIRP) = $P_{Mea} - P_{cl} - G_a$

6. This value is EIRP since the measurement is calibrated using an antenna of known gain (2.15 dBi) and known input power.
7. ERP can be calculated from EIRP by subtracting the gain of the dipole, $ERP = EIRP - 2.15 \text{ dBi}$.

LIMIT

Modulation Type: FM

FCC Part 22.359, 74.462, 80.211 and 90.210 and RSS Gen, RSS 119 Issue 12:

For 12.5 kHz bandwidth:

On any frequency removed from the center of the authorized bandwidth by a displacement frequency (f_d in kHz) of more than 12.5 kHz at least:

High: $50 + 10 \log(P_{\text{watts}}) = 50 + 10 \log(45.0) = 66.53 \text{ dB}$

Low: $50 + 10 \log(P_{\text{watts}}) = 50 + 10 \log(5.0) = 56.99 \text{ dB}$

Note: In general, the worst case attenuation requirement shown above was applied.

Calculation: Limit (dBm) = $EL - 50 - 10 \log_{10}(TP)$

Notes: EL is the emission level of the Output Power expressed in dBm,

In this application, the EL is 46.53 dBm for Rated High power level and 37.02 dBm for Rated Lower power level;

High: Limit (dBm) = $46.53 - 50 - 10 \log_{10}(45.0) = -20 \text{ dBm}$

Low: Limit (dBm) = $37.02 - 50 - 10 \log_{10}(5.0) = -20 \text{ dBm}$

Modulation Type: 4FSK

FCC Part 22.359, 74.462, 80.211 and 90.210 and RSS Gen, RSS 119 Issue 12 (12.5 kHz Bandwidth only):

On any frequency removed from the center of the authorized bandwidth by a displacement frequency (f_d in kHz) of more than 12.5 kHz at least:

High: $50 + 10 \log(P_{\text{watts}}) = 50 + 10 \log(45.0) = 66.53 \text{ dB}$

Low: $50 + 10 \log(P_{\text{watts}}) = 50 + 10 \log(5.0) = 56.99 \text{ dB}$

Note: In general, the worst case attenuation requirement shown above was applied.

Calculation: Limit (dBm) = $EL - 50 - 10 \log_{10}(TP)$

Notes: EL is the emission level of the Output Power expressed in dBm,

In this application, the EL is 46.53 dBm for Rated High power level and 37.02 dBm for Rated Lower power level;

High: Limit (dBm) = $46.53 - 50 - 10 \log_{10}(45.0) = -20 \text{ dBm}$

Low: Limit (dBm) = $37.02 - 50 - 10 \log_{10}(5.0) = -20 \text{ dBm}$

Note:

1. In general, the worse case attenuation requirement shown above was applied.
2. The measurement frequency range from 30 MHz to 6 GHz.
3. *** means that the emission level is too low to be measured or at least 20 dB down than the limit.
4. Radiated spurious tested ERP for below 1GHz and EIRP for above 1GHz.

TEST RESULTS

Remark:

We tested Op 1 to Op 4, recorded worst case at *Op 1 and Op 3*.

Modulation Type: FM							
Operation Mode: Op 1				Channel Separation:12.5KHz			
Test Channel: Ch1				Test Frequency:450.025MHz			
Frequency (MHz)	P _{Mea} (dBm)	Path Loss	Antenna Gain	Correction (dB)	Peak EIRP(dBm)	Limit (dBm)	Polarization
900.050	-51.81	0.87	6.42	2.15	-48.41	-20.00	H
1350.075	-46.38	1.02	7.35	2.15	-42.20	-20.00	H
2250.125	-58.55	1.10	8.26	2.15	-53.54	-20.00	H
...	H
900.050	-51.53	0.87	6.42	2.15	-48.13	-20.00	V
1350.075	-46.88	1.02	7.35	2.15	-42.70	-20.00	V
2250.125	-57.19	1.10	8.26	2.15	-52.18	-20.00	V
...	V

Modulation Type: FM							
Operation Mode: Op 1				Channel Separation:12.5KHz			
Test Channel: Ch2				Test Frequency: 467.775MHz			
Frequency (MHz)	P _{Mea} (dBm)	Path Loss	Antenna Gain	Correction (dB)	Peak EIRP(dBm)	Limit (dBm)	Polarization
935.550	-52.70	0.92	6.80	2.15	-48.97	-20.00	H
1403.325	-44.89	1.06	7.89	2.15	-40.21	-20.00	H
2338.875	-60.98	1.12	8.12	2.15	-56.13	-20.00	H
...	H
935.550	-52.53	0.92	6.80	2.15	-48.80	-20.00	V
1403.325	-45.18	1.06	7.89	2.15	-40.50	-20.00	V
2338.875	-61.36	1.12	8.12	2.15	-56.51	-20.00	V
...	V

Modulation Type: FM							
Operation Mode: Op 1				Channel Separation:12.5KHz			
Test Channel: Ch3				Test Frequency: 511.9875MHz			
Frequency (MHz)	P _{Mea} (dBm)	Path Loss	Antenna Gain	Correction (dB)	Peak EIRP(dBm)	Limit (dBm)	Polarization
1023.9750	-53.71	0.95	6.80	2.15	-50.01	-20.00	H
1535.9625	-44.71	1.10	7.91	2.15	-40.05	-20.00	H
2559.9375	-59.86	1.21	8.25	2.15	-54.97	-20.00	H
...	H
1023.9750	-53.54	0.95	6.80	2.15	-49.84	-20.00	V
1535.9625	-41.72	1.10	7.91	2.15	-37.06	-20.00	V
2559.9375	-60.27	1.21	8.25	2.15	-55.38	-20.00	V
...	V

Modulation Type: 4FSK							
Operation Mode: Op 3				Channel Separation:12.5KHz			
Test Channel: Ch7				Test Frequency:450.025MHz			
Frequency (MHz)	P _{Mea} (dBm)	Path Loss	Antenna Gain	Correction (dB)	Peak EIRP(dBm)	Limit (dBm)	Polarization
900.050	-50.51	0.87	6.42	2.15	-47.11	-20.00	H
1350.075	-46.07	1.02	7.35	2.15	-41.89	-20.00	H
2250.125	-60.16	1.10	8.26	2.15	-55.15	-20.00	H
...	H
900.050	-52.37	0.87	6.42	2.15	-48.97	-20.00	V
1350.075	-45.52	1.02	7.35	2.15	-41.34	-20.00	V
2250.125	-60.51	1.10	8.26	2.15	-55.50	-20.00	V
900.050	V

Modulation Type: 4FSK							
Operation Mode: Op 3				Channel Separation:12.5KHz			
Test Channel: Ch8				Test Frequency: 467.775MHz			
Frequency (MHz)	P _{Mea} (dBm)	Path Loss	Antenna Gain	Correction (dB)	Peak EIRP(dBm)	Limit (dBm)	Polarization
935.550	-51.80	0.92	6.80	2.15	-48.07	-20.00	H
1403.325	-44.60	1.06	7.89	2.15	-39.92	-20.00	H
2338.875	-59.56	1.12	8.12	2.15	-54.71	-20.00	H
...	H
935.550	-52.79	0.92	6.80	2.15	-49.06	-20.00	V
1403.325	-44.95	1.06	7.89	2.15	-40.27	-20.00	V
2338.875	-60.94	1.12	8.12	2.15	-56.09	-20.00	V
...	V

Modulation Type: 4FSK							
Operation Mode: Op 3				Channel Separation:12.5KHz			
Test Channel: Ch9				Test Frequency: 511.9875MHz			
Frequency (MHz)	P _{Mea} (dBm)	Path Loss	Antenna Gain	Correction (dB)	Peak EIRP(dBm)	Limit (dBm)	Polarization
1023.9750	-53.03	0.95	6.80	2.15	-49.33	-20.00	H
1535.9625	-42.49	1.10	7.91	2.15	-37.83	-20.00	H
2559.9375	-58.94	1.21	8.25	2.15	-54.05	-20.00	H
...	H
1023.9750	-53.87	0.95	6.80	2.15	-50.17	-20.00	V
1535.9625	-44.81	1.10	7.91	2.15	-40.15	-20.00	V
2559.9375	-63.65	1.21	8.25	2.15	-58.76	-20.00	V
...	V

4.4. Spurious Emission on Antenna Port

TEST APPLICABLE

The same as Section 4.3

TEST PROCEDURE

The RF output of the EUT was connected to a spectrum analyzer through appropriate attenuation. The resolution bandwidth of the spectrum analyzer was set to 100 kHz. Sufficient scans were taken to show any out of band emission up to 10th. Harmonic for the lower and the highest frequency range. Set RBW=1KHz/VBW=3KHz in the frequency band 9KHz to 150KHz, RBW=10KHz/VBW=30 KHz in the frequency band 150KHz to 30 MHz, RBW=100 kHz/VBW=300 kHz in the frequency band 30MHz to 1GHz, and RBW=1MHz/VBW=3MHz from the 1GHz to 10th Harmonic.

The audio input was set to 0 to get the unmodulated carrier, the resulting picture is print out for each channel separation.

TEST CONFIGURATION

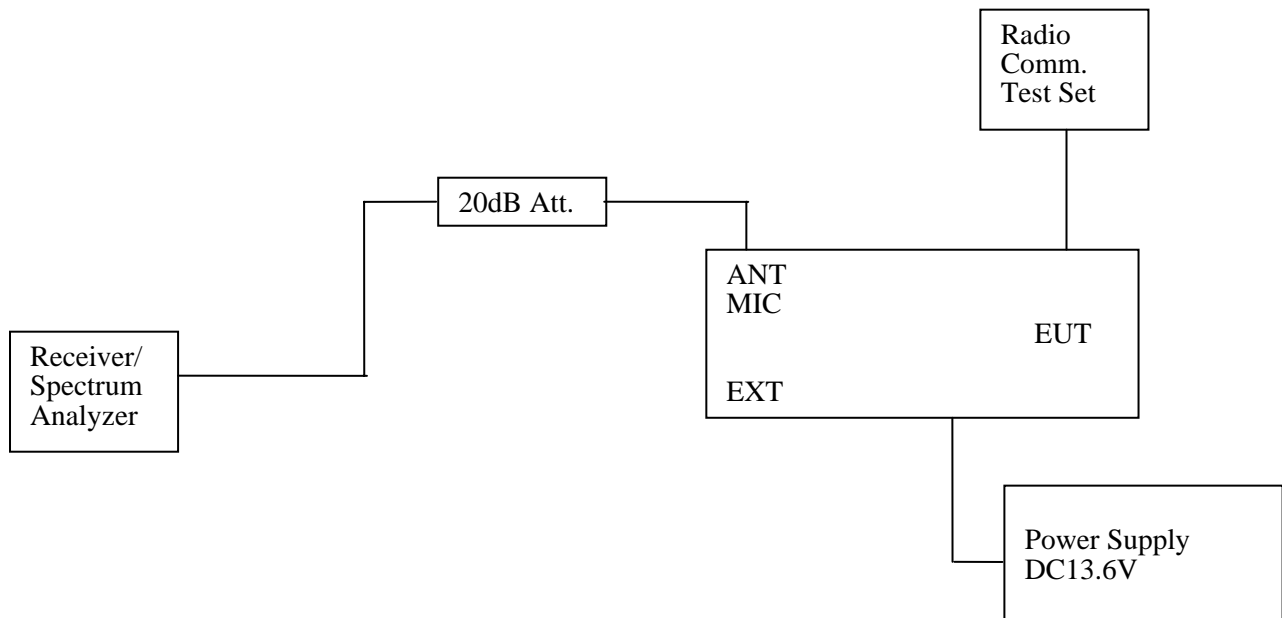

LIMIT

Modulation Type: FM

FCC Part 22.359, 74.462, 80.211 and 90.210 and RSS Gen, RSS 119 Issue 12:

For 12.5 kHz bandwidth:

On any frequency removed from the center of the authorized bandwidth by a displacement frequency (f_d in kHz) of more than 12.5 kHz at least:

High: $50 + 10 \log(P_{\text{watts}}) = 50 + 10 \log(45.0) = 66.53 \text{ dB}$

Low: $50 + 10 \log(P_{\text{watts}}) = 50 + 10 \log(5.0) = 56.99 \text{ dB}$

Note: In general, the worst case attenuation requirement shown above was applied.

Calculation: Limit (dBm) = EL - 50 - 10log₁₀(TP)

Notes: EL is the emission level of the Output Power expressed in dBm,

In this application, the EL is 46.53 dBm for Rated High power level and 37.02 dBm for Rated Lower power level;

High: Limit (dBm) = $46.53 - 50 - 10 \log_{10}(45.0) = -20$ dBm

Low: Limit (dBm) = $37.02 - 50 - 10 \log_{10}(5.0) = -20$ dBm

Modulation Type: 4FSK

FCC Part 22.359, 74.462, 80.211 and 90.210 and RSS Gen, RSS 119 Issue 12 (12.5 kHz Bandwidth only):

On any frequency removed from the center of the authorized bandwidth by a displacement frequency (f_d in kHz) of more than 12.5 kHz at least:

High: $50 + 10 \log(P_{\text{watts}}) = 50 + 10 \log(45.0) = 66.53$ dB

Low: $50 + 10 \log(P_{\text{watts}}) = 50 + 10 \log(5.0) = 56.99$ dB

Note: In general, the worst case attenuation requirement shown above was applied.

Calculation: Limit (dBm) = $EL - 50 - 10 \log_{10}(TP)$

Notes: EL is the emission level of the Output Power expressed in dBm,

In this application, the EL is 46.53 dBm for Rated High power level and 37.02 dBm for Rated Lower power level;

High: Limit (dBm) = $46.53 - 50 - 10 \log_{10}(45.0) = -20$ dBm

Low: Limit (dBm) = $37.02 - 50 - 10 \log_{10}(5.0) = -20$ dBm

Note:

1. In general, the worse case attenuation requirement shown above was applied.
2. The measurement frequency range from 9 KHz to 6GHz.

TEST RESULTS

Operation Mode	Test Channel	Test Frequency (MHz)	Maximum Conducted Spurious Emissions Below 1GHz		Maximum Conducted Spurious Emissions Above 1GHz	
			Frequency (MHz)	Data (dBm)	Frequency (MHz)	Data (dBm)
Op 1	Ch1	450.025	900.09	-25.86	1350.00	-30.70
	Ch2	467.775	935.98	-25.16	1405.00	-32.63
	Ch3	511.9875	713.85	-30.31	1535.00	-29.93
Op 5	Ch1	450.025	900.09	-26.28	1350.00	-31.05
	Ch2	467.775	935.98	-25.84	1405.00	-32.33
	Ch3	511.9875	676.02	-31.05	1535.00	-29.26
Limit			-20dBm for 12.5KHz Channel Separation			
Test Results			PASS			

Plots of Spurious Emission on Antenna Port Measurement

Operation Mode	Test Channel	Test Frequency (MHz)	Maximum Conducted Spurious Emissions Below 1GHz		Maximum Conducted Spurious Emissions Above 1GHz		Limit (dBm)
			Frequency (MHz)	Data (dBm)	Frequency (MHz)	Data (dBm)	
Op 1	Ch1	450.025	900.09	-25.86	1350.00	-30.70	-20.00

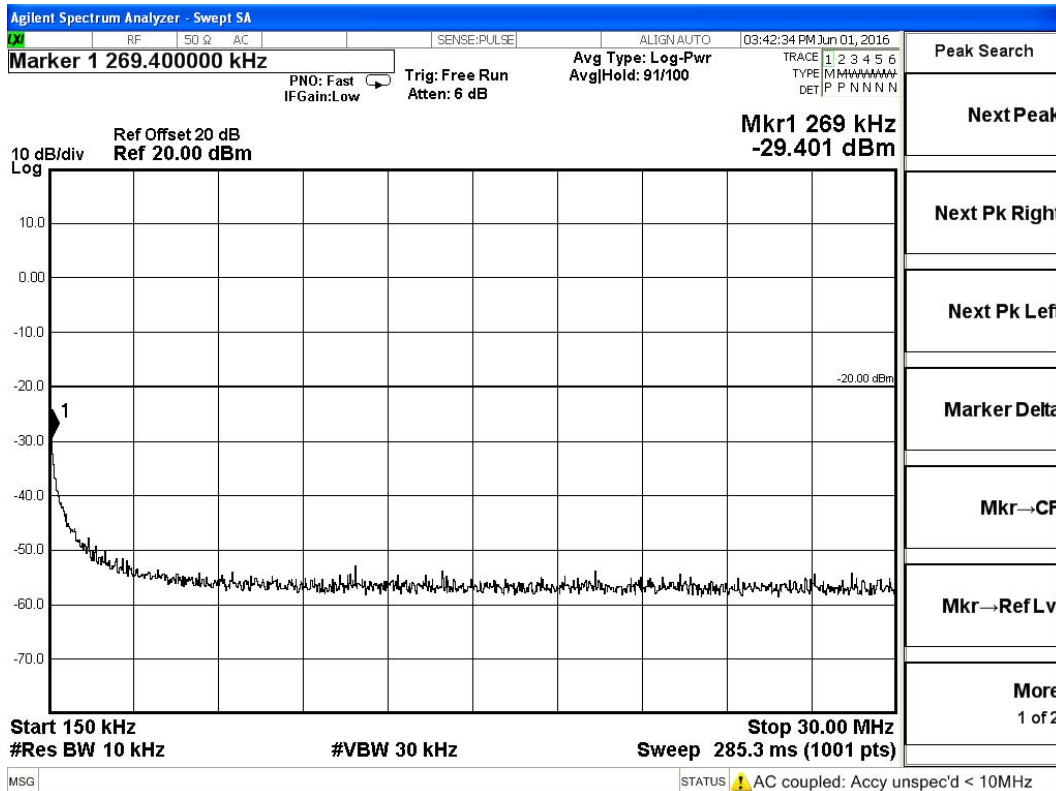
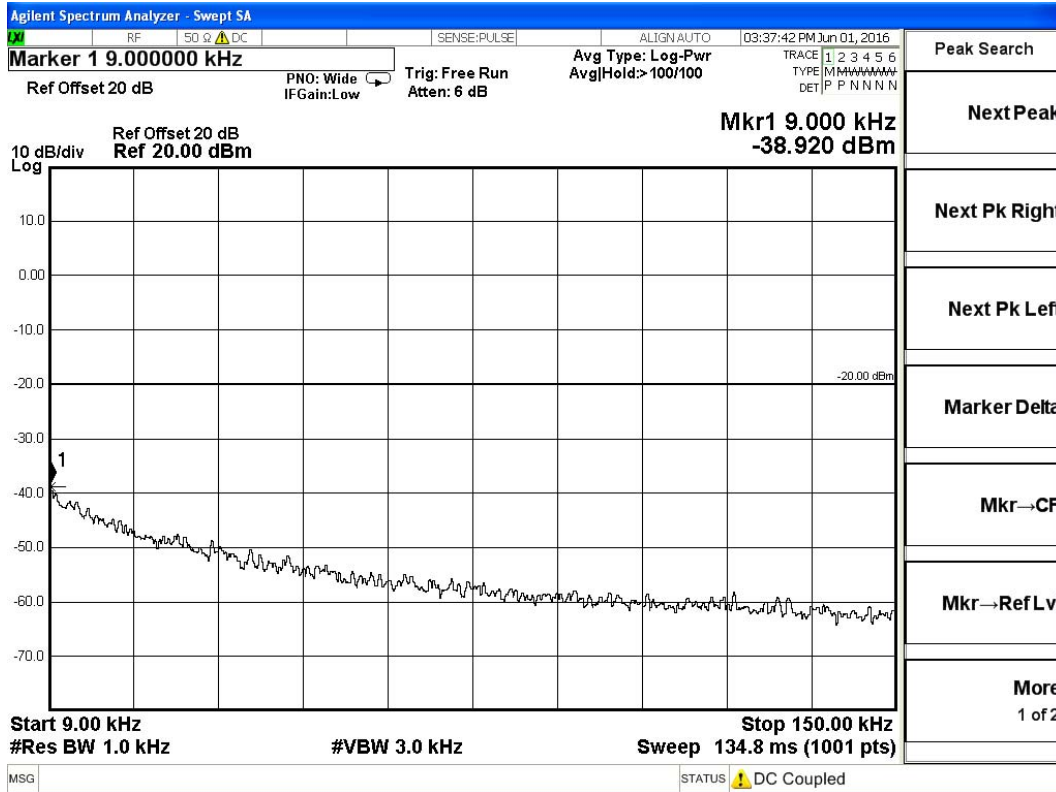

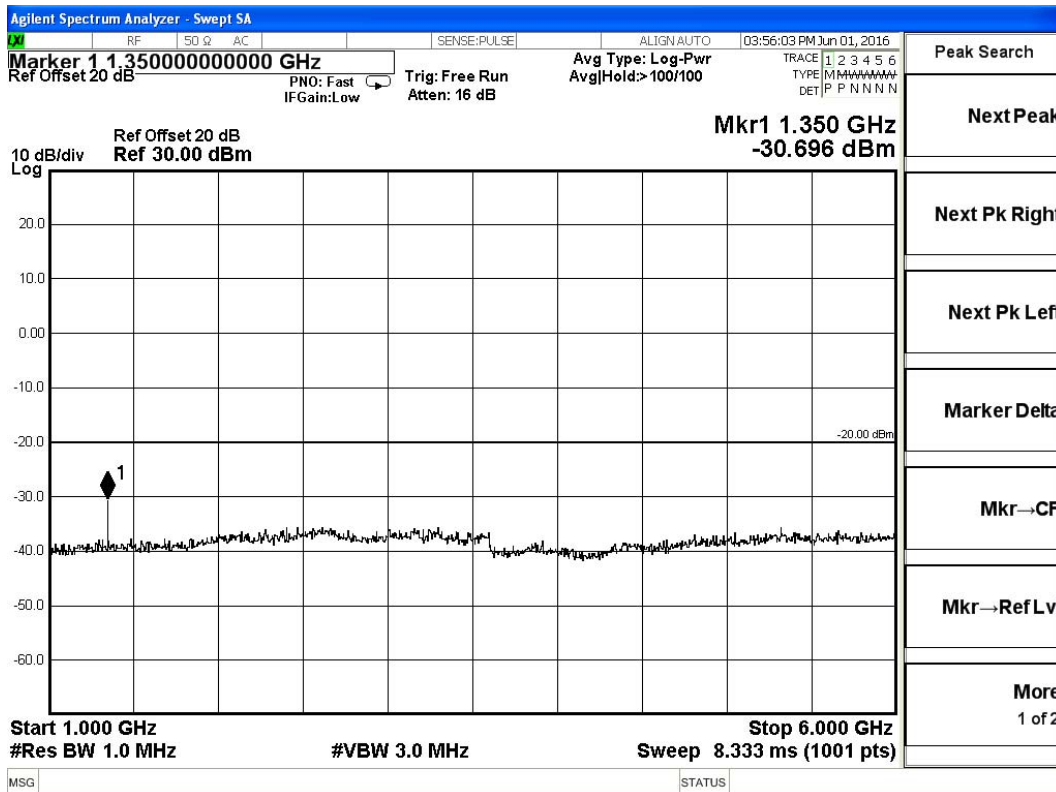
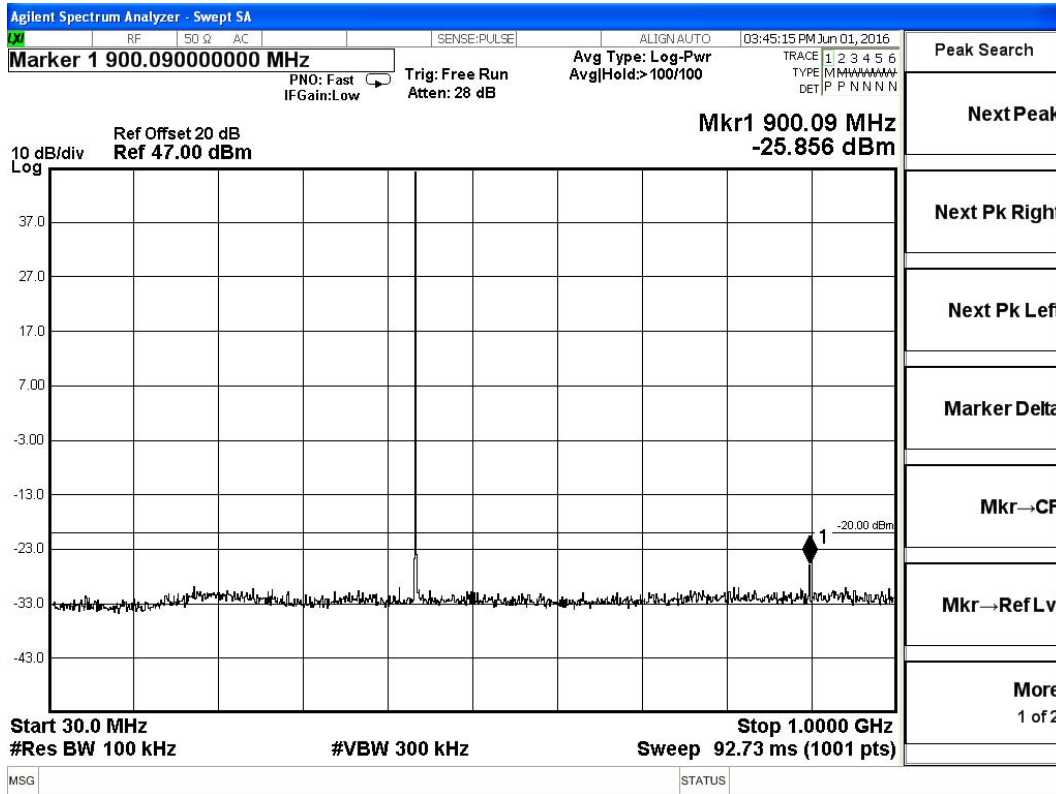

Operation Mode	Test Channel	Test Frequency (MHz)	Maximum Conducted Spurious Emissions Below 1GHz		Maximum Conducted Spurious Emissions Above 1GHz		Limit (dBm)
			Frequency (MHz)	Data (dBm)	Frequency (MHz)	Data (dBm)	
Op 1	Ch2	467.775	935.98	-25.16	1405.00	-32.63	-20.00

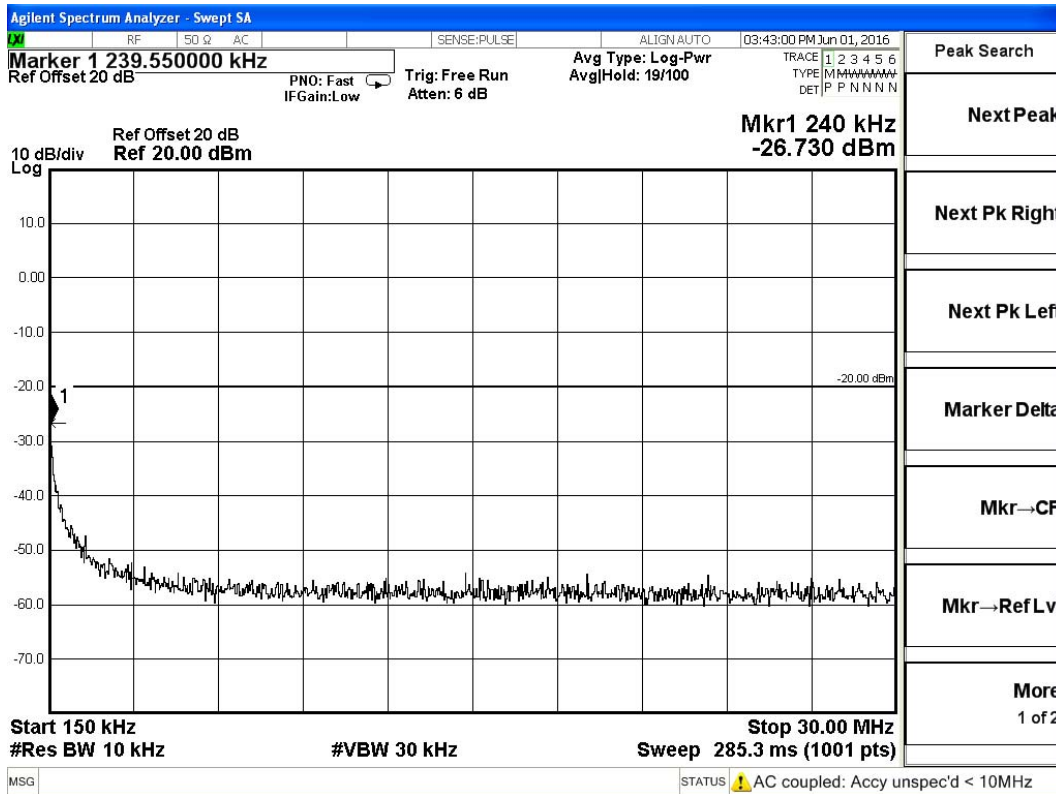
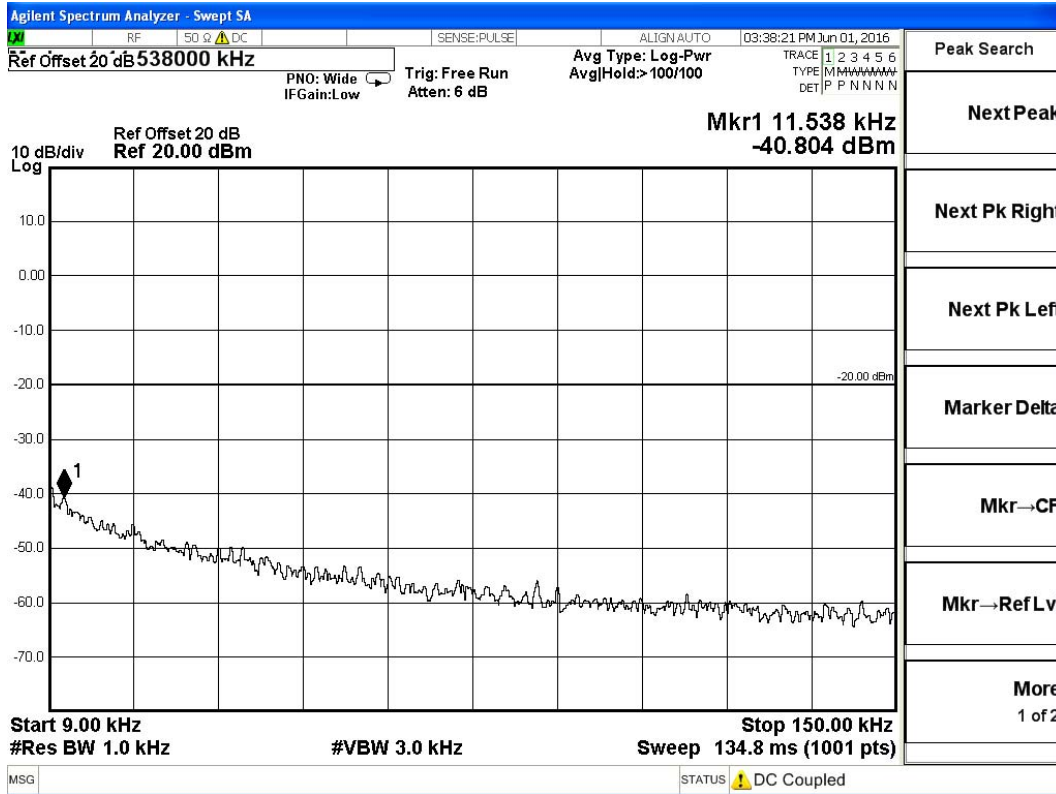

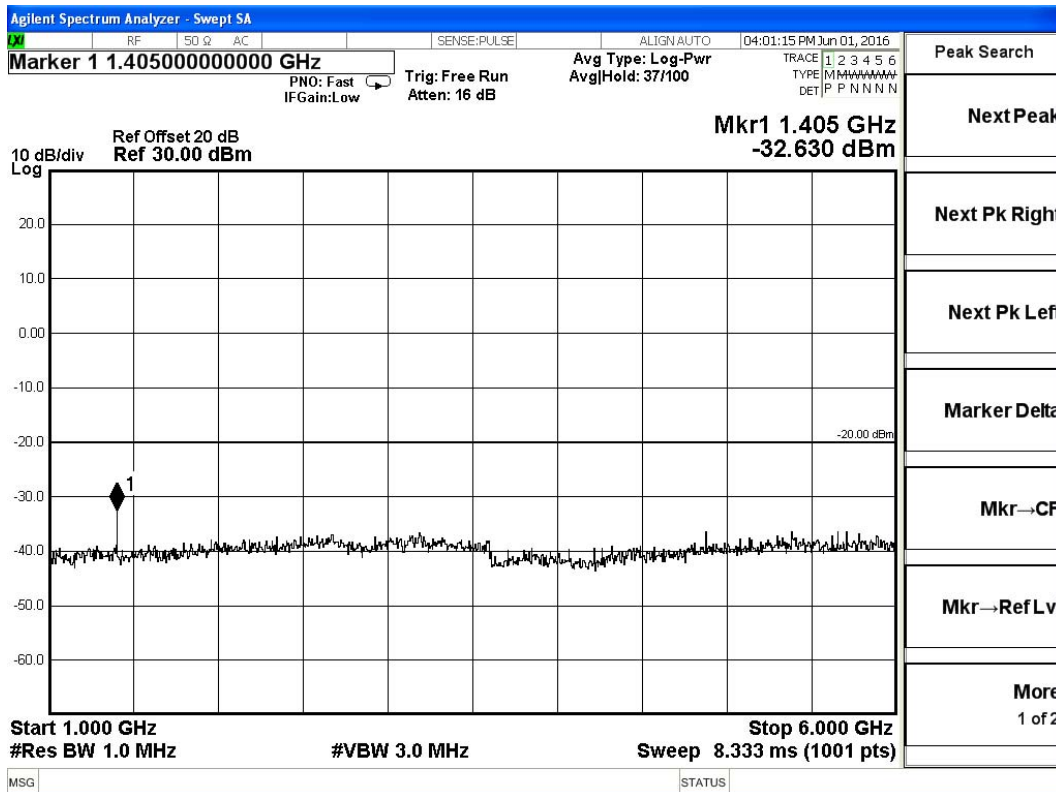
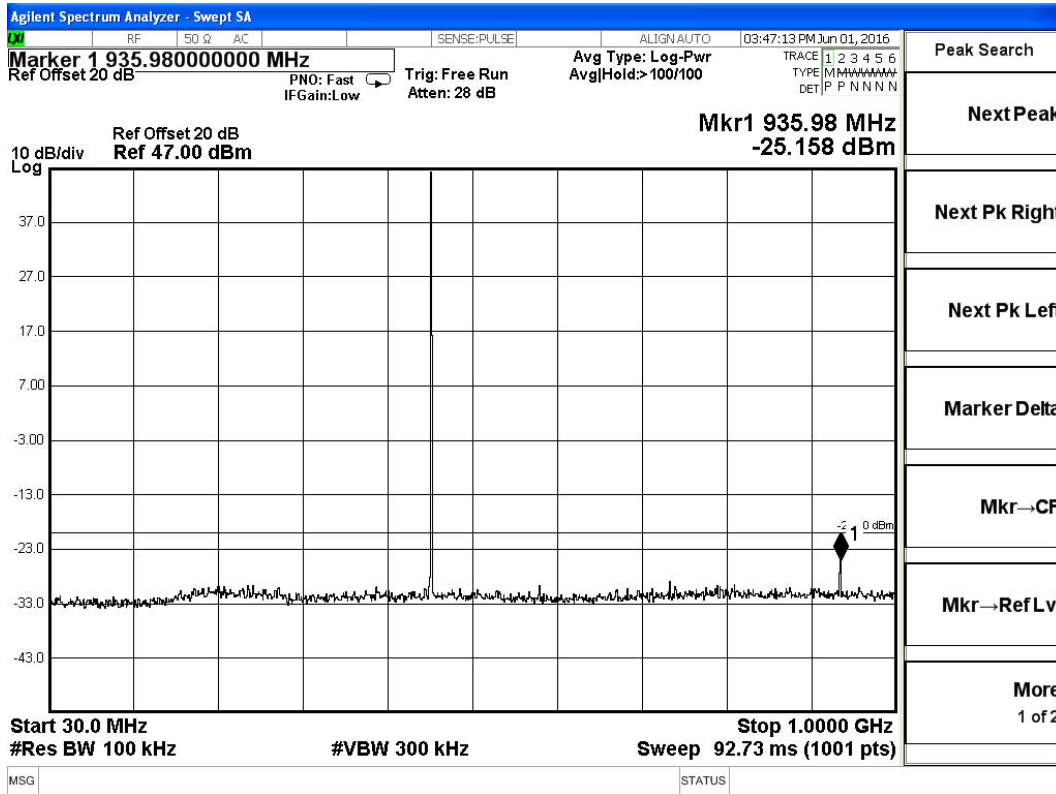

Operation Mode	Test Channel	Test Frequency (MHz)	Maximum Conducted Spurious Emissions Below 1GHz		Maximum Conducted Spurious Emissions Above 1GHz		Limit (dBm)
			Frequency (MHz)	Data (dBm)	Frequency (MHz)	Data (dBm)	
Op 1	Ch3	511.9875	713.85	-30.31	1535.00	-29.93	-20.00

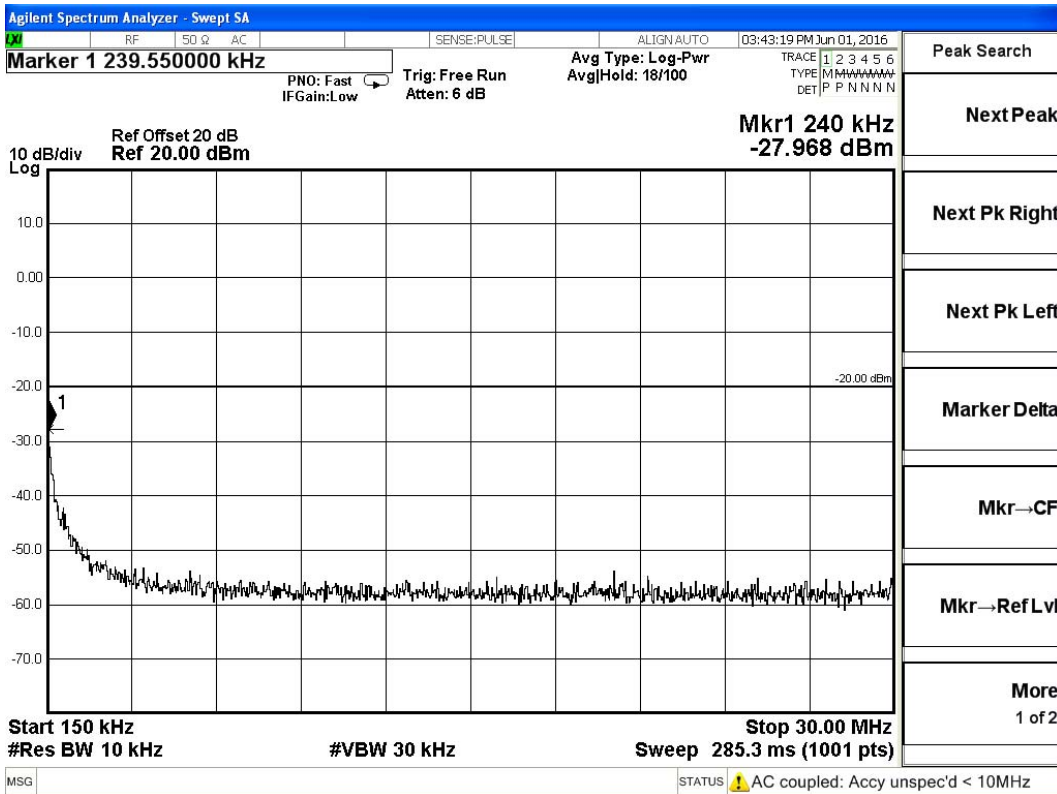
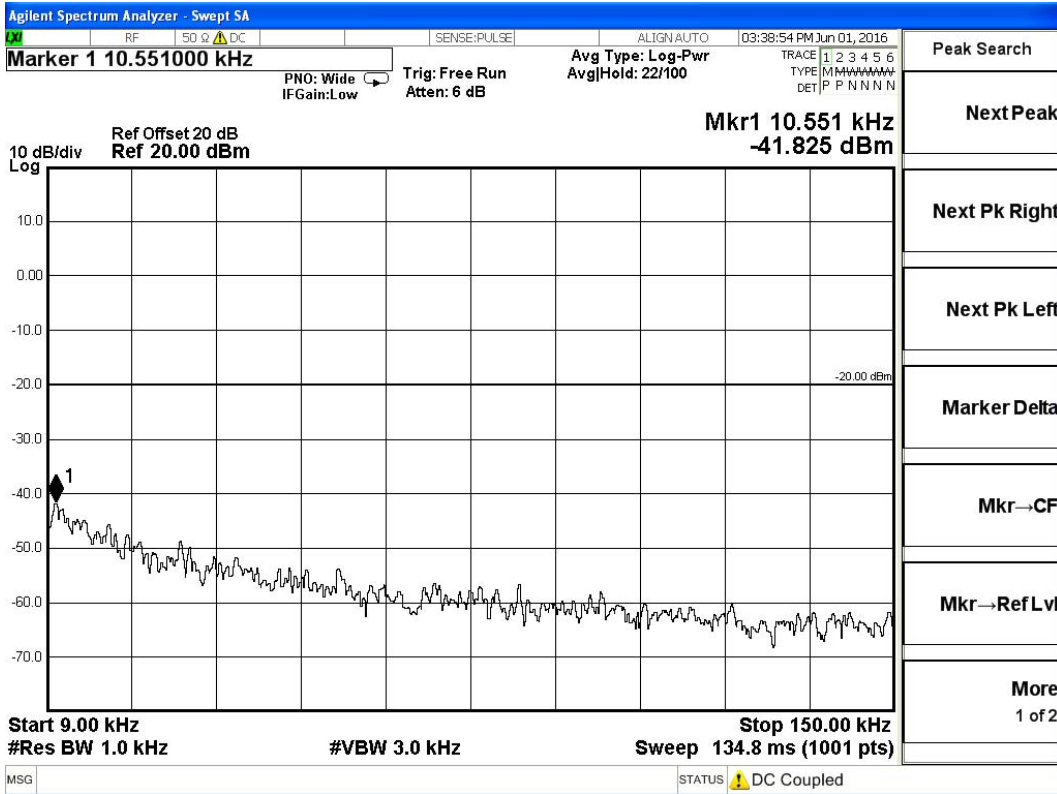

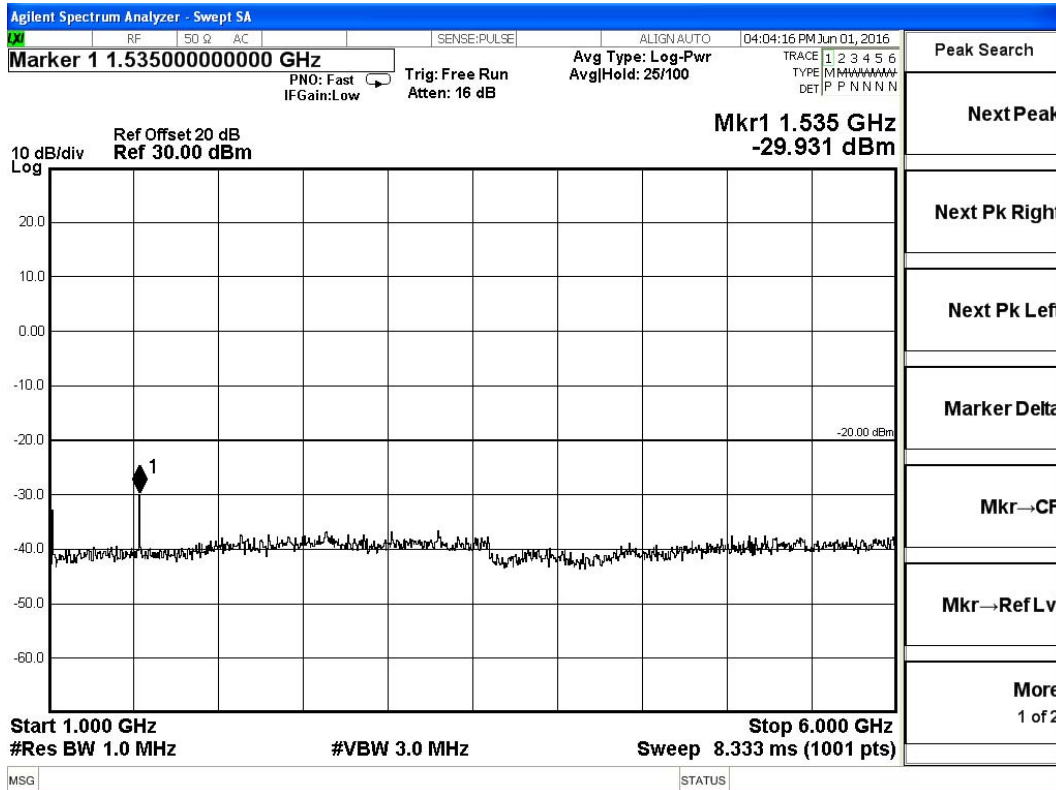
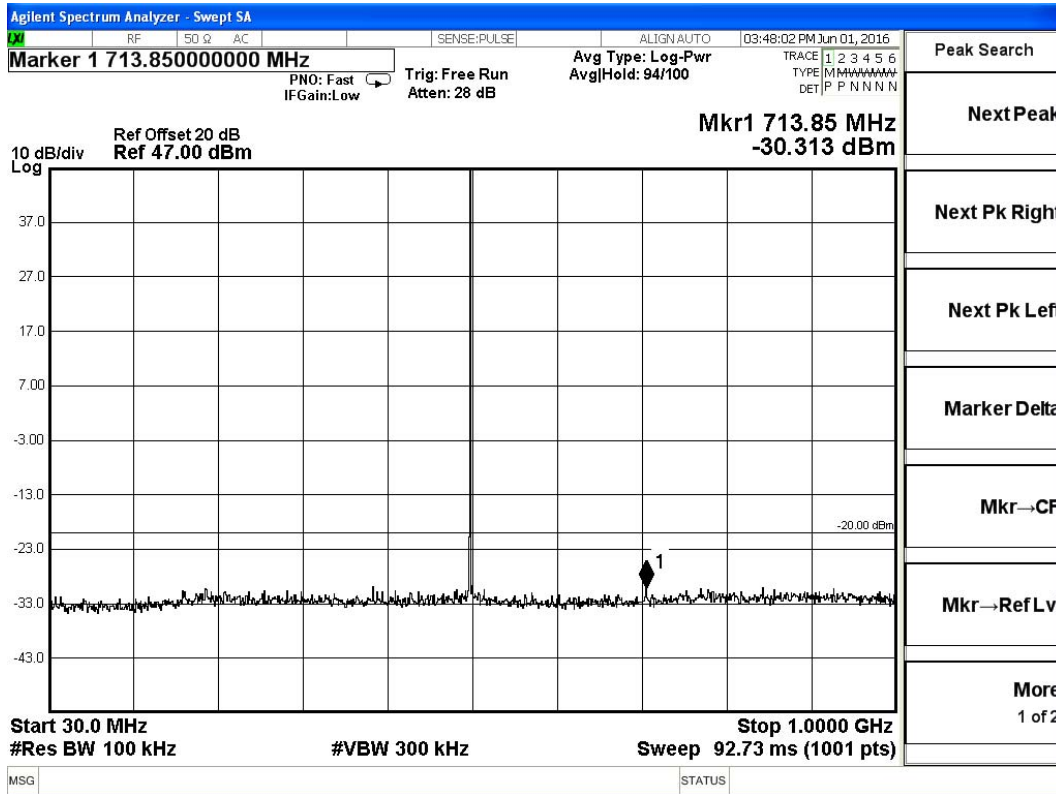

Operation Mode	Test Channel	Test Frequency (MHz)	Maximum Conducted Spurious Emissions Below 1GHz		Maximum Conducted Spurious Emissions Above 1GHz		Limit (dBm)
			Frequency (MHz)	Data (dBm)	Frequency (MHz)	Data (dBm)	
Op 3	Ch7	450.025	900.09	-25.84	1350.00	-31.05	-20.00

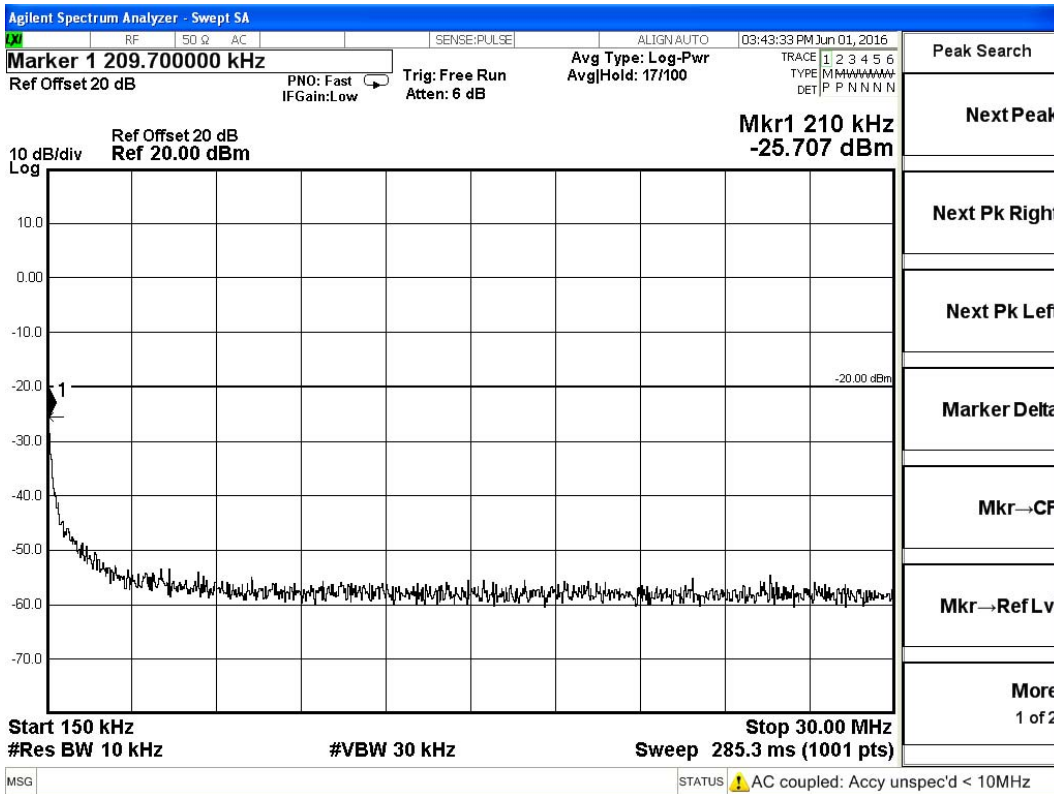
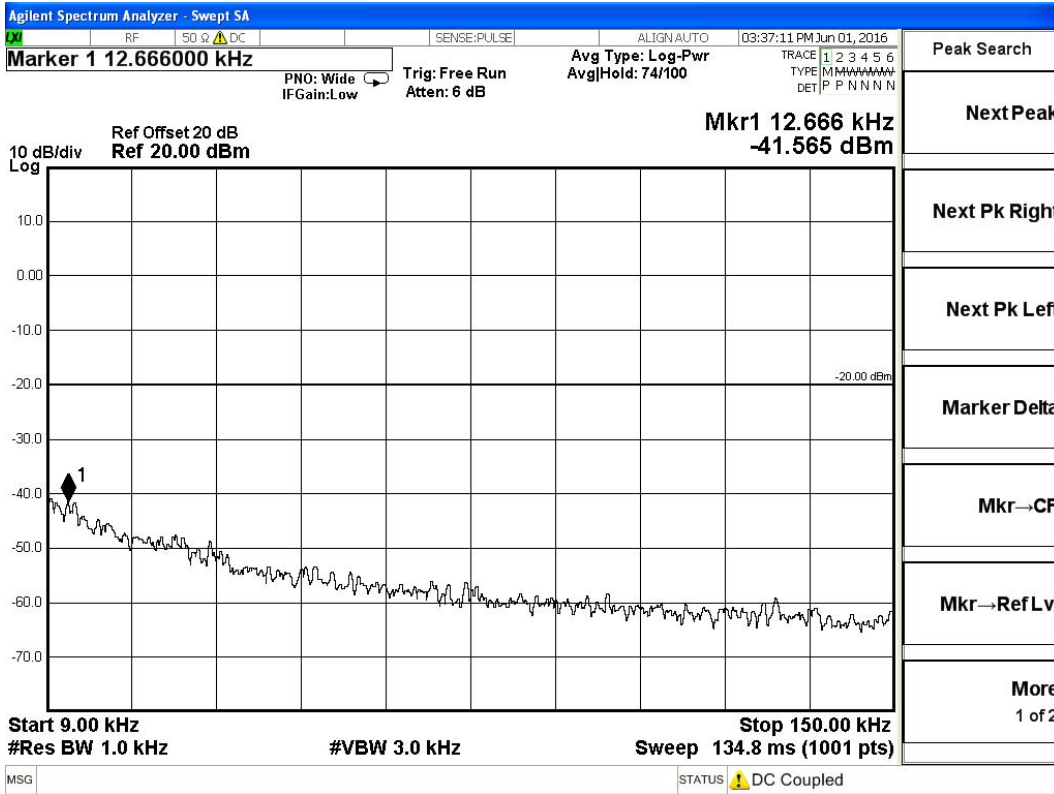

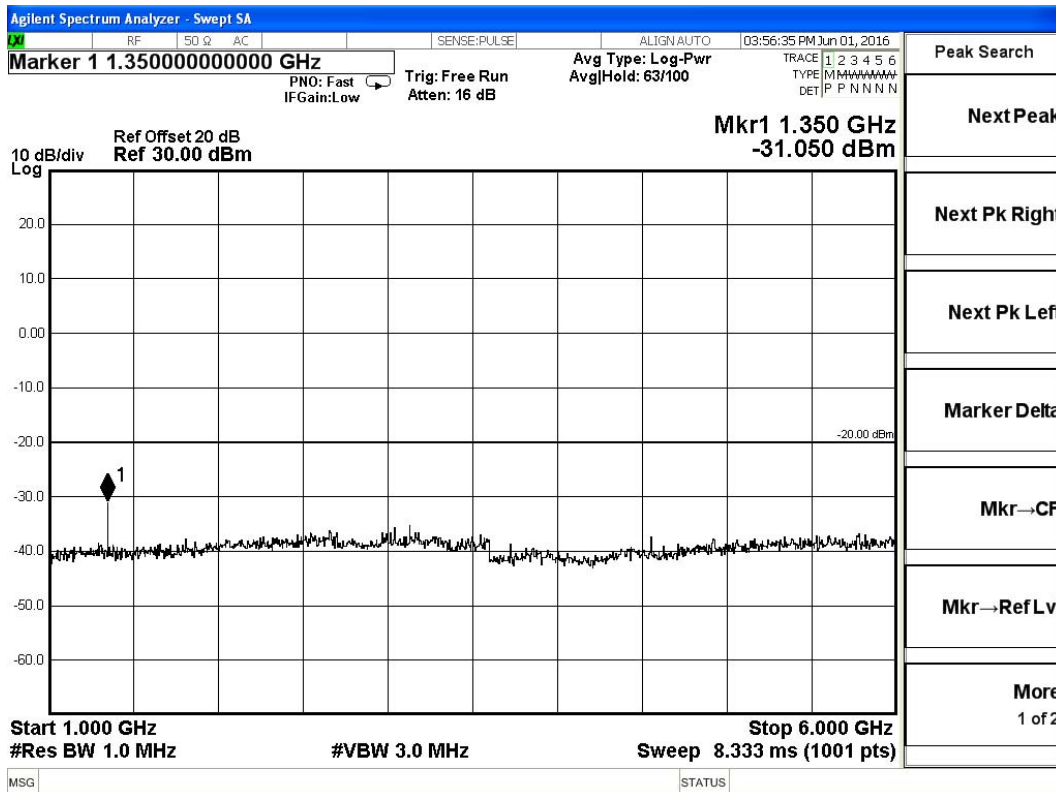
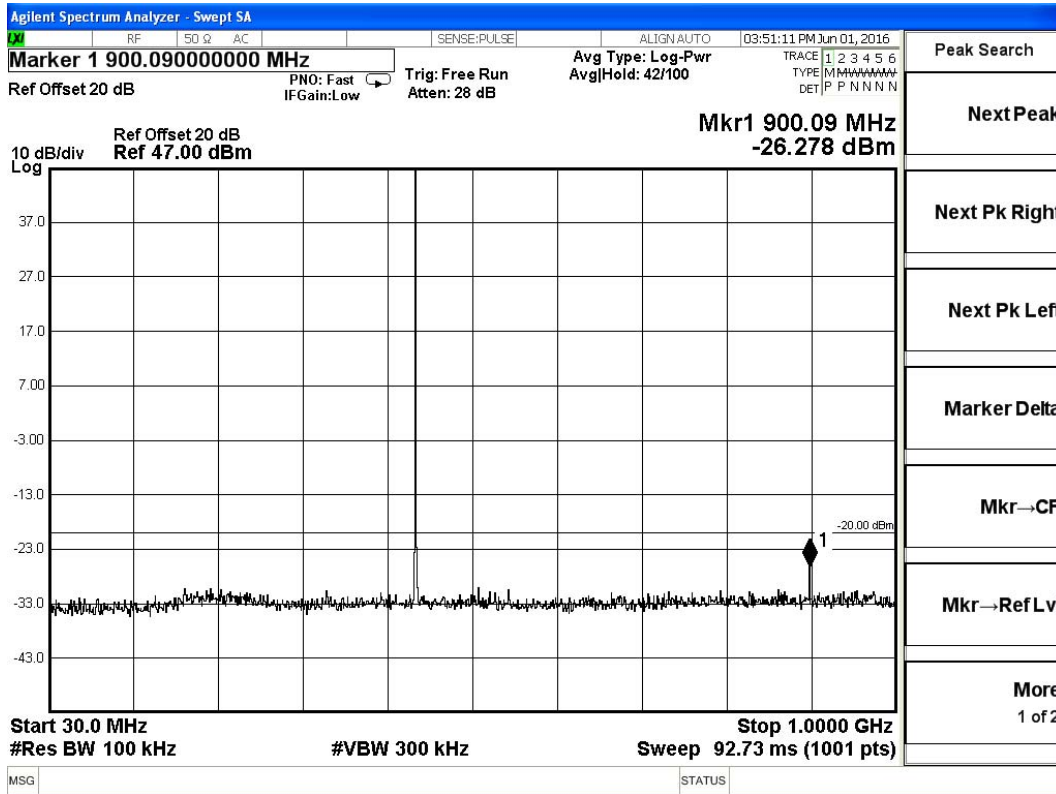

Operation Mode	Test Channel	Test Frequency (MHz)	Maximum Conducted Spurious Emissions Below 1GHz		Maximum Conducted Spurious Emissions Above 1GHz		Limit (dBm)
			Frequency (MHz)	Data (dBm)	Frequency (MHz)	Data (dBm)	
Op 3	Ch8	467.775	935.98	-25.84	1405.00	-32.33	-20.00

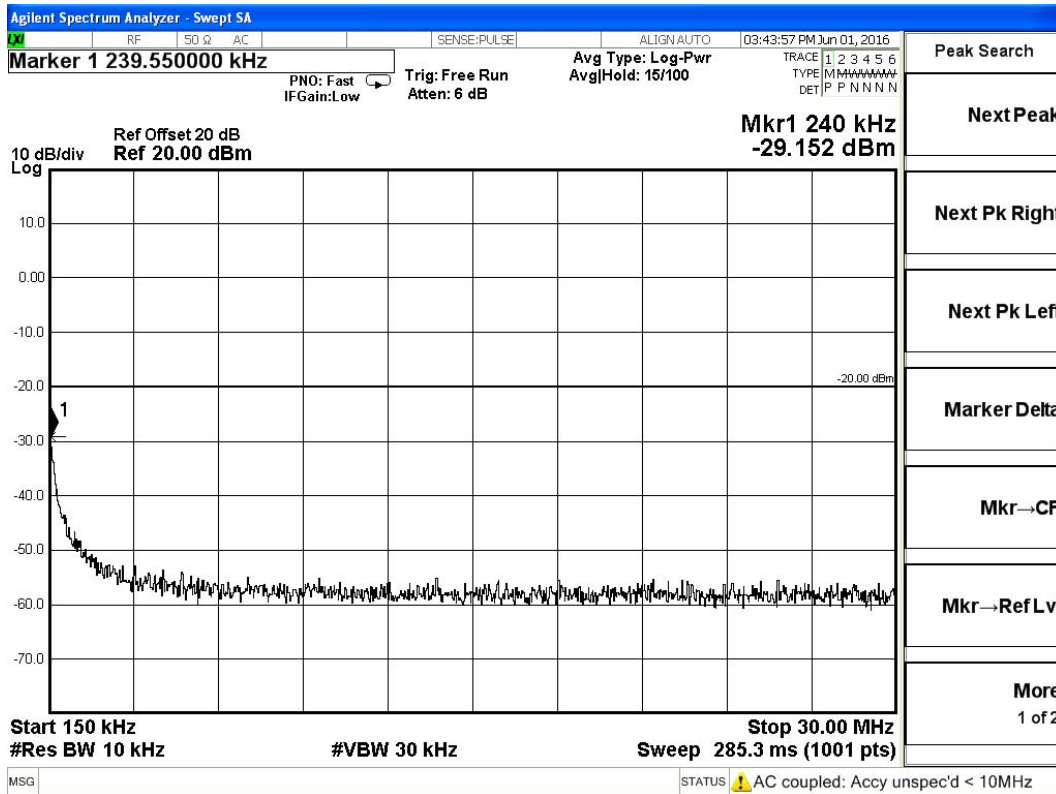
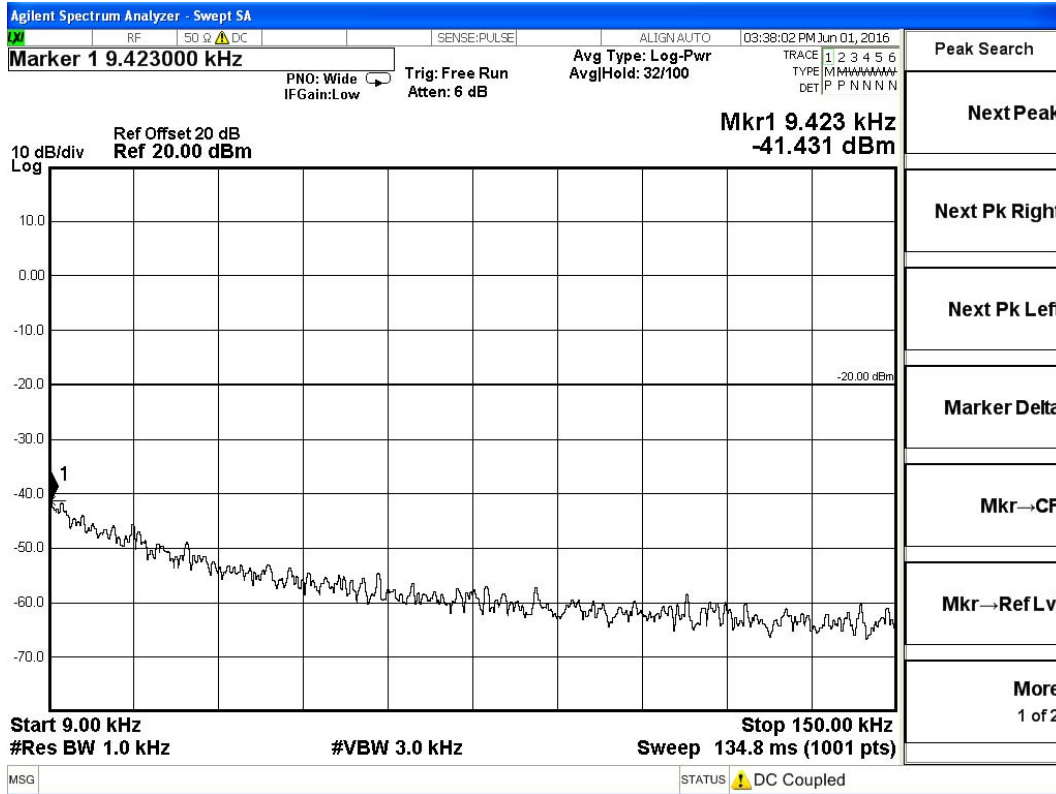

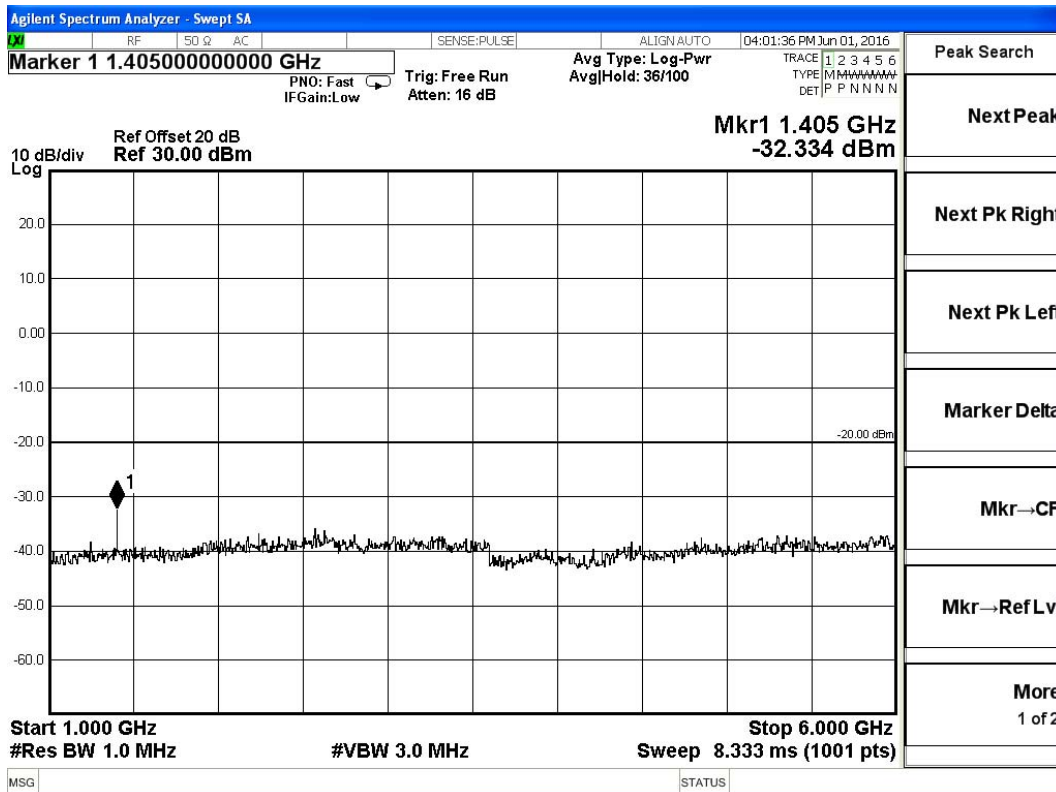
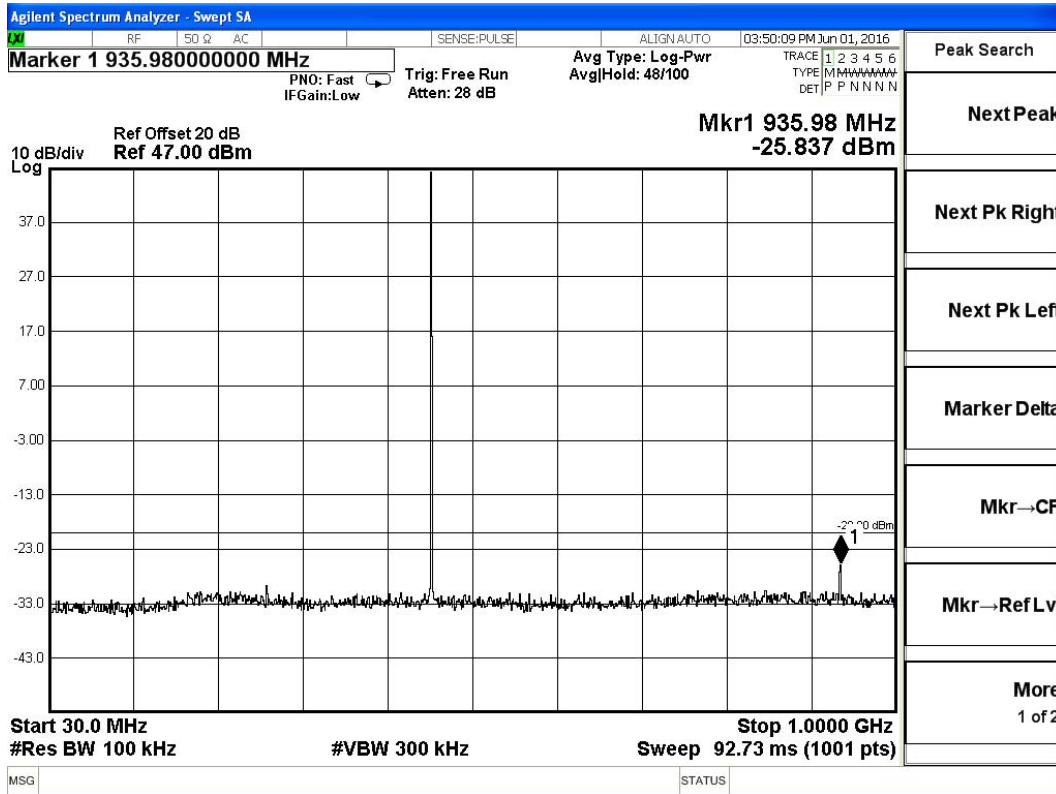

Operation Mode	Test Channel	Test Frequency (MHz)	Maximum Conducted Spurious Emissions Below 1GHz		Maximum Conducted Spurious Emissions Above 1GHz		Limit (dBm)
			Frequency (MHz)	Data (dBm)	Frequency (MHz)	Data (dBm)	
Op 3	Ch9	511.9875	676.02	-31.05	1535.00	-29.26	-20.00

