

**SPM6000 SERIES
OWNER'S MANUAL**

Digital Two Way Radio

www.samhoo-pmr.com

The logo for Samhoo, featuring the word "Samhoo" in a white, italicized, sans-serif font. The letters are closely spaced, and the 'S' is particularly large and stylized. The logo is centered within a dark gray horizontal band.

Dear customers:



Thank you very much for your favor in our products! In order to get optimal performance from the product, please read this manual carefully before using it.

This manual applies to the following models:

SPM6015, SPM6035, SPM6040, SPM6050 mobile terminals etc.

Icon Illustration

The following icons are available through this manual:

-  Attention: Indicates situations that could cause damage to your radio.
-  Note: Indicates tips that can help you make better understanding and use of your radio.
- * Asterisk: Indicates the currently restricted function.

Term Explanation

Key operation

Short press: To press the key and release it quickly;

Long press: To press the key and remain holding it down more than a period of 1.5 seconds.

Hold down: To press the key and remain holding it down.

Individual Call

Individual call is a call initiated by one user to another user.

Group Call

Group call is a call initiated by a user to all users in a group.

Emergency Call

Emergency call is the highest priority call. And you can ask companions

or emergency control center for help when you are in emergency. It's can interrupt non-emergency calls if starting the emergency call.

Conventional Mode

In conventional mode, between the terminals, they can proceed to use simplex communication, which is not limited to the network, but users can't use the functions that need the network.

Trunking Mode

In trunking mode, the terminals communicate via the base station, and users can use the functions that need the base station supporting. If you need to operate in the trunking mode, at first, you must register to the base station to obtain the permission of the service provider, and the terminals should be kept under network coverage.

Copyright Information

Shenzhen Samhoo Sci & Tech Co., Ltd. (hereinafter referred to as "Samhoo") is a trademark or a registered trademark of the People's Republic of China and or / other countries or areas. Samhoo retains the ownership of its trademarks and product names. All other trademarks and / or product names that may be used in this manual are properties of their respective owners. The Samhoo product described in this manual may include Samhoo computer programs stored in memory or other media. Laws in PRC and / or other countries or areas protect the exclusive rights of Samhoo with respect to its computer programs. The purchase of this product shall not be deemed to grant, either directly or by implication, any rights to the purchaser with respect to Samhoo computer programs. Any Samhoo computer programs may not be copied, modified, distributed, decompiled, or reverse-engineered in any manner without the prior written consent of Samhoo.

Disclaimer

Samhoo endeavors to achieve the accuracy and completeness of this manual, but with regard to all the possible mistakes and omissions, Samhoo does not undertake any responsibility. All the specifications and designs are subject to change without notice due to continuous technological development. No part of this manual may be copied, modified, translated, or distributed in any manner without the authorized written permission of Samhoo.

If you have any suggestions or would like to learn more details, please visit our web site:

<http://www.samhoo-pmr.com> or dial service hotline: 0086-755 8316 0260.

RF Energy Exposure Awareness and Control Information and Operational Instructions for Occupational Use

Notice: this radio is intended for use in occupational/controlled conditions where users have full knowledge of their exposure and can exercise control over their exposure to meet the occupational limits in FCC and International standards. This radio device is NOT authorized for general population consumer use.

Federal Communication Commission (FCC) Regulations

When Digital Two Way Radio is used as a consequence of employment, the FCC requires users to be fully aware of and able to control their exposure to meet occupational requirement. Exposure awareness can be facilitated by the use of a product label directing users to specific user awareness information. Your Digital Two-Way Radio has a RF Exposure Product Label. Also, your Digital Two Way Radio user manual includes information and operating instructions required to control your RF exposure and satisfy compliance requirements.

Compliance with RF Exposure Standards

Your Digital Two Way Radio is designed and tested to compliance with a number of national and international standards and guidelines for human exposure to radio frequency electromagnetic energy. This radio compliance with the IEEE (FCC) and ICNIRP exposure limits for occupational/controlled RF exposure environments at operating duty factors of up to 50% talk 50% listen and is approved for occupational use only. In terms of measuring RF energy for compliance with these exposure guidelines, your radio generates measurable RF energy only while it is transmitting (during talking), not when it is receiving (listening) or in standby mode.

Your Digital Two Way Radio complies with the following RF energy exposure standards and guidelines:

- United States Federal Communications Commission (FCC), Code of Federal Regulations;
- Institute of Electrical and Electronic Engineers (IEEE) C95.1;
- International Commission on Non-ionizing Radiation Protection (ICNIRP);

RF Exposure Compliance and Control Guidelines and Operating Instructions for Two Way Radio Operations

To control your exposure and ensure compliance with the occupational/controlled environment exposure limits, always adhere to the following procedures;

- DO NOT remove the RF Exposure Label from the device
- User awareness instructions should accompany device when transferred to other users.

Operational Instructions and Training Guidelines

To ensure optimal performance and compliance with the occupational/controlled environment RF energy exposure limits in the above standards and guidelines, users should transmit no more than 50% of the time and always adhere to the following procedures;

- Antenna gain must not exceed 3.65 dBi for UHF and VHF.
- The antenna installation must comply with the requirements of manufacturer or supplier, and it must be 1.08 meter away from human body.

Note: RF exposure decrease with increasing distance from the antenna.

- To ensure optimal performance and compliance with the occupational/controlled environment RF energy exposure limits in the above standards and guidelines, users should transmit no more than 50% of the time and always adhere to the following procedures; and should transmit no more than 50% of the time, although the hardware support transmission up to 100% of the time in analog mode and up to 50% in digital mode.

FCC Statement

This equipment has been tested and found to comply with the limits for a Class B digital device, pursuant to part 15 of FCC Rules. These limits are designed to provide reasonable protection against harmful interference in a residential installation. This equipment generates and can radiate radio frequency energy and, if not installed and used in accordance with the instructions, may cause harmful interference to radio communications. However, there is no guarantee that interference will not occur in a particular installation. If this equipment does cause harmful interference to radio or television reception, which can be determined by turning the equipment off and on, the user is encouraged to try to correct

The interference by one or more of the following measures:

Reorient or relocate the receiving antenna.

Increase the separation between the equipment and receiver.

Connect the equipment into an outlet on a circuit different from that to which the receiver is connected.

Consult the dealer or an experienced radio/TV technician for help.

This device complies with Part 15 of FCC Rules.

Operation is subject to the following two conditions:

This device may not cause harmful interference, and this device must accept any interference received, including interference that may cause undesired operation.

Note: The manufacturer is not responsible for any radio or TV interference caused by unauthorized modifications to this equipment. Such modifications could void the user's authority to operate this equipment.

NOTICES TO THE USER

- ◆ Government law prohibits the operation of unlicensed transmitters within the territories under government control.
- ◆ Illegal operation is punishable by fine and/or imprisonment.
- ◆ Refer service to qualified technicians only.

SAFETY: It is important that the operator is aware of, and understands, hazards common to the operation of any transceiver.



◆ **EXPLOSIVE ATMOSPHERES (GASES, DUST, FUMES, etc.)**

Turn OFF your transceiver while taking on fuel or while parked in gasoline service stations. Do not carry spare fuel containers in the trunk of your vehicle if your transceiver is mounted in the trunk area.

◆ **INJURY FROM RADIO FREQUENCY TRANSMISSIONS**

Do not operate your transceiver when somebody is either standing near to or touching the antenna, to avoid the possibility of radio frequency burns or related physical injury.

◆ **DYNAMITE BLASTING CAPS**

Operating the transceiver within 500 feet (150 m) of dynamite blasting caps may cause them to explode. Turn OFF your transceiver when in an area where blasting is in progress, or where "TURN OFF TWO-WAY RADIO" signs have been posted. If you are transporting blasting caps in your vehicle, make sure they are carried in a closed metal box with a padded interior. Do not transmit while the caps are being placed into or removed from the container.

One or more of the following statements may be applicable:

FCC WARNING

This equipment generates or uses radio frequency energy. Changes or modifications to this equipment may cause harmful interference unless the modifications are expressly approved in the instruction manual. The user could lose the authority to operate this equipment if an unauthorized change or modification is made.

INFORMATION TO THE DIGITAL DEVICE USER REQUIRED BY THE FCC

This equipment has been tested and found to comply with the limits for a Class B digital device, pursuant to Part 15 of the FCC Rules. These limits are designed to provide reasonable protection against harmful interference in a residential installation. This equipment generates uses and can generate radio frequency energy and, if not installed and used in accordance with the instructions, may cause harmful interference to radio communications. However, there is no guarantee that the interference will not occur in a particular installation. If this equipment does cause harmful interference to radio or television reception, which can be determined by turning the equipment off and on, the user is encouraged to try to correct the interference by one or more of the following measures:

- Reorient or relocate the receiving antenna.
- Increase the separation between the equipment and receiver.
- Connect the equipment to an outlet on a circuit different from that to which the receiver is connected.
- Consult the dealer for technical assistance.

PRECAUTIONS

Observe the following precautions to prevent fire, personal injury, and transceiver damage.

- Do not attempt to configure the transceiver while driving; it is too dangerous.
- Do not disassemble or modify the transceiver for any reason.
- Do not expose the transceiver to long periods of direct sunlight, nor place it near heating appliances.
- If an abnormal odor or smoke is detected coming from the transceiver, switch the transceiver power off immediately, and contact your **SAMHOO** dealer.
- Use of the transceiver while you are driving may be against traffic laws. Please check and observe the vehicle regulations in your area.
- Do not use options not specified by **SAMHOO**

- ◆ The transceiver operates in 12 V negative ground systems only! Check the battery polarity and voltage of the vehicle before installing the transceiver.
- ◆ Use only the supplied DC power cable or a **SAMHOO** optional DC power cable.
- ◆ Do not cut and/or remove the fuse holder on the DC power cable.



For passenger safety, install the transceiver securely using the supplied mounting bracket and screw set so the transceiver will not break loose in the event of a collision.

Antenna substitution: Do not substitute any antenna for the one supplied or recommended by the manufacturer or radio dealer.

You may be exposing person or persons to excess radio frequency radiation.

You may contact your radio dealer or the manufacturer for further instructions.

Maintain a separation distance from the antenna to person(s) of at least, 50% duty Cycle.

This transmitter is authorized to operate with a maximum duty factor of 50%, in typical push-to-talk mode, for satisfying FCC RF exposure compliance requirements.





To comply with RF exposure requirements, a minimum separation distance of 80cm and with a 2dB cable loss is required between antenna and all public persons.

Content

| | | | |
|---|----|--|----|
| Packing List..... | 2 | Emergency Call..... | 10 |
| Optional Accessories..... | 3 | Menu Navigation..... | 11 |
| Product Overview..... | 4 | [Functions]..... | 11 |
| Installation..... | 5 | Phonebook..... | 11 |
| Precautions..... | 5 | Messages..... | 12 |
| Installation Tools..... | 5 | Call Log..... | 14 |
| Installation Steps..... | 5 | Profiles..... | 14 |
| Installation Diagram..... | 6 | Settings..... | 15 |
| Status Indication..... | 7 | Location..... | 15 |
| LCD Icon..... | 7 | [Options]..... | 16 |
| LED Indicator..... | 7 | Radio Mode..... | 16 |
| Basic Operations..... | 8 | Channel Management..... | 16 |
| Turning the Radio On / Off..... | 8 | Scan*..... | 16 |
| Knob Switch Mode..... | 8 | Information..... | 16 |
| Radio Mode..... | 8 | Troubleshooting..... | 17 |
| Adjusting the Volume..... | 8 | Care and Cleaning..... | 19 |
| Adjusting the Power Level..... | 8 | Quality Assurance and Maintenance Terms..... | 19 |
| Lock and unlock..... | 8 | | |
| Switching Channel / Group..... | 8 | | |
| Call..... | 10 | | |
| Individual Call..... | 10 | | |
| Group Call..... | 10 | | |
| Telephone Call (Only in trunking mode)..... | 10 | | |

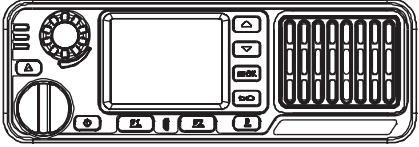
Pcking List

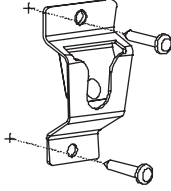
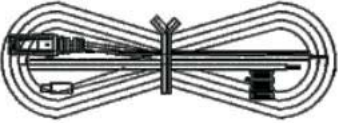
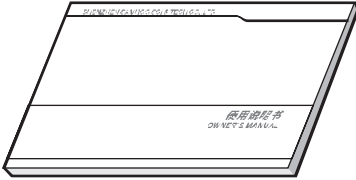



The package includes the following items. If any item is missing or damaged, please contact your dealer.

| | | |
|---|---|---|
|  |  |  |
| Radio Unit | Handheld Microphone | Microphone Hanger and Screws |
|  |  |  |
| DC Power Cable | Owner's Manual | Quick Reference User Guide |

 Note: Standard config for mobile terminal with trunking function is digital keyboard and handheld microphone, while for conventional function is normal handheld microphone.

Optional Accessories

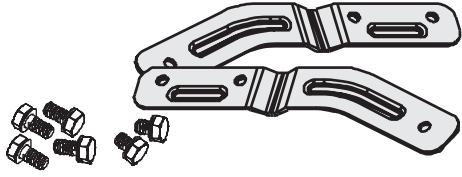
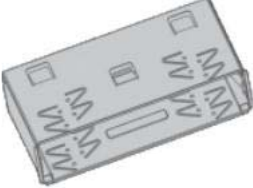
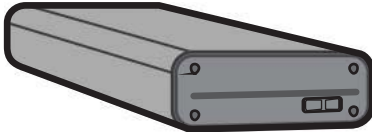
The following items are the main optional accessories of the product, if you need more information about the accessories, please consult your local dealer.

| | | |
|---|---|---|
|  |  |  |
| <p>Handheld Microphone with Numeric Keypad</p> | <p>U-shaped Bracket</p> | <p>Bracket</p> |
|  |  |  |
| <p>Mobile Terminal Support Kit</p> | <p>Reserve Power Supply</p> | <p>Data Cable</p> |
|  | | |
| <p>Omni's Directional Antenna</p> | | |

 Note: For more details about the accessories, please contact our company.

Product Overview

Introduction of Parts

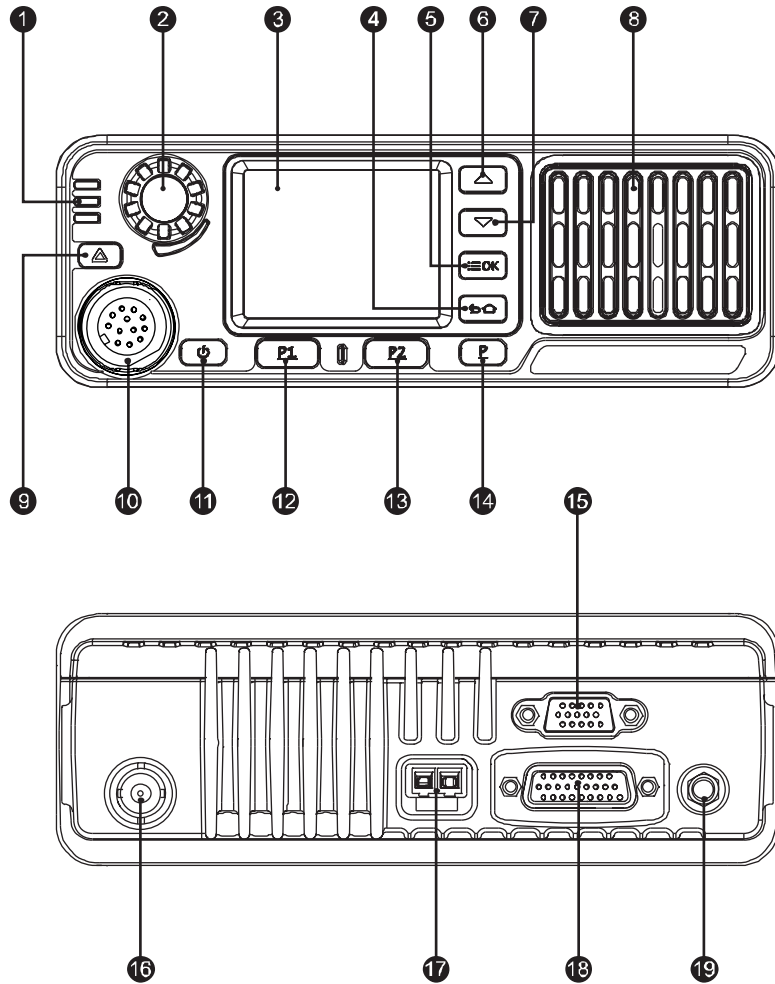

| No. | Part Name | No. | Part Name |
|-----|--------------------------------------|-----|--|
| 1 | LED Indicator | 2 | Volume Control / Channel Selector Knob |
| 3 | LCD Display | 4 | Option / Back / Home Button |
| 5 | Menu / Enter Button | 6 | Up Button |
| 7 | Down Button | 8 | Speaker |
| 9 | Emergency Call Button | 10 | Handheld microphone interface |
| 11 | Power On / Off / On-hook button | 12 | Enter / P1 Key |
| 13 | Cancel / P2 Button | 14 | Power Level / Lock / Unlock button |
| 15 | Accessories Interface | 16 | RF Antenna Base |
| 17 | Power Interface | 18 | Accessories Interface |
| 19 | Positioning Module Antenna Interface | | |

Installation

Precautions

Before installing the mobile terminal, please read the following precautions carefully:

- The radio operates with cathode-grounded power supply of $13.6V \pm 15\%$ only. Please check polarity and voltage of the power supply on the vehicle before you install the radio.
- Please check how long the screws will extend from the bottom surface of the radio, before you install the radio. Drill the mounting hole cautiously to avoid damage to the vehicle wiring and other parts.
- Please connect Samhoo supplied antenna and power cord to the radio, before you install it in the bracket. And make sure the antenna and power cord is dedicated for Samhoo digital radios to prevent injuries to passengers.
- Set the mobile terminal in a location convenient on the front panel for easy operation.
- Please make sure there's sufficient space at back of the radio for wiring.
- When the fuse for DC power cord needs replacement, it must be replaced by a fuse with the same specification.

Installation Tools

- Electric Drill
- Cross Head Screwdriver
- Hex Socket Sleeve

Installation Steps

Install the radio as instructed below:

1. Install the bracket in a location where it's easy to operate the radio.
2. Connect accessories such as antenna and power cord to the radio.
3. Slide the radio into the mounting bracket and fix by using the locking knobs.
4. Install the microphone hanger in a convenience location.
5. Plug the handheld microphone into the microphone jack on the front panel. Place the handheld microphone on the hanger when you do not use it.

Installation Diagram

The installation of this product is shown as below:

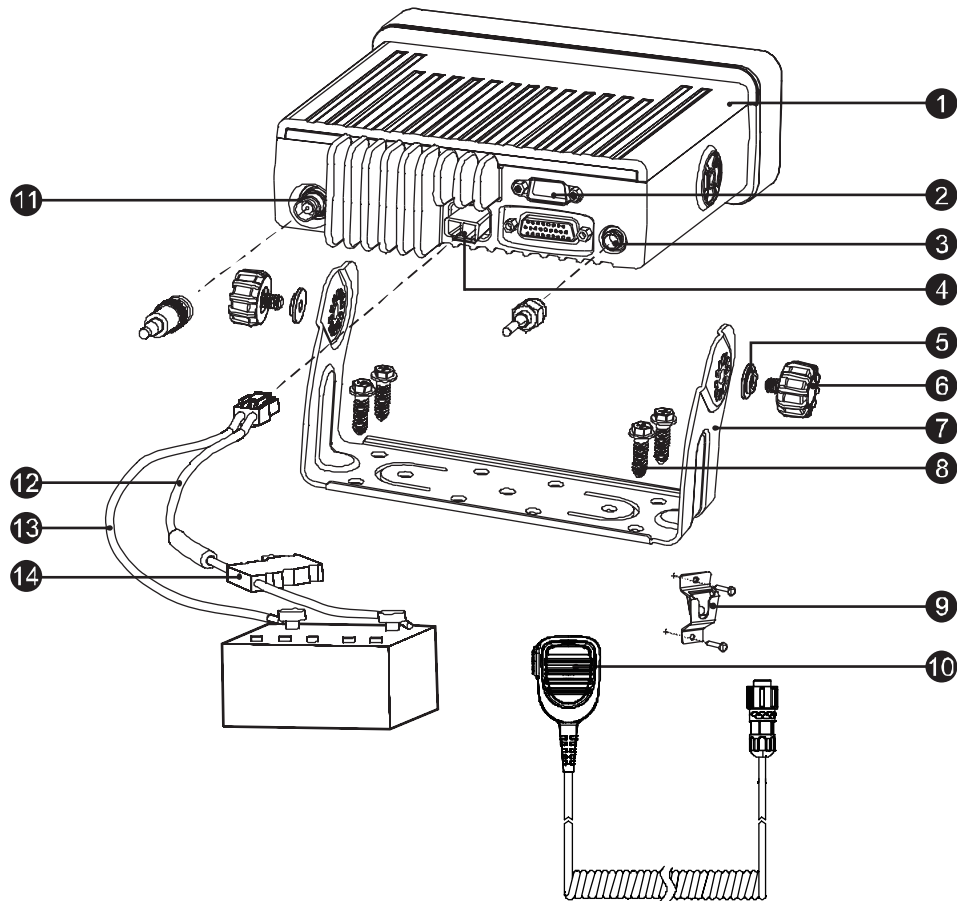

















- A. Install the bracket 7 with cross screw 8 in a proper position.
- B. Connect the accessories such as the radio antenna and power cord to the mobile 1.
- C. Slide the mobile radio 1 into the mounting bracket 7 and fix it with cross screw 6.
- D. Install the microphone hanger 9 in a location where it's easy to reach the microphone.
- E. Plug the handheld microphone 10 into the microphone jack on the front pannel of mobile radio 1 and place it on the hanger when you don't use it.



| Number | Name of Parts | Number | Name of Parts |
|--------|--------------------------------------|--------|-----------------------------|
| 1 | Mobile Radio | 2 | Accessory Interface |
| 3 | Positioning Module Antenna Interface | 4 | Power Supply Socket |
| 5 | Hardware Bracket knob underlay | 6 | Hardware Bracket knob |
| 7 | U-shaped Bracket | 8 | M6 Self-tapping Cross Screw |
| 9 | Handheld Microphone Hanger | 10 | Handheld Microphone |
| 11 | RF Antenna Base | 12 | Red Power Line |
| 13 | Black Power Line | 14 | Fuse |

Status Indication

LCD Icon

These icons may appear on LCD to help you easily identify the radio status.

| Icon Name | Icon | Radio Status |
|--------------------------|---|--|
| RSSI |  | No signal. |
| |  | More bars indicate better signal strength. |
| Message Icon |  | New message/unread message. |
| |  | InBox is full. |
| Working Mode Icon |  | Indicates in conventional mode. |
| |  | Indicates in trunking mode. |
| Power Level Icon |  | Indicates low-power transmission. |
| |  | Indicates mid-power transmission. |
| |  | Indicates high-power transmission. |
| Profiles Icon |  | Indicates the standard mode is enabled. |
| |  | Indicates the silenced mode is enabled. |
| |  | Indicates the custom mode is enabled. |
| Accessory Icon |  | Indicates the accessory is plugged in. |
| Handheld Microphone Icon |  | Indicates the handheld microphone is plugged in. |
| Call Status Icon |  | Indicates currently is talking. |
| |  | Indicates missed calls. |

| | | |
|--------------------------------|---|---|
| Channel / Group Selection Icon |  | Indicates in channel selection mode |
| Positioning Icon |  | The positioning feature is active, and valid positioning data is received. |
| |  | The positioning feature is active, but no valid positioning data is received. |

LED Indicator

The LED indicator will help you easily identify the current radio status.

| LED Indication | Radio Status |
|--------------------------------------|--------------|
| LED glows red | Transmitting |
| LED glows green | Receiving |
| LED glows green and flashing slowly. | Standby |

Basic Operations

Turning the Radio On / Off

Short press **[Power On / Off / On-hook]** button to turn on the radio, LCD displays power-up LOGO, and then enter the standby screen, and then long press **[Power On / Off / On-hook]** button to shutdown.

 Note: If a fault occurs and the radio does not turn off, you can press and hold the **[Power On / Off / On-hook]** button for more than 10 seconds with the forced shutdown and restart it.

Knob Switch Mode

Short press the knob ,to switch the two modes between volume and channel / group.

Radio Mode

The mobile terminal supports conventional and trunking mode, switching as below:

1. Press **[Option / Back / Home]** button to bring up the option menu;
2. Press **[Up] / [Down]** button to select 'Radio mode' and press **[Menu / Enter]** button to enter the list of radio mode;
3. Press **[Up] / [Down]** button to select 'Conventional' or 'Trunking' mode, press **[Menu / Enter]** button to switch modes.

 Note: In conventional mode the radio can communicate directly or via repeater inter-communicate; in trunking mode, the mobile terminal is connected by the base station, to realize the fuction of real-time dispatchment.

Adjusting the Volume

When the Volume Control / Channel Selector knob operates in volume adjustment mode, rotate the knob clockwise to increase the call volume, or counterclockwise to decrease volume.

Adjusting the Power Level

Press **[Power Level / Lock / Unlock]** button to change the transmitting power level to 'High / Mid / Low', and also the icon of the power level will be changed in the main menu.

Lock and Unlock

Long press **[Power Level / Lock / Unlock]** button can activating the keylock function, in case of wrong operation. Deactivate the keylock by long.

Switching Channel / Group

When in the channel / group switching mode, turn the knob to select channel / group.

In addition you can also switch the channel/group in the menu:

1. Press **[Option / Back / Home]** button to go to the 'Option' menu.
2. Press **[Up / Down]** button to select 'Channel Management / Group Management', press **[Enter]** to enter the channel / group folder list.
3. Press **[Up] / [Down]** button to select the channel / group folder, press **[Enter]** to enter the channel / group list.

4. Press **[Up]** / **[Down]** button to select the channel / group, press **[Enter]** button to switch channel / group.

 Note:

- 'Channel Management' and 'Group Management' are folders set up for classified management of channels and groups in conventional mode and trunking mode.
- This mobile terminal supports up to 64 channels / group folders, each folder contains up to 100 channels / groups, and please set it up via the dealer.

Call

Individual Call

■ Initiate the Individual Call

1. Input a individual call number you would like to call using the microphone with a keypad , or enter 'Phonebook' / 'Call Log' / 'Messages', to select the Contact / Messages;
2. Hold down the [PTT] button on the handheld microphone to transmit a individual call to the selected contact or message contact.

■ Receive and Call back

1. When the [PTT] button is idle ,without any actions of buttons ,the mobile radio could receive call.
2. You can hold down [PTT] button to call back after the calling party finish talking.

Group Call

The groups are preset by the dealer, operating method in conventional and trunking modes is the same.

■ Initiate group call

1. At standby screen, short press [Volume Control / Channel Selector] button, then rotate to select channel / group that willing to call.
2. Press [Enter] button to confirm the selected channel / group, or wait for it confirm automatically.
3. Hold down [PTT] button on handheld microphone to initiate group call.

■ Receive and Call back

1. When [PTT] button is idle ,without any actions of buttons ,the mobile radio could receive call.
2. You can hold down [PTT] button to call back after the calling party finish talking.

Telephone Call (Only in trunking mode)

The mobile terminal can be used to call the public telephone, provided the base station has realized a gateway interconnection between the intercom systems and telephone networks, for more related information, please contact your service provider.

■ Initiate telephone call

1. In trunking mode, input the gateway number and phone number through a handheld microphone with numeric keypad.
2. Press [PTT] button to initiate a call, there will be a waiting tone after connected, please wait for the response of called party .
3. When the called party receive the call ,you will hear its talk automatically, you must hold down [PTT] button to call back during the call.

■ Receive Telephone Call and Call back

Receive a telephone call in trunking mode is consistent with the process of receiving a normal call. For call back, hold down [PTT] button on the handheld microphone and speak to the microphone; release the [PTT] button, the phone call is automatically re-entered.

Emergency Call

Long press [Emergency Call] button to initiate an emergency call.

Menu Navigation

[Functions]

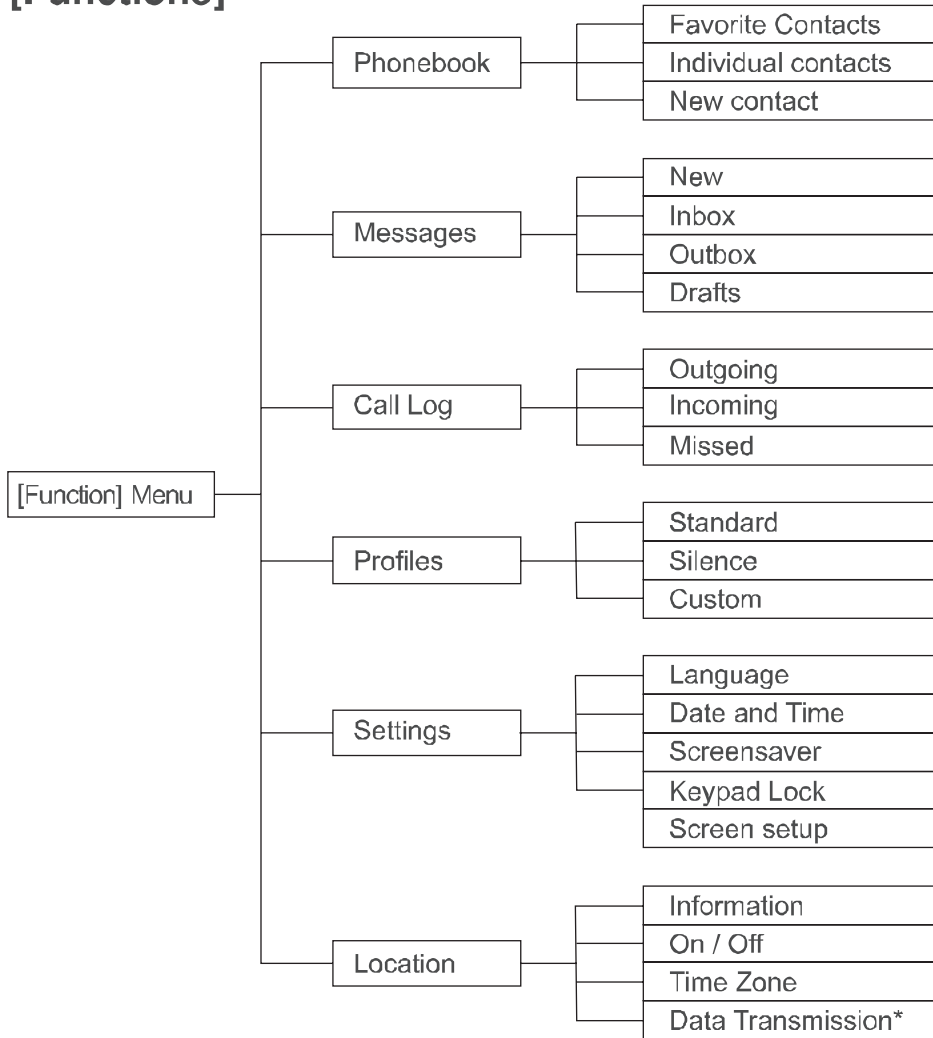

Phonebook

Phonebook is used to store contact information, press **[Menu / Enter]** button to open menu, press **[Up] / [Down]** button to select 'Phonebook', Press **[Menu / Enter]** button to get into it.

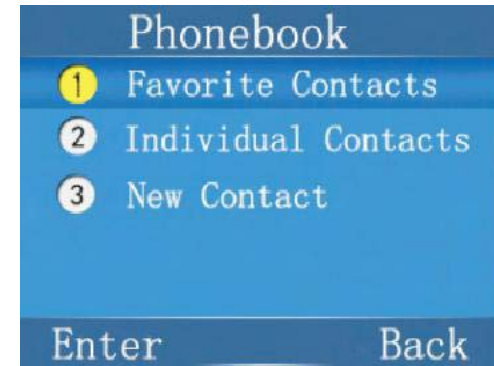

Phonebook includes three modules: Favorite Contacts, Individual Contacts, and New Contacts.

■ Favorite contacts

Save the individual contacts and group contacts that are frequently used, it could realize the following functions:

- Contact Add: Add the individual contacts and group contacts to your favorite contacts, for ease of use;
- Message: send message to the selected contacts;
- View: View the name and number of the contact;
- Contact Edit: Edit the name and number of the contact and save them;

- Delete: Delete a contact;
- Delete all: Delete all contacts.
- Call: Press the **[PTT]** button to call the selected contact.

■ Individual contacts

Save individual contacts, you can save up to 500 contacts; it could perform the same functions with favorite contracts:

- Message: send a message to the selected contact;
- View: view the name and number of the contact;
- Contact Edit: Edit the name and number of the contact and save;
- Delete: Delete a contact;
- Delete all: Delete all the contact information
- Call: Press **[PTT]** button to call the selected contact (or contacter ?)

■ New contacts

You can manually edit name and number of contact (or contacter ?) and save it in 'individual contacts'.

 Note:

- In addition to functions such as 'Contact Add' and 'Call', you have to select contacts in 'Favorite Contacts' or 'Individual Contacts', then press **[Menu / Enter]** button to use other functions.
- How to make call: Select a contact (or contacter?) in 'Favorite contacts' or 'Individual contacts',hold down **[PTT]** button to initiate the call to contact (or contacter?).

- Handheld microphone with keypad is required for 'New Contact' and 'Contact Edit', in the editing process, press **[#]** button on the keypad to switch input methods.

Messages

The mobile terminal can edit, send, and receive messages.

■ Edit and send message

1. At standby interface, press **[Menu / Enter]** button to open the menu, press **[Up] / [Down]** button to select 'Message', press **[Menu / Enter]** button to get into it.

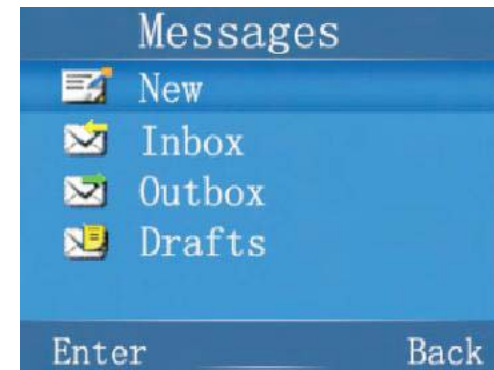

2. Select 'New' and press **[Menu / Enter]** button to enter message type selection interface.

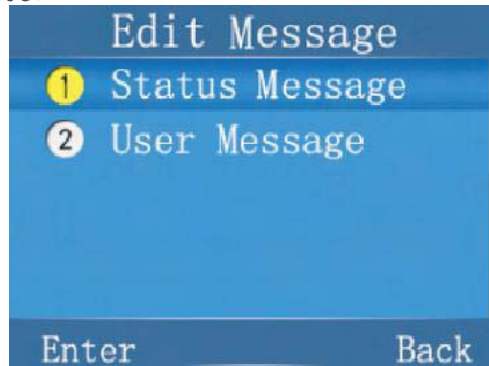

3. Press **[Up]** / **[Down]** button to select 'Status Message' or 'User Message' and then press **[Menu / Enter]** button to enter edit message interface.

 Note: 'Status Message' is pre-programmed by the dealer, you can only read and use it.

4. After select status message or finish editing user message, press **[Menu/Enter]** button to enter interface of recipients.



5. Input the Tel number, or select contact (or contacter?) from 'Favorite contacts', 'Individual contacts', 'Group contacts', then press **[Menu / Enter]** button to send message.

■ Receive Messages

After receiving a new message, the icon  will display in the status bar. Press **[Menu / Enter]** button to read message immediately or press **[Option / Back / Home]** button to keep view later.

If the Inbox is full of unread messages, the icon  will display in the status bar, then you need to clear your inbox, in order to continue receiving messages.

■ Inbox

The received messages are stored in the inbox, and it can store not more than 50 messages.

In the Inbox, it displays a list of messages, it could realize the following functions:

- View: View the contents of the selected message.
- Reply: Reply to the sender.
- Forward: Forwards the message to others.
- Extract Numbers: Extract the sender's number from the message and save it in Phonebook.
- Delete: Delete the selected message.
- Delete All: Delete all messages received.
- Call: Press **[PTT]** button to call the sender.

■ Outbox

The Message which sent out successfully will be saved in the Outbox. The Outbox can store up to 50 messages.

In the Inbox it displays a list of messages, it could realize the following functions:

- View: View the contents of the selected message.
- Resend: Resend this message.
- Edit: Edit the contents of the message and resend it.
- Extract Numbers: Extract the sender's number in the message and save it in phonebook.
- Delete: Delete the selected message.
- Delete All: Delete all the messages send.
- Call: Press **[PTT]** button to call the recipient.

■ Draft

In the process of editing the message, press **[Power On / Off / On-hook]** button to exit message editing and return to standby interface, the message is saved in Drafts, it can store up to 50 messages.

When you enter the Draft, it displays the message list, it could realize the following functions:

- View: View the contents of the selected draft.
- Edit: Edit the contents of the draft and resend it.
- Delete: Delete the selected draft.
- Delete All: Delete all messages in the Draft.
- Call: Press **[PTT]** button to call the recipient.

Call Log

Call Log includes Outgoing / Incoming / Missed calls, each option can save up to 50 entries.

After selecting the Call Log, it could realize the following functions:

- Message: Send a message to the number that the call log contains.
- Detail: View Name, Tel, Time of selected call log.
- Save: Save the number that is contained in the Call Log.
- Delete: Delete this call log.
- Delete All: Deletes all call log.
- Call: Press **[PTT]** button to call the number that the selected call log contains.

Profiles

Profiles including 3 modes of Standard / Silence / Custom.

- Standard: Voice reminder when pressing buttons, call reminder, turn on / off etc.
- Silent: No voice reminder when pressing buttons, call reminder, turn on / off etc.
- Custom: Setting the voice reminder manually. You can disable or enable the voice reminder of pressing buttons, call reminder, turn on / off etc.

 Note: Select the 'Custom' mode, enter by long press the **[Menu/Enter]** button.

Settings

■ Language

This option allows you to switch among different languages and mobile terminal supports three languages: English / Spanish / Chinese.

■ Time and Date

You can set the date and time of the terminal via this option.

After entering the 'Time and Date', press the **[Menu / Enter]** button to change the input term. And press **[Up]** / **[Down]** button to modify the value; at last input term, press **[Menu / Enter]** button to save time and date.

■ Keypad Lock

Turn on / off the function of keypad lock. The function of keypad lock will enable automatically after setting time.

■ Screensaver

Activate or deactivate the screensaver. If you activate the screen saver, after the pre-set time, the screen saver will start automatically.

 Note: Before the screen saver started, press any button, the screen saver chronograph is cleared, and then the timer is reset.

■ Screen Setup

Includes two settings: 'Brightness' and 'Backlight Time out'.

You can adjust the brightness of the screen by pressing **[Up]** and **[Down]** button and pressing **[Menu / Enter]** to save the settings.

You can turn on and off the backlight delay, if it is activated, when the set time is over, the backlight turns off, incoming call or press any button can turn on backlight;; if the function is turned off, the backlight is always on.

Location

■ Information

It includes date, time, longitude, latitude, number of satellites. Date and time are related to the time zone configuration of the terminal.

■ On / Off

You can enable / disable the positioning function.

■ Time Zone

Set time zone according to the location of mobile terminal to synchronize the time. There are 24 time zone options.

■ Data transmission *

This function is combined with the sending method and it is used for sending the current position information of this terminal to the other terminals or control centers. It could be sent to individuals and group.

[Options]

The Options menu includes the following functions:

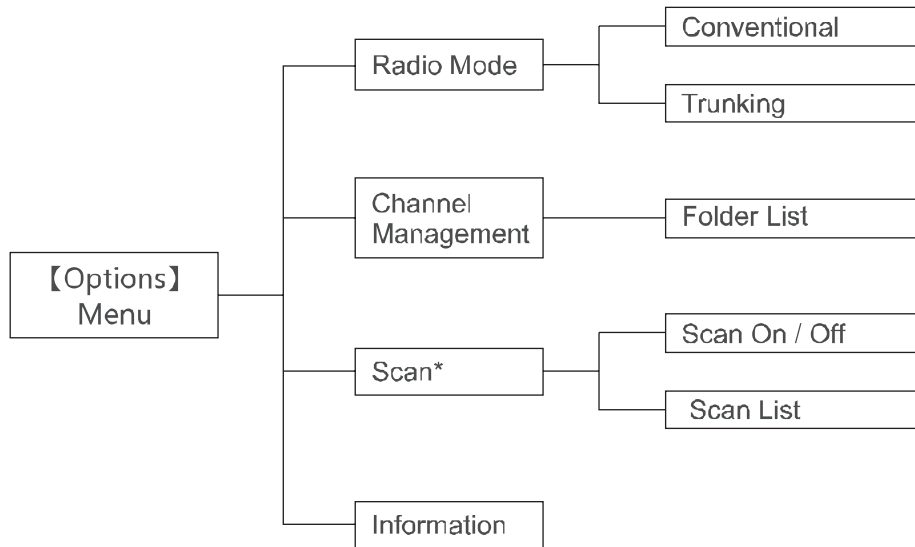

Radio Mode

'Conventional' and 'Trunking' mode can be setted.

Channel Management

In the folder, user can view all the channels' information and switch to the selected channel by press **[Menu / Enter]** button.

 Note: In trunking mode, The folder is not for the channels but for calling groups, so the name was changed to 'Group Management' and

its contents have changed to groups.

Scan*

The Scan feature allows you to listen to communication activities on other channels so that you can keep a close track of your team members.

■ Scan On / Off

You can enable or disable scan function through this option.

■ Scan List

You can request your dealer to create a scan list for each channel. Each list may contain 32 channels at most (either digital channel or analog channel is OK). After accessing the list, you can perform any of the following operations:

- Add Channel

In the folder of channels, select the channels to add to the current scan list.

- Delete Channel

You can delete the channel of the scan list, except the first channel of the scan list.

 Note: In trunking mode, there is no scan module.

Information

View information about the mobile terminal: BAND, ISSI, Version.

Troubleshooting

| Phenomena | Analysis | Solution |
|--|--|--|
| The radio can't be powered on. | The power cord is not connected or the contact with the socket is too loose. | Properly connect the power cord correctly and ensure good contact. |
| | The fuse in the power cord is damaged. | Check whether the fuse in the DC power cable is burned, if it is burned, please replace with a new fuse. |
| | The power connection of plus or minus pole is wrong. | Check whether the fuse in the DC power cable is burned. And Connect the power of plus or minus pole in right position, turn on the radio. |
| Unable to establish a call. | The signal is weak. | Make sure the mobile terminal is within the effective signal range of the base station. |
| | The parameters of used frequency and channel are incorrect. | Switch to the correct channel. |
| You can't register. | It can't receive the signal from the base station. | Make sure the mobile terminal is within the effective signal range of the base station. |
| | It's illegitimate user of the base station, you can't register. | Contact the person responsible for the base station to confirm whether this unit is legitimate user of the network management system base station. |
| Repeated registration | Intermittent signals. | Make sure the mobile terminal is within the effective signal range of the base station. |
| It is switched off repeatedly during the calls. | It is too far, and the signal is weak. | Make sure the mobile terminal is within the effective signal range of the base station or move towards to other members. |
| When it is called upon, the sound is small, intermittent or unclear. | The volume is small. | Increase the volume via the knob. |
| | It is too far, and the signal is weak. | Make sure the mobile terminal is within the effective signal range of the base station or move towards to other members. |
| | The antenna is loose or the interface is damaged. | Check interface and tighten the connector, if necessary, replaced by a new connector. |
| | The installation is not adequate. | Remove the antenna after switching off the terminal and reinstall it, and then turn on the terminal. |
| | The connecting cable is damaged, there is signal energy leakage. | Check the level of damage or replace it if necessary. |

| | | |
|---------------------------------------|--|---|
| | The speaker is blocked or damaged. | Make a simple exterior cleaning, if still not solve the problem. please contact your dealer or our designated repairing points for repairs. |
| There is no connection during a call. | You may be in an unfavorable position. For example, high buildings or underground areas. | Move to an open and flat area, and restart the radio. |
| | The distance of communication with other members is too far. | Move towards to other members. |
| The noise is too loud. | You may be in an unfavorable position. For example, communication can be blocked by tall buildings or frustrated in the underground areas. | Move to an open and flat area, and restart the radio. |
| | You might suffer from external shock (such as electromagnetic interference). | Stay away from equipments that may cause interference. |
| You can't use the keys. | The keyboard may not work temporarily. | Restart the radio. |
| | The connection of handheld microphone is not stable. | Check the connection of the handheld microphone. |
| The LCD display shows no information. | The LCD screen may not work temporarily. | Turn off the terminal and wait for a moment and restart it. |

If the above solutions can't fix your problems, or you may have other questions, please contact your local dealer or us for technical support.

Care and Cleaning

To guarantee optimal performance as well as a long service life of the product, please follow the tips below.

Routine Maintenance

- Keep the product in a place with good ventilation and heat dissipation to facilitate normal work.
- Do not put irrelevant items on top of the product to ensure optimal heat dissipation.
- Do not puncture or scrape the product.
- Do not place the product in the environment with electronic circuits or corrosive substances.
- Do not place the product in corrosive agents, solutions or water.

Cleaning

- Clean up the dust and fine particles on the surface of the product with a soft, clean, dry lint or brush regularly to keep them clean and prevent bad contact.
- Use a nonwoven fabric with neutral cleaner to clean the keys, control knobs, display and interfaces if they are dirty. Do not use corrosive chemicals such as stain removers, alcohols, aerosols or petroleum products. After cleaning, make sure that the product is completely dry before use, otherwise, do not use it.

 Caution: Turn off the product before cleaning.

Quality Assurance and Maintenance Terms

Shenzhen Samhoo SCI & TECH CO.,LTD (hereinafter referred to as Samhoo) promise that if the radios produced by Samhoo, since the date of purchase,under the condition of normal use,operation and maintenance,show defects in the material or manufacturing technology,you will get the following warranty service.

1.Warranty Range and Duration

Radio unit: 24 months.

The standard accessories (including handheld microphone and cable): 12 months.

2.Conditions of Warranty:

If you apply for the warranty services of Samhoo products, please provide a valid warranty card or the original invoice. During the warranty period,the related marks of Samhoo products, such as the serial number, should be maintained clear and complete and not be torn up.

- 1) The warranty card should be completely filled in and stamped by Samhoo or the authorized dealers. The contents on the warranty card should include the product name, manufacturing serial number, date of purchase, marketing unit and so on.
- 2) The effective invoice should be supervised by the fiscal and taxation departments and it is an important voucher.The filling content on the invoice should include the product name, manufacturing serial number, date of purchase,amount of purchase and so on.

 Attention:

- This product must be sent back to the headquarters of the service center or our overseas service station for the repair.
- Waterproof Terminals (waterproof level up to 6 and above) must be returned to our customer service at headquarters, our foreign repair station or through our authorized dealer service stations for repairing.
- Please pack the product well with the required documents and detailed description of malfunction and send to the after-sales service center of our company or the designated service stations. You can also get assist by dial our service hotline:
0086-755 8316 0260

3.The terms of this service do not include the following contents:

- 1) Beyond the valid period of warranty.
- 2) The malfunction or damage is caused by the use or maintenance which are not following the specification.
- 3) The malfunction or damage is caused by the abnormal or unconventional use.
- 4) The malfunction or damage is caused by the modification, change, removal, using non-original attachments or batteries, or upgrading the software and removing firmware without Samhoo's authorization.
- 5) The fault or damage to the antenna is not caused by the materials or processing methods.
- 6) The related marks on the radio are torn up or erased, the serial

number cannot be identified.

- 7) The products whose purchase date cannot be identified.
- 8) The malfunction or damage caused by the force majeure.
- 9) The normal and conventional abrasion.

Special Notes:

1. Within the limits of law, in any case, Samhoo has no liability for the loss that is more than the product purchase price, meanwhile, Samhoo is not liable for any loss of use, loss of time, loss of business, loss of profits or income, and the incidental, special or secondary damage.
2. Since the environment or systems of using the product are different, Samhoo is not responsible for the coverage area of the whole system or the operation conditions.
3. The maintenance clauses are enacted in accordance with relevant national warranty regulations. Due to the technical development and market adjustment, the clauses will be changed accordingly. The specific changes are subject to Change Notice issued by Samhoo customer service center. For any other matters that are not mentioned here, it will be subject to relevant national regulations.

Samhoo

is registered trademark of SAMHOO SCI & TECH CO.,LTD.
and is under authorized use.

© Copyright 2013 SAMHOO SCI & TECH CO.,LTD.

All rights reserved.

SHENZHEN SAMHOO SCI & TECH CO.,LTD.

Address: Huaqiangyun Industrial Park, No.1-1 Meixiu Road ,
Meilin Industrial Park, Futian Distric, Shenzhen, China.

Service hotline: 086-755 8316 0260

Postcode: 518049

Website: www.samhoo-pmr.com

ISO9001:2008&ISO14001:2004