

RADIO TEST REPORT
For
SHENZHEN SAMHOO SCI&TECH CO.,LTD
Digital Two-Way Radio
Test Model: SPH6050S

Prepared for : SHENZHEN SAMHOO SCI&TECH CO.,LTD
Address : Room 401, Building 2th, Huaqiangyun Industrial Park, Meixiu Road, Meilin, Futian District, Shenzhen, China

Prepared by : Shenzhen LCS Compliance Testing Laboratory Ltd.
Address : 1/F., Xingyuan Industrial Park, Tongda Road, Bao'an Avenue, Bao'an District, Shenzhen, Guangdong, China

Tel : (+86)755-82591330
Fax : (+86)755-82591332
Web : www.LCS-cert.com
Mail : webmaster@LCS-cert.com

Date of receipt of test sample : April 07, 2016
Number of tested samples : 1
Serial number : Prototype
Date of Test : April 07, 2016 ~ May 10, 2016
Date of Report : May 10, 2016

RADIO TEST REPORT
FCC Part 90

Report Reference No. : **LCS1604070496E**

Date of Issue : May 10, 2016

Testing Laboratory Name : **Shenzhen LCS Compliance Testing Laboratory Ltd.**

Address : 1/F., Xingyuan Industrial Park, Tongda Road, Bao'an Avenue,
Bao'an District, Shenzhen, Guangdong, China

Testing Location/ Procedure : Full application of Harmonised standards
Partial application of Harmonised standards
Other standard testing method

Applicant's Name..... : **SHENZHEN SAMHOO SCI&TECH CO.,LTD**

Address : Room 401, Building 2th, Huaqiangyun Industrial Park, Meixiu
Road, Meilin, Futian District, Shenzhen, China

Test Specification

Standard : FCC Part 90/FCC Part 2/FCC Part 15B

Test Report Form No. : LCSEMC-1.0

TRF Originator : Shenzhen LCS Compliance Testing Laboratory Ltd.

Master TRF : Dated 2011-03

Shenzhen LCS Compliance Testing Laboratory Ltd. All rights reserved.

This publication may be reproduced in whole or in part for non-commercial purposes as long as the Shenzhen LCS Compliance Testing Laboratory Ltd. is acknowledged as copyright owner and source of the material. Shenzhen LCS Compliance Testing Laboratory Ltd. takes no responsibility for and will not assume liability for damages resulting from the reader's interpretation of the reproduced material due to its placement and context.

Test Item Description. : **Digital Two-Way Radio**

Trade Mark..... : Samhoo

Test Model : SPH6050S

Ratings : DC 7.4V by Lithium ion polymer battery(2250mAh)
Recharge Voltage: DC 12V/1A

Result : **Positive**

Compiled by:

Aking Jin

Aking Jin/ File administrators

Supervised by:

Glin Lu

Glin Lu/ Technique principal

Approved by:

Gavin Liang

Gavin Liang/ Manager

RADIO -- TEST REPORT

Test Report No. : LCS1604070496E	<u>May 10, 2016</u> Date of issue
---	--------------------------------------

Test Model.....	: SPH6050S
EUT.....	: Digital Two-Way Radio
Applicant.....	: SHENZHEN SAMHOO SCI&TECH CO.,LTD
Address.....	: Room 401, Building 2th, Huaqiangyun Industrial Park, Meixiu Road, Meilin, Futian District, Shenzhen, China
Telephone.....	: +86-0755 8226 7833
Fax.....	: +86-0755 8226 3733
Manufacturer.....	: SHENZHEN SAMHOO SCI&TECH CO.,LTD
Address.....	: Room 401, Building 2th, Huaqiangyun Industrial Park, Meixiu Road, Meilin, Futian District, Shenzhen, China
Telephone.....	: +86-0755 8226 7833
Fax.....	: +86-0755 8226 3733
Factory.....	: SHENZHEN SAMHOO SCI&TECH CO.,LTD
Address.....	: Room 401, Building 2th, Huaqiangyun Industrial Park, Meixiu Road, Meilin, Futian District, Shenzhen, China
Telephone.....	: +86-0755 8226 7833
Fax.....	: +86-0755 8226 3733

Test Result	Positive
--------------------	-----------------

The test report merely corresponds to the test sample.
 It is not permitted to copy extracts of these test result without the written permission of the test laboratory.

Revision History

Revision	Issue Date	Revisions	Revised By
00	2016-05-10	Initial Issue	Gavin Liang

TABLE OF CONTENTS

1. GENERAL INFORMATION	6
1.1. PRODUCT DESCRIPTION FOR EQUIPMENT UNDER TEST (EUT)	6
1.2. OBJECTIVE	6
1.3. RELATED SUBMITTAL(S)/GRANT(S).....	7
1.4. DESCRIPTION OF TEST FACILITY	7
1.5. SUPPORT EQUIPMENT LIST	7
1.6. EXTERNAL I/O	7
1.7. MEASUREMENT UNCERTAINTY.....	7
1.8. TEST ENVIRONMENT	8
1.9. DESCRIPTION OF TEST MODES	8
2. SYSTEM TEST CONFIGURATION	8
2.1. JUSTIFICATION	8
2.2. EUT EXERCISE SOFTWARE	9
2.3. SPECIAL ACCESSORIES.....	9
2.4. BLOCK DIAGRAM/SCHEMATICS	9
2.5. EQUIPMENT MODIFICATIONS	9
2.6. CONFIGURATION OF TEST SETUP	9
3. SUMMARY OF TEST RESULT.....	10
4. TEST CONDITIONS AND RESULTS.....	11
4.1. CONDUCTED EMISSIONS TEST.....	11
4.2. OCCUPIED BANDWIDTH AND EMISSION MASK TEST.....	15
4.3. TRANSMITTER RADIATED SPURIOUS EMISSION	24
4.4. SPURIOUS EMISSION ON ANTENNA PORT	29
4.5. MODULATION CHARACTERISTICS	43
4.6. FREQUENCY STABILITY TEST.....	47
4.7. MAXIMUM TRANSMITTER POWER.....	49
4.8. TRANSMITTER FREQUENCY BEHAVIOR	56
5. LIST OF MEASURING EQUIPMENT.....	60

1. GENERAL INFORMATION

1.1. Product Description for Equipment Under Test (EUT)

EUT	: Digital Two-Way Radio
Test Model	: SPH6050S
Power Supply	: DC 7.4V by Lithium ion polymer battery(2250mAh) Recharged by DC 12V/1000mA
Hardware Version	: SPH6000V3.0
Software Version	: V1.02.01.006B
Frequency Range	: 450MHz-520MHz
Channel Separation	: Analog Voice 12.5KHz Digital Voice/Data 12.5KHz Digital Data 12.5KHz
Modulation Type	: FM for Analog Voice 4FSK for Digital Voice/Digital Data 4FSK for Digital Data 11K0F3E for FM Modulation at 12.5KHz Channel Separation
Emission Designator	: 7K60FXD for Digital Data at 12.5KHz Channel Separation 7K60FXW for Digital Data & Digital Voice at 12.5KHz Channel Separation
Antenna Description	: External, 1.0dBi (Max)
Rated Power	: 4Watts/1Watts
GPS Receiver	:
Receive Frequency	: 1575.42MHz
Channel Number	: 1

Note: The product has the same digital working characters when operating in both two digitized voice/data mode. So only one set of test results for digital modulation modes are provided in this test report.

1.2. Objective

The tests were performed according to following standards:

[FCC Rules Part 90: 2015](#): PRIVATE LAND MOBILE RADIO SERVICES.

[47 CFR FCC Part 15 Subpart B: 2015](#) - Unintentional Radiators

[FCC Part 2](#): FREQUENCY ALLOCA-TIONS AND RADIO TREATY MAT-TERS; GENERAL RULES AND REG-ULATIONS

[TIA/EIA 603 D: June 2014](#): Land Mobile FM or PM Communications Equipment Measurement and Performance Standards.

1.3. Related Submittal(s)/Grant(s)

No Related Submittals.

1.4. Description of Test Facility

CNAS Registration Number. is L4595.

FCC Registration Number. is 899208.

Industry Canada Registration Number. is 9642A-1.

VCCI Registration Number. is C-4260 and R-3804.

ESMD Registration Number. is ARCB0108.

UL Registration Number. is 100571-492.

TUV SUD Registration Number. is SCN1081.

TUV RH Registration Number. is UA 50296516-001

1.5. Support equipment List

Manufacturer	Description	Model	Serial Number	Certificate
XING YUAN ELECTRONICS CO.,LTD	Adapter	XY-1201000-E	--	CE
SHENZHEN SAMHOO SCI&TECH CO.,LTD	Adapter	DC100000	--	CE

1.6. External I/O

I/O Port Description	Quantity	Cable
Micro SD Card Slot	1	N/A
Accessory Jack	1	N/A
Battery Pole Piece	1	N/A

1.7. Measurement Uncertainty

Where relevant, the following measurement uncertainty levels have been estimated for tests performed on the apparatus:

Test Items	Measurement Uncertainty	Notes
Frequency stability	30 Hz	(1)
Transmitter power conducted	0.62 dB	(1)
Transmitter power Radiated	2.67 dB	(1)
Conducted spurious emission 9KHz-40 GHz	1.88 dB	(1)
Conducted Emission 9KHz-30MHz	1.63 dB	(1)
Radiated Emission 30~1000MHz	4.65 dB	(1)
Radiated Emission 1~18GHz	3.89 dB	(1)
Radiated Emission 18-40GHz	3.90 dB	(1)
Occupied Bandwidth	-----	(1)
Emission Mask	-----	(1)
Modulation Characteristic	-----	(1)
Transmitter Frequency Behavior	-----	(1)

(1) This uncertainty represents an expanded uncertainty expressed at approximately the 95% confidence level using a coverage factor of $k=1.96$.

1.8. Test Environment

Items	Required (IEC 68-1)	Actual
Temperature (°C)	15-35	21
Humidity (%RH)	25-75	50
Barometric pressure (mbar)	860-1060	950-1000

1.9. Description Of Test Modes

The EUT has been tested under typical operating condition and The Transmitter was operated in the normal operating mode. The TX frequency was fixed which was for the purpose of the measurements.

EUT operation mode no.	Description of operation mode	Additional information
Op 1	FM+BW12.5KHz+TX	The equipment is set with FM modulation and 12.5KHz bandwidth at maximum rated power for transmitter, powered by DC 7.40V
Op 2	FM+BW12.5KHz+TX	The equipment is set with FM modulation and 12.5KHz bandwidth at minimum rated power for transmitter, powered by DC 7.40V
Op 3	4FSK+BW12.5KHz+TX	The equipment is set with 4FSK modulation and 12.5KHz bandwidth at maximum rated power for transmitter, powered by DC 7.40V
Op 4	4FSK+BW12.5KHz+TX	The equipment is set with 4FSK modulation and 12.5KHz bandwidth at minimum rated power for transmitter, powered by DC 7.40V
Op 5	FM+BW12.5KHz+RX (Standby)	The equipment is set with FM modulation and 12.5KHz bandwidth at Receiver/Standby mode, powered by DC 7.40V(or for charging mode for AC conducted emission)
Op 6	4FSK+BW12.5KHz+RX (Standby)	The equipment is set with 4FSK modulation and 12.5KHz bandwidth at Receiver/Standby mode, powered by DC 7.40V(or for charging mode for AC conducted emission)

Test frequency list

Modulation Type	Channel Separation	Test Channel	Test Frequency (MHz)	
			TX	RX
Analog/FM	12.5KHz	Ch1	450.025	450.025
		Ch2	467.775	467.775
		Ch3	511.9875	511.9875
Digital/4FSK	12.5KHz	Ch4	450.025	450.025
		Ch5	467.775	467.775
		Ch6	511.9875	511.9875

2. SYSTEM TEST CONFIGURATION

2.1. Justification

The system was configured for testing in engineering mode.

2.2. EUT Exercise Software

N/A.

2.3. Special Accessories

N/A.

2.4. Block Diagram/Schematics

Please refer to the related document.

2.5. Equipment Modifications

Shenzhen LCS Compliance Testing Laboratory Ltd. has not done any modification on the EUT.

2.6. Configuration of Test Setup

Please refer to the test setup photo.

3. SUMMARY OF TEST RESULT

Test specification clause	Test case	Verdict
FCC Part 15.107	Conducted Emission	PASS
FCC Part 90.205	Maximum Transmitter Power	PASS
FCC Part 90.207	Modulation Characteristic	PASS
FCC Part 90.209	Occupied Bandwidth	PASS
FCC Part 90.210	Emission Mask	PASS
FCC Part 90.213	Frequency Stability	PASS
FCC Part 90.214	Transmitter Frequency Behavior	PASS
FCC Part 90.210	Transmitter Radiated Spurious Emission	PASS
FCC Part 90.210	Spurious Emission On Antenna Port	PASS

Remark:

1. The measurement uncertainty is not included in the test result.

4. TEST CONDITIONS AND RESULTS

4.1. Conducted Emissions Test

TEST APPLICABLE

The EUT was tested according to ANSI C63.4 - 2014. The frequency spectrum from 0.15 MHz to 30 MHz was investigated. The LISN used was 50 ohm / 50 u Henry as specified by section 5.1 of ANSI C63.4 - 2014. Cables and peripherals were moved to find the maximum emission levels for each frequency.

TEST CONFIGURATION

For AC Power

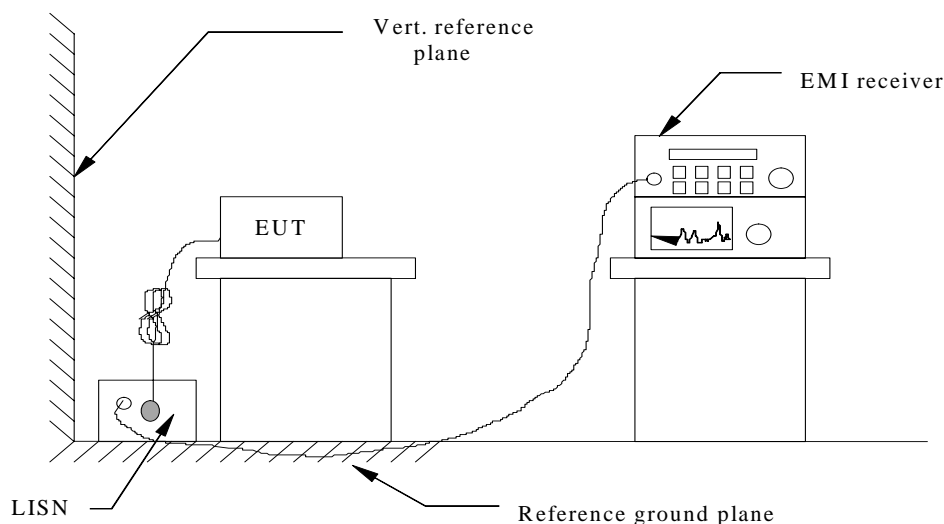

TEST PROCEDURE

- 1 The equipment was set up as per the test configuration to simulate typical actual usage per the user's manual. The EUT is a tabletop system; a wooden table with a height of 0.8 meters is used and is placed on the ground plane as per ANSI C63.4-2014.
- 2 Support equipment, if needed, was placed as per ANSI C63.4-2014.
- 3 All I/O cables were positioned to simulate typical actual usage as per ANSI C63.4-2014.
- 4 If a EUT received AC120V/60Hz power through a Line Impedance Stabilization Network (LISN) which supplied power source and was grounded to the ground plane.
- 5 If a EUT received DC 13.60V power through an Impedance Stabilization Network (ISN) which supplied power source and was grounded to the ground plane.
- 6 All support equipments received AC power from a second LISN, if any.
- 7 The EUT test program was started. Emissions were measured on each current carrying line of the EUT using a spectrum Analyzer / Receiver connected to the LISN powering the EUT. The LISN has two monitoring points: Line 1 (Hot Side) and Line 2 (Neutral Side). Two scans were taken: one with Line 1 connected to Analyzer / Receiver and Line 2 connected to a 50 ohm load; the second scan had Line 1 connected to a 50 ohm load and Line 2 connected to the Analyzer / Receiver.
- 8 Analyzer / Receiver scanned from 150 KHz to 30MHz for emissions in each of the test modes.

9 During the above scans, the emissions were maximized by cable manipulation.

Conducted Power Line Emission Limit

For intentional device, according to § 15.207(a) and RSS-Gen Section 7.2.4 for AC Power Conducted Emission Limits is as following:

Frequency (MHz)	Maximum RF Line Voltage (dB μ V)			
	CLASS A		CLASS B	
	Q.P.	Ave.	Q.P.	Ave.
0.15 - 0.50	79	66	66-56*	56-46*
0.50 - 5.00	73	60	56	46
5.00 - 30.0	73	60	60	50

* Decreasing linearly with the logarithm of the frequency

TEST RESULTS

Remark: we tested all Op 5 to Op 6, recorded worst case at Op 5.

Op 1
 Test Result for Line Power Input AC 240V/60Hz

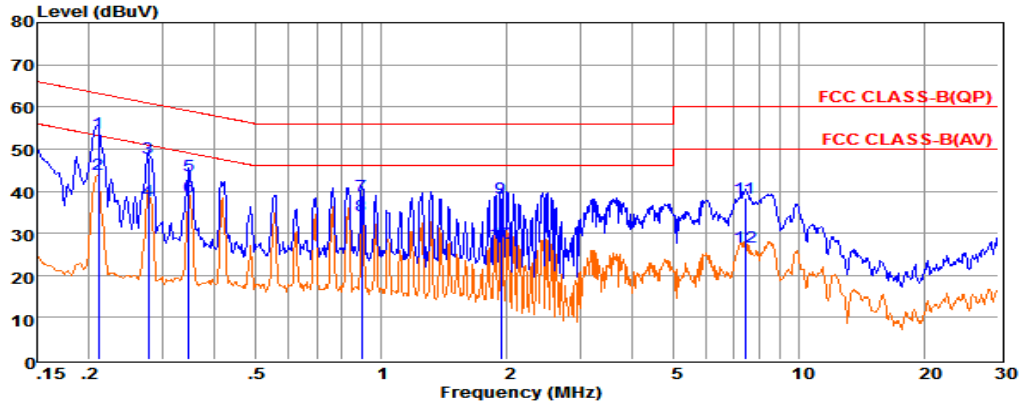

Env. Ins: 24*/56%
 Pol: LINE

Freq	Reading	LisnFac	CabLos	Atten_Fac	Measured	Limit	Over	Remark
MHz	dBuV	dB	dB	dB	dBuV	dBuV	dB	
1 0.21055	34.05	9.63	0.03	10.00	53.71	63.18	-9.47	QP
2 0.21065	24.40	9.63	0.03	10.00	44.06	53.18	-9.12	Average
3 0.27734	28.10	9.63	0.03	10.00	47.76	60.90	-13.14	QP
4 0.27744	17.96	9.63	0.03	10.00	37.62	50.89	-13.27	Average
5 0.34646	23.93	9.62	0.03	10.00	43.58	59.05	-15.47	QP
6 0.34656	18.88	9.62	0.03	10.00	38.53	49.04	-10.51	Average
7 0.89917	19.38	9.63	0.05	10.00	39.06	56.00	-16.94	QP
8 0.89927	14.67	9.63	0.05	10.00	34.35	46.00	-11.65	Average
9 1.93860	18.81	9.64	0.05	10.00	38.50	56.00	-17.50	QP
10 1.93960	8.07	9.64	0.05	10.00	27.76	46.00	-18.24	Average
11 7.44647	18.61	9.68	0.07	10.00	38.36	60.00	-21.64	QP
12 7.44747	7.04	9.68	0.07	10.00	26.79	50.00	-23.21	Average

Remarks: 1. Measured = Reading + Lisn Factor +Cable Loss+Atten_Fac.
 2. The emission levels that are 20dB below the official limit are not reported.

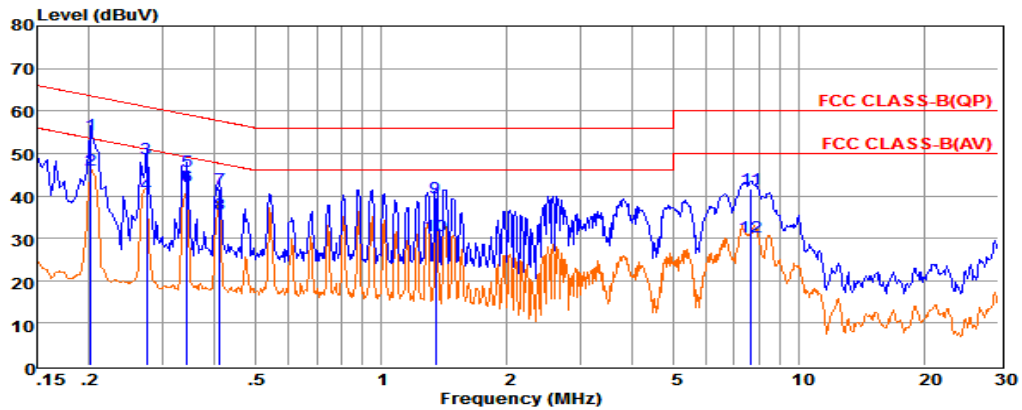

Env. Ins: 24*/56%
 Pol: NEUTRAL

Freq	Reading	LisnFac	CabLos	Atten_Fac	Measured	Limit	Over	Remark
MHz	dBuV	dB	dB	dB	dBuV	dBuV	dB	
1 0.20181	34.87	9.59	0.02	10.00	54.48	63.54	-9.06	QP
2 0.20191	26.44	9.59	0.02	10.00	46.05	53.53	-7.48	Average
3 0.27442	29.10	9.60	0.03	10.00	48.73	60.98	-12.25	QP
4 0.27452	20.96	9.60	0.03	10.00	40.59	50.98	-10.39	Average
5 0.34281	26.22	9.61	0.03	10.00	45.86	59.13	-13.27	QP
6 0.34291	22.48	9.61	0.03	10.00	42.12	49.13	-7.01	Average
7 0.41048	22.11	9.61	0.04	10.00	41.76	57.64	-15.88	QP
8 0.41058	15.95	9.61	0.04	10.00	35.60	47.64	-12.04	Average
9 1.35213	19.88	9.63	0.05	10.00	39.56	56.00	-16.44	QP
10 1.35313	10.82	9.63	0.05	10.00	30.50	46.00	-15.50	Average
11 7.68699	21.75	9.70	0.07	10.00	41.52	60.00	-18.48	QP
12 7.68799	10.65	9.70	0.07	10.00	30.42	50.00	-19.58	Average

Remarks: 1. Measured = Reading + Lisn Factor +Cable Loss+Atten_Fac.
 2. The emission levels that are 20dB below the official limit are not reported.

Test Result for Line Power Input AC 120V/60Hz

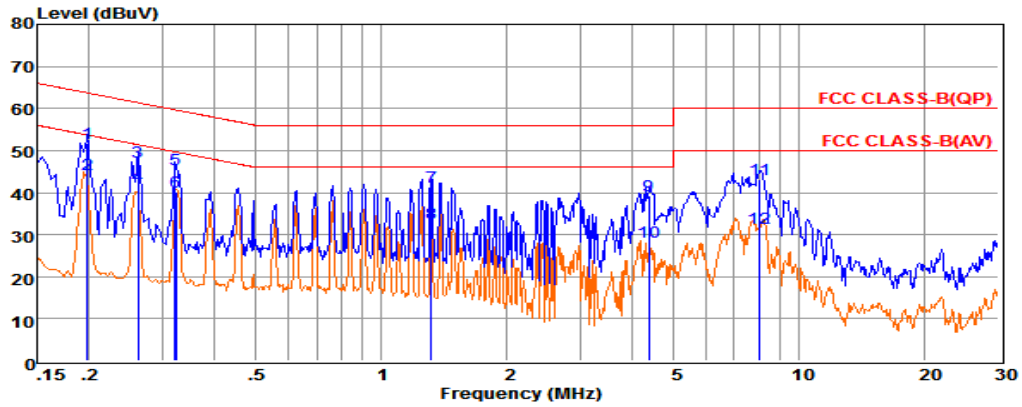

Env. Ins: 24*/56%
 Pol: NEUTRAL

	Freq	Reading	LisnFac	CabLos	Atten_Fac	Measured	Limit	Over	Remark
	MHz	dBuV	dB	dB	dB	dBuV	dBuV	dB	
1	0.19758	32.25	9.59	0.02	10.00	51.86	63.71	-11.85	QP
2	0.19768	24.72	9.59	0.02	10.00	44.33	53.71	-9.38	Average
3	0.26164	27.69	9.60	0.03	10.00	47.32	61.38	-14.06	QP
4	0.26174	21.93	9.60	0.03	10.00	41.56	51.38	-9.82	Average
5	0.32169	25.79	9.61	0.03	10.00	45.43	59.66	-14.23	QP
6	0.32179	20.44	9.61	0.03	10.00	40.08	49.66	-9.58	Average
7	1.31678	21.59	9.63	0.05	10.00	41.27	56.00	-14.73	QP
8	1.31778	13.17	9.63	0.05	10.00	32.85	46.00	-13.15	Average
9	4.36060	19.48	9.66	0.06	10.00	39.20	56.00	-16.80	QP
10	4.36160	8.52	9.66	0.06	10.00	28.24	46.00	-17.76	Average
11	8.06243	23.46	9.70	0.07	10.00	43.23	60.00	-16.77	QP
12	8.06343	11.88	9.70	0.07	10.00	31.65	50.00	-18.35	Average

Remarks: 1. Measured = Reading + Lisn Factor +Cable Loss+Atten_Fac.
 2. The emission levels that are 20dB below the official limit are not reported.

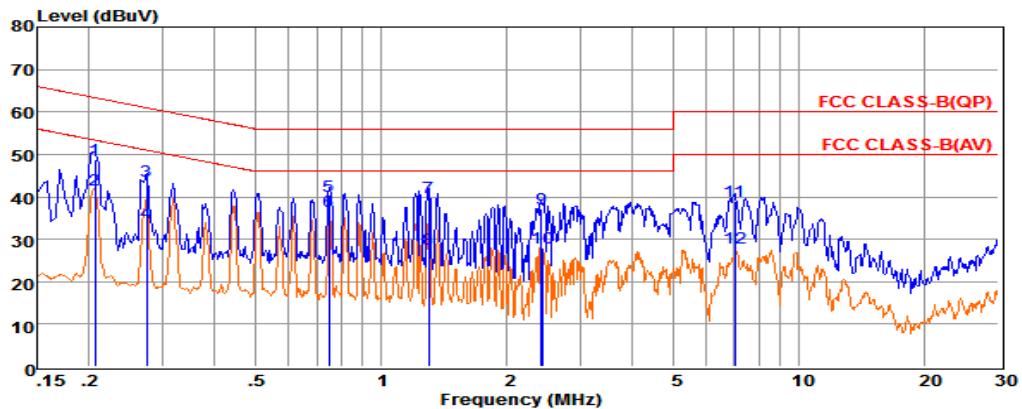

Env. Ins: 24*/56%
 Pol: LINE

	Freq	Reading	LisnFac	CabLos	Atten_Fac	Measured	Limit	Over	Remark
	MHz	dBuV	dB	dB	dB	dBuV	dBuV	dB	
1	0.20614	29.07	9.63	0.03	10.00	48.73	63.36	-14.63	QP
2	0.20624	21.87	9.63	0.03	10.00	41.53	53.36	-11.83	Average
3	0.27442	23.97	9.63	0.03	10.00	43.63	60.98	-17.35	QP
4	0.27452	14.34	9.63	0.03	10.00	34.00	50.98	-16.98	Average
5	0.75094	20.60	9.64	0.04	10.00	40.28	56.00	-15.72	QP
6	0.75104	16.93	9.64	0.04	10.00	36.61	46.00	-9.39	Average
7	1.29602	20.20	9.63	0.05	10.00	39.88	56.00	-16.12	QP
8	1.29702	8.08	9.63	0.05	10.00	27.76	46.00	-18.24	Average
9	2.42177	17.41	9.64	0.05	10.00	37.10	56.00	-18.90	QP
10	2.42277	8.24	9.64	0.05	10.00	27.93	46.00	-18.07	Average
11	7.02488	19.13	9.68	0.07	10.00	38.88	60.00	-21.12	QP
12	7.02588	8.16	9.68	0.07	10.00	27.91	50.00	-22.09	Average

Remarks: 1. Measured = Reading + Lisn Factor +Cable Loss+Atten_Fac.
 2. The emission levels that are 20dB below the official limit are not reported.

4.2. Occupied Bandwidth and Emission Mask Test

TEST APPLICABLE

- (a). Occupied Bandwidth: The EUT was connected to the audio signal generator and the spectrum analyzer via the main RF connector, and through an appropriate attenuator. The EUT was controlled to transmit its maximum power. Then the bandwidth of 99% power can be measured by the spectrum analyzer.
- (b). Emission Mask B: For transmitters that are equipped with an audio low-pass filter pursuant to §90.211(a), the power of any emission must be below the unmodulated carrier power (P) as follows:
- (1) On any frequency removed from the assigned frequency by more than 50 percent, but not more than 100 percent of the authorized bandwidth: At least 25 dB.
 - (2) On any frequency removed from the assigned frequency by more than 100 percent, but not more than 250 percent of the authorized bandwidth: At least 35 dB.
 - (3) On any frequency removed from the assigned frequency by more than 250 percent of the authorized bandwidth: At least $43 + 10 \log (P)$ dB.
- (c). Emission Mask D, 12.5 kHz channel bandwidth equipment: For transmitters designed to operate with a 12.5 kHz channel bandwidth, any emission must be attenuated below the power (P) of the highest emission contained within the authorized bandwidth as follows:
- (1) On any frequency from the centre of the authorized bandwidth f_0 to 5.625 kHz removed from f_0 : Zero dB.
 - (2) On any frequency removed from the centre of the authorized bandwidth by a displacement frequency (f_d in kHz) of more than 5.625 kHz but no more than 12.5 kHz: At least $7.27(f_d - 2.88 \text{ kHz})$ dB.
 - (3) On any frequency removed from the centre of the authorized bandwidth by a displacement frequency (f_d in kHz) of more than 12.5 kHz: At least $50 + 10 \log (P)$ dB or 70 dB, whichever is the lesser attenuation.

TEST CONFIGURATION

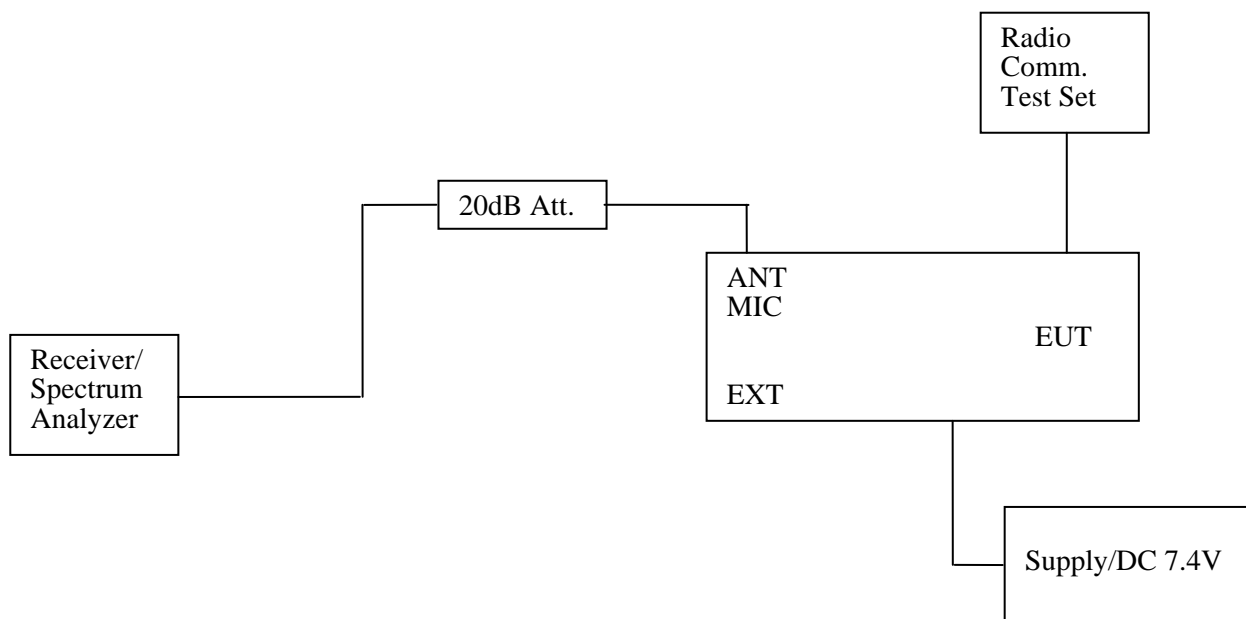

TEST PROCEDURE

- 1 The EUT was placed on a turn table which is 0.8m above ground plane.
- 2 The EUT was modulated by 2.5 KHz Sine wave audio signal; the level of the audio signal employed is 16 dB greater than that necessary to produce 50% of rated system deviation. Rated system deviation is 2.5 kHz (12.5 kHz channel spacing).
- 3 Set EUT as normal operation.
- 4 Set SPA Centre Frequency = fundamental frequency, RBW=300Hz, VBW= 3 KHz, span =50 KHz.
- 5 Set SPA Max hold. Mark peak, Set 99% Occupied Bandwidth and 26dB Occupied Bandwidth.
- 6 Set SPA Centre Frequency=fundamental frequency, set =300Hz, VBW=1 KHz, span=50 KHz for 12.5 KHz channel spacing.

TEST RESULTS

Remark: We tested Op 1 to Op 4, recorded worst case at Op 1 and Op 3.

4.2.1 Occupied Bandwidth

Modulation Type	Channel Separation	Operation Mode	Test Channel	Test Frequency (MHz)	Occupied Bandwidth (KHz)	
					99%	26dB
Analog/FM	12.5KHz	Op 1	Ch1	450.025	5.70	10.30
			Ch2	467.775	5.70	10.40
			Ch3	511.9875	5.70	10.30
Digital/4FSK	12.5KHz	Op 3	Ch4	450.025	7.50	9.80
			Ch5	467.775	7.40	9.70
			Ch6	511.9875	7.40	9.30
Limit			11.25KHz for 12.5KHz Channel Separation			
Test Results			PASS			

Plots of 99% and 26dB Bandwidth Measurement

Modulation Type	Channel Separation	Operation Mode	Test Channel	Test Frequency (MHz)	Occupied Bandwidth (KHz)		Limit (KHz)	Results
					99%	26dB		
FM	12.5 KHz	Op 1	Ch1	450.025	5.70	10.30	11.25	PASS

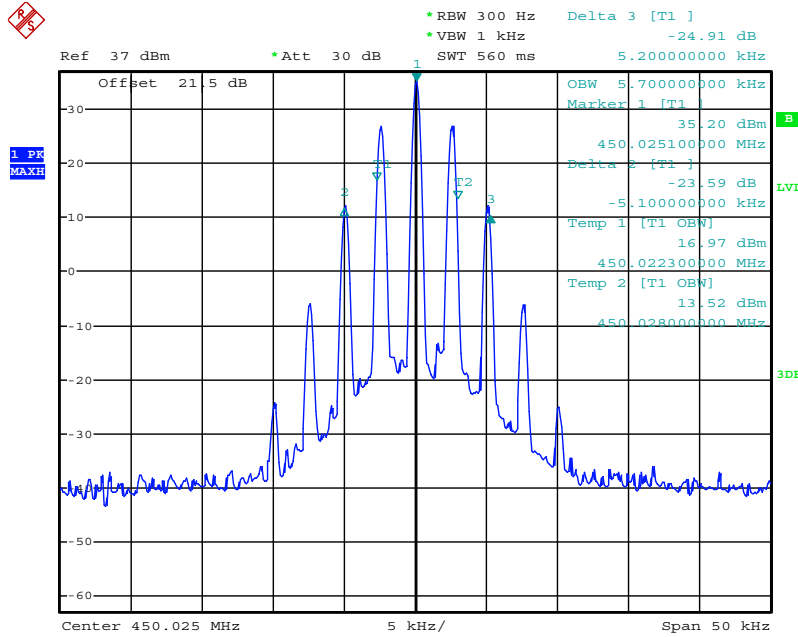

Date: 17.MAY.2016 22:00:18

Modulation Type	Channel Separation	Operation Mode	Test Channel	Test Frequency (MHz)	Occupied Bandwidth (KHz)		Limit (KHz)	Results
					99%	26dB		
FM	12.5 KHz	Op 1	Ch2	467.775	5.70	10.40	11.25	PASS

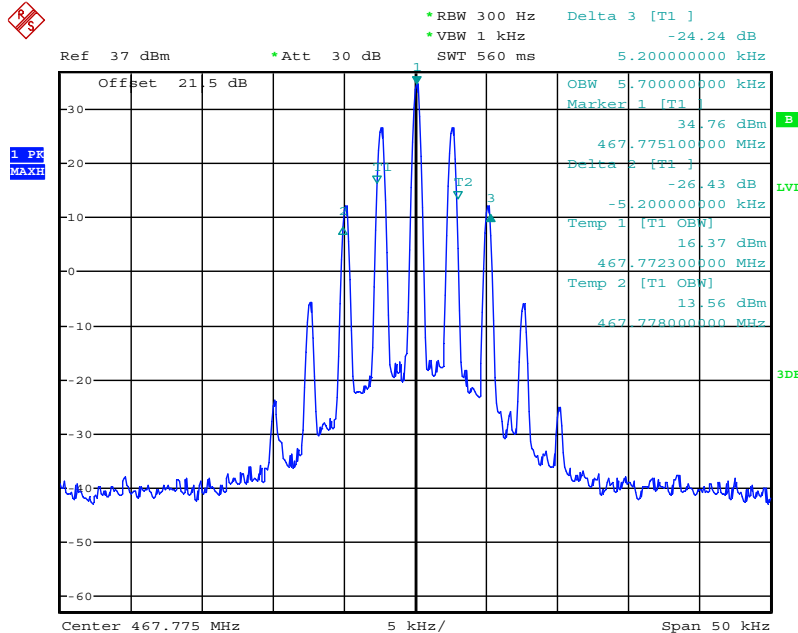

Date: 17.MAY.2016 22:01:22

Modulation Type	Channel Separation	Operation Mode	Test Channel	Test Frequency (MHz)	Occupied Bandwidth (KHz)		Limit (KHz)	Results
					99%	26dB		
FM	12.5 KHz	Op 1	Ch3	511.9875	5.70	10.30	11.25	PASS

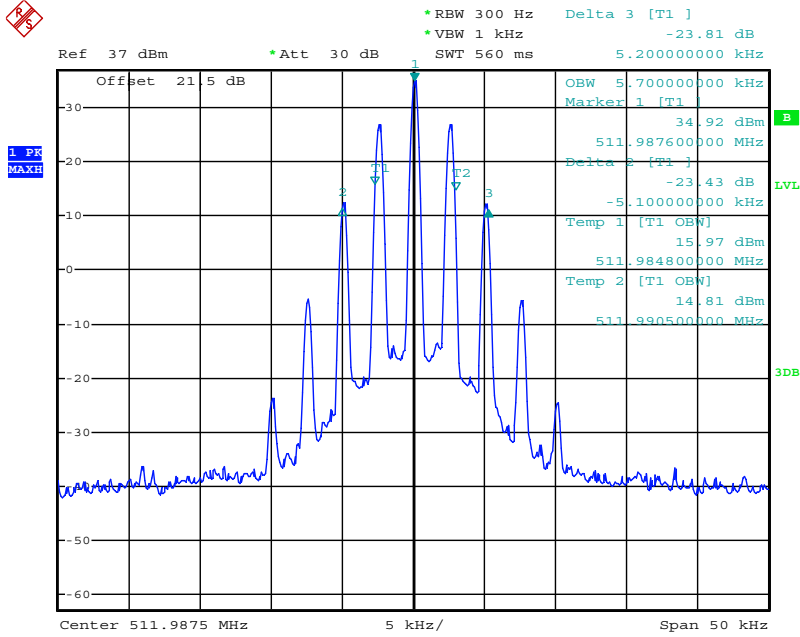

Date: 17.MAY.2016 22:02:36

Modulation Type	Channel Separation	Operation Mode	Test Channel	Test Frequency (MHz)	Occupied Bandwidth (KHz)		Limit (KHz)	Results
					99%	26dB		
4FSK	12.5 KHz	Op 3	Ch4	450.025	7.50	9.80	11.25	PASS

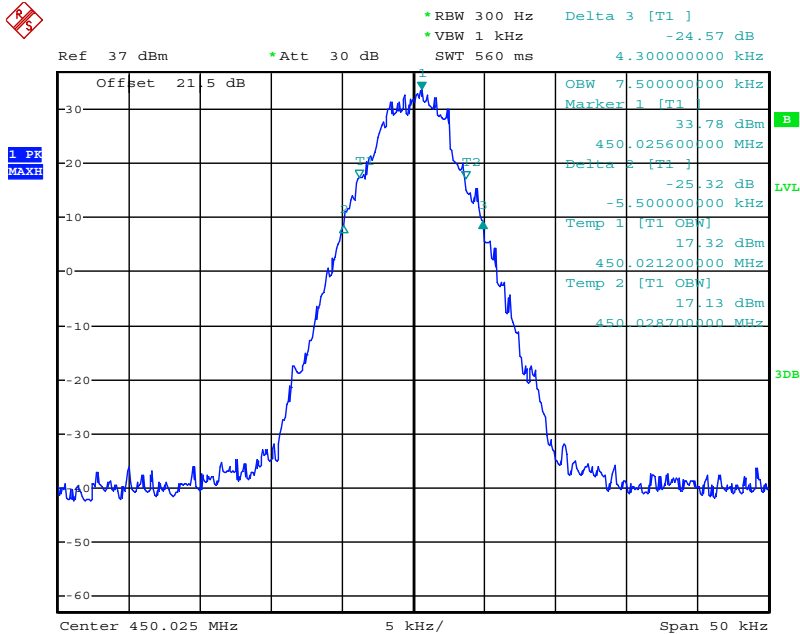

Date: 17.MAY.2016 22:10:20

Modulation Type	Channel Separation	Operation Mode	Test Channel	Test Frequency (MHz)	Occupied Bandwidth (KHz)		Limit (KHz)	Results
					99%	26dB		
4FSK	12.5 KHz	Op 3	Ch5	467.775	7.40	9.70	11.25	PASS

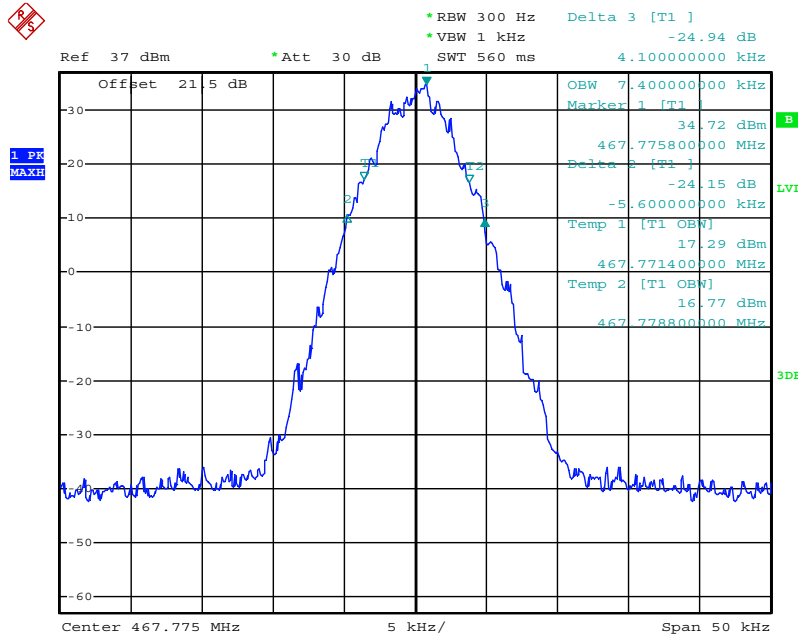

Date: 17.MAY.2016 22:11:34

Modulation Type	Channel Separation	Operation Mode	Test Channel	Test Frequency (MHz)	Occupied Bandwidth (KHz)		Limit (KHz)	Results
					99%	26dB		
4FSK	12.5 KHz	Op 3	Ch6	511.9875	7.40	9.30	11.25	PASS

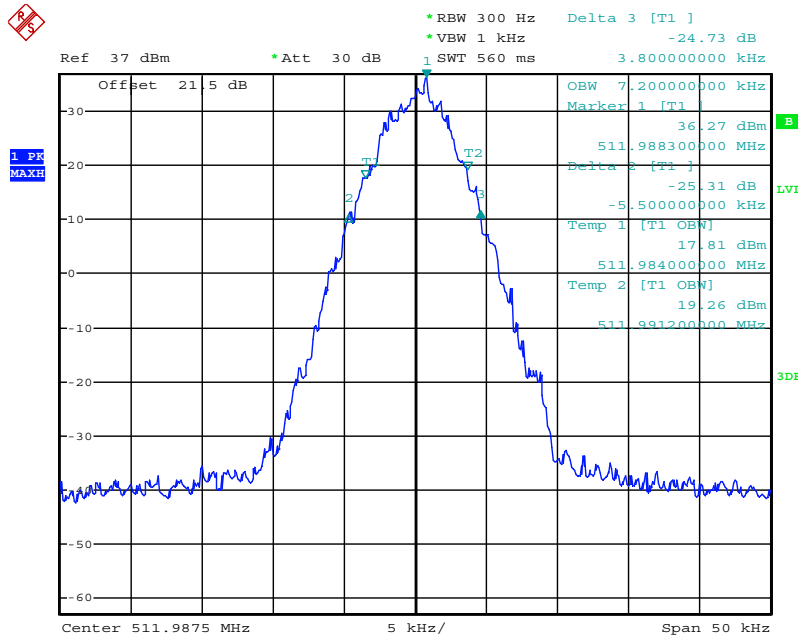

Date: 17.MAY.2016 22:13:08

4.2.2 Emission Mask

Modulation Type	Channel Separation	Operation Mode	Test Channel	Test Frequency (MHz)	Applicable Mask	RBW (Hz)
Analog/FM	12.5 KHz	Op 1	Ch1	450.025	D	300
			Ch2	467.775	D	300
			Ch3	511.9875	D	300
Digital/4FSK	12.5 KHz	Op 3	Ch4	450.025	D	300
			Ch5	467.775	D	300
			Ch6	511.9875	D	300
Test Results			PASS			

Plots of Emission Mask Measurement

Referred as the attached plot hereinafter

Note:

The Black curve represents unmodulated signal.

The Blue curve represents modulated signal.

Modulation Type	Channel Separation	Operation Mode	Test Channel	Test Frequency (MHz)	Applicable Mask	RBW (Hz)	Audio Freq. (KHz)	Results
FM	12.5KHz	Op 1	Ch1	450.025	D	300	2.5	PASS

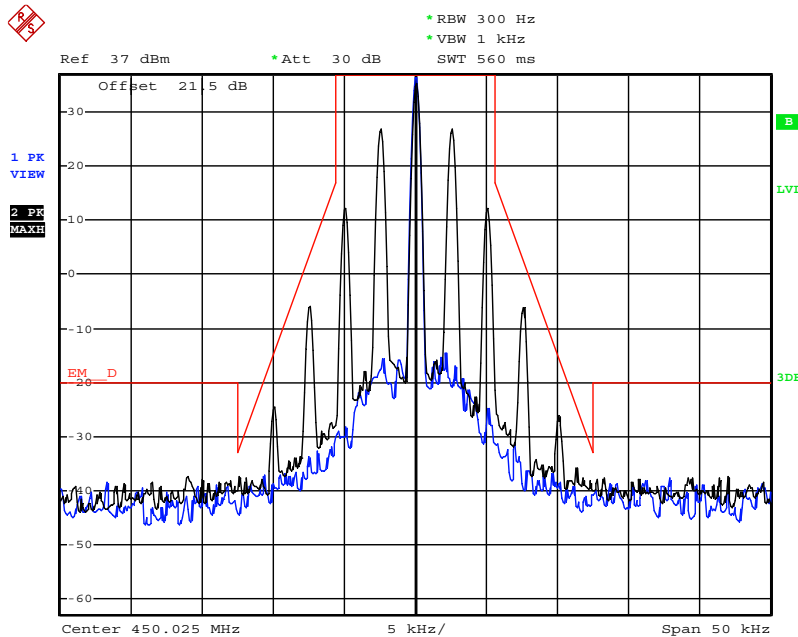

Date: 17.MAY.2016 22:22:35

Modulation Type	Channel Separation	Operation Mode	Test Channel	Test Frequency (MHz)	Applicable Mask	RBW (Hz)	Audio Freq. (KHz)	Results
FM	12.5KHz	Op 1	Ch2	467.775	D	300	2.5	PASS

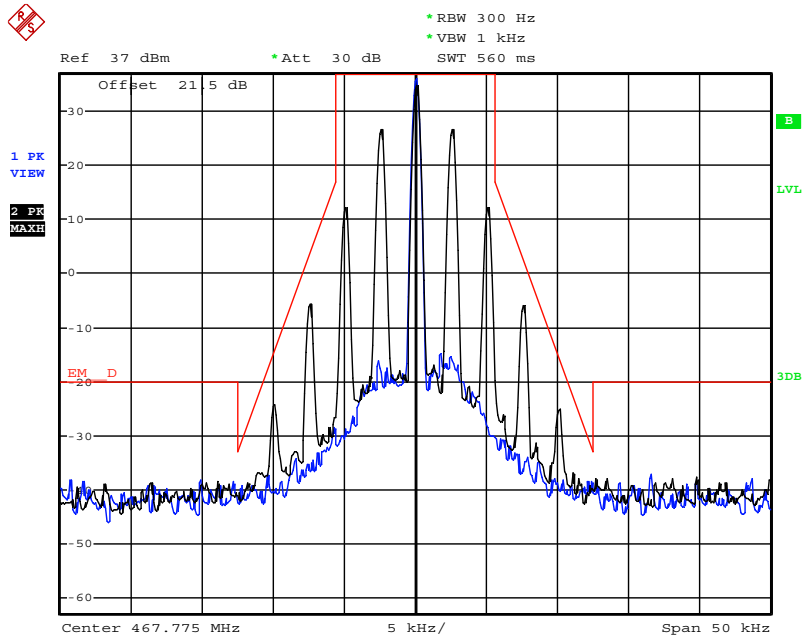

Date: 17.MAY.2016 22:23:32

Modulation Type	Channel Separation	Operation Mode	Test Channel	Test Frequency (MHz)	Applicable Mask	RBW (Hz)	Audio Freq. (KHz)	Results
FM	12.5KHz	Op 1	Ch3	511.9875	D	300	2.5	PASS

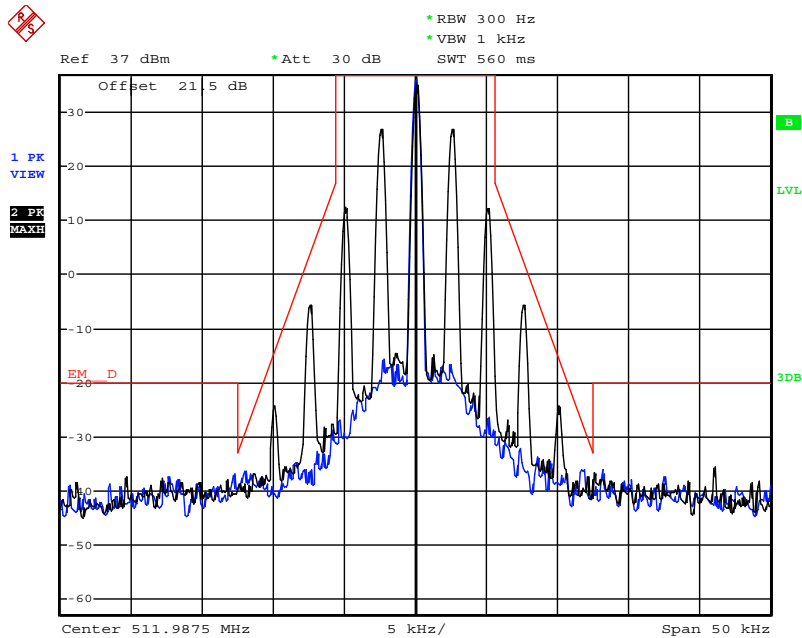

Date: 17.MAY.2016 22:24:41

Modulation Type	Channel Separation	Operation Mode	Test Channel	Test Frequency (MHz)	Applicable Mask	RBW (Hz)	Audio Freq. (KHz)	Results
4FSK	12.5KHz	Op 3	Ch4	450.025	D	300	/	PASS

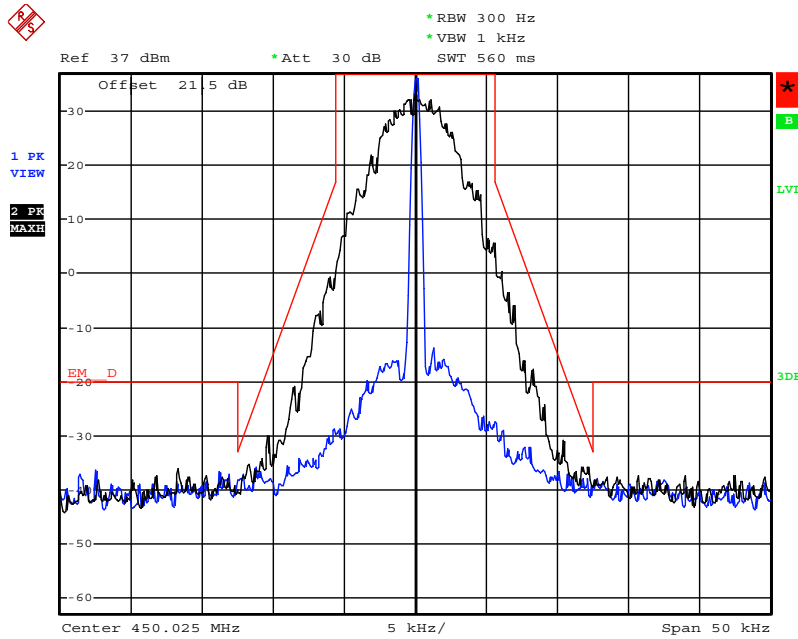

Date: 17.MAY.2016 22:20:07

Modulation Type	Channel Separation	Operation Mode	Test Channel	Test Frequency (MHz)	Applicable Mask	RBW (Hz)	Audio Freq. (KHz)	Results
4FSK	12.5KHz	Op 3	Ch5	467.775	D	300	/	PASS

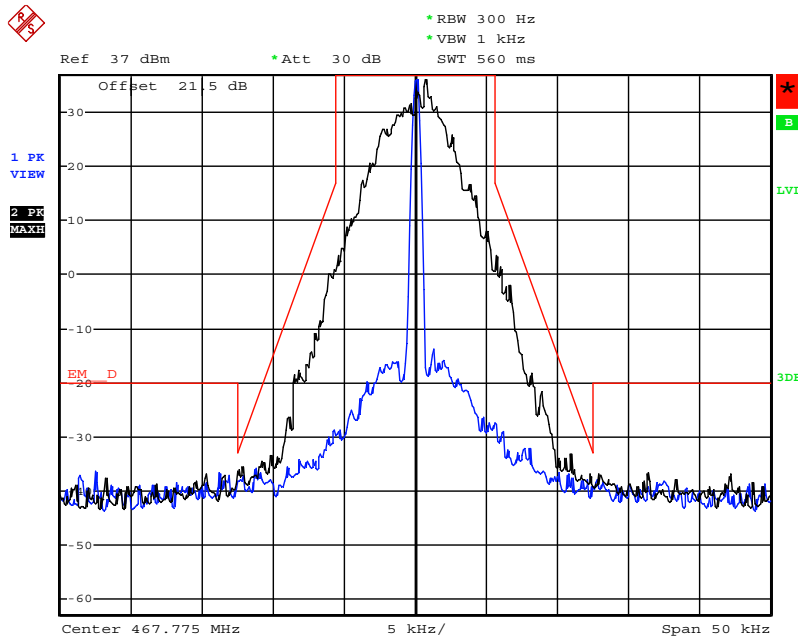

Date: 17.MAY.2016 22:19:12

Modulation Type	Channel Separation	Operation Mode	Test Channel	Test Frequency (MHz)	Applicable Mask	RBW (Hz)	Audio Freq. (KHz)	Results
4FSK	12.5KHz	Op 3	Ch6	511.9875	D	300	/	PASS

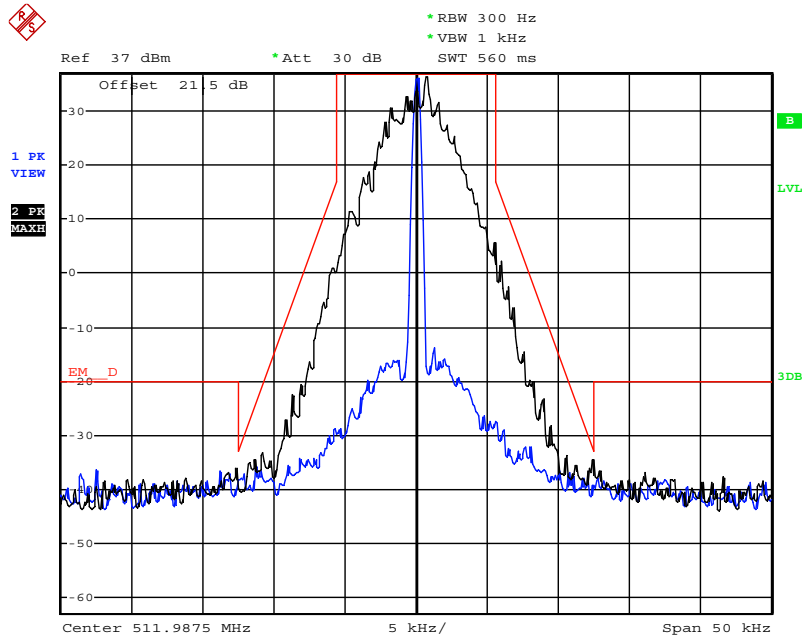

Date: 17.MAY.2016 22:18:19

4.3. Transmitter Radiated Spurious Emission

TEST APPLICABLE

According to the TIA/EIA 603 test method, and according to Section 90.210, the power of each unwanted emission shall be less than Transmitted Power as specified below for transmitters designed to operate with 12.5 KHz channel bandwidth:

- 1 On any frequency removed from the centre of the authorized bandwidth f_0 to 5.625 KHz removed from f_0 : Zero dB
- 2 On any frequency removed from the centre of the authorized bandwidth by a displacement frequency (f_d in KHz) f_0 of more than 5.625 KHz but no more than 12.5 KHz: At least 7.27dB
- 3 On any frequency removed from the centre of the authorized bandwidth by a displacement frequency (f_d in KHz) f_0 of more than 12.5 KHz: At least $50+10 \log (P)$ dB or 70 dB, which ever is lesser attenuation.

For transmitters designed to transmit with 25 KHz channel separation and equipped with an audio low-pass filter, the power of any emission must be attenuated below the unmodulated carrier power (P) as following:

- 1 On any frequency removed from the assigned frequency by more than 50 percent, but no more than 100 percent of the authorized bandwidth: At least 25 dB.
- 2 On any frequency removed from the assigned frequency by more than 100 percent, but no more than 250 percent of the authorized bandwidth: At least 35 dB.
- 3 On any frequency removed from the assigned frequency by more than 250 percent of the authorized bandwidth: At least $43+10\text{Log} (P)$ dB.

TEST CONFIGURATION

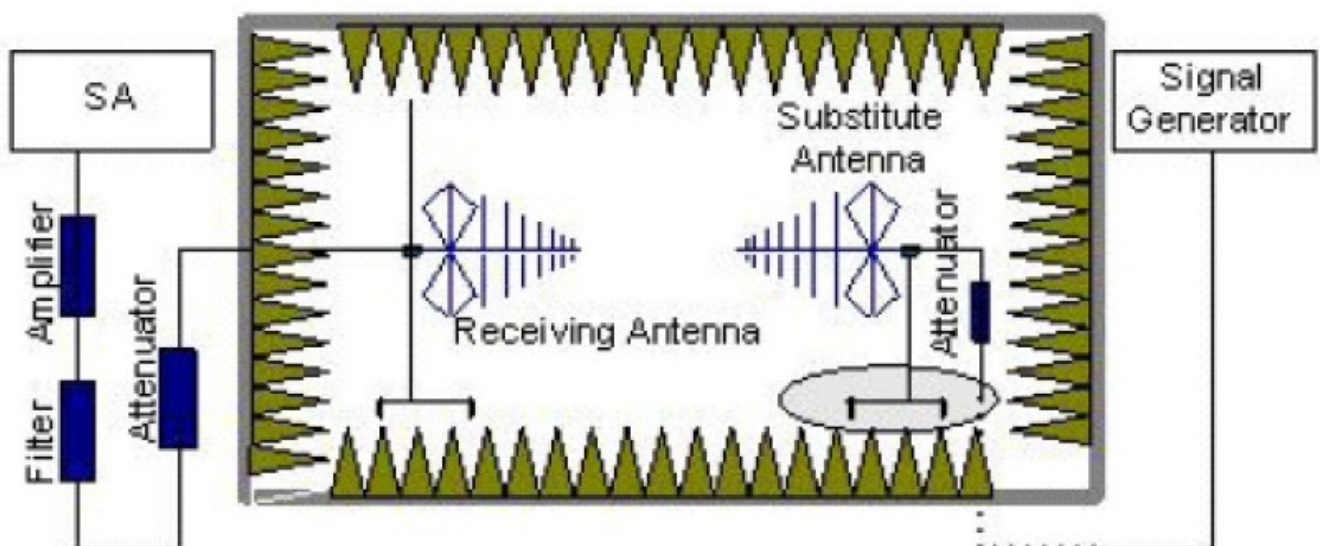

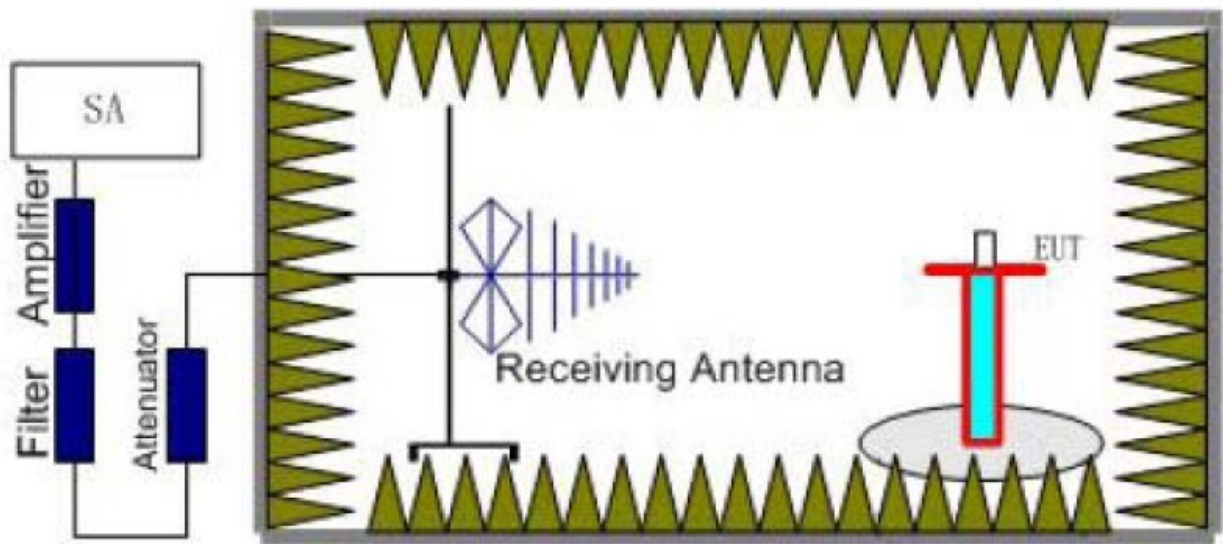

TEST PROCEDURE

1. EUT was placed on a 1.50 meter high non-conductive stand at a 3 meter test distance from the receive antenna. A receiving antenna was placed on the antenna mast 3 meters from the EUT for emission measurements. The height of receiving antenna is 1.50 m. Detected emissions were maximized at each frequency by rotating the EUT through 360° and adjusting the receiving antenna polarization. The radiated emission measurements of all transmit frequencies in six channels were measured with peak detector.
2. A log-periodic antenna or double-ridged waveguide horn antenna shall be substituted in place of the EUT. The log-periodic antenna will be driven by a signal generator and the level will be adjusted till the same power value on the spectrum analyzer or receiver. The level of the spurious emissions can be calculated through the level of the signal generator, cable loss, the gain of the substitution antenna and the reading of the spectrum analyzer or receiver.
3. The EUT is then put into continuously transmitting mode at its maximum power level during the test. Set Test Receiver or Spectrum RBW=1MHz, VBW=3MHz for above 1GHz and RBW=100 KHz, VBW=300 KHz for 30MHz to 1GHz, and the maximum value of the receiver should be recorded as (P_r).
4. The EUT shall be replaced by a substitution antenna. In the chamber, a substitution antenna for the frequency band of interest is placed at the reference point of the chamber. An RF Signal source for the frequency band of interest is connected to the substitution antenna with a cable that has been constructed to not interfere with the radiation pattern of the antenna. A power (P_{Mea}) is applied to the input of the substitution antenna, and adjust the level of the signal generator output until the value of the receiver reach the previously recorded (P_r). The power of signal source (P_{Mea}) is recorded. The test should be performed by rotating the test item and adjusting the receiving antenna polarization.
5. An amplifier should be connected to the Signal Source output port. And the cable should be connect between the Amplifier and the Substitution Antenna. The cable loss (P_{cl}), the Substitution Antenna Gain (G_a) and the Amplifier Gain (P_{Ag}) should be recorded after test. The measurement results are obtained as described below:

$$\text{Power (EIRP)} = P_{Mea} - P_{Ag} - P_{cl} - G_a$$

Amplifier for substitution test;

The measurement results are amending as described below:

$$\text{Power (EIRP)} = P_{Mea} - P_{cl} - G_a$$

6. This value is EIRP since the measurement is calibrated using an antenna of known gain (2.15 dBi) and known input power.
7. ERP can be calculated from EIRP by subtracting the gain of the dipole, $ERP = EIRP - 2.15 \text{ dBi}$.

LIMIT

Modulation Type: FM

FCC Part 22.359, 74.462, 80.211 and 90.210 and RSS Gen, RSS 119 Issue 12:

For 12.5 kHz bandwidth:

On any frequency removed from the center of the authorized bandwidth by a displacement frequency (f_d in kHz) of more than 12.5 kHz at least:

High: $50 + 10 \log(P_{\text{watts}}) = 50 + 10 \log(4.0) = 56.02 \text{ dB}$

Low: $50 + 10 \log(P_{\text{watts}}) = 50 + 10 \log(1.0) = 50.00 \text{ dB}$

Note: In general, the worst case attenuation requirement shown above was applied.

Calculation: Limit (dBm) = $EL - 50 - 10 \log_{10}(TP)$

Notes: EL is the emission level of the Output Power expressed in dBm,

In this application, the EL is 36.02 dBm for Rated High power level and 30.00 dBm for Rated Lower power level;

High: Limit (dBm) = $36.02 - 50 - 10 \log_{10}(4.0) = -20 \text{ dBm}$

Low: Limit (dBm) = $30.00 - 50 - 10 \log_{10}(1.0) = -20 \text{ dBm}$

Modulation Type: 4FSK

FCC Part 22.359, 74.462, 80.211 and 90.210 and RSS Gen, RSS 119 Issue 12 (12.5 kHz Bandwidth only):

On any frequency removed from the center of the authorized bandwidth by a displacement frequency (f_d in kHz) of more than 12.5 kHz at least:

High: $50 + 10 \log(P_{\text{watts}}) = 50 + 10 \log(4.0) = 56.02 \text{ dB}$

Low: $50 + 10 \log(P_{\text{watts}}) = 50 + 10 \log(1.0) = 50.00 \text{ dB}$

Note: In general, the worst case attenuation requirement shown above was applied.

Calculation: Limit (dBm) = $EL - 50 - 10 \log_{10}(TP)$

Notes: EL is the emission level of the Output Power expressed in dBm,

In this application, the EL is 36.02 dBm for Rated High power level and 30.00 dBm for Rated Lower power level;

High: Limit (dBm) = $36.02 - 50 - 10 \log_{10}(4.0) = -20 \text{ dBm}$

Low: Limit (dBm) = $30.00 - 50 - 10 \log_{10}(1.0) = -20 \text{ dBm}$

Note:

1. In general, the worst case attenuation requirement shown above was applied.
2. The measurement frequency range from 30 MHz to 6 GHz.
3. *** means that the emission level is too low to be measured or at least 20 dB down than the limit.
4. Radiated spurious tested ERP for below 1GHz and EIRP for above 1GHz.

TEST RESULTS

Remark: We tested Op 1 to Op 4, recorded worst case at *Op 1 and Op 3*.

Modulation Type: FM							
Operation Mode: Op 1				Channel Separation:12.5KHz			
Test Channel: Ch1				Test Frequency:450.025MHz			
Frequency (MHz)	P _{Mea} (dBm)	Path Loss	Antenna Gain	Correction (dB)	Peak ERP(dBm)	Limit (dBm)	Polarization
900.050	-52.11	0.87	6.42	2.15	-48.71	-20.00	H
1350.075	-48.02	1.02	7.35	2.15	-41.69	-20.00	H
2250.125	-58.73	1.10	8.26	2.15	-51.57	-20.00	H
...	H
900.050	-49.33	0.87	6.42	2.15	-45.93	-20.00	V
1350.075	-45.98	1.02	7.35	2.15	-39.65	-20.00	V
2250.125	-56.69	1.10	8.26	2.15	-49.53	-20.00	V
...	V

Modulation Type: FM							
Operation Mode: Op 1				Channel Separation:12.5KHz			
Test Channel: Ch2				Test Frequency: 467.775MHz			
Frequency (MHz)	P _{Mea} (dBm)	Path Loss	Antenna Gain	Correction (dB)	Peak ERP(dBm)	Limit (dBm)	Polarization
935.550	-51.54	0.92	6.80	2.15	-47.81	-20.00	H
1403.325	-41.73	1.06	7.89	2.15	-34.90	-20.00	H
2338.875	-59.13	1.12	8.12	2.15	-52.13	-20.00	H
...	H
935.550	-50.78	0.92	6.80	2.15	-47.05	-20.00	V
1403.325	-44.36	1.06	7.89	2.15	-37.53	-20.00	V
2338.875	-58.62	1.12	8.12	2.15	-51.62	-20.00	V
...	V

Modulation Type: FM							
Operation Mode: Op 1				Channel Separation:12.5KHz			
Test Channel: Ch3				Test Frequency: 511.9875MHz			
Frequency (MHz)	P _{Mea} (dBm)	Path Loss	Antenna Gain	Correction (dB)	Peak ERP(dBm)	Limit (dBm)	Polarization
1023.9750	-51.74	0.95	6.80	2.15	-48.04	-49.52	H
1535.9625	-43.70	1.10	7.91	2.15	-36.89	-39.68	H
2559.9375	-61.41	1.21	8.25	2.15	-54.37	-54.58	H
...	H
1023.9750	-51.69	0.95	6.80	2.15	-47.99	-20.00	V
1535.9625	-41.81	1.10	7.91	2.15	-35.00	-20.00	V
2559.9375	-58.42	1.21	8.25	2.15	-51.38	-20.00	V
...	V

Modulation Type: 4FSK							
Operation Mode: Op 3				Channel Separation:12.5KHz			
Test Channel: Ch4				Test Frequency:450.025MHz			
Frequency (MHz)	P _{Mea} (dBm)	Path Loss	Antenna Gain	Correction (dB)	Peak ERP(dBm)	Limit (dBm)	Polarization
900.050	-49.97	0.87	6.42	2.15	-46.57	-20.00	H
1350.075	-44.09	1.02	7.35	2.15	-37.76	-20.00	H
2250.125	-60.02	1.10	8.26	2.15	-52.86	-20.00	H
...	H
900.050	-52.07	0.87	6.42	2.15	-48.67	-20.00	V
1350.075	-43.16	1.02	7.35	2.15	-36.83	-20.00	V
2250.125	-61.14	1.10	8.26	2.15	-53.98	-20.00	V
900.050	V

Modulation Type: 4FSK							
Operation Mode: Op 3				Channel Separation:12.5KHz			
Test Channel: Ch5				Test Frequency: 467.775MHz			
Frequency (MHz)	P _{Mea} (dBm)	Path Loss	Antenna Gain	Correction (dB)	Peak ERP(dBm)	Limit (dBm)	Polarization
935.550	-51.69	0.92	6.80	2.15	-47.96	-20.00	H
1403.325	-40.28	1.06	7.89	2.15	-33.45	-20.00	H
2338.875	-56.89	1.12	8.12	2.15	-49.89	-20.00	H
...	H
935.550	-52.94	0.92	6.80	2.15	-49.21	-20.00	V
1403.325	-40.23	1.06	7.89	2.15	-33.40	-20.00	V
2338.875	-59.80	1.12	8.12	2.15	-52.80	-20.00	V
...	V

Modulation Type: 4FSK							
Operation Mode: Op 3				Channel Separation:12.5KHz			
Test Channel: Ch6				Test Frequency: 511.9875MHz			
Frequency (MHz)	P _{Mea} (dBm)	Path Loss	Antenna Gain	Correction (dB)	Peak ERP(dBm)	Limit (dBm)	Polarization
1023.9750	-50.05	0.95	6.80	2.15	-46.35	-20.00	H
1535.9625	-44.11	1.10	7.91	2.15	-37.30	-20.00	H
2559.9375	-55.28	1.21	8.25	2.15	-48.24	-20.00	H
...	H
1023.9750	-54.98	0.95	6.80	2.15	-51.28	-20.00	V
1535.9625	-46.34	1.10	7.91	2.15	-39.53	-20.00	V
2559.9375	-65.06	1.21	8.25	2.15	-58.02	-20.00	V
...	V

4.4. Spurious Emission on Antenna Port

TEST APPLICABLE

The same as Section 4.3

TEST PROCEDURE

The RF output of the EUT was connected to a spectrum analyzer through appropriate attenuation. The resolution bandwidth of the spectrum analyzer was set to 100 kHz. Sufficient scans were taken to show any out of band emission up to 10th. Harmonic for the lower and the highest frequency range. Set RBW=1KHz/VBW=3KHz in the frequency band 9KHz to 150KHz, RBW=10KHz/VBW=30 KHz in the frequency band 150KHz to 30 MHz, RBW=100 kHz/VBW=300 kHz in the frequency band 30MHz to 1GHz, and RBW=1MHz/VBW=3MHz from the 1GHz to 10th Harmonic.

The audio input was set to 0 to get the unmodulated carrier, the resulting picture is print out for each channel separation.

TEST CONFIGURATION

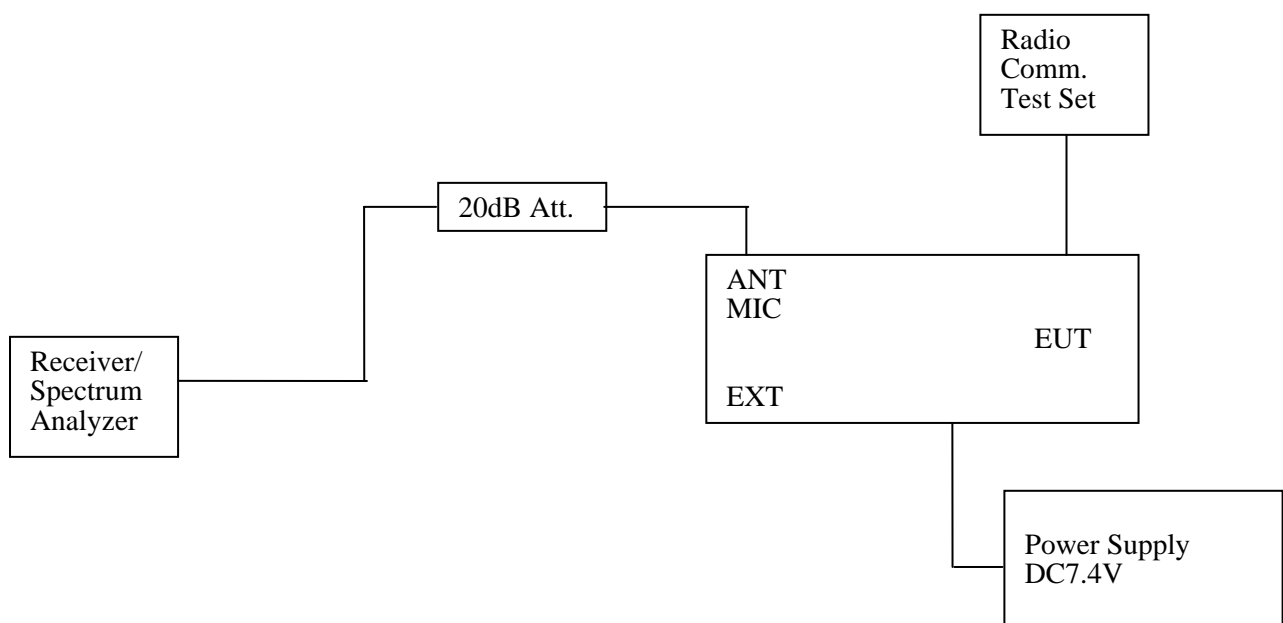

LIMIT

Modulation Type: FM

FCC Part 22.359, 74.462, 80.211 and 90.210 and RSS Gen, RSS 119 Issue 12:

For 12.5 kHz bandwidth:

On any frequency removed from the center of the authorized bandwidth by a displacement frequency (f_d in kHz) of more than 12.5 kHz at least:

High: $50 + 10 \log(P_{\text{watts}}) = 50 + 10 \log(4.0) = 56.02 \text{ dB}$

Low: $50 + 10 \log(P_{\text{watts}}) = 50 + 10 \log(1.0) = 50.00 \text{ dB}$

Note: In general, the worst case attenuation requirement shown above was applied.

Calculation: Limit (dBm) = EL-50-10log10 (TP)

Notes: EL is the emission level of the Output Power expressed in dBm,

In this application, the EL is 36.02 dBm for Rated High power level and 30.00 dBm for Rated Lower power level;

High: Limit (dBm) = $36.02 - 50 - 10 \log_{10}(4.0) = -20$ dBm

Low: Limit (dBm) = $30.00 - 50 - 10 \log_{10}(1.0) = -20$ dBm

Modulation Type: 4FSK

FCC Part 22.359, 74.462, 80.211 and 90.210 and RSS Gen, RSS 119 Issue 12 (12.5 kHz Bandwidth only):

On any frequency removed from the center of the authorized bandwidth by a displacement frequency (f_d in kHz) of more than 12.5 kHz at least:

High: $50 + 10 \log(P_{\text{watts}}) = 50 + 10 \log(4.0) = 56.02$ dB

Low: $50 + 10 \log(P_{\text{watts}}) = 50 + 10 \log(1.0) = 50.00$ dB

Note: In general, the worst case attenuation requirement shown above was applied.

Calculation: Limit (dBm) = $EL - 50 - 10 \log_{10}(TP)$

Notes: EL is the emission level of the Output Power expressed in dBm,

In this application, the EL is 36.02 dBm for Rated High power level and 30.00 dBm for Rated Lower power level;

High: Limit (dBm) = $36.02 - 50 - 10 \log_{10}(4.0) = -20$ dBm

Low: Limit (dBm) = $30.00 - 50 - 10 \log_{10}(1.0) = -20$ dBm

Note:

1. In general, the worst case attenuation requirement shown above was applied.

2. The measurement frequency range from 9 KHz to 6GHz while only recorded from 9 KHz to 5GHz as test values from 5GHz to 6GHz to low.

TEST RESULTS

Operation Mode	Test Channel	Test Frequency (MHz)	Maximum Conducted Spurious Emissions Below 1GHz		Maximum Conducted Spurious Emissions Above 1GHz	
			Frequency (MHz)	Data (dBm)	Frequency (MHz)	Data (dBm)
Op 1	Ch1	450.025	901.06	-20.89	3368.00	-28.41
	Ch2	467.775	935.98	-21.18	3440.00	-28.76
	Ch3	511.9875	963.14	-31.18	1024.00	-21.43
Op 3	Ch4	450.025	901.06	-20.89	4480.00	-28.56
	Ch5	467.775	935.98	-21.49	3376.00	-28.96
	Ch6	511.9875	774.96	-31.04	1024.00	-21.10
Limit			-20dBm for 12.5KHz Channel Separation			
Test Results			PASS			

Plots of Spurious Emission on Antenna Port Measurement

Operation Mode	Test Channel	Test Frequency (MHz)	Maximum Conducted Spurious Emissions Below 1GHz		Maximum Conducted Spurious Emissions Above 1GHz		Limit (dBm)
			Frequency (MHz)	Data (dBm)	Frequency (MHz)	Data (dBm)	
Op 1	Ch1	450.025	901.06	-20.89	3368.00	-28.41	-20.00

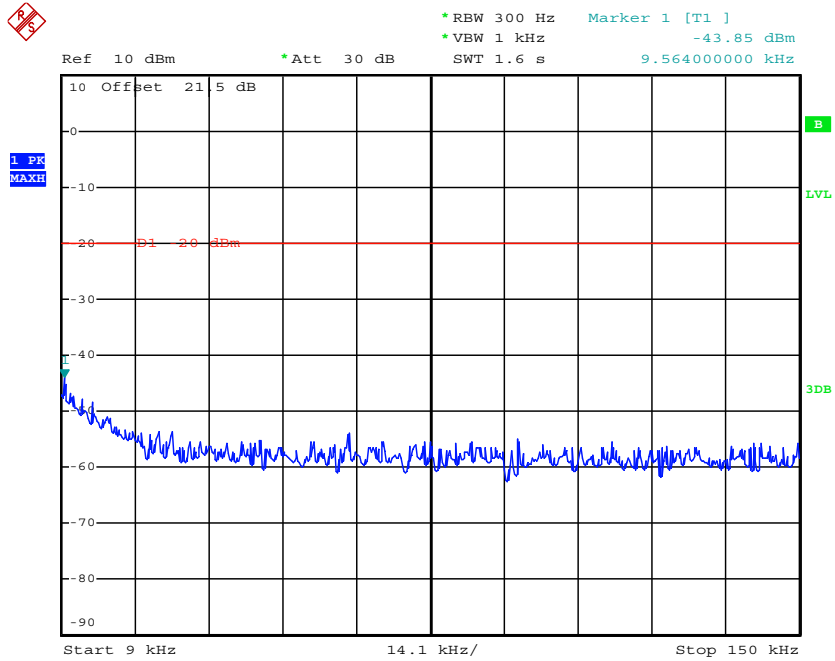

Date: 17.MAY.2016 22:32:29

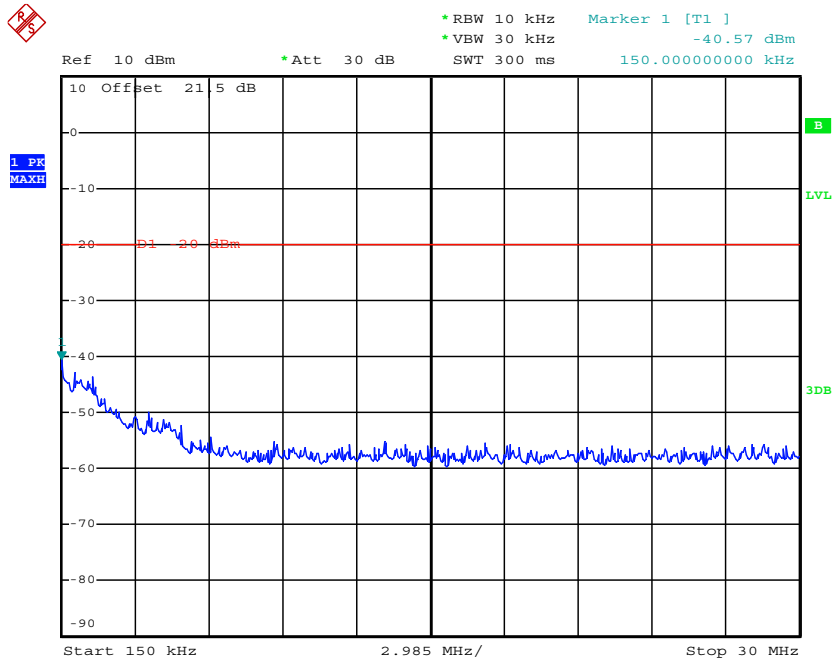

Date: 17.MAY.2016 22:36:37



Ref 37 dBm *Att 30 dB *RBW 100 kHz Marker 1 [T1] -20.89 dBm
*VBW 300 kHz SWT 100 ms 901.06000000 MHz

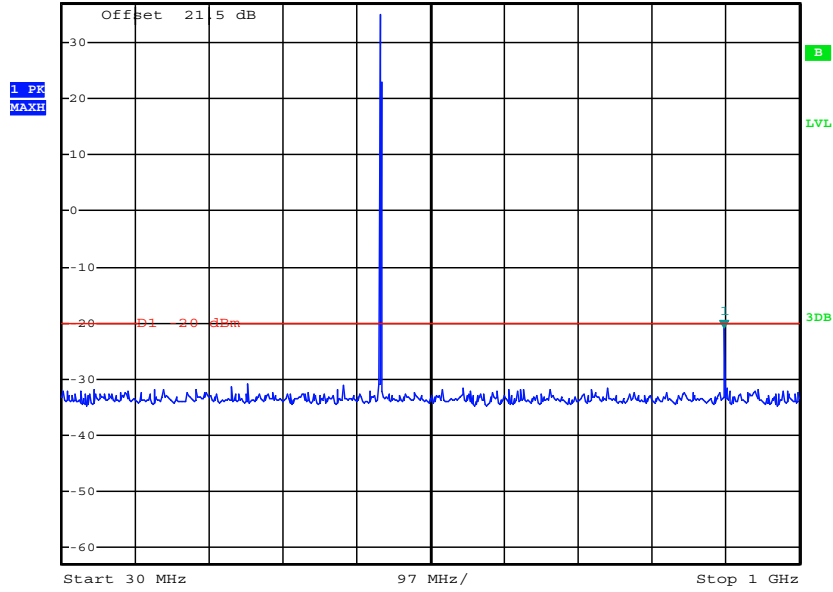

Date: 17.MAY.2016 22:48:39



Ref 37 dBm *Att 30 dB *RBW 1 MHz Marker 1 [T1] -28.41 dBm
*VBW 3 MHz SWT 50 ms 3.36800000 GHz

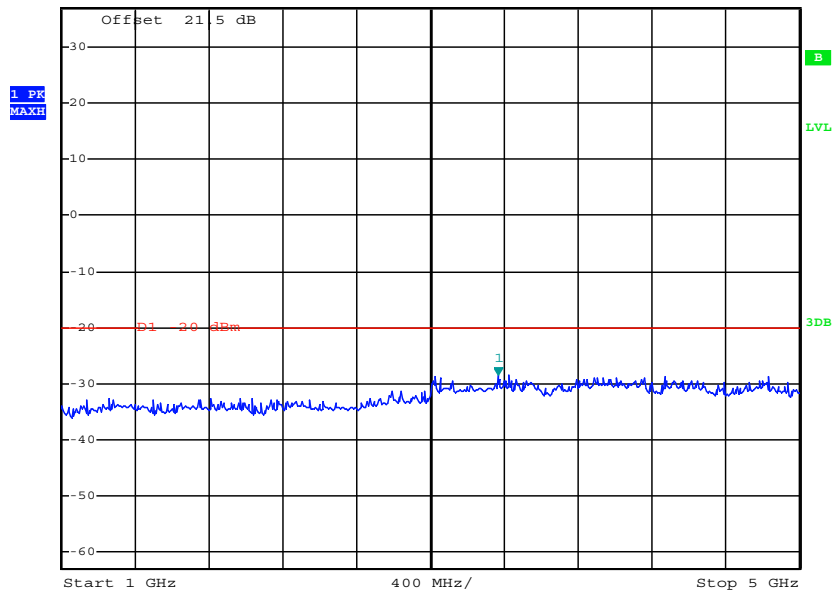

Date: 17.MAY.2016 22:59:38

Operation Mode	Test Channel	Test Frequency (MHz)	Maximum Conducted Spurious Emissions Below 1GHz		Maximum Conducted Spurious Emissions Above 1GHz		Limit (dBm)
			Frequency (MHz)	Data (dBm)	Frequency (MHz)	Data (dBm)	
Op 1	Ch2	467.775	935.98	-21.18	3440.00	-28.76	-20.00

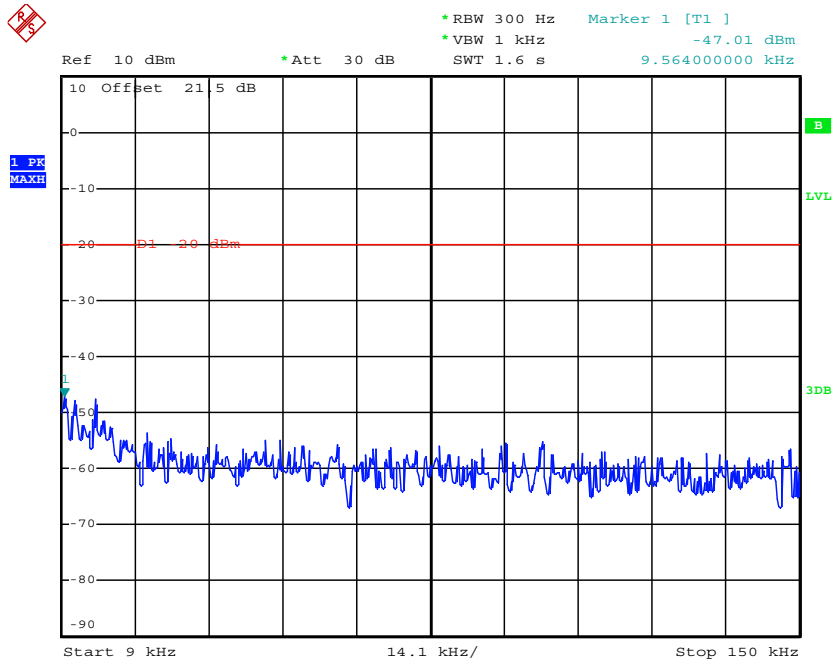

Date: 17.MAY.2016 22:32:39

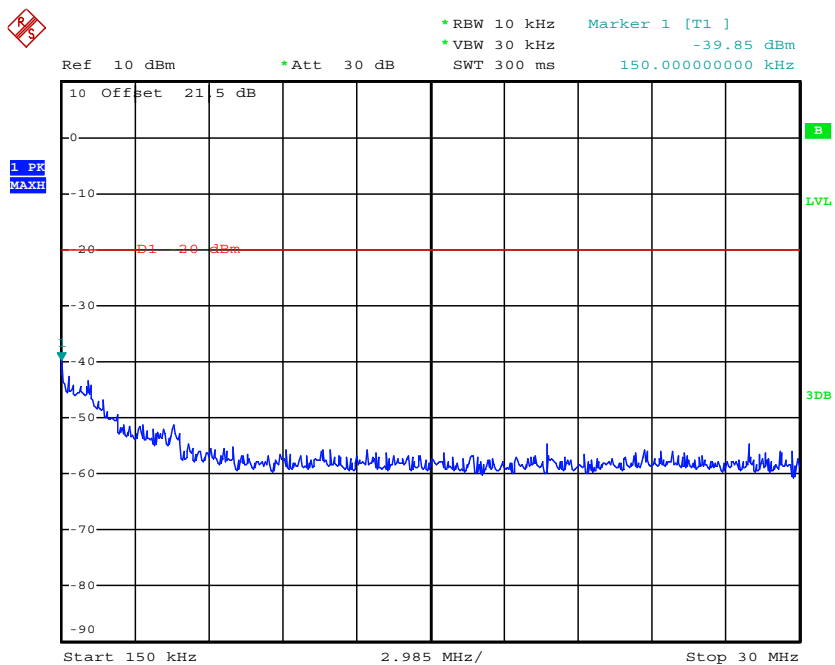

Date: 17.MAY.2016 22:36:22

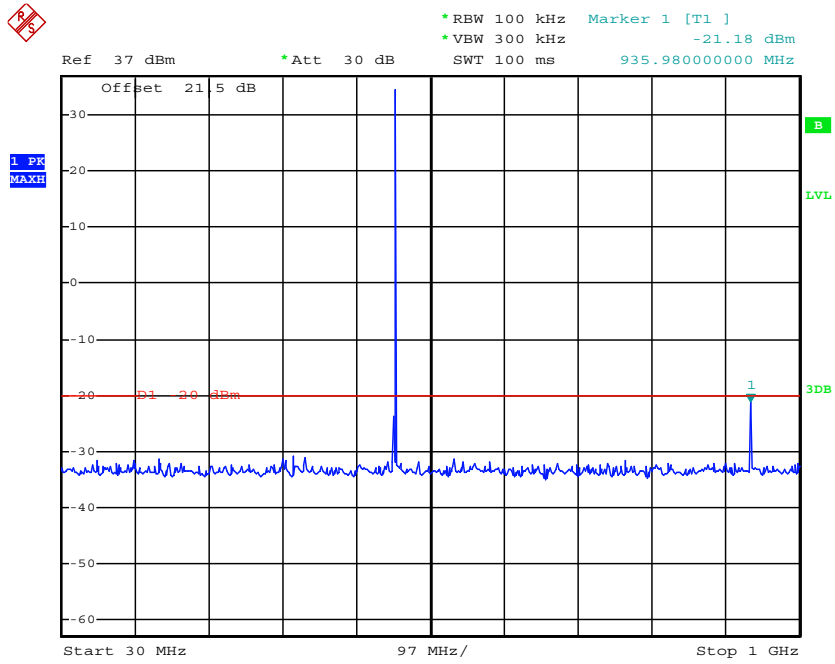

Date: 17.MAY.2016 22:49:30

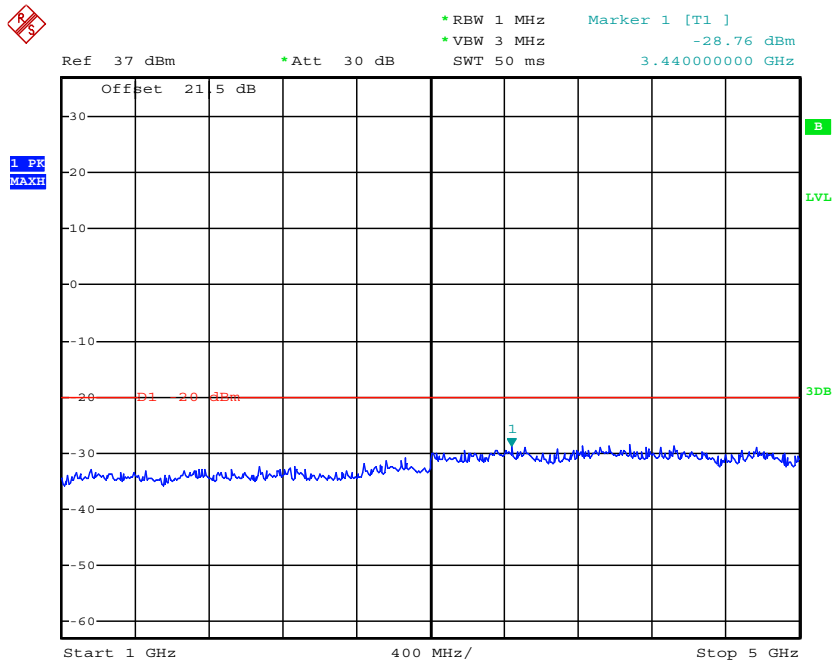

Date: 17.MAY.2016 22:59:55

Operation Mode	Test Channel	Test Frequency (MHz)	Maximum Conducted Spurious Emissions Below 1GHz		Maximum Conducted Spurious Emissions Above 1GHz		Limit (dBm)
			Frequency (MHz)	Data (dBm)	Frequency (MHz)	Data (dBm)	
Op 1	Ch3	511.9875	963.14	-31.18	1024.00	-21.43	-20.00

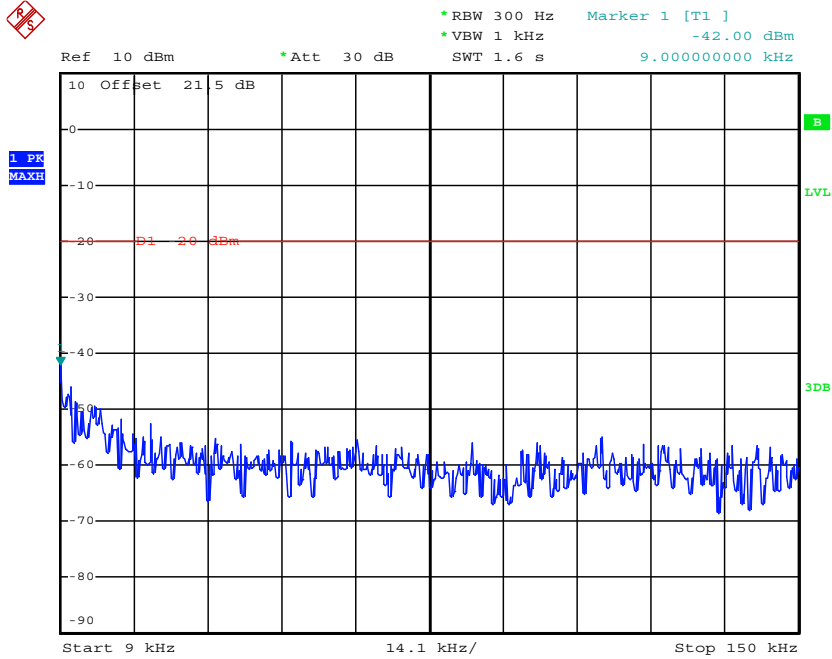

Date: 17.MAY.2016 22:32:49

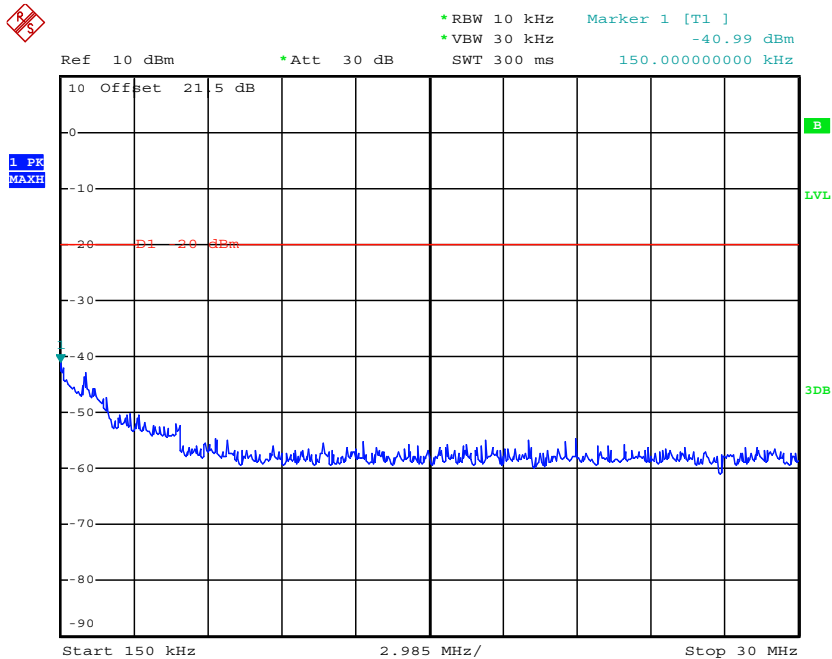

Date: 17.MAY.2016 22:36:10

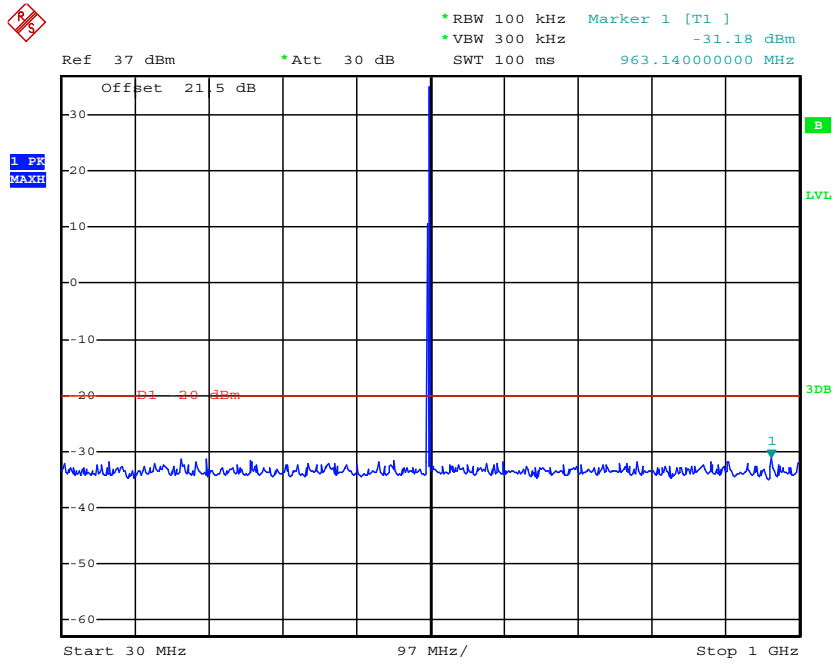

Date: 17.MAY.2016 22:50:08

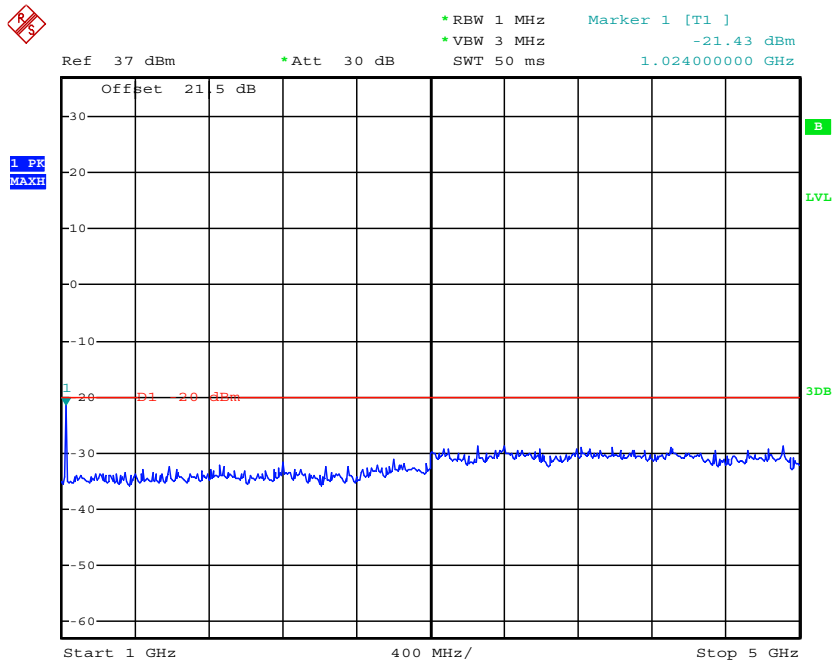

Date: 17.MAY.2016 22:59:02

Operation Mode	Test Channel	Test Frequency (MHz)	Maximum Conducted Spurious Emissions Below 1GHz		Maximum Conducted Spurious Emissions Above 1GHz		Limit (dBm)
			Frequency (MHz)	Data (dBm)	Frequency (MHz)	Data (dBm)	
Op 3	Ch4	450.025	901.60	-20.89	4480.00	-28.56	-20.00

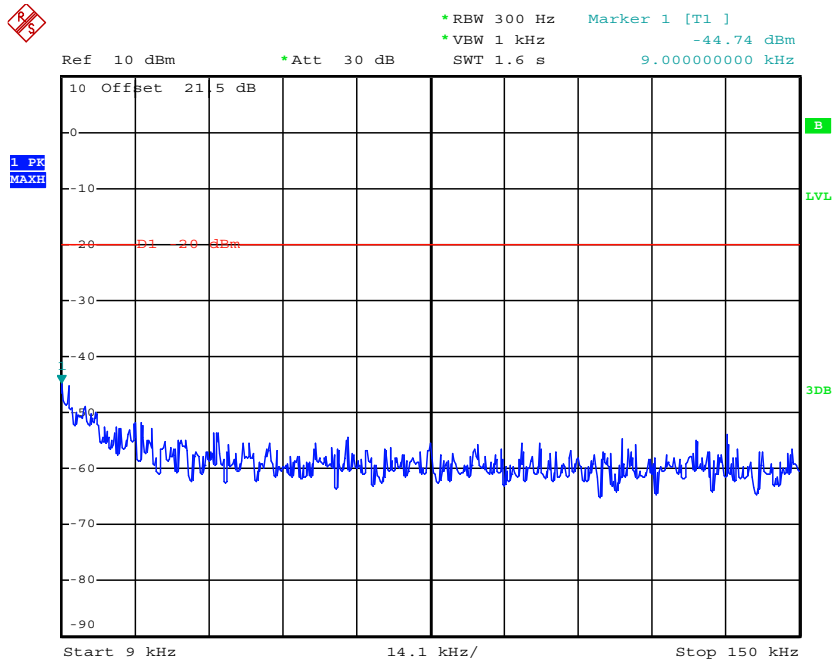

Date: 17.MAY.2016 22:33:00

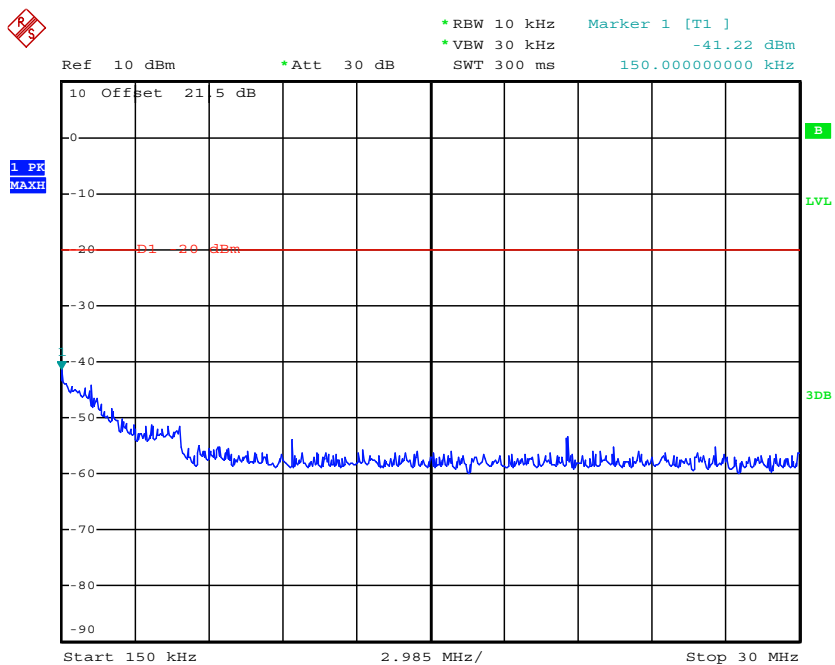

Date: 17.MAY.2016 22:35:58

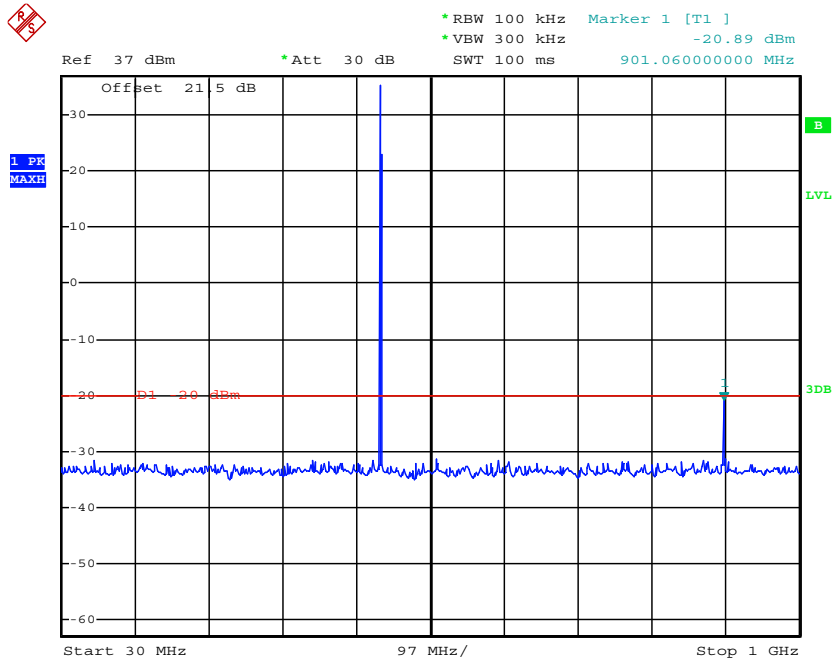

Date: 17.MAY.2016 22:52:53

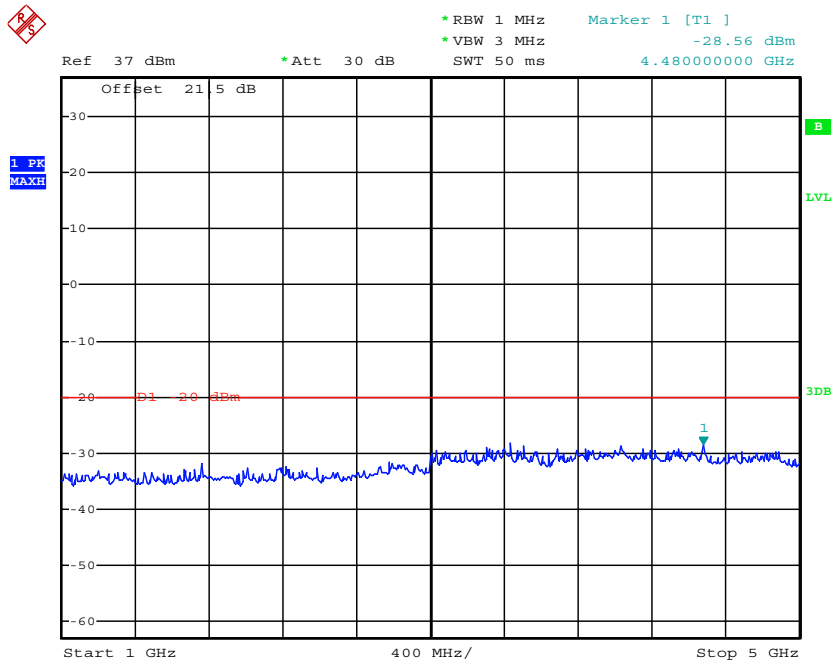

Date: 17.MAY.2016 23:00:08

Operation Mode	Test Channel	Test Frequency (MHz)	Maximum Conducted Spurious Emissions Below 1GHz		Maximum Conducted Spurious Emissions Above 1GHz		Limit (dBm)
			Frequency (MHz)	Data (dBm)	Frequency (MHz)	Data (dBm)	
Op 3	Ch5	467.775	935.98	-21.49	3376.00	-28.96	-20.00

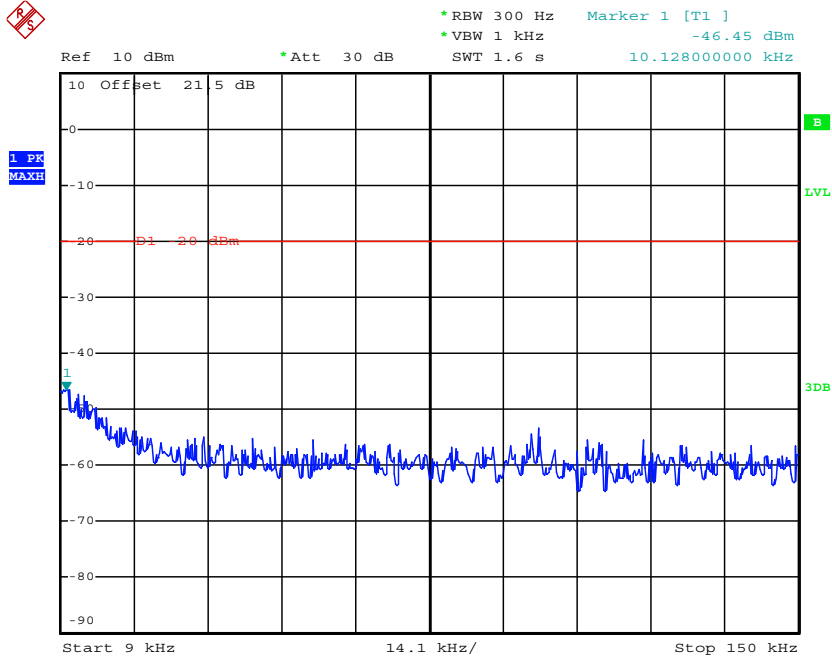

Date: 17.MAY.2016 22:33:11

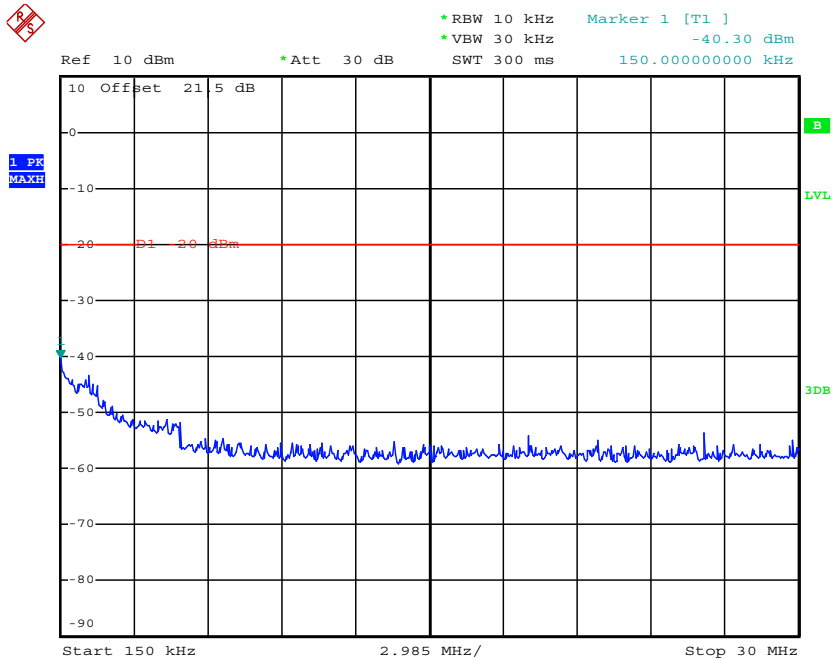

Date: 17.MAY.2016 22:35:46

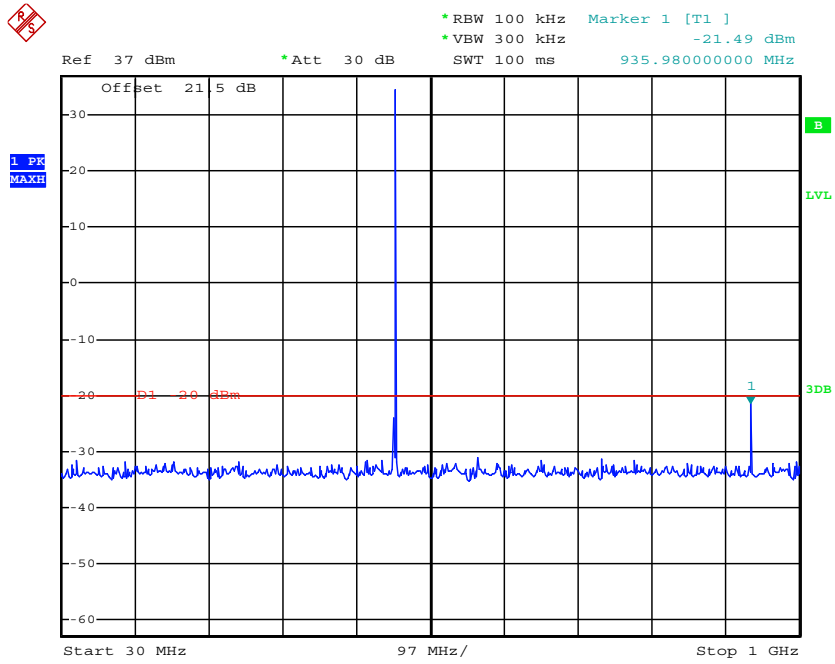

Date: 17.MAY.2016 22:52:04

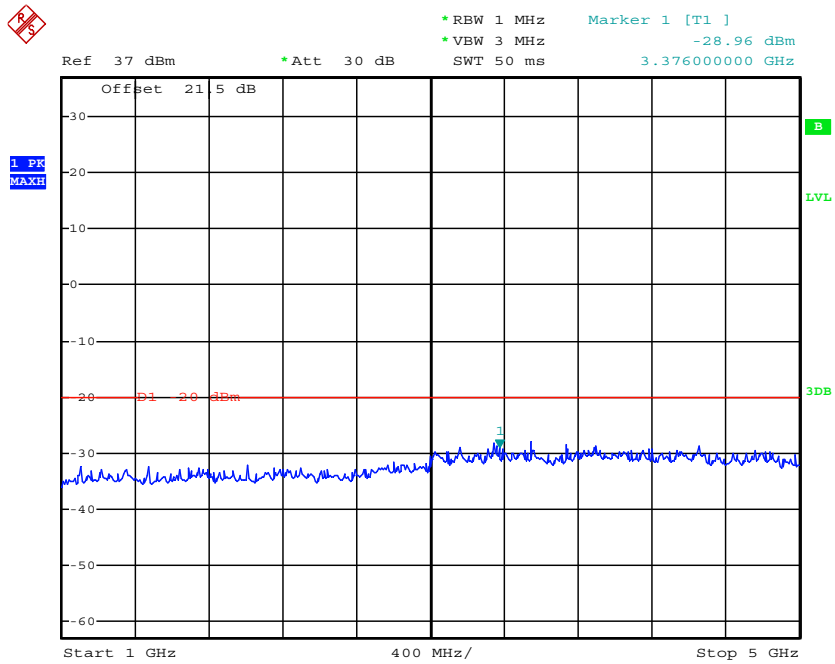

Date: 17.MAY.2016 23:00:18

Operation Mode	Test Channel	Test Frequency (MHz)	Maximum Conducted Spurious Emissions Below 1GHz		Maximum Conducted Spurious Emissions Above 1GHz		Limit (dBm)
			Frequency (MHz)	Data (dBm)	Frequency (MHz)	Data (dBm)	
Op 3	Ch6	511.9875	774.96	-31.04	1024.00	-21.10	-20.00

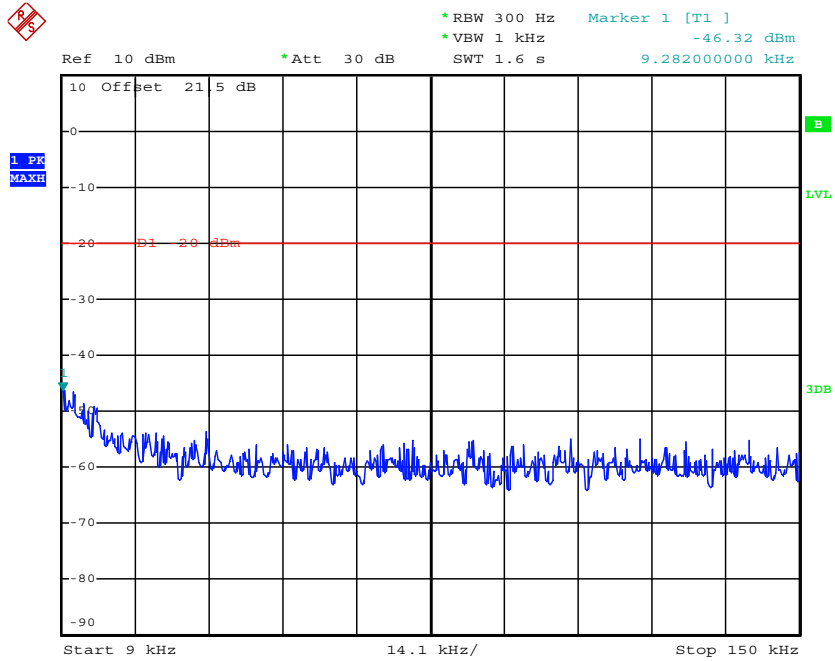

Date: 17.MAY.2016 22:33:21

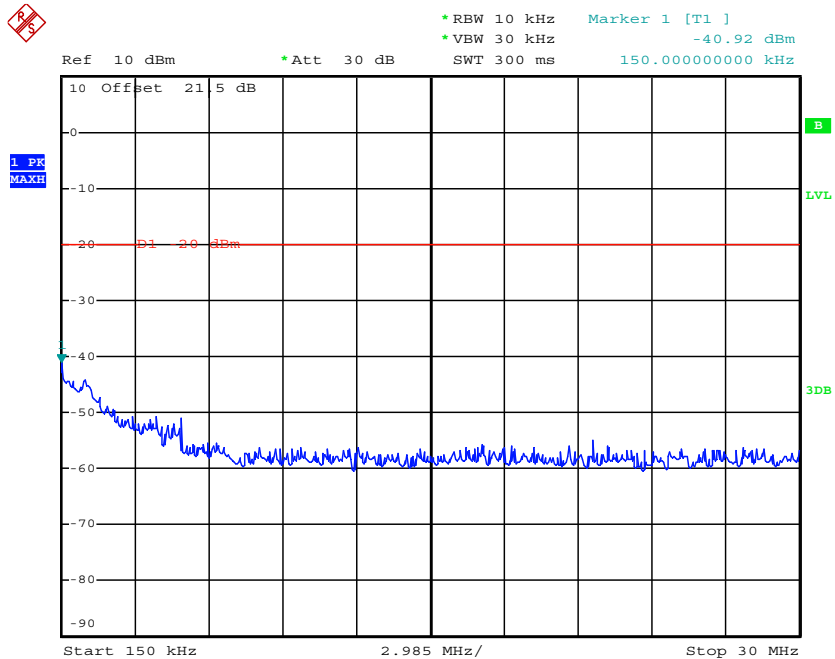

Date: 17.MAY.2016 22:35:08



Ref 37 dBm *Att 30 dB *RBW 100 kHz Marker 1 [T1]
*VBW 300 kHz -31.04 dBm
SWT 100 ms 774.960000000 MHz

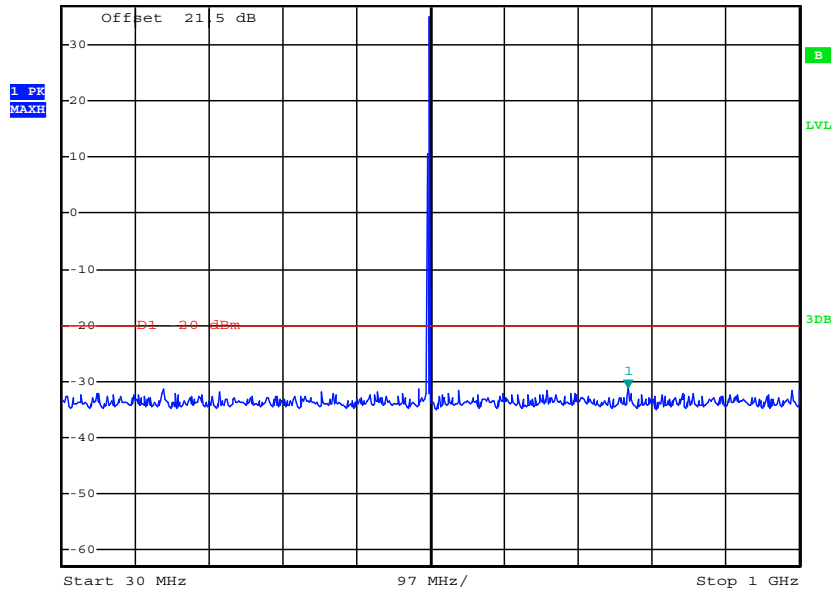

Date: 17.MAY.2016 22:50:36



Ref 37 dBm *Att 30 dB *RBW 1 MHz Marker 1 [T1]
*VBW 3 MHz -21.10 dBm
SWT 50 ms 1.024000000 GHz

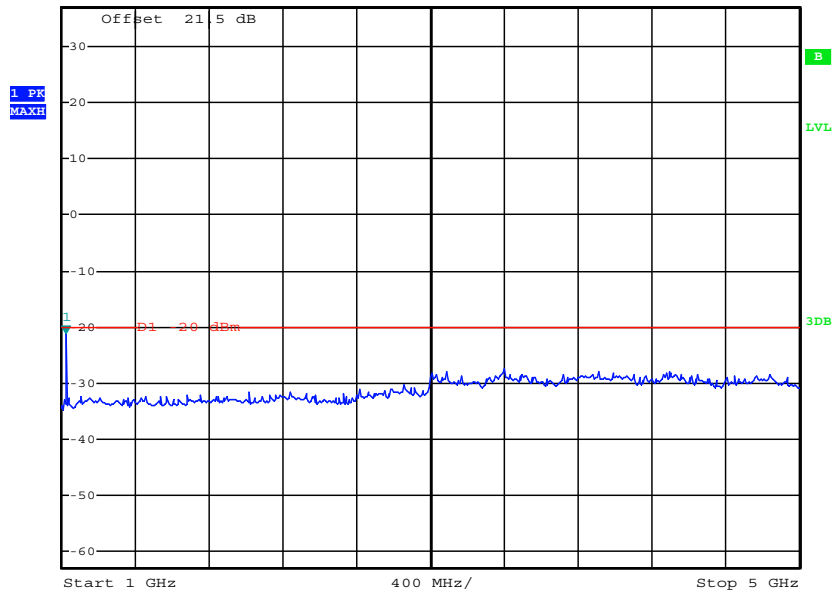

Date: 17.MAY.2016 22:58:00

4.5. Modulation Characteristics

TEST APPLICABLE

According to CFR47 section 2.1047(a), for Voice Modulation Communication Equipment, the frequency response of the audio modulation circuit over a range of 100 to 5000Hz shall be measured.

TEST PROCEDURE

Modulation Limit

- 1 Configure the EUT as shown in figure 1, adjust the audio input for 60% of rated system deviation at 1 KHz using this level as a reference (0dB) and vary the input level from -20 to +20dB. Record the frequency deviation obtained as a function of the input level.
- 2 Repeat step 1 with input frequency changing to 300, 1004, 1500 and 2500Hz in sequence.

Audio Frequency Response

- 1 Configure the EUT as shown in figure 1.
- 2 Adjust the audio input for 20% of rated system deviation at 1 KHz using this level as a reference (0dB).
- 3 Vary the Audio frequency from 100 Hz to 3 KHz and record the frequency deviation.
- 4 Audio Frequency Response = $20\log_{10}$ (Deviation of test frequency/Deviation of 1 KHz reference).

TEST CONFIGURATION

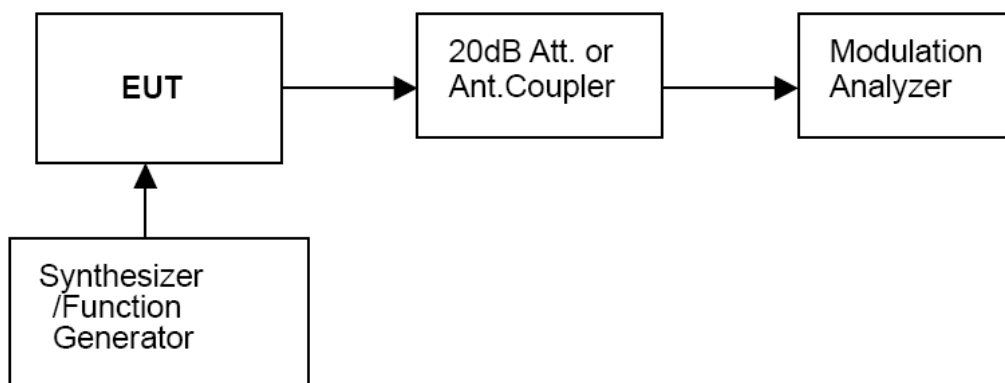

TEST RESULTS

Remark: We tested Op 1 to Op 2 recorded worst case at Op 1.

Modulation Type: FM**12.5 KHz Channel Separation Op1**

Modulation Level (dB)	Peak Freq. Deviation At 300 Hz (KHz)	Peak Freq. Deviation At 1004 Hz (KHz)	Peak Freq. Deviation At 1500 Hz (KHz)	Peak Freq. Deviation At 2500 Hz (KHz)
-20	0.12	0.19	0.31	0.57
-15	0.17	0.36	0.59	0.78
-10	0.20	0.58	0.82	1.34
-5	0.28	0.94	1.33	2.06
0	0.49	1.55	2.20	2.23
+5	0.77	2.25	2.26	2.23
+10	1.48	2.26	2.26	2.23
+15	2.20	2.26	2.26	2.23
+20	2.22	2.26	2.26	2.23

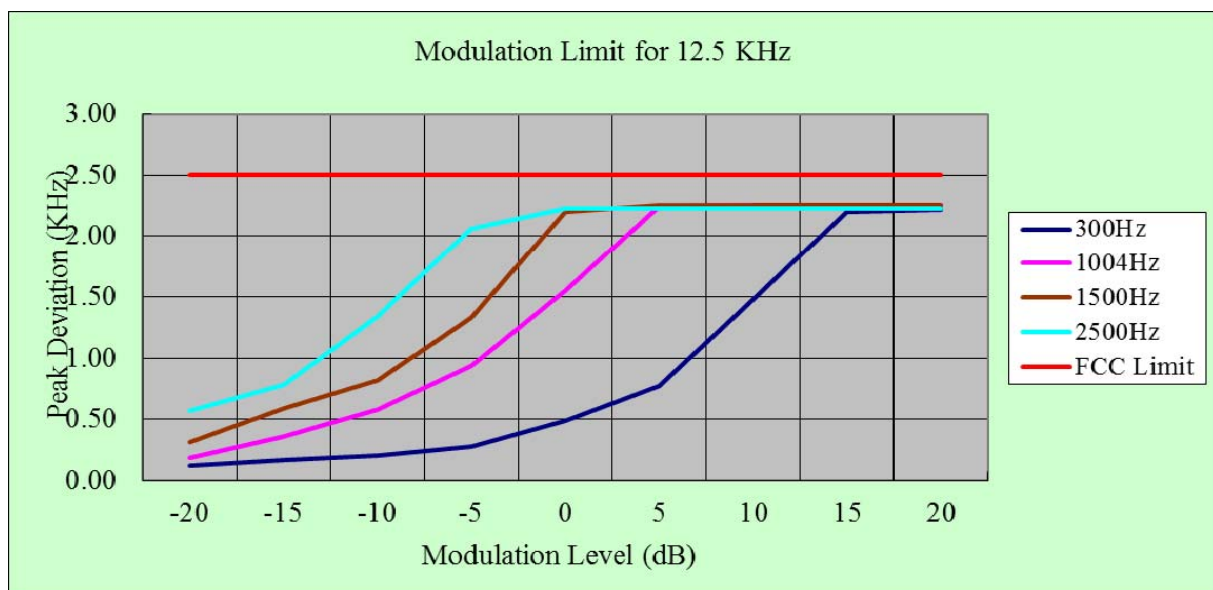
**Modulation type: 4FSK**

Channel bandwidth: 12.5 kHz

It is not applicable for devices which operate with the digitized voice/data modulation type.

b). Audio Frequency Response:

Rule Part No.: Part 2.1407(a) (b)

Method of Measurement:

The audio frequency response was measured in accordance with TIA/EIA Specification 603 with no exception.

A curve or equivalent data showing the frequency response of the audio modulating circuit over a range of 300-3000Hz shall be submitted and Audio Post Limiter Low Pass Filter Response from 3.0 KHz to 50KHz. However, the audio frequency response should test from 100Hz to 5.0 KHz according to FCC Part 90.

Modulation Type: FM

The audio frequency response curve is show below.

Test Audio Level (1 KHz and 20% maximum deviation) for 12.5 KHz channel separation is 2.75mV.

Note:

1. Not applicable to new standard. However, tests are conducted under FCC's recommendation.
2. The Audio Frequency Response is identical for 12.5 KHz channel separation

12.5 KHz Channel Separation Op1

Frequency (KHz)	Frequency Deviation (KHz)	1KHz Reference Deviation (KHz)	Audio Frequency Response (dB)
0.1	0.05	0.55	-20.83
0.2	0.05	0.55	-20.83
0.3	0.13	0.55	-12.53
0.4	0.22	0.55	-7.96
0.5	0.25	0.55	-6.85
0.6	0.28	0.55	-5.86
0.7	0.39	0.55	-2.99
0.8	0.47	0.55	-1.37
0.9	0.51	0.55	-0.66
1.0	0.55	0.55	0.00
1.2	0.64	0.55	1.32
1.4	0.71	0.55	2.22
1.6	0.79	0.55	3.15
1.8	0.84	0.55	3.68
2.0	0.89	0.55	4.18
2.2	1.05	0.55	5.62
2.4	1.11	0.55	6.10
2.6	1.14	0.55	6.33
2.7	1.21	0.55	6.85
2.8	1.26	0.55	7.20
3.0	1.29	0.55	7.40
3.5	1.29	0.55	7.40
4.0	0.05	0.55	-20.83
4.5	0.05	0.55	-20.83
5.0	0.05	0.55	-20.83

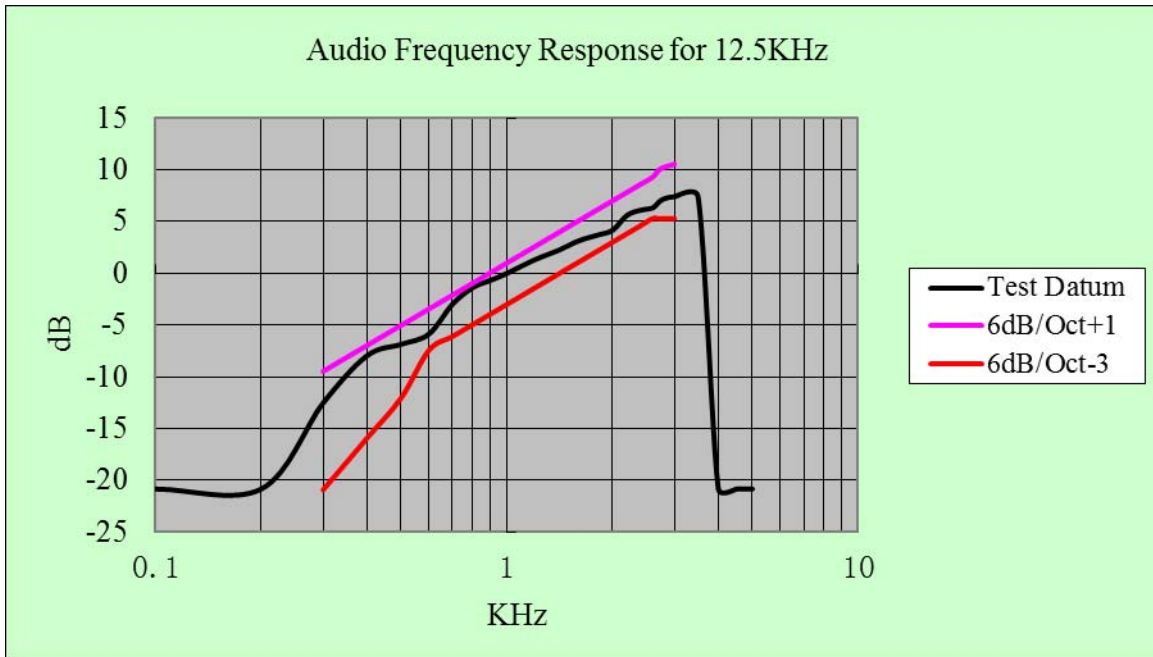

Modulation type: 4FSK

Channel bandwidth: 12.5 kHz

It is not applicable for devices which operate with the digitized voice/data modulation type.

4.6. Frequency Stability Test

TEST APPLICABLE

- 1 According to FCC Part 2 Section 2.1055 (a)(1), the frequency stability shall be measured with variation of ambient temperature from -30°C to $+60^{\circ}\text{C}$ centigrade.
- 2 According to FCC Part 2 Section 2.1055 (e) (2), for battery powered equipment, the frequency stability shall be measured with reducing primary supply voltage to the battery operating end point, which is specified by the manufacture.
- 3 Vary primary supply voltage from 85 to 115 percent of the nominal value.
- 4 According to §90.213, the frequency stability limit is 2.5 ppm for 12.5KHz channel separation

TEST PROCEDURE

The EUT was set in the climate chamber and connected to an external DC power supply. The RF output was directly connected to Spectrum Analyzer ESPI7. The coupling loss of the additional cables was recorded and taken in account for all the measurements. After temperature stabilization (approx. 20 min for each stage), the frequency for the lower, the middle and the highest frequency range was recorded. For Frequency stability Vs. Voltage the EUT was connected to a DC power supply and the voltage was adjusted in the required ranges. The result was recorded.

TEST CONFIGURATION

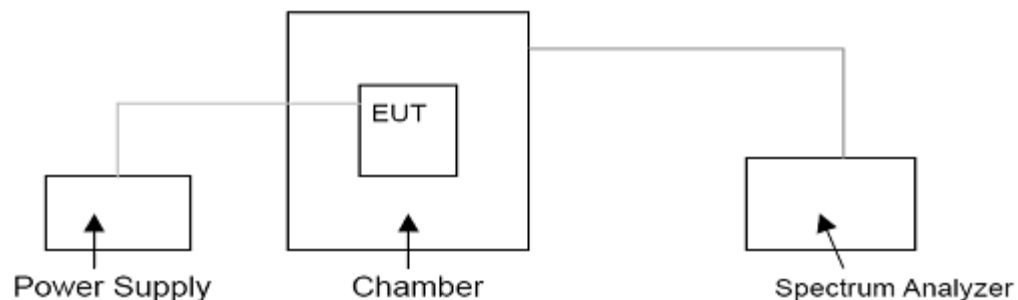

TEST LIMITS

According to 90.213, Transmitters used must have minimum frequency stability as specified in the following table.

Frequency Range (MHz)	Channel Bandwidth (KHz)	Frequency Tolerance (ppm)		
		Fixed and Base Stations	Mobile Stations	
			> 2 W	≤ 2 W
150-174 MHz	6.25	1.0	2.0	2.0
	12.5	2.5	5.0	5.0
	25	5.0	5.0	50.0*
421-512 MHz	6.25	0.5	1.0	1.0
	12.5	1.5	2.5	2.5
	25	2.5	5.0	5.0

- Stations operating in the 154.45 to 154.49 MHz or the 173.2 to 173.4 MHz bands must have a frequency stability of 5 ppm.
- Paging transmitters operating on paging-only frequencies must operate with frequency stability of 5 ppm in the 150-174 MHz band and 2.5 ppm in the 421-512 MHz band.

TEST RESULTS

Remark: We tested Op 1 to Op 4, recorded worst case at Op 1 and Op 3.

Operation Mode	Channel Separation	Test conditions		Frequency error (ppm)		
		Voltage(V)	Temp(°C)	450.025	467.775	511.9875
Op1	12.5KHz	7.4 V	-30	0.97	0.18	0.17
			-20	0.61	0.66	0.27
			-10	0.88	0.10	0.99
			0	0.54	0.19	0.19
			10	0.53	0.68	0.35
			20	0.20	0.94	0.48
			30	0.47	0.82	0.42
			40	0.17	0.81	0.22
			50	0.48	0.69	0.05
		6.29 (85% Rated)	20	0.55	0.93	0.85
		8.51(115% Rated)	20	0.78	0.80	0.89
Limit		2.5 ppm				
Test Results		PASS				

Operation Mode	Channel Separation	Test conditions		Frequency error (ppm)		
		Voltage(V)	Temp(°C)	450.025	467.775	511.9875
Op3	12.5KHz	7.4 V	-30	0.66	0.46	0.71
			-20	0.42	0.81	0.03
			-10	0.50	0.75	0.37
			0	0.25	0.51	0.03
			10	0.96	0.52	0.54
			20	0.04	0.31	0.95
			30	0.58	0.48	0.02
			40	0.42	0.87	0.67
			50	0.70	0.73	0.87
		6.29 (85% Rated)	20	0.08	0.48	0.81
		8.51(115% Rated)	20	0.26	0.79	0.73
Limit		2.5 ppm				
Test Results		PASS				

4.7. Maximum Transmitter Power

TEST APPLICABLE

Per FCC Part 2.1046 and Part 90.205: Maximum ERP is dependent upon the station's antenna HAAT and required service area.

Per RSS-119 Section 5.4 and 5.4.1: The output power shall be within ± 1.0 dB of the manufacturer's rated power. Typical transmitter output powers are 110 watts for base and/or fixed stations (paging transmitters excepted), and 30 watts for mobile stations. Higher powers may be certified, but it should be noted that mobile stations are normally only licensed up to 30 watts. See the SRSP relevant to the operating frequency for equipment power limits.

TEST PROCEDURE

Measurements shall be made to establish the radio frequency power delivered by the transmitter the standard output termination. The power output shall be monitored and recorded and no adjustment shall be made to the transmitter after the test has begun, except as noted bellow:

If the power output is adjustable, measurements shall be made for the highest and lowest power levels. The EUT connect to the Receiver through 20 dB attenuator.

Measurement with Spectrum Analyzer ESPI7 for conducted measurement, external power supply with 7.4 V stabilized supply voltage.

TEST CONFIGURATION

EUT		Attenuator		Spectrum Analyzer/Receiver

The EUT was directly connected to a RF Communication
Test set by a 20 dB attenuator

TEST RESULTS

Modulation Type	Channel Separation	Operation Mode	Test Channel	Test Frequency (MHz)	Test Results (dBm)
Analog/FM	12.5KHz	Op 1	Ch1	450.025	36.42
			Ch2	467.775	36.02
			Ch3	511.9875	36.06
		Op 2	Ch1	450.025	30.65
			Ch2	467.775	30.25
			Ch3	511.9875	29.98
Digital/4FSK	12.5KHz	Op 3	Ch4	450.025	36.31
			Ch5	467.775	35.94
			Ch6	511.9875	36.03
		Op 4	Ch4	450.025	30.50
			Ch5	467.775	30.11
			Ch6	511.9875	29.99
Limit	The limit is dependent upon the station's antenna HAAT and required service area.				
Test Results	PASS				

Plots of Transmitter Power Measurement

Modulation Type	Channel Separation	Operation Mode	Test Channel	Test Frequency (MHz)	Rated Power (Watt)	Measurement (dBm)	Limit	Results
FM	12.5KHz	Op 1	Ch1	450.025	4.0	36.42	Varies	PASS

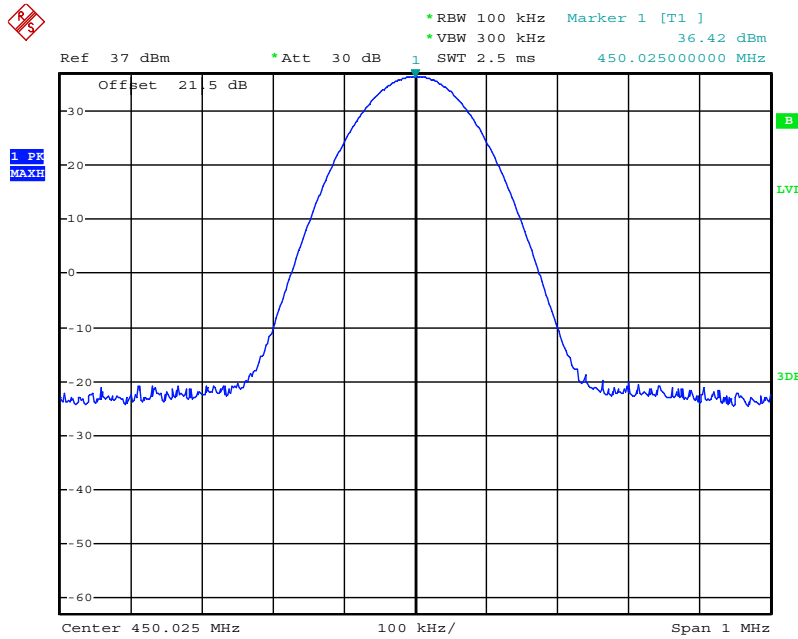

Date: 17.MAY.2016 21:32:57

Modulation Type	Channel Separation	Operation Mode	Test Channel	Test Frequency (MHz)	Rated Power (Watt)	Measurement (dBm)	Limit	Results
FM	12.5KHz	Op 1	Ch2	467.775	4.0	36.02	Varies	PASS

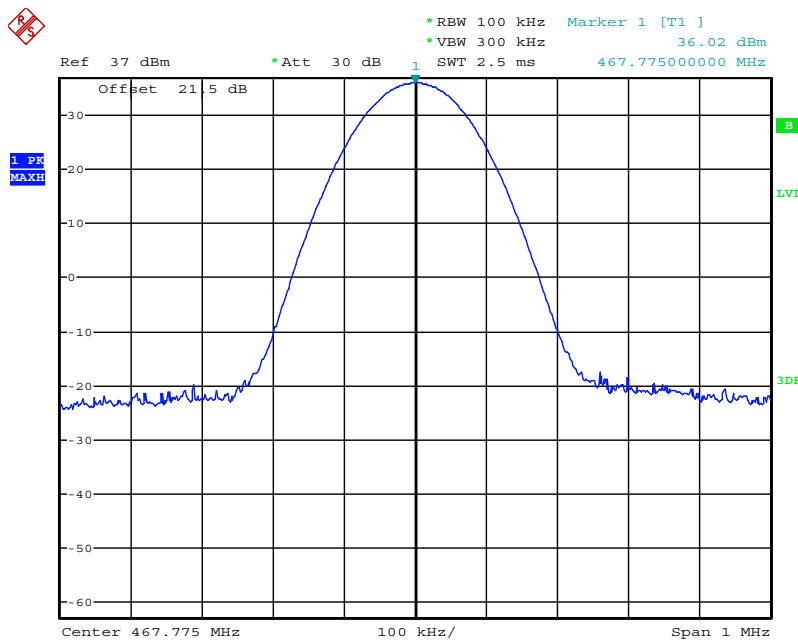

Date: 17.MAY.2016 21:34:23

Modulation Type	Channel Separation	Operation Mode	Test Channel	Test Frequency (MHz)	Rated Power (Watt)	Measurement (dBm)	Limit	Results
FM	12.5KHz	Op 1	Ch3	511.9875	4.0	36.06	Varies	PASS

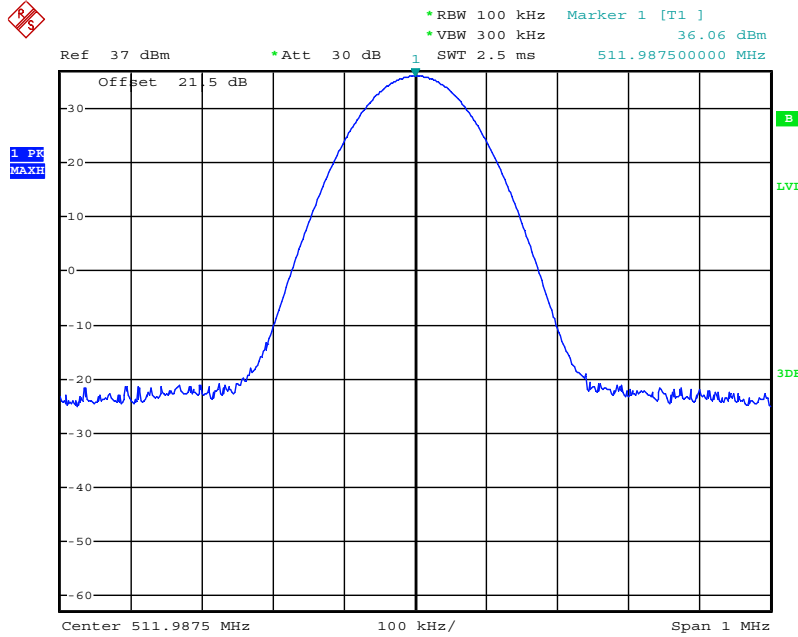

Date: 17.MAY.2016 21:56:30

Modulation Type	Channel Separation	Operation Mode	Test Channel	Test Frequency (MHz)	Rated Power (Watt)	Measurement (dBm)	Limit	Results
FM	12.5KHz	Op 2	Ch1	450.025	1	30.65	Varies	PASS

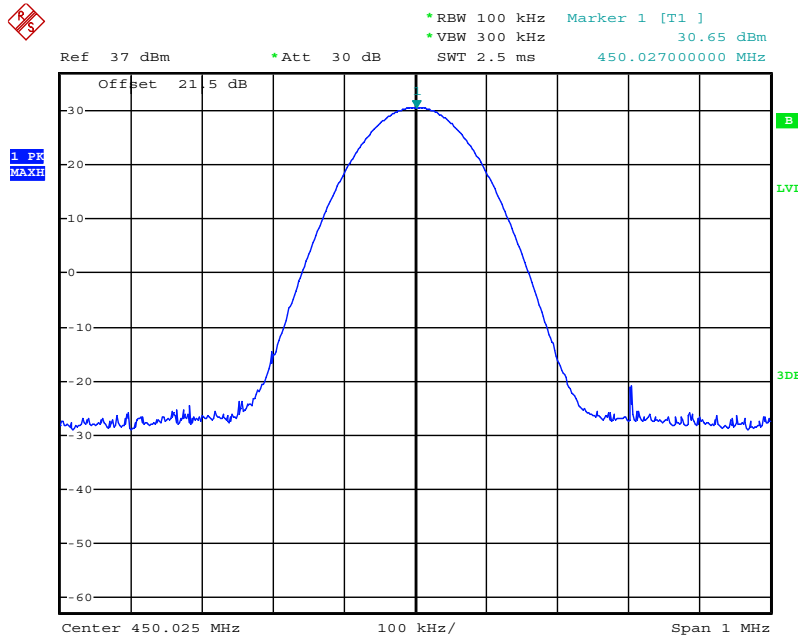

Date: 17.MAY.2016 21:37:15

Modulation Type	Channel Separation	Operation Mode	Test Channel	Test Frequency (MHz)	Rated Power (Watt)	Measurement (dBm)	Limit	Results
FM	12.5KHz	Op 2	Ch2	467.775	1	30.25	Varies	PASS

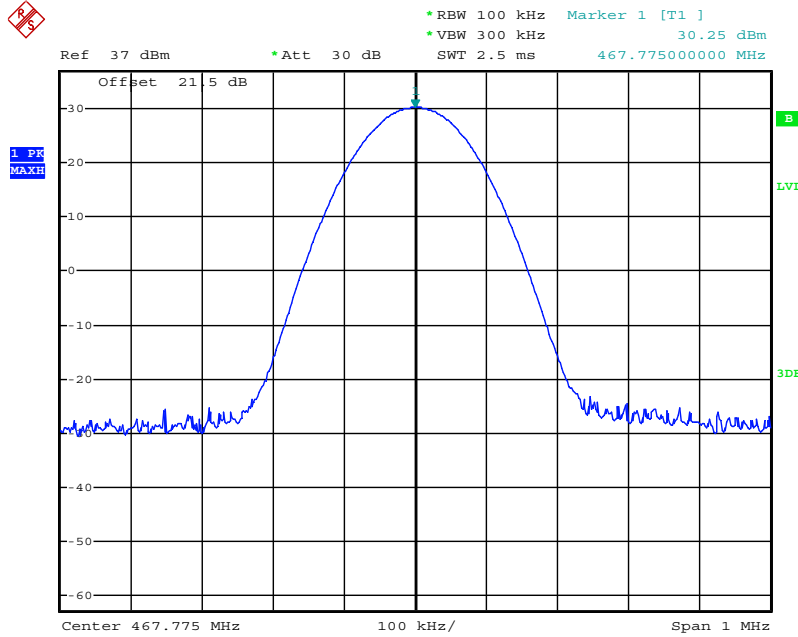

Date: 17.MAY.2016 21:35:51

Modulation Type	Channel Separation	Operation Mode	Test Channel	Test Frequency (MHz)	Rated Power (Watt)	Measurement (dBm)	Limit	Results
FM	12.5KHz	Op 2	Ch3	511.9875	1	29.98	Varies	PASS

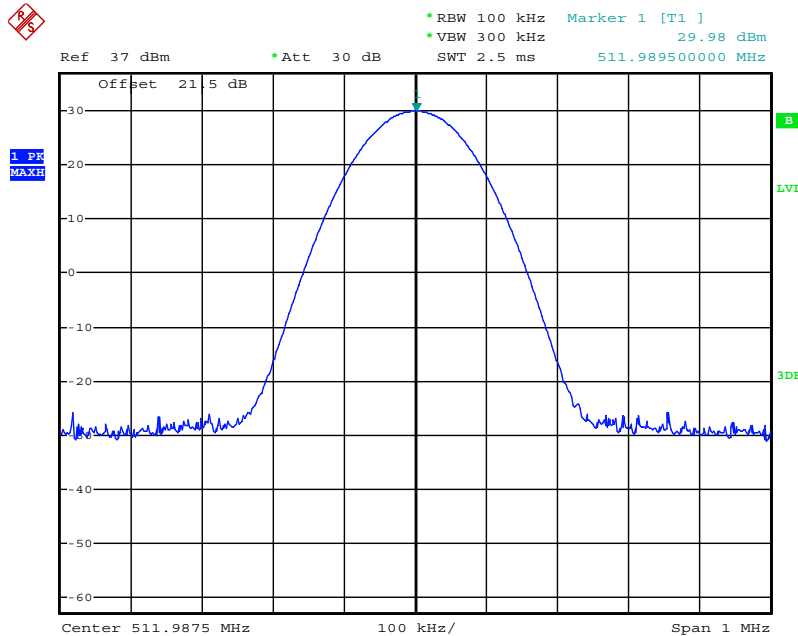

Date: 17.MAY.2016 21:56:10

Modulation Type	Channel Separation	Operation Mode	Test Channel	Test Frequency (MHz)	Rated Power (Watt)	Measurement (dBm)	Limit	Results
4FSK	12.5KHz	Op 3	Ch4	450.025	4.0	36.31	Varies	PASS

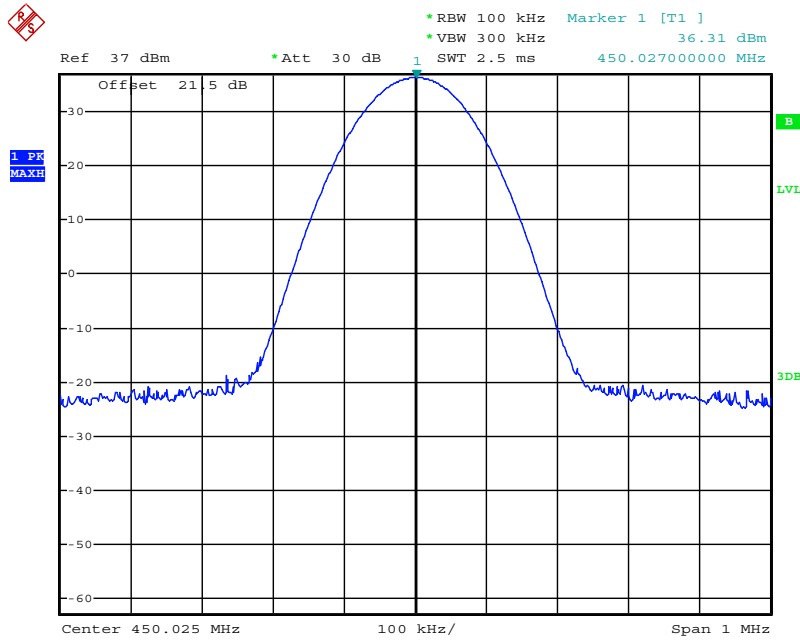

Date: 17.MAY.2016 21:57:32

Modulation Type	Channel Separation	Operation Mode	Test Channel	Test Frequency (MHz)	Rated Power (Watt)	Measurement (dBm)	Limit	Results
4FSK	12.5KHz	Op 3	Ch5	467.775	4.0	35.94	Varies	PASS

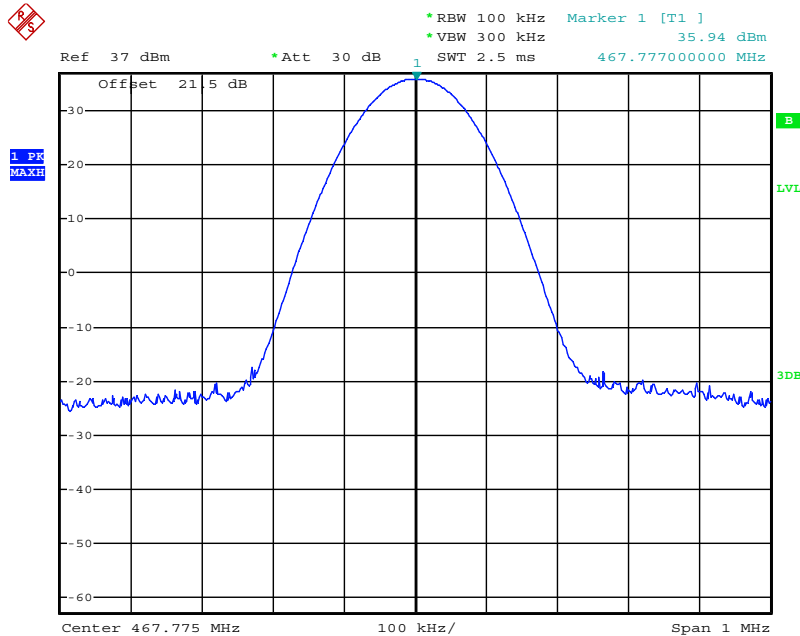

Date: 17.MAY.2016 21:58:03

Modulation Type	Channel Separation	Operation Mode	Test Channel	Test Frequency (MHz)	Rated Power (Watt)	Measurement (dBm)	Limit	Results
4FSK	12.5KHz	Op 3	Ch6	511.9875	4.0	36.03	Varies	PASS

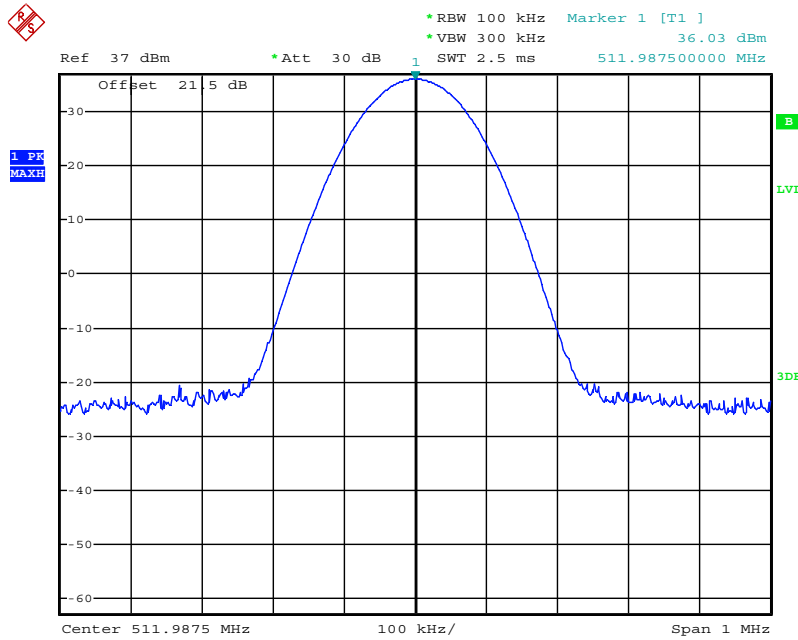

Date: 17.MAY.2016 21:56:50

Modulation Type	Channel Separation	Operation Mode	Test Channel	Test Frequency (MHz)	Rated Power (Watt)	Measurement (dBm)	Limit	Results
4FSK	12.5KHz	Op 4	Ch4	450.025	1	30.50	Varies	PASS

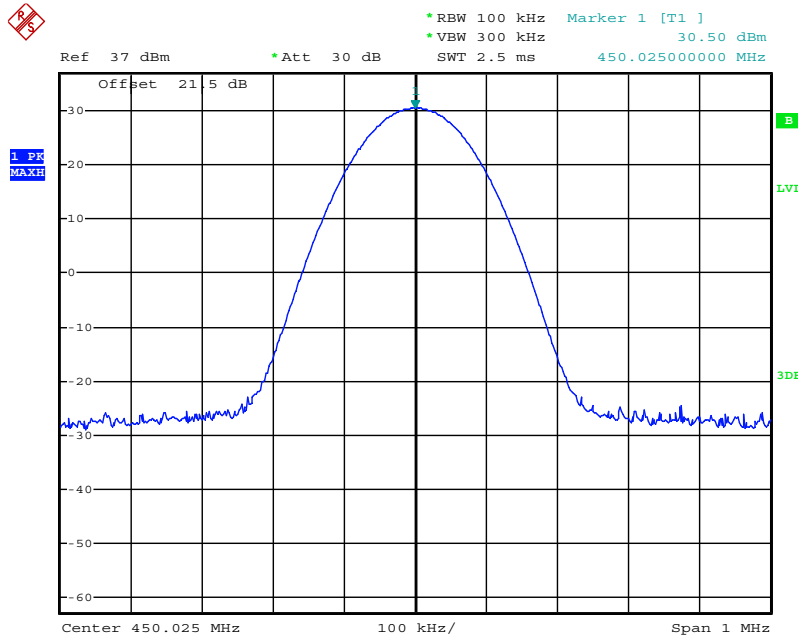

Date: 17.MAY.2016 21:48:49

Modulation Type	Channel Separation	Operation Mode	Test Channel	Test Frequency (MHz)	Rated Power (Watt)	Measurement (dBm)	Limit	Results
4FSK	12.5KHz	Op 4	Ch5	467.775	1	30.11	Varies	PASS

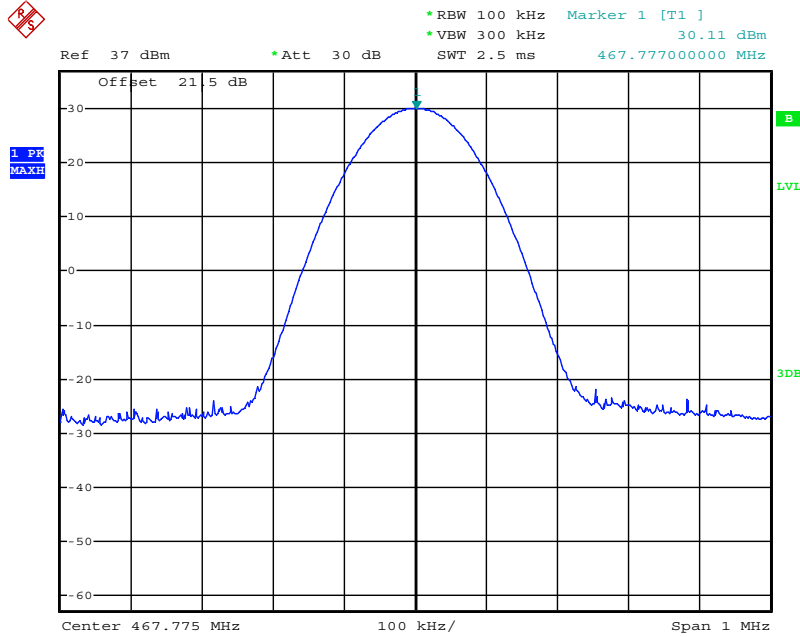

Date: 17.MAY.2016 21:53:24

Modulation Type	Channel Separation	Operation Mode	Test Channel	Test Frequency (MHz)	Rated Power (Watt)	Measurement (dBm)	Limit	Results
4FSK	12.5KHz	Op 4	Ch6	511.9875	1	29.99	Varies	PASS

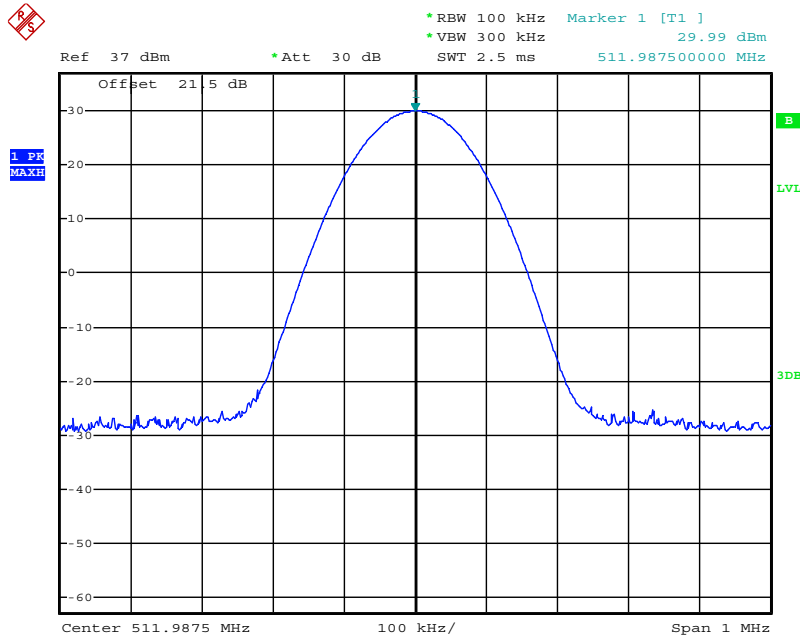

Date: 17.MAY.2016 21:55:41

4.8. Transmitter Frequency Behavior

TEST APPLICABLE

Section 90.214

Transient frequencies must be within the maximum frequency difference limits during the time intervals indicated:

Time intervals ^{1, 2}	Maximum frequency difference ³	All equipment	
		150 to 174 MHz	421 to 512MHz
Transient Frequency Behavior for Equipment Designed to Operate on 25 KHz Channels			
t ₁ ⁴	± 25.0 KHz	5.0 ms	10.0 ms
t ₂ ⁴	± 12.5 KHz	20.0 ms	25.0 ms
t ₃ ⁴	± 25.0 KHz	5.0 ms	10.0 ms
Transient Frequency Behavior for Equipment Designed to Operate on 12.5 KHz Channels			
t ₁ ⁴	± 12.5 KHz	5.0 ms	10.0 ms
t ₂ ⁴	± 6.25 KHz	20.0 ms	25.0 ms
t ₃ ⁴	± 12.5 KHz	5.0 ms	10.0 ms
Transient Frequency Behavior for Equipment Designed to Operate on 6.25 KHz Channels			
t ₁ ⁴	±6.25 KHz	5.0 ms	10.0 ms
t ₂	±3.125 KHz	20.0 ms	25.0 ms
t ₃ ⁴	±6.25 KHz	5.0 ms	10.0 ms

- t_{on} is the instant when a 1 KHz test signal is completely suppressed, including any capture time due to phasing.
 t₁ is the time period immediately following t_{on}.
 t₂ is the time period immediately following t₁.
 t₃ is the time period from the instant when the transmitter is turned off until t_{off}.
 t_{off} is the instant when the 1 KHz test signal starts to rise.
- During the time from the end of t₂ to the beginning of t₃, the frequency difference must not exceed the limits specified in § 90.213.
- Difference between the actual transmitter frequency and the assigned transmitter frequency.
- If the transmitter carrier output power rating is 6 watts or less, the frequency difference during this time period may exceed the maximum frequency difference for this time period.

TEST CONFIGURATION

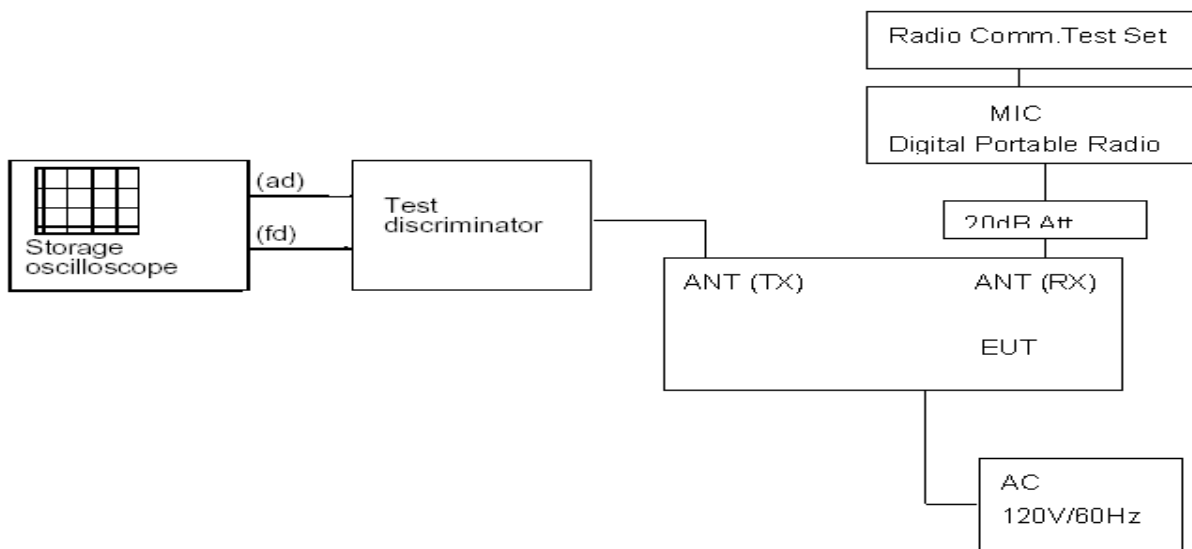

TEST PROCEDURE

According to TIA/EIA-603 2.2.19 requirement.

TEST RESULTS

Please refer to the following plots.

Modulation Type: FM

Transmitter Frequency Behavior @ 12.5 KHz Channel Separation-----Off – On

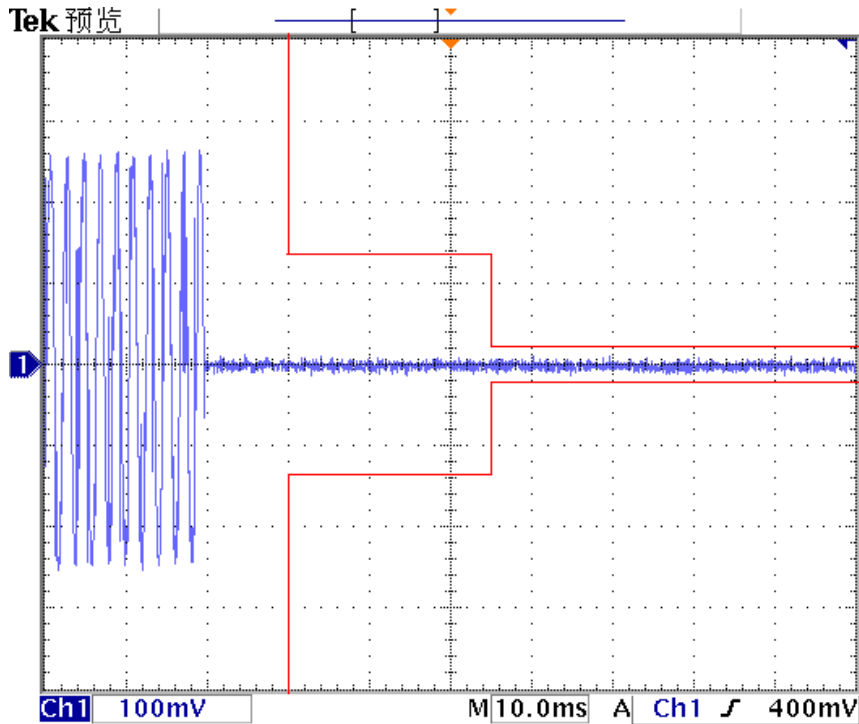

Transmitter Frequency Behavior @ 12.5 KHz Channel Separation-----On – Off

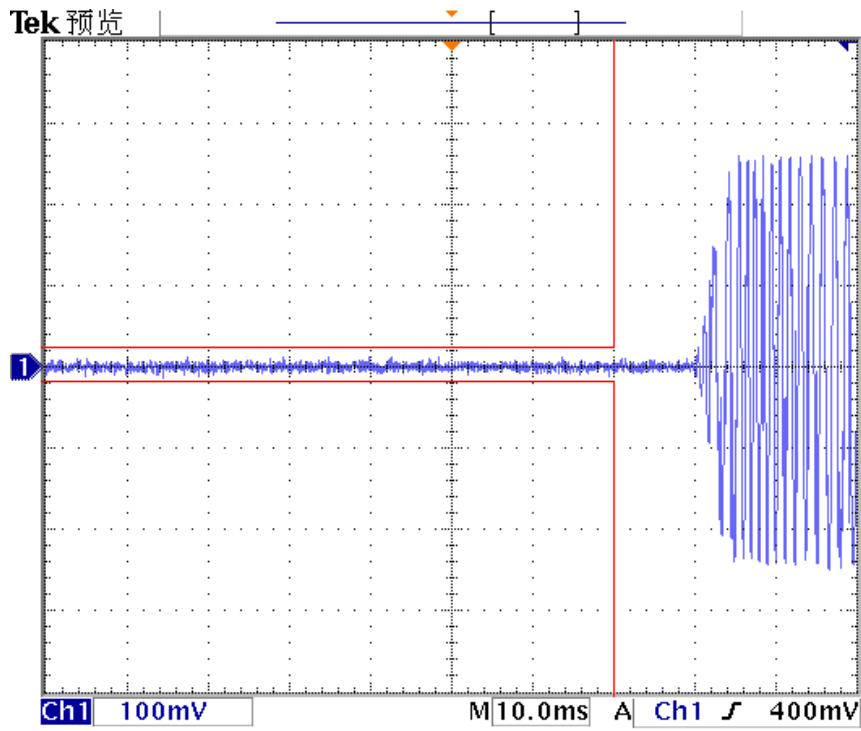

Modulation Type: 4FSK

Transmitter Frequency Behavior @ 12.5 KHz Channel Separation-----Off – On

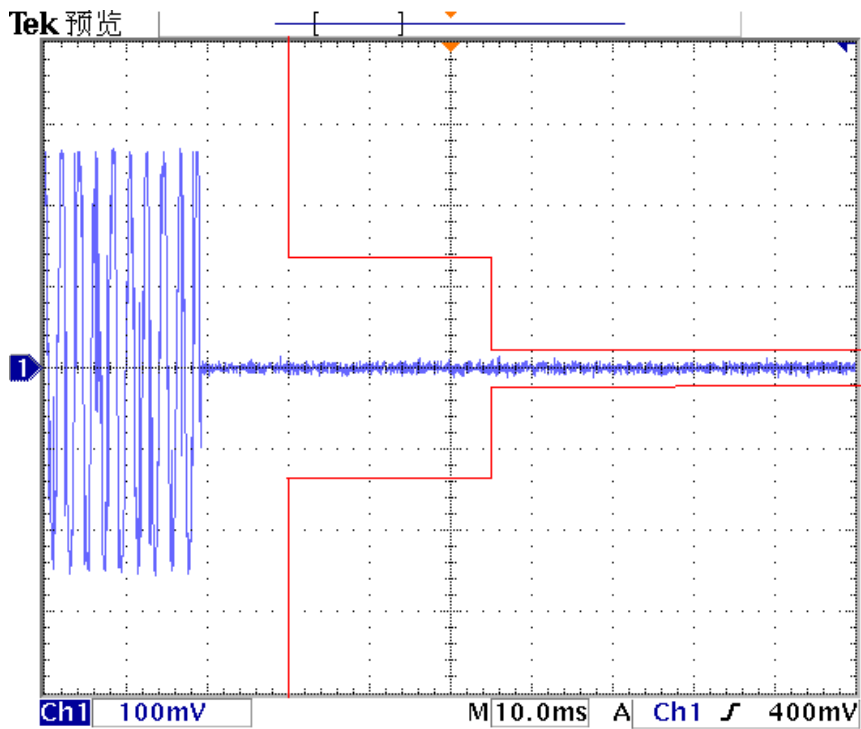

Transmitter Frequency Behavior @ 12.5 KHz Channel Separation-----On - Off

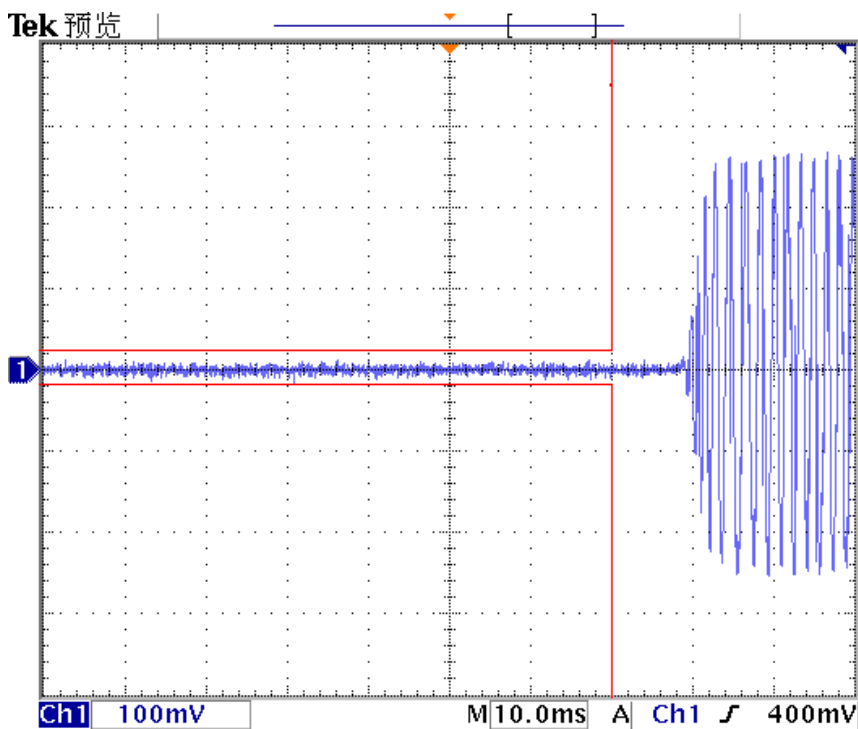

5. LIST OF MEASURING EQUIPMENT

AC Power Conducted Emission				
Name of Equipment	Manufacturer	Model	Serial Number	Cal Date
Artificial Mains	MESS Tec	NNB-2/16Z	99079	June 18,2015
EMI Test Receiver	R&S	ESCS 30	100174	June 18,2015
EMI Test Software	Audix	E3	N/A	N/A
RF COMMUNICATION TEST SET	HP	8920A	3813A10245	June 19,2015

Modulation Characteristic				
Name of Equipment	Manufacturer	Model	Serial Number	Cal Date
RF COMMUNICATION TEST SET	HP	8920A	3813A10245	June 19,2015

Frequency Stability				
Name of Equipment	Manufacturer	Model	Serial Number	Cal Date
RF COMMUNICATION TEST SET	HP	8920A	3813A10245	June 19,2015
Signal Generator	Rohde&Schwarz	SMR40	10016	July 16, 2015
Climate Chamber	Giant Force	GTH-225-20-S	MAB0103-00	June 18,2015

Maximum Transmitter Power & Spurious Emission On Antenna Port & Occupied Bandwidth & Emission Mask				
Name of Equipment	Manufacturer	Model	Serial Number	Cal Date
Receiver	Rohde&Schwarz	ESPI 7	125590	June 19,2015
RF COMMUNICATION TEST SET	HP	8920A	3813A10245	June 19,2015
High-Pass Filter	Anritsu	MP526B	6220875288	July 16, 2015
High-Pass Filter	Anritsu	MP526D	6220878442	July 16, 2015

Transient Frequency Behavior				
Name of Equipment	Manufacturer	Model	Serial Number	Cal Date
Signal Generator	Rohde&Schwarz	SMR40	10016	July 16, 2015
Storage Oscilloscope	Tektronix	TDS3054B	B033154	July 17, 2015
RF COMMUNICATION TEST SET	HP	8920A	3813A10245	June 19,2015

Transmitter Radiated Spurious Emission				
Name of Equipment	Manufacturer	Model	Serial Number	Cal Date
Receiver	Rohde&Schwarz	ESPI 7	125590	June 19,2015
EMI Test Software	Audix	E3	N/A	N/A
RF COMMUNICATION TEST SET	HP	8920A	3813A10245	June 19,2015
HORN ANTENNA	EMCO	3115	6741	June 10, 2015
HORN ANTENNA	EMCO	3115	6829	June 10, 2015
By-log Antenna	SCHWARZBECK	VULB9163	9163-470	June 10, 2015
By-log Antenna	SCHWARZBECK	VULB9163	9163-498	May 29, 2016
High-Pass Filter	Anritsu	MP526B	6220875288	July 16, 2015
High-Pass Filter	Anritsu	MP526D	6220878442	July 16, 2015

The calibration interval was one year.

.....The End of Report.....