

2U Single Frequency Base Station SIS8800 Series

* Please read this owner's manual carefully before using the products.



Owner's Manual

To user,

Thank you for choosing Shenzhen Samhoo Sci&Tech Co.,Ltd. transceiver products. To mostly enjoy the convenience of our products, please read this manual before you use the product.

Models Instruction

This manual applies to SIS8800 series products:

SIS8811 (with basic transceiving function)

SIS8813 (With IP Connection function)

SIS8816 (with IP link/DMR/pseudo simulcast functions)

SIS8819 (with trunking function)

Notes

- ◇ When operating an amateur base station, it is important to observe all the proper rules of conduct and not to cause harmful interference to other stations, during fix installed.
- ◇ Penalties will be imposed on those who operate transmitters illegally.
- ◇ Maintenance can only be carried out by professionals.

Disclaimer

During the preparation process of this manual, we sought for accuracy and completeness of its contents. Should there be any errors or omissions, we will not bear any responsibility. Due to continuous development of technology, we reserve the right not to give further notice on changes of design and specifications of our products.

For more information or if you have any suggestions on this manual, please visit our website: <http://www.samhoo.com.cn>.

Before Transmitting

When operating a base station, it is important for the user to be fully aware of the hazards brought by RF radiation, and able to take corresponding measures to meet the prescribed requirements of RF radiation.

Contents

Getting started.....	3
Front panel	3
Rear panel.....	4
Structural & Functional Features	5
Basic Operations.....	9
Installation & Module Inspection	9
Connecting the Feeder and Antenna.....	9
Power on/off.....	10
Connecting to the PC.....	17
Installation of the Satellite Module	19
Multi-channel Connection	20
IP Networking	22
Alarm Message	23
Performance Specifications	24
Troubleshooting.....	26
Care and Cleaning.....	27

Getting started

Front panel

Remove the front panel, you can see the structure of the base station as follows:

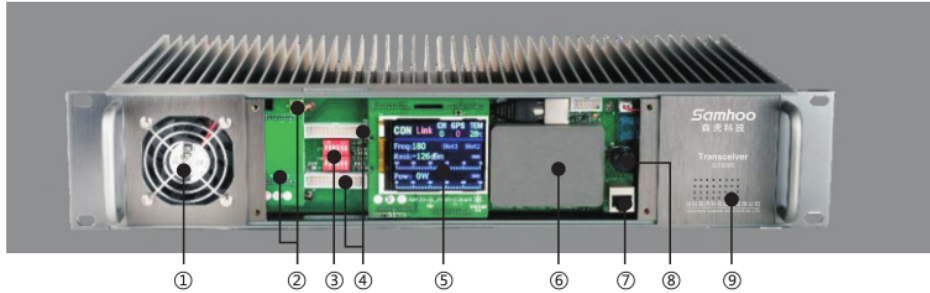

Figure1 - Front panel

1. Temperature control fan: used for heat dissipation, when the temperature is detected to be above 45°C, it rotates to enhance dissipation of the equipment.
2. Satellite module: The satellite module works with satellite antenna, which is installed in the upper right corner of the satellite module. Note: Some models are not equipped with satellite module.
3. Dip switch: There are six dip switches, which is switched to ON (upward) indicates which audio channel will be used. Settings of dip switch of base stations are similar to those of the network management terminal, see P21.
4. Bus slot: Each base station contains two bus slots, each slot can be connected to a base station or a base station controller. When a base station has multiple channels, base stations connect together through bus connection, see P21.
5. LCD display: displays operation status of a channel, including channel number,

position fix, temperature, field strength, power and other information, see P7.

6. CCM module: carrier controller, work mode of base station can be set via software.

7. Local management port: with a dedicated coder, you can manage relevant information settings of the base station. See P11 for cabling sequence and setting methods in detail.

8. Operating knob: used for operating the channel menu, and currently can be used to control the speaker switch.

9. Speaker: in analog mode, when the speaker is enabled, you can monitor the current call.

Rear panel

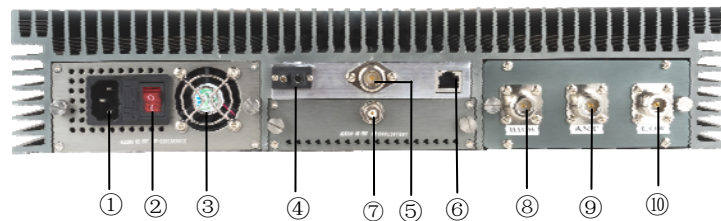

Figure2 - Rear Panel

From Fig.2, you see the rear view of the base station, which consists of four modules, i.e., the power supply module on the left, power amplifier module in the upper middle, TX&RX module in the lower middle, and the duplexer module on the right.

1. Power supply port: connect to 220V AC power supply.

2. Power switch & LED indicator: switch to “I” to turn on the power; switch to “O” to cut off the power. The LED indicator lights up red when the power is on.

3. Cooling fan: The moment when the power is turned on, the cooling fan rotates for about 2 seconds; When the base station is in operation and the temperature is over 45°C, the fan starts to rotate for dissipation.
4. Battery port: 12V power supply or battery power supply. When the power supply module (220V) is in normal operation, the port is in charging/idle state, functioning as a standby power supply; In case of power module failure/power cut-off, the standby power is used. When connecting the standby power, take care to the polarity of power supply.
5. Amplifier output port: the amplifier power output port of base station. Maximum power output: 50~60W.
6. IP port: used for IP networking. It applies the international standard line sequence.
7. TX&RX module port: input port of receiving signals.
8. High end of the duplexer: input/output port of high frequency signals
9. ANT port: antenna interface
10. Low end of the duplexer: input/output port of low frequency signals



Note: Locations of the above ports are subject to changes. If there is any inconsistency of port sequence in the actual product you receive, the actual product will govern.

Structural & Functional Features

Structural Features:

1. Fit for the 19 inch standard cabinet
2. All-aluminum alloy workmanship & large-area heat dissipation design
3. Configured with a broadband duplexer slot, and optional built-in duplexer
4. Realizing integration of the CCM module, TX&RX module, power supply module and duplexer, and can be put to used after attaching the antenna, even without an engineering cabinet.
5. All modules can be replaced easily, and you can choose modules flexibly according to your actual needs.
6. Equipped with the 120V power module and battery port, preventing communication shut down because of power off.
7. LCD screen for displaying information such as transmit and receive condition, temperature, satellite, power and so on.
8. Equipped with knob that can quickly adjust operating mode, frequency, color code and power.

Functional Features:

1. Supports conventional transceiving in digital / analog modes.
2. Supports PDT/DMR modes.
3. Supports IP networking.
4. Supports pseudo trunking function.
5. Supports simulcast function.
6. Supports trunking function, dynamic frequency, and trunking simulcast.



Note: the above functions may differ among different models, please contact your dealer for details.

Display Icons

Display Icons	Meaning and Status Description
<p>CON/SVC</p>	<p>CON (in yellow)--The channel is control channel. SVC (in green)--The channel is voice channel.</p>
<p>Link</p>	<p>Cable link status: In Green - cable link in smooth connection; In Red - cable link disconnects.</p>
<p>CH X</p>	<p>X stands for the channel number, an even number set up by software.</p>
<p>TEM XX°C</p>	<p>X stands for the temperature of the base station. In normal circumstances, the figure it shows is in Green. When the temperature gets too high, the figure is in Red.</p>
<p>Freq: 180</p>	<p>The current frequency of the base station, calculated from this formula: Frequency = (Frequency — 0 Channel Frequency) ÷ Step Value</p>
<p>Slot1</p>	<p>Communication status of Time Slot 1. In conversation, it shows highlight green; In idle state, it is in gray.</p>
<p>Slot2</p>	<p>Communication statues of Time Slot 2. In conversation, it shows highlight green; In idle state, it is in gray. In analog mode, there is only Time Slot 1, and Time Slot 2 remains in gray.</p>
<p>Rssi: -126 dbm </p>	<p>The green figure represents the received signal strength. The scale below corresponds to the field strength value, the number of red bars displayed represents the field strength, every bar stands for 1 db. The block at the top right of the scale is the received signal indicator. When no signal is received, the LED block indicator is in dark purple; when a time slot is occupied, the LED blinks yellow; when both slots are occupied, the LED lights up solid yellow.</p>



The block at the top right of the scale is the TX power indicator. When the base station is not transmitting, the LED block indicator is in dark purple; when it is transmitting, the LED lights up solid green.

Basic Operations

Installation & Module Inspection

Open the package, check whether all modules are firmly installed in the base station. See Fig. 2 for completion of installation.

To install the modules correctly, you must:

- * Power off the base station before installation.
- * Find the location of modules, take care to their groove direction and the pins inside the base station, and insert the module into the base station in a parallel manner.
- * Tighten the screws on both sides of the module.

Note: There is no screw on both sides of the duplexer module, be sure not to let the back of base station face down, the module may slip off and cause damage to people or the equipment.

Connecting the Feeder and Antenna

After the completion of module installation, you should connect the TX&RX port of the base station and the High&Low ends of the duplexer together with feeders properly.

When the TX frequency of the base station is higher than its RX frequency, the connecting diagram is as follows:

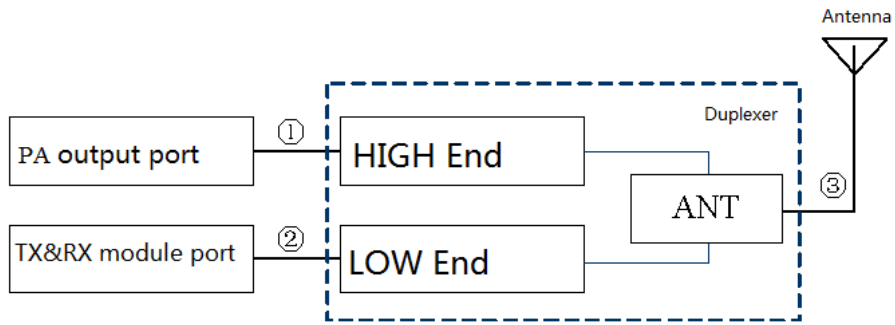

* Connect the corresponding ports with feeders. Connect the antenna at the ANT port, as shown in the diagram below. You need to use three feeders at ①②③ connections.

* Take care to the matchness of the ports, or it may cause damages to the ports. See the completion of the connection in Fig. 3 (only for the case when the TX frequency is higher than the RX frequency).

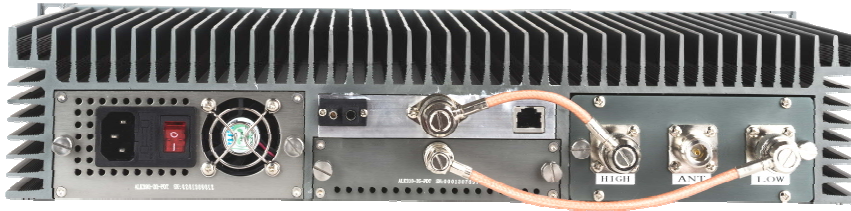

Figure 3-Cabling Diagram

Power on/off

Power on:

- * Connect to 120V AC power supply.
- * Switch on the power supply module, the power indicator lights up red.
- * The cooling fan rotates 1-2 seconds before it stops, and the the display shows channel information.



Note: The moment when the base station is powered on, the cooling fan rotates 1-2 seconds and then stop, so you can see whether the fan works normally.

Power off:

- * Press the power switch at the back of the base station (Fig.2-②), the power indicator goes out.
- * The display shuts down.



Note: Be sure to cut off the power supply completely if the equipment won't be used for a long time. And please keep it in a dry environment free of dust.

Menu Item Operation

Switch Mode

- Press the button, move cursor to Switch Mode item. You can adjust operating modes according to three different combination "Trunk/Convt", " Digital/Analog", "DMR/PDT".
- After moving the cursor to the corresponding item, press "Back" to exit the setting interface and back to the main item; or press "Exit" to go back to

the main interface and enable the new setting.

Setting Mode	Digital/Analog	Trunk/Convrt	PDT/DMR
Analog Conventional	Analog	Convrt	invalid
PDT Conventional	Digital	Convrt	PDT
DMR Conventional	Digital	Convrt	DMR
Analog Trunking	Analog	Trunk	Invalid
PDT Conventional	Digital	Trunk	PDT
DMR Conventional	Digital	Convrt	DMR

Note: Base stations that are under pseudo trunking mode also need to set to DMR conventional. Other settings should be adjusted by software and can only carried out by professionals. Please do not change arbitrarily.

Terminals for conventional calls should satisfy the following conditions for proper functioning:

1. Transmitting and receiving frequency should correspond to the base station.

2. Same color code
3. Subscribers that make calls should be in the same group.

Terminals for trunking calls should satisfy the following conditions for proper functioning:

1. The control channel of the base station is registered.
2. Radio's ID is registered in the base station.
3. Group call is registered or opened in the base station.
4. Color code and systematic code should correspond to the base station.



Note :

1. Under trunking mode, radio can not join the network only by interface changing. Radio ID and group call numbers should first be registered through network management software in the corresponding page.
2. This mode switching function is a purchased function. If user does not pay for it, the function will not be valid. For more information please contact with dealer.

Choose inter Frequency

- Press the knob to enter "Choose inter Freq".
- Transceiver can save 16 inter frequencies, which are available for all operating modes. Num 1~16 stands for inter frequency, while Num 0 stands for the current frequency. If you accidentally enter into this menu

item, please choose the 0 number so that the frequency will not be changed.

Change Frequency

- Press the knob to enter "Change Frequency".
- Firstly, choose that way of frequency. If the Way is "CCM", that means only CCM will control frequency and manual adjustment will not be valid. If you need to adjust, please change the Way to "PC".
- Put the cursor at the frequency frame behind "TX Freq" and press the knob. Start from the highest digit and change the number by rotating the knob. Once finish the highest one then can change the next digit number. If you finish changing the TX frequency, put the cursor to "RX Freq" and change in the same way.

Adjust Power

- Press the knob to enter "Adjust Power".
- The power displayed in the entry page is the current power value. Rotate the knob clockwise to lower down power and anticlockwise to add up



Note :While operating please do not choose "--W" , which is a special item for power standardizing ; If this item is chosen, the power will not be fixed at a certain value, which will affect the function of low power warning.

power.

Adjust Gate

- Press the knob to enter "Adjust Gate"
- Parameters of "RSSI" and "Noise" can be changed. Receiving threshold of base station is decided by both RSSI and noise value. Threshold value can be changed according to the actual environment where base stations are set up. Factory default value of RSSI is -115.

Listen RX Audio

- Press the knob to enter "Listen RX Audio".
- Under analog mode, you can listen to the conversation in the current channel by turning on the Listen RX Audio.



Note :Only under analog mode can a transceiver listen to the conversation.

Change Color Code

- Press the knob and enter "Change Color Code".
- The selectable range of color code is totally 16 values, 0~15. Rotate the knob to choose value and press the knob to validate it and exit.



Note : Color code can only be changed under digital mode. Changes will not be valid under analog mode.

Change System Code

- Press the knob and enter "Change System Code".
- System code consists of four selectable hexadecimal numbers. Start from the highest digit to adjust the value. The adjustment range is "0000~FFFF".



Note : System code can only be changed under trunking mode. Changes will not be valid under conventional mode.

Set CTCSS

- Press the knob and enter "Set CTCSS".
- TX and RX can be changed. If you choose "Forbid", CTCSS will not be valid. By rotating the knob Standard CTCSS is selectable for encryption and anti-interference.



Note :

1. CTCSS can only be set under analog conventional mode.
2. TX CTCSS from base station should be corresponded to the RX CTCSS of the receiving terminal, while the RX CTCSS of base station correspond to the TX CTCSS of the receiving terminal.

Device Message

- Press the knob and enter "Device Message".
- You can check the ESN code, factory date (Date), operating frequency (Freq), program version (CCM,RTM,CLB) and other information of the equipment.

LANGUAGE

- Press the knob and enter "LANGUAGE".
- You can choose Chinese or English. After the adjustment, display language will switch to the language you choose.

Connecting to the PC

For more settings and information about the equipment, please use the software to read and reset.

Here is the illustration of the programming cable. It consists of two cables (①、③), pay attention to different interfaces) and a programming panel (②); After connecting, connect cable ① to the PC with the USB end. If the programming panel (②) lights up red, connection is working. When you are reading data, the other light on panel is flashing green.

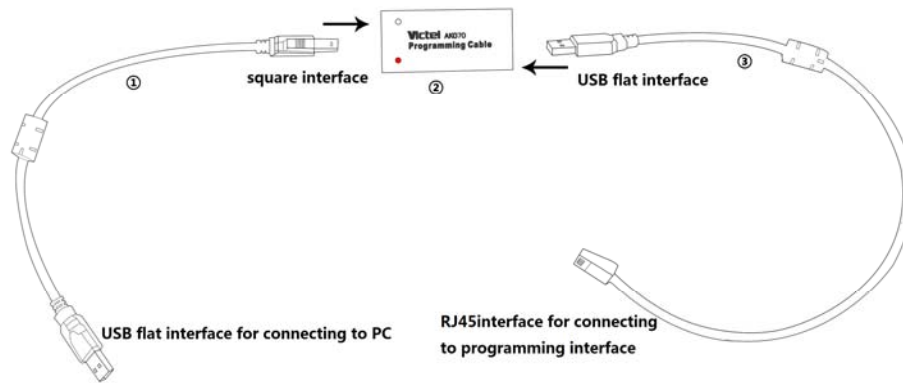

Figure 4-1-Programming cable illustration

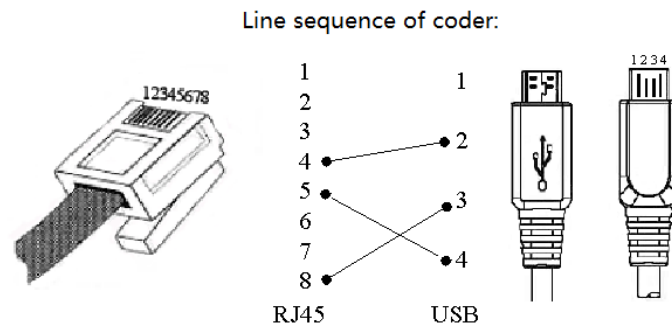

Figure 4-2-Programming cable and line sequence

- * Connect the RJ45 end of the programming cable to the local management port of the base station (as shown in Fig.1-⑦)
- * Connect the other end of the programming cable to the USB port of your computer.
- * Install the software driver, and you can read and set information of the base

station.



Note: For detailed operation guides, refer to the software instruction.

Installation of the Satellite Module

The satellite module and satellite antenna need to be installed before base stations can work as simulcast base stations. Put the antenna at places such as outdoor where it can receive better signals from satellites.

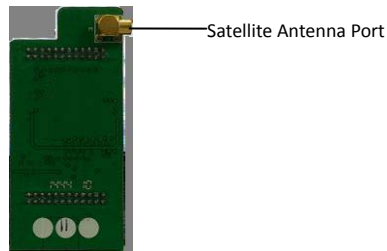

Figure 5-Satellite Module



Figure 6-Satellite Antenna

- * Align the satellite module with the slot and insert it into the base station (see Fig.1-②)
- * Attach the satellite antenna, and put the magnetic block at an outdoor place where it can be exposed to daylight.



Note: 1. In general, the satellite module is installed in factory. No need for users to install.

2. The satellite module is not included in the standard portfolio of some models.

3. Power off the equipment before installation of the satellite module, and do not turn it on until completion of installation.

Parameter Settings

- * All simulcast base stations must be of the same frequency.
- * Simulcast base stations need to connect together through IP or E1 link.

Multi-channel Connection

In a base station, when the number of channels is 2 or more, the channels are connected through cables, as mostly seen in trunking base stations or DMR pseudo trunking.

*Through row cable connection, channels are connected together. The bus slot (Fig.1-④) has two rows, which respectively connect to the upper and lower transceivers.

*Base station controller is generally used in multi-channel connection.

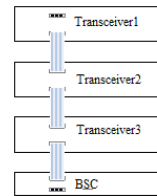



Figure 7-Row Cable

Channel Connection Diagram

Dip Switch & Channel Number Settings

The settings of dip switch (see Fig.1-③) should be corresponding to the settings of channel number of the network management terminal (see software instructions for details). As for a single carrier channel, the corresponding method can be summarized in this formula: channel number = Dip number * 2-2. The dip number can be set according to the corresponding channel position.

S.N.	Dip switch	Channel No.
Base station 1	1	0
Base station 2	2	2
Base station 3	3	4

 Note: 1. Dip switches are in pairs (upper and lower), both need to be switched to ON!
 2. Channel number should be even number, wrong settings may cause malfunction of base station!

IP Networking

In a multi-channel network, portable radios in different channels can communicate with each other.

* Connect the IP port of base station (Fig.2-⑥) to the port of switch with a standard network cable.

* Set the IP of the local base station, and register the IPs of base stations of the network. As shown in the diagram, in Base station1, you need to register the IPs of Base station2 and Base station3. Such operations need to be done via software, see details in the software instruction.

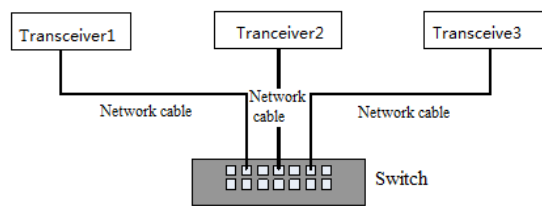

Diagram of IP Connection

Alarm Message

All alarms are shown in the display. When an operation parameter exceeds the preset value, it will be displayed in RED as a warning.

1. Cable Link Disconnect

When a cable link is disconnected, it is displayed in the Red icon【Link】: indicating cable link has been disconnected, please check the cable and settings.

2. Forward Power too Low

When you have set the minimum power via the software, the base station will automatically adjust the TX frequency, which must be higher than the minimum power. When the base station fails to reach this frequency, however, the display will show the alarm. For example, the minimum power is set at 5W, while the base station can only operate at 5W currently, the alarm is shown as 【pow: 5W】.

3. High Temperature Alarm

When the working temperature of base station is higher than the value set via software, it will show the high temperature alarm. For example, the high temperature threshold is set at 70℃, when the temperature of base station is

75℃, the temperature is displayed as 【^{TEM}75℃】. You need to move the base station to a dry and cool place to facilitate dissipation. Or shut down the power, and terminate its operation at high power.

4. High Reflection Alarm

When the reverse power is greater than the power set via software, it will show the high reflective warning icon 【Pow: 20W 0.0】. You need to check the feeder connecting to the power amplifier port, the frequency band of duplexer, and the matchness of antenna, etc.

Performance Specifications

Basic Operating Parameters	
Operating Frequency Range	400-470MHz
Channel Space	12.5kHz
Multi-Access Method	TDMA
Duplex Spacing	5M~10MHz
Modulation and Demodulation	4FSK/FM
Successive Data Speed (per carrier)	9.6kbps
Carrier Frequency Error	≤100Hz
Operating Humidity	20% ~ 80%
Storage Humidity	< 80%
Operating Temperature	-30°C ~ 60°C
Storage Temperature	-40°C ~ 85°C

Receiver		
Sensitivity (5%BER)(Digital)	Static Sensitivity	-120dBm
	Dynamic sensitivity	-115dBm
Sensitivity (12dB SINAD) (Analog)		-115dBm
Maximum Signal Rx Level		-7dBm
Adjacent Channel Selectivity		-65dB@12.5KHz/ -70dB@25KHz

Co-channel Rejection	12dB
Blocking	84dB
Inter-modulation	70dB
Spurious Response Rejection	70dB
Conducted Spurious Emission	-57dBm

Transmitter	
Frequency Stability	±0.1 ppm
RF Output Power	50W/5W
Maximum Output Power Tolerance	±1.5dB (Normal) /+2/-3dB (Extreme)
Adjacent Channel Power	-65dB@12.5KHz / -75dB@25KHz
Conducted/Radiated Interference (Antenna, transmit mode)	9kHz~1GHz≤-36dBm 1GHz~12.75GHz≤-30dBm
Conducted/Radiated Interference (Antenna, standby mode)	30MHz~1GHz≤-36dBm 1GHz~12.75GHz≤-30dBm
Inter-modulation attenuation	≤-60dB@12.5KHz ≤-70dB@25KHz
Transient Switch ACPR	±12.5kHz≤-50dB ±25kHz≤-60dB

Troubleshooting

Problem	Possible causes	Solution
Power is on but nothing appears on LED.	1.Poor connection	Check whether the base station is connected properly to 120V AC power supply.
	2.The power supply module is broken.	Check the voltage of the power supply module with a multimeter.
Transmission is not possible.	1. TX & RX frequencies of radio are non-corresponding with that of the base station.	Check whether the TX & RX frequencies are corresponding. Reset them if necessary.
	2. Under strong interference	Find out and move away from the interference source. Ensure the desired signal is 12 dBm over the background noise.
	3.The radio may not detect signals from the base station.	Make sure you are within the coverage of the base station. And test again.
Short communication distance	1.There may be physical barriers.	Move to an open, flat area and test communication. Or fix the antenna at a higher position.
	2.The power is set too low.	Check the power setting of the base station, raise the power accordingly.
	3.The radio antenna	Tighten the antenna joint of portable radio.

	may get loose.	
	4. Background noise	Check whether there is any interference. When there is no on-going call, check the background noise.
The voice is unclear.	1. Weak signal	Check the field strength value, you may be on the edge of coverage.
	2. There may be some interference.	Use another frequency and see whether you hear clearer voice.
	3. Background noise too high.	Adjust the RSSI threshold to filter undesired signals. Ensure your desired signal is 12dBm above the RSSI threshold.

Care and Cleaning

To guarantee optimal performance of the base station, and prolong its service life, please read the following advice carefully for guidance on daily care and cleaning of the product.

- Care

To facilitate good ventilation and emergency maintenance, allow about 10cm access between the base station and the surrounding walls.

- Do not place anything which might spill over on top of the base station.
- Do not puncture or scratch the base station surface with hard, sharp objects.
- Do not store the base station in environment with corrosive electronic circuit materials.
- Do not immerse the base station into corrosive agent, solution or water.

- Cleaning

- De-dust components of the base station regularly with clean and dry lint free cloth or brush, in order to maintain their cleanness and avoid bad contact.
- When the power key, control knob, display screen and interfaces get dirty, clean them with a non-woven cloth soaking with neutral detergent. Do not use strong corrosive chemical solution, for instance, detergent, alcohol, spray agent or oil preparation, for cleaning.

After cleaning, make sure the base station is completely dry, otherwise do not operate it.

The maximum allowable station effective radiated power (ERP) is dependent upon the station's antenna HAAT and required service area and will be authorized in accordance with table 2.

TABLE 2—450-470 MHz—MAXIMUM ERP/REFERENCE HAAT FOR A SPECIFIC SERVICE AREA RADIUS

	Service area radius (km)										
	3	8	13	16	24	32	40 ⁴	48 ⁴	64 ⁴	80 ⁴	
Maximum ERP (w) ¹	2	100	2500	2500	2500	2500	2500	2500	2500	2500	2500
Up to reference HAAT (m) ³	15	15	15	27	63	125	250	410	950	2700	

Operational Instructions and Training Guidelines

To ensure optimal performance and compliance with the General Population/Uncontrolled environment RF energy exposure limits in the above standards and guidelines, users should transmit not more than 100% of the time and always adhere to the following procedures:

- Antenna gain must not exceed 8.0dBi.
- The antenna must be installed complying with the requirements of manufacturer or supplier, and it must be at least 3.5 meters away from human body.
- The device’s antenna must be fixed mounted on outdoor permanent structures.

SHENZHEN SAMHOO SCI & TECH CO.,LTD.

Samhoo

is registered trademark of SHENZHEN SAMHOO SCI & TECH CO.,LTD.
and is under authorized use.

© Copyright 2013 SHENZHEN SAMHOO SCI & TECH CO.,LTD.
All rights reserved.

SHENZHEN SAMHOO SCI & TECH CO.,LTD.

Add: Room 401, Building 2, Huaqiangyun Industrial Park, Meixiu Road,
Mellin, Futian District, Shenzhen, China.

Tel: +86 755 8316 0260 **Fax:** +86 755 8316 3773

E-mail: sales@samhoo.com.cn

Web: www.samhoo-pmr.com

