



Product Name	Panel PC	Test By	Audi Chang
Test Model	VM-521	Test Date	2014/11/19
Test Mode	UNII Band 2A / IEEE 802.11ac VHT20 TX / CH High / External Antenna	Temp. & Humidity	25°C, 50%

966 Chamber_B at 3Meter / Horizontal									
Frequency (MHz)	Reading-PK (dBuV)	Reading-AV (dBuV)	Correction Factor (dB/m)	Result-PK (dBuV/m)	Result-AV (dBuV/m)	Limit-PK (dBuV/m)	Limit-AV (dBuV/m)	Margin (dB)	Remark
1795.00	46.91	---	0.73	47.64	---	74.00	54.00	-6.36	Peak
2535.00	42.63	---	3.69	46.32	---	74.00	54.00	-7.68	Peak
4125.00	40.94	---	6.97	47.91	---	74.00	54.00	-6.09	Peak
6120.00	38.42	---	12.72	51.14	---	74.00	54.00	-2.86	Peak
6924.00	38.51	---	13.84	52.35	---	74.00	54.00	-1.65	Peak
8352.00	37.44	---	15.14	52.57	---	74.00	54.00	-1.43	Peak

966 Chamber_B at 3Meter / Vertical									
Frequency (MHz)	Reading-PK (dBuV)	Reading-AV (dBuV)	Correction Factor (dB/m)	Result-PK (dBuV/m)	Result-AV (dBuV/m)	Limit-PK (dBuV/m)	Limit-AV (dBuV/m)	Margin (dB)	Remark
2350.00	41.85	---	3.32	45.17	---	74.00	54.00	-8.83	Peak
3255.00	42.40	---	5.22	47.62	---	74.00	54.00	-6.38	Peak
4585.00	40.90	---	8.81	49.71	---	74.00	54.00	-4.29	Peak
6156.00	38.91	---	12.70	51.61	---	74.00	54.00	-2.39	Peak
7140.00	38.63	---	13.70	52.33	---	74.00	54.00	-1.67	Peak
8436.00	37.05	---	15.36	52.41	---	74.00	54.00	-1.59	Peak

Remark:

1. Measuring frequencies from 1 GHz to the 10th harmonic of highest fundamental frequency.
2. Average test would be performed if the peak result were greater than the average limit.
3. Data of measurement within this frequency range shown " --- " in the table above means the reading of emissions are attenuated more than 20dB below the permissible limits or the field strength is too small to be measured.
4. Measurements above show only up to 6 maximum emissions noted, or would be lesser, with " N/A " remark, if no specific emissions from the EUT are recorded (ie: margin>20dB from the applicable limit) and considered that's already beyond the background noise floor.
5. Result = Reading + Correction Factor
Margin = Result - Limit
Remark Peak = Result(PK) - Limit(AV)
Remark AVG = Result(AV) - Limit(AV)



Product Name	Panel PC	Test By	Audi Chang
Test Model	VM-521	Test Date	2014/11/19
Test Mode	UNII Band 2A / IEEE 802.11ac VHT40 TX / CH Low / External Antenna	Temp. & Humidity	25°C, 50%

966 Chamber_B at 3Meter / Horizontal									
Frequency (MHz)	Reading-PK (dBuV)	Reading-AV (dBuV)	Correction Factor (dB/m)	Result-PK (dBuV/m)	Result-AV (dBuV/m)	Limit-PK (dBuV/m)	Limit-AV (dBuV/m)	Margin (dB)	Remark
1795.00	46.14	---	0.73	46.87	---	74.00	54.00	-7.13	Peak
3290.00	41.51	---	5.28	46.79	---	74.00	54.00	-7.21	Peak
4585.00	41.38	---	8.81	50.19	---	74.00	54.00	-3.81	Peak
6084.00	39.19	---	12.73	51.92	---	74.00	54.00	-2.08	Peak
6780.00	38.66	---	13.40	52.06	---	74.00	54.00	-1.94	Peak
8040.00	37.63	---	14.31	51.93	---	74.00	54.00	-2.07	Peak

966 Chamber_B at 3Meter / Vertical									
Frequency (MHz)	Reading-PK (dBuV)	Reading-AV (dBuV)	Correction Factor (dB/m)	Result-PK (dBuV/m)	Result-AV (dBuV/m)	Limit-PK (dBuV/m)	Limit-AV (dBuV/m)	Margin (dB)	Remark
2480.00	42.19	---	3.57	45.76	---	74.00	54.00	-8.24	Peak
3220.00	43.30	---	5.16	48.46	---	74.00	54.00	-5.54	Peak
3775.00	42.68	---	6.03	48.71	---	74.00	54.00	-5.29	Peak
6060.00	38.93	---	12.74	51.67	---	74.00	54.00	-2.33	Peak
7164.00	38.71	---	13.64	52.35	---	74.00	54.00	-1.65	Peak
8220.00	37.81	---	14.79	52.60	---	74.00	54.00	-1.40	Peak

Remark:

1. Measuring frequencies from 1 GHz to the 10th harmonic of highest fundamental frequency.
2. Average test would be performed if the peak result were greater than the average limit.
3. Data of measurement within this frequency range shown " --- " in the table above means the reading of emissions are attenuated more than 20dB below the permissible limits or the field strength is too small to be measured.
4. Measurements above show only up to 6 maximum emissions noted, or would be lesser, with " N/A " remark, if no specific emissions from the EUT are recorded (ie: margin>20dB from the applicable limit) and considered that's already beyond the background noise floor.
5. Result = Reading + Correction Factor
Margin = Result - Limit
Remark Peak = Result(PK) - Limit(AV)
Remark AVG = Result(AV) - Limit(AV)



Product Name	Panel PC	Test By	Audi Chang
Test Model	VM-521	Test Date	2014/11/19
Test Mode	UNII Band 2A / IEEE 802.11ac VHT40 TX / CH High / External Antenna	Temp. & Humidity	25°C, 50%

966 Chamber_B at 3Meter / Horizontal									
Frequency (MHz)	Reading-PK (dBuV)	Reading-AV (dBuV)	Correction Factor (dB/m)	Result-PK (dBuV/m)	Result-AV (dBuV/m)	Limit-PK (dBuV/m)	Limit-AV (dBuV/m)	Margin (dB)	Remark
1835.00	44.30	---	1.10	45.40	---	74.00	54.00	-8.60	Peak
3265.00	42.67	---	5.24	47.90	---	74.00	54.00	-6.10	Peak
3975.00	40.79	---	6.31	47.11	---	74.00	54.00	-6.89	Peak
6120.00	38.97	---	12.72	51.68	---	74.00	54.00	-2.32	Peak
6900.00	38.78	---	13.77	52.54	---	74.00	54.00	-1.46	Peak
8136.00	37.35	---	14.56	51.92	---	74.00	54.00	-2.08	Peak

966 Chamber_B at 3Meter / Vertical									
Frequency (MHz)	Reading-PK (dBuV)	Reading-AV (dBuV)	Correction Factor (dB/m)	Result-PK (dBuV/m)	Result-AV (dBuV/m)	Limit-PK (dBuV/m)	Limit-AV (dBuV/m)	Margin (dB)	Remark
1965.00	43.22	---	2.31	45.52	---	74.00	54.00	-8.48	Peak
3425.00	42.06	---	5.50	47.56	---	74.00	54.00	-6.44	Peak
3875.00	41.48	---	6.17	47.65	---	74.00	54.00	-6.35	Peak
6120.00	38.80	---	12.72	51.51	---	74.00	54.00	-2.49	Peak
6888.00	38.77	---	13.73	52.50	---	74.00	54.00	-1.50	Peak
7980.00	38.27	---	14.14	52.41	---	74.00	54.00	-1.59	Peak

Remark:

1. Measuring frequencies from 1 GHz to the 10th harmonic of highest fundamental frequency.
2. Average test would be performed if the peak result were greater than the average limit.
3. Data of measurement within this frequency range shown " --- " in the table above means the reading of emissions are attenuated more than 20dB below the permissible limits or the field strength is too small to be measured.
4. Measurements above show only up to 6 maximum emissions noted, or would be lesser, with " N/A " remark, if no specific emissions from the EUT are recorded (ie: margin>20dB from the applicable limit) and considered that's already beyond the background noise floor.
5. Result = Reading + Correction Factor
Margin = Result - Limit
Remark Peak = Result(PK) - Limit(AV)
Remark AVG = Result(AV) - Limit(AV)



Product Name	Panel PC	Test By	Audi Chang
Test Model	VM-521	Test Date	2014/11/19
Test Mode	UNII Band 2A / IEEE 802.11ac VHT80 TX / CH Low / External Antenna	Temp. & Humidity	25°C, 50%

966 Chamber_B at 3Meter / Horizontal									
Frequency (MHz)	Reading-PK (dBuV)	Reading-AV (dBuV)	Correction Factor (dB/m)	Result-PK (dBuV/m)	Result-AV (dBuV/m)	Limit-PK (dBuV/m)	Limit-AV (dBuV/m)	Margin (dB)	Remark
1715.00	47.15	---	-0.01	47.13	---	74.00	54.00	-6.87	Peak
3210.00	42.09	---	5.14	47.24	---	74.00	54.00	-6.76	Peak
4425.00	40.25	---	8.48	48.73	---	74.00	54.00	-5.27	Peak
6096.00	38.40	---	12.73	51.13	---	74.00	54.00	-2.87	Peak
7836.00	38.40	---	13.72	52.12	---	74.00	54.00	-1.88	Peak
9036.00	36.32	---	15.21	51.53	---	74.00	54.00	-2.47	Peak

966 Chamber_B at 3Meter / Vertical									
Frequency (MHz)	Reading-PK (dBuV)	Reading-AV (dBuV)	Correction Factor (dB/m)	Result-PK (dBuV/m)	Result-AV (dBuV/m)	Limit-PK (dBuV/m)	Limit-AV (dBuV/m)	Margin (dB)	Remark
2525.00	42.51	---	3.67	46.18	---	74.00	54.00	-7.82	Peak
3185.00	42.21	---	5.10	47.31	---	74.00	54.00	-6.69	Peak
4580.00	39.95	---	8.81	48.76	---	74.00	54.00	-5.24	Peak
6192.00	39.11	---	12.69	51.80	---	74.00	54.00	-2.20	Peak
7188.00	38.90	---	13.57	52.47	---	74.00	54.00	-1.53	Peak
7872.00	38.54	---	13.83	52.37	---	74.00	54.00	-1.63	Peak

Remark:

1. Measuring frequencies from 1 GHz to the 10th harmonic of highest fundamental frequency.
2. Average test would be performed if the peak result were greater than the average limit.
3. Data of measurement within this frequency range shown " --- " in the table above means the reading of emissions are attenuated more than 20dB below the permissible limits or the field strength is too small to be measured.
4. Measurements above show only up to 6 maximum emissions noted, or would be lesser, with " N/A " remark, if no specific emissions from the EUT are recorded (ie: margin>20dB from the applicable limit) and considered that's already beyond the background noise floor.
5. Result = Reading + Correction Factor
Margin = Result - Limit
Remark Peak = Result(PK) - Limit(AV)
Remark AVG = Result(AV) - Limit(AV)



Product Name	Panel PC	Test By	Audi Chang
Test Model	VM-521	Test Date	2014/11/19
Test Mode	UNII Band 2C / IEEE 802.11a TX / CH Low / External Antenna	Temp. & Humidity	25°C, 50%

966 Chamber_B at 3Meter / Horizontal									
Frequency (MHz)	Reading-PK (dBuV)	Reading-AV (dBuV)	Correction Factor (dB/m)	Result-PK (dBuV/m)	Result-AV (dBuV/m)	Limit-PK (dBuV/m)	Limit-AV (dBuV/m)	Margin (dB)	Remark
1715.00	48.31	---	-0.01	48.30	---	74.00	54.00	-5.70	Peak
1915.00	46.25	---	1.84	48.09	---	74.00	54.00	-5.91	Peak
4565.00	41.21	---	8.82	50.03	---	74.00	54.00	-3.97	Peak
6048.00	37.54	---	12.75	50.29	---	74.00	54.00	-3.71	Peak
7800.00	37.65	---	13.62	51.27	---	74.00	54.00	-2.73	Peak
8880.00	37.04	---	15.24	52.28	---	74.00	54.00	-1.72	Peak

966 Chamber_B at 3Meter / Vertical									
Frequency (MHz)	Reading-PK (dBuV)	Reading-AV (dBuV)	Correction Factor (dB/m)	Result-PK (dBuV/m)	Result-AV (dBuV/m)	Limit-PK (dBuV/m)	Limit-AV (dBuV/m)	Margin (dB)	Remark
3145.00	41.96	---	5.03	46.99	---	74.00	54.00	-7.01	Peak
4700.00	39.29	---	8.75	48.04	---	74.00	54.00	-5.96	Peak
5975.00	36.53	---	12.66	49.20	---	74.00	54.00	-4.80	Peak
6132.00	38.15	---	12.71	50.87	---	74.00	54.00	-3.13	Peak
7404.00	38.19	---	13.00	51.19	---	74.00	54.00	-2.81	Peak
9180.00	36.50	---	15.44	51.94	---	74.00	54.00	-2.06	Peak

Remark:

1. Measuring frequencies from 1 GHz to the 10th harmonic of highest fundamental frequency.
2. Average test would be performed if the peak result were greater than the average limit.
3. Data of measurement within this frequency range shown " --- " in the table above means the reading of emissions are attenuated more than 20dB below the permissible limits or the field strength is too small to be measured.
4. Measurements above show only up to 6 maximum emissions noted, or would be lesser, with " N/A " remark, if no specific emissions from the EUT are recorded (ie: margin>20dB from the applicable limit) and considered that's already beyond the background noise floor.
5. Result = Reading + Correction Factor
Margin = Result - Limit
Remark Peak = Result(PK) - Limit(AV)
Remark AVG = Result(AV) - Limit(AV)



Product Name	Panel PC	Test By	Audi Chang
Test Model	VM-521	Test Date	2014/11/19
Test Mode	UNII Band 2C / IEEE 802.11a TX / CH Middle / External Antenna	Temp. & Humidity	25°C, 50%

966 Chamber_B at 3Meter / Horizontal									
Frequency (MHz)	Reading-PK (dBuV)	Reading-AV (dBuV)	Correction Factor (dB/m)	Result-PK (dBuV/m)	Result-AV (dBuV/m)	Limit-PK (dBuV/m)	Limit-AV (dBuV/m)	Margin (dB)	Remark
1665.00	45.63	---	-0.48	45.15	---	74.00	54.00	-8.85	Peak
2530.00	41.69	---	3.68	45.38	---	74.00	54.00	-8.62	Peak
3135.00	42.29	---	5.02	47.31	---	74.00	54.00	-6.69	Peak
6048.00	38.12	---	12.75	50.87	---	74.00	54.00	-3.13	Peak
6948.00	38.41	---	13.91	52.32	---	74.00	54.00	-1.68	Peak
8244.00	37.16	---	14.85	52.01	---	74.00	54.00	-1.99	Peak

966 Chamber_B at 3Meter / Vertical									
Frequency (MHz)	Reading-PK (dBuV)	Reading-AV (dBuV)	Correction Factor (dB/m)	Result-PK (dBuV/m)	Result-AV (dBuV/m)	Limit-PK (dBuV/m)	Limit-AV (dBuV/m)	Margin (dB)	Remark
1985.00	41.93	---	2.49	44.42	---	74.00	54.00	-9.58	Peak
2900.00	42.06	---	4.55	46.61	---	74.00	54.00	-7.39	Peak
4655.00	40.81	---	8.78	49.59	---	74.00	54.00	-4.41	Peak
6024.00	38.03	---	12.76	50.79	---	74.00	54.00	-3.21	Peak
7800.00	37.65	---	13.62	51.27	---	74.00	54.00	-2.73	Peak
9084.00	36.79	---	15.29	52.07	---	74.00	54.00	-1.93	Peak

Remark:

1. Measuring frequencies from 1 GHz to the 10th harmonic of highest fundamental frequency.
2. Average test would be performed if the peak result were greater than the average limit.
3. Data of measurement within this frequency range shown " --- " in the table above means the reading of emissions are attenuated more than 20dB below the permissible limits or the field strength is too small to be measured.
4. Measurements above show only up to 6 maximum emissions noted, or would be lesser, with " N/A " remark, if no specific emissions from the EUT are recorded (ie: margin>20dB from the applicable limit) and considered that's already beyond the background noise floor.
5. Result = Reading + Correction Factor
Margin = Result - Limit
Remark Peak = Result(PK) - Limit(AV)
Remark AVG = Result(AV) - Limit(AV)



Product Name	Panel PC	Test By	Audi Chang
Test Model	VM-521	Test Date	2014/11/19
Test Mode	UNII Band 2C / IEEE 802.11a TX / CH High / External Antenna	Temp. & Humidity	25°C, 50%

966 Chamber_B at 3Meter / Horizontal									
Frequency (MHz)	Reading-PK (dBuV)	Reading-AV (dBuV)	Correction Factor (dB/m)	Result-PK (dBuV/m)	Result-AV (dBuV/m)	Limit-PK (dBuV/m)	Limit-AV (dBuV/m)	Margin (dB)	Remark
1705.00	45.64	---	-0.11	45.53	---	74.00	54.00	-8.47	Peak
2605.00	41.77	---	3.86	45.62	---	74.00	54.00	-8.38	Peak
3830.00	42.06	---	6.11	48.16	---	74.00	54.00	-5.84	Peak
6216.00	38.37	---	12.67	51.05	---	74.00	54.00	-2.95	Peak
7704.00	38.12	---	13.34	51.47	---	74.00	54.00	-2.53	Peak
8916.00	37.07	---	15.21	52.29	---	74.00	54.00	-1.71	Peak

966 Chamber_B at 3Meter / Vertical									
Frequency (MHz)	Reading-PK (dBuV)	Reading-AV (dBuV)	Correction Factor (dB/m)	Result-PK (dBuV/m)	Result-AV (dBuV/m)	Limit-PK (dBuV/m)	Limit-AV (dBuV/m)	Margin (dB)	Remark
2050.00	41.98	---	2.73	44.70	---	74.00	54.00	-9.30	Peak
2560.00	41.85	---	3.75	45.60	---	74.00	54.00	-8.40	Peak
4495.00	40.70	---	8.83	49.53	---	74.00	54.00	-4.47	Peak
6204.00	38.86	---	12.68	51.54	---	74.00	54.00	-2.46	Peak
7464.00	38.95	---	12.85	51.80	---	74.00	54.00	-2.20	Peak
8304.00	37.40	---	15.01	52.40	---	74.00	54.00	-1.60	Peak

Remark:

1. Measuring frequencies from 1 GHz to the 10th harmonic of highest fundamental frequency.
2. Average test would be performed if the peak result were greater than the average limit.
3. Data of measurement within this frequency range shown " --- " in the table above means the reading of emissions are attenuated more than 20dB below the permissible limits or the field strength is too small to be measured.
4. Measurements above show only up to 6 maximum emissions noted, or would be lesser, with " N/A " remark, if no specific emissions from the EUT are recorded (ie: margin>20dB from the applicable limit) and considered that's already beyond the background noise floor.
5. Result = Reading + Correction Factor
Margin = Result - Limit
Remark Peak = Result(PK) - Limit(AV)
Remark AVG = Result(AV) - Limit(AV)



Product Name	Panel PC	Test By	Audi Chang
Test Model	VM-521	Test Date	2014/11/19
Test Mode	UNII Band 2C / IEEE 802.11ac VHT20 TX / CH Low / External Antenna	Temp. & Humidity	25°C, 50%

966 Chamber_B at 3Meter / Horizontal									
Frequency (MHz)	Reading-PK (dBuV)	Reading-AV (dBuV)	Correction Factor (dB/m)	Result-PK (dBuV/m)	Result-AV (dBuV/m)	Limit-PK (dBuV/m)	Limit-AV (dBuV/m)	Margin (dB)	Remark
1715.00	45.74	---	-0.01	45.72	---	74.00	54.00	-8.28	Peak
3860.00	41.76	---	6.15	47.91	---	74.00	54.00	-6.09	Peak
4620.00	41.17	---	8.79	49.97	---	74.00	54.00	-4.03	Peak
6228.00	38.03	---	12.67	50.70	---	74.00	54.00	-3.30	Peak
7356.00	38.04	---	13.13	51.17	---	74.00	54.00	-2.83	Peak
8160.00	37.56	---	14.63	52.19	---	74.00	54.00	-1.81	Peak

966 Chamber_B at 3Meter / Vertical									
Frequency (MHz)	Reading-PK (dBuV)	Reading-AV (dBuV)	Correction Factor (dB/m)	Result-PK (dBuV/m)	Result-AV (dBuV/m)	Limit-PK (dBuV/m)	Limit-AV (dBuV/m)	Margin (dB)	Remark
2190.00	41.80	---	3.00	44.80	---	74.00	54.00	-9.20	Peak
3125.00	42.13	---	5.00	47.13	---	74.00	54.00	-6.87	Peak
4660.00	40.82	---	8.77	49.60	---	74.00	54.00	-4.40	Peak
6144.00	38.55	---	12.71	51.26	---	74.00	54.00	-2.74	Peak
7308.00	37.92	---	13.26	51.18	---	74.00	54.00	-2.82	Peak
8400.00	37.12	---	15.26	52.39	---	74.00	54.00	-1.61	Peak

Remark:

1. Measuring frequencies from 1 GHz to the 10th harmonic of highest fundamental frequency.
2. Average test would be performed if the peak result were greater than the average limit.
3. Data of measurement within this frequency range shown " --- " in the table above means the reading of emissions are attenuated more than 20dB below the permissible limits or the field strength is too small to be measured.
4. Measurements above show only up to 6 maximum emissions noted, or would be lesser, with " N/A " remark, if no specific emissions from the EUT are recorded (ie: margin>20dB from the applicable limit) and considered that's already beyond the background noise floor.
5. Result = Reading + Correction Factor
Margin = Result - Limit
Remark Peak = Result(PK) - Limit(AV)
Remark AVG = Result(AV) - Limit(AV)



Product Name	Panel PC	Test By	Audi Chang
Test Model	VM-521	Test Date	2014/11/19
Test Mode	UNII Band 2C / IEEE 802.11ac VHT20 TX / CH Middle / External Antenna	Temp. & Humidity	25°C, 50%

966 Chamber_B at 3Meter / Horizontal									
Frequency (MHz)	Reading-PK (dBuV)	Reading-AV (dBuV)	Correction Factor (dB/m)	Result-PK (dBuV/m)	Result-AV (dBuV/m)	Limit-PK (dBuV/m)	Limit-AV (dBuV/m)	Margin (dB)	Remark
1650.00	47.39	---	-0.62	46.77	---	74.00	54.00	-7.23	Peak
1850.00	45.23	---	1.24	46.47	---	74.00	54.00	-7.53	Peak
2690.00	42.96	---	4.06	47.02	---	74.00	54.00	-6.98	Peak
6060.00	38.72	---	12.74	51.47	---	74.00	54.00	-2.53	Peak
7716.00	38.44	---	13.38	51.82	---	74.00	54.00	-2.18	Peak
8928.00	37.34	---	15.20	52.54	---	74.00	54.00	-1.46	Peak

966 Chamber_B at 3Meter / Vertical									
Frequency (MHz)	Reading-PK (dBuV)	Reading-AV (dBuV)	Correction Factor (dB/m)	Result-PK (dBuV/m)	Result-AV (dBuV/m)	Limit-PK (dBuV/m)	Limit-AV (dBuV/m)	Margin (dB)	Remark
2025.00	42.16	---	2.68	44.84	---	74.00	54.00	-9.16	Peak
3070.00	42.27	---	4.91	47.18	---	74.00	54.00	-6.82	Peak
3845.00	41.24	---	6.13	47.37	---	74.00	54.00	-6.63	Peak
6084.00	38.00	---	12.73	50.73	---	74.00	54.00	-3.27	Peak
7380.00	38.13	---	13.07	51.20	---	74.00	54.00	-2.80	Peak
8244.00	37.05	---	14.85	51.90	---	74.00	54.00	-2.10	Peak

Remark:

1. Measuring frequencies from 1 GHz to the 10th harmonic of highest fundamental frequency.
2. Average test would be performed if the peak result were greater than the average limit.
3. Data of measurement within this frequency range shown " --- " in the table above means the reading of emissions are attenuated more than 20dB below the permissible limits or the field strength is too small to be measured.
4. Measurements above show only up to 6 maximum emissions noted, or would be lesser, with " N/A " remark, if no specific emissions from the EUT are recorded (ie: margin>20dB from the applicable limit) and considered that's already beyond the background noise floor.
5. Result = Reading + Correction Factor
Margin = Result - Limit
Remark Peak = Result(PK) - Limit(AV)
Remark AVG = Result(AV) - Limit(AV)



Product Name	Panel PC	Test By	Audi Chang
Test Model	VM-521	Test Date	2014/11/19
Test Mode	UNII Band 2C / IEEE 802.11ac VHT20 TX / CH High / External Antenna	Temp. & Humidity	25°C, 50%

966 Chamber_B at 3Meter / Horizontal									
Frequency (MHz)	Reading-PK (dBuV)	Reading-AV (dBuV)	Correction Factor (dB/m)	Result-PK (dBuV/m)	Result-AV (dBuV/m)	Limit-PK (dBuV/m)	Limit-AV (dBuV/m)	Margin (dB)	Remark
1715.00	45.33	---	-0.01	45.31	---	74.00	54.00	-8.69	Peak
3110.00	42.71	---	4.97	47.69	---	74.00	54.00	-6.31	Peak
4675.00	40.49	---	8.77	49.25	---	74.00	54.00	-4.75	Peak
6120.00	38.40	---	12.72	51.12	---	74.00	54.00	-2.88	Peak
7176.00	38.17	---	13.61	51.77	---	74.00	54.00	-2.23	Peak
8292.00	36.68	---	14.98	51.66	---	74.00	54.00	-2.34	Peak

966 Chamber_B at 3Meter / Vertical									
Frequency (MHz)	Reading-PK (dBuV)	Reading-AV (dBuV)	Correction Factor (dB/m)	Result-PK (dBuV/m)	Result-AV (dBuV/m)	Limit-PK (dBuV/m)	Limit-AV (dBuV/m)	Margin (dB)	Remark
2775.00	42.08	---	4.26	46.34	---	74.00	54.00	-7.66	Peak
3830.00	41.26	---	6.11	47.37	---	74.00	54.00	-6.63	Peak
4410.00	40.06	---	8.40	48.46	---	74.00	54.00	-5.54	Peak
6132.00	38.08	---	12.71	50.79	---	74.00	54.00	-3.21	Peak
7728.00	37.88	---	13.41	51.29	---	74.00	54.00	-2.71	Peak
8916.00	35.99	---	15.21	51.20	---	74.00	54.00	-2.80	Peak

Remark:

1. Measuring frequencies from 1 GHz to the 10th harmonic of highest fundamental frequency.
2. Average test would be performed if the peak result were greater than the average limit.
3. Data of measurement within this frequency range shown " --- " in the table above means the reading of emissions are attenuated more than 20dB below the permissible limits or the field strength is too small to be measured.
4. Measurements above show only up to 6 maximum emissions noted, or would be lesser, with " N/A " remark, if no specific emissions from the EUT are recorded (ie: margin>20dB from the applicable limit) and considered that's already beyond the background noise floor.
5. Result = Reading + Correction Factor
Margin = Result - Limit
Remark Peak = Result(PK) - Limit(AV)
Remark AVG = Result(AV) - Limit(AV)



Product Name	Panel PC	Test By	Audi Chang
Test Model	VM-521	Test Date	2014/11/19
Test Mode	UNII Band 2C / IEEE 802.11ac VHT40 TX / CH Low / External Antenna	Temp. & Humidity	25°C, 50%

966 Chamber_B at 3Meter / Horizontal									
Frequency (MHz)	Reading-PK (dBuV)	Reading-AV (dBuV)	Correction Factor (dB/m)	Result-PK (dBuV/m)	Result-AV (dBuV/m)	Limit-PK (dBuV/m)	Limit-AV (dBuV/m)	Margin (dB)	Remark
1785.00	48.51	---	0.63	49.14	---	74.00	54.00	-4.86	Peak
3920.00	41.74	---	6.23	47.98	---	74.00	54.00	-6.02	Peak
4255.00	40.30	---	7.62	47.93	---	74.00	54.00	-6.07	Peak
6216.00	38.22	---	12.67	50.89	---	74.00	54.00	-3.11	Peak
7692.00	37.59	---	13.31	50.90	---	74.00	54.00	-3.10	Peak
8964.00	36.06	---	15.18	51.24	---	74.00	54.00	-2.76	Peak

966 Chamber_B at 3Meter / Vertical									
Frequency (MHz)	Reading-PK (dBuV)	Reading-AV (dBuV)	Correction Factor (dB/m)	Result-PK (dBuV/m)	Result-AV (dBuV/m)	Limit-PK (dBuV/m)	Limit-AV (dBuV/m)	Margin (dB)	Remark
2230.00	41.68	---	3.08	44.76	---	74.00	54.00	-9.24	Peak
3145.00	42.05	---	5.03	47.08	---	74.00	54.00	-6.92	Peak
3840.00	41.42	---	6.12	47.54	---	74.00	54.00	-6.46	Peak
6168.00	38.76	---	12.70	51.46	---	74.00	54.00	-2.54	Peak
7764.00	37.62	---	13.52	51.14	---	74.00	54.00	-2.86	Peak
9036.00	35.76	---	15.21	50.97	---	74.00	54.00	-3.03	Peak

Remark:

1. Measuring frequencies from 1 GHz to the 10th harmonic of highest fundamental frequency.
2. Average test would be performed if the peak result were greater than the average limit.
3. Data of measurement within this frequency range shown " --- " in the table above means the reading of emissions are attenuated more than 20dB below the permissible limits or the field strength is too small to be measured.
4. Measurements above show only up to 6 maximum emissions noted, or would be lesser, with " N/A " remark, if no specific emissions from the EUT are recorded (ie: margin>20dB from the applicable limit) and considered that's already beyond the background noise floor.
5. Result = Reading + Correction Factor
Margin = Result - Limit
Remark Peak = Result(PK) - Limit(AV)
Remark AVG = Result(AV) - Limit(AV)



Product Name	Panel PC	Test By	Audi Chang
Test Model	VM-521	Test Date	2014/11/19
Test Mode	UNII Band 2C / IEEE 802.11ac VHT40 TX / CH Middle / External Antenna	Temp. & Humidity	25°C, 50%

966 Chamber_B at 3Meter / Horizontal									
Frequency (MHz)	Reading-PK (dBuV)	Reading-AV (dBuV)	Correction Factor (dB/m)	Result-PK (dBuV/m)	Result-AV (dBuV/m)	Limit-PK (dBuV/m)	Limit-AV (dBuV/m)	Margin (dB)	Remark
2370.00	42.36	---	3.36	45.71	---	74.00	54.00	-8.29	Peak
3245.00	42.07	---	5.20	47.27	---	74.00	54.00	-6.73	Peak
4575.00	40.31	---	8.81	49.12	---	74.00	54.00	-4.88	Peak
6228.00	38.56	---	12.67	51.23	---	74.00	54.00	-2.77	Peak
7464.00	39.04	---	12.85	51.88	---	74.00	54.00	-2.12	Peak
8856.00	36.70	---	15.26	51.96	---	74.00	54.00	-2.04	Peak

966 Chamber_B at 3Meter / Vertical									
Frequency (MHz)	Reading-PK (dBuV)	Reading-AV (dBuV)	Correction Factor (dB/m)	Result-PK (dBuV/m)	Result-AV (dBuV/m)	Limit-PK (dBuV/m)	Limit-AV (dBuV/m)	Margin (dB)	Remark
2685.00	41.47	---	4.05	45.52	---	74.00	54.00	-8.48	Peak
3680.00	41.20	---	5.89	47.09	---	74.00	54.00	-6.91	Peak
4600.00	40.62	---	8.80	49.42	---	74.00	54.00	-4.58	Peak
6024.00	38.10	---	12.76	50.86	---	74.00	54.00	-3.14	Peak
7356.00	37.81	---	13.13	50.94	---	74.00	54.00	-3.06	Peak
8856.00	36.91	---	15.26	52.17	---	74.00	54.00	-1.83	Peak

Remark:

1. Measuring frequencies from 1 GHz to the 10th harmonic of highest fundamental frequency.
2. Average test would be performed if the peak result were greater than the average limit.
3. Data of measurement within this frequency range shown " --- " in the table above means the reading of emissions are attenuated more than 20dB below the permissible limits or the field strength is too small to be measured.
4. Measurements above show only up to 6 maximum emissions noted, or would be lesser, with " N/A " remark, if no specific emissions from the EUT are recorded (ie: margin>20dB from the applicable limit) and considered that's already beyond the background noise floor.
5. Result = Reading + Correction Factor
Margin = Result - Limit
Remark Peak = Result(PK) - Limit(AV)
Remark AVG = Result(AV) - Limit(AV)



Product Name	Panel PC	Test By	Audi Chang
Test Model	VM-521	Test Date	2014/11/19
Test Mode	UNII Band 2C / IEEE 802.11ac VHT40 TX / CH High / External Antenna	Temp. & Humidity	25°C, 50%

966 Chamber_B at 3Meter / Horizontal

Frequency (MHz)	Reading-PK (dBuV)	Reading-AV (dBuV)	Correction Factor (dB/m)	Result-PK (dBuV/m)	Result-AV (dBuV/m)	Limit-PK (dBuV/m)	Limit-AV (dBuV/m)	Margin (dB)	Remark
2160.00	42.48	---	2.94	45.43	---	74.00	54.00	-8.57	Peak
3135.00	41.81	---	5.02	46.83	---	74.00	54.00	-7.17	Peak
4045.00	40.60	---	6.57	47.18	---	74.00	54.00	-6.82	Peak
6096.00	37.85	---	12.73	50.57	---	74.00	54.00	-3.43	Peak
7320.00	37.99	---	13.23	51.22	---	74.00	54.00	-2.78	Peak
8964.00	36.34	---	15.18	51.52	---	74.00	54.00	-2.48	Peak

966 Chamber_B at 3Meter / Vertical

Frequency (MHz)	Reading-PK (dBuV)	Reading-AV (dBuV)	Correction Factor (dB/m)	Result-PK (dBuV/m)	Result-AV (dBuV/m)	Limit-PK (dBuV/m)	Limit-AV (dBuV/m)	Margin (dB)	Remark
2355.00	42.02	---	3.33	45.35	---	74.00	54.00	-8.65	Peak
3080.00	42.10	---	4.92	47.03	---	74.00	54.00	-6.97	Peak
4160.00	40.65	---	7.15	47.80	---	74.00	54.00	-6.20	Peak
6300.00	38.63	---	12.64	51.27	---	74.00	54.00	-2.73	Peak
7812.00	38.31	---	13.65	51.96	---	74.00	54.00	-2.04	Peak
8796.00	36.89	---	15.31	52.19	---	74.00	54.00	-1.81	Peak

Remark:

1. Measuring frequencies from 1 GHz to the 10th harmonic of highest fundamental frequency.
2. Average test would be performed if the peak result were greater than the average limit.
3. Data of measurement within this frequency range shown " --- " in the table above means the reading of emissions are attenuated more than 20dB below the permissible limits or the field strength is too small to be measured.
4. Measurements above show only up to 6 maximum emissions noted, or would be lesser, with " N/A " remark, if no specific emissions from the EUT are recorded (ie: margin>20dB from the applicable limit) and considered that's already beyond the background noise floor.
5. Result = Reading + Correction Factor
Margin = Result - Limit
Remark Peak = Result(PK) - Limit(AV)
Remark AVG = Result(AV) - Limit(AV)



Product Name	Panel PC	Test By	Audi Chang
Test Model	VM-521	Test Date	2014/11/19
Test Mode	UNII Band 2C / IEEE 802.11ac VHT80 TX / CH Low / External Antenna	Temp. & Humidity	25°C, 50%

966 Chamber_B at 3Meter / Horizontal									
Frequency (MHz)	Reading-PK (dBuV)	Reading-AV (dBuV)	Correction Factor (dB/m)	Result-PK (dBuV/m)	Result-AV (dBuV/m)	Limit-PK (dBuV/m)	Limit-AV (dBuV/m)	Margin (dB)	Remark
1715.00	47.27	---	-0.01	47.26	---	74.00	54.00	-6.74	Peak
2030.00	43.30	---	2.69	45.99	---	74.00	54.00	-8.01	Peak
3130.00	42.38	---	5.01	47.39	---	74.00	54.00	-6.61	Peak
6216.00	38.14	---	12.67	50.82	---	74.00	54.00	-3.18	Peak
7908.00	37.18	---	13.93	51.11	---	74.00	54.00	-2.89	Peak
9756.00	36.04	---	16.29	52.33	---	74.00	54.00	-1.67	Peak

966 Chamber_B at 3Meter / Vertical									
Frequency (MHz)	Reading-PK (dBuV)	Reading-AV (dBuV)	Correction Factor (dB/m)	Result-PK (dBuV/m)	Result-AV (dBuV/m)	Limit-PK (dBuV/m)	Limit-AV (dBuV/m)	Margin (dB)	Remark
2040.00	41.54	---	2.71	44.25	---	74.00	54.00	-9.75	Peak
3265.00	41.86	---	5.24	47.09	---	74.00	54.00	-6.91	Peak
4555.00	40.49	---	8.82	49.31	---	74.00	54.00	-4.69	Peak
6300.00	38.60	---	12.64	51.24	---	74.00	54.00	-2.76	Peak
7632.00	37.79	---	13.13	50.92	---	74.00	54.00	-3.08	Peak
9108.00	37.02	---	15.32	52.34	---	74.00	54.00	-1.66	Peak

Remark:

1. Measuring frequencies from 1 GHz to the 10th harmonic of highest fundamental frequency.
2. Average test would be performed if the peak result were greater than the average limit.
3. Data of measurement within this frequency range shown " --- " in the table above means the reading of emissions are attenuated more than 20dB below the permissible limits or the field strength is too small to be measured.
4. Measurements above show only up to 6 maximum emissions noted, or would be lesser, with " N/A " remark, if no specific emissions from the EUT are recorded (ie: margin>20dB from the applicable limit) and considered that's already beyond the background noise floor.
5. Result = Reading + Correction Factor
Margin = Result - Limit
Remark Peak = Result(PK) - Limit(AV)
Remark AVG = Result(AV) - Limit(AV)



Product Name	Panel PC	Test By	Audi Chang
Test Model	VM-521	Test Date	2014/11/19
Test Mode	UNII Band 3 / IEEE 802.11a TX / CH Low / External Antenna	Temp. & Humidity	25°C, 50%

966 Chamber_B at 3Meter / Horizontal

Frequency (MHz)	Reading-PK (dBuV)	Reading-AV (dBuV)	Correction Factor (dB/m)	Result-PK (dBuV/m)	Result-AV (dBuV/m)	Limit-PK (dBuV/m)	Limit-AV (dBuV/m)	Margin (dB)	Remark
3095.00	43.80	---	4.95	48.75	---	74.00	54.00	-5.25	Peak
4685.00	41.77	---	8.76	50.54	---	74.00	54.00	-3.46	Peak
5455.00	40.38	---	10.42	50.80	---	74.00	54.00	-3.20	Peak
6036.00	37.98	---	12.75	50.73	---	74.00	54.00	-3.27	Peak
7752.00	38.67	---	13.48	52.15	---	74.00	54.00	-1.85	Peak
9084.00	37.08	---	15.29	52.36	---	74.00	54.00	-1.64	Peak

966 Chamber_B at 3Meter / Vertical

Frequency (MHz)	Reading-PK (dBuV)	Reading-AV (dBuV)	Correction Factor (dB/m)	Result-PK (dBuV/m)	Result-AV (dBuV/m)	Limit-PK (dBuV/m)	Limit-AV (dBuV/m)	Margin (dB)	Remark
3060.00	43.28	---	4.89	48.17	---	74.00	54.00	-5.83	Peak
4610.00	42.02	---	8.80	50.81	---	74.00	54.00	-3.19	Peak
5405.00	40.72	---	10.22	50.94	---	74.00	54.00	-3.06	Peak
6108.00	38.69	---	12.72	51.41	---	74.00	54.00	-2.59	Peak
7704.00	38.58	---	13.34	51.92	---	74.00	54.00	-2.08	Peak
8952.00	36.81	---	15.19	52.00	---	74.00	54.00	-2.00	Peak

Remark:

1. Measuring frequencies from 1 GHz to the 10th harmonic of highest fundamental frequency.
2. Average test would be performed if the peak result were greater than the average limit.
3. Data of measurement within this frequency range shown " --- " in the table above means the reading of emissions are attenuated more than 20dB below the permissible limits or the field strength is too small to be measured.
4. Measurements above show only up to 6 maximum emissions noted, or would be lesser, with " N/A " remark, if no specific emissions from the EUT are recorded (ie: margin>20dB from the applicable limit) and considered that's already beyond the background noise floor.
5. Result = Reading + Correction Factor
Margin = Result - Limit
Remark Peak = Result(PK) - Limit(AV)
Remark AVG = Result(AV) - Limit(AV)



Product Name	Panel PC	Test By	Audi Chang
Test Model	VM-521	Test Date	2014/11/19
Test Mode	UNII Band 3 / IEEE 802.11a TX / CH Middle / External Antenna	Temp. & Humidity	25°C, 50%

966 Chamber_B at 3Meter / Horizontal									
Frequency (MHz)	Reading-PK (dBuV)	Reading-AV (dBuV)	Correction Factor (dB/m)	Result-PK (dBuV/m)	Result-AV (dBuV/m)	Limit-PK (dBuV/m)	Limit-AV (dBuV/m)	Margin (dB)	Remark
1705.00	48.53	---	-0.11	48.42	---	74.00	54.00	-5.58	Peak
4635.00	41.96	---	8.79	50.75	---	74.00	54.00	-3.25	Peak
5375.00	41.00	---	10.10	51.11	---	74.00	54.00	-2.89	Peak
6132.00	38.55	---	12.71	51.26	---	74.00	54.00	-2.74	Peak
7716.00	37.84	---	13.38	51.21	---	74.00	54.00	-2.79	Peak
9024.00	37.11	---	15.19	52.29	---	74.00	54.00	-1.71	Peak

966 Chamber_B at 3Meter / Vertical									
Frequency (MHz)	Reading-PK (dBuV)	Reading-AV (dBuV)	Correction Factor (dB/m)	Result-PK (dBuV/m)	Result-AV (dBuV/m)	Limit-PK (dBuV/m)	Limit-AV (dBuV/m)	Margin (dB)	Remark
3085.00	43.80	---	4.93	48.73	---	74.00	54.00	-5.27	Peak
4625.00	42.52	---	8.79	51.31	---	74.00	54.00	-2.69	Peak
5435.00	41.16	---	10.34	51.50	---	74.00	54.00	-2.50	Peak
6300.00	38.22	---	12.64	50.86	---	74.00	54.00	-3.14	Peak
7716.00	37.81	---	13.38	51.18	---	74.00	54.00	-2.82	Peak
9108.00	36.69	---	15.32	52.01	---	74.00	54.00	-1.99	Peak

Remark:

1. Measuring frequencies from 1 GHz to the 10th harmonic of highest fundamental frequency.
2. Average test would be performed if the peak result were greater than the average limit.
3. Data of measurement within this frequency range shown " --- " in the table above means the reading of emissions are attenuated more than 20dB below the permissible limits or the field strength is too small to be measured.
4. Measurements above show only up to 6 maximum emissions noted, or would be lesser, with " N/A " remark, if no specific emissions from the EUT are recorded (ie: margin>20dB from the applicable limit) and considered that's already beyond the background noise floor.
5. Result = Reading + Correction Factor
Margin = Result - Limit
Remark Peak = Result(PK) - Limit(AV)
Remark AVG = Result(AV) - Limit(AV)



Product Name	Panel PC	Test By	Audi Chang
Test Model	VM-521	Test Date	2014/11/19
Test Mode	UNII Band 3 / IEEE 802.11a TX / CH High / External Antenna	Temp. & Humidity	25°C, 50%

966 Chamber_B at 3Meter / Horizontal									
Frequency (MHz)	Reading-PK (dBuV)	Reading-AV (dBuV)	Correction Factor (dB/m)	Result-PK (dBuV/m)	Result-AV (dBuV/m)	Limit-PK (dBuV/m)	Limit-AV (dBuV/m)	Margin (dB)	Remark
3140.00	43.68	---	5.03	48.71	---	74.00	54.00	-5.29	Peak
4525.00	43.29	---	8.84	52.13	---	74.00	54.00	-1.87	Peak
5455.00	41.13	---	10.42	51.55	---	74.00	54.00	-2.45	Peak
6132.00	38.00	---	12.71	50.71	---	74.00	54.00	-3.29	Peak
7644.00	37.08	---	13.17	50.24	---	74.00	54.00	-3.76	Peak
8868.00	36.97	---	15.25	52.23	---	74.00	54.00	-1.77	Peak

966 Chamber_B at 3Meter / Vertical									
Frequency (MHz)	Reading-PK (dBuV)	Reading-AV (dBuV)	Correction Factor (dB/m)	Result-PK (dBuV/m)	Result-AV (dBuV/m)	Limit-PK (dBuV/m)	Limit-AV (dBuV/m)	Margin (dB)	Remark
3075.00	43.89	---	4.92	48.81	---	74.00	54.00	-5.19	Peak
4660.00	41.88	---	8.77	50.66	---	74.00	54.00	-3.34	Peak
5385.00	41.16	---	10.14	51.30	---	74.00	54.00	-2.70	Peak
6372.00	38.67	---	12.61	51.27	---	74.00	54.00	-2.73	Peak
7632.00	38.57	---	13.13	51.71	---	74.00	54.00	-2.29	Peak
8952.00	36.17	---	15.19	51.35	---	74.00	54.00	-2.65	Peak

Remark:

1. Measuring frequencies from 1 GHz to the 10th harmonic of highest fundamental frequency.
2. Average test would be performed if the peak result were greater than the average limit.
3. Data of measurement within this frequency range shown " --- " in the table above means the reading of emissions are attenuated more than 20dB below the permissible limits or the field strength is too small to be measured.
4. Measurements above show only up to 6 maximum emissions noted, or would be lesser, with " N/A " remark, if no specific emissions from the EUT are recorded (ie: margin>20dB from the applicable limit) and considered that's already beyond the background noise floor.
5. Result = Reading + Correction Factor
Margin = Result - Limit
Remark Peak = Result(PK) - Limit(AV)
Remark AVG = Result(AV) - Limit(AV)



Product Name	Panel PC	Test By	Audi Chang
Test Model	VM-521	Test Date	2014/11/19
Test Mode	UNII Band 3 / IEEE 802.11ac VHT20 TX / CH Low / External Antenna	Temp. & Humidity	25°C, 50%

966 Chamber_B at 3Meter / Horizontal									
Frequency (MHz)	Reading-PK (dBuV)	Reading-AV (dBuV)	Correction Factor (dB/m)	Result-PK (dBuV/m)	Result-AV (dBuV/m)	Limit-PK (dBuV/m)	Limit-AV (dBuV/m)	Margin (dB)	Remark
3165.00	43.50	---	5.07	48.56	---	74.00	54.00	-5.44	Peak
4585.00	41.89	---	8.81	50.70	---	74.00	54.00	-3.30	Peak
5355.00	41.14	---	10.02	51.17	---	74.00	54.00	-2.83	Peak
6372.00	38.52	---	12.61	51.13	---	74.00	54.00	-2.87	Peak
7632.00	38.05	---	13.13	51.19	---	74.00	54.00	-2.81	Peak
9048.00	36.75	---	15.23	51.98	---	74.00	54.00	-2.02	Peak

966 Chamber_B at 3Meter / Vertical									
Frequency (MHz)	Reading-PK (dBuV)	Reading-AV (dBuV)	Correction Factor (dB/m)	Result-PK (dBuV/m)	Result-AV (dBuV/m)	Limit-PK (dBuV/m)	Limit-AV (dBuV/m)	Margin (dB)	Remark
3365.00	43.97	---	5.40	49.37	---	74.00	54.00	-4.63	Peak
4640.00	41.55	---	8.78	50.34	---	74.00	54.00	-3.66	Peak
5390.00	40.77	---	10.16	50.93	---	74.00	54.00	-3.07	Peak
6216.00	39.22	---	12.67	51.89	---	74.00	54.00	-2.11	Peak
7284.00	38.41	---	13.32	51.73	---	74.00	54.00	-2.27	Peak
9108.00	35.79	---	15.32	51.12	---	74.00	54.00	-2.88	Peak

Remark:

1. Measuring frequencies from 1 GHz to the 10th harmonic of highest fundamental frequency.
2. Average test would be performed if the peak result were greater than the average limit.
3. Data of measurement within this frequency range shown " --- " in the table above means the reading of emissions are attenuated more than 20dB below the permissible limits or the field strength is too small to be measured.
4. Measurements above show only up to 6 maximum emissions noted, or would be lesser, with " N/A " remark, if no specific emissions from the EUT are recorded (ie: margin>20dB from the applicable limit) and considered that's already beyond the background noise floor.
5. Result = Reading + Correction Factor
Margin = Result - Limit
Remark Peak = Result(PK) - Limit(AV)
Remark AVG = Result(AV) - Limit(AV)



Product Name	Panel PC	Test By	Audi Chang
Test Model	VM-521	Test Date	2014/11/19
Test Mode	UNII Band 3 / IEEE 802.11ac VHT20 TX / CH Middle / External Antenna	Temp. & Humidity	25°C, 50%

966 Chamber_B at 3Meter / Horizontal									
Frequency (MHz)	Reading-PK (dBuV)	Reading-AV (dBuV)	Correction Factor (dB/m)	Result-PK (dBuV/m)	Result-AV (dBuV/m)	Limit-PK (dBuV/m)	Limit-AV (dBuV/m)	Margin (dB)	Remark
3350.00	42.97	---	5.38	48.35	---	74.00	54.00	-5.65	Peak
4660.00	42.12	---	8.77	50.90	---	74.00	54.00	-3.10	Peak
5450.00	40.83	---	10.40	51.23	---	74.00	54.00	-2.77	Peak
6012.00	39.20	---	12.76	51.97	---	74.00	54.00	-2.03	Peak
7584.00	38.54	---	12.99	51.53	---	74.00	54.00	-2.47	Peak
8928.00	36.63	---	15.20	51.83	---	74.00	54.00	-2.17	Peak

966 Chamber_B at 3Meter / Vertical									
Frequency (MHz)	Reading-PK (dBuV)	Reading-AV (dBuV)	Correction Factor (dB/m)	Result-PK (dBuV/m)	Result-AV (dBuV/m)	Limit-PK (dBuV/m)	Limit-AV (dBuV/m)	Margin (dB)	Remark
3235.00	44.49	---	5.18	49.67	---	74.00	54.00	-4.33	Peak
4665.00	41.44	---	8.77	50.21	---	74.00	54.00	-3.79	Peak
5435.00	40.66	---	10.34	51.01	---	74.00	54.00	-2.99	Peak
6192.00	39.02	---	12.69	51.71	---	74.00	54.00	-2.29	Peak
7464.00	38.61	---	12.85	51.45	---	74.00	54.00	-2.55	Peak
8976.00	37.36	---	15.17	52.53	---	74.00	54.00	-1.47	Peak

Remark:

1. Measuring frequencies from 1 GHz to the 10th harmonic of highest fundamental frequency.
2. Average test would be performed if the peak result were greater than the average limit.
3. Data of measurement within this frequency range shown " --- " in the table above means the reading of emissions are attenuated more than 20dB below the permissible limits or the field strength is too small to be measured.
4. Measurements above show only up to 6 maximum emissions noted, or would be lesser, with " N/A " remark, if no specific emissions from the EUT are recorded (ie: margin>20dB from the applicable limit) and considered that's already beyond the background noise floor.
5. Result = Reading + Correction Factor
Margin = Result - Limit
Remark Peak = Result(PK) - Limit(AV)
Remark AVG = Result(AV) - Limit(AV)



Product Name	Panel PC	Test By	Audi Chang
Test Model	VM-521	Test Date	2014/11/19
Test Mode	UNII Band 3 / IEEE 802.11ac VHT20 TX / CH High / External Antenna	Temp. & Humidity	25°C, 50%

966 Chamber_B at 3Meter / Horizontal									
Frequency (MHz)	Reading-PK (dBuV)	Reading-AV (dBuV)	Correction Factor (dB/m)	Result-PK (dBuV/m)	Result-AV (dBuV/m)	Limit-PK (dBuV/m)	Limit-AV (dBuV/m)	Margin (dB)	Remark
3210.00	44.23	---	5.14	49.37	---	74.00	54.00	-4.63	Peak
4575.00	42.18	---	8.81	50.99	---	74.00	54.00	-3.01	Peak
5395.00	40.18	---	10.18	50.36	---	74.00	54.00	-3.64	Peak
6024.00	38.25	---	12.76	51.01	---	74.00	54.00	-2.99	Peak
7548.00	37.83	---	12.89	50.72	---	74.00	54.00	-3.28	Peak
8904.00	36.91	---	15.22	52.13	---	74.00	54.00	-1.87	Peak

966 Chamber_B at 3Meter / Vertical									
Frequency (MHz)	Reading-PK (dBuV)	Reading-AV (dBuV)	Correction Factor (dB/m)	Result-PK (dBuV/m)	Result-AV (dBuV/m)	Limit-PK (dBuV/m)	Limit-AV (dBuV/m)	Margin (dB)	Remark
3245.00	43.88	---	5.20	49.09	---	74.00	54.00	-4.91	Peak
4640.00	42.09	---	8.78	50.87	---	74.00	54.00	-3.13	Peak
5455.00	40.68	---	10.42	51.10	---	74.00	54.00	-2.90	Peak
6120.00	38.68	---	12.72	51.40	---	74.00	54.00	-2.60	Peak
7632.00	38.71	---	13.13	51.84	---	74.00	54.00	-2.16	Peak
8976.00	36.85	---	15.17	52.02	---	74.00	54.00	-1.98	Peak

Remark:

1. Measuring frequencies from 1 GHz to the 10th harmonic of highest fundamental frequency.
2. Average test would be performed if the peak result were greater than the average limit.
3. Data of measurement within this frequency range shown " --- " in the table above means the reading of emissions are attenuated more than 20dB below the permissible limits or the field strength is too small to be measured.
4. Measurements above show only up to 6 maximum emissions noted, or would be lesser, with " N/A " remark, if no specific emissions from the EUT are recorded (ie: margin>20dB from the applicable limit) and considered that's already beyond the background noise floor.
5. Result = Reading + Correction Factor
Margin = Result - Limit
Remark Peak = Result(PK) - Limit(AV)
Remark AVG = Result(AV) - Limit(AV)



Product Name	Panel PC	Test By	Audi Chang
Test Model	TREK-674	Test Date	2014/11/19
Test Mode	UNII Band 3 / IEEE 802.11ac VHT40 TX / CH Low / External Antenna	Temp. & Humidity	25°C, 50%

966 Chamber_B at 3Meter / Horizontal									
Frequency (MHz)	Reading-PK (dBuV)	Reading-AV (dBuV)	Correction Factor (dB/m)	Result-PK (dBuV/m)	Result-AV (dBuV/m)	Limit-PK (dBuV/m)	Limit-AV (dBuV/m)	Margin (dB)	Remark
3320.00	43.86	---	5.33	49.19	---	74.00	54.00	-4.81	Peak
4615.00	42.69	---	8.79	51.49	---	74.00	54.00	-2.51	Peak
5380.00	40.68	---	10.12	50.80	---	74.00	54.00	-3.20	Peak
6108.00	38.12	---	12.72	50.84	---	74.00	54.00	-3.16	Peak
7764.00	37.19	---	13.52	50.71	---	74.00	54.00	-3.29	Peak
8988.00	35.96	---	15.16	51.12	---	74.00	54.00	-2.88	Peak

966 Chamber_B at 3Meter / Vertical									
Frequency (MHz)	Reading-PK (dBuV)	Reading-AV (dBuV)	Correction Factor (dB/m)	Result-PK (dBuV/m)	Result-AV (dBuV/m)	Limit-PK (dBuV/m)	Limit-AV (dBuV/m)	Margin (dB)	Remark
3155.00	43.81	---	5.05	48.86	---	74.00	54.00	-5.14	Peak
4745.00	43.00	---	8.73	51.73	---	74.00	54.00	-2.27	Peak
5420.00	41.28	---	10.28	51.56	---	74.00	54.00	-2.44	Peak
6108.00	39.21	---	12.72	51.93	---	74.00	54.00	-2.07	Peak
7368.00	38.69	---	13.10	51.79	---	74.00	54.00	-2.21	Peak
8880.00	36.85	---	15.24	52.10	---	74.00	54.00	-1.90	Peak

Remark:

1. Measuring frequencies from 1 GHz to the 10th harmonic of highest fundamental frequency.
2. Average test would be performed if the peak result were greater than the average limit.
3. Data of measurement within this frequency range shown " --- " in the table above means the reading of emissions are attenuated more than 20dB below the permissible limits or the field strength is too small to be measured.
4. Measurements above show only up to 6 maximum emissions noted, or would be lesser, with " N/A " remark, if no specific emissions from the EUT are recorded (ie: margin>20dB from the applicable limit) and considered that's already beyond the background noise floor.
5. Result = Reading + Correction Factor
Margin = Result - Limit
Remark Peak = Result(PK) - Limit(AV)
Remark AVG = Result(AV) - Limit(AV)



Product Name	Panel PC	Test By	Audi Chang
Test Model	VM-521	Test Date	2014/11/19
Test Mode	UNII Band 3 / IEEE 802.11ac VHT40 TX / CH High / External Antenna	Temp. & Humidity	25°C, 50%

966 Chamber_B at 3Meter / Horizontal									
Frequency (MHz)	Reading-PK (dBuV)	Reading-AV (dBuV)	Correction Factor (dB/m)	Result-PK (dBuV/m)	Result-AV (dBuV/m)	Limit-PK (dBuV/m)	Limit-AV (dBuV/m)	Margin (dB)	Remark
3145.00	43.69	---	5.03	48.73	---	74.00	54.00	-5.27	Peak
4625.00	42.19	---	8.79	50.98	---	74.00	54.00	-3.02	Peak
5430.00	40.82	---	10.32	51.14	---	74.00	54.00	-2.86	Peak
6072.00	37.80	---	12.74	50.54	---	74.00	54.00	-3.46	Peak
7212.00	37.75	---	13.51	51.26	---	74.00	54.00	-2.74	Peak
9012.00	36.85	---	15.17	52.02	---	74.00	54.00	-1.98	Peak

966 Chamber_B at 3Meter / Vertical									
Frequency (MHz)	Reading-PK (dBuV)	Reading-AV (dBuV)	Correction Factor (dB/m)	Result-PK (dBuV/m)	Result-AV (dBuV/m)	Limit-PK (dBuV/m)	Limit-AV (dBuV/m)	Margin (dB)	Remark
3140.00	44.15	---	5.03	49.17	---	74.00	54.00	-4.83	Peak
4645.00	42.04	---	8.78	50.83	---	74.00	54.00	-3.17	Peak
5445.00	40.87	---	10.38	51.25	---	74.00	54.00	-2.75	Peak
6096.00	38.82	---	12.73	51.54	---	74.00	54.00	-2.46	Peak
7272.00	37.77	---	13.35	51.12	---	74.00	54.00	-2.88	Peak
8856.00	36.98	---	15.26	52.24	---	74.00	54.00	-1.76	Peak

Remark:

1. Measuring frequencies from 1 GHz to the 10th harmonic of highest fundamental frequency.
2. Average test would be performed if the peak result were greater than the average limit.
3. Data of measurement within this frequency range shown " --- " in the table above means the reading of emissions are attenuated more than 20dB below the permissible limits or the field strength is too small to be measured.
4. Measurements above show only up to 6 maximum emissions noted, or would be lesser, with " N/A " remark, if no specific emissions from the EUT are recorded (ie: margin>20dB from the applicable limit) and considered that's already beyond the background noise floor.
5. Result = Reading + Correction Factor
Margin = Result - Limit
Remark Peak = Result(PK) - Limit(AV)
Remark AVG = Result(AV) - Limit(AV)



Product Name	Panel PC	Test By	Audi Chang
Test Model	VM-521	Test Date	2014/11/19
Test Mode	UNII Band 3 / IEEE 802.11ac VHT80 TX / CH Low / External Antenna	Temp. & Humidity	25°C, 50%

966 Chamber_B at 3Meter / Horizontal

Frequency (MHz)	Reading-PK (dBuV)	Reading-AV (dBuV)	Correction Factor (dB/m)	Result-PK (dBuV/m)	Result-AV (dBuV/m)	Limit-PK (dBuV/m)	Limit-AV (dBuV/m)	Margin (dB)	Remark
1795.00	47.45	---	0.73	48.18	---	74.00	54.00	-5.82	Peak
4635.00	42.36	---	8.79	51.14	---	74.00	54.00	-2.86	Peak
5445.00	40.72	---	10.38	51.10	---	74.00	54.00	-2.90	Peak
6132.00	38.35	---	12.71	51.06	---	74.00	54.00	-2.94	Peak
7560.00	37.86	---	12.92	50.78	---	74.00	54.00	-3.22	Peak
9120.00	37.23	---	15.34	52.58	---	74.00	54.00	-1.42	Peak

966 Chamber_B at 3Meter / Vertical

Frequency (MHz)	Reading-PK (dBuV)	Reading-AV (dBuV)	Correction Factor (dB/m)	Result-PK (dBuV/m)	Result-AV (dBuV/m)	Limit-PK (dBuV/m)	Limit-AV (dBuV/m)	Margin (dB)	Remark
2875.00	43.53	---	4.49	48.02	---	74.00	54.00	-5.98	Peak
4725.00	42.72	---	8.74	51.47	---	74.00	54.00	-2.53	Peak
5455.00	40.78	---	10.42	51.20	---	74.00	54.00	-2.80	Peak
6192.00	37.70	---	12.69	50.39	---	74.00	54.00	-3.61	Peak
7500.00	38.20	---	12.75	50.95	---	74.00	54.00	-3.05	Peak
9072.00	36.88	---	15.27	52.15	---	74.00	54.00	-1.85	Peak

Remark:

1. Measuring frequencies from 1 GHz to the 10th harmonic of highest fundamental frequency.
2. Average test would be performed if the peak result were greater than the average limit.
3. Data of measurement within this frequency range shown " --- " in the table above means the reading of emissions are attenuated more than 20dB below the permissible limits or the field strength is too small to be measured.
4. Measurements above show only up to 6 maximum emissions noted, or would be lesser, with " N/A " remark, if no specific emissions from the EUT are recorded (ie: margin>20dB from the applicable limit) and considered that's already beyond the background noise floor.
5. Result = Reading + Correction Factor
Margin = Result - Limit
Remark Peak = Result(PK) - Limit(AV)
Remark AVG = Result(AV) - Limit(AV)



Product Name	Panel PC	Test By	Davis Tseng
Test Model	VM-521	Test Date	2014/11/20
Test Mode	UNII Band 1/ IEEE 802.11a TX / CH Low / Internal Antenna	Temp. & Humidity	24.5°C, 33%

966 Chamber_B at 3Meter / Horizontal									
Frequency (MHz)	Reading-PK (dBuV)	Reading-AV (dBuV)	Correction Factor (dB/m)	Result-PK (dBuV/m)	Result-AV (dBuV/m)	Limit-PK (dBuV/m)	Limit-AV (dBuV/m)	Margin (dB)	Remark
1715.00	47.75	---	-0.01	47.73	---	74.00	54.00	-6.27	Peak
3840.00	41.82	---	6.12	47.94	---	74.00	54.00	-6.06	Peak
4565.00	40.74	---	8.82	49.56	---	74.00	54.00	-4.44	Peak
6120.00	38.82	---	12.72	51.54	---	74.00	54.00	-2.46	Peak
7656.00	37.91	---	13.20	51.11	---	74.00	54.00	-2.89	Peak
9060.00	37.32	---	15.25	52.57	---	74.00	54.00	-1.43	Peak

966 Chamber_B at 3Meter / Vertical									
Frequency (MHz)	Reading-PK (dBuV)	Reading-AV (dBuV)	Correction Factor (dB/m)	Result-PK (dBuV/m)	Result-AV (dBuV/m)	Limit-PK (dBuV/m)	Limit-AV (dBuV/m)	Margin (dB)	Remark
3150.00	41.98	---	5.04	47.03	---	74.00	54.00	-6.97	Peak
3840.00	41.33	---	6.12	47.45	---	74.00	54.00	-6.55	Peak
4780.00	41.11	---	8.72	49.83	---	74.00	54.00	-4.17	Peak
5395.00	39.32	---	10.18	49.51	---	74.00	54.00	-4.49	Peak
6300.00	38.53	---	12.64	51.17	---	74.00	54.00	-2.83	Peak
6720.00	38.47	---	13.22	51.69	---	74.00	54.00	-2.31	Peak
7920.00	37.88	---	13.97	51.85	---	74.00	54.00	-2.15	Peak

Remark:

1. Measuring frequencies from 1 GHz to the 10th harmonic of highest fundamental frequency.
2. Average test would be performed if the peak result were greater than the average limit.
3. Data of measurement within this frequency range shown " --- " in the table above means the reading of emissions are attenuated more than 20dB below the permissible limits or the field strength is too small to be measured.
4. Measurements above show only up to 6 maximum emissions noted, or would be lesser, with " N/A " remark, if no specific emissions from the EUT are recorded (ie: margin>20dB from the applicable limit) and considered that's already beyond the background noise floor.
5. Result = Reading + Correction Factor
Margin = Result - Limit
Remark Peak = Result(PK) - Limit(AV)
Remark AVG = Result(AV) - Limit(AV)



Product Name	Panel PC	Test By	Davis Tseng
Test Model	VM-521	Test Date	2014/11/20
Test Mode	UNII Band 1/ IEEE 802.11a TX / CH Middle / Internal Antenna	Temp. & Humidity	24.5°C, 33%

966 Chamber_B at 3Meter / Horizontal

Frequency (MHz)	Reading-PK (dBuV)	Reading-AV (dBuV)	Correction Factor (dB/m)	Result-PK (dBuV/m)	Result-AV (dBuV/m)	Limit-PK (dBuV/m)	Limit-AV (dBuV/m)	Margin (dB)	Remark
1715.00	46.34	---	-0.01	46.33	---	74.00	54.00	-7.67	Peak
3895.00	41.31	---	6.20	47.51	---	74.00	54.00	-6.49	Peak
4480.00	39.96	---	8.75	48.71	---	74.00	54.00	-5.29	Peak
5420.00	39.59	---	10.28	49.87	---	74.00	54.00	-4.13	Peak
6084.00	38.85	---	12.73	51.58	---	74.00	54.00	-2.42	Peak
7176.00	38.35	---	13.61	51.96	---	74.00	54.00	-2.04	Peak
9000.00	36.98	---	15.15	52.13	---	74.00	54.00	-1.87	Peak

966 Chamber_B at 3Meter / Vertical

Frequency (MHz)	Reading-PK (dBuV)	Reading-AV (dBuV)	Correction Factor (dB/m)	Result-PK (dBuV/m)	Result-AV (dBuV/m)	Limit-PK (dBuV/m)	Limit-AV (dBuV/m)	Margin (dB)	Remark
3220.00	42.16	---	5.16	47.32	---	74.00	54.00	-6.68	Peak
3475.00	41.92	---	5.59	47.51	---	74.00	54.00	-6.49	Peak
4665.00	40.72	---	8.77	49.49	---	74.00	54.00	-4.51	Peak
5415.00	38.87	---	10.26	49.13	---	74.00	54.00	-4.87	Peak
6324.00	39.47	---	12.63	52.10	---	74.00	54.00	-1.90	Peak
7500.00	38.55	---	12.75	51.30	---	74.00	54.00	-2.70	Peak
9072.00	37.32	---	15.27	52.59	---	74.00	54.00	-1.41	Peak

Remark:

1. Measuring frequencies from 1 GHz to the 10th harmonic of highest fundamental frequency.
2. Average test would be performed if the peak result were greater than the average limit.
3. Data of measurement within this frequency range shown " --- " in the table above means the reading of emissions are attenuated more than 20dB below the permissible limits or the field strength is too small to be measured.
4. Measurements above show only up to 6 maximum emissions noted, or would be lesser, with " N/A " remark, if no specific emissions from the EUT are recorded (ie: margin>20dB from the applicable limit) and considered that's already beyond the background noise floor.
5. Result = Reading + Correction Factor
Margin = Result - Limit
Remark Peak = Result(PK) - Limit(AV)
Remark AVG = Result(AV) - Limit(AV)



Product Name	Panel PC	Test By	Davis Tseng
Test Model	VM-521	Test Date	2014/11/20
Test Mode	UNII Band 1/ IEEE 802.11a TX / CH High / Internal Antenna	Temp. & Humidity	24.5°C, 33%

966 Chamber_B at 3Meter / Horizontal									
Frequency (MHz)	Reading-PK (dBuV)	Reading-AV (dBuV)	Correction Factor (dB/m)	Result-PK (dBuV/m)	Result-AV (dBuV/m)	Limit-PK (dBuV/m)	Limit-AV (dBuV/m)	Margin (dB)	Remark
1685.00	46.75	---	-0.29	46.46	---	74.00	54.00	-7.54	Peak
3220.00	43.12	---	5.16	48.28	---	74.00	54.00	-5.72	Peak
4610.00	41.25	---	8.80	50.05	---	74.00	54.00	-3.95	Peak
5470.00	39.88	---	10.48	50.36	---	74.00	54.00	-3.64	Peak
6288.00	38.50	---	12.64	51.14	---	74.00	54.00	-2.86	Peak
7344.00	37.96	---	13.16	51.13	---	74.00	54.00	-2.87	Peak
8988.00	36.45	---	15.16	51.61	---	74.00	54.00	-2.39	Peak

966 Chamber_B at 3Meter / Vertical									
Frequency (MHz)	Reading-PK (dBuV)	Reading-AV (dBuV)	Correction Factor (dB/m)	Result-PK (dBuV/m)	Result-AV (dBuV/m)	Limit-PK (dBuV/m)	Limit-AV (dBuV/m)	Margin (dB)	Remark
2175.00	41.95	---	2.97	44.92	---	74.00	54.00	-9.08	Peak
3345.00	42.45	---	5.37	47.82	---	74.00	54.00	-6.18	Peak
4640.00	41.42	---	8.78	50.20	---	74.00	54.00	-3.80	Peak
5420.00	38.84	---	10.28	49.12	---	74.00	54.00	-4.88	Peak
6036.00	38.67	---	12.75	51.42	---	74.00	54.00	-2.58	Peak
7572.00	37.79	---	12.96	50.75	---	74.00	54.00	-3.25	Peak
8916.00	36.76	---	15.21	51.98	---	74.00	54.00	-2.02	Peak

Remark:

1. Measuring frequencies from 1 GHz to the 10th harmonic of highest fundamental frequency.
2. Average test would be performed if the peak result were greater than the average limit.
3. Data of measurement within this frequency range shown " --- " in the table above means the reading of emissions are attenuated more than 20dB below the permissible limits or the field strength is too small to be measured.
4. Measurements above show only up to 6 maximum emissions noted, or would be lesser, with " N/A " remark, if no specific emissions from the EUT are recorded (ie: margin>20dB from the applicable limit) and considered that's already beyond the background noise floor.
5. Result = Reading + Correction Factor
Margin = Result - Limit
Remark Peak = Result(PK) - Limit(AV)
Remark AVG = Result(AV) - Limit(AV)



Product Name	Panel PC	Test By	Davis Tseng
Test Model	VM-521	Test Date	2014/11/20
Test Mode	UNII Band 1/ IEEE 802.11ac VHT20 TX / CH Low / Internal Antenna	Temp. & Humidity	24.5°C, 33%

966 Chamber_B at 3Meter / Horizontal									
Frequency (MHz)	Reading-PK (dBuV)	Reading-AV (dBuV)	Correction Factor (dB/m)	Result-PK (dBuV/m)	Result-AV (dBuV/m)	Limit-PK (dBuV/m)	Limit-AV (dBuV/m)	Margin (dB)	Remark
1705.00	46.18	---	-0.11	46.07	---	74.00	54.00	-7.93	Peak
3110.00	42.69	---	4.97	47.66	---	74.00	54.00	-6.34	Peak
4620.00	40.54	---	8.79	49.33	---	74.00	54.00	-4.67	Peak
5435.00	39.14	---	10.34	49.48	---	74.00	54.00	-4.52	Peak
6216.00	38.00	---	12.67	50.68	---	74.00	54.00	-3.32	Peak
7908.00	38.11	---	13.93	52.04	---	74.00	54.00	-1.96	Peak
9048.00	36.75	---	15.23	51.97	---	74.00	54.00	-2.03	Peak

966 Chamber_B at 3Meter / Vertical									
Frequency (MHz)	Reading-PK (dBuV)	Reading-AV (dBuV)	Correction Factor (dB/m)	Result-PK (dBuV/m)	Result-AV (dBuV/m)	Limit-PK (dBuV/m)	Limit-AV (dBuV/m)	Margin (dB)	Remark
3180.00	42.21	---	5.09	47.31	---	74.00	54.00	-6.69	Peak
3865.00	42.37	---	6.16	48.52	---	74.00	54.00	-5.48	Peak
4810.00	40.24	---	8.70	48.94	---	74.00	54.00	-5.06	Peak
5425.00	38.64	---	10.30	48.95	---	74.00	54.00	-5.05	Peak
6108.00	38.69	---	12.72	51.41	---	74.00	54.00	-2.59	Peak
8040.00	37.51	---	14.31	51.82	---	74.00	54.00	-2.18	Peak
8964.00	37.17	---	15.18	52.35	---	74.00	54.00	-1.65	Peak

Remark:

1. Measuring frequencies from 1 GHz to the 10th harmonic of highest fundamental frequency.
2. Average test would be performed if the peak result were greater than the average limit.
3. Data of measurement within this frequency range shown " --- " in the table above means the reading of emissions are attenuated more than 20dB below the permissible limits or the field strength is too small to be measured.
4. Measurements above show only up to 6 maximum emissions noted, or would be lesser, with " N/A " remark, if no specific emissions from the EUT are recorded (ie: margin>20dB from the applicable limit) and considered that's already beyond the background noise floor.
5. Result = Reading + Correction Factor
Margin = Result - Limit
Remark Peak = Result(PK) - Limit(AV)
Remark AVG = Result(AV) - Limit(AV)



Product Name	Panel PC	Test By	Davis Tseng
Test Model	VM-521	Test Date	2014/11/20
Test Mode	UNII Band 1/ IEEE 802.11ac VHT20 TX / CH Middle / Internal Antenna	Temp. & Humidity	24.5°C, 33%

966 Chamber_B at 3Meter / Horizontal									
Frequency (MHz)	Reading-PK (dBuV)	Reading-AV (dBuV)	Correction Factor (dB/m)	Result-PK (dBuV/m)	Result-AV (dBuV/m)	Limit-PK (dBuV/m)	Limit-AV (dBuV/m)	Margin (dB)	Remark
2715.00	42.57	---	4.12	46.69	---	74.00	54.00	-7.31	Peak
4605.00	41.05	---	8.80	49.85	---	74.00	54.00	-4.15	Peak
4725.00	41.09	---	8.74	49.83	---	74.00	54.00	-4.17	Peak
5355.00	39.67	---	10.02	49.69	---	74.00	54.00	-4.31	Peak
6216.00	38.43	---	12.67	51.11	---	74.00	54.00	-2.89	Peak
7800.00	38.37	---	13.62	51.99	---	74.00	54.00	-2.01	Peak
9132.00	36.21	---	15.36	51.58	---	74.00	54.00	-2.42	Peak

966 Chamber_B at 3Meter / Vertical									
Frequency (MHz)	Reading-PK (dBuV)	Reading-AV (dBuV)	Correction Factor (dB/m)	Result-PK (dBuV/m)	Result-AV (dBuV/m)	Limit-PK (dBuV/m)	Limit-AV (dBuV/m)	Margin (dB)	Remark
3260.00	42.89	---	5.23	48.12	---	74.00	54.00	-5.88	Peak
4385.00	40.14	---	8.28	48.41	---	74.00	54.00	-5.59	Peak
4625.00	40.31	---	8.79	49.10	---	74.00	54.00	-4.90	Peak
5400.00	39.04	---	10.20	49.24	---	74.00	54.00	-4.76	Peak
6108.00	38.64	---	12.72	51.37	---	74.00	54.00	-2.63	Peak
7848.00	38.36	---	13.76	52.11	---	74.00	54.00	-1.89	Peak
9036.00	36.03	---	15.21	51.24	---	74.00	54.00	-2.76	Peak

Remark:

1. Measuring frequencies from 1 GHz to the 10th harmonic of highest fundamental frequency.
2. Average test would be performed if the peak result were greater than the average limit.
3. Data of measurement within this frequency range shown " --- " in the table above means the reading of emissions are attenuated more than 20dB below the permissible limits or the field strength is too small to be measured.
4. Measurements above show only up to 6 maximum emissions noted, or would be lesser, with " N/A " remark, if no specific emissions from the EUT are recorded (ie: margin>20dB from the applicable limit) and considered that's already beyond the background noise floor.
5. Result = Reading + Correction Factor
Margin = Result - Limit
Remark Peak = Result(PK) - Limit(AV)
Remark AVG = Result(AV) - Limit(AV)



Product Name	Panel PC	Test By	Davis Tseng
Test Model	VM-521	Test Date	2014/11/20
Test Mode	UNII Band 1/ IEEE 802.11ac VHT20 TX / CH High / Internal Antenna	Temp. & Humidity	24.5°C, 33%

966 Chamber_B at 3Meter / Horizontal

Frequency (MHz)	Reading-PK (dBuV)	Reading-AV (dBuV)	Correction Factor (dB/m)	Result-PK (dBuV/m)	Result-AV (dBuV/m)	Limit-PK (dBuV/m)	Limit-AV (dBuV/m)	Margin (dB)	Remark
2620.00	42.54	---	3.89	46.43	---	74.00	54.00	-7.57	Peak
4330.00	40.16	---	8.00	48.16	---	74.00	54.00	-5.84	Peak
4590.00	40.04	---	8.81	48.85	---	74.00	54.00	-5.15	Peak
5415.00	39.23	---	10.26	49.50	---	74.00	54.00	-4.50	Peak
6132.00	38.07	---	12.71	50.79	---	74.00	54.00	-3.21	Peak
7308.00	38.65	---	13.26	51.91	---	74.00	54.00	-2.09	Peak
7884.00	37.65	---	13.86	51.51	---	74.00	54.00	-2.49	Peak

966 Chamber_B at 3Meter / Vertical

Frequency (MHz)	Reading-PK (dBuV)	Reading-AV (dBuV)	Correction Factor (dB/m)	Result-PK (dBuV/m)	Result-AV (dBuV/m)	Limit-PK (dBuV/m)	Limit-AV (dBuV/m)	Margin (dB)	Remark
3205.00	42.44	---	5.13	47.57	---	74.00	54.00	-6.43	Peak
4080.00	41.42	---	6.75	48.17	---	74.00	54.00	-5.83	Peak
4555.00	40.57	---	8.82	49.40	---	74.00	54.00	-4.60	Peak
5400.00	39.62	---	10.20	49.82	---	74.00	54.00	-4.18	Peak
6240.00	38.37	---	12.66	51.03	---	74.00	54.00	-2.97	Peak
8160.00	36.43	---	14.63	51.05	---	74.00	54.00	-2.95	Peak
8976.00	36.10	---	15.17	51.27	---	74.00	54.00	-2.73	Peak

Remark:

1. Measuring frequencies from 1 GHz to the 10th harmonic of highest fundamental frequency.
2. Average test would be performed if the peak result were greater than the average limit.
3. Data of measurement within this frequency range shown " --- " in the table above means the reading of emissions are attenuated more than 20dB below the permissible limits or the field strength is too small to be measured.
4. Measurements above show only up to 6 maximum emissions noted, or would be lesser, with " N/A " remark, if no specific emissions from the EUT are recorded (ie: margin>20dB from the applicable limit) and considered that's already beyond the background noise floor.
5. Result = Reading + Correction Factor
Margin = Result - Limit
Remark Peak = Result(PK) - Limit(AV)
Remark AVG = Result(AV) - Limit(AV)



Product Name	Panel PC	Test By	Davis Tseng
Test Model	VM-521	Test Date	2014/11/20
Test Mode	UNII Band 1/ IEEE 802.11ac VHT40 TX / CH Low / Internal Antenna	Temp. & Humidity	24.5°C, 33%

966 Chamber_B at 3Meter / Horizontal									
Frequency (MHz)	Reading-PK (dBuV)	Reading-AV (dBuV)	Correction Factor (dB/m)	Result-PK (dBuV/m)	Result-AV (dBuV/m)	Limit-PK (dBuV/m)	Limit-AV (dBuV/m)	Margin (dB)	Remark
1795.00	45.93	---	0.73	46.66	---	74.00	54.00	-7.34	Peak
3870.00	41.55	---	6.16	47.71	---	74.00	54.00	-6.29	Peak
4455.00	39.82	---	8.62	48.44	---	74.00	54.00	-5.56	Peak
5390.00	39.27	---	10.16	49.44	---	74.00	54.00	-4.56	Peak
6240.00	38.17	---	12.66	50.84	---	74.00	54.00	-3.16	Peak
7764.00	37.99	---	13.52	51.50	---	74.00	54.00	-2.50	Peak
8892.00	36.74	---	15.23	51.98	---	74.00	54.00	-2.02	Peak

966 Chamber_B at 3Meter / Vertical									
Frequency (MHz)	Reading-PK (dBuV)	Reading-AV (dBuV)	Correction Factor (dB/m)	Result-PK (dBuV/m)	Result-AV (dBuV/m)	Limit-PK (dBuV/m)	Limit-AV (dBuV/m)	Margin (dB)	Remark
3225.00	41.90	---	5.17	47.07	---	74.00	54.00	-6.93	Peak
3895.00	41.85	---	6.20	48.05	---	74.00	54.00	-5.95	Peak
4375.00	40.48	---	8.23	48.70	---	74.00	54.00	-5.30	Peak
5440.00	39.20	---	10.36	49.56	---	74.00	54.00	-4.44	Peak
6096.00	38.00	---	12.73	50.72	---	74.00	54.00	-3.28	Peak
8052.00	38.19	---	14.34	52.53	---	74.00	54.00	-1.47	Peak
8976.00	37.41	---	15.17	52.57	---	74.00	54.00	-1.43	Peak

Remark:

1. Measuring frequencies from 1 GHz to the 10th harmonic of highest fundamental frequency.
2. Average test would be performed if the peak result were greater than the average limit.
3. Data of measurement within this frequency range shown " --- " in the table above means the reading of emissions are attenuated more than 20dB below the permissible limits or the field strength is too small to be measured.
4. Measurements above show only up to 6 maximum emissions noted, or would be lesser, with " N/A " remark, if no specific emissions from the EUT are recorded (ie: margin>20dB from the applicable limit) and considered that's already beyond the background noise floor.
5. Result = Reading + Correction Factor
Margin = Result - Limit
Remark Peak = Result(PK) - Limit(AV)
Remark AVG = Result(AV) - Limit(AV)



Product Name	Panel PC	Test By	Davis Tseng
Test Model	VM-521	Test Date	2014/11/20
Test Mode	UNII Band 1/ IEEE 802.11ac VHT40 TX / CH High / Internal Antenna	Temp. & Humidity	24.5°C, 33%

966 Chamber_B at 3Meter / Horizontal

Frequency (MHz)	Reading-PK (dBuV)	Reading-AV (dBuV)	Correction Factor (dB/m)	Result-PK (dBuV/m)	Result-AV (dBuV/m)	Limit-PK (dBuV/m)	Limit-AV (dBuV/m)	Margin (dB)	Remark
3140.00	42.70	---	5.03	47.72	---	74.00	54.00	-6.28	Peak
4565.00	40.47	---	8.82	49.29	---	74.00	54.00	-4.71	Peak
4805.00	40.84	---	8.70	49.55	---	74.00	54.00	-4.45	Peak
5390.00	41.53	---	10.16	51.69	---	74.00	54.00	-2.31	Peak
6120.00	37.82	---	12.72	50.54	---	74.00	54.00	-3.46	Peak
7728.00	38.87	---	13.41	52.28	---	74.00	54.00	-1.72	Peak
8856.00	37.23	---	15.26	52.49	---	74.00	54.00	-1.51	Peak

966 Chamber_B at 3Meter / Vertical

Frequency (MHz)	Reading-PK (dBuV)	Reading-AV (dBuV)	Correction Factor (dB/m)	Result-PK (dBuV/m)	Result-AV (dBuV/m)	Limit-PK (dBuV/m)	Limit-AV (dBuV/m)	Margin (dB)	Remark
3015.00	41.91	---	4.82	46.73	---	74.00	54.00	-7.27	Peak
4390.00	40.34	---	8.30	48.64	---	74.00	54.00	-5.36	Peak
4640.00	40.25	---	8.78	49.03	---	74.00	54.00	-4.97	Peak
5420.00	39.49	---	10.28	49.77	---	74.00	54.00	-4.23	Peak
6012.00	38.06	---	12.76	50.82	---	74.00	54.00	-3.18	Peak
7812.00	38.20	---	13.65	51.85	---	74.00	54.00	-2.15	Peak
9216.00	36.77	---	15.50	52.27	---	74.00	54.00	-1.73	Peak

Remark:

1. Measuring frequencies from 1 GHz to the 10th harmonic of highest fundamental frequency.
2. Average test would be performed if the peak result were greater than the average limit.
3. Data of measurement within this frequency range shown " --- " in the table above means the reading of emissions are attenuated more than 20dB below the permissible limits or the field strength is too small to be measured.
4. Measurements above show only up to 6 maximum emissions noted, or would be lesser, with " N/A " remark, if no specific emissions from the EUT are recorded (ie: margin>20dB from the applicable limit) and considered that's already beyond the background noise floor.
5. Result = Reading + Correction Factor
Margin = Result - Limit
Remark Peak = Result(PK) - Limit(AV)
Remark AVG = Result(AV) - Limit(AV)



Product Name	Panel PC	Test By	Davis Tseng
Test Model	VM-521	Test Date	2014/11/20
Test Mode	UNII Band 1/ IEEE 802.11ac VHT80 TX / CH Low / Internal Antenna	Temp. & Humidity	24.5°C, 33%

966 Chamber_B at 3Meter / Horizontal

Frequency (MHz)	Reading-PK (dBuV)	Reading-AV (dBuV)	Correction Factor (dB/m)	Result-PK (dBuV/m)	Result-AV (dBuV/m)	Limit-PK (dBuV/m)	Limit-AV (dBuV/m)	Margin (dB)	Remark
1795.00	47.48	---	0.73	48.21	---	74.00	54.00	-5.79	Peak
3065.00	43.39	---	4.90	48.29	---	74.00	54.00	-5.71	Peak
4605.00	40.43	---	8.80	49.23	---	74.00	54.00	-4.77	Peak
5400.00	38.92	---	10.20	49.12	---	74.00	54.00	-4.88	Peak
6024.00	38.40	---	12.76	51.16	---	74.00	54.00	-2.84	Peak
7176.00	38.18	---	13.61	51.79	---	74.00	54.00	-2.21	Peak
7776.00	38.02	---	13.55	51.58	---	74.00	54.00	-2.42	Peak

966 Chamber_B at 3Meter / Vertical

Frequency (MHz)	Reading-PK (dBuV)	Reading-AV (dBuV)	Correction Factor (dB/m)	Result-PK (dBuV/m)	Result-AV (dBuV/m)	Limit-PK (dBuV/m)	Limit-AV (dBuV/m)	Margin (dB)	Remark
3210.00	42.37	---	5.14	47.51	---	74.00	54.00	-6.49	Peak
3665.00	41.81	---	5.87	47.68	---	74.00	54.00	-6.32	Peak
4615.00	40.35	---	8.79	49.15	---	74.00	54.00	-4.85	Peak
5445.00	38.96	---	10.38	49.34	---	74.00	54.00	-4.66	Peak
6156.00	38.95	---	12.70	51.65	---	74.00	54.00	-2.35	Peak
7380.00	38.54	---	13.07	51.61	---	74.00	54.00	-2.39	Peak
8184.00	37.50	---	14.69	52.19	---	74.00	54.00	-1.81	Peak

Remark:

1. Measuring frequencies from 1 GHz to the 10th harmonic of highest fundamental frequency.
2. Average test would be performed if the peak result were greater than the average limit.
3. Data of measurement within this frequency range shown " --- " in the table above means the reading of emissions are attenuated more than 20dB below the permissible limits or the field strength is too small to be measured.
4. Measurements above show only up to 6 maximum emissions noted, or would be lesser, with " N/A " remark, if no specific emissions from the EUT are recorded (ie: margin>20dB from the applicable limit) and considered that's already beyond the background noise floor.
5. Result = Reading + Correction Factor
Margin = Result - Limit
Remark Peak = Result(PK) - Limit(AV)
Remark AVG = Result(AV) - Limit(AV)



Product Name	Panel PC	Test By	Davis Tseng
Test Model	VM-521	Test Date	2014/11/20
Test Mode	UNII Band 2A / IEEE 802.11a TX / CH Low / Internal Antenna	Temp. & Humidity	24.5°C, 33%

966 Chamber_B at 3Meter / Horizontal									
Frequency (MHz)	Reading-PK (dBuV)	Reading-AV (dBuV)	Correction Factor (dB/m)	Result-PK (dBuV/m)	Result-AV (dBuV/m)	Limit-PK (dBuV/m)	Limit-AV (dBuV/m)	Margin (dB)	Remark
1665.00	44.17	---	-0.48	43.70	---	74.00	54.00	-10.30	Peak
3290.00	42.03	---	5.28	47.31	---	74.00	54.00	-6.69	Peak
4575.00	39.97	---	8.81	48.79	---	74.00	54.00	-5.21	Peak
4710.00	40.50	---	8.75	49.25	---	74.00	54.00	-4.75	Peak
6192.00	38.76	---	12.69	51.44	---	74.00	54.00	-2.56	Peak
7608.00	37.68	---	13.06	50.74	---	74.00	54.00	-3.26	Peak
9084.00	37.14	---	15.29	52.43	---	74.00	54.00	-1.57	Peak

966 Chamber_B at 3Meter / Vertical									
Frequency (MHz)	Reading-PK (dBuV)	Reading-AV (dBuV)	Correction Factor (dB/m)	Result-PK (dBuV/m)	Result-AV (dBuV/m)	Limit-PK (dBuV/m)	Limit-AV (dBuV/m)	Margin (dB)	Remark
2445.00	41.68	---	3.50	45.19	---	74.00	54.00	-8.81	Peak
3050.00	42.16	---	4.87	47.04	---	74.00	54.00	-6.96	Peak
4130.00	40.80	---	7.00	47.80	---	74.00	54.00	-6.20	Peak
4665.00	41.01	---	8.77	49.78	---	74.00	54.00	-4.22	Peak
6096.00	37.97	---	12.73	50.70	---	74.00	54.00	-3.30	Peak
7620.00	38.00	---	13.10	51.09	---	74.00	54.00	-2.91	Peak
9096.00	36.79	---	15.31	52.09	---	74.00	54.00	-1.91	Peak

Remark:

1. Measuring frequencies from 1 GHz to the 10th harmonic of highest fundamental frequency.
2. Average test would be performed if the peak result were greater than the average limit.
3. Data of measurement within this frequency range shown " --- " in the table above means the reading of emissions are attenuated more than 20dB below the permissible limits or the field strength is too small to be measured.
4. Measurements above show only up to 6 maximum emissions noted, or would be lesser, with " N/A " remark, if no specific emissions from the EUT are recorded (ie: margin>20dB from the applicable limit) and considered that's already beyond the background noise floor.
5. Result = Reading + Correction Factor
Margin = Result - Limit
Remark Peak = Result(PK) - Limit(AV)
Remark AVG = Result(AV) - Limit(AV)



Product Name	Panel PC	Test By	Davis Tseng
Test Model	VM-521	Test Date	2014/11/20
Test Mode	UNII Band 2A / IEEE 802.11a TX / CH Middle / Internal Antenna	Temp. & Humidity	24.5°C, 33%

966 Chamber_B at 3Meter / Horizontal									
Frequency (MHz)	Reading-PK (dBuV)	Reading-AV (dBuV)	Correction Factor (dB/m)	Result-PK (dBuV/m)	Result-AV (dBuV/m)	Limit-PK (dBuV/m)	Limit-AV (dBuV/m)	Margin (dB)	Remark
1665.00	45.29	---	-0.48	44.81	---	74.00	54.00	-9.19	Peak
3100.00	43.06	---	4.96	48.02	---	74.00	54.00	-5.98	Peak
3250.00	42.65	---	5.21	47.86	---	74.00	54.00	-6.14	Peak
4690.00	40.47	---	8.76	49.23	---	74.00	54.00	-4.77	Peak
6144.00	39.41	---	12.71	52.12	---	74.00	54.00	-1.88	Peak
7836.00	38.22	---	13.72	51.94	---	74.00	54.00	-2.06	Peak
9216.00	37.26	---	15.50	52.76	---	74.00	54.00	-1.24	Peak

966 Chamber_B at 3Meter / Vertical									
Frequency (MHz)	Reading-PK (dBuV)	Reading-AV (dBuV)	Correction Factor (dB/m)	Result-PK (dBuV/m)	Result-AV (dBuV/m)	Limit-PK (dBuV/m)	Limit-AV (dBuV/m)	Margin (dB)	Remark
2305.00	43.22	---	3.23	46.45	---	74.00	54.00	-7.55	Peak
3645.00	41.22	---	5.84	47.06	---	74.00	54.00	-6.94	Peak
4605.00	40.77	---	8.80	49.57	---	74.00	54.00	-4.43	Peak
4760.00	40.17	---	8.73	48.89	---	74.00	54.00	-5.11	Peak
6120.00	38.06	---	12.72	50.77	---	74.00	54.00	-3.23	Peak
7764.00	38.14	---	13.52	51.65	---	74.00	54.00	-2.35	Peak
9072.00	37.07	---	15.27	52.33	---	74.00	54.00	-1.67	Peak

Remark:

1. Measuring frequencies from 1 GHz to the 10th harmonic of highest fundamental frequency.
2. Average test would be performed if the peak result were greater than the average limit.
3. Data of measurement within this frequency range shown " --- " in the table above means the reading of emissions are attenuated more than 20dB below the permissible limits or the field strength is too small to be measured.
4. Measurements above show only up to 6 maximum emissions noted, or would be lesser, with " N/A " remark, if no specific emissions from the EUT are recorded (ie: margin>20dB from the applicable limit) and considered that's already beyond the background noise floor.
5. Result = Reading + Correction Factor
Margin = Result - Limit
Remark Peak = Result(PK) - Limit(AV)
Remark AVG = Result(AV) - Limit(AV)



Product Name	Panel PC	Test By	Davis Tseng
Test Model	VM-521	Test Date	2014/11/20
Test Mode	UNII Band 2A / IEEE 802.11a TX / CH High / Internal Antenna	Temp. & Humidity	24.5°C, 33%

966 Chamber_B at 3Meter / Horizontal									
Frequency (MHz)	Reading-PK (dBuV)	Reading-AV (dBuV)	Correction Factor (dB/m)	Result-PK (dBuV/m)	Result-AV (dBuV/m)	Limit-PK (dBuV/m)	Limit-AV (dBuV/m)	Margin (dB)	Remark
1665.00	47.24	---	-0.48	46.76	---	74.00	54.00	-7.24	Peak
3320.00	42.19	---	5.33	47.52	---	74.00	54.00	-6.48	Peak
4450.00	39.98	---	8.60	48.58	---	74.00	54.00	-5.42	Peak
4680.00	40.21	---	8.76	48.98	---	74.00	54.00	-5.02	Peak
6156.00	38.49	---	12.70	51.20	---	74.00	54.00	-2.80	Peak
7620.00	37.71	---	13.10	50.81	---	74.00	54.00	-3.19	Peak
9012.00	36.45	---	15.17	51.62	---	74.00	54.00	-2.38	Peak

966 Chamber_B at 3Meter / Vertical									
Frequency (MHz)	Reading-PK (dBuV)	Reading-AV (dBuV)	Correction Factor (dB/m)	Result-PK (dBuV/m)	Result-AV (dBuV/m)	Limit-PK (dBuV/m)	Limit-AV (dBuV/m)	Margin (dB)	Remark
1810.00	43.07	---	0.87	43.94	---	74.00	54.00	-10.06	Peak
3185.00	41.91	---	5.10	47.01	---	74.00	54.00	-6.99	Peak
3630.00	42.02	---	5.82	47.84	---	74.00	54.00	-6.16	Peak
4600.00	40.41	---	8.80	49.21	---	74.00	54.00	-4.79	Peak
6204.00	38.77	---	12.68	51.45	---	74.00	54.00	-2.55	Peak
7812.00	38.31	---	13.65	51.97	---	74.00	54.00	-2.03	Peak
9156.00	37.18	---	15.40	52.58	---	74.00	54.00	-1.42	Peak

Remark:

1. Measuring frequencies from 1 GHz to the 10th harmonic of highest fundamental frequency.
2. Average test would be performed if the peak result were greater than the average limit.
3. Data of measurement within this frequency range shown " --- " in the table above means the reading of emissions are attenuated more than 20dB below the permissible limits or the field strength is too small to be measured.
4. Measurements above show only up to 6 maximum emissions noted, or would be lesser, with " N/A " remark, if no specific emissions from the EUT are recorded (ie: margin>20dB from the applicable limit) and considered that's already beyond the background noise floor.
5. Result = Reading + Correction Factor
Margin = Result - Limit
Remark Peak = Result(PK) - Limit(AV)
Remark AVG = Result(AV) - Limit(AV)



Product Name	Panel PC	Test By	Davis Tseng
Test Model	VM-521	Test Date	2014/11/20
Test Mode	UNII Band 2A / IEEE 802.11ac VHT20 TX / CH Low / Internal Antenna	Temp. & Humidity	24.5°C, 33%

966 Chamber_B at 3Meter / Horizontal									
Frequency (MHz)	Reading-PK (dBuV)	Reading-AV (dBuV)	Correction Factor (dB/m)	Result-PK (dBuV/m)	Result-AV (dBuV/m)	Limit-PK (dBuV/m)	Limit-AV (dBuV/m)	Margin (dB)	Remark
1600.00	46.88	---	-1.08	45.80	---	74.00	54.00	-8.20	Peak
3110.00	41.72	---	4.97	46.70	---	74.00	54.00	-7.30	Peak
4570.00	40.54	---	8.82	49.36	---	74.00	54.00	-4.64	Peak
4700.00	40.40	---	8.75	49.15	---	74.00	54.00	-4.85	Peak
6108.00	38.05	---	12.72	50.77	---	74.00	54.00	-3.23	Peak
7320.00	38.78	---	13.23	52.00	---	74.00	54.00	-2.00	Peak
8160.00	36.97	---	14.63	51.60	---	74.00	54.00	-2.40	Peak

966 Chamber_B at 3Meter / Vertical									
Frequency (MHz)	Reading-PK (dBuV)	Reading-AV (dBuV)	Correction Factor (dB/m)	Result-PK (dBuV/m)	Result-AV (dBuV/m)	Limit-PK (dBuV/m)	Limit-AV (dBuV/m)	Margin (dB)	Remark
2480.00	41.82	---	3.57	45.39	---	74.00	54.00	-8.61	Peak
3190.00	42.61	---	5.11	47.72	---	74.00	54.00	-6.28	Peak
4575.00	39.95	---	8.81	48.76	---	74.00	54.00	-5.24	Peak
4705.00	40.39	---	8.75	49.14	---	74.00	54.00	-4.86	Peak
6228.00	38.43	---	12.67	51.10	---	74.00	54.00	-2.90	Peak
7356.00	38.47	---	13.13	51.60	---	74.00	54.00	-2.40	Peak
8916.00	35.48	---	15.21	50.69	---	74.00	54.00	-3.31	Peak

Remark:

1. Measuring frequencies from 1 GHz to the 10th harmonic of highest fundamental frequency.
2. Average test would be performed if the peak result were greater than the average limit.
3. Data of measurement within this frequency range shown " --- " in the table above means the reading of emissions are attenuated more than 20dB below the permissible limits or the field strength is too small to be measured.
4. Measurements above show only up to 6 maximum emissions noted, or would be lesser, with " N/A " remark, if no specific emissions from the EUT are recorded (ie: margin>20dB from the applicable limit) and considered that's already beyond the background noise floor.
5. Result = Reading + Correction Factor
Margin = Result - Limit
Remark Peak = Result(PK) - Limit(AV)
Remark AVG = Result(AV) - Limit(AV)



Product Name	Panel PC	Test By	Davis Tseng
Test Model	VM-521	Test Date	2014/11/20
Test Mode	UNII Band 2A / IEEE 802.11ac VHT20 TX / CH Middle / Internal Antenna	Temp. & Humidity	24.5°C, 33%

966 Chamber_B at 3Meter / Horizontal									
Frequency (MHz)	Reading-PK (dBuV)	Reading-AV (dBuV)	Correction Factor (dB/m)	Result-PK (dBuV/m)	Result-AV (dBuV/m)	Limit-PK (dBuV/m)	Limit-AV (dBuV/m)	Margin (dB)	Remark
1715.00	44.71	---	-0.01	44.70	---	74.00	54.00	-9.30	Peak
3200.00	42.33	---	5.13	47.46	---	74.00	54.00	-6.54	Peak
4515.00	40.48	---	8.84	49.32	---	74.00	54.00	-4.68	Peak
4655.00	41.17	---	8.78	49.95	---	74.00	54.00	-4.05	Peak
6168.00	38.19	---	12.70	50.89	---	74.00	54.00	-3.11	Peak
7464.00	38.99	---	12.85	51.84	---	74.00	54.00	-2.16	Peak
8916.00	36.46	---	15.21	51.68	---	74.00	54.00	-2.32	Peak

966 Chamber_B at 3Meter / Vertical									
Frequency (MHz)	Reading-PK (dBuV)	Reading-AV (dBuV)	Correction Factor (dB/m)	Result-PK (dBuV/m)	Result-AV (dBuV/m)	Limit-PK (dBuV/m)	Limit-AV (dBuV/m)	Margin (dB)	Remark
2400.00	42.62	---	3.41	46.03	---	74.00	54.00	-7.97	Peak
3095.00	43.00	---	4.95	47.95	---	74.00	54.00	-6.05	Peak
3875.00	41.98	---	6.17	48.15	---	74.00	54.00	-5.85	Peak
4620.00	40.54	---	8.79	49.33	---	74.00	54.00	-4.67	Peak
6024.00	37.77	---	12.76	50.53	---	74.00	54.00	-3.47	Peak
7680.00	37.88	---	13.27	51.15	---	74.00	54.00	-2.85	Peak
9060.00	36.80	---	15.25	52.04	---	74.00	54.00	-1.96	Peak

Remark:

1. Measuring frequencies from 1 GHz to the 10th harmonic of highest fundamental frequency.
2. Average test would be performed if the peak result were greater than the average limit.
3. Data of measurement within this frequency range shown " --- " in the table above means the reading of emissions are attenuated more than 20dB below the permissible limits or the field strength is too small to be measured.
4. Measurements above show only up to 6 maximum emissions noted, or would be lesser, with " N/A " remark, if no specific emissions from the EUT are recorded (ie: margin>20dB from the applicable limit) and considered that's already beyond the background noise floor.
5. Result = Reading + Correction Factor
Margin = Result - Limit
Remark Peak = Result(PK) - Limit(AV)
Remark AVG = Result(AV) - Limit(AV)



Product Name	Panel PC	Test By	Davis Tseng
Test Model	VM-521	Test Date	2014/11/20
Test Mode	UNII Band 2A / IEEE 802.11ac VHT20 TX / CH High / Internal Antenna	Temp. & Humidity	24.5°C, 33%

966 Chamber_B at 3Meter / Horizontal									
Frequency (MHz)	Reading-PK (dBuV)	Reading-AV (dBuV)	Correction Factor (dB/m)	Result-PK (dBuV/m)	Result-AV (dBuV/m)	Limit-PK (dBuV/m)	Limit-AV (dBuV/m)	Margin (dB)	Remark
1665.00	46.63	---	-0.48	46.15	---	74.00	54.00	-7.85	Peak
3905.00	42.22	---	6.21	48.43	---	74.00	54.00	-5.57	Peak
4560.00	40.34	---	8.82	49.16	---	74.00	54.00	-4.84	Peak
4830.00	40.19	---	8.69	48.88	---	74.00	54.00	-5.12	Peak
6180.00	38.32	---	12.69	51.01	---	74.00	54.00	-2.99	Peak
7044.00	38.43	---	13.95	52.38	---	74.00	54.00	-1.62	Peak
8040.00	37.25	---	14.31	51.56	---	74.00	54.00	-2.44	Peak

966 Chamber_B at 3Meter / Vertical									
Frequency (MHz)	Reading-PK (dBuV)	Reading-AV (dBuV)	Correction Factor (dB/m)	Result-PK (dBuV/m)	Result-AV (dBuV/m)	Limit-PK (dBuV/m)	Limit-AV (dBuV/m)	Margin (dB)	Remark
2890.00	42.33	---	4.53	46.86	---	74.00	54.00	-7.14	Peak
3095.00	42.15	---	4.95	47.10	---	74.00	54.00	-6.90	Peak
4465.00	40.36	---	8.68	49.04	---	74.00	54.00	-4.96	Peak
4705.00	40.51	---	8.75	49.26	---	74.00	54.00	-4.74	Peak
6036.00	38.78	---	12.75	51.53	---	74.00	54.00	-2.47	Peak
7524.00	38.89	---	12.82	51.71	---	74.00	54.00	-2.29	Peak
9072.00	37.08	---	15.27	52.35	---	74.00	54.00	-1.65	Peak

Remark:

1. Measuring frequencies from 1 GHz to the 10th harmonic of highest fundamental frequency.
2. Average test would be performed if the peak result were greater than the average limit.
3. Data of measurement within this frequency range shown " --- " in the table above means the reading of emissions are attenuated more than 20dB below the permissible limits or the field strength is too small to be measured.
4. Measurements above show only up to 6 maximum emissions noted, or would be lesser, with " N/A " remark, if no specific emissions from the EUT are recorded (ie: margin>20dB from the applicable limit) and considered that's already beyond the background noise floor.
5. Result = Reading + Correction Factor
Margin = Result - Limit
Remark Peak = Result(PK) - Limit(AV)
Remark AVG = Result(AV) - Limit(AV)



Product Name	Panel PC	Test By	Davis Tseng
Test Model	VM-521	Test Date	2014/11/20
Test Mode	UNII Band 2A / IEEE 802.11ac VHT40 TX / CH Low / Internal Antenna	Temp. & Humidity	24.5°C, 33%

966 Chamber_B at 3Meter / Horizontal									
Frequency (MHz)	Reading-PK (dBuV)	Reading-AV (dBuV)	Correction Factor (dB/m)	Result-PK (dBuV/m)	Result-AV (dBuV/m)	Limit-PK (dBuV/m)	Limit-AV (dBuV/m)	Margin (dB)	Remark
2195.00	42.98	---	3.01	45.99	---	74.00	54.00	-8.01	Peak
3090.00	42.23	---	4.94	47.17	---	74.00	54.00	-6.83	Peak
4485.00	40.38	---	8.78	49.16	---	74.00	54.00	-4.84	Peak
4670.00	40.16	---	8.77	48.93	---	74.00	54.00	-5.07	Peak
6204.00	37.73	---	12.68	50.41	---	74.00	54.00	-3.59	Peak
7752.00	38.52	---	13.48	52.00	---	74.00	54.00	-2.00	Peak
8892.00	36.60	---	15.23	51.83	---	74.00	54.00	-2.17	Peak

966 Chamber_B at 3Meter / Vertical									
Frequency (MHz)	Reading-PK (dBuV)	Reading-AV (dBuV)	Correction Factor (dB/m)	Result-PK (dBuV/m)	Result-AV (dBuV/m)	Limit-PK (dBuV/m)	Limit-AV (dBuV/m)	Margin (dB)	Remark
1955.00	44.28	---	2.21	46.49	---	74.00	54.00	-7.51	Peak
3245.00	41.80	---	5.20	47.00	---	74.00	54.00	-7.00	Peak
4455.00	40.98	---	8.62	49.61	---	74.00	54.00	-4.39	Peak
4680.00	41.28	---	8.76	50.05	---	74.00	54.00	-3.95	Peak
6216.00	37.79	---	12.67	50.46	---	74.00	54.00	-3.54	Peak
7704.00	38.23	---	13.34	51.57	---	74.00	54.00	-2.43	Peak
9072.00	35.84	---	15.27	51.10	---	74.00	54.00	-2.90	Peak

Remark:

1. Measuring frequencies from 1 GHz to the 10th harmonic of highest fundamental frequency.
2. Average test would be performed if the peak result were greater than the average limit.
3. Data of measurement within this frequency range shown " --- " in the table above means the reading of emissions are attenuated more than 20dB below the permissible limits or the field strength is too small to be measured.
4. Measurements above show only up to 6 maximum emissions noted, or would be lesser, with " N/A " remark, if no specific emissions from the EUT are recorded (ie: margin>20dB from the applicable limit) and considered that's already beyond the background noise floor.
5. Result = Reading + Correction Factor
Margin = Result - Limit
Remark Peak = Result(PK) - Limit(AV)
Remark AVG = Result(AV) - Limit(AV)



Product Name	Panel PC	Test By	Davis Tseng
Test Model	VM-521	Test Date	2014/11/20
Test Mode	UNII Band 2A / IEEE 802.11ac VHT40 TX / CH High / Internal Antenna	Temp. & Humidity	24.5°C, 33%

966 Chamber_B at 3Meter / Horizontal									
Frequency (MHz)	Reading-PK (dBuV)	Reading-AV (dBuV)	Correction Factor (dB/m)	Result-PK (dBuV/m)	Result-AV (dBuV/m)	Limit-PK (dBuV/m)	Limit-AV (dBuV/m)	Margin (dB)	Remark
1685.00	46.42	---	-0.29	46.13	---	74.00	54.00	-7.87	Peak
3235.00	42.33	---	5.18	47.52	---	74.00	54.00	-6.48	Peak
4445.00	40.07	---	8.58	48.65	---	74.00	54.00	-5.35	Peak
4690.00	40.05	---	8.76	48.81	---	74.00	54.00	-5.19	Peak
6060.00	38.51	---	12.74	51.25	---	74.00	54.00	-2.75	Peak
7392.00	38.30	---	13.04	51.34	---	74.00	54.00	-2.66	Peak
8892.00	37.33	---	15.23	52.57	---	74.00	54.00	-1.43	Peak

966 Chamber_B at 3Meter / Vertical									
Frequency (MHz)	Reading-PK (dBuV)	Reading-AV (dBuV)	Correction Factor (dB/m)	Result-PK (dBuV/m)	Result-AV (dBuV/m)	Limit-PK (dBuV/m)	Limit-AV (dBuV/m)	Margin (dB)	Remark
3095.00	42.50	---	4.95	47.45	---	74.00	54.00	-6.55	Peak
3845.00	41.63	---	6.13	47.76	---	74.00	54.00	-6.24	Peak
4510.00	40.36	---	8.85	49.21	---	74.00	54.00	-4.79	Peak
4710.00	40.11	---	8.75	48.86	---	74.00	54.00	-5.14	Peak
6216.00	38.20	---	12.67	50.87	---	74.00	54.00	-3.13	Peak
7728.00	37.89	---	13.41	51.30	---	74.00	54.00	-2.70	Peak
8952.00	36.79	---	15.19	51.97	---	74.00	54.00	-2.03	Peak

Remark:

1. Measuring frequencies from 1 GHz to the 10th harmonic of highest fundamental frequency.
2. Average test would be performed if the peak result were greater than the average limit.
3. Data of measurement within this frequency range shown " --- " in the table above means the reading of emissions are attenuated more than 20dB below the permissible limits or the field strength is too small to be measured.
4. Measurements above show only up to 6 maximum emissions noted, or would be lesser, with " N/A " remark, if no specific emissions from the EUT are recorded (ie: margin>20dB from the applicable limit) and considered that's already beyond the background noise floor.
5. Result = Reading + Correction Factor
Margin = Result - Limit
Remark Peak = Result(PK) - Limit(AV)
Remark AVG = Result(AV) - Limit(AV)



Product Name	Panel PC	Test By	Davis Tseng
Test Model	VM-521	Test Date	2014/11/20
Test Mode	UNII Band 2A / IEEE 802.11ac VHT80 TX / CH Low / Internal Antenna	Temp. & Humidity	24.5°C, 33%

966 Chamber_B at 3Meter / Horizontal									
Frequency (MHz)	Reading-PK (dBuV)	Reading-AV (dBuV)	Correction Factor (dB/m)	Result-PK (dBuV/m)	Result-AV (dBuV/m)	Limit-PK (dBuV/m)	Limit-AV (dBuV/m)	Margin (dB)	Remark
1705.00	45.73	---	-0.11	45.63	---	74.00	54.00	-8.37	Peak
3140.00	42.60	---	5.03	47.63	---	74.00	54.00	-6.37	Peak
4625.00	41.00	---	8.79	49.79	---	74.00	54.00	-4.21	Peak
6120.00	38.61	---	12.72	51.33	---	74.00	54.00	-2.67	Peak
6804.00	38.21	---	13.47	51.68	---	74.00	54.00	-2.32	Peak
7788.00	38.51	---	13.59	52.09	---	74.00	54.00	-1.91	Peak

966 Chamber_B at 3Meter / Vertical									
Frequency (MHz)	Reading-PK (dBuV)	Reading-AV (dBuV)	Correction Factor (dB/m)	Result-PK (dBuV/m)	Result-AV (dBuV/m)	Limit-PK (dBuV/m)	Limit-AV (dBuV/m)	Margin (dB)	Remark
2280.00	42.73	---	3.18	45.91	---	74.00	54.00	-8.09	Peak
4095.00	40.94	---	6.82	47.77	---	74.00	54.00	-6.23	Peak
4560.00	40.87	---	8.82	49.69	---	74.00	54.00	-4.31	Peak
4710.00	41.04	---	8.75	49.79	---	74.00	54.00	-4.21	Peak
6036.00	38.81	---	12.75	51.57	---	74.00	54.00	-2.43	Peak
7308.00	38.46	---	13.26	51.72	---	74.00	54.00	-2.28	Peak
8220.00	37.30	---	14.79	52.08	---	74.00	54.00	-1.92	Peak

Remark:

1. Measuring frequencies from 1 GHz to the 10th harmonic of highest fundamental frequency.
2. Average test would be performed if the peak result were greater than the average limit.
3. Data of measurement within this frequency range shown " --- " in the table above means the reading of emissions are attenuated more than 20dB below the permissible limits or the field strength is too small to be measured.
4. Measurements above show only up to 6 maximum emissions noted, or would be lesser, with " N/A " remark, if no specific emissions from the EUT are recorded (ie: margin>20dB from the applicable limit) and considered that's already beyond the background noise floor.
5. Result = Reading + Correction Factor
Margin = Result - Limit
Remark Peak = Result(PK) - Limit(AV)
Remark AVG = Result(AV) - Limit(AV)



Product Name	Panel PC	Test By	Rex Chiu
Test Model	VM-521	Test Date	2014/11/19
Test Mode	UNII Band 2C / IEEE 802.11a TX / CH Low / Internal Antenna	Temp. & Humidity	21°C, 56%

966 Chamber_B at 3Meter / Horizontal									
Frequency (MHz)	Reading-PK (dBuV)	Reading-AV (dBuV)	Correction Factor (dB/m)	Result-PK (dBuV/m)	Result-AV (dBuV/m)	Limit-PK (dBuV/m)	Limit-AV (dBuV/m)	Margin (dB)	Remark
3825.00	43.09	---	6.10	49.19	---	74.00	54.00	-4.81	Peak
4675.00	42.58	---	8.77	51.34	---	74.00	54.00	-2.66	Peak
5985.00	39.70	---	12.70	52.40	---	74.00	54.00	-1.60	Peak
6108.00	38.29	---	12.72	51.01	---	74.00	54.00	-2.99	Peak
7284.00	37.89	---	13.32	51.21	---	74.00	54.00	-2.79	Peak
8928.00	36.69	---	15.20	51.90	---	74.00	54.00	-2.10	Peak

966 Chamber_B at 3Meter / Vertical									
Frequency (MHz)	Reading-PK (dBuV)	Reading-AV (dBuV)	Correction Factor (dB/m)	Result-PK (dBuV/m)	Result-AV (dBuV/m)	Limit-PK (dBuV/m)	Limit-AV (dBuV/m)	Margin (dB)	Remark
3290.00	43.65	---	5.28	48.93	---	74.00	54.00	-5.07	Peak
4735.00	41.99	---	8.74	50.73	---	74.00	54.00	-3.27	Peak
5965.00	39.31	---	12.62	51.93	---	74.00	54.00	-2.07	Peak
6060.00	37.95	---	12.74	50.69	---	74.00	54.00	-3.31	Peak
7560.00	38.13	---	12.92	51.05	---	74.00	54.00	-2.95	Peak
8868.00	36.34	---	15.25	51.59	---	74.00	54.00	-2.41	Peak

Remark:

1. Measuring frequencies from 1 GHz to the 10th harmonic of highest fundamental frequency.
2. Average test would be performed if the peak result were greater than the average limit.
3. Data of measurement within this frequency range shown " --- " in the table above means the reading of emissions are attenuated more than 20dB below the permissible limits or the field strength is too small to be measured.
4. Measurements above show only up to 6 maximum emissions noted, or would be lesser, with " N/A " remark, if no specific emissions from the EUT are recorded (ie: margin>20dB from the applicable limit) and considered that's already beyond the background noise floor.
5. Result = Reading + Correction Factor
Margin = Result - Limit
Remark Peak = Result(PK) - Limit(AV)
Remark AVG = Result(AV) - Limit(AV)



Product Name	Panel PC	Test By	Rex Chiu
Test Model	VM-521	Test Date	2014/11/19
Test Mode	UNII Band 2C / IEEE 802.11a TX / CH Middle / Internal Antenna	Temp. & Humidity	21°C, 56%

966 Chamber_B at 3Meter / Horizontal									
Frequency (MHz)	Reading-PK (dBuV)	Reading-AV (dBuV)	Correction Factor (dB/m)	Result-PK (dBuV/m)	Result-AV (dBuV/m)	Limit-PK (dBuV/m)	Limit-AV (dBuV/m)	Margin (dB)	Remark
3310.00	44.11	---	5.31	49.42	---	74.00	54.00	-4.58	Peak
4595.00	41.60	---	8.80	50.41	---	74.00	54.00	-3.59	Peak
5455.00	41.34	---	10.42	51.77	---	74.00	54.00	-2.23	Peak
6180.00	38.12	---	12.69	50.81	---	74.00	54.00	-3.19	Peak
7728.00	37.80	---	13.41	51.21	---	74.00	54.00	-2.79	Peak
8976.00	36.79	---	15.17	51.96	---	74.00	54.00	-2.04	Peak

966 Chamber_B at 3Meter / Vertical									
Frequency (MHz)	Reading-PK (dBuV)	Reading-AV (dBuV)	Correction Factor (dB/m)	Result-PK (dBuV/m)	Result-AV (dBuV/m)	Limit-PK (dBuV/m)	Limit-AV (dBuV/m)	Margin (dB)	Remark
4685.00	42.40	---	8.76	51.16	---	74.00	54.00	-2.84	Peak
5430.00	40.02	---	10.32	50.35	---	74.00	54.00	-3.65	Peak
5870.00	39.50	---	12.21	51.70	---	74.00	54.00	-2.30	Peak
6060.00	38.42	---	12.74	51.17	---	74.00	54.00	-2.83	Peak
7608.00	37.38	---	13.06	50.44	---	74.00	54.00	-3.56	Peak
8928.00	36.73	---	15.20	51.93	---	74.00	54.00	-2.07	Peak

Remark:

1. Measuring frequencies from 1 GHz to the 10th harmonic of highest fundamental frequency.
2. Average test would be performed if the peak result were greater than the average limit.
3. Data of measurement within this frequency range shown " --- " in the table above means the reading of emissions are attenuated more than 20dB below the permissible limits or the field strength is too small to be measured.
4. Measurements above show only up to 6 maximum emissions noted, or would be lesser, with " N/A " remark, if no specific emissions from the EUT are recorded (ie: margin>20dB from the applicable limit) and considered that's already beyond the background noise floor.
5. Result = Reading + Correction Factor
Margin = Result - Limit
Remark Peak = Result(PK) - Limit(AV)
Remark AVG = Result(AV) - Limit(AV)



Product Name	Panel PC	Test By	Rex Chiu
Test Model	VM-521	Test Date	2014/11/19
Test Mode	UNII Band 2C / IEEE 802.11a TX / CH High / Internal Antenna	Temp. & Humidity	21°C, 56%

966 Chamber_B at 3Meter / Horizontal									
Frequency (MHz)	Reading-PK (dBuV)	Reading-AV (dBuV)	Correction Factor (dB/m)	Result-PK (dBuV/m)	Result-AV (dBuV/m)	Limit-PK (dBuV/m)	Limit-AV (dBuV/m)	Margin (dB)	Remark
4665.00	42.40	---	8.77	51.18	---	74.00	54.00	-2.82	Peak
5390.00	40.25	---	10.16	50.42	---	74.00	54.00	-3.58	Peak
5985.00	39.59	---	12.70	52.29	---	74.00	54.00	-1.71	Peak
6036.00	38.15	---	12.75	50.90	---	74.00	54.00	-3.10	Peak
7632.00	38.61	---	13.13	51.75	---	74.00	54.00	-2.25	Peak
9036.00	37.00	---	15.21	52.21	---	74.00	54.00	-1.79	Peak

966 Chamber_B at 3Meter / Vertical									
Frequency (MHz)	Reading-PK (dBuV)	Reading-AV (dBuV)	Correction Factor (dB/m)	Result-PK (dBuV/m)	Result-AV (dBuV/m)	Limit-PK (dBuV/m)	Limit-AV (dBuV/m)	Margin (dB)	Remark
4685.00	42.14	---	8.76	50.90	---	74.00	54.00	-3.10	Peak
5450.00	40.14	---	10.40	50.54	---	74.00	54.00	-3.46	Peak
5985.00	39.84	---	12.70	52.54	---	74.00	54.00	-1.46	Peak
6060.00	37.95	---	12.74	50.70	---	74.00	54.00	-3.30	Peak
7476.00	38.30	---	12.81	51.11	---	74.00	54.00	-2.89	Peak
9096.00	37.15	---	15.31	52.46	---	74.00	54.00	-1.54	Peak

Remark:

1. Measuring frequencies from 1 GHz to the 10th harmonic of highest fundamental frequency.
2. Average test would be performed if the peak result were greater than the average limit.
3. Data of measurement within this frequency range shown " --- " in the table above means the reading of emissions are attenuated more than 20dB below the permissible limits or the field strength is too small to be measured.
4. Measurements above show only up to 6 maximum emissions noted, or would be lesser, with " N/A " remark, if no specific emissions from the EUT are recorded (ie: margin>20dB from the applicable limit) and considered that's already beyond the background noise floor.
5. Result = Reading + Correction Factor
Margin = Result - Limit
Remark Peak = Result(PK) - Limit(AV)
Remark AVG = Result(AV) - Limit(AV)



Product Name	Panel PC	Test By	Rex Chiu
Test Model	VM-521	Test Date	2014/11/19
Test Mode	UNII Band 2C / IEEE 802.11ac VHT20 TX / CH Low / Internal Antenna	Temp. & Humidity	21°C, 56%

966 Chamber_B at 3Meter / Horizontal									
Frequency (MHz)	Reading-PK (dBuV)	Reading-AV (dBuV)	Correction Factor (dB/m)	Result-PK (dBuV/m)	Result-AV (dBuV/m)	Limit-PK (dBuV/m)	Limit-AV (dBuV/m)	Margin (dB)	Remark
3270.00	43.47	---	5.24	48.71	---	74.00	54.00	-5.29	Peak
4700.00	41.54	---	8.75	50.30	---	74.00	54.00	-3.70	Peak
5975.00	39.90	---	12.66	52.57	---	74.00	54.00	-1.43	Peak
6084.00	37.84	---	12.73	50.57	---	74.00	54.00	-3.43	Peak
7872.00	37.42	---	13.83	51.24	---	74.00	54.00	-2.76	Peak
8868.00	36.91	---	15.25	52.16	---	74.00	54.00	-1.84	Peak

966 Chamber_B at 3Meter / Vertical									
Frequency (MHz)	Reading-PK (dBuV)	Reading-AV (dBuV)	Correction Factor (dB/m)	Result-PK (dBuV/m)	Result-AV (dBuV/m)	Limit-PK (dBuV/m)	Limit-AV (dBuV/m)	Margin (dB)	Remark
3850.00	43.03	---	6.13	49.16	---	74.00	54.00	-4.84	Peak
4650.00	41.80	---	8.78	50.58	---	74.00	54.00	-3.42	Peak
5965.00	39.73	---	12.62	52.35	---	74.00	54.00	-1.65	Peak
6012.00	38.01	---	12.76	50.78	---	74.00	54.00	-3.22	Peak
7464.00	37.99	---	12.85	50.83	---	74.00	54.00	-3.17	Peak
8892.00	36.81	---	15.23	52.04	---	74.00	54.00	-1.96	Peak

Remark:

1. Measuring frequencies from 1 GHz to the 10th harmonic of highest fundamental frequency.
2. Average test would be performed if the peak result were greater than the average limit.
3. Data of measurement within this frequency range shown " --- " in the table above means the reading of emissions are attenuated more than 20dB below the permissible limits or the field strength is too small to be measured.
4. Measurements above show only up to 6 maximum emissions noted, or would be lesser, with " N/A " remark, if no specific emissions from the EUT are recorded (ie: margin>20dB from the applicable limit) and considered that's already beyond the background noise floor.
5. Result = Reading + Correction Factor
Margin = Result - Limit
Remark Peak = Result(PK) - Limit(AV)
Remark AVG = Result(AV) - Limit(AV)



Product Name	Panel PC	Test By	Rex Chiu
Test Model	VM-521	Test Date	2014/11/19
Test Mode	UNII Band 2C / IEEE 802.11ac VHT20 TX / CH Middle / Internal Antenna	Temp. & Humidity	21°C, 56%

966 Chamber_B at 3Meter / Horizontal									
Frequency (MHz)	Reading-PK (dBuV)	Reading-AV (dBuV)	Correction Factor (dB/m)	Result-PK (dBuV/m)	Result-AV (dBuV/m)	Limit-PK (dBuV/m)	Limit-AV (dBuV/m)	Margin (dB)	Remark
4695.00	42.21	---	8.76	50.96	---	74.00	54.00	-3.04	Peak
5350.00	41.21	---	10.00	51.21	---	74.00	54.00	-2.79	Peak
5975.00	39.68	---	12.66	52.34	---	74.00	54.00	-1.66	Peak
6120.00	37.65	---	12.72	50.37	---	74.00	54.00	-3.63	Peak
7404.00	38.10	---	13.00	51.11	---	74.00	54.00	-2.89	Peak
8988.00	36.82	---	15.16	51.98	---	74.00	54.00	-2.02	Peak

966 Chamber_B at 3Meter / Vertical									
Frequency (MHz)	Reading-PK (dBuV)	Reading-AV (dBuV)	Correction Factor (dB/m)	Result-PK (dBuV/m)	Result-AV (dBuV/m)	Limit-PK (dBuV/m)	Limit-AV (dBuV/m)	Margin (dB)	Remark
3235.00	43.18	---	5.18	48.37	---	74.00	54.00	-5.63	Peak
4535.00	41.89	---	8.83	50.73	---	74.00	54.00	-3.27	Peak
5425.00	40.11	---	10.30	50.42	---	74.00	54.00	-3.58	Peak
6180.00	37.47	---	12.69	50.17	---	74.00	54.00	-3.83	Peak
7620.00	37.23	---	13.10	50.33	---	74.00	54.00	-3.67	Peak
8976.00	36.10	---	15.17	51.26	---	74.00	54.00	-2.74	Peak

Remark:

1. Measuring frequencies from 1 GHz to the 10th harmonic of highest fundamental frequency.
2. Average test would be performed if the peak result were greater than the average limit.
3. Data of measurement within this frequency range shown " --- " in the table above means the reading of emissions are attenuated more than 20dB below the permissible limits or the field strength is too small to be measured.
4. Measurements above show only up to 6 maximum emissions noted, or would be lesser, with " N/A " remark, if no specific emissions from the EUT are recorded (ie: margin>20dB from the applicable limit) and considered that's already beyond the background noise floor.
5. Result = Reading + Correction Factor
Margin = Result - Limit
Remark Peak = Result(PK) - Limit(AV)
Remark AVG = Result(AV) - Limit(AV)



Product Name	Panel PC	Test By	Rex Chiu
Test Model	VM-521	Test Date	2014/11/19
Test Mode	UNII Band 2C / IEEE 802.11ac VHT20 TX / CH High / Internal Antenna	Temp. & Humidity	21°C, 56%

966 Chamber_B at 3Meter / Horizontal									
Frequency (MHz)	Reading-PK (dBuV)	Reading-AV (dBuV)	Correction Factor (dB/m)	Result-PK (dBuV/m)	Result-AV (dBuV/m)	Limit-PK (dBuV/m)	Limit-AV (dBuV/m)	Margin (dB)	Remark
3205.00	42.89	---	5.13	48.03	---	74.00	54.00	-5.97	Peak
4795.00	42.07	---	8.71	50.78	---	74.00	54.00	-3.22	Peak
5415.00	40.44	---	10.26	50.70	---	74.00	54.00	-3.30	Peak
6108.00	38.05	---	12.72	50.77	---	74.00	54.00	-3.23	Peak
7344.00	37.64	---	13.16	50.80	---	74.00	54.00	-3.20	Peak
9060.00	37.25	---	15.25	52.49	---	74.00	54.00	-1.51	Peak

966 Chamber_B at 3Meter / Vertical									
Frequency (MHz)	Reading-PK (dBuV)	Reading-AV (dBuV)	Correction Factor (dB/m)	Result-PK (dBuV/m)	Result-AV (dBuV/m)	Limit-PK (dBuV/m)	Limit-AV (dBuV/m)	Margin (dB)	Remark
4660.00	42.01	---	8.77	50.78	---	74.00	54.00	-3.22	Peak
5440.00	40.55	---	10.36	50.91	---	74.00	54.00	-3.09	Peak
5975.00	39.50	---	12.66	52.16	---	74.00	54.00	-1.84	Peak
6132.00	38.24	---	12.71	50.95	---	74.00	54.00	-3.05	Peak
7608.00	37.53	---	13.06	50.59	---	74.00	54.00	-3.41	Peak
9048.00	36.70	---	15.23	51.92	---	74.00	54.00	-2.08	Peak

Remark:

1. Measuring frequencies from 1 GHz to the 10th harmonic of highest fundamental frequency.
2. Average test would be performed if the peak result were greater than the average limit.
3. Data of measurement within this frequency range shown " --- " in the table above means the reading of emissions are attenuated more than 20dB below the permissible limits or the field strength is too small to be measured.
4. Measurements above show only up to 6 maximum emissions noted, or would be lesser, with " N/A " remark, if no specific emissions from the EUT are recorded (ie: margin>20dB from the applicable limit) and considered that's already beyond the background noise floor.
5. Result = Reading + Correction Factor
Margin = Result - Limit
Remark Peak = Result(PK) - Limit(AV)
Remark AVG = Result(AV) - Limit(AV)



Product Name	Panel PC	Test By	Rex Chiu
Test Model	VM-521	Test Date	2014/11/19
Test Mode	UNII Band 2C / IEEE 802.11ac VHT40 TX / CH Low / Internal Antenna	Temp. & Humidity	21°C, 56%

966 Chamber_B at 3Meter / Horizontal									
Frequency (MHz)	Reading-PK (dBuV)	Reading-AV (dBuV)	Correction Factor (dB/m)	Result-PK (dBuV/m)	Result-AV (dBuV/m)	Limit-PK (dBuV/m)	Limit-AV (dBuV/m)	Margin (dB)	Remark
1645.00	51.36	---	-0.66	50.69	---	74.00	54.00	-3.31	Peak
4695.00	41.95	---	8.76	50.70	---	74.00	54.00	-3.30	Peak
5995.00	39.57	---	12.75	52.32	---	74.00	54.00	-1.68	Peak
6252.00	38.13	---	12.66	50.79	---	74.00	54.00	-3.21	Peak
7776.00	38.00	---	13.55	51.55	---	74.00	54.00	-2.45	Peak
8940.00	36.75	---	15.20	51.94	---	74.00	54.00	-2.06	Peak

966 Chamber_B at 3Meter / Vertical									
Frequency (MHz)	Reading-PK (dBuV)	Reading-AV (dBuV)	Correction Factor (dB/m)	Result-PK (dBuV/m)	Result-AV (dBuV/m)	Limit-PK (dBuV/m)	Limit-AV (dBuV/m)	Margin (dB)	Remark
3265.00	44.72	---	5.24	49.95	---	74.00	54.00	-4.05	Peak
3880.00	42.86	---	6.18	49.04	---	74.00	54.00	-4.96	Peak
4655.00	41.67	---	8.78	50.45	---	74.00	54.00	-3.55	Peak
6168.00	38.01	---	12.70	50.71	---	74.00	54.00	-3.29	Peak
7764.00	37.94	---	13.52	51.46	---	74.00	54.00	-2.54	Peak
9108.00	36.75	---	15.32	52.08	---	74.00	54.00	-1.92	Peak

Remark:

1. Measuring frequencies from 1 GHz to the 10th harmonic of highest fundamental frequency.
2. Average test would be performed if the peak result were greater than the average limit.
3. Data of measurement within this frequency range shown " --- " in the table above means the reading of emissions are attenuated more than 20dB below the permissible limits or the field strength is too small to be measured.
4. Measurements above show only up to 6 maximum emissions noted, or would be lesser, with " N/A " remark, if no specific emissions from the EUT are recorded (ie: margin>20dB from the applicable limit) and considered that's already beyond the background noise floor.
5. Result = Reading + Correction Factor
Margin = Result - Limit
Remark Peak = Result(PK) - Limit(AV)
Remark AVG = Result(AV) - Limit(AV)



Product Name	Panel PC	Test By	Rex Chiu
Test Model	VM-521	Test Date	2014/11/19
Test Mode	UNII Band 2C / IEEE 802.11ac VHT40 TX / CH Middle / Internal Antenna	Temp. & Humidity	21°C, 56%

966 Chamber_B at 3Meter / Horizontal									
Frequency (MHz)	Reading-PK (dBuV)	Reading-AV (dBuV)	Correction Factor (dB/m)	Result-PK (dBuV/m)	Result-AV (dBuV/m)	Limit-PK (dBuV/m)	Limit-AV (dBuV/m)	Margin (dB)	Remark
3970.00	43.21	---	6.31	49.51	---	74.00	54.00	-4.49	Peak
4665.00	41.83	---	8.77	50.60	---	74.00	54.00	-3.40	Peak
5460.00	46.55	32.35	10.44	57.00	42.79	74.00	54.00	-11.21	Peak
6216.00	39.18	---	12.67	51.85	---	74.00	54.00	-2.15	Peak
7608.00	38.06	---	13.06	51.12	---	74.00	54.00	-2.88	Peak
8952.00	36.75	---	15.19	51.94	---	74.00	54.00	-2.06	Peak

966 Chamber_B at 3Meter / Vertical									
Frequency (MHz)	Reading-PK (dBuV)	Reading-AV (dBuV)	Correction Factor (dB/m)	Result-PK (dBuV/m)	Result-AV (dBuV/m)	Limit-PK (dBuV/m)	Limit-AV (dBuV/m)	Margin (dB)	Remark
3050.00	43.41	---	4.87	48.29	---	74.00	54.00	-5.71	Peak
4555.00	41.87	---	8.82	50.69	---	74.00	54.00	-3.31	Peak
5460.00	41.83	---	10.44	52.27	---	74.00	54.00	-1.73	Peak
6048.00	37.68	---	12.75	50.43	---	74.00	54.00	-3.57	Peak
7452.00	38.74	---	12.88	51.62	---	74.00	54.00	-2.38	Peak
8352.00	36.78	---	15.14	51.91	---	74.00	54.00	-2.09	Peak

Remark:

1. Measuring frequencies from 1 GHz to the 10th harmonic of highest fundamental frequency.
2. Average test would be performed if the peak result were greater than the average limit.
3. Data of measurement within this frequency range shown " --- " in the table above means the reading of emissions are attenuated more than 20dB below the permissible limits or the field strength is too small to be measured.
4. Measurements above show only up to 6 maximum emissions noted, or would be lesser, with " N/A " remark, if no specific emissions from the EUT are recorded (ie: margin>20dB from the applicable limit) and considered that's already beyond the background noise floor.
5. Result = Reading + Correction Factor
Margin = Result - Limit
Remark Peak = Result(PK) - Limit(AV)
Remark AVG = Result(AV) - Limit(AV)



Product Name	Panel PC	Test By	Rex Chiu
Test Model	VM-521	Test Date	2014/11/19
Test Mode	UNII Band 2C / IEEE 802.11ac VHT40 TX / CH High / Internal Antenna	Temp. & Humidity	21°C, 56%

966 Chamber_B at 3Meter / Horizontal									
Frequency (MHz)	Reading-PK (dBuV)	Reading-AV (dBuV)	Correction Factor (dB/m)	Result-PK (dBuV/m)	Result-AV (dBuV/m)	Limit-PK (dBuV/m)	Limit-AV (dBuV/m)	Margin (dB)	Remark
3240.00	43.48	---	5.19	48.67	---	74.00	54.00	-5.33	Peak
4645.00	41.97	---	8.78	50.75	---	74.00	54.00	-3.25	Peak
5400.00	41.47	---	10.20	51.68	---	74.00	54.00	-2.32	Peak
6108.00	37.61	---	12.72	50.33	---	74.00	54.00	-3.67	Peak
7464.00	39.19	---	12.85	52.03	---	74.00	54.00	-1.97	Peak
9072.00	36.02	---	15.27	51.29	---	74.00	54.00	-2.71	Peak

966 Chamber_B at 3Meter / Vertical									
Frequency (MHz)	Reading-PK (dBuV)	Reading-AV (dBuV)	Correction Factor (dB/m)	Result-PK (dBuV/m)	Result-AV (dBuV/m)	Limit-PK (dBuV/m)	Limit-AV (dBuV/m)	Margin (dB)	Remark
3200.00	43.13	---	5.13	48.26	---	74.00	54.00	-5.74	Peak
4640.00	42.58	---	8.78	51.36	---	74.00	54.00	-2.64	Peak
5395.00	41.38	---	10.18	51.56	---	74.00	54.00	-2.44	Peak
6204.00	38.67	---	12.68	51.35	---	74.00	54.00	-2.65	Peak
7812.00	37.74	---	13.65	51.39	---	74.00	54.00	-2.61	Peak
9084.00	36.78	---	15.29	52.07	---	74.00	54.00	-1.93	Peak

Remark:

1. Measuring frequencies from 1 GHz to the 10th harmonic of highest fundamental frequency.
2. Average test would be performed if the peak result were greater than the average limit.
3. Data of measurement within this frequency range shown " --- " in the table above means the reading of emissions are attenuated more than 20dB below the permissible limits or the field strength is too small to be measured.
4. Measurements above show only up to 6 maximum emissions noted, or would be lesser, with " N/A " remark, if no specific emissions from the EUT are recorded (ie: margin>20dB from the applicable limit) and considered that's already beyond the background noise floor.
5. Result = Reading + Correction Factor
Margin = Result - Limit
Remark Peak = Result(PK) - Limit(AV)
Remark AVG = Result(AV) - Limit(AV)



Product Name	Panel PC	Test By	Rex Chiu
Test Model	VM-521	Test Date	2014/11/19
Test Mode	UNII Band 2C / IEEE 802.11ac VHT80 TX / CH Low / Internal Antenna	Temp. & Humidity	21°C, 56%

966 Chamber_B at 3Meter / Horizontal									
Frequency (MHz)	Reading-PK (dBuV)	Reading-AV (dBuV)	Correction Factor (dB/m)	Result-PK (dBuV/m)	Result-AV (dBuV/m)	Limit-PK (dBuV/m)	Limit-AV (dBuV/m)	Margin (dB)	Remark
1630.00	46.72	---	-0.80	45.92	---	74.00	54.00	-8.08	Peak
3175.00	44.44	---	5.08	49.53	---	74.00	54.00	-4.47	Peak
4535.00	42.68	---	8.83	51.51	---	74.00	54.00	-2.49	Peak
6036.00	39.14	---	12.75	51.89	---	74.00	54.00	-2.11	Peak
7500.00	37.96	---	12.75	50.71	---	74.00	54.00	-3.29	Peak
9120.00	37.07	---	15.34	52.42	---	74.00	54.00	-1.58	Peak

966 Chamber_B at 3Meter / Vertical									
Frequency (MHz)	Reading-PK (dBuV)	Reading-AV (dBuV)	Correction Factor (dB/m)	Result-PK (dBuV/m)	Result-AV (dBuV/m)	Limit-PK (dBuV/m)	Limit-AV (dBuV/m)	Margin (dB)	Remark
3230.00	43.96	---	5.18	49.14	---	74.00	54.00	-4.86	Peak
3980.00	43.67	---	6.32	49.99	---	74.00	54.00	-4.01	Peak
4665.00	42.64	---	8.77	51.41	---	74.00	54.00	-2.59	Peak
6036.00	37.66	---	12.75	50.42	---	74.00	54.00	-3.58	Peak
7572.00	37.94	---	12.96	50.90	---	74.00	54.00	-3.10	Peak
9108.00	36.83	---	15.32	52.15	---	74.00	54.00	-1.85	Peak

Remark:

1. Measuring frequencies from 1 GHz to the 10th harmonic of highest fundamental frequency.
2. Average test would be performed if the peak result were greater than the average limit.
3. Data of measurement within this frequency range shown " --- " in the table above means the reading of emissions are attenuated more than 20dB below the permissible limits or the field strength is too small to be measured.
4. Measurements above show only up to 6 maximum emissions noted, or would be lesser, with " N/A " remark, if no specific emissions from the EUT are recorded (ie: margin>20dB from the applicable limit) and considered that's already beyond the background noise floor.
5. Result = Reading + Correction Factor
Margin = Result - Limit
Remark Peak = Result(PK) - Limit(AV)
Remark AVG = Result(AV) - Limit(AV)



Product Name	Panel PC	Test By	Rex Chiu
Test Model	VM-521	Test Date	2014/11/19
Test Mode	UNII Band 3 / IEEE 802.11a TX / CH Low / Internal Antenna	Temp. & Humidity	21°C, 56%

966 Chamber_B at 3Meter / Horizontal

Frequency (MHz)	Reading-PK (dBuV)	Reading-AV (dBuV)	Correction Factor (dB/m)	Result-PK (dBuV/m)	Result-AV (dBuV/m)	Limit-PK (dBuV/m)	Limit-AV (dBuV/m)	Margin (dB)	Remark
3905.00	43.33	---	6.21	49.55	---	74.00	54.00	-4.45	Peak
4785.00	42.19	---	8.71	50.90	---	74.00	54.00	-3.10	Peak
5380.00	40.96	---	10.12	51.08	---	74.00	54.00	-2.92	Peak
6072.00	38.35	---	12.74	51.09	---	74.00	54.00	-2.91	Peak
7392.00	38.22	---	13.04	51.25	---	74.00	54.00	-2.75	Peak
8136.00	37.18	---	14.56	51.74	---	74.00	54.00	-2.26	Peak

966 Chamber_B at 3Meter / Vertical

Frequency (MHz)	Reading-PK (dBuV)	Reading-AV (dBuV)	Correction Factor (dB/m)	Result-PK (dBuV/m)	Result-AV (dBuV/m)	Limit-PK (dBuV/m)	Limit-AV (dBuV/m)	Margin (dB)	Remark
3215.00	44.34	---	5.15	49.49	---	74.00	54.00	-4.51	Peak
4680.00	41.54	---	8.76	50.30	---	74.00	54.00	-3.70	Peak
5440.00	41.05	---	10.36	51.42	---	74.00	54.00	-2.58	Peak
6120.00	38.26	---	12.72	50.98	---	74.00	54.00	-3.02	Peak
7380.00	38.48	---	13.07	51.54	---	74.00	54.00	-2.46	Peak
8952.00	36.39	---	15.19	51.58	---	74.00	54.00	-2.42	Peak

Remark:

1. Measuring frequencies from 1 GHz to the 10th harmonic of highest fundamental frequency.
2. Average test would be performed if the peak result were greater than the average limit.
3. Data of measurement within this frequency range shown " --- " in the table above means the reading of emissions are attenuated more than 20dB below the permissible limits or the field strength is too small to be measured.
4. Measurements above show only up to 6 maximum emissions noted, or would be lesser, with " N/A " remark, if no specific emissions from the EUT are recorded (ie: margin>20dB from the applicable limit) and considered that's already beyond the background noise floor.
5. Result = Reading + Correction Factor
Margin = Result - Limit
Remark Peak = Result(PK) - Limit(AV)
Remark AVG = Result(AV) - Limit(AV)



Product Name	Panel PC	Test By	Rex Chiu
Test Model	VM-521	Test Date	2014/11/19
Test Mode	UNII Band 3 / IEEE 802.11a TX / CH Middle / Internal Antenna	Temp. & Humidity	21°C, 56%

966 Chamber_B at 3Meter / Horizontal									
Frequency (MHz)	Reading-PK (dBuV)	Reading-AV (dBuV)	Correction Factor (dB/m)	Result-PK (dBuV/m)	Result-AV (dBuV/m)	Limit-PK (dBuV/m)	Limit-AV (dBuV/m)	Margin (dB)	Remark
3255.00	42.77	---	5.22	47.99	---	74.00	54.00	-6.01	Peak
4675.00	41.66	---	8.77	50.43	---	74.00	54.00	-3.57	Peak
5410.00	40.93	---	10.24	51.17	---	74.00	54.00	-2.83	Peak
6156.00	38.18	---	12.70	50.88	---	74.00	54.00	-3.12	Peak
7296.00	38.54	---	13.29	51.83	---	74.00	54.00	-2.17	Peak
8244.00	36.78	---	14.85	51.63	---	74.00	54.00	-2.37	Peak

966 Chamber_B at 3Meter / Vertical									
Frequency (MHz)	Reading-PK (dBuV)	Reading-AV (dBuV)	Correction Factor (dB/m)	Result-PK (dBuV/m)	Result-AV (dBuV/m)	Limit-PK (dBuV/m)	Limit-AV (dBuV/m)	Margin (dB)	Remark
3630.00	43.18	---	5.82	49.00	---	74.00	54.00	-5.00	Peak
4640.00	42.60	---	8.78	51.38	---	74.00	54.00	-2.62	Peak
5395.00	40.85	---	10.18	51.04	---	74.00	54.00	-2.96	Peak
6204.00	38.29	---	12.68	50.97	---	74.00	54.00	-3.03	Peak
7464.00	38.05	---	12.85	50.89	---	74.00	54.00	-3.11	Peak
8880.00	37.26	---	15.24	52.50	---	74.00	54.00	-1.50	Peak

Remark:

1. Measuring frequencies from 1 GHz to the 10th harmonic of highest fundamental frequency.
2. Average test would be performed if the peak result were greater than the average limit.
3. Data of measurement within this frequency range shown " --- " in the table above means the reading of emissions are attenuated more than 20dB below the permissible limits or the field strength is too small to be measured.
4. Measurements above show only up to 6 maximum emissions noted, or would be lesser, with " N/A " remark, if no specific emissions from the EUT are recorded (ie: margin>20dB from the applicable limit) and considered that's already beyond the background noise floor.
5. Result = Reading + Correction Factor
Margin = Result - Limit
Remark Peak = Result(PK) - Limit(AV)
Remark AVG = Result(AV) - Limit(AV)



Product Name	Panel PC	Test By	Rex Chiu
Test Model	VM-521	Test Date	2014/11/19
Test Mode	UNII Band 3 / IEEE 802.11a TX / CH High / Internal Antenna	Temp. & Humidity	21°C, 56%

966 Chamber_B at 3Meter / Horizontal									
Frequency (MHz)	Reading-PK (dBuV)	Reading-AV (dBuV)	Correction Factor (dB/m)	Result-PK (dBuV/m)	Result-AV (dBuV/m)	Limit-PK (dBuV/m)	Limit-AV (dBuV/m)	Margin (dB)	Remark
3305.00	43.23	---	5.30	48.53	---	74.00	54.00	-5.47	Peak
4615.00	42.04	---	8.79	50.83	---	74.00	54.00	-3.17	Peak
5455.00	41.02	---	10.42	51.44	---	74.00	54.00	-2.56	Peak
6120.00	38.28	---	12.72	50.99	---	74.00	54.00	-3.01	Peak
7716.00	37.44	---	13.38	50.81	---	74.00	54.00	-3.19	Peak
8832.00	37.07	---	15.28	52.35	---	74.00	54.00	-1.65	Peak

966 Chamber_B at 3Meter / Vertical									
Frequency (MHz)	Reading-PK (dBuV)	Reading-AV (dBuV)	Correction Factor (dB/m)	Result-PK (dBuV/m)	Result-AV (dBuV/m)	Limit-PK (dBuV/m)	Limit-AV (dBuV/m)	Margin (dB)	Remark
3365.00	43.39	---	5.40	48.79	---	74.00	54.00	-5.21	Peak
4510.00	42.41	---	8.85	51.25	---	74.00	54.00	-2.75	Peak
5440.00	40.74	---	10.36	51.10	---	74.00	54.00	-2.90	Peak
6132.00	37.89	---	12.71	50.60	---	74.00	54.00	-3.40	Peak
7200.00	38.03	---	13.54	51.57	---	74.00	54.00	-2.43	Peak
8496.00	36.49	---	15.52	52.01	---	74.00	54.00	-1.99	Peak

Remark:

1. Measuring frequencies from 1 GHz to the 10th harmonic of highest fundamental frequency.
2. Average test would be performed if the peak result were greater than the average limit.
3. Data of measurement within this frequency range shown " --- " in the table above means the reading of emissions are attenuated more than 20dB below the permissible limits or the field strength is too small to be measured.
4. Measurements above show only up to 6 maximum emissions noted, or would be lesser, with " N/A " remark, if no specific emissions from the EUT are recorded (ie: margin>20dB from the applicable limit) and considered that's already beyond the background noise floor.
5. Result = Reading + Correction Factor
Margin = Result - Limit
Remark Peak = Result(PK) - Limit(AV)
Remark AVG = Result(AV) - Limit(AV)



Product Name	Panel PC	Test By	Rex Chiu
Test Model	VM-521	Test Date	2014/11/19
Test Mode	UNII Band 3 / IEEE 802.11ac VHT20 TX / CH Low / Internal Antenna	Temp. & Humidity	21°C, 56%

966 Chamber_B at 3Meter / Horizontal									
Frequency (MHz)	Reading-PK (dBuV)	Reading-AV (dBuV)	Correction Factor (dB/m)	Result-PK (dBuV/m)	Result-AV (dBuV/m)	Limit-PK (dBuV/m)	Limit-AV (dBuV/m)	Margin (dB)	Remark
3175.00	43.35	---	5.08	48.43	---	74.00	54.00	-5.57	Peak
4685.00	42.47	---	8.76	51.23	---	74.00	54.00	-2.77	Peak
5405.00	40.54	---	10.22	50.76	---	74.00	54.00	-3.24	Peak
6192.00	37.87	---	12.69	50.56	---	74.00	54.00	-3.44	Peak
7560.00	37.92	---	12.92	50.85	---	74.00	54.00	-3.15	Peak
8988.00	36.64	---	15.16	51.80	---	74.00	54.00	-2.20	Peak

966 Chamber_B at 3Meter / Vertical									
Frequency (MHz)	Reading-PK (dBuV)	Reading-AV (dBuV)	Correction Factor (dB/m)	Result-PK (dBuV/m)	Result-AV (dBuV/m)	Limit-PK (dBuV/m)	Limit-AV (dBuV/m)	Margin (dB)	Remark
3080.00	43.27	---	4.92	48.20	---	74.00	54.00	-5.80	Peak
4610.00	41.53	---	8.80	50.32	---	74.00	54.00	-3.68	Peak
5370.00	40.73	---	10.08	50.82	---	74.00	54.00	-3.18	Peak
6180.00	37.77	---	12.69	50.46	---	74.00	54.00	-3.54	Peak
7248.00	37.88	---	13.42	51.30	---	74.00	54.00	-2.70	Peak
8376.00	36.55	---	15.20	51.75	---	74.00	54.00	-2.25	Peak

Remark:

1. Measuring frequencies from 1 GHz to the 10th harmonic of highest fundamental frequency.
2. Average test would be performed if the peak result were greater than the average limit.
3. Data of measurement within this frequency range shown " --- " in the table above means the reading of emissions are attenuated more than 20dB below the permissible limits or the field strength is too small to be measured.
4. Measurements above show only up to 6 maximum emissions noted, or would be lesser, with " N/A " remark, if no specific emissions from the EUT are recorded (ie: margin>20dB from the applicable limit) and considered that's already beyond the background noise floor.
5. Result = Reading + Correction Factor
Margin = Result - Limit
Remark Peak = Result(PK) - Limit(AV)
Remark AVG = Result(AV) - Limit(AV)



Product Name	Panel PC	Test By	Rex Chiu
Test Model	VM-521	Test Date	2014/11/19
Test Mode	UNII Band 3 / IEEE 802.11ac VHT20 TX / CH Middle / Internal Antenna	Temp. & Humidity	21°C, 56%

966 Chamber_B at 3Meter / Horizontal

Frequency (MHz)	Reading-PK (dBuV)	Reading-AV (dBuV)	Correction Factor (dB/m)	Result-PK (dBuV/m)	Result-AV (dBuV/m)	Limit-PK (dBuV/m)	Limit-AV (dBuV/m)	Margin (dB)	Remark
3115.00	44.27	---	4.98	49.25	---	74.00	54.00	-4.75	Peak
4780.00	42.26	---	8.72	50.98	---	74.00	54.00	-3.02	Peak
5435.00	40.64	---	10.34	50.98	---	74.00	54.00	-3.02	Peak
6204.00	37.70	---	12.68	50.38	---	74.00	54.00	-3.62	Peak
7716.00	37.52	---	13.38	50.89	---	74.00	54.00	-3.11	Peak
9036.00	36.08	---	15.21	51.29	---	74.00	54.00	-2.71	Peak

966 Chamber_B at 3Meter / Vertical

Frequency (MHz)	Reading-PK (dBuV)	Reading-AV (dBuV)	Correction Factor (dB/m)	Result-PK (dBuV/m)	Result-AV (dBuV/m)	Limit-PK (dBuV/m)	Limit-AV (dBuV/m)	Margin (dB)	Remark
3075.00	43.61	---	4.92	48.52	---	74.00	54.00	-5.48	Peak
4545.00	42.30	---	8.83	51.12	---	74.00	54.00	-2.88	Peak
5400.00	41.44	---	10.20	51.65	---	74.00	54.00	-2.35	Peak
6060.00	38.31	---	12.74	51.05	---	74.00	54.00	-2.95	Peak
7404.00	38.45	---	13.00	51.45	---	74.00	54.00	-2.55	Peak
8928.00	36.50	---	15.20	51.71	---	74.00	54.00	-2.29	Peak

Remark:

1. Measuring frequencies from 1 GHz to the 10th harmonic of highest fundamental frequency.
2. Average test would be performed if the peak result were greater than the average limit.
3. Data of measurement within this frequency range shown " --- " in the table above means the reading of emissions are attenuated more than 20dB below the permissible limits or the field strength is too small to be measured.
4. Measurements above show only up to 6 maximum emissions noted, or would be lesser, with " N/A " remark, if no specific emissions from the EUT are recorded (ie: margin>20dB from the applicable limit) and considered that's already beyond the background noise floor.
5. Result = Reading + Correction Factor
Margin = Result - Limit
Remark Peak = Result(PK) - Limit(AV)
Remark AVG = Result(AV) - Limit(AV)



Product Name	Panel PC	Test By	Rex Chiu
Test Model	VM-521	Test Date	2014/11/19
Test Mode	UNII Band 3 / IEEE 802.11ac VHT20 TX / CH High / Internal Antenna	Temp. & Humidity	21°C, 56%

966 Chamber_B at 3Meter / Horizontal									
Frequency (MHz)	Reading-PK (dBuV)	Reading-AV (dBuV)	Correction Factor (dB/m)	Result-PK (dBuV/m)	Result-AV (dBuV/m)	Limit-PK (dBuV/m)	Limit-AV (dBuV/m)	Margin (dB)	Remark
1600.00	48.27	---	-1.08	47.19	---	74.00	54.00	-6.81	Peak
4755.00	42.03	---	8.73	50.76	---	74.00	54.00	-3.24	Peak
5380.00	41.01	---	10.12	51.13	---	74.00	54.00	-2.87	Peak
6144.00	39.17	---	12.71	51.87	---	74.00	54.00	-2.13	Peak
6984.00	38.10	---	14.02	52.12	---	74.00	54.00	-1.88	Peak
8316.00	36.55	---	15.04	51.59	---	74.00	54.00	-2.41	Peak

966 Chamber_B at 3Meter / Vertical									
Frequency (MHz)	Reading-PK (dBuV)	Reading-AV (dBuV)	Correction Factor (dB/m)	Result-PK (dBuV/m)	Result-AV (dBuV/m)	Limit-PK (dBuV/m)	Limit-AV (dBuV/m)	Margin (dB)	Remark
3170.00	43.79	---	5.08	48.87	---	74.00	54.00	-5.13	Peak
4560.00	41.92	---	8.82	50.74	---	74.00	54.00	-3.26	Peak
5450.00	39.97	---	10.40	50.37	---	74.00	54.00	-3.63	Peak
6288.00	38.52	---	12.64	51.17	---	74.00	54.00	-2.83	Peak
7716.00	37.80	---	13.38	51.18	---	74.00	54.00	-2.82	Peak
8964.00	36.66	---	15.18	51.84	---	74.00	54.00	-2.16	Peak

Remark:

1. Measuring frequencies from 1 GHz to the 10th harmonic of highest fundamental frequency.
2. Average test would be performed if the peak result were greater than the average limit.
3. Data of measurement within this frequency range shown " --- " in the table above means the reading of emissions are attenuated more than 20dB below the permissible limits or the field strength is too small to be measured.
4. Measurements above show only up to 6 maximum emissions noted, or would be lesser, with " N/A " remark, if no specific emissions from the EUT are recorded (ie: margin>20dB from the applicable limit) and considered that's already beyond the background noise floor.
5. Result = Reading + Correction Factor
Margin = Result - Limit
Remark Peak = Result(PK) - Limit(AV)
Remark AVG = Result(AV) - Limit(AV)



Product Name	Panel PC	Test By	Rex Chiu
Test Model	TREK-674	Test Date	2014/11/19
Test Mode	UNII Band 3 / IEEE 802.11ac VHT40 TX / CH Low / Internal Antenna	Temp. & Humidity	21°C, 56%

966 Chamber_B at 3Meter / Horizontal									
Frequency (MHz)	Reading-PK (dBuV)	Reading-AV (dBuV)	Correction Factor (dB/m)	Result-PK (dBuV/m)	Result-AV (dBuV/m)	Limit-PK (dBuV/m)	Limit-AV (dBuV/m)	Margin (dB)	Remark
3165.00	44.05	---	5.07	49.11	---	74.00	54.00	-4.89	Peak
4665.00	41.69	---	8.77	50.46	---	74.00	54.00	-3.54	Peak
5360.00	41.69	---	10.04	51.73	---	74.00	54.00	-2.27	Peak
6120.00	37.85	---	12.72	50.57	---	74.00	54.00	-3.43	Peak
7860.00	37.92	---	13.79	51.71	---	74.00	54.00	-2.29	Peak
9084.00	37.08	---	15.29	52.37	---	74.00	54.00	-1.63	Peak

966 Chamber_B at 3Meter / Vertical									
Frequency (MHz)	Reading-PK (dBuV)	Reading-AV (dBuV)	Correction Factor (dB/m)	Result-PK (dBuV/m)	Result-AV (dBuV/m)	Limit-PK (dBuV/m)	Limit-AV (dBuV/m)	Margin (dB)	Remark
3285.00	43.64	---	5.27	48.91	---	74.00	54.00	-5.09	Peak
4800.00	42.45	---	8.71	51.15	---	74.00	54.00	-2.85	Peak
5435.00	40.50	---	10.34	50.84	---	74.00	54.00	-3.16	Peak
6288.00	38.90	---	12.64	51.54	---	74.00	54.00	-2.46	Peak
7176.00	37.78	---	13.61	51.39	---	74.00	54.00	-2.61	Peak
8856.00	37.18	---	15.26	52.44	---	74.00	54.00	-1.56	Peak

Remark:

1. Measuring frequencies from 1 GHz to the 10th harmonic of highest fundamental frequency.
2. Average test would be performed if the peak result were greater than the average limit.
3. Data of measurement within this frequency range shown " --- " in the table above means the reading of emissions are attenuated more than 20dB below the permissible limits or the field strength is too small to be measured.
4. Measurements above show only up to 6 maximum emissions noted, or would be lesser, with " N/A " remark, if no specific emissions from the EUT are recorded (ie: margin>20dB from the applicable limit) and considered that's already beyond the background noise floor.
5. Result = Reading + Correction Factor
Margin = Result - Limit
Remark Peak = Result(PK) - Limit(AV)
Remark AVG = Result(AV) - Limit(AV)



Product Name	Panel PC	Test By	Rex Chiu
Test Model	VM-521	Test Date	2014/11/19
Test Mode	UNII Band 3 / IEEE 802.11ac VHT40 TX / CH High / Internal Antenna	Temp. & Humidity	21°C, 56%

966 Chamber_B at 3Meter / Horizontal									
Frequency (MHz)	Reading-PK (dBuV)	Reading-AV (dBuV)	Correction Factor (dB/m)	Result-PK (dBuV/m)	Result-AV (dBuV/m)	Limit-PK (dBuV/m)	Limit-AV (dBuV/m)	Margin (dB)	Remark
3090.00	44.38	---	4.94	49.32	---	74.00	54.00	-4.68	Peak
4720.00	42.15	---	8.74	50.89	---	74.00	54.00	-3.11	Peak
5375.00	40.60	---	10.10	50.70	---	74.00	54.00	-3.30	Peak
6120.00	38.61	---	12.72	51.32	---	74.00	54.00	-2.68	Peak
7164.00	38.41	---	13.64	52.05	---	74.00	54.00	-1.95	Peak
8928.00	36.72	---	15.20	51.93	---	74.00	54.00	-2.07	Peak

966 Chamber_B at 3Meter / Vertical									
Frequency (MHz)	Reading-PK (dBuV)	Reading-AV (dBuV)	Correction Factor (dB/m)	Result-PK (dBuV/m)	Result-AV (dBuV/m)	Limit-PK (dBuV/m)	Limit-AV (dBuV/m)	Margin (dB)	Remark
3105.00	44.13	---	4.97	49.10	---	74.00	54.00	-4.90	Peak
4540.00	42.16	---	8.83	51.00	---	74.00	54.00	-3.00	Peak
5445.00	40.55	---	10.38	50.93	---	74.00	54.00	-3.07	Peak
6096.00	38.43	---	12.73	51.16	---	74.00	54.00	-2.84	Peak
7296.00	38.22	---	13.29	51.51	---	74.00	54.00	-2.49	Peak
8268.00	36.29	---	14.91	51.20	---	74.00	54.00	-2.80	Peak

Remark:

1. Measuring frequencies from 1 GHz to the 10th harmonic of highest fundamental frequency.
2. Average test would be performed if the peak result were greater than the average limit.
3. Data of measurement within this frequency range shown " --- " in the table above means the reading of emissions are attenuated more than 20dB below the permissible limits or the field strength is too small to be measured.
4. Measurements above show only up to 6 maximum emissions noted, or would be lesser, with " N/A " remark, if no specific emissions from the EUT are recorded (ie: margin>20dB from the applicable limit) and considered that's already beyond the background noise floor.
5. Result = Reading + Correction Factor
Margin = Result - Limit
Remark Peak = Result(PK) - Limit(AV)
Remark AVG = Result(AV) - Limit(AV)



Product Name	Panel PC	Test By	Rex Chiu
Test Model	VM-521	Test Date	2014/11/19
Test Mode	UNII Band 3 / IEEE 802.11ac VHT80 TX / CH Low / Internal Antenna	Temp. & Humidity	21°C, 56%

966 Chamber_B at 3Meter / Horizontal

Frequency (MHz)	Reading-PK (dBuV)	Reading-AV (dBuV)	Correction Factor (dB/m)	Result-PK (dBuV/m)	Result-AV (dBuV/m)	Limit-PK (dBuV/m)	Limit-AV (dBuV/m)	Margin (dB)	Remark
3235.00	43.65	---	5.18	48.84	---	74.00	54.00	-5.16	Peak
4660.00	42.20	---	8.77	50.98	---	74.00	54.00	-3.02	Peak
5360.00	41.47	---	10.04	51.52	---	74.00	54.00	-2.48	Peak
6096.00	37.94	---	12.73	50.66	---	74.00	54.00	-3.34	Peak
7404.00	38.22	---	13.00	51.22	---	74.00	54.00	-2.78	Peak
8868.00	36.63	---	15.25	51.88	---	74.00	54.00	-2.12	Peak

966 Chamber_B at 3Meter / Vertical

Frequency (MHz)	Reading-PK (dBuV)	Reading-AV (dBuV)	Correction Factor (dB/m)	Result-PK (dBuV/m)	Result-AV (dBuV/m)	Limit-PK (dBuV/m)	Limit-AV (dBuV/m)	Margin (dB)	Remark
3200.00	43.62	---	5.13	48.75	---	74.00	54.00	-5.25	Peak
4650.00	41.52	---	8.78	50.30	---	74.00	54.00	-3.70	Peak
5390.00	40.57	---	10.16	50.73	---	74.00	54.00	-3.27	Peak
6024.00	37.60	---	12.76	50.36	---	74.00	54.00	-3.64	Peak
7512.00	37.95	---	12.78	50.74	---	74.00	54.00	-3.26	Peak
9084.00	36.97	---	15.29	52.26	---	74.00	54.00	-1.74	Peak

Remark:

1. Measuring frequencies from 1 GHz to the 10th harmonic of highest fundamental frequency.
2. Average test would be performed if the peak result were greater than the average limit.
3. Data of measurement within this frequency range shown " --- " in the table above means the reading of emissions are attenuated more than 20dB below the permissible limits or the field strength is too small to be measured.
4. Measurements above show only up to 6 maximum emissions noted, or would be lesser, with " N/A " remark, if no specific emissions from the EUT are recorded (ie: margin>20dB from the applicable limit) and considered that's already beyond the background noise floor.
5. Result = Reading + Correction Factor
Margin = Result - Limit
Remark Peak = Result(PK) - Limit(AV)
Remark AVG = Result(AV) - Limit(AV)



Restricted Band Edges

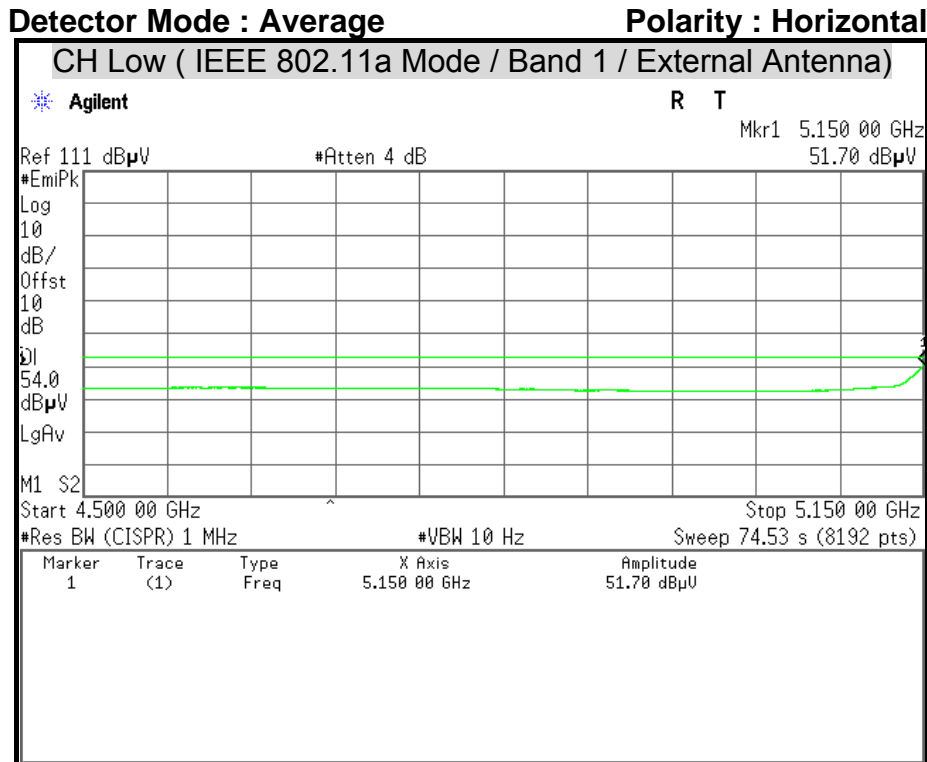
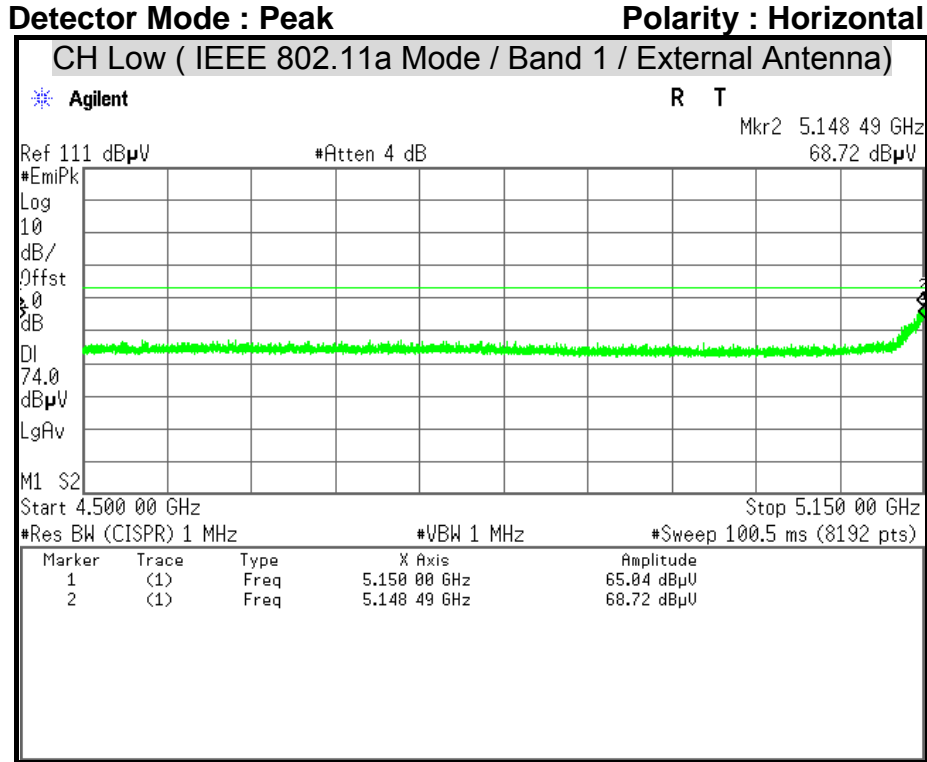



Detector Mode : Peak

Polarity : Vertical

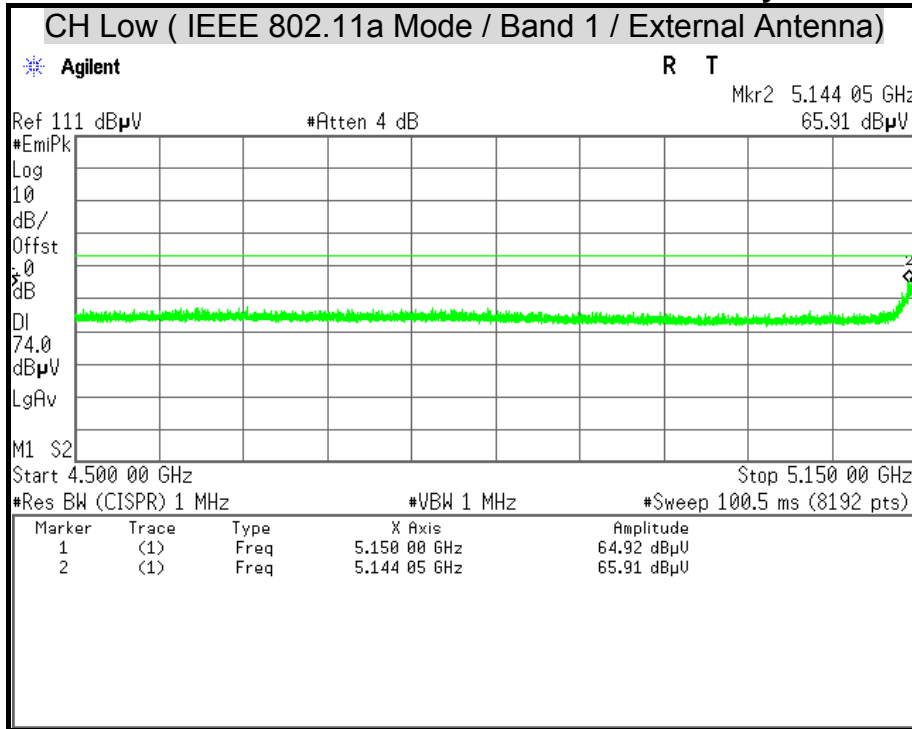

Detector Mode : Average

Polarity : Vertical

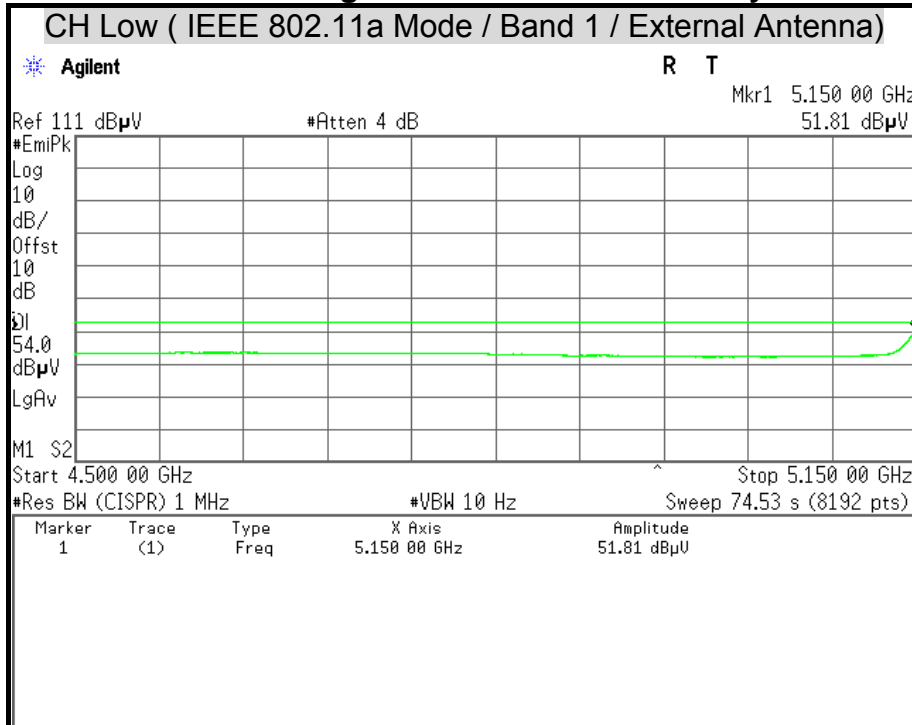



Detector Mode : Peak

Polarity : Horizontal

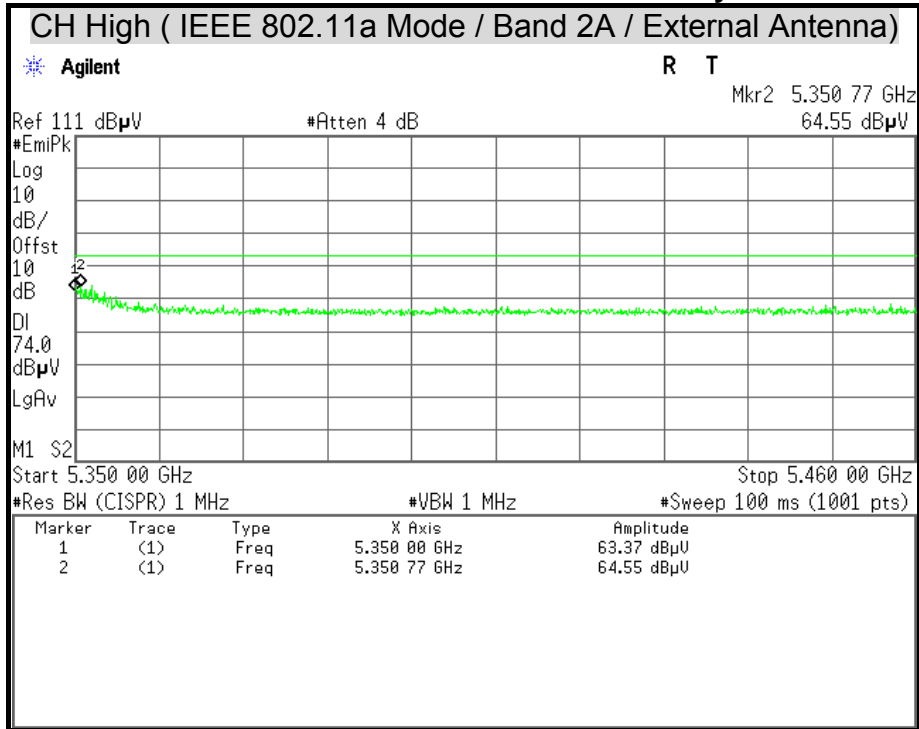

Detector Mode : Average

Polarity : Horizontal

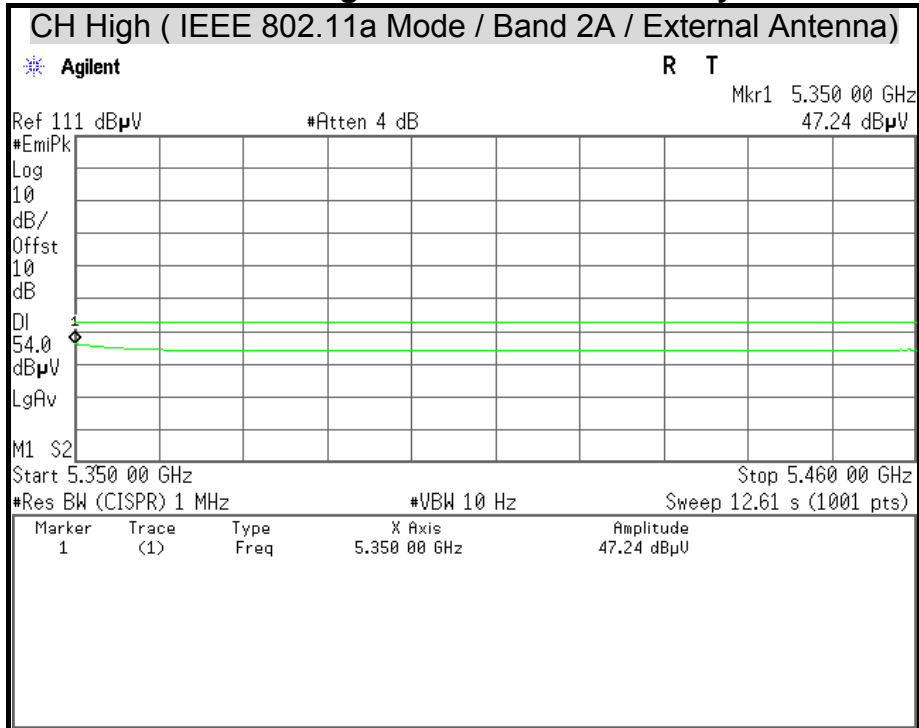



Detector Mode : Peak

Polarity : Vertical

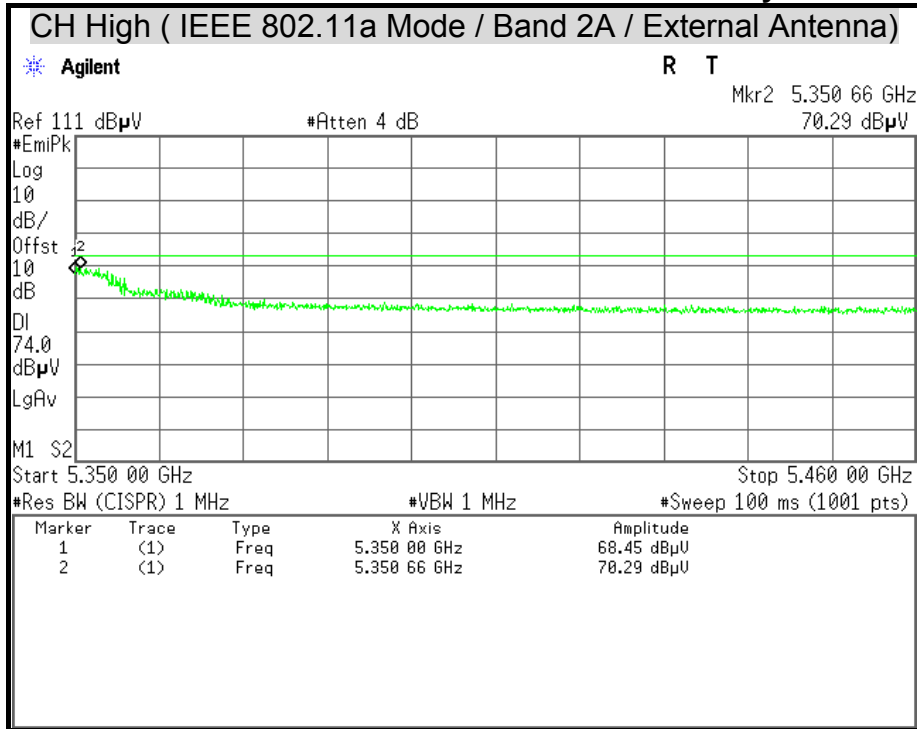

Detector Mode : Average

Polarity : Vertical

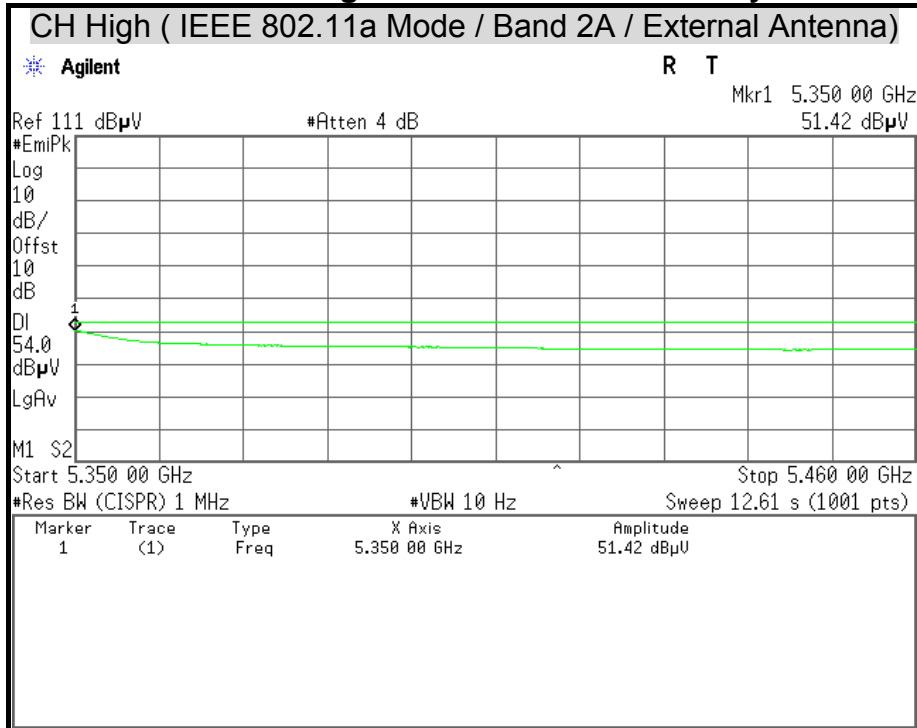



Detector Mode : Peak

Polarity : Horizontal

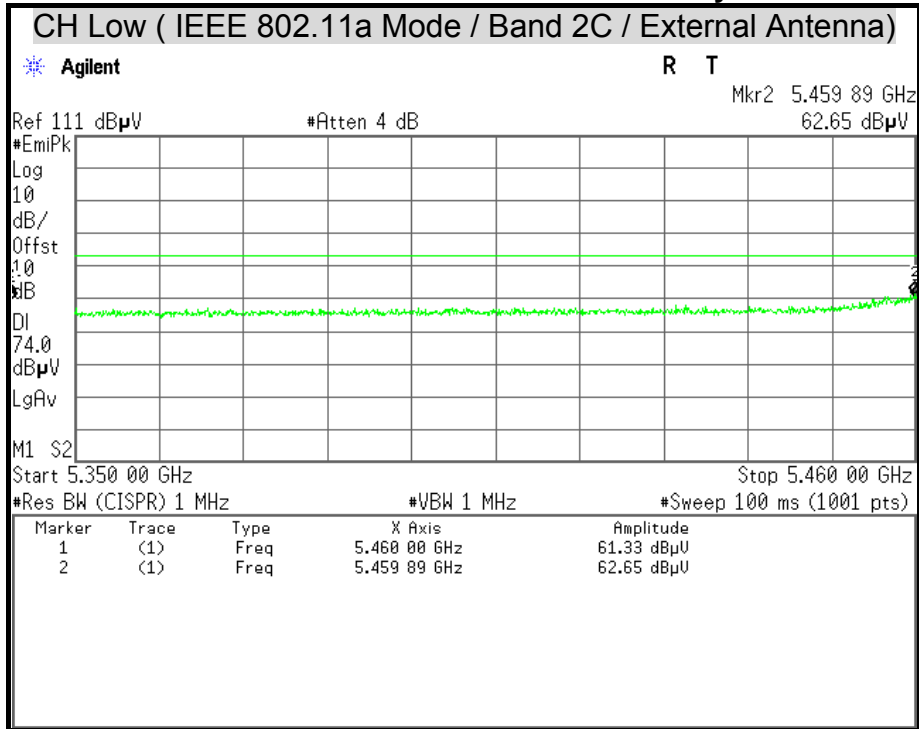

Detector Mode : Average

Polarity : Horizontal

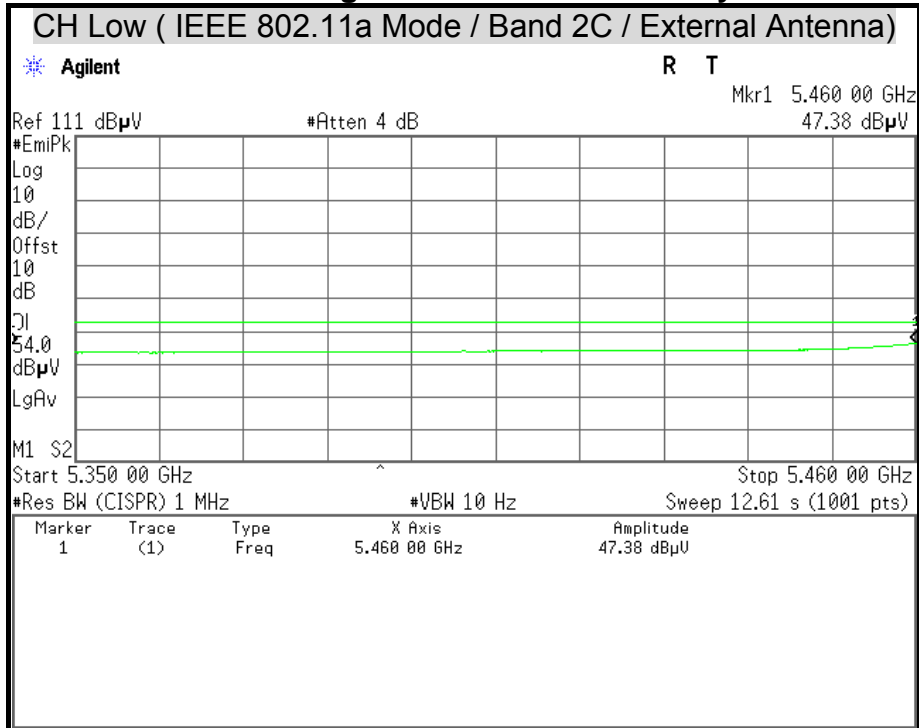



Detector Mode : Peak

Polarity : Vertical

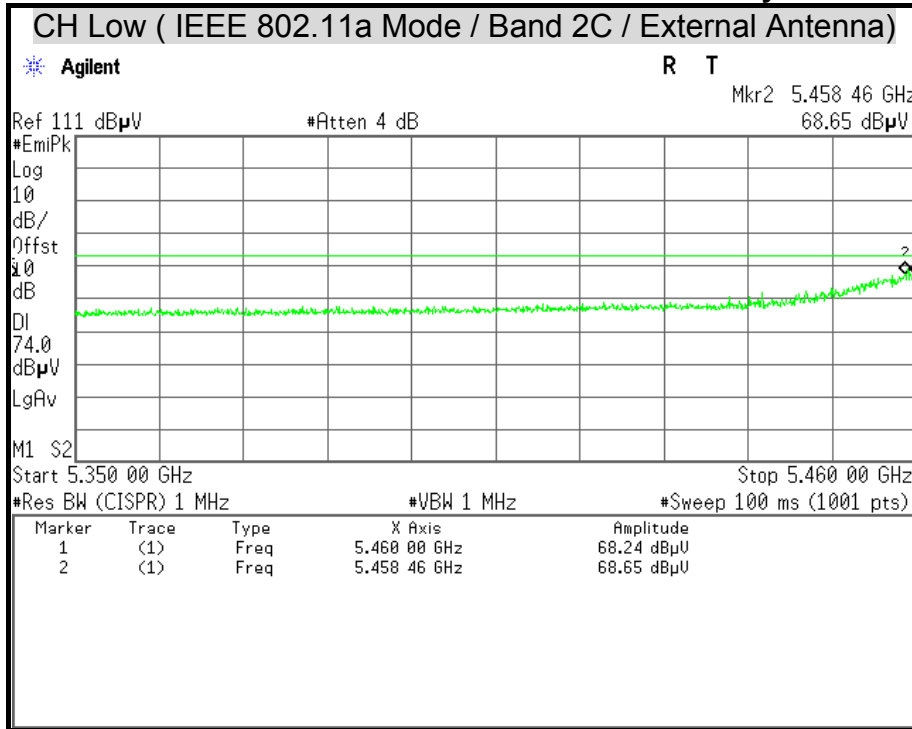

Detector Mode : Average

Polarity : Vertical

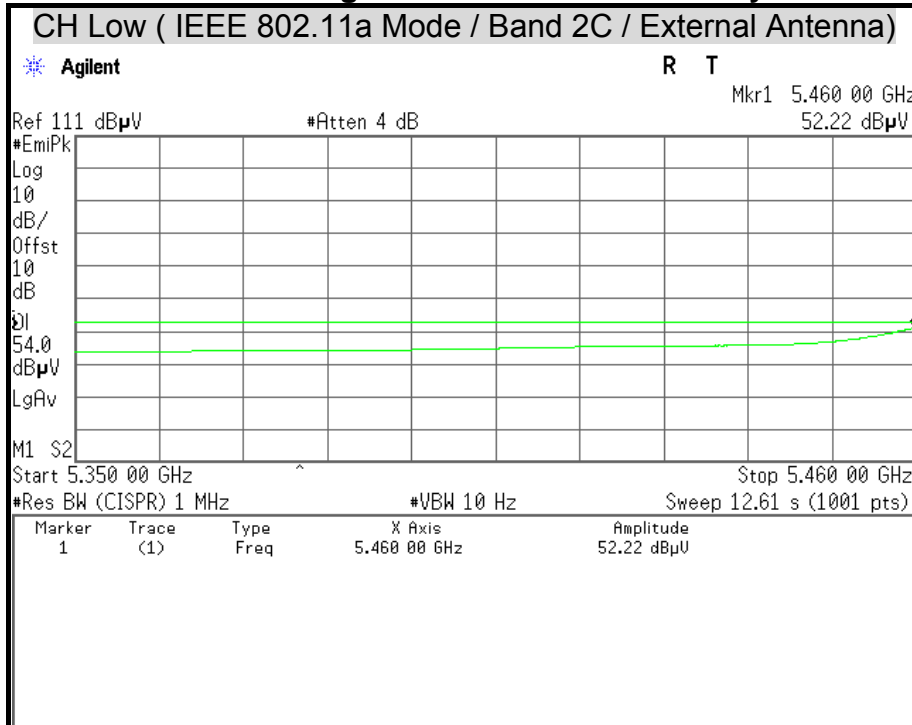



Detector Mode : Peak

Polarity : Horizontal

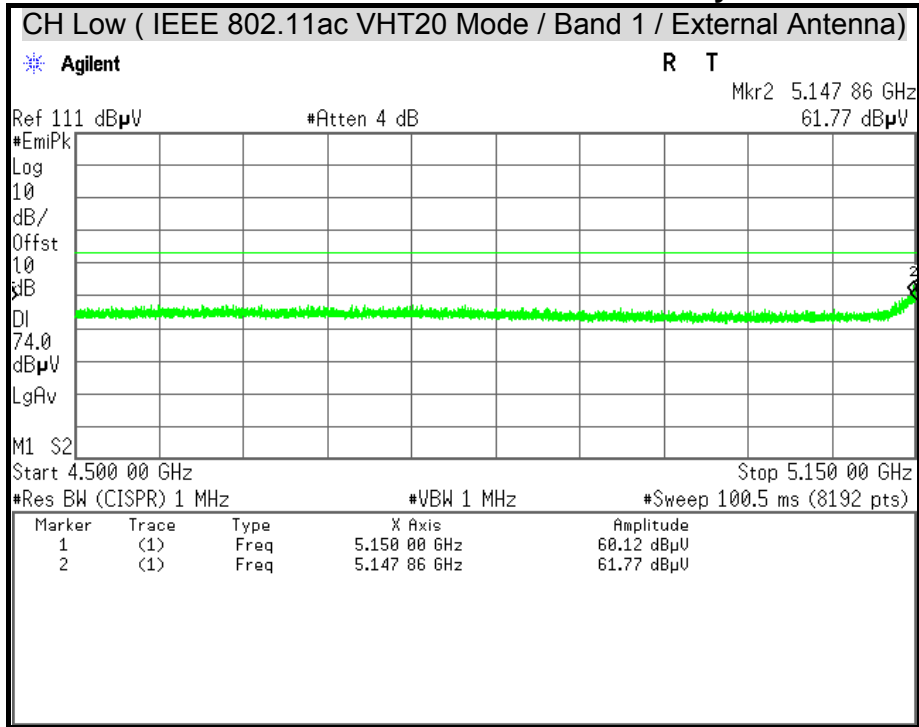

Detector Mode : Average

Polarity : Horizontal

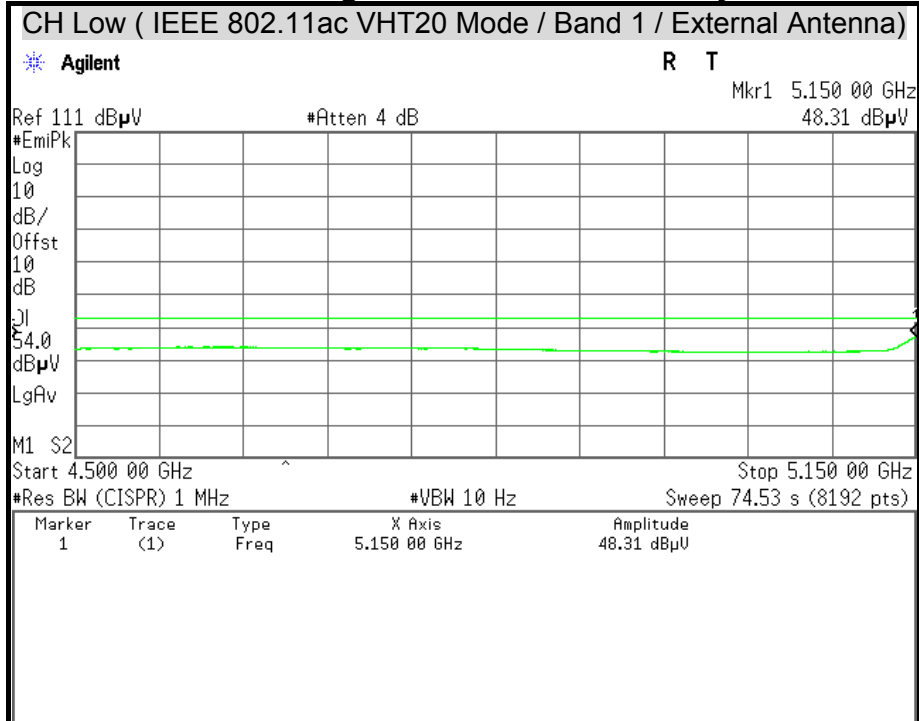



Detector Mode : Peak

Polarity : Vertical

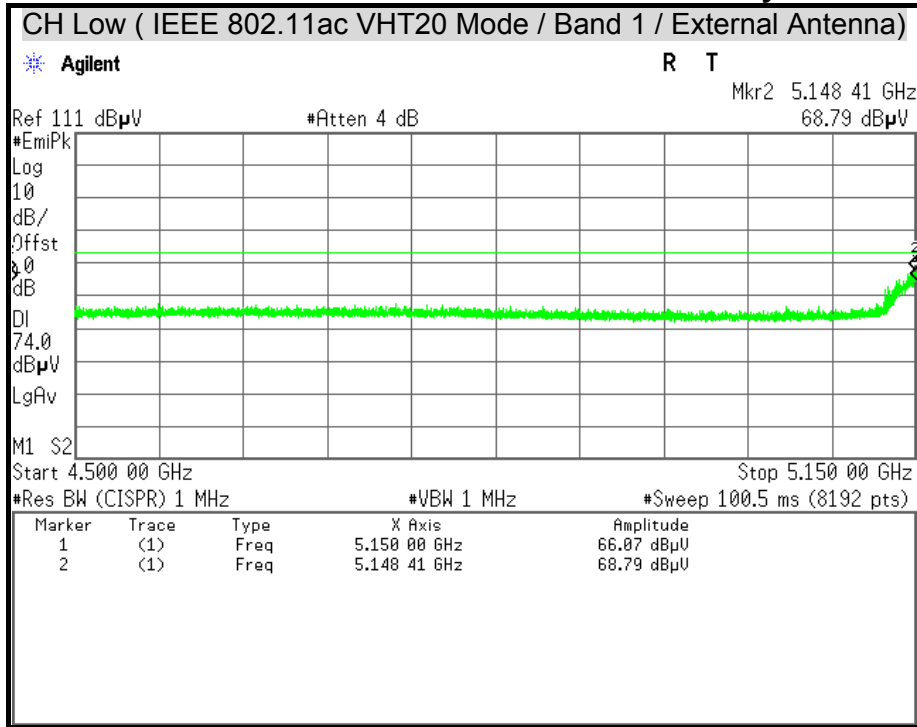

Detector Mode : Average

Polarity : Vertical

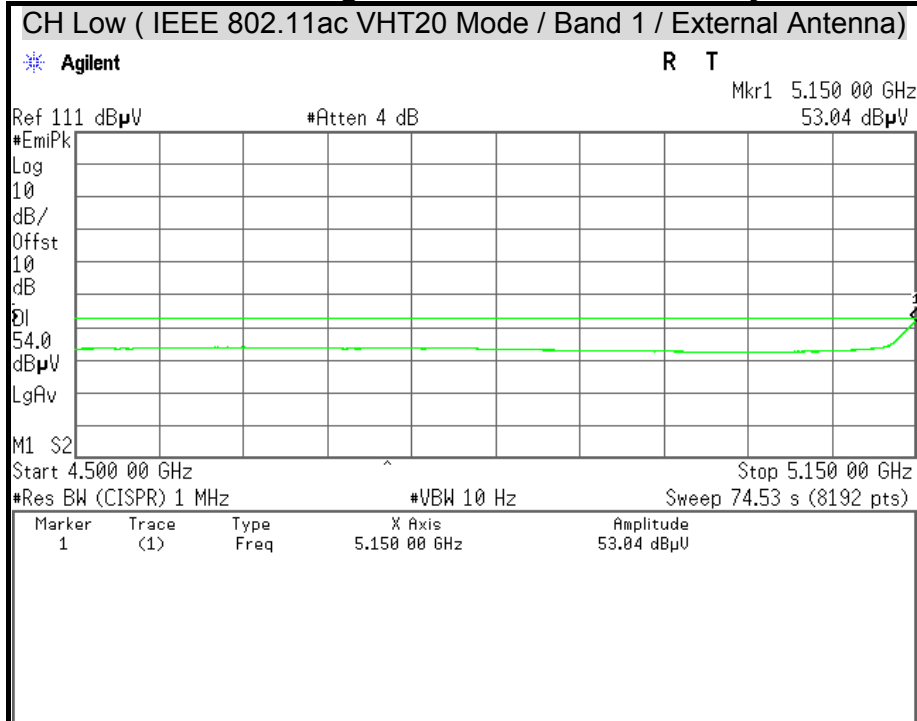



Detector Mode : Peak

Polarity : Horizontal

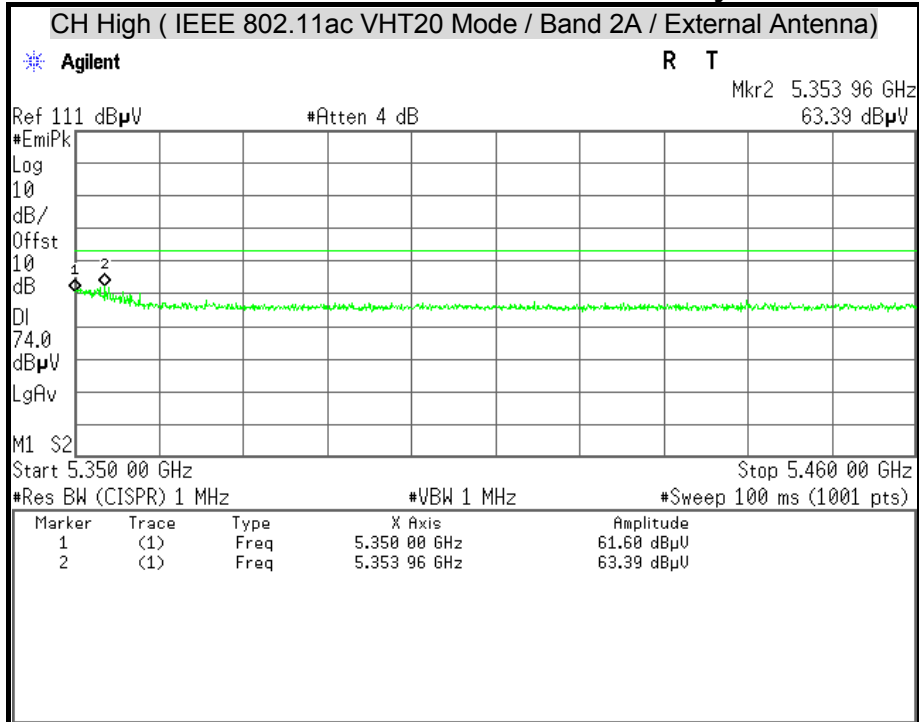

Detector Mode : Average

Polarity : Horizontal

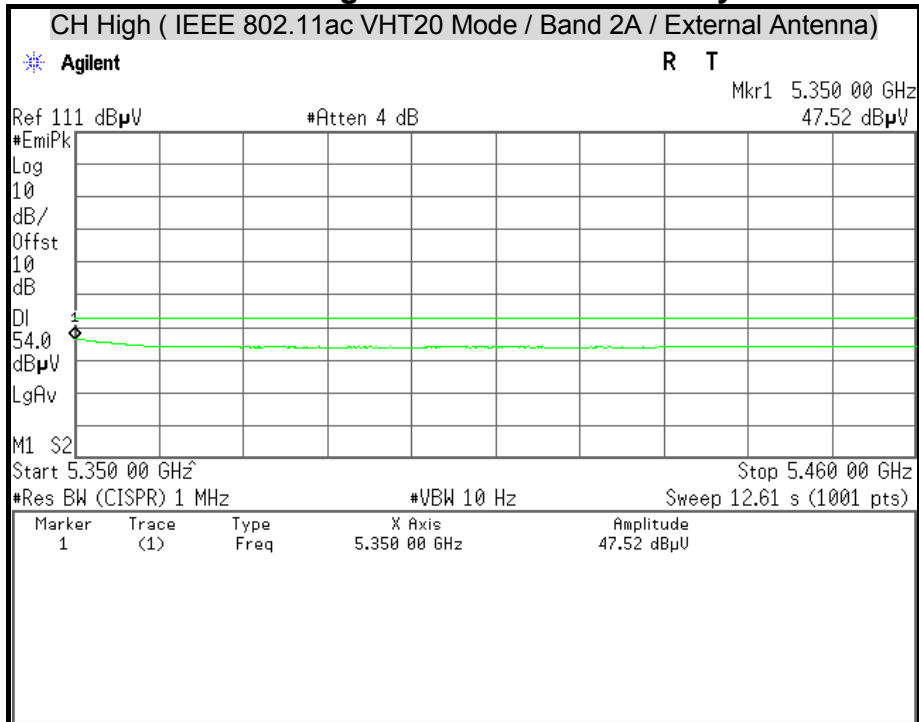



Detector Mode : Peak

Polarity : Vertical

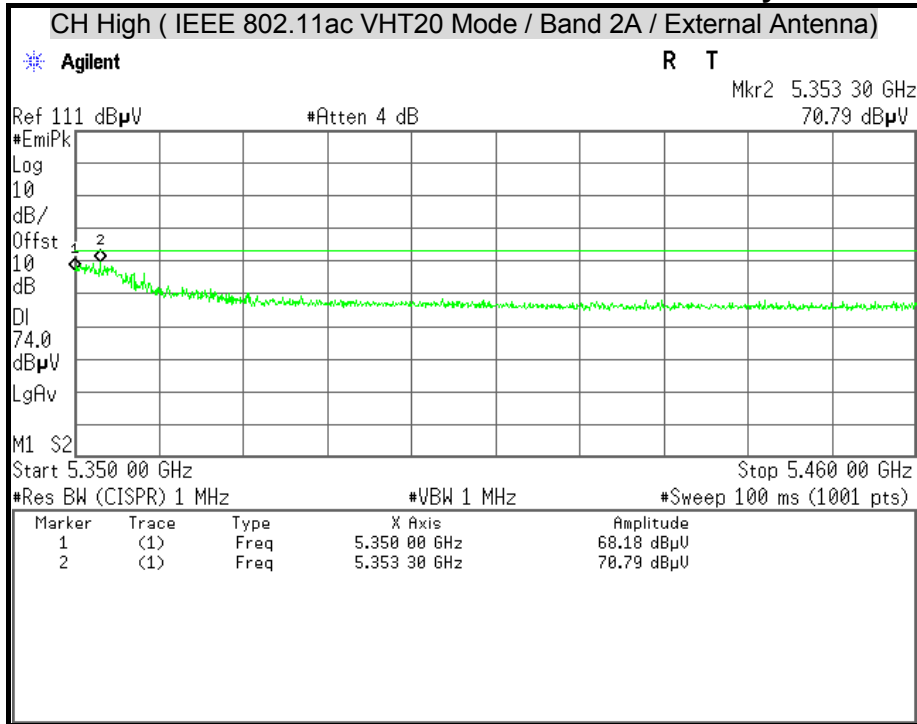

Detector Mode : Average

Polarity : Vertical

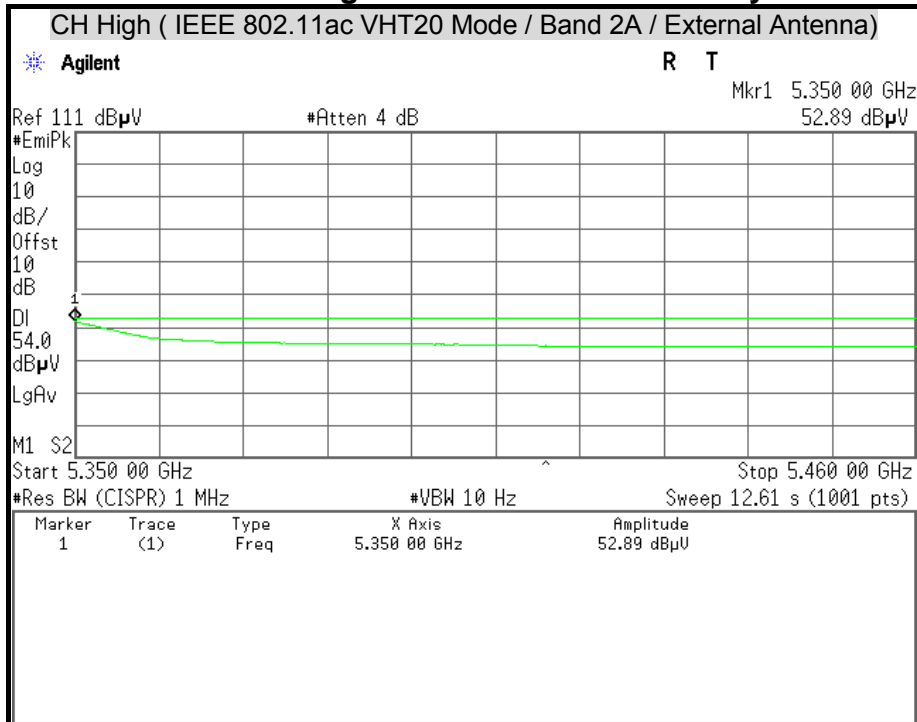



Detector Mode : Peak

Polarity : Horizontal

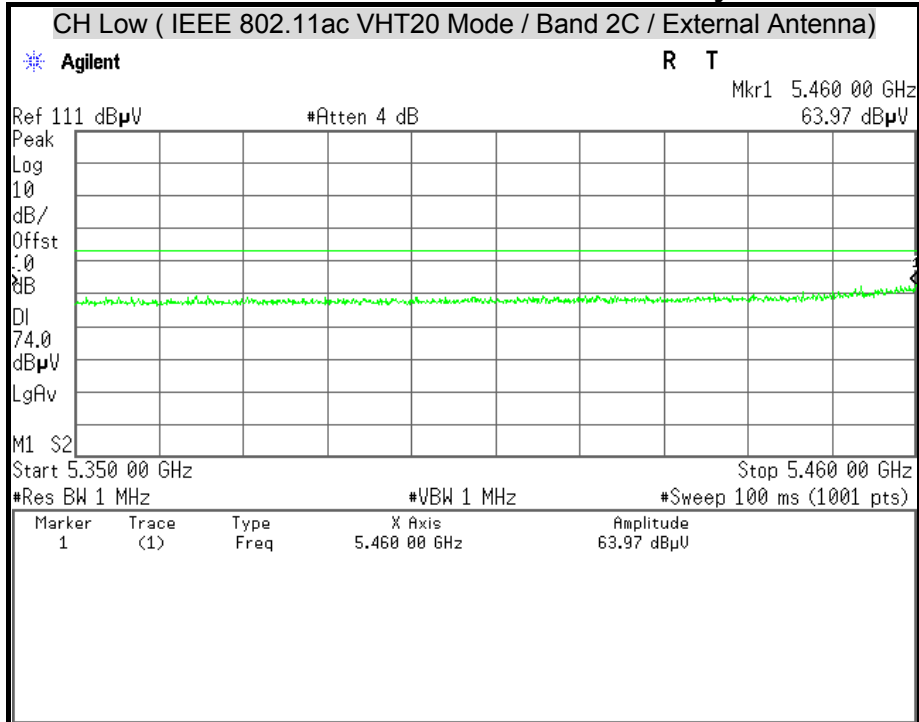

Detector Mode : Average

Polarity : Horizontal

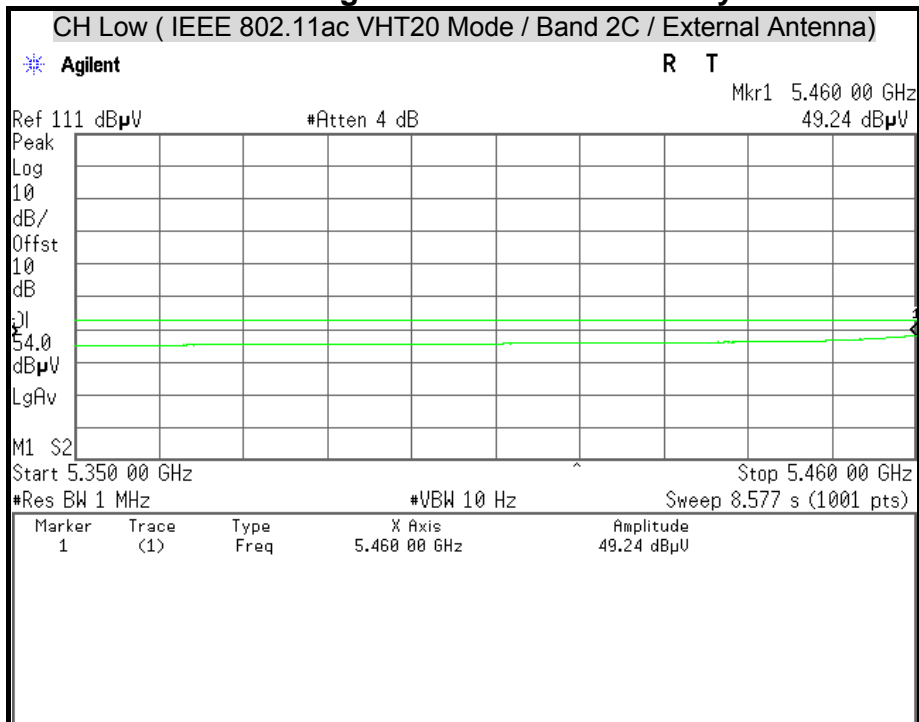



Detector Mode : Peak

Polarity : Vertical

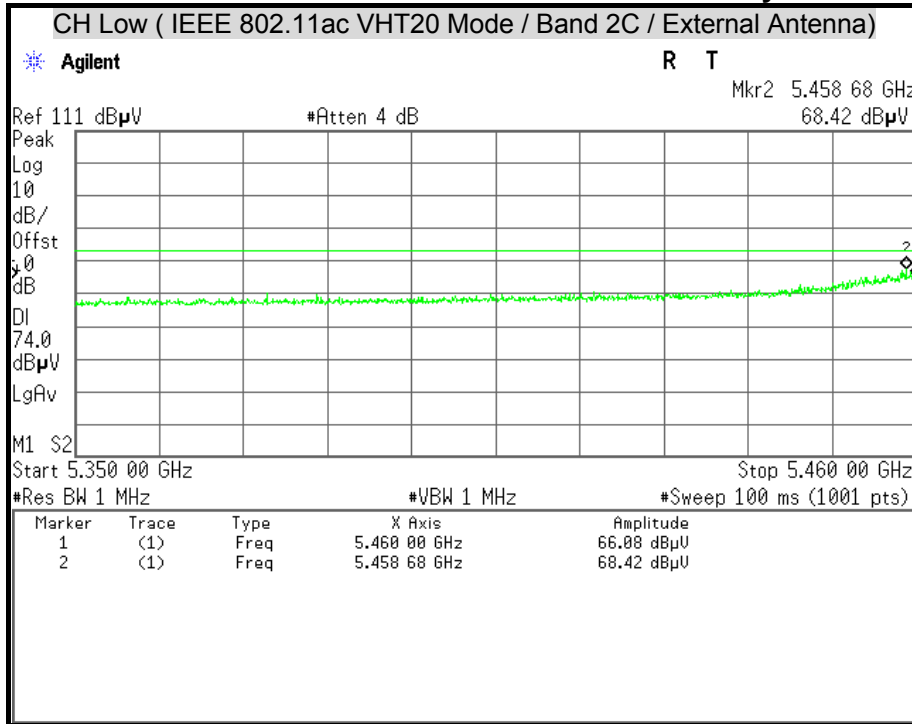

Detector Mode : Average

Polarity : Vertical

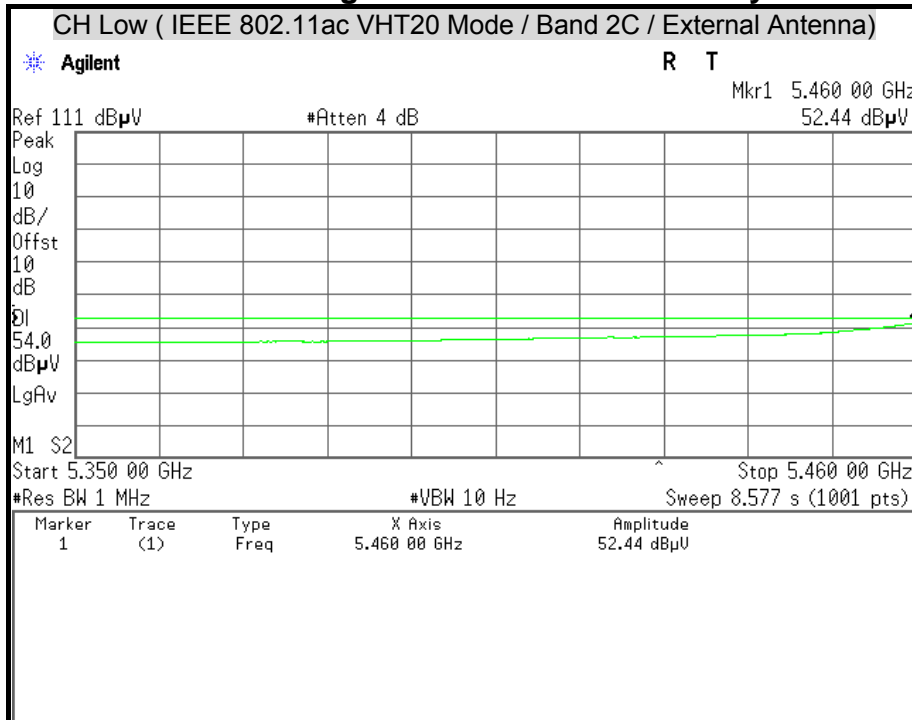



Detector Mode : Peak

Polarity : Horizontal

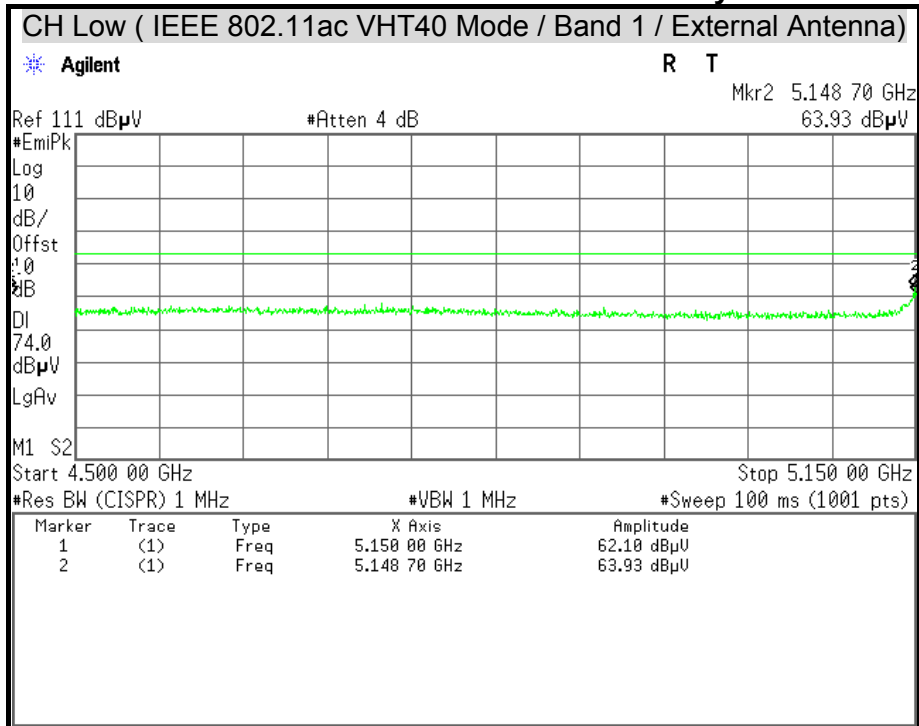

Detector Mode : Average

Polarity : Horizontal

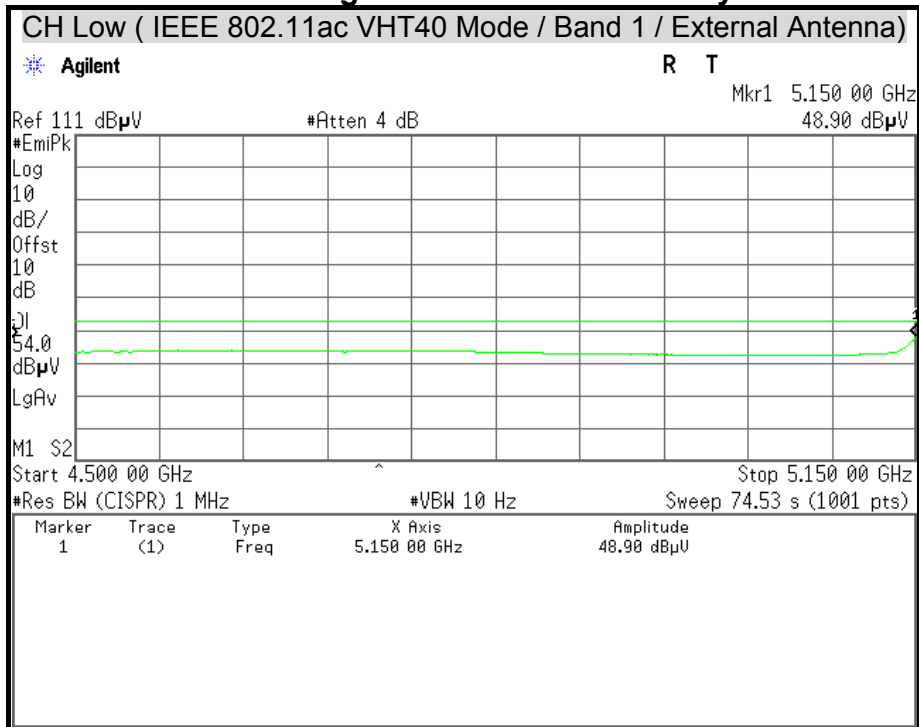



Detector Mode : Peak

Polarity : Vertical

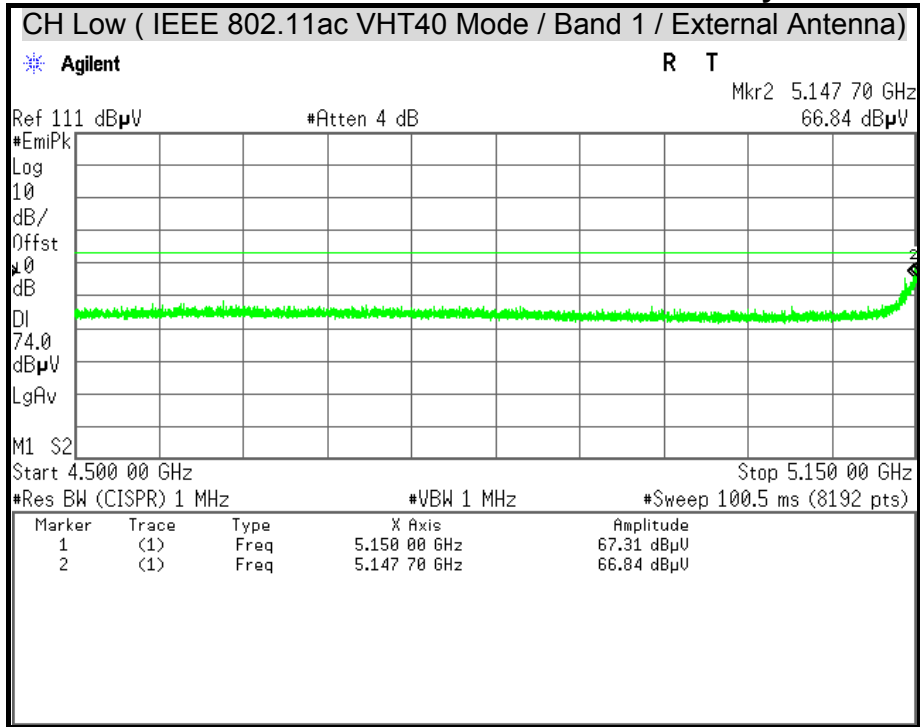

Detector Mode : Average

Polarity : Vertical

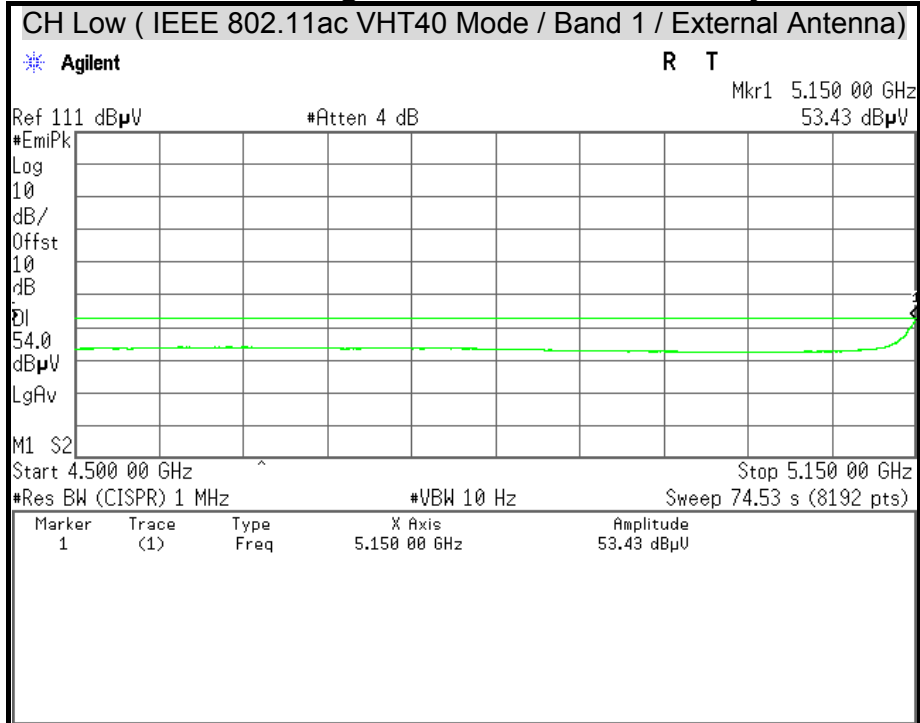



Detector Mode : Peak

Polarity : Horizontal

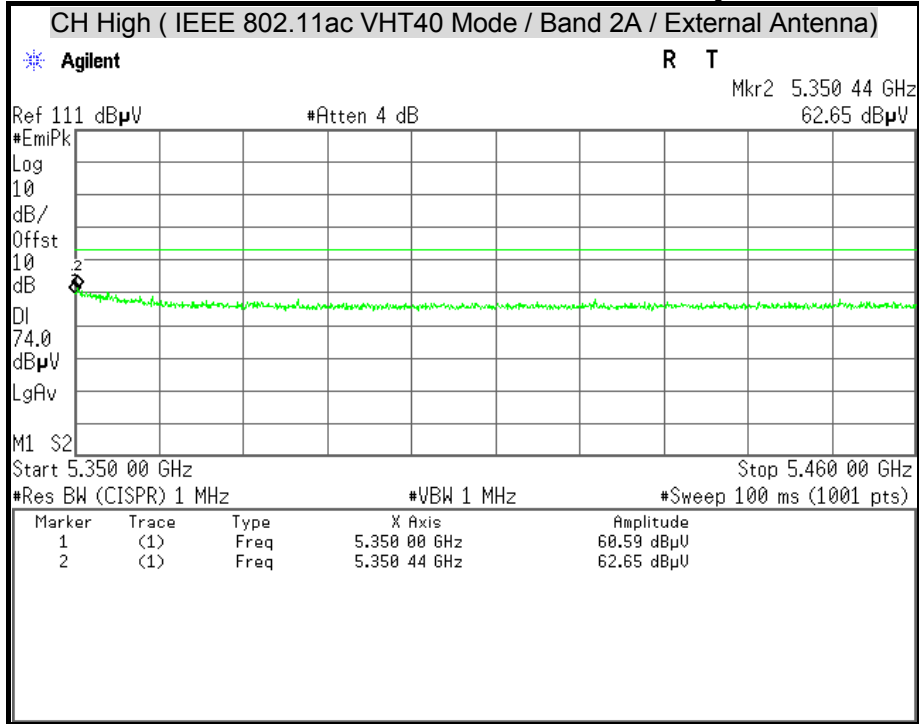

Detector Mode : Average

Polarity : Horizontal

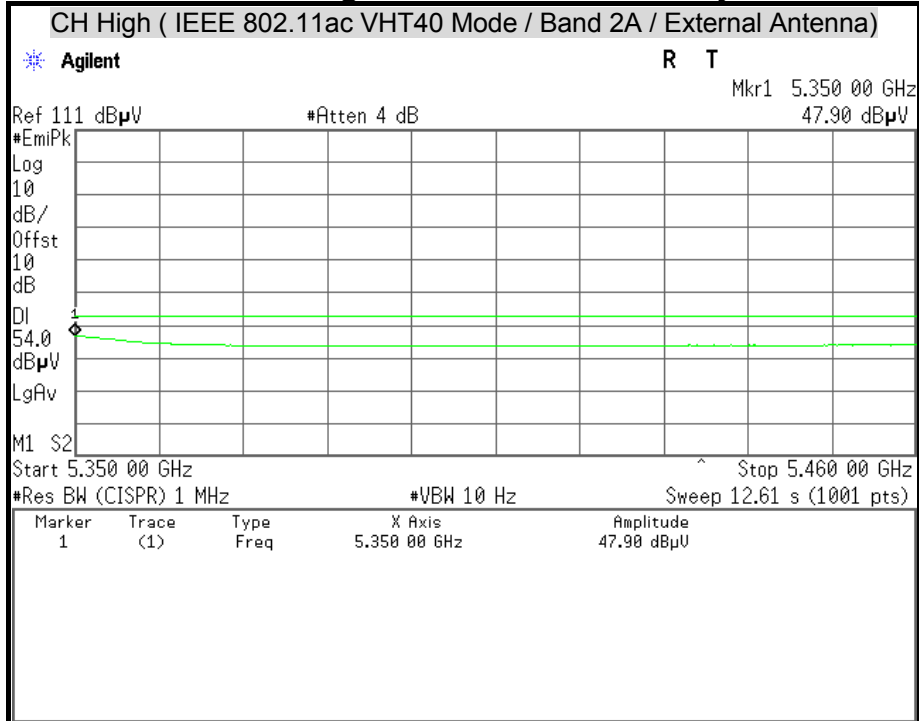



Detector Mode : Peak

Polarity : Vertical

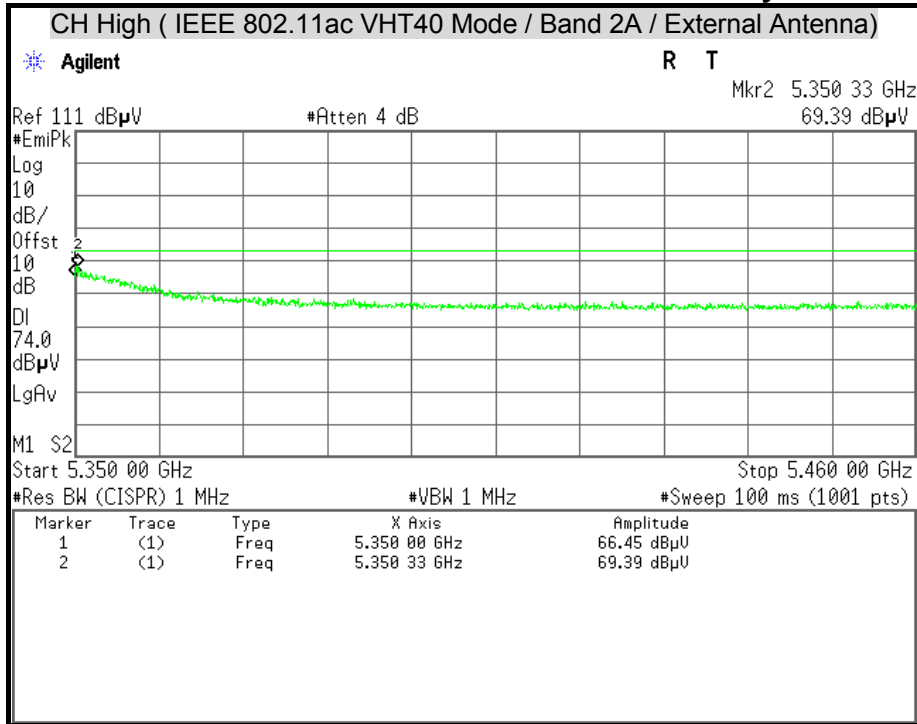

Detector Mode : Average

Polarity : Vertical

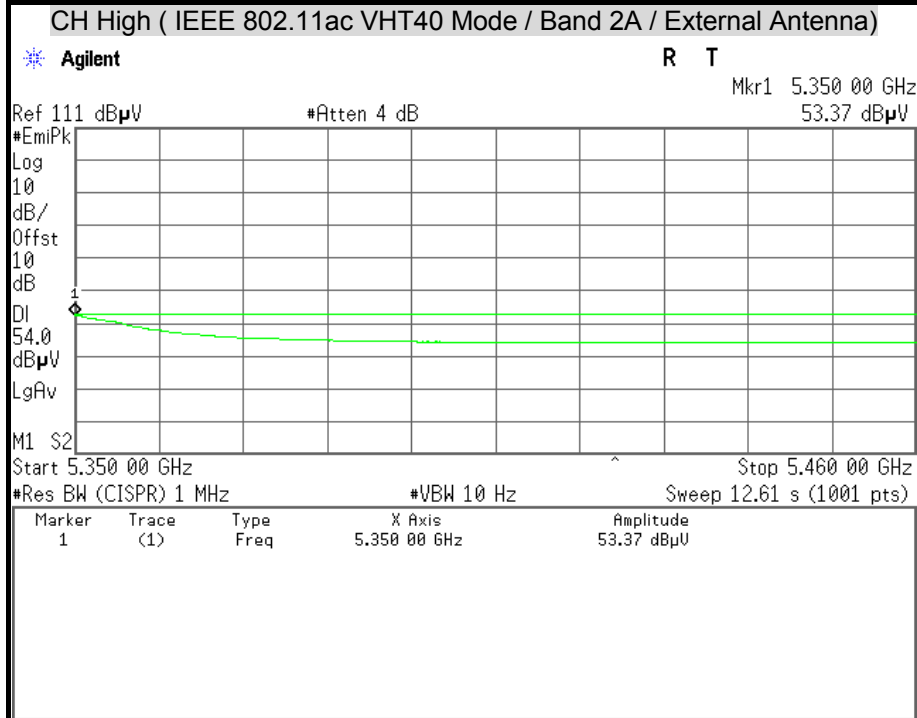



Detector Mode : Peak

Polarity : Horizontal

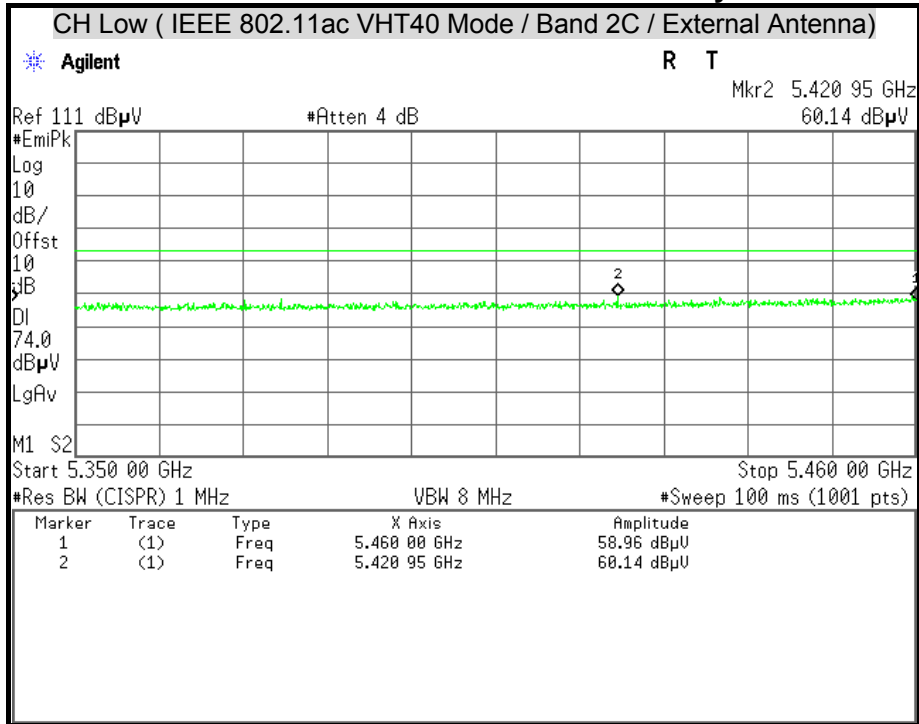

Detector Mode : Average

Polarity : Horizontal

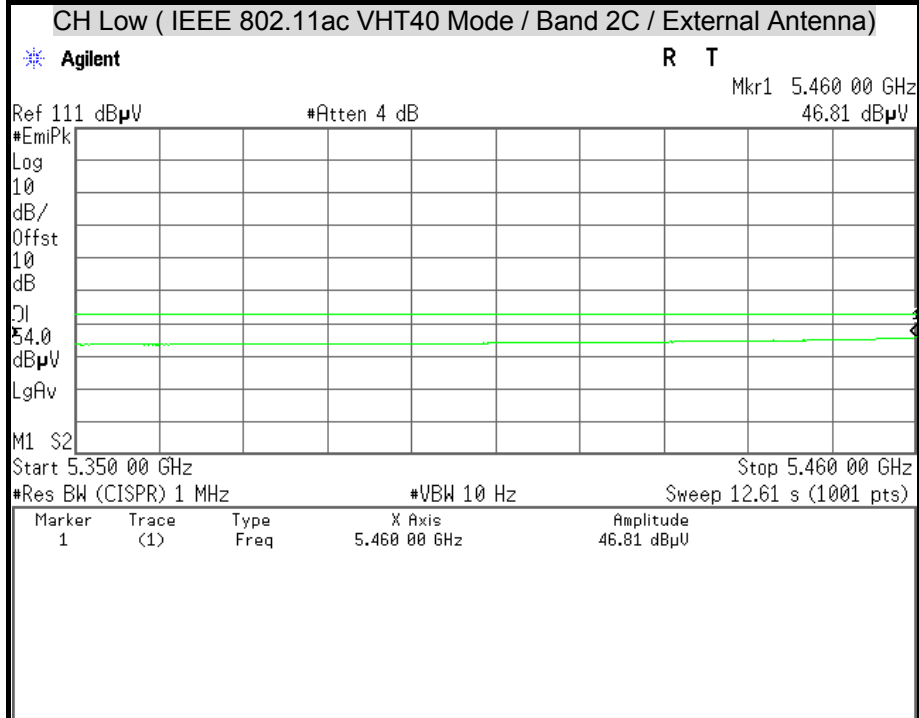



Detector Mode : Peak

Polarity : Vertical

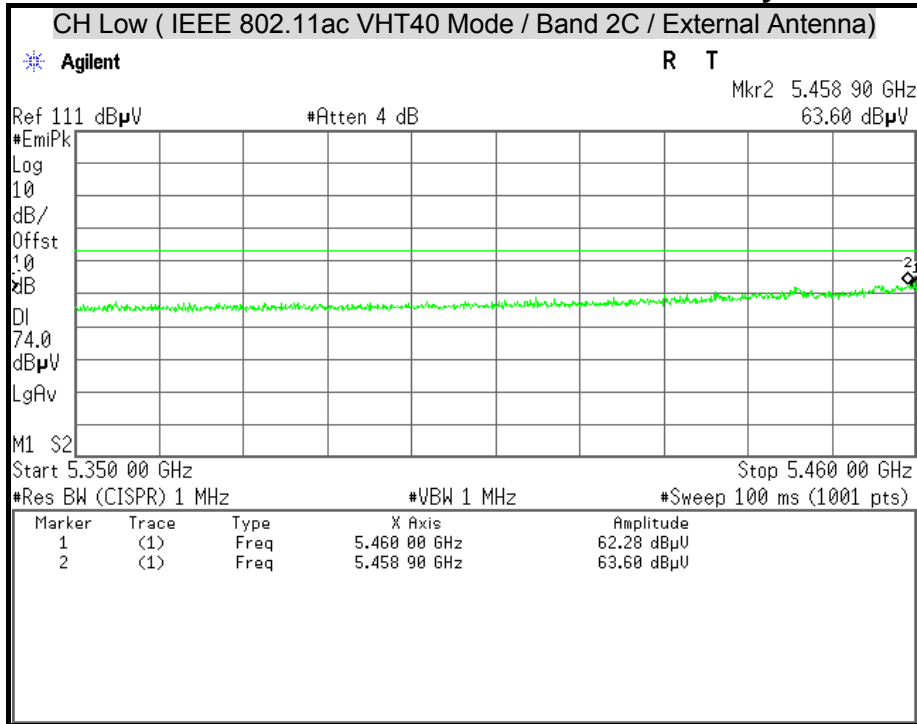

Detector Mode : Average

Polarity : Vertical

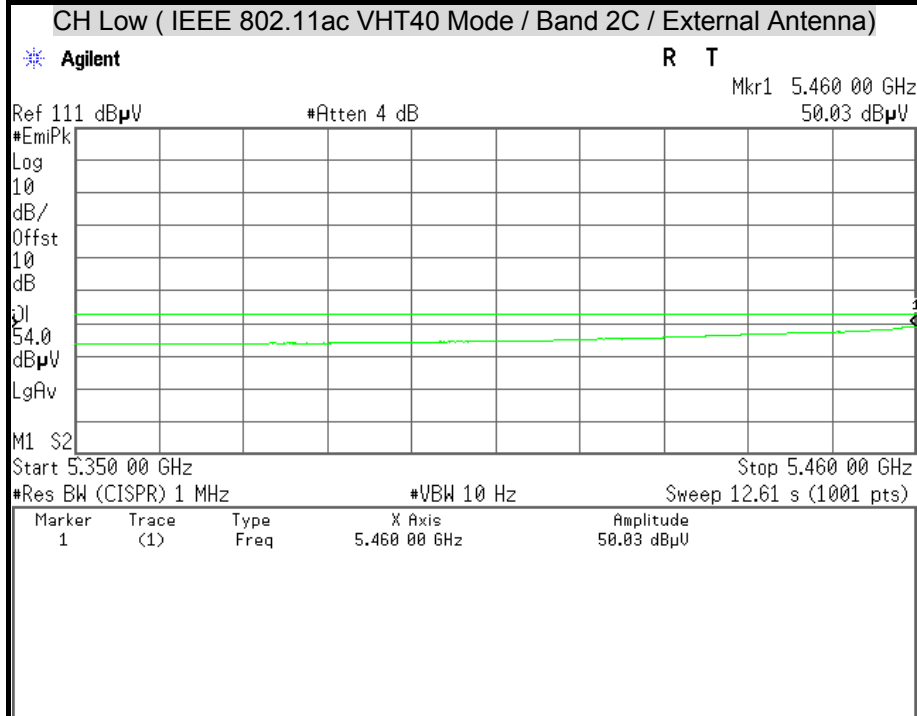



Detector Mode : Peak

Polarity : Horizontal

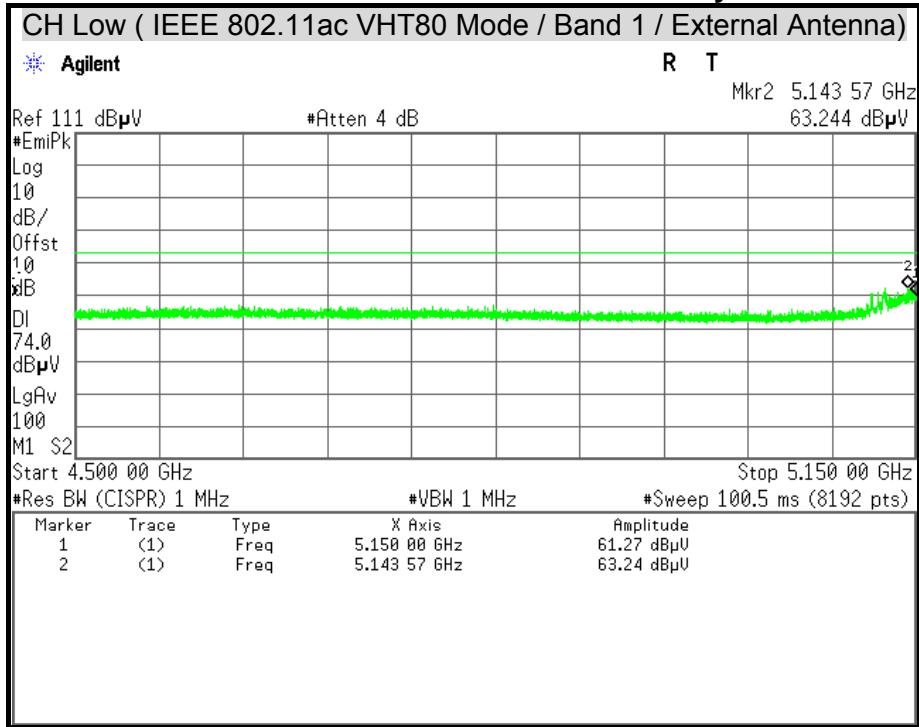

Detector Mode : Average

Polarity : Horizontal

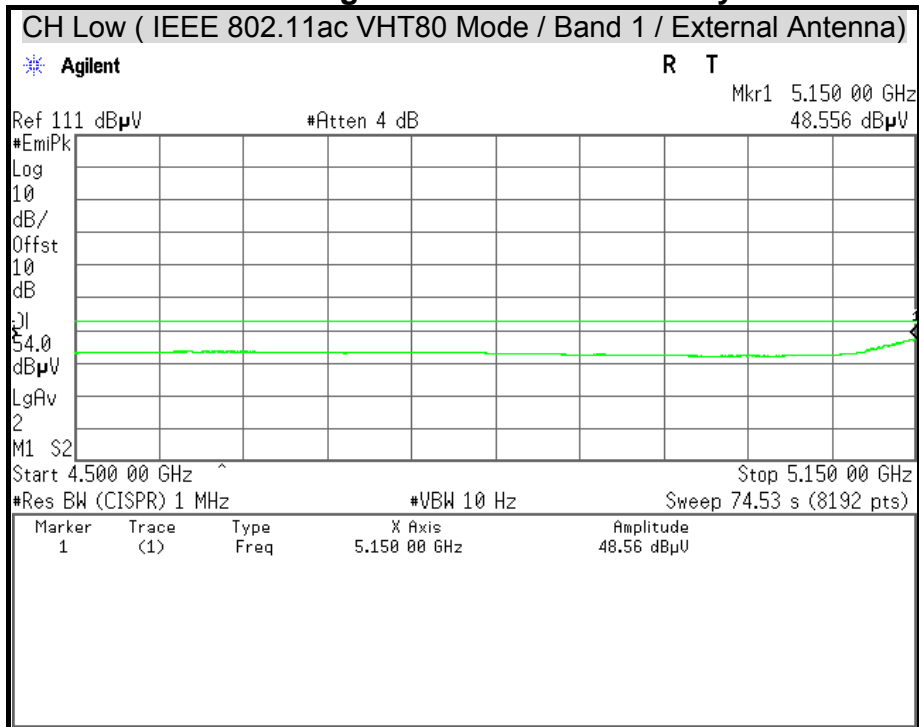



Detector Mode : Peak

Polarity : Vertical

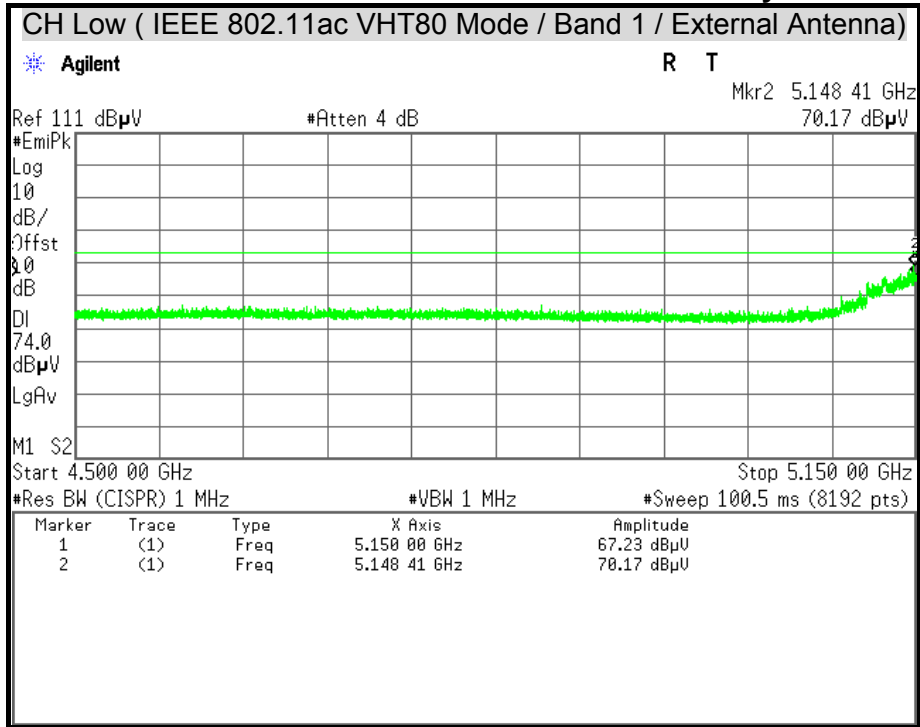

Detector Mode : Average

Polarity : Vertical

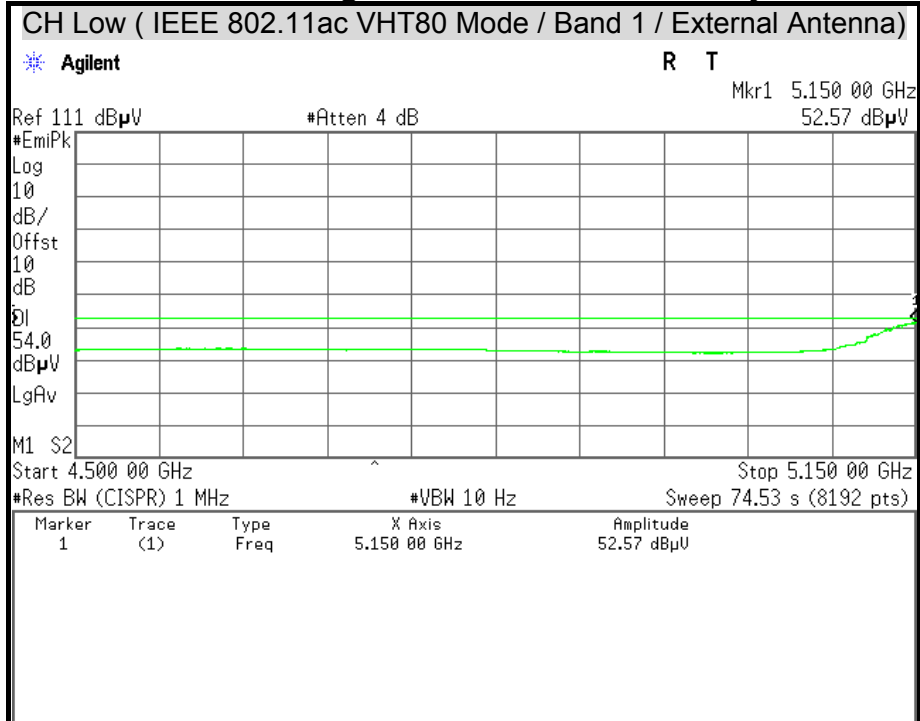



Detector Mode : Peak

Polarity : Horizontal

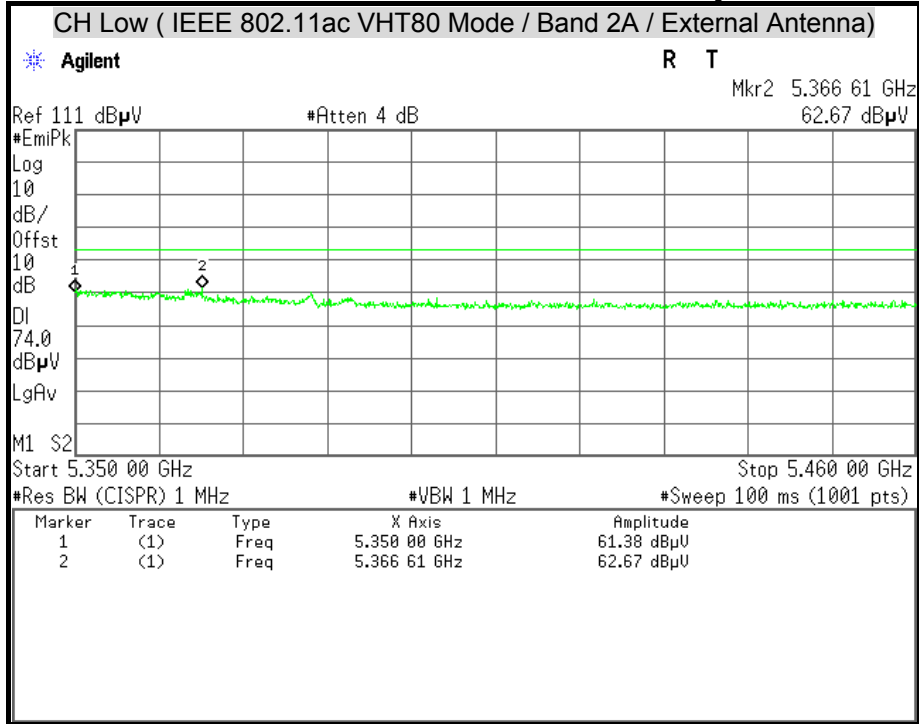

Detector Mode : Average

Polarity : Horizontal

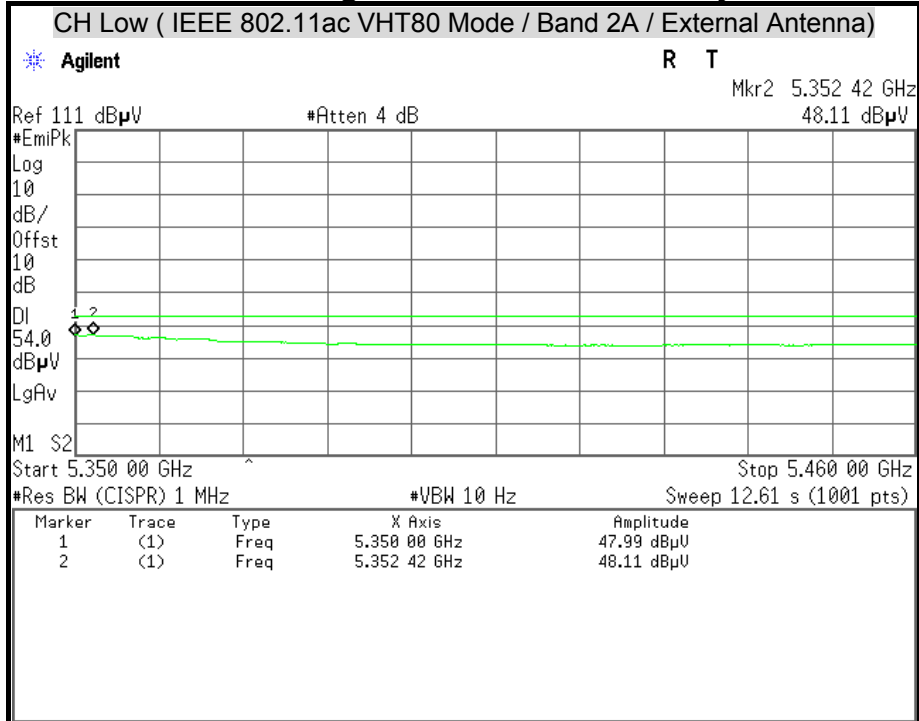



Detector Mode : Peak

Polarity : Vertical

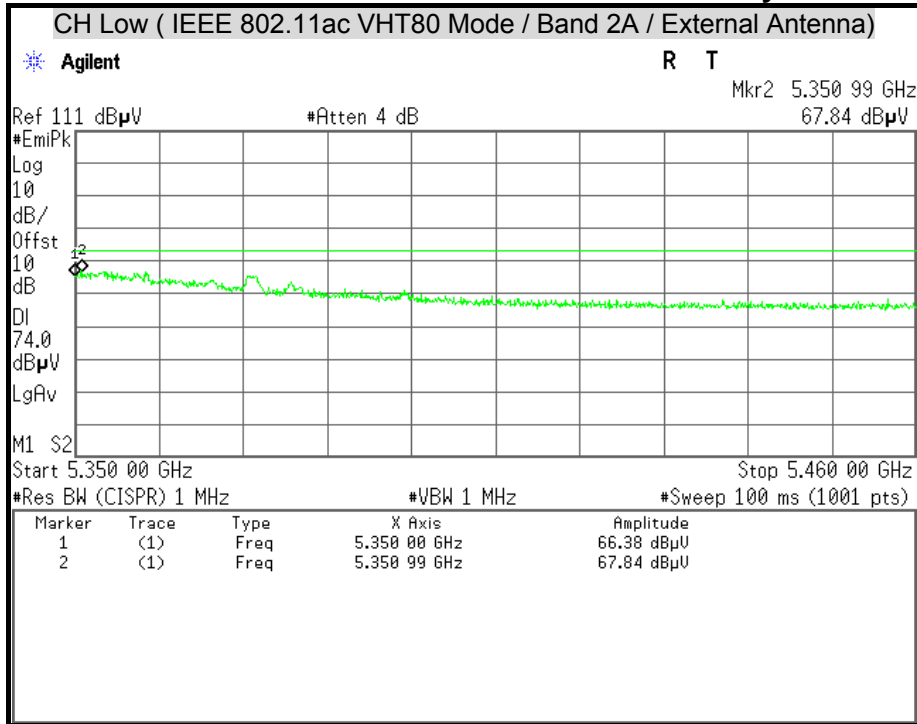

Detector Mode : Average

Polarity : Vertical

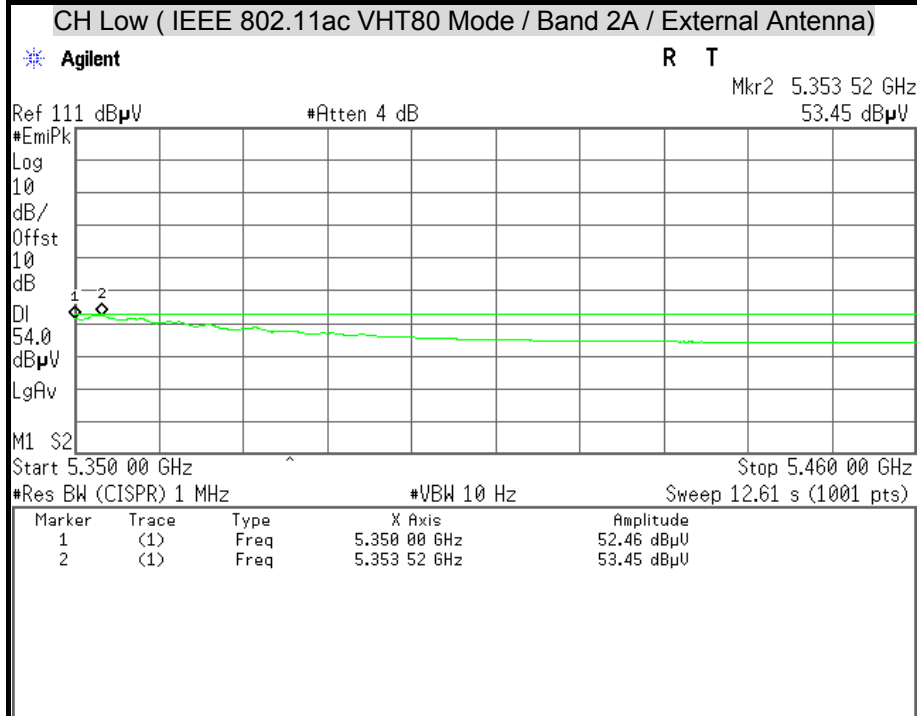



Detector Mode : Peak

Polarity : Horizontal

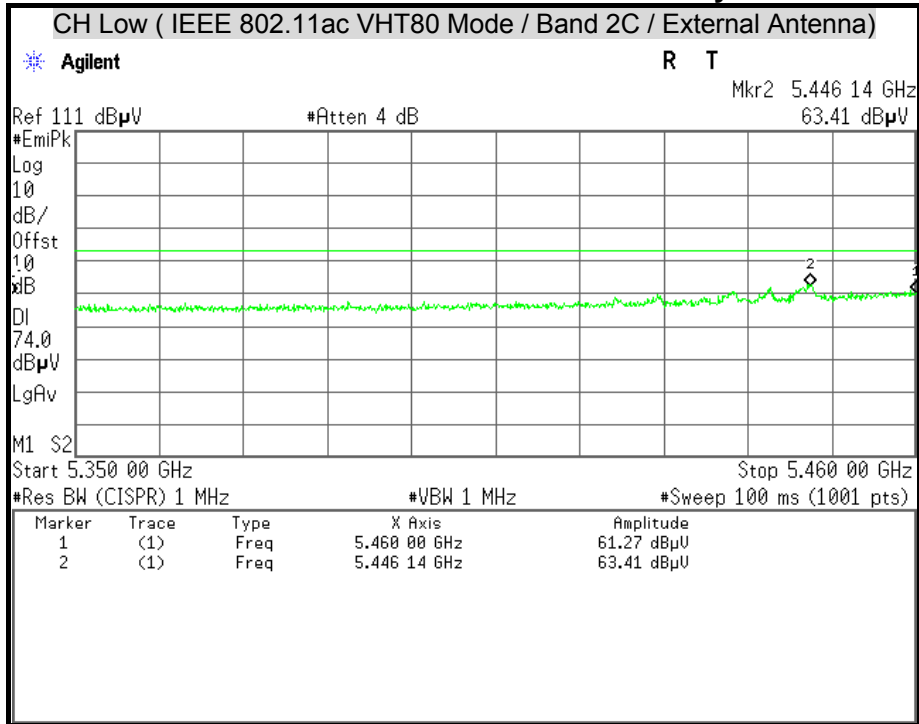

Detector Mode : Average

Polarity : Horizontal

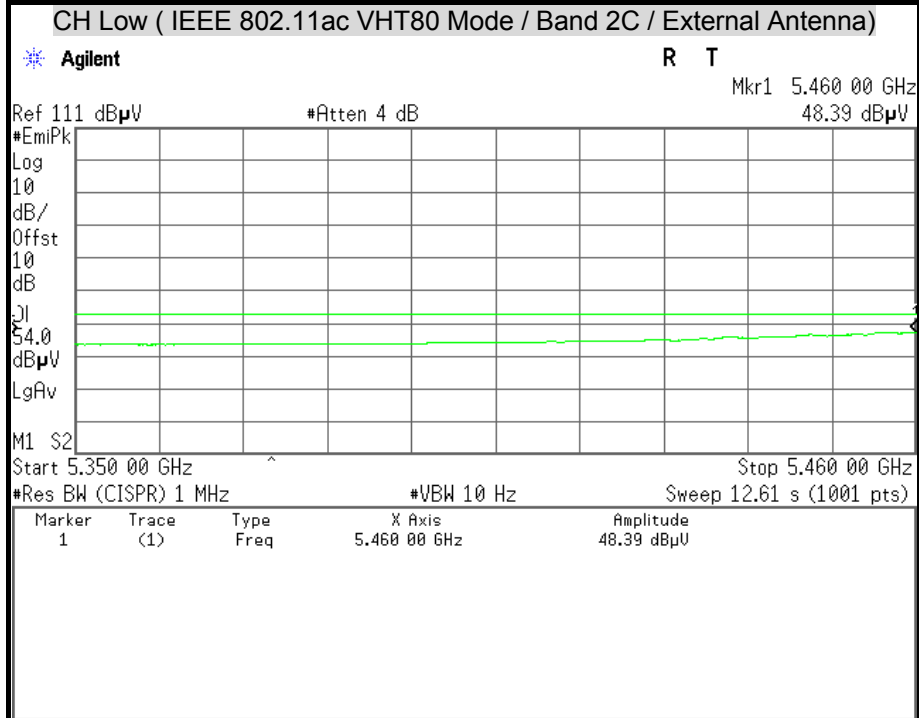



Detector Mode : Peak

Polarity : Vertical

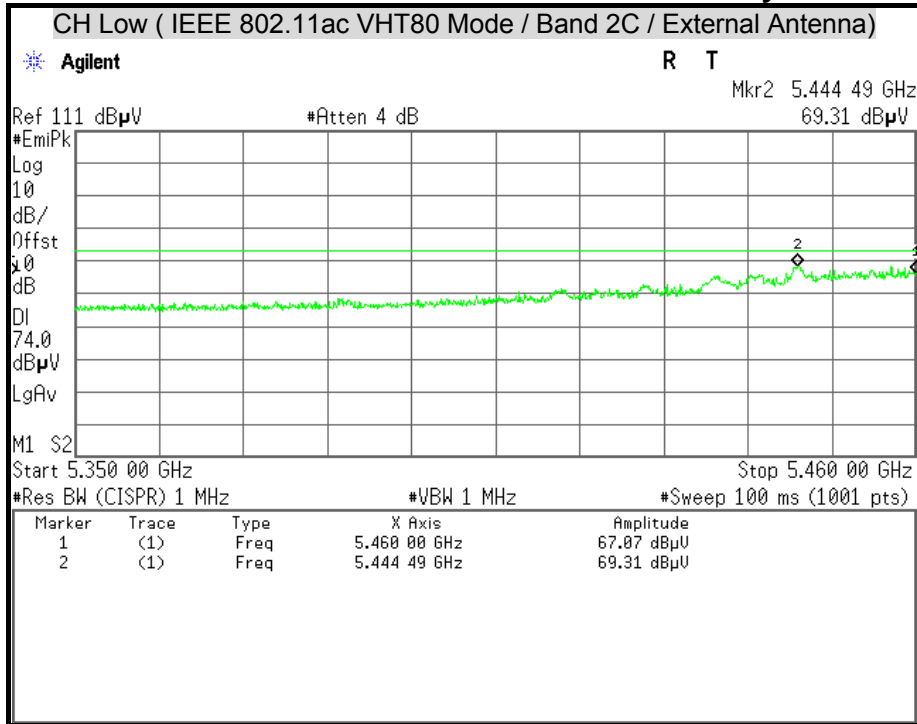

Detector Mode : Average

Polarity : Vertical

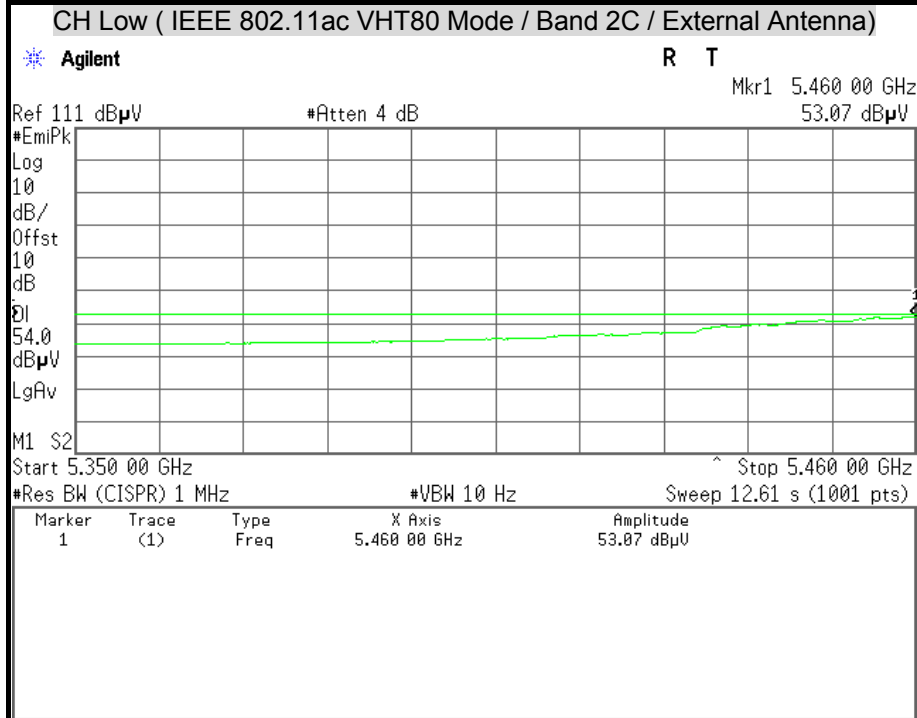



Detector Mode : Peak Polarity : Horizontal

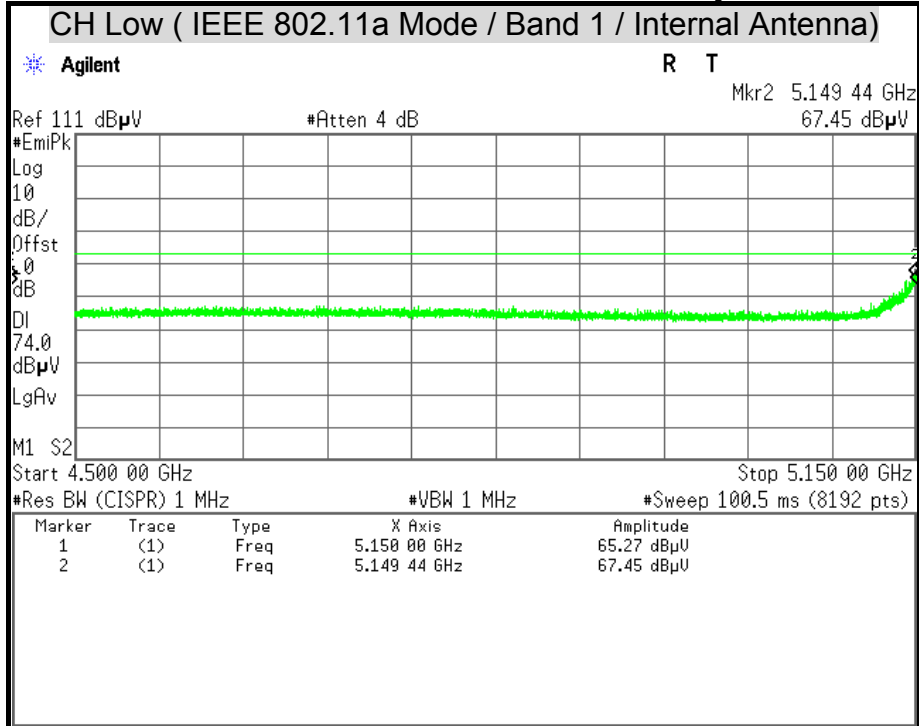

Detector Mode : Average Polarity : Horizontal

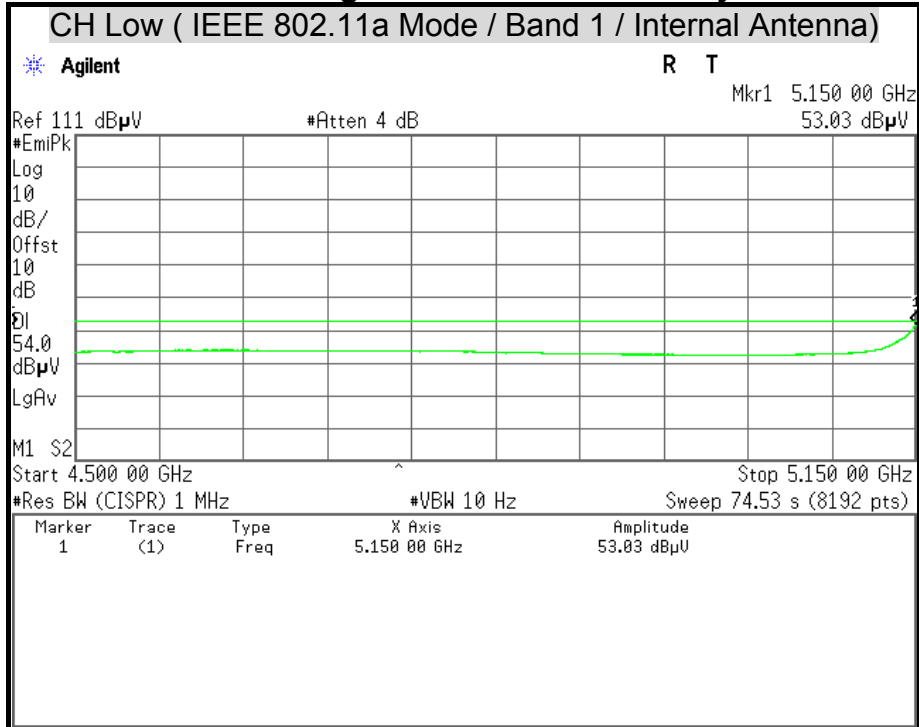



Detector Mode : Peak

Polarity : Vertical

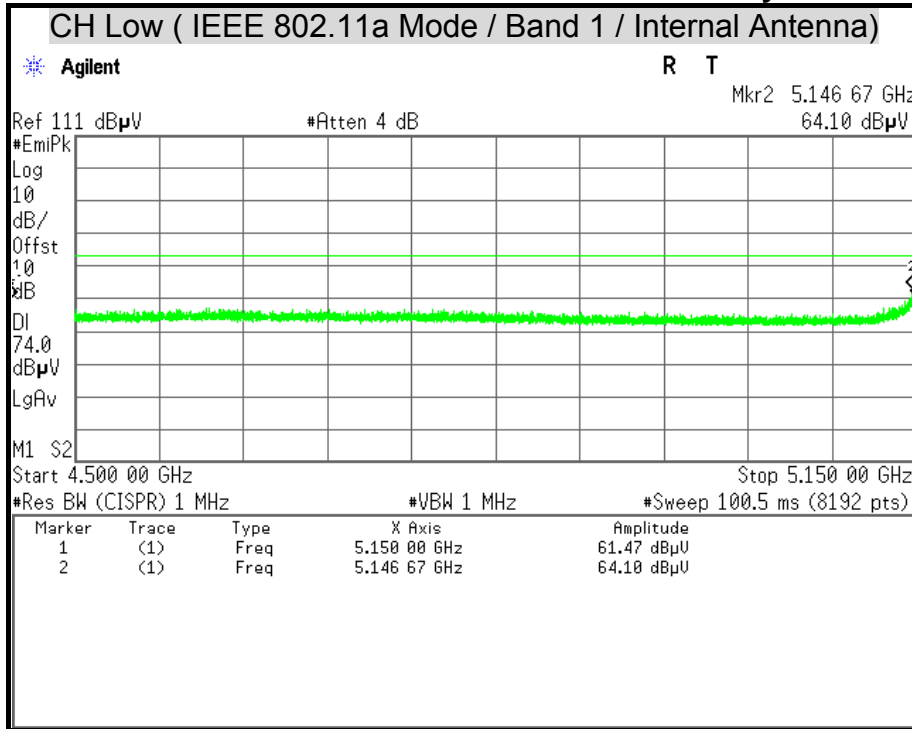

Detector Mode : Average

Polarity : Vertical

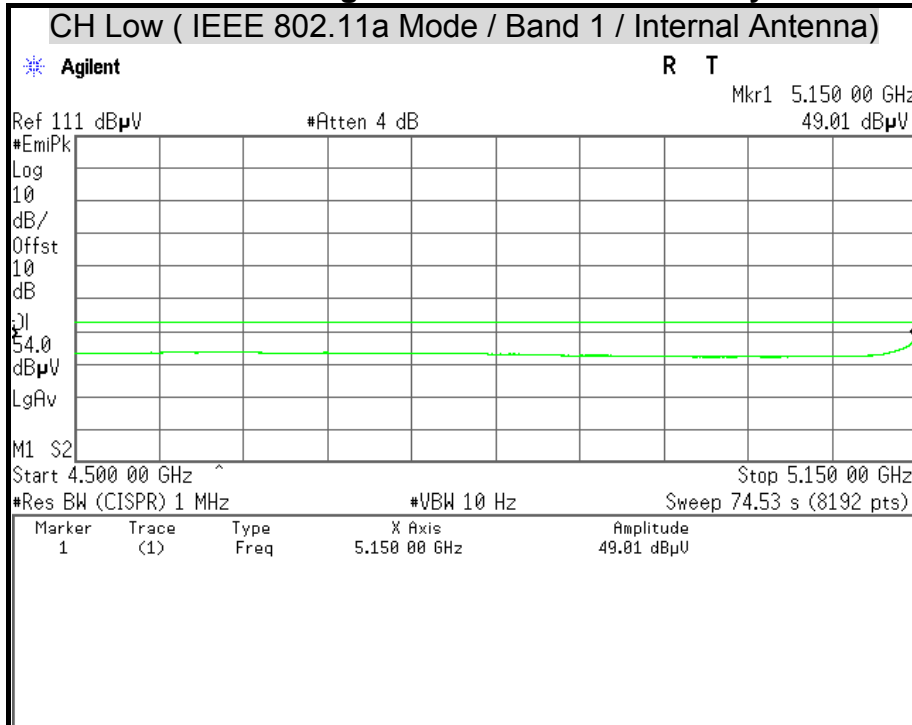



Detector Mode : Peak

Polarity : Horizontal

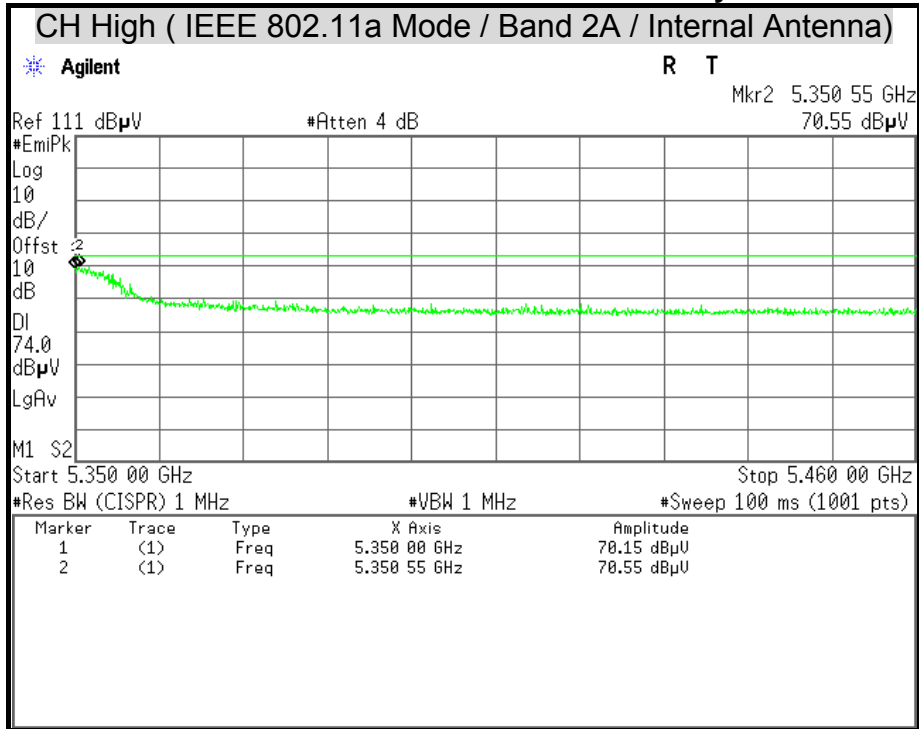

Detector Mode : Average

Polarity : Horizontal

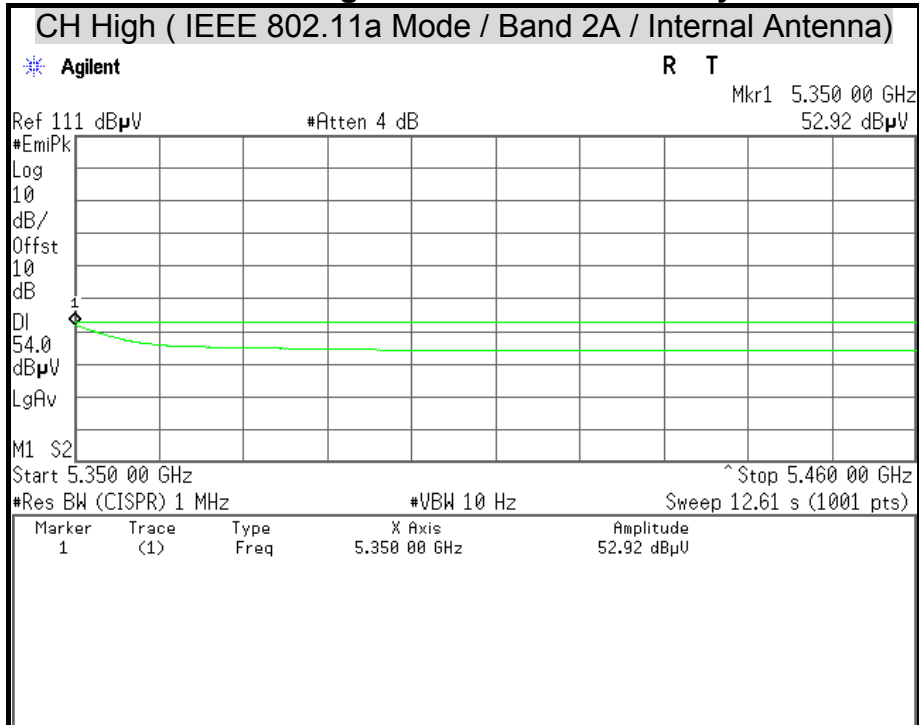



Detector Mode : Peak

Polarity : Vertical

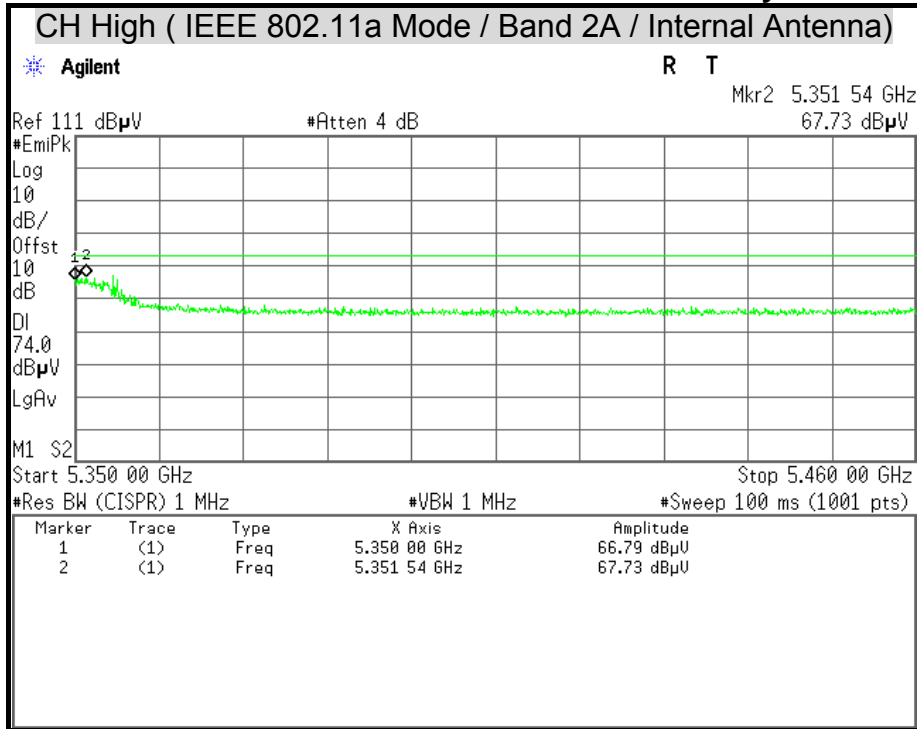

Detector Mode : Average

Polarity : Vertical

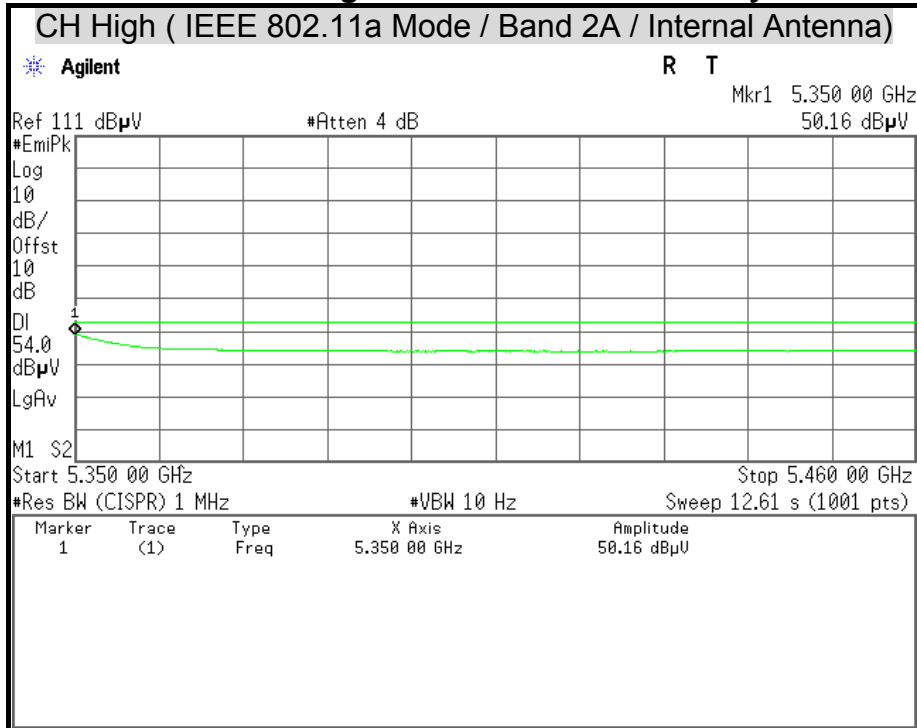



Detector Mode : Peak

Polarity : Horizontal

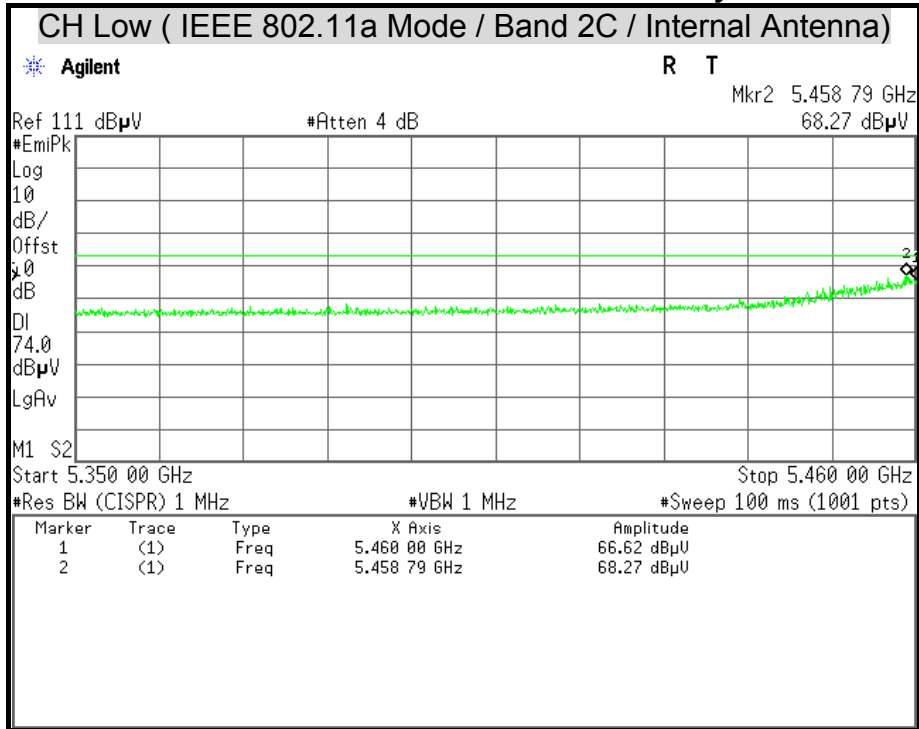

Detector Mode : Average

Polarity : Horizontal

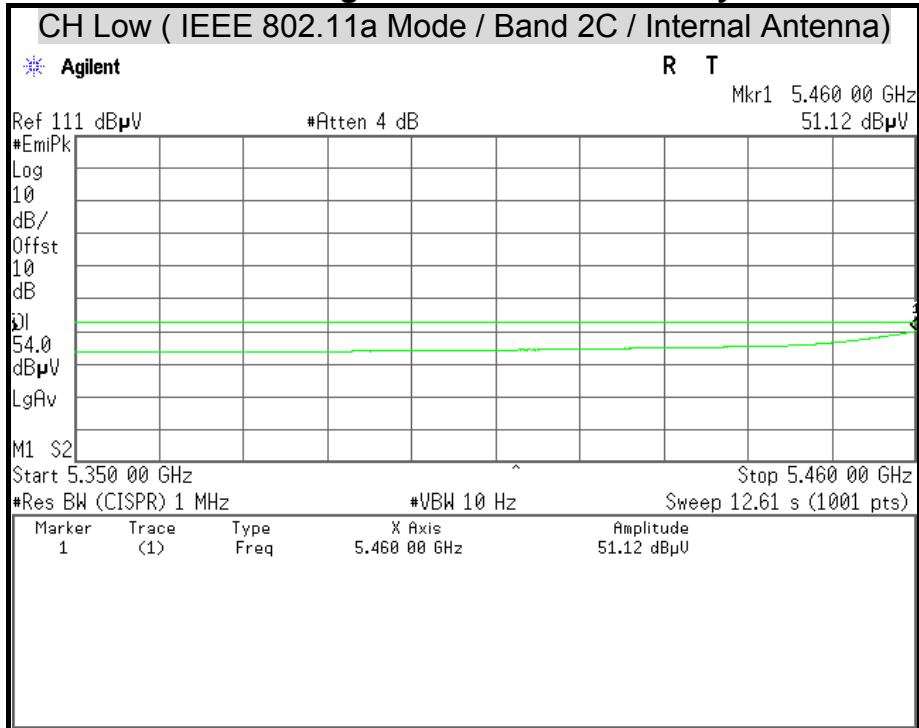



Detector Mode : Peak

Polarity : Vertical

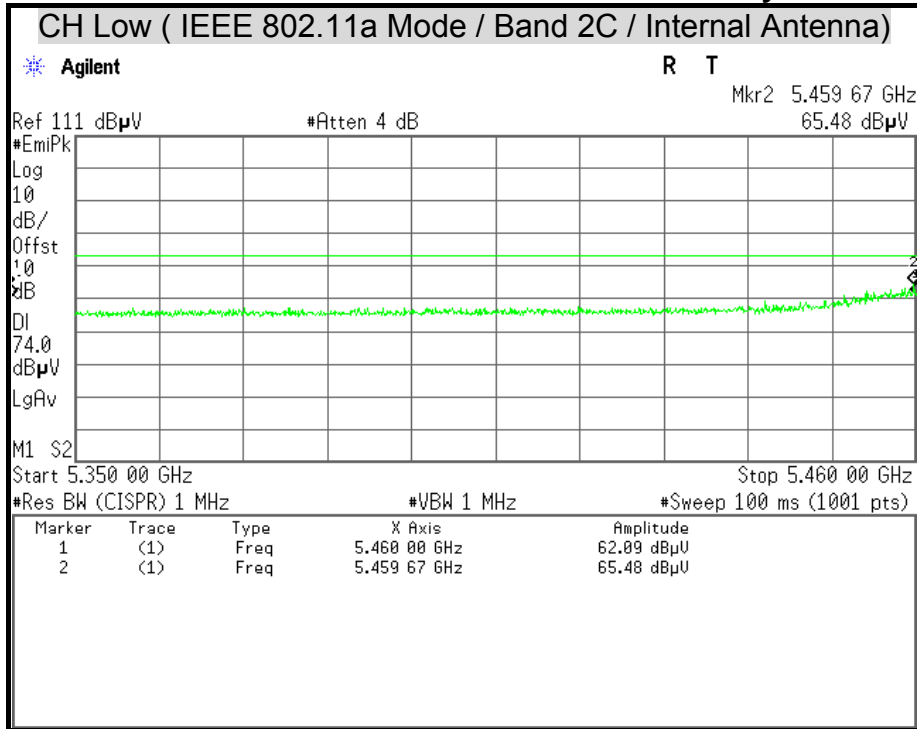

Detector Mode : Average

Polarity : Vertical

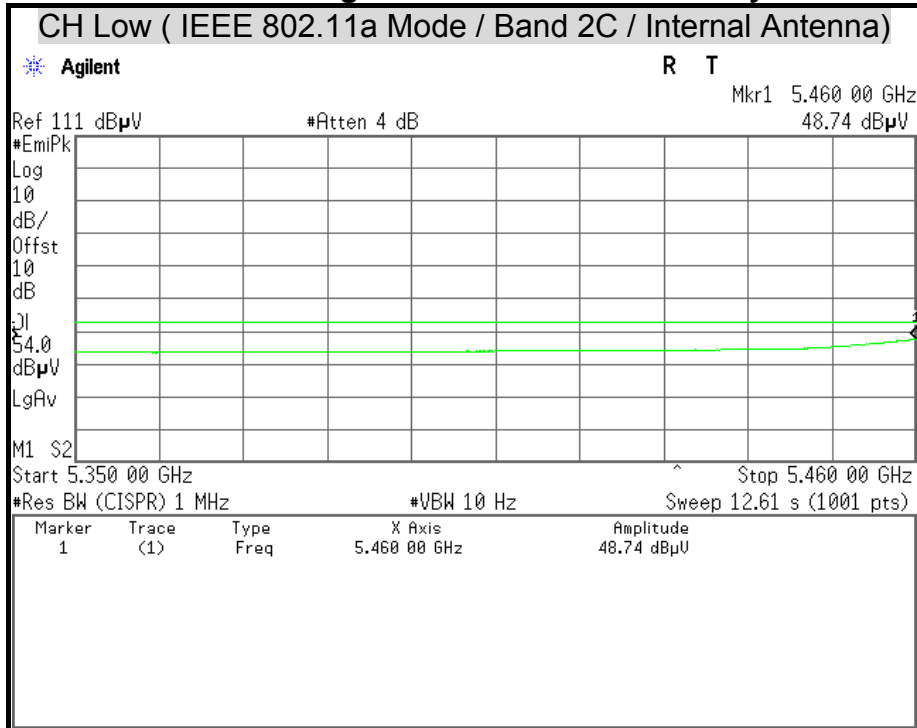



Detector Mode : Peak

Polarity : Horizontal

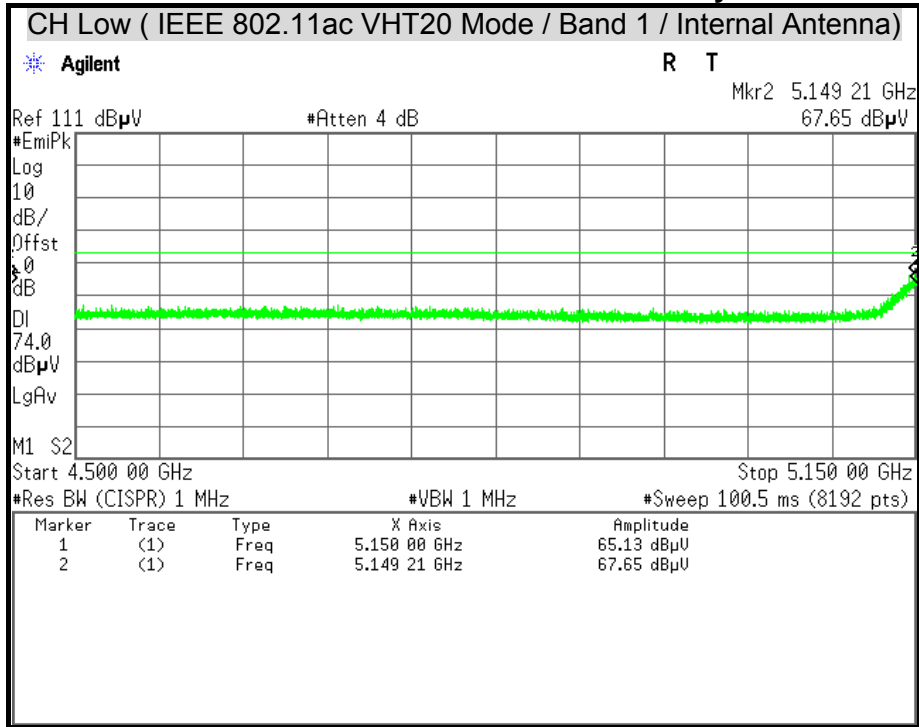

Detector Mode : Average

Polarity : Horizontal

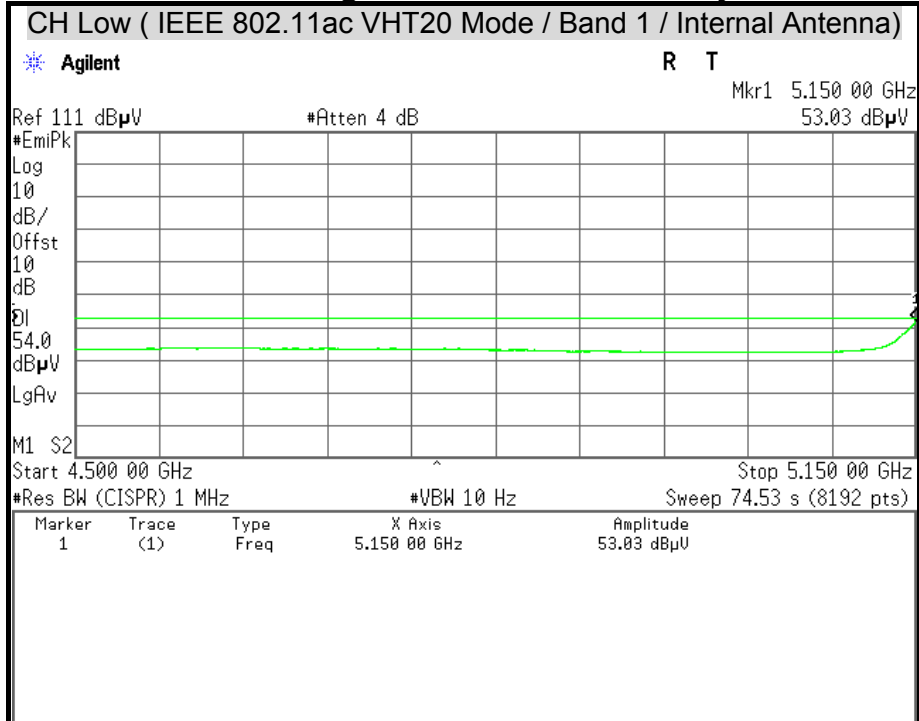



Detector Mode : Peak

Polarity : Vertical

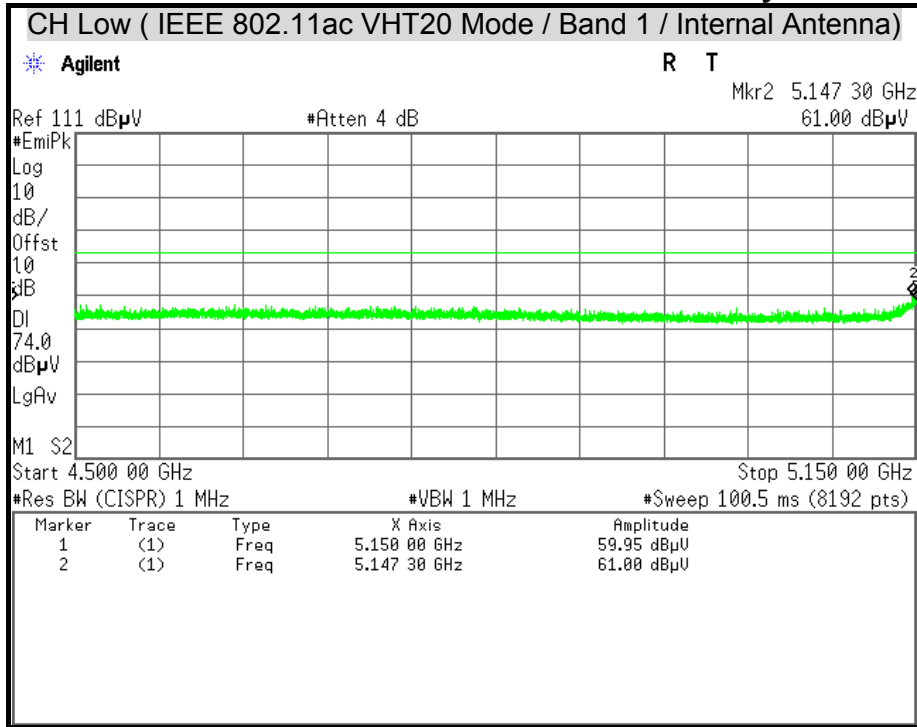

Detector Mode : Average

Polarity : Vertical

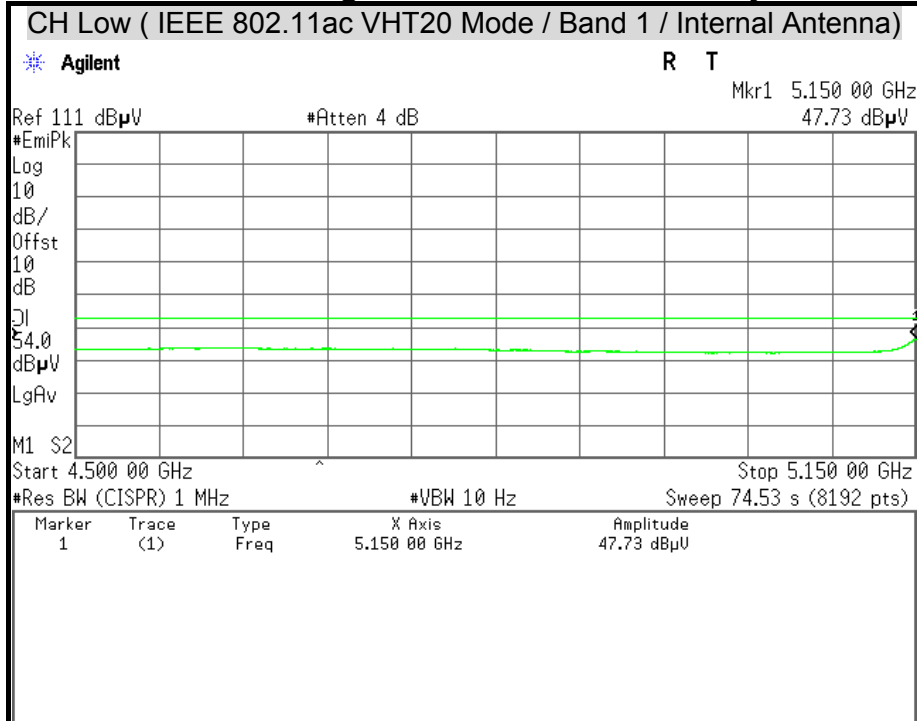



Detector Mode : Peak

Polarity : Horizontal

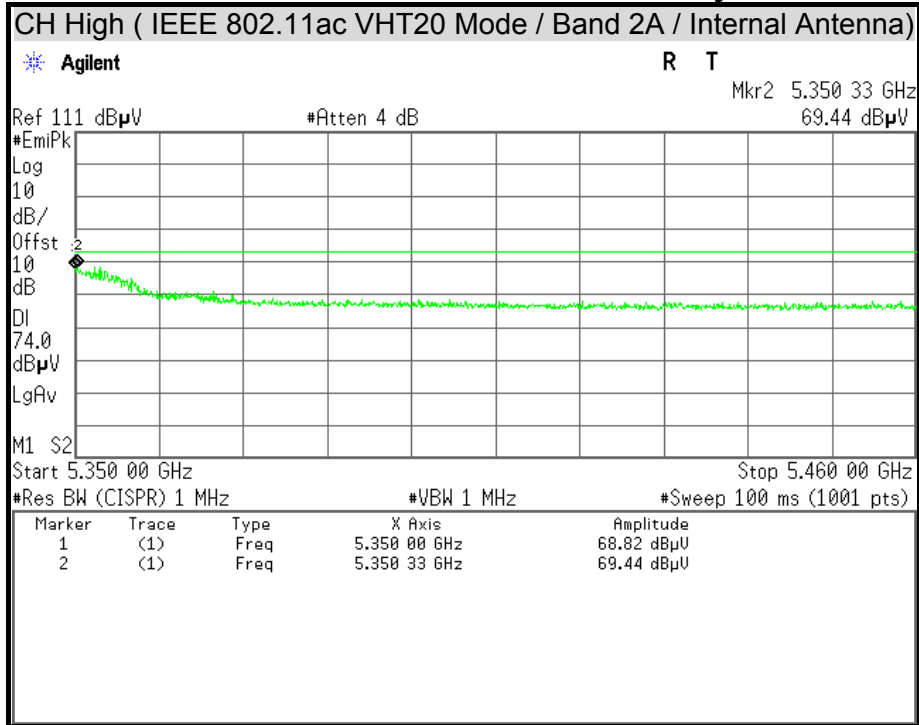

Detector Mode : Average

Polarity : Horizontal

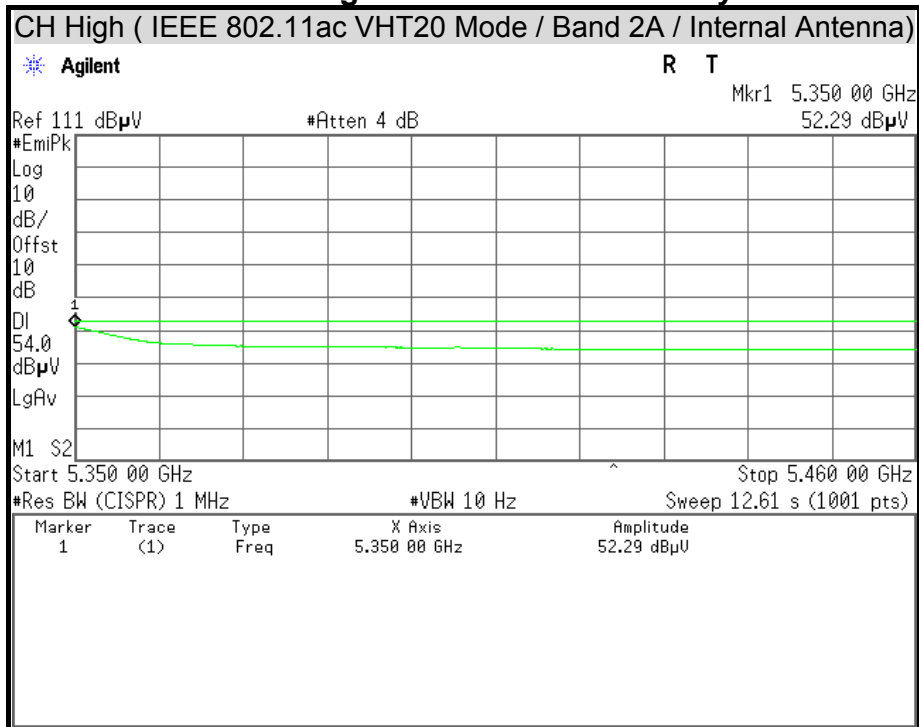



Detector Mode : Peak

Polarity : Vertical

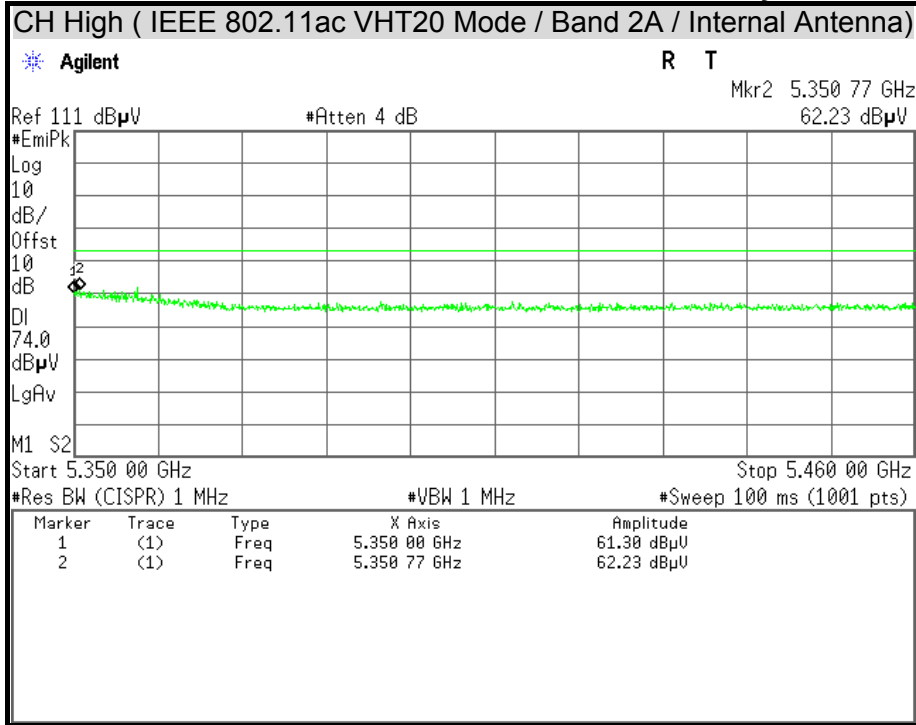

Detector Mode : Average

Polarity : Vertical

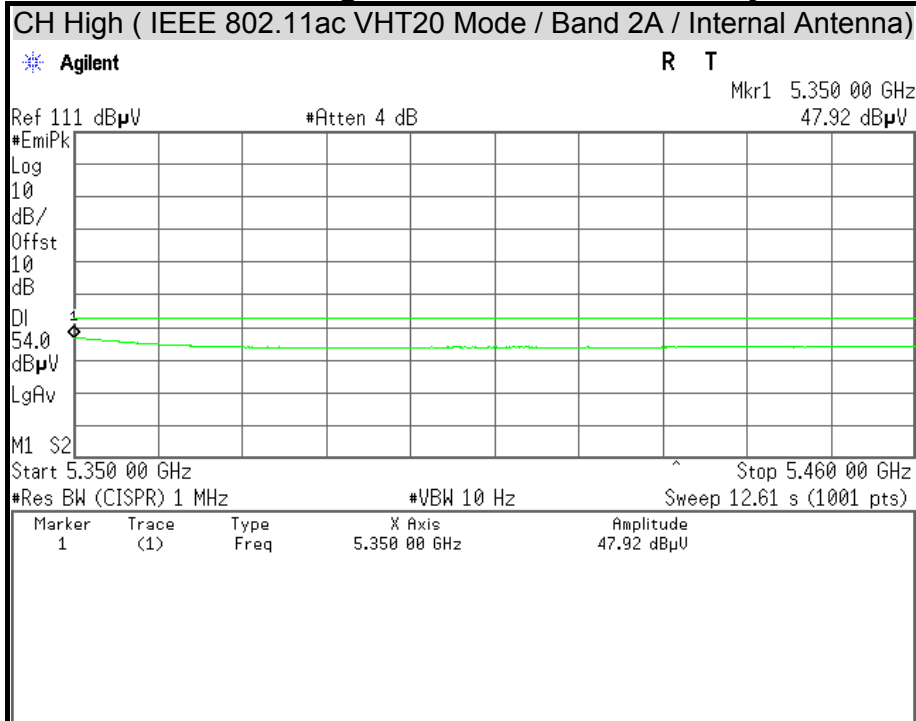



Detector Mode : Peak

Polarity : Horizontal

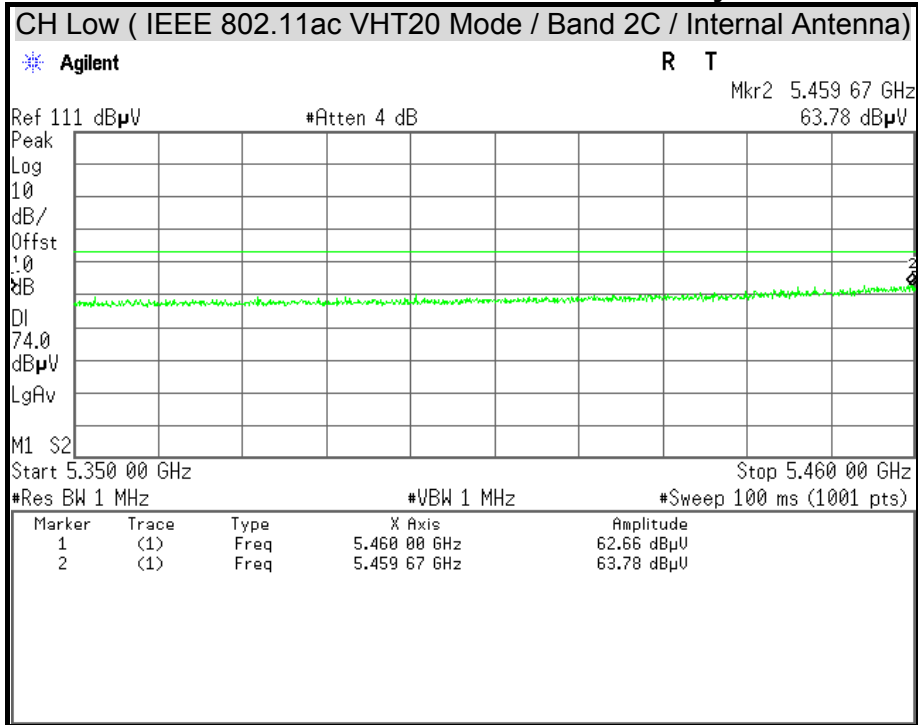

Detector Mode : Average

Polarity : Horizontal

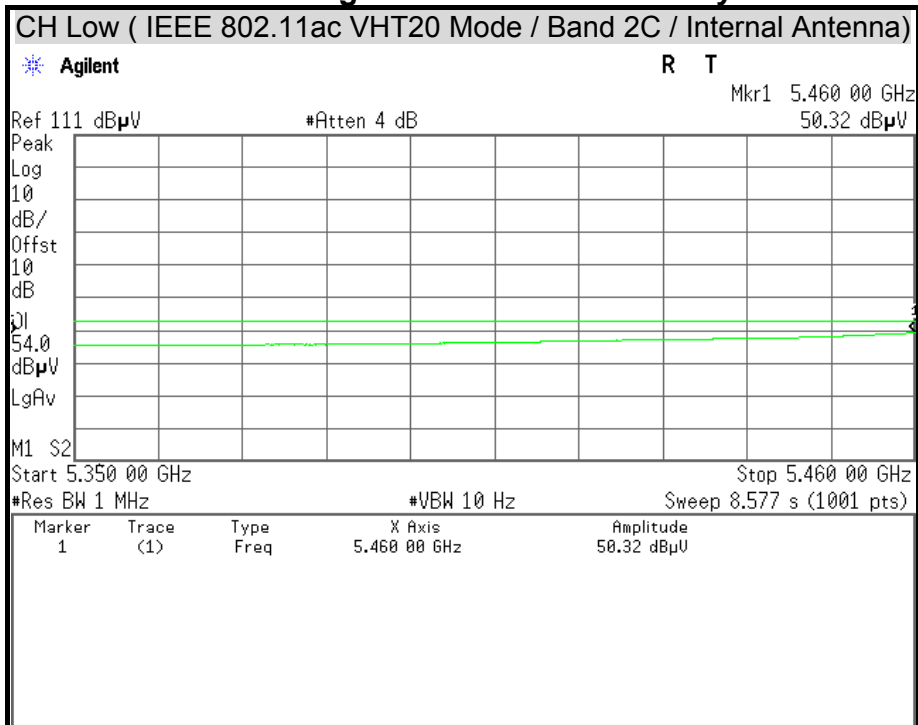



Detector Mode : Peak

Polarity : Vertical

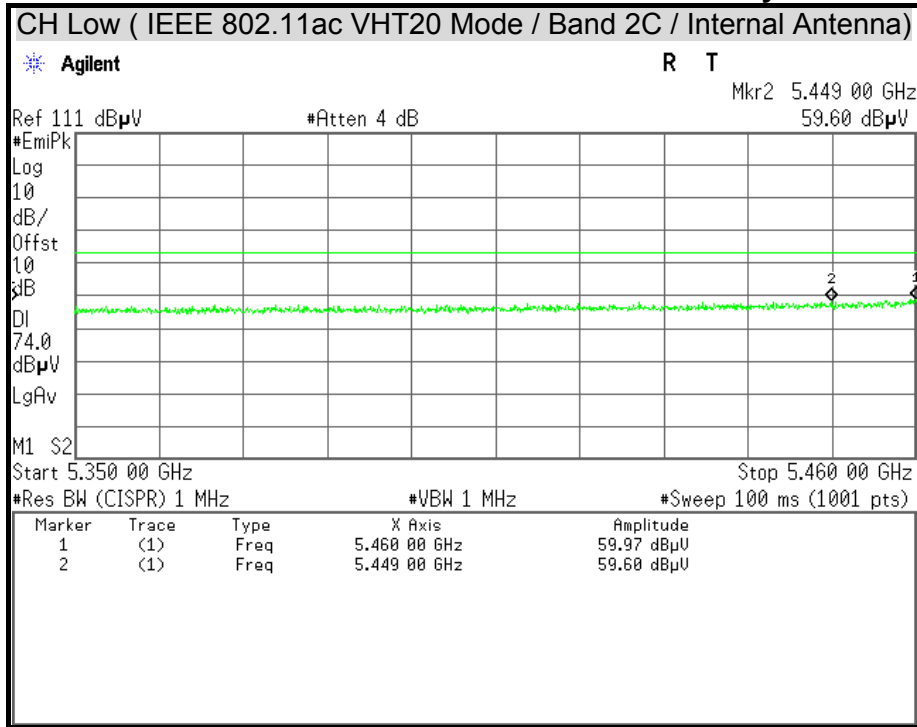

Detector Mode : Average

Polarity : Vertical

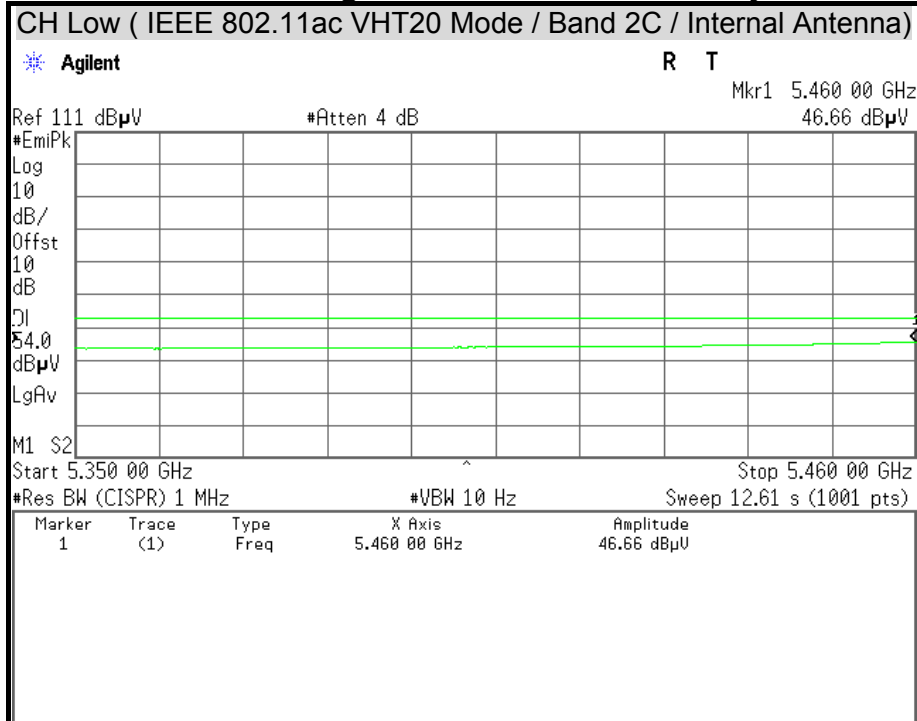



Detector Mode : Peak

Polarity : Horizontal

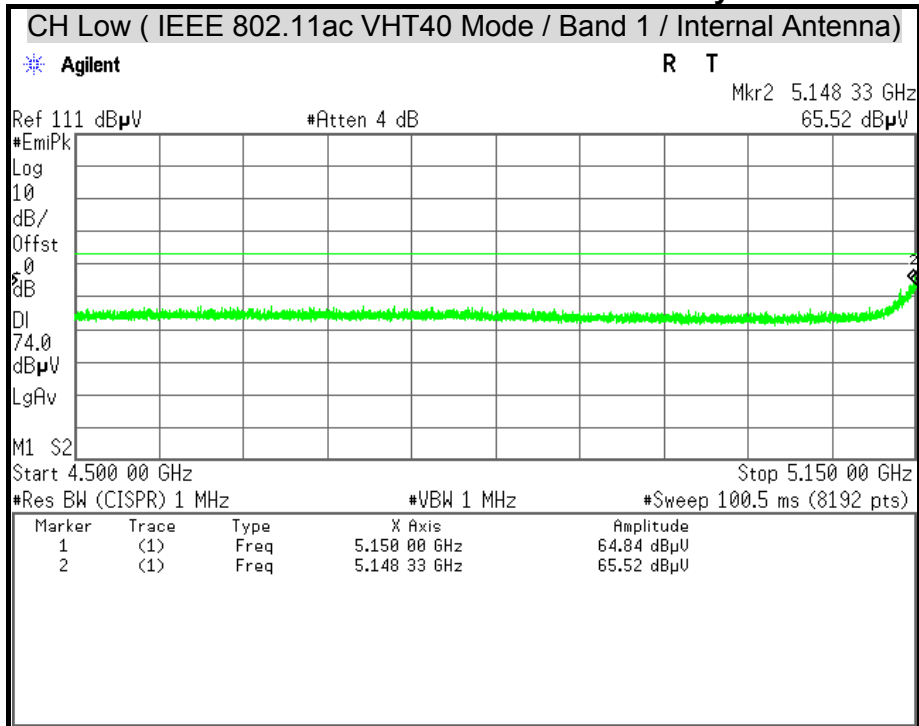

Detector Mode : Average

Polarity : Horizontal

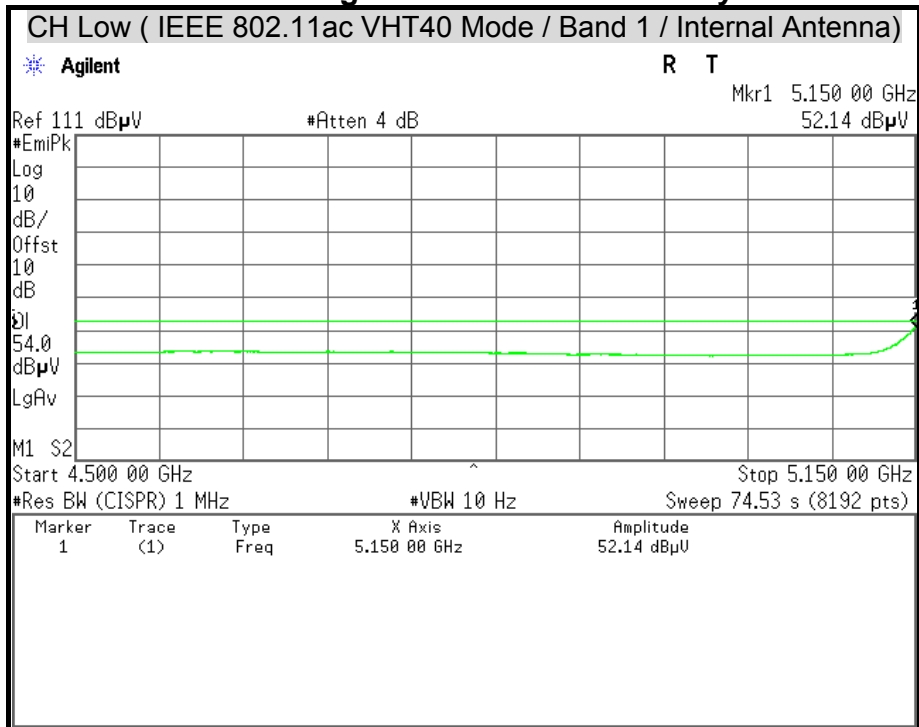



Detector Mode : Peak

Polarity : Vertical

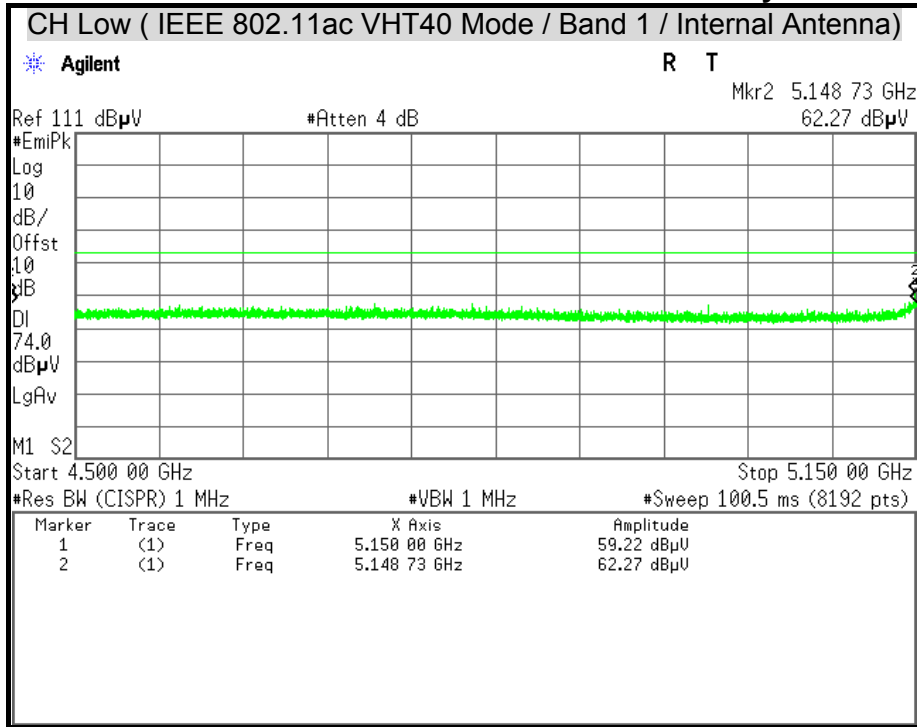

Detector Mode : Average

Polarity : Vertical

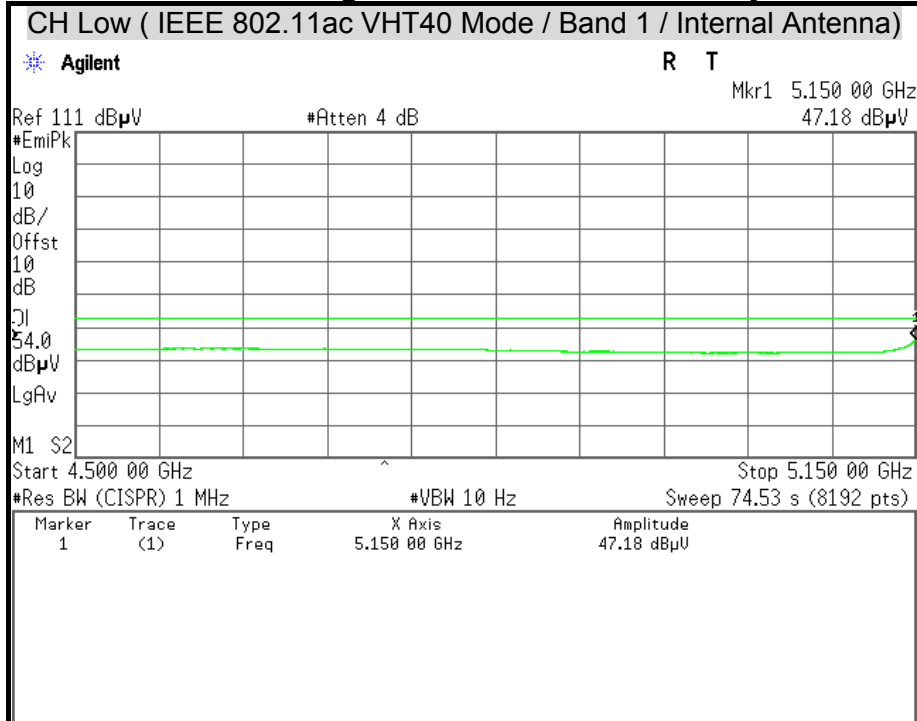



Detector Mode : Peak Polarity : Horizontal

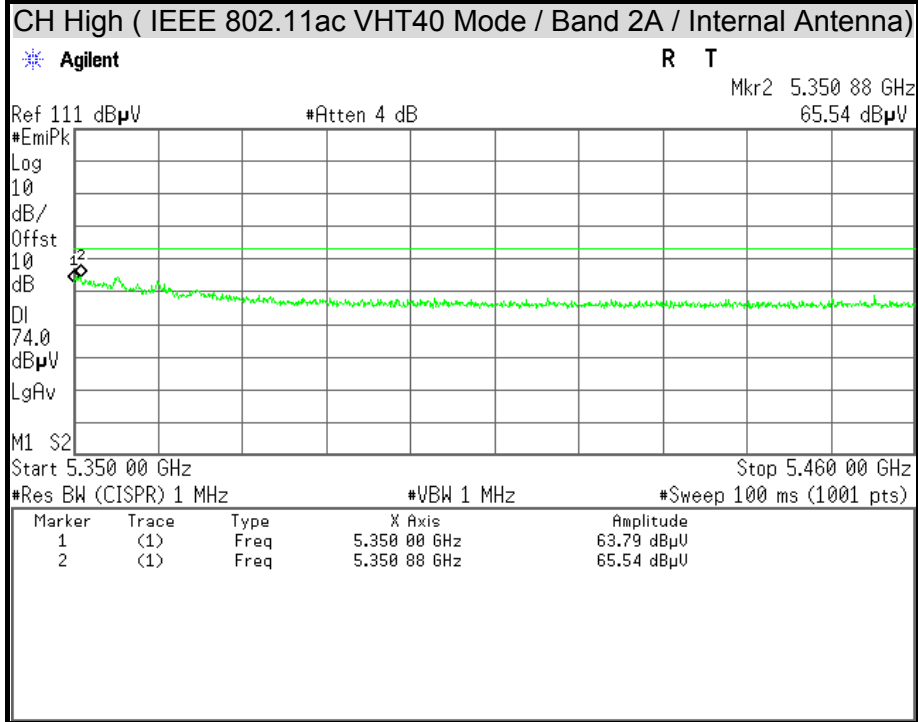

Detector Mode : Average Polarity : Horizontal

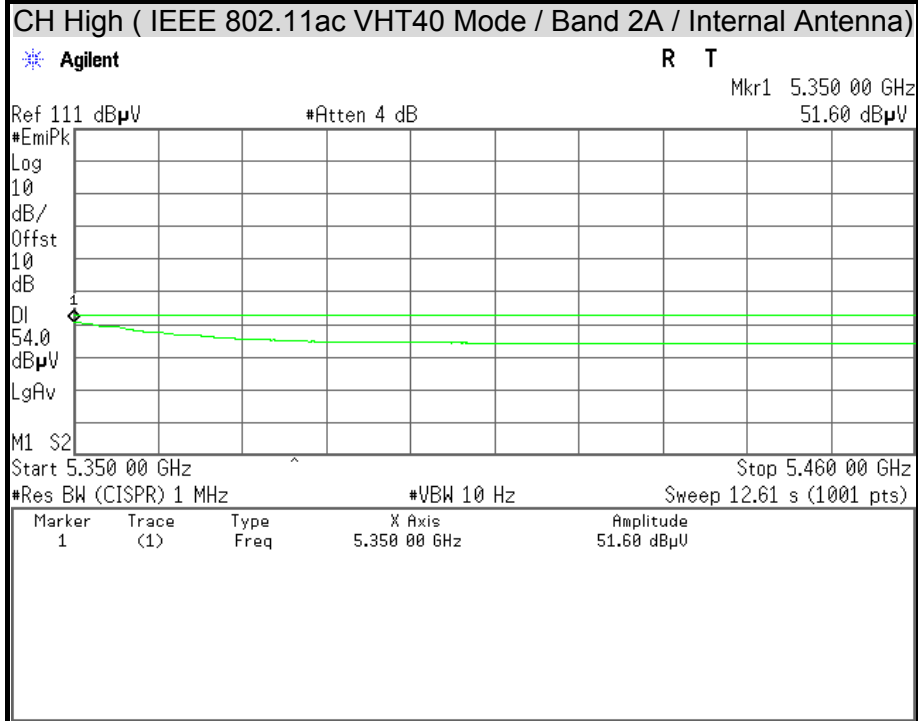



Detector Mode : Peak

Polarity : Vertical

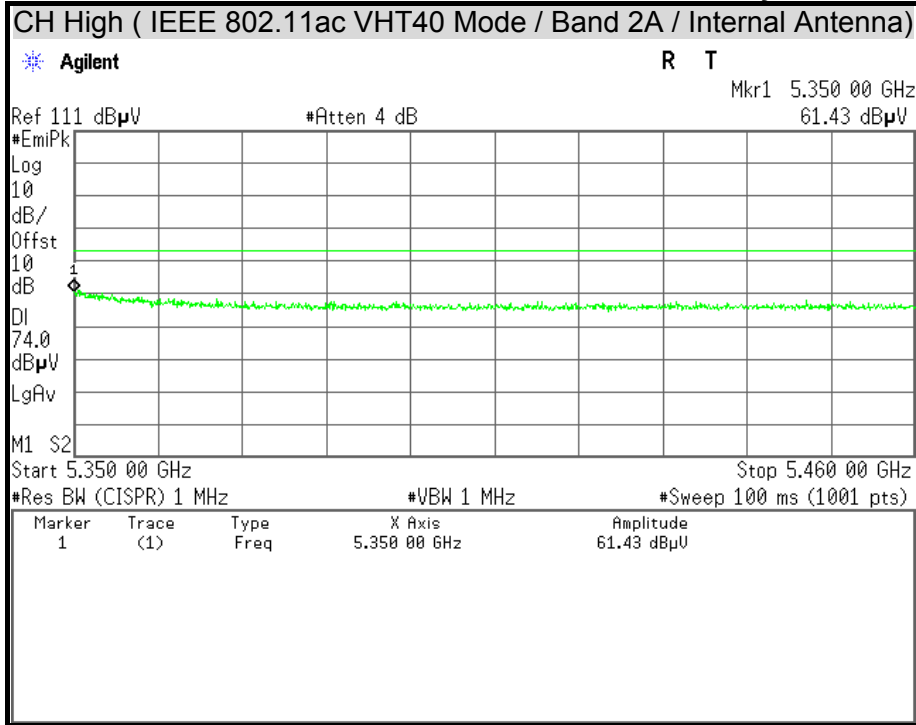

Detector Mode : Average

Polarity : Vertical

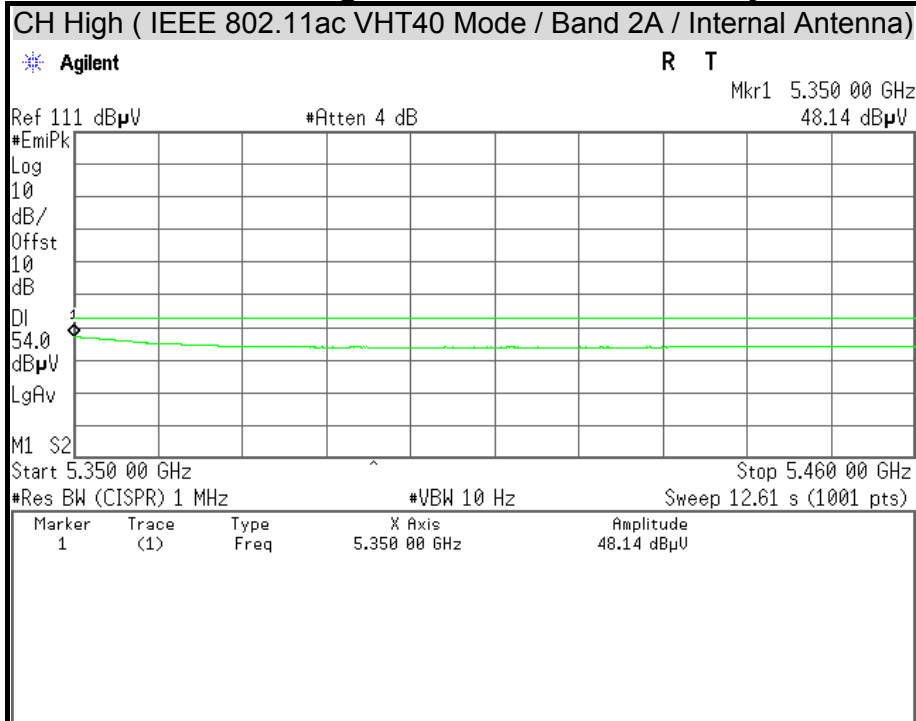



Detector Mode : Peak

Polarity : Horizontal

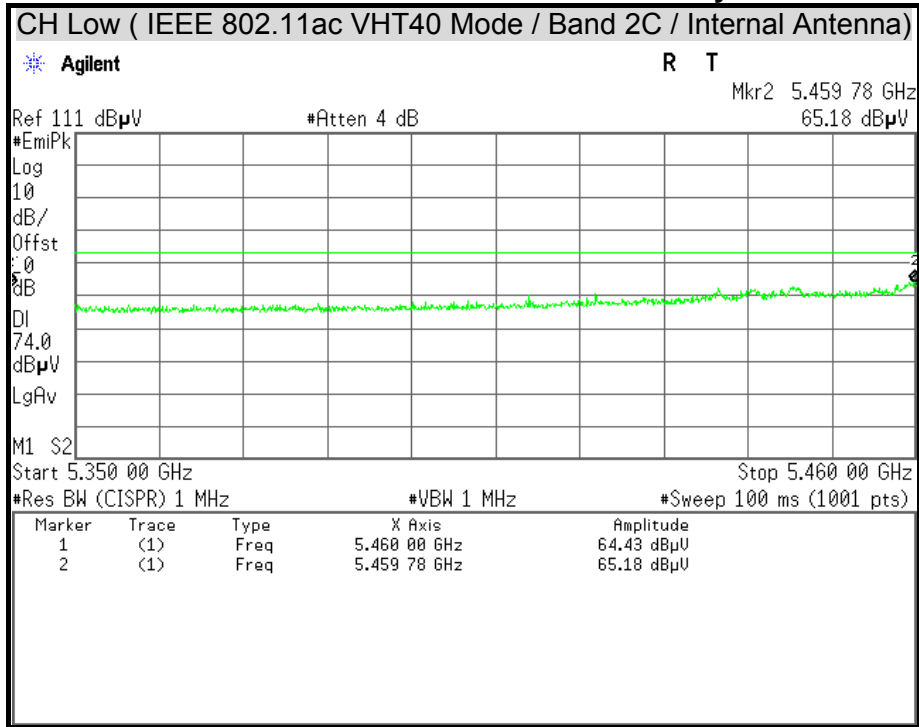

Detector Mode : Average

Polarity : Horizontal

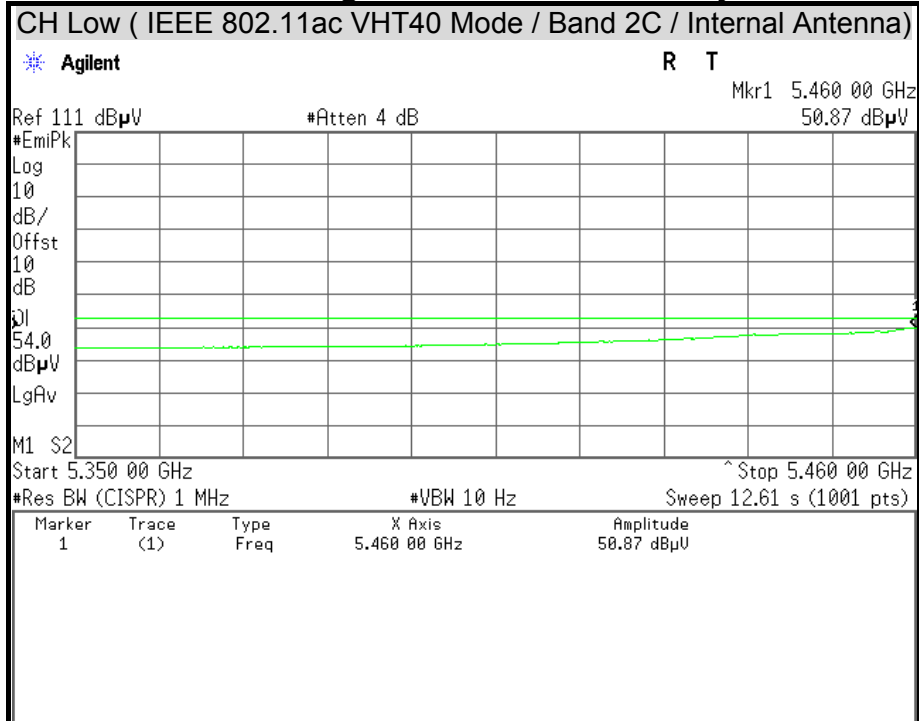



Detector Mode : Peak

Polarity : Vertical

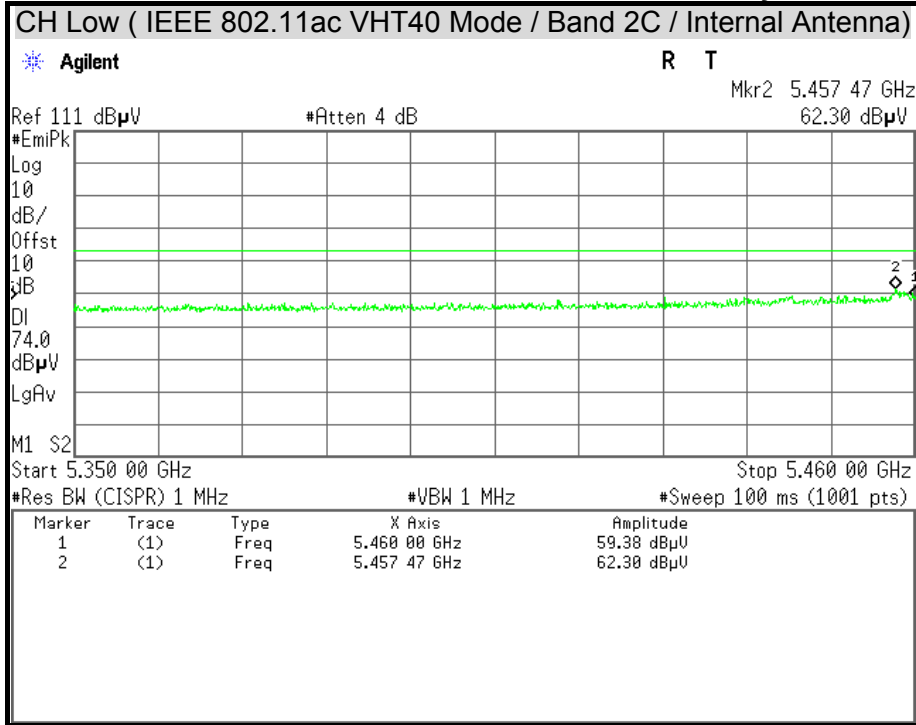

Detector Mode : Average

Polarity : Vertical

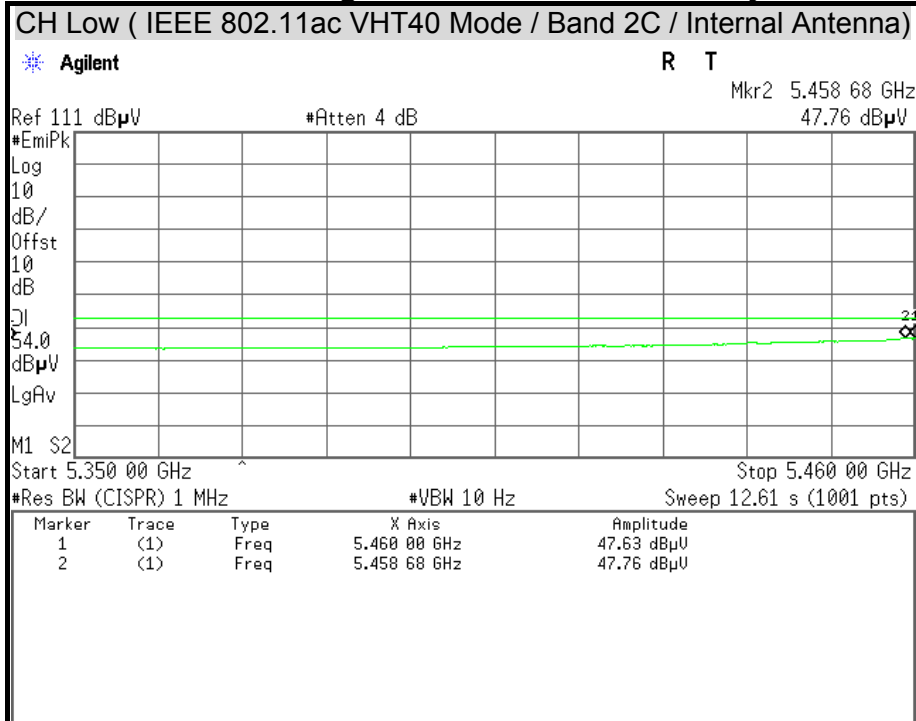



Detector Mode : Peak Polarity : Horizontal

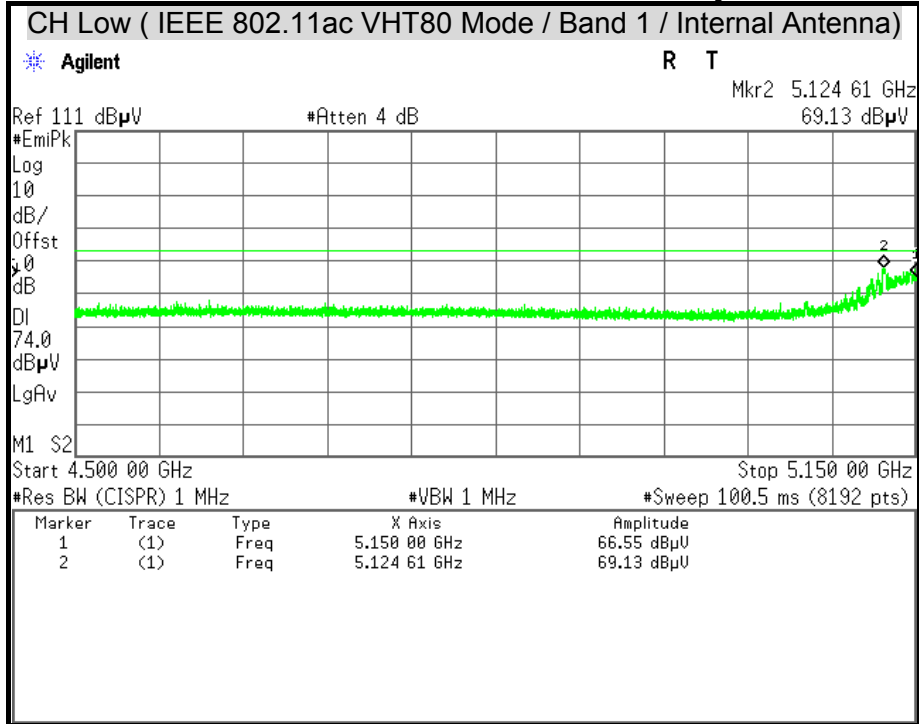

Detector Mode : Average Polarity : Horizontal

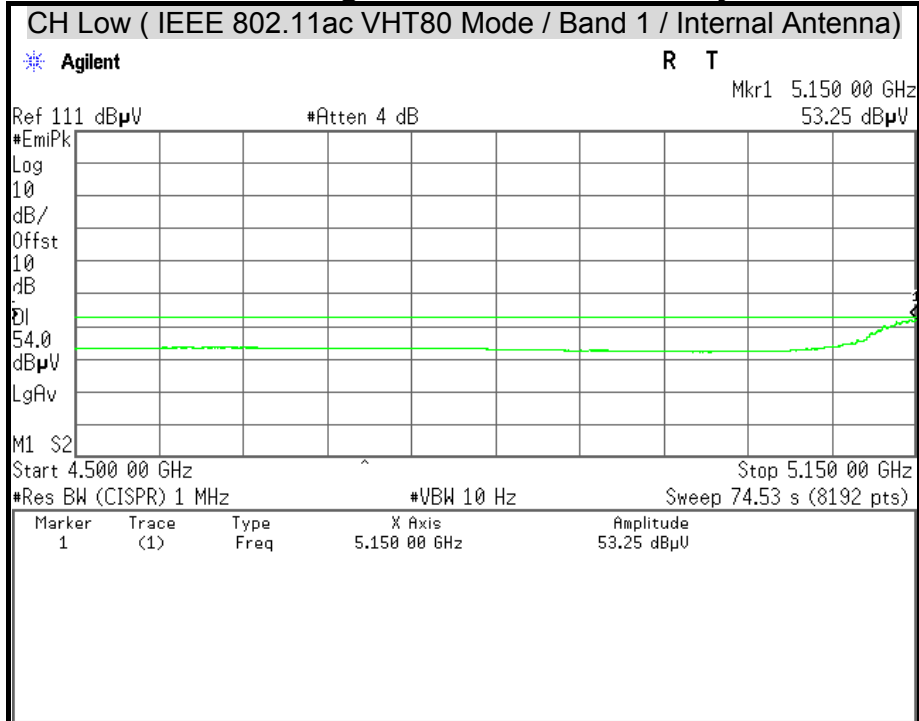



Detector Mode : Peak

Polarity : Vertical

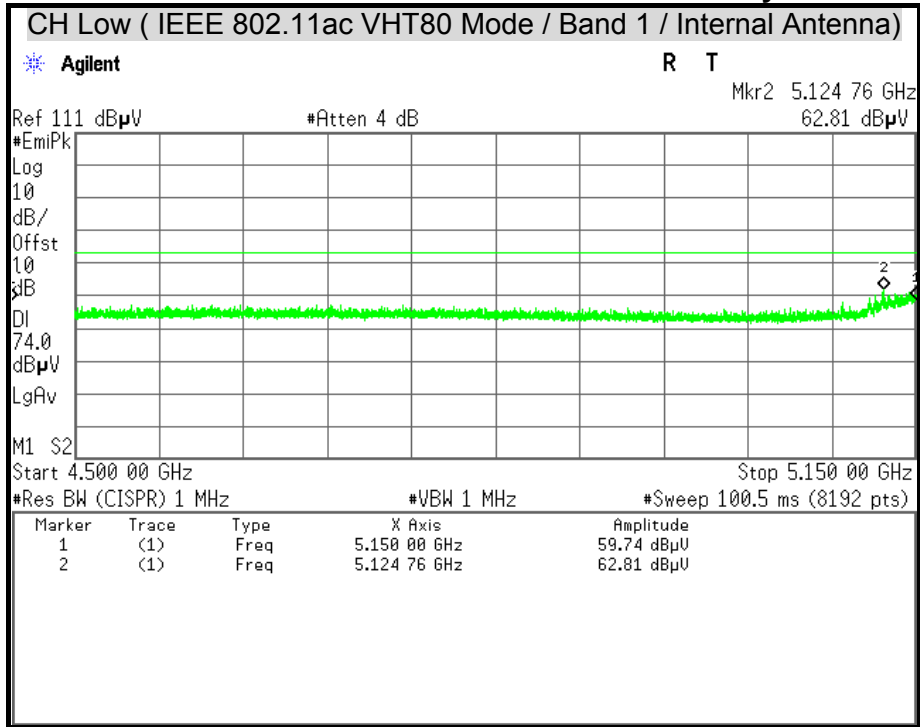

Detector Mode : Average

Polarity : Vertical

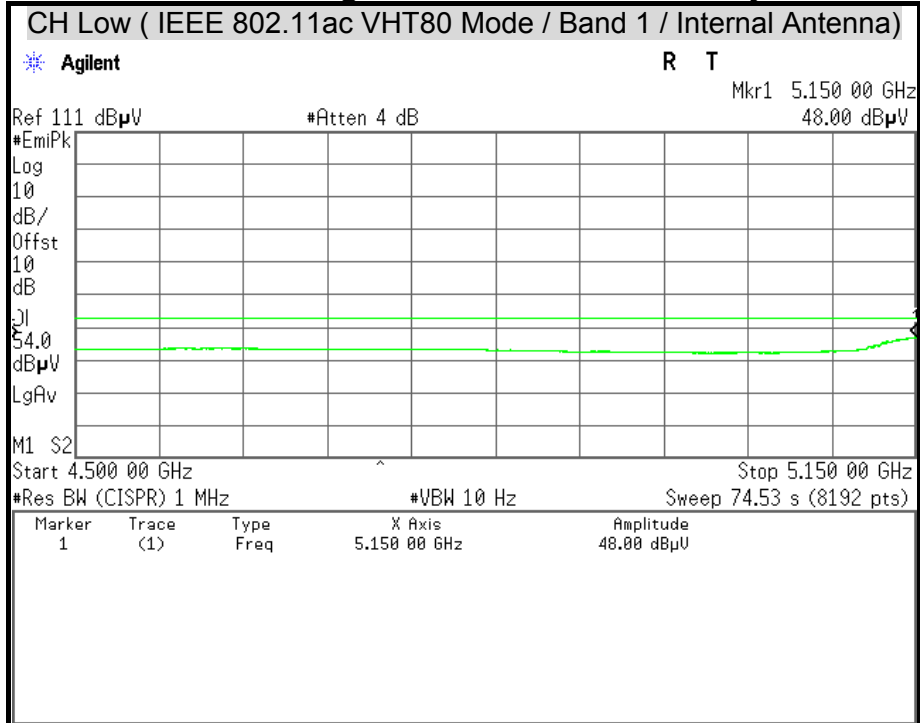



Detector Mode : Peak

Polarity : Horizontal

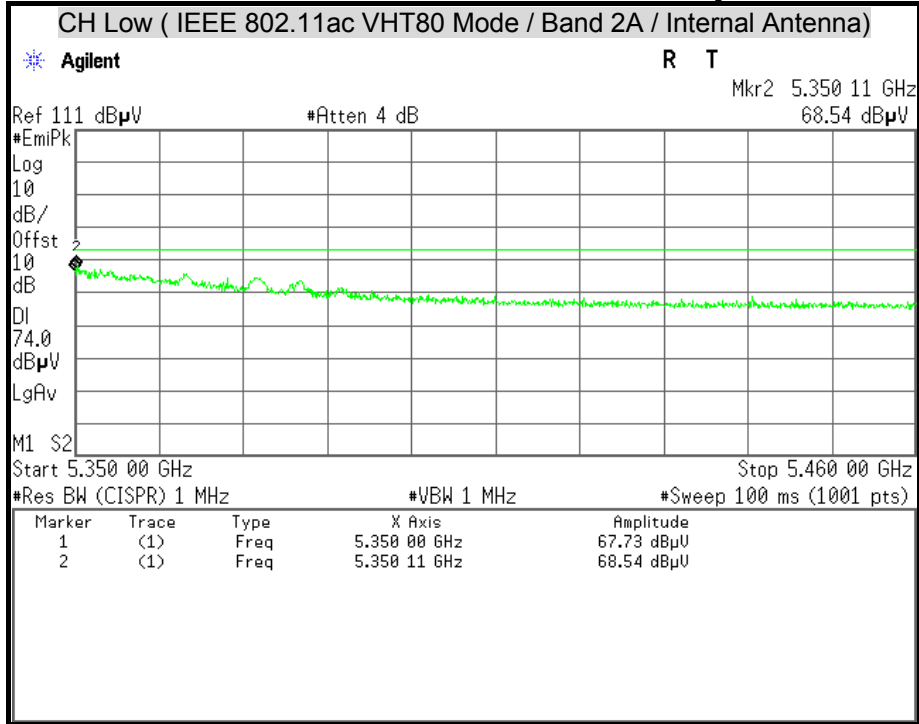

Detector Mode : Average

Polarity : Horizontal

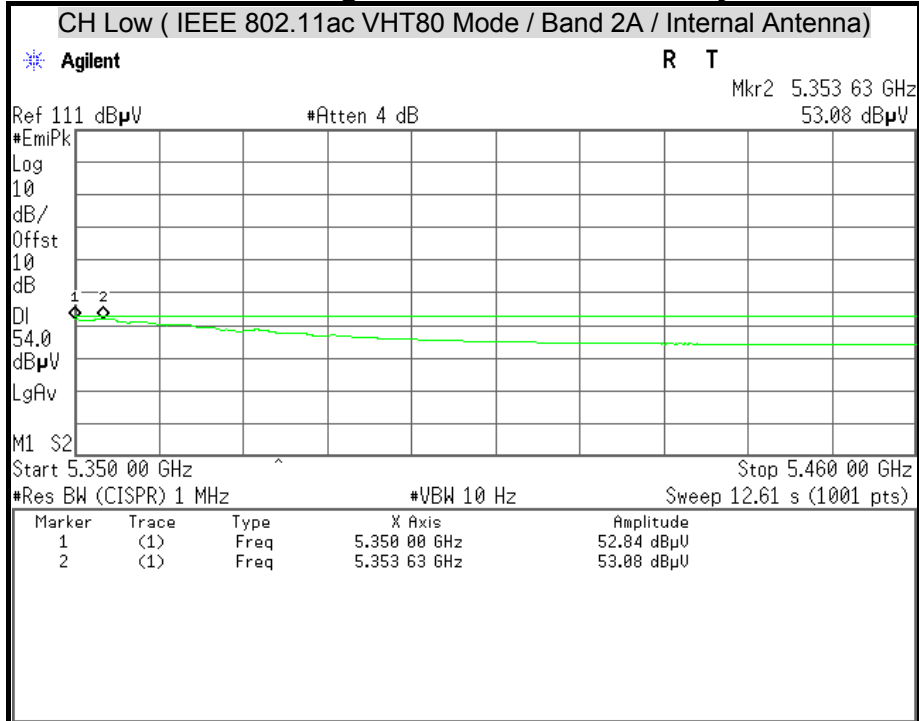



Detector Mode : Peak

Polarity : Vertical

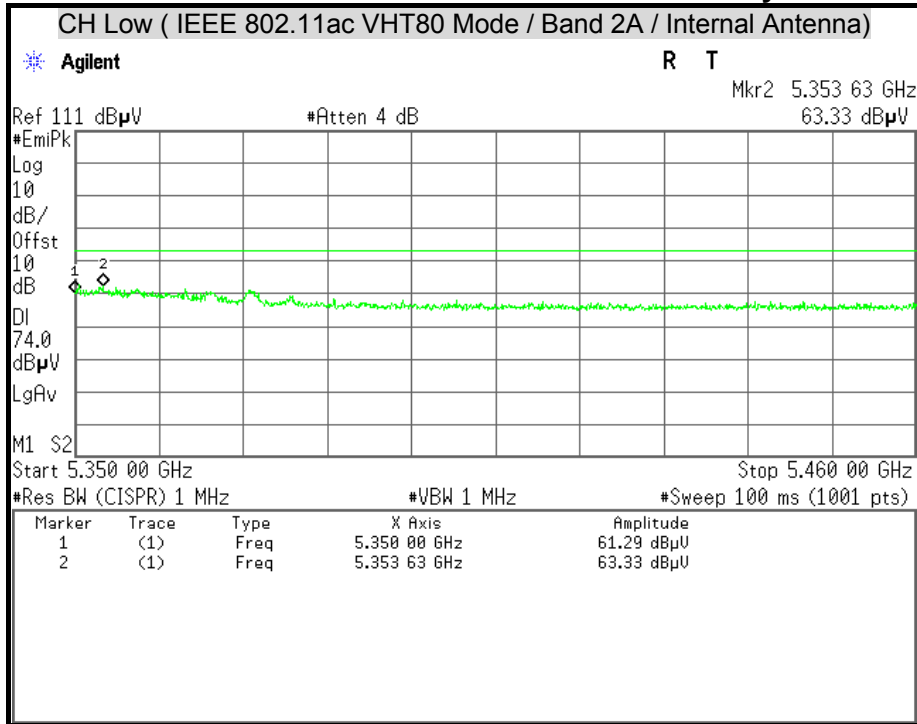

Detector Mode : Average

Polarity : Vertical

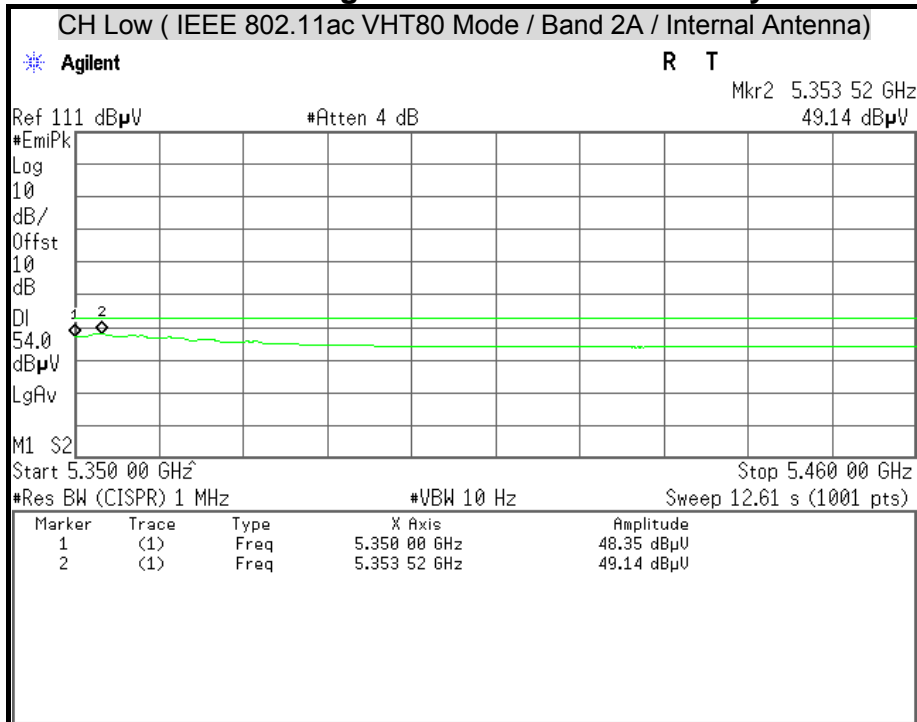



Detector Mode : Peak

Polarity : Horizontal

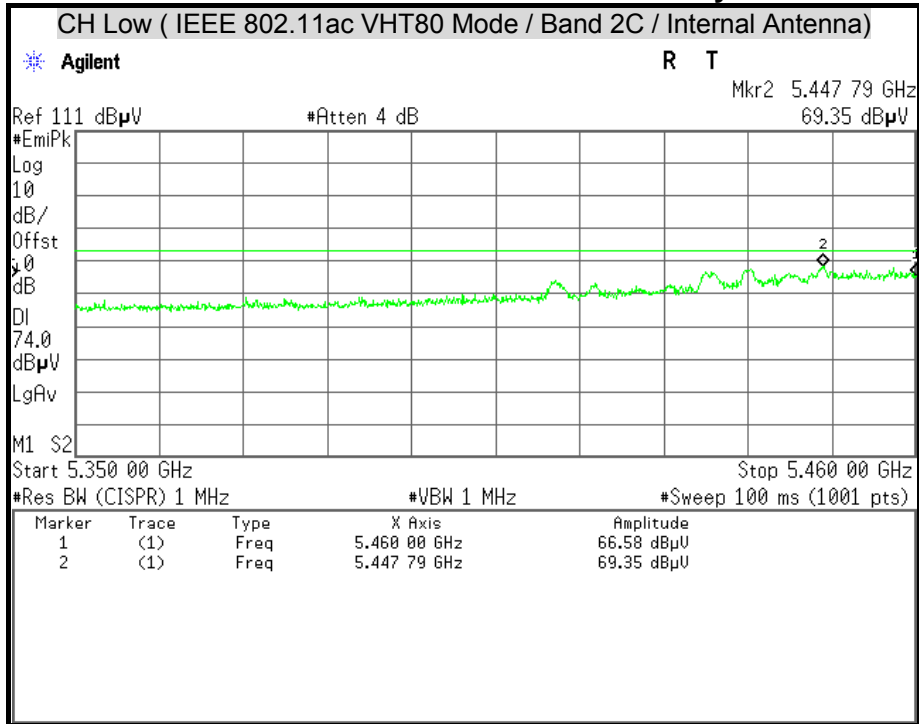

Detector Mode : Average

Polarity : Horizontal

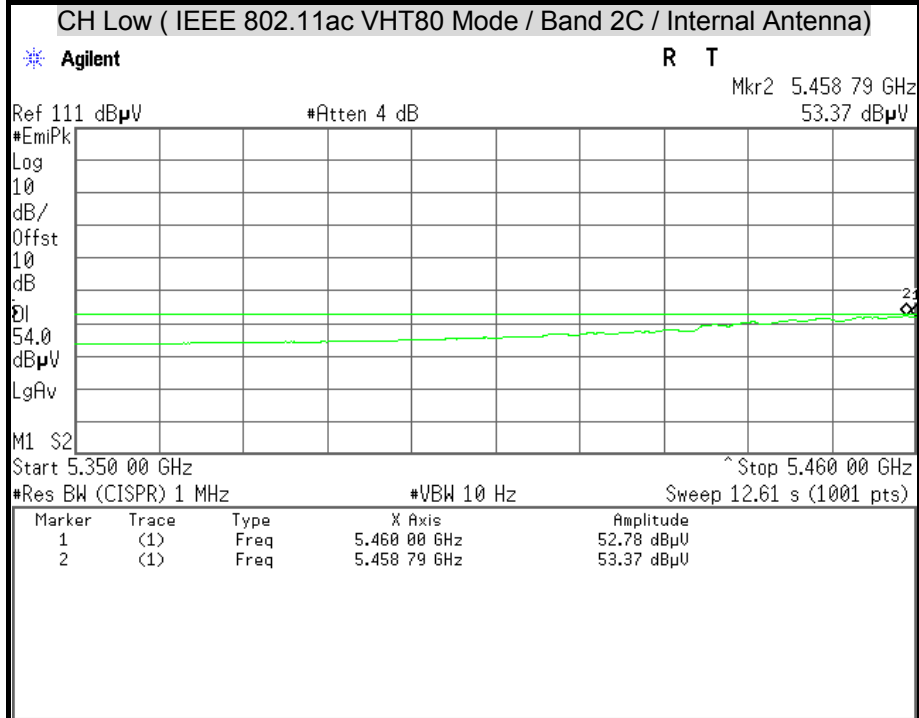



Detector Mode : Peak

Polarity : Vertical

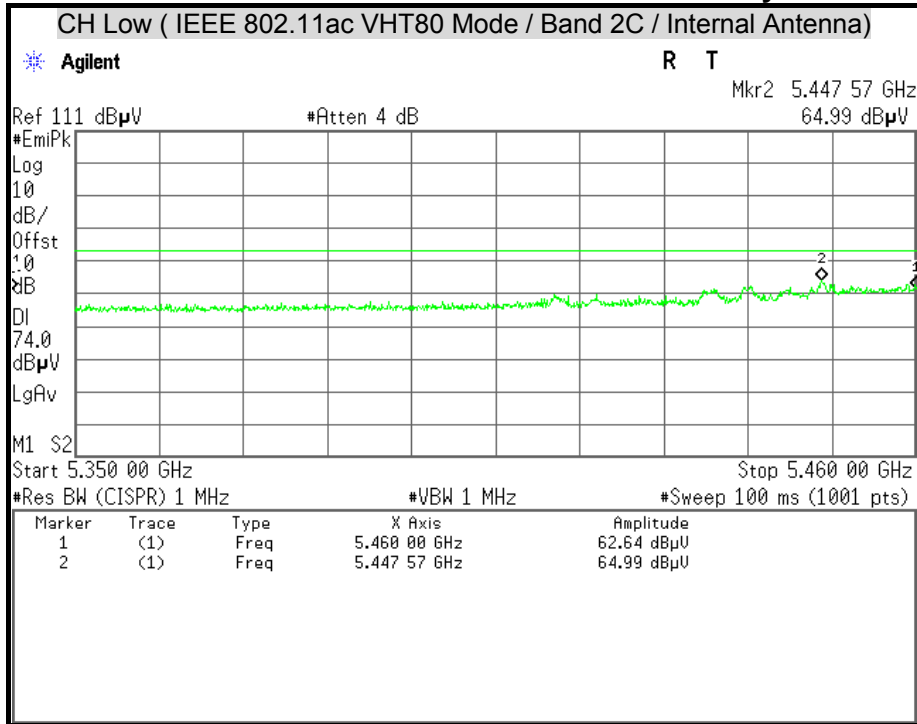

Detector Mode : Average

Polarity : Vertical

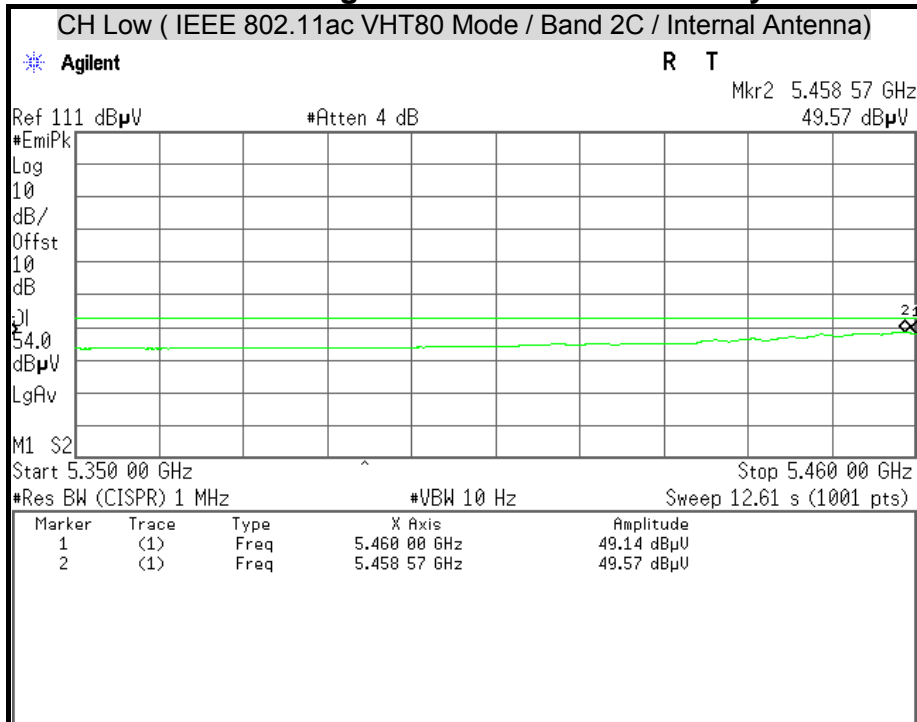



7.6 CONDUCTED EMISSION

LIMITS

§ 15.207 (a) Except as shown in paragraph (b) and (c) this section, for an intentional radiator that is designed to be connected to the public utility (AC) power line, the radio frequency voltage that is conducted back onto the AC power line on any frequency or frequencies within the band 150 kHz to 30 MHz shall not exceed the limits in the following table, as measured using a 50 μ H/50 ohms line impedance stabilization network (LISN). Compliance with the provisions of this paragraph shall be based on the measurement of the radio frequency voltage between each power line and ground at the power terminal. The lower limit applies at the boundary between the frequency ranges.

Frequency Range (MHz)	Conducted Limit (dB μ v)	
	Quasi-peak	Average
0.15 - 0.50	66 to 56	56 to 46
0.50 - 5.00	56	46
5.00 - 30.0	60	50

TEST EQUIPMENT

Name of Equipment	Manufacturer	Model	Serial Number	Calibration Due
L.I.S.N	SCHWARZBECK	NSLK 8127	8127-465	08/06/2015
L.I.S.N	SCHWARZBECK	NSLK 8127	8127-473	03/10/2015
EMI Receiver	ROHDE & SCHWARZ	ESCS 30	835418/008	11/02/2015
Pulse Limiter	ROHDE & SCHWARZ	ESH3-Z2	100111	06/30/2015

Remark: Each piece of equipment is scheduled for calibration once a year.



TEST SETUP

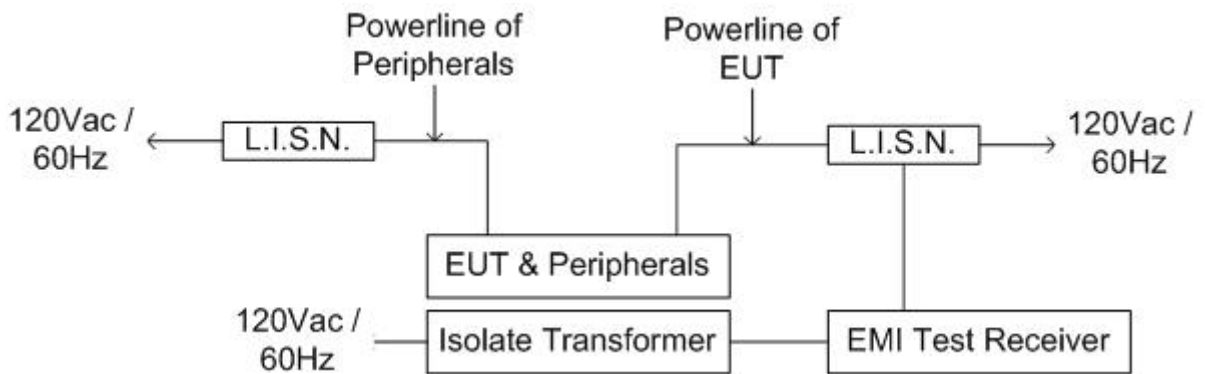
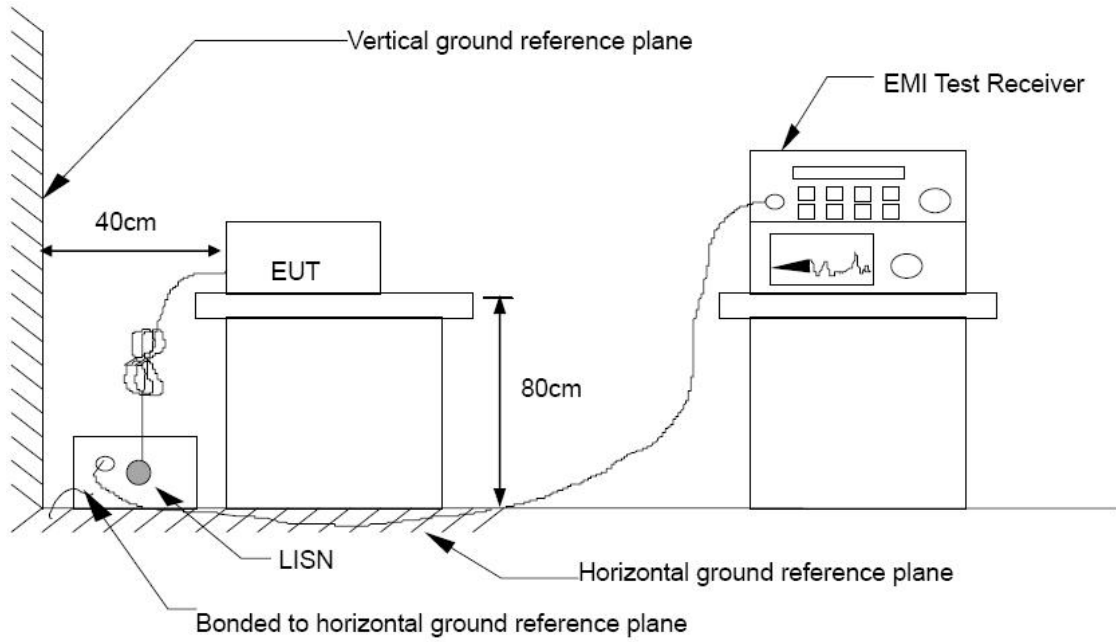



TEST PROCEDURE

The basic test procedure was in accordance with ANSI C63.10:2009.

The test procedure is performed in a 4m × 3m × 2.4m (L×W×H) shielded room.

The EUT along with its peripherals were placed on a 1.0m (W) × 1.5m (L) and 0.8m in height wooden table and the EUT was adjusted to maintain a 0.4 meter space from a vertical reference plane.

The EUT was connected to power mains through a line impedance stabilization network (LISN) which provides 50 ohm coupling impedance for measuring instrument and the chassis ground was bounded to the horizontal ground plane of shielded room. All peripherals were connected to the second LISN and the chassis ground also bounded to the horizontal ground plane of shielded room.

The EUT was located so that the distance between the boundary of the EUT and the closest surface of the LISN is 0.8 m. Where a mains flexible cord was provided by the manufacturer shall be 1 m long, or if in excess of 1 m, the excess cable was folded back and forth as far as possible so as to form a bundle not exceeding 0.4 m in length.

TEST RESULTS

Since the EUT is powered by DC Source, this test item is not applicable.



7.7 FREQUENCY STABILITY

LIMITS

§ 15.407 (g) manufacturers of U-NII devices are responsible for ensuring frequency stability such that an emission is maintained within the band of operation under all conditions of normal operation as specified in the user’s manual.

TEST EQUIPMENT

Name of Equipment	Manufacturer	Model	Serial Number	Calibration Due
Spectrum Analyzer	Agilent	E4446A	MY43360132	06/10/2015
Temp. & Humid. Chamber	TERCHY	MHC-120L	960424	09/09/2015

Remark: Each piece of equipment is scheduled for calibration once a year.

TEST SETUP

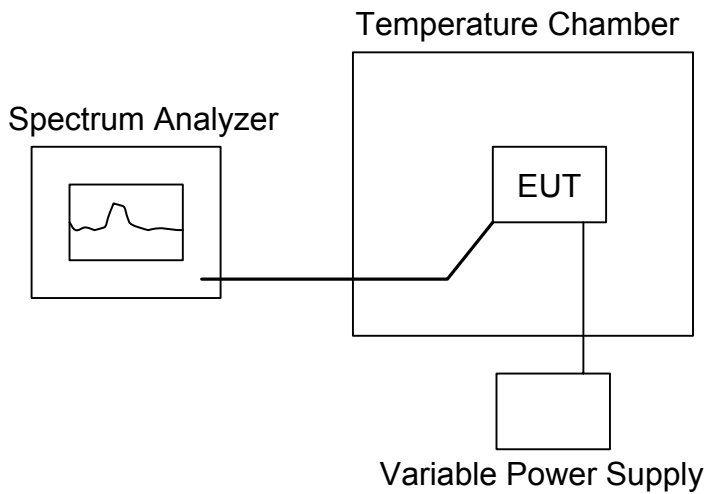



TEST PROCEDURE

1. Place the EUT on the table and set it in the transmitting mode.
2. Remove the antenna from the EUT and then connect a low loss RF cable from the antenna port to the spectrum analyzer.
3. Set the environment into appropriate environment.
4. Set the spectrum analyzer as RBW=1kHz, VBW = RBW, Span = 200kHz, Sweep = auto.
5. Mark the peak frequency and measure the frequency tolerance using frequency counter function.
6. Repeat until all the results are investigated.



TEST RESULTS

IEEE 802.11a mode

U-NII	Channel	Channel Frequency (MHz)	Measured Frequency (MHz)	Delta Frequency (kHz)	20 ppm Limit (kHz)	Margin (kHz)
Band 1	Low	5180	5179.997300	-2.70	103.60	-100.90
	Middle	5220	5220.001800	1.80	104.40	-102.60
	High	5240	5239.964800	-35.20	104.80	-69.60
Band 2A	Low	5260	5259.997300	-2.70	105.20	-102.50
	Middle	5280	5280.011200	11.20	105.60	-94.40
	High	5320	5319.957400	-42.60	106.40	-63.80
Band 2C	Low	5500	5499.998200	-1.80	110.00	-108.20
	Middle	5580	5579.990500	-9.50	111.60	-102.10
	High	5700	5700.000200	0.20	114.00	-113.80
Band 3	Low	5745	5744.967300	-32.70	114.90	-82.20
	Middle	5785	5785.012200	12.20	115.70	-103.50
	High	5825	5824.976200	-23.80	116.50	-92.70



IEEE 802.11ac VHT20 Mode

U-NII	Channel	Channel Frequency (MHz)	Measured Frequency (MHz)	Delta Frequency (kHz)	20 ppm Limit (kHz)	Margin (kHz)
Band 1	Low	5180	5179.996300	-3.70	103.60	-99.90
	Middle	5220	5220.001200	1.20	104.40	-103.20
	High	5240	5239.946500	-53.50	104.80	-51.30
Band 2A	Low	5260	5260.003200	3.20	105.20	-102.00
	Middle	5280	5280.012900	12.90	105.60	-92.70
	High	5320	5319.964800	-35.20	106.40	-71.20
Band 2C	Low	5500	5499.999600	-0.40	110.00	-109.60
	Middle	5580	5580.002300	2.30	111.60	-109.30
	High	5700	5700.012500	12.50	114.00	-101.50
Band 3	Low	5745	5745.000600	0.60	114.90	-114.30
	Middle	5785	5785.002000	2.00	115.70	-113.70
	High	5825	5824.945600	-54.40	116.50	-62.10



IEEE 802.11ac VHT40 Mode

U-NII	Channel	Channel Frequency (MHz)	Measured Frequency (MHz)	Delta Frequency (kHz)	20 ppm Limit (kHz)	Margin (kHz)
Band 1	Low	5190	5190.062400	62.40	103.80	-41.40
	High	5230	5230.016900	16.90	104.60	-87.70
Band 2A	Low	5270	5269.975600	-24.40	105.40	-81.00
	High	5310	5310.012500	12.50	106.20	-93.70
Band 2C	Low	5510	5509.995200	-4.80	110.20	-105.40
	Middle	5550	5549.967300	-32.70	111.00	-78.30
	High	5670	5670.001800	1.80	113.40	-111.60
Band 3	Low	5755	5755.019200	19.20	115.10	-95.90
	High	5795	5795.008100	8.10	115.90	-107.80



IEEE 802.11ac VHT80 Mode

U-NII	Channel	Channel Frequency (MHz)	Measured Frequency (MHz)	Delta Frequency (kHz)	20 ppm Limit (kHz)	Margin (kHz)
Band 1	Low	5210	5210.062400	62.40	104.20	-41.80
Band 2A	Low	5290	5290.016900	16.90	105.80	-88.90
Band 2C	Low	5530	5529.975600	-24.40	110.60	-86.20
Band 3	Low	5775	5775.012500	12.50	115.50	-103.00