

FCC Test Report

Product Name	TABLET PC
Model No.	PM-521
FCC ID	2ABTU-PM-521

Applicant	RuggON Corporation
Address	3F., No.10, Ln. 181, Sec. 2, Jiuzong Rd., Neihu Dist., Taipei City, Taiwan

Date of Receipt	Jan. 06, 2015
Issued Date	Feb. 16, 2015
Report No.	1510151R-RFUSP17V00
Report Version	V1.0



The test results relate only to the samples tested.

The test results shown in the test report are traceable to the national/international standard through the calibration report of the equipment and evaluated measurement uncertainty herein.

This report must not be used to claim product endorsement by TAF or any agency of the government.

The test report shall not be reproduced without the written approval of QuieTek Corporation.

Test Report

Issued Date: Feb. 16, 2015

Report No.: 1510151R-RFUSP17V00

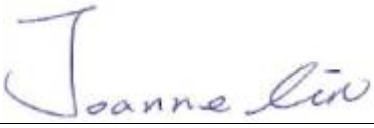

Product Name	TABLET PC
Applicant	RuggON Corporation
Address	3F., No.10, Ln. 181, Sec. 2, Jiuzong Rd., Neihu Dist., Taipei City, Taiwan
Manufacturer	Ubiquonn Technology, Inc.
Model No.	PM-521
FCC ID.	2ABTU-PM-521
EUT Rated Voltage	AC 100-240V, 50-60Hz
EUT Test Voltage	AC 120V/60Hz
Trade Name	RuggON
Applicable Standard	FCC CFR Title 47 Part 15 Subpart C: 2014 ANSI C63.4: 2014, ANSI C63.10: 2013
Test Result	Complied

Documented By : 
 (Senior Adm. Specialist / Joanne Lin)

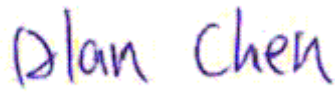
Tested By : 
 (Engineer / Alan Chen)

Approved By : 
 (Director / Vincent Lin)

TABLE OF CONTENTS

Description	Page
1. GENERAL INFORMATION	4
1.1. EUT Description.....	4
1.2. Operational Description	5
1.3. Tested System Details.....	6
1.4. Configuration of tested System	6
1.5. EUT Exercise Software	7
1.6. Test Facility	7
2. Conducted Emission.....	9
2.1. Test Equipment.....	9
2.2. Test Setup	9
2.3. Limits	10
2.4. Test Procedure	10
2.5. Uncertainty	10
2.6. Test Result of Conducted Emission.....	11
3. Radiated Emission.....	13
3.1. Test Equipment.....	13
3.2. Test Setup	13
3.3. Limits	14
3.4. Test Procedure	15
3.5. Uncertainty	16
3.6. Test Result of Radiated Emission.....	17
4. Band Edge	20
4.1. Test Equipment.....	20
4.2. Test Setup	20
4.3. Limits	21
4.4. Test Procedure	21
4.5. Uncertainty	21
4.6. Test Result of Band Edge	22
5. Frequency Tolerance	23
5.1. Test Equipment.....	23
5.2. Test Setup	23
5.3. Limits	23
5.4. Test Procedure	23
5.5. Uncertainty	23
5.6. Test Result of Frequency Stability.....	24
6. EMI Reduction Method During Compliance Testing	26
Attachment 1: EUT Test Photographs	
Attachment 2: EUT Detailed Photographs	

1. GENERAL INFORMATION

1.1. EUT Description

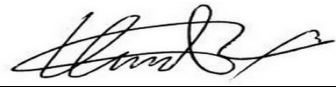
Product Name	TABLET PC
Trade Name	RuggON
Model No.	PM-521
FCC ID	2ABTU-PM-521
Frequency Range	13.56MHz
Modulation	ASK
Antenna Type	Loop antenna
Power Adapter	MFR: FSP, M/N: FSP065-REB Input: AC 100-240V~1.5A, 50-60Hz Output: 19V $\overline{=}$ 3.42A Cable Out: Shielded, 1.5m, with one ferrite core bonded.
Contain Module	Intel / 7260HMW

Frequency of Each Channel:

Channel	Frequency
Channel 1:	13.56 MHz

Note:

1. This device is a TABLET PC with a built-in 13.56MHz transceiver.
2. These tests were conducted on a sample of the equipment for the purpose of demonstrating compliance with Part 15 Subpart C Paragraph 15.225
3. The radiation measurements are performed in X, Y, Z axis positioning. Only the worst case is shown in the report.

Test Mode	Mode 1: Transmit mode
-----------	-----------------------

1.3. Tested System Details

The types for all equipment, plus descriptions of all cables used in the tested system (including inserted cards) are:

Product	Manufacturer	Model No.	Serial No.	Power Cord
1 Monitor	DELL	ST2320L	N/A	Non-Shielded, 1.8m
2 Earphone	AIWA	N/A	N/A	N/A
3 IPod nano	Apple	A1199	YM708A72VQ5	N/A
4 Modem	ACEEX	DM-1414	0102027553	N/A
5 USB Dongle	Transcend	JF V30	N/A	Non-Shielded, 1.8m

Signal Cable Type	Signal cable Description
A HDMI Cable	Shielded, 1.8m
B Earphone Cable	Shielded, 1.8m
C IPod Cable	Shielded, 1.2m
D RS-232 Cable	Shielded, 1.8m
E RJ45 Cable	Shielded, 2.0m

1.4. Configuration of tested System

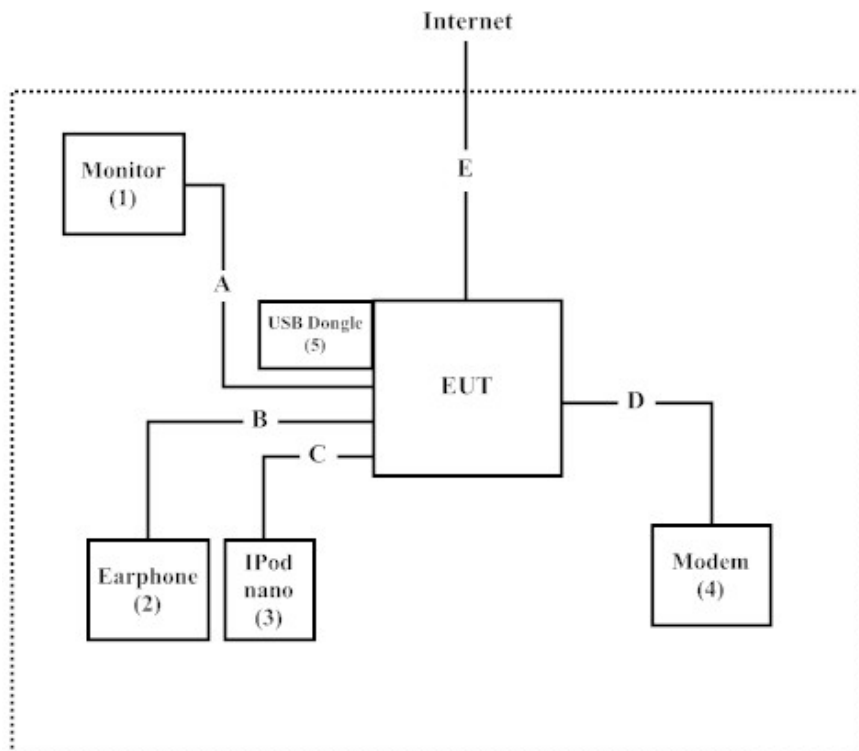

1.5. EUT Exercise Software

- (1) Setup the EUT as shown in Section 1.4
- (2) Execute software “DRTU-v1.7.3.859” on the Notebook PC.
- (3) Configure the test mode, the test channel, and the data rate.
- (4) Press “OK” to start the continuous Transmit.
- (5) Verify that the EUT works properly.

1.6. Test Facility

Ambient conditions in the laboratory:

Items	Required (IEC 68-1)	Actual
Temperature (°C)	15-35	20-35
Humidity (%RH)	25-75	50-65
Barometric pressure (mbar)	860-1060	950-1000

The related certificate for our laboratories about the test site and management system can be downloaded from QuieTek Corporation's Web Site: <http://www.quietek.com/tw/ctg/cts/accreditations.htm>

The address and introduction of QuieTek Corporation's laboratories can be founded in our Web site: <http://www.quietek.com/>

Site Description: File on
Federal Communications Commission
FCC Engineering Laboratory
7435 Oakland Mills Road
Columbia, MD 21046
Registration Number: 92195

Site Name: Quietek Corporation
Site Address: No.5-22, Ruishukeng,
Linkou Dist. New Taipei City 24451,
Taiwan, R.O.C.
TEL: 886-2-8601-3788 / FAX : 886-2-8601-3789
E-Mail : service@quietek.com

FCC Accreditation Number: TW1014

2. Conducted Emission

2.1. Test Equipment

	Equipment	Manufacturer	Model No. / Serial No.	Last Cal.	Remark
X	Test Receiver	R & S	ESCS 30 / 825442/018	Sep., 2014	
X	Artificial Mains Network	R & S	ENV4200 / 848411/10	Feb., 2015	Peripherals
X	LISN	R & S	ESH3-Z5 / 825562/002	Feb., 2015	EUT
	DC LISN	Schwarzbeck	8226 / 176	Mar., 2014	EUT
X	Pulse Limiter	R & S	ESH3-Z2 / 357.8810.52	Feb., 2015	
	No.1 Shielded Room				

Note:

1. All equipments are calibrated every one year.
2. The test instruments marked by “X” are used to measure the final test results.

2.2. Test Setup

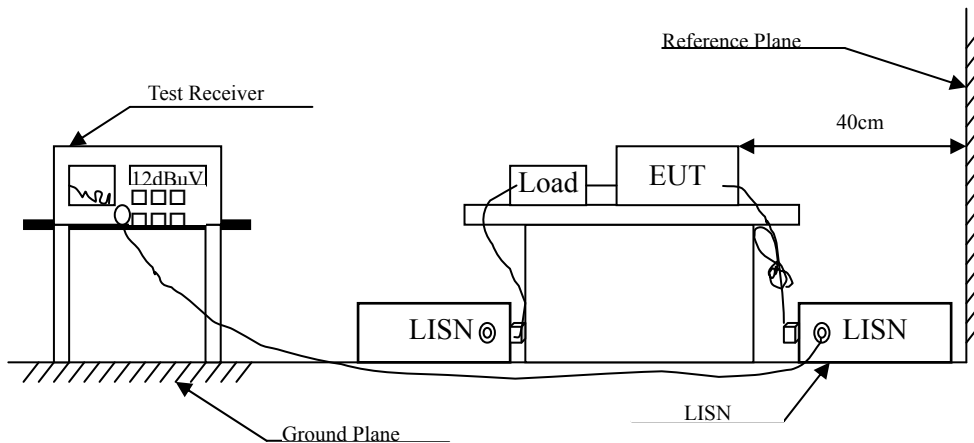

2.3. Limits

FCC Part 15 Subpart C Paragraph 15.207 (dBμV) Limit		
Frequency MHz	Limits	
	QP	AV
0.15 - 0.50	66-56 _(註)	56-46 _(註)
0.50-5.0	56	46
5.0 - 30	60	50

2.4. Test Procedure

The EUT and simulators are connected to the main power through a line impedance stabilization network (L.I.S.N.). This provides a 50 ohm /50uH coupling impedance for the measuring equipment. The peripheral devices are also connected to the main power through a LISN that provides a 50ohm /50uH coupling impedance with 50ohm termination. (Please refers to the block diagram of the test setup and photographs.)

Both sides of A.C. line are checked for maximum conducted interference. In order to find the maximum emission, the relative positions of equipment and all of the interface cables must be changed according to ANSI C63.10: 2013 on conducted measurement.

Conducted emissions were invested over the frequency range from 0.15MHz to 30MHz using a receiver bandwidth of 9kHz.

2.5. Uncertainty

± 2.26 dB

2.6. Test Result of Conducted Emission

Product : TABLET PC
 Test Item : Conducted Emission Test
 Power Line : Line 1
 Test Mode : Mode 1: Transmit mode

Frequency MHz	Correct Factor dB	Reading Level dBμV	Measurement Level dBμV	Margin dB	Limit dBμV
LINE 1					
Quasi-Peak					
0.170	9.743	34.220	43.964	-21.465	65.429
0.216	9.739	30.030	39.769	-24.345	64.114
0.334	9.745	27.380	37.125	-23.618	60.743
0.490	9.752	32.180	41.932	-14.354	56.286
0.779	9.765	28.600	38.365	-17.635	56.000
7.920	9.910	27.320	37.230	-22.770	60.000
Average					
0.170	9.743	18.800	28.544	-26.885	55.429
0.216	9.739	22.700	32.439	-21.675	54.114
0.334	9.745	24.340	34.085	-16.658	50.743
0.490	9.752	24.580	34.332	-11.954	46.286
0.779	9.765	20.320	30.085	-15.915	46.000
7.920	9.910	21.530	31.440	-18.560	50.000

Note:

1. All Reading Levels are Quasi-Peak and average value.
2. “” means the worst emission level.
3. Measurement Level = Reading Level + Correct Factor

Product : TABLET PC
 Test Item : Conducted Emission Test
 Power Line : Line 2
 Test Mode : Mode 1: Transmit mode

Frequency MHz	Correct Factor dB	Reading Level dBμV	Measurement Level dBμV	Margin dB	Limit dBμV
LINE 2					
Quasi-Peak					
0.173	9.747	31.650	41.397	-23.946	65.343
0.509	9.753	33.100	42.853	-13.147	56.000
0.771	9.775	28.660	38.435	-17.565	56.000
1.974	9.839	19.840	29.679	-26.321	56.000
6.685	9.900	23.990	33.890	-26.110	60.000
20.920	10.100	24.460	34.560	-25.440	60.000
Average					
0.173	9.747	12.100	21.847	-33.496	55.343
0.509	9.753	21.120	30.873	-15.127	46.000
0.771	9.775	18.660	28.435	-17.565	46.000
1.974	9.839	6.030	15.869	-30.131	46.000
6.685	9.900	16.290	26.190	-23.810	50.000
20.920	10.100	19.050	29.150	-20.850	50.000

Note:

1. All Reading Levels are Quasi-Peak and average value.
2. “ ” means the worst emission level.
3. Measurement Level = Reading Level + Correct Factor

3. Radiated Emission

3.1. Test Equipment

The following test equipments are used during the radiated emission test:

Test Site	Equipment	Manufacturer	Model No./Serial No.	Last Cal.
Site # 3	X Magnetic Loop Antenna	Teseq	HLA6121/ 37133	Sep., 2014
	X Bilog Antenna	Schaffner Chase	CBL6112B/ 2707	Jun., 2014
	X EMI Test Receiver	R&S	ESCS 30/838251/ 001	Jun., 2014
	X Coaxial Cable	QTK(Arnist)	RG 214/ LC003-RG	Jun., 2014
	X Coaxial signal switch	Arnist	MP59B/ 6200798682	Jun., 2014

3.2. Test Setup

9kHz~30MHz

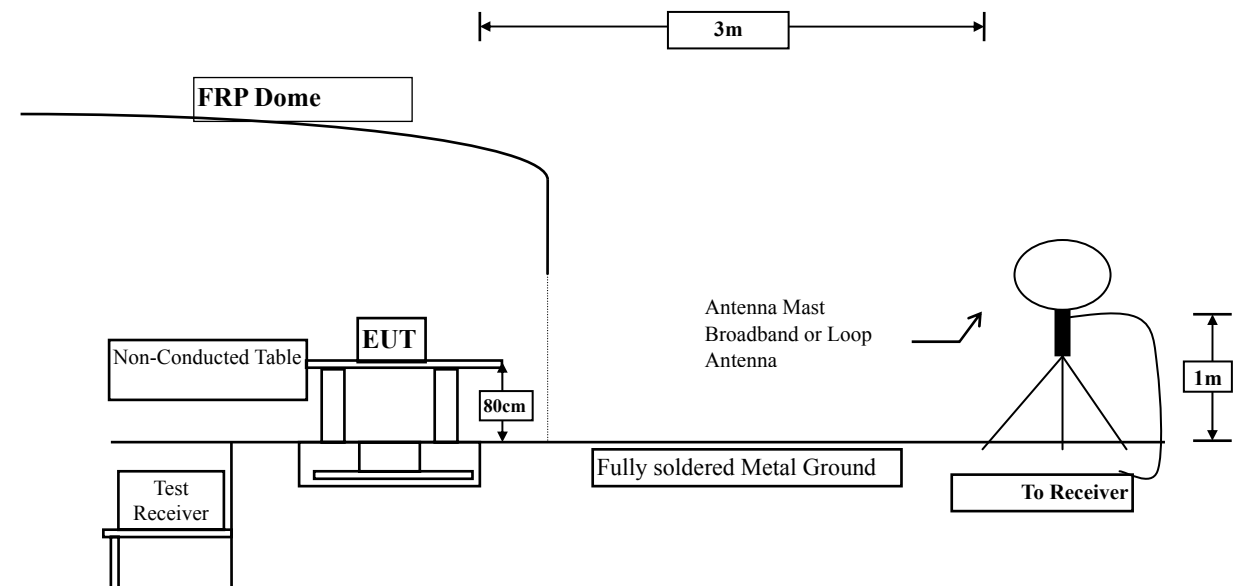

30MHz~1GHz

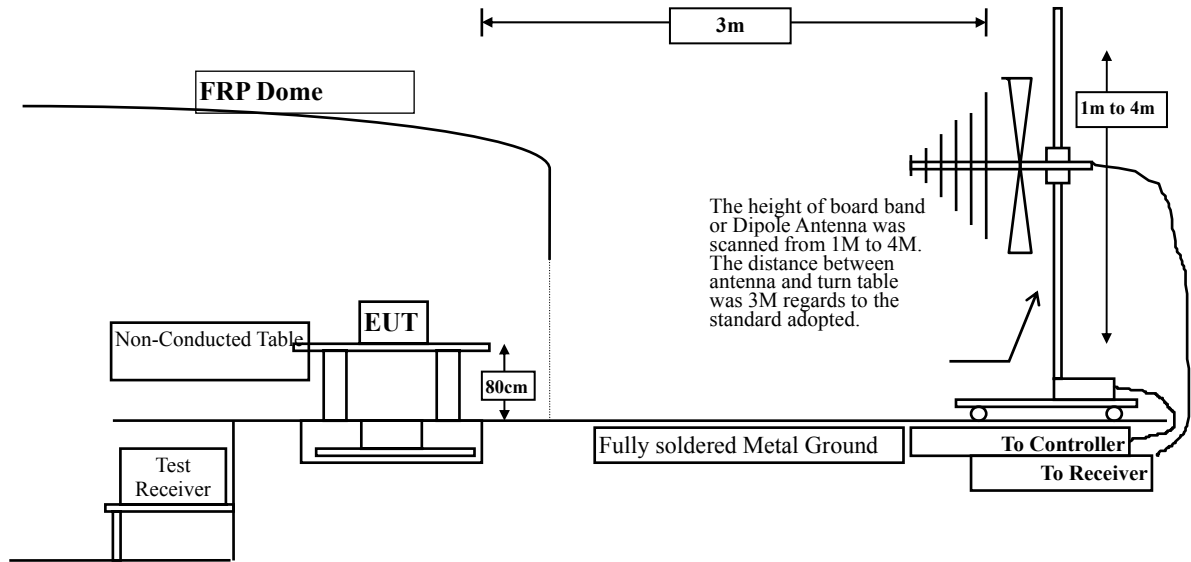

3.3. Limits

➤ Fundamental electric field strength Limit

FCC Part 15 Subpart C Paragraph 15.225 Limits				
Fundamental Frequency MHz	Field strength of fundamental			
	uV/m	Distance (meter)	dBμV/m	Distance (meter)
13.553 – 13.567	15848	30	124	3
13.410 – 13.553 and 13.567 – 13.710	334	30	90.47	3
13.110 – 13.410 and 13.710 – 14.010	106	30	80.50	3
Outside of the 13.110 – 14.010	See 15.209 Limits			

- Remarks :
1. RF Voltage (dBμV) = 20 log RF Voltage (uV)
 2. Distance refers to the distance in meters between the measuring instrument antenna and the closed point of any part of the device or system.
 3. The emission limit in this paragraph is based on measurement instrumentation employing an average detector.

► Spurious electric field strength Limit

FCC Part 15 Subpart C Paragraph 15.209 Limits			
Frequency MHz	uV/m	dBµV/m	Measurement distance (meter)
0.009-0.490	2400/F(kHz)	See Remark ¹	300
0.490-1.705	24000/F(kHz)	See Remark ¹	30
1.705-30	30	29.5	30
30-88	100	40	3
88-216	150	43.5	3
216-960	200	46	3
Above 960	500	54	3

- Remarks :
1. RF Voltage (dBµV) = 20 log RF Voltage (uV)
 2. In the Above Table, the tighter limit applies at the band edges.
 3. Distance refers to the distance in meters between the measuring instrument antenna and the closed point of any part of the device or system.

3.4. Test Procedure

Fundamental electric field strength:

The EUT and its simulators are placed on a turn table which is 1 meter above ground. The turn table can rotate 360 degrees to determine the position of the maximum electric field strength. The EUT was positioned such that the distance from antenna to the EUT was 3 meters. The antenna which is 1 meter above ground. All X-axis, Y-axis and Z-axis polarization of the antenna are set on measurement.

Spurious electric field strength:

The EUT and its simulators are placed on a turn table which is 0.8 meter above ground. The turn table can rotate 360 degrees to determine the position of the maximum emission level. The antenna can move up and down between 1 meter and 4 meters to find out the maximum emission level. The EUT was positioned such that the distance from antenna to the EUT was 3 meters. Both horizontal and vertical polarization of the antenna are set on measurement. In order to find the maximum emission, all of the interface cables must be manipulated according to ANSI C63.10: 2013 on radiated measurement.

On any frequency the radiated limits shown are based upon the use of measurement instrumentation employing an average detector function. When average radiated emission measurement are included emission measurement below 1000 MHz, there also is a limit on the radio frequency emissions, as measured using instrumentation with a peak detector function, corresponding to 20 dB above the maximum permitted average limit.

The bandwidth below 30MHz setting on the field strength meter is 9kHz and above 30MHz is 120kHz.

The frequency range from 9kHz to 10th harmonics is checked.

3.5. Uncertainty

± 2.6 dB below 30MHz

± 3.8 dB above 30MHz

3.6. Test Result of Radiated Emission

Product : TABLET PC
 Test Item : Fundamental Radiated Emission
 Test Site : No.3 OATS
 Test Mode : Mode 1: Transmit mode

Frequency MHz	Correct Factor dB	Reading Level dBμV	Measurement Level dBμV/m	Margin dB	Limit dBμV/m
X-axis					
Quasi-Peak					
Horizontal					
13.560	20.410	37.150	57.560	-66.440	124.000
Vertical					
13.560	20.410	39.630	60.040	-63.960	124.000
Y-axis					
Quasi-Peak					
Horizontal					
13.560	20.410	41.120	61.530	-62.470	124.000
Vertical					
13.560	20.410	38.130	58.540	-65.460	124.000
Z-axis					
Quasi-Peak					
Horizontal					
13.560	20.410	40.130	60.540	-63.460	124.000
Vertical					
13.560	20.410	39.960	60.370	-63.630	124.000

Note:

1. Limit=84dB μ V/m + 40*Log (30(m)/3(m))=124dB μ V/m
2. All Readings below 1GHz are Quasi-Peak, above are average value.
3. Measurement Level = Reading Level + Correct Factor.
4. The average measurement was not performed when the peak measured data under the limit of average detection. If the readings given are average, peak measurement should also be supplied.

Product : TABLET PC
 Test Item : General Radiated Emission Data (below 30MHz)
 Test Site : No.3 OATS
 Test Mode : Mode 1: Transmit mode

Frequency	Correct	Reading	Measurement	Margin	Limit
MHz	Factor	Level	Level	dB	dB μ V/m
	dB	dB μ V	dB μ V/m		
Horizontal					
27.120	19.950	25.220	45.170	-24.370	69.540
Vertical					
27.120	19.950	24.950	44.900	-24.640	69.540

Note:

1. Limit=29.54dB μ V/m + 40*Log (30(m)/3(m))=69.54dB μ V/m
2. All Readings below 1GHz are Quasi-Peak, above are average value.
3. "█" means the worst emission level.
4. Measurement Level = Reading Level + Correct Factor.

Product : TABLET PC
 Test Item : General Radiated Emission Data (above 30MHz)
 Test Site : No.3 OATS
 Test Mode : Mode 1: Transmit mode

Frequency MHz	Correct Factor dB	Reading Level dBμV	Measurement Level dBμV/m	Margin dB	Limit dBμV/m
Horizontal					
QP Detector					
107.600	-7.597	34.490	26.893	-16.607	43.500
225.940	-9.647	44.883	35.236	-10.764	46.000
365.620	0.382	33.763	34.145	-11.855	46.000
600.360	3.472	26.384	29.856	-16.144	46.000
800.180	6.417	24.940	31.357	-14.643	46.000
951.500	6.993	24.981	31.974	-14.026	46.000
Vertical					
QP Detector					
43.580	-10.919	41.976	31.057	-8.943	40.000
262.800	-4.944	33.778	28.834	-17.166	46.000
511.120	0.783	23.826	24.609	-21.391	46.000
689.600	2.302	22.662	24.964	-21.036	46.000
817.640	2.966	23.702	26.668	-19.332	46.000
920.460	3.272	23.924	27.196	-18.804	46.000

Note:

1. All Readings below 1GHz are Quasi-Peak, above are average value.
2. "█" means the worst emission level.
3. Measurement Level = Reading Level + Correct Factor

4. Band Edge

4.1. Test Equipment

Test Site	Equipment	Manufacturer	Model No./Serial No.	Last Cal.
☒ Site # 3	X Magnetic Loop Antenna	Teseq	HLA6121/ 37133	Sep., 2014
	X Bilog Antenna	Schaffner Chase	CBL6112B/ 2707	Jun., 2014
	X EMI Test Receiver	R&S	ESCS 30/838251/ 001	Jun., 2014
	X Coaxial Cable	QTK(Arnist)	RG 214/ LC003-RG	Jun., 2014
	X Coaxial signal switch	Arnist	MP59B/ 6200798682	Jun., 2014

Note: 1. All equipments are calibrated with traceable calibrations. Each calibration is traceable to the national or international standards.
 2. The test instruments marked with “X” are used to measure the final test results.

4.2. Test Setup

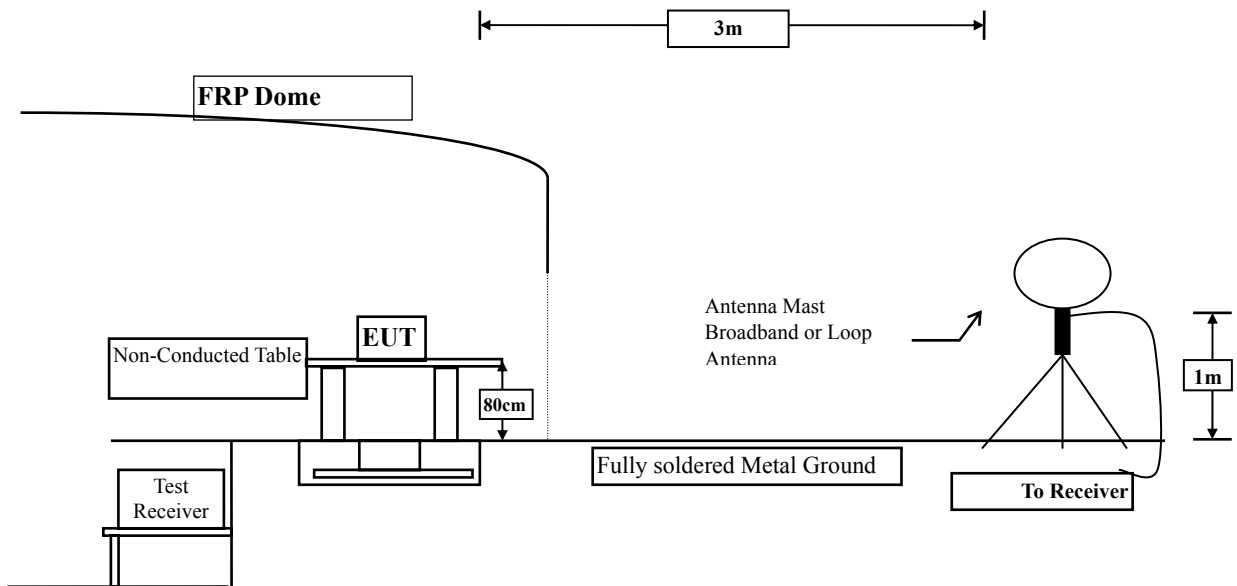

4.3. Limits

In any 9 kHz bandwidth outside the frequency band in which the spread spectrum intentional radiator is operating, the radio frequency power that is produced by the intentional radiator shall be at least 50 dB below that in the 9 kHz bandwidth within the band that contains the highest level of the desired power, based on either an RF conducted or a radiated measurement. Attenuation below the general limits specified in Section 15.209(a) is not required. In addition, radiated emissions which fall in the restricted bands, as defined in Section 15.205(a), must also comply with the radiated emission limits specified in Section 15.209(a) (see Section 15.205(c)).

4.4. Test Procedure

The EUT and its simulators are placed on a turn table which is 0.8 meter above ground. The turn table can rotate 360 degrees to determine the position of the maximum emission level. The EUT was positioned such that the distance from antenna to the EUT was 3 meters.

The antenna can move up and down between 1 meter and 4 meters to find out the maximum emission level.

Both horizontal and vertical polarization of the antenna are set on measurement. In order to find the maximum emission, all of the interface cables must be manipulated according to ANSI C63.10: 2013 on radiated measurement.

The bandwidth below 30MHz setting on the field strength meter is 9kHz and above 30MHz is 120kHz.

4.5. Uncertainty

Radiated is ± 2.6 dB

4.6. Test Result of Band Edge

Product : TABLET PC
 Test Item : Band Edge Data
 Test Site : No.3 OATS
 Test Mode : Mode 1: Transmit mode

RF Radiated Measurement

(Horizontal)

Frequency (MHz)	Correct Factor (dB)	Reading Level (dBμV)	Emission Level (dBμV/m)	QP Limit (dBμV/m)	Result
13.110	20.430	26.260	46.690	69.540	Pass
13.360	20.420	27.140	47.560	69.540	Pass
13.410	20.420	27.030	47.450	69.540	Pass
14.010	20.400	26.960	47.360	69.540	Pass

Note:

1. All Readings below 1GHz are Quasi-Peak, above are average value.
2. “█” means the worst emission level.
3. Measurement Level = Reading Level + Correct Factor

(Vertical)

Frequency (MHz)	Correct Factor (dB)	Reading Level (dBμV)	Emission Level (dBμV/m)	QP Limit (dBμV/m)	Result
13.110	20.430	24.230	44.660	69.540	Pass
13.360	20.420	23.690	44.110	69.540	Pass
13.410	20.420	24.520	44.940	69.540	Pass
14.010	20.400	26.300	46.700	69.540	Pass

Note:

1. All Readings below 1GHz are Quasi-Peak, above are average value.
2. “█” means the worst emission level.
3. Measurement Level = Reading Level + Correct Factor

5. Frequency Tolerance

5.1. Test Equipment

	Equipment	Manufacturer	Model No./Serial No.	Last Cal.
	Spectrum Analyzer	R&S	FSP40 / 100170	Jun., 2014
	Spectrum Analyzer	Agilent	E4407B / US39440758	Jun., 2014
X	Spectrum Analyzer	Agilent	N9010A / MY48030495	Apr., 2014
X	Temperature Chamber	TDE	CHM 150CT	March, 2014

Note: All equipments are calibrated every one year.

5.2. Test Setup

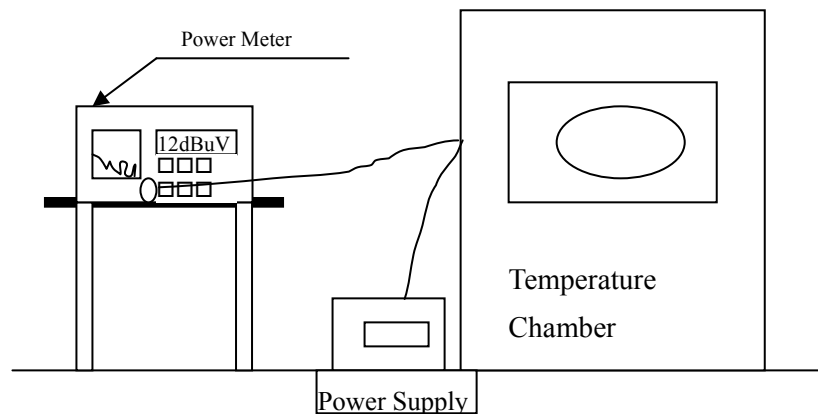

5.3. Limits

The frequency tolerance of the carrier signal shall be maintained within $\pm 0.01\%$ of the operating frequency.

5.4. Test Procedure

The over operating frequency over a temperature variation of -20 degrees to +50 degrees C at normal supply voltage, and for a variation in the primary supply voltage from 85% to 115% of the rated supply voltage at a temperature of 20 degrees C. For battery operated equipment, the equipment tests shall be performed using a new battery.

5.5. Uncertainty

± 150 Hz

5.6. Test Result of Frequency Stability

Product : TABLET PC
 Test Item : Frequency Tolerance
 Test Site : Temperature Chamber
 Test Mode : Mode 1: Transmit mode

Temperature (°C)	Voltage (V)	Observe Time	Declared Frequency (MHz)	Read Frequency (MHz)	Tolerance (%)	Limit (%)
20	120	start	13.56	13.56075	0.005531	± 0.01 %
		2mins	13.56	13.56075	0.005531	
		5mins	13.56	13.56075	0.005531	
		10mins	13.56	13.56075	0.005531	
20	138	start	13.56	13.56075	0.005531	± 0.01 %
		2mins	13.56	13.56075	0.005531	
		5mins	13.56	13.56075	0.005531	
		10mins	13.56	13.56075	0.005531	
20	102	start	13.56	13.56075	0.005531	± 0.01 %
		2mins	13.56	13.56075	0.005531	
		5mins	13.56	13.56075	0.005531	
		10mins	13.56	13.56075	0.005531	
50	120	start	13.56	13.56031	0.002286	± 0.01 %
		2mins	13.56	13.56031	0.002286	
		5mins	13.56	13.56031	0.002286	
		10mins	13.56	13.56031	0.002286	
40	120	start	13.56	13.56047	0.003466	± 0.01 %
		2mins	13.56	13.56047	0.003466	
		5mins	13.56	13.56047	0.003466	
		10mins	13.56	13.56047	0.003466	
30	120	start	13.56	13.56022	0.001622	± 0.01 %
		2mins	13.56	13.56022	0.001622	
		5mins	13.56	13.56022	0.001622	
		10mins	13.56	13.56022	0.001622	

10	120	start	13.56	13.56004	0.000295	± 0.01 %
		2mins	13.56	13.56004	0.000295	
		5mins	13.56	13.56004	0.000295	
		10mins	13.56	13.56004	0.000295	
0	120	start	13.56	13.56004	0.000295	± 0.01 %
		2mins	13.56	13.56004	0.000295	
		5mins	13.56	13.56004	0.000295	
		10mins	13.56	13.56004	0.000295	
-10	120	start	13.56	13.56092	0.006785	± 0.01 %
		2mins	13.56	13.56092	0.006785	
		5mins	13.56	13.56092	0.006785	
		10mins	13.56	13.56092	0.006785	
-20	120	start	13.56	13.56092	0.006785	± 0.01 %
		2mins	13.56	13.56092	0.006785	
		5mins	13.56	13.56092	0.006785	
		10mins	13.56	13.56092	0.006785	

6. EMI Reduction Method During Compliance Testing

No modification was made during testing.

Attachment 1: EUT Test Photographs

Attachment 2: EUT Detailed Photographs